



TRANSLATOR'S CERTIFICATE OF TRANSLATION

Questel-Orbit, Incorporated
2331 Mill Road, Suite 600
Alexandria, VA 22314, U.S.A.
www.questel.com

Questel Project Number: LVMG2440030DE-L_Q (340034-742-018)
Date: November 5, 2024

To whom it may concern:

I, Andrew Levine, a translator fluent in the French and English languages, on behalf of Questel, do solemnly and sincerely declare that the following is, to the best of my knowledge and belief, a true and correct translation of the document(s) listed below in a form that best reflects the intention and meaning of the original text.

I hereby declare that all statements made herein of my own knowledge are true and that all statements made on information and belief are believed to be true. I further declare that these statements were made with the knowledge that willful false statements and the like so made are punishable by fine or imprisonment, or both, under Section 1001 of Title 18 of the United States Code.

Original Document Identifier:	Exhibit A-WO2014091098A1.pdf
Translated Document Identifier:	Exhibit B-English Translation of WO2014091098A1-with Cover
Page & Fig. 1.pdf	

Signed this 5th day of November, 2024



Signature

ANDREW LEVINE

Name

(12) INTERNATIONAL APPLICATION PUBLISHED UNDER THE PATENT COOPERATION TREATY (PCT)

(19) World Intellectual Property Organization
International Bureau

(43) International Publication Date
June 19, 2014 (06.19.2014)



(10) International Publication Number
WO 2014/091098 A1

(51) International Patent Classification:

C01B 3/48 (2006.01)C01B 3/56 (2006.01)

(21) International Application Number:

PCT/EN2013/052613

(22) International Filing Date:

October 31, 2013 (10.31.2013)

(25) Filing Language:

French

(26) Publication Language:

French

(30) Priority Data:

1262002 December 13, 2012 (12.13.2012) FR

(71) Applicant: L'AIR LIQUIDE, SOCIÉTÉ ANONYME POUR L'ÉTUDE ET L'EXPLOITATION DES PROCÉDÉS GEORGES CLAUDE [FR/FR]; 75, Quai d'Orsay, F-75007 Paris (FR).

(72) Inventors: DARDE, Arthur; 32 boulevard Saint-Marcel, F-75005 Paris (FR). LECLERC, Mathieu; 7 rue des Orteaux, F-75020 Paris (FR). MOREL, Thomas; 58 rue Pierre Curie, F-94360 Bry sur Marne (FR).

(74) Agent: CONAN, Philippe; L'air Liquide S.A., 75, Quai d'Orsay, F-75007 Paris (FR).

(81) Designated States (unless otherwise indicated, for every kind of national protection available): AE, AG, AL, AM,

AO, AT, AU, AZ, BA, BB, BG, BH, BN, BR, BW, BY, BZ, CA, CH, CL, CN, CO, CR, CU, CZ, DE, DK, DM, DO, DZ, EC, EE, EG, ES, FI, GB, GD, GE, GH, GM, GT, HN, HR, HU, ID, IL, IN, IR, IS, JP, KE, KG, KN, KP, KR, KZ, LA, LC, LK, LR, LS, LT, LU, LY, MA, MD, ME, MG, MK, MN, MW, MX, MY, MZ, NA, NG, NI, NO, NZ, OM, PA, PE, PG, PH, PL, PT, QA, RO, RS, RU, RW, SA, SC, SD, SE, SG, SK, SL, SM, ST, SV, SY, TH, TJ, TM, TN, TR, TT, TZ, UA, UG, US, UZ, VC, VN, ZA, ZM, ZW.

(84) Designated States (unless otherwise indicated, for every kind of regional protection available): ARIPO (BW, GH, GM, KE, LR, LS, MW, MZ, NA, RW, SD, SL, SZ, TZ, UG, ZM, ZW), Eurasian (AM, AZ, BY, KG, KZ, RU, TJ, TM), European (AL, AT, BE, BG, CH, CY, CZ, DE, DK, EE, ES, FI, FR, GB, GR, HR, HU, IE, IS, FF, LT, LU, LV, MC, MK, MT, NL, NO, PL, PT, RO, RS, SE, SI, SK, SM, TR), OAPI (BF, BJ, CF, CG, CI, CM, GA, GN, GQ, GW, KM, ML, MR, NE, SN, TD, TG).

Declarations under Rule 4.17:

— of inventorship (Rule 4.17.iv)

Published:

— with international search report (Art. 21(3))

(54) Title [English]: PROCESS FOR PRODUCING HYDROGEN BY REFORMING HYDROCARBONS USING STEAM, COMBINED WITH CARBON DIOXIDE CAPTURE AND STEAM PRODUCTION

(54) Title [French]: PROCÉDÉ POUR UNE PRODUCTION D'HYDROGÈNE PAR REFORMAGE D'HYDROCARBURES UTILISANT DE LA VAPEUR, ASSOCIÉ À UNE CAPTURE DE DIOXYDE DE CARBONE ET À UNE PRODUCTION DE VAPEUR

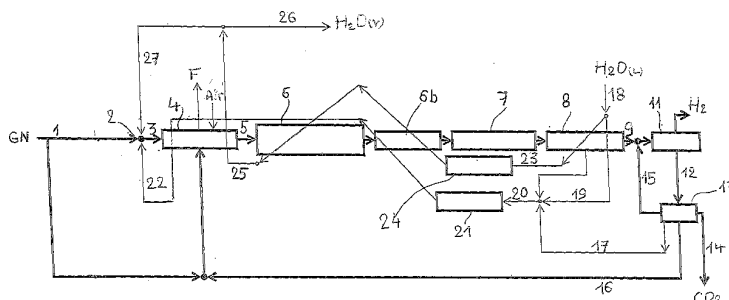

(57) Abstract [English]: The present invention concerns a process for producing hydrogen by reforming hydrocarbons using steam, combined with carbon dioxide capture and steam production, which involves mixing the hydrocarbons to be reformed with steam in order to produce the feedstock for the reforming, generating a synthesis gas (essentially H₂, CO, but also CO₂, excess steam, residual CH₄ and impurities); the synthesis gas produced is cooled, and enriched with H₂ and CO₂ by converting CO with steam; the enriched synthesis gas is cooled, the process condensates are separated from the synthesis gas in order to be used in the process, the saturated synthesis gas being treated by pressure swing adsorption so as to produce hydrogen and an off gas containing CO₂ that is captured in a CO₂-purifying CPU unit. The condensates from the cooling of the synthesis gas at the outlet of the shift reactor are used in the process for producing impure steam supplying the mixing point; the CPU unit also produces CPU condensates that are recycled to be treated jointly with the process condensates.

(57) Abstract [French]:

[Continued on next page]

WO 2014/091098 A1



La présente invention concerne un procédé de production d'hydrogène par reformage d'hydrocarbures utilisant de la vapeur, associé à une capture de dioxyde de carbone et à une production de vapeur, dans lequel on réalise un mélange des hydrocarbures à reformer avec de la vapeur pour produire la charge d'alimentation du reformage, on génère un gaz de synthèse (essentiellement H₂, CO, mais aussi CO₂, vapeur en excès, CH₄ résiduel et des impuretés); le gaz de synthèse produit est refroidi, enrichi en H₂ et CO₂ par conversion du CO à la vapeur; le gaz de synthèse enrichi est refroidi, les condensats de procédé sont séparés du gaz de synthèse pour être utilisés dans le procédé, le gaz de synthèse saturé étant traité par adsorption à modulation de pression pour produire de l'hydrogène et un résiduaire gazeux contenant du CO₂ qui est capturé dans une unité CPU de purification de CO₂. Les condensats issus du refroidissement du gaz de synthèse en sortie de réacteur de shift sont utilisés dans le procédé pour produire de la vapeur impure alimentant le point de mélange; l'unité CPU produit aussi des condensats de CPU qui sont recyclés pour être traités conjointement avec les condensats de procédé.

Process for producing hydrogen by reforming hydrocarbons using steam, combined with carbon dioxide capture and steam production

[0001] The present invention relates to hydrogen production with CO₂ capture.

5 [0002] More specifically, it relates to a process for producing hydrogen by reforming hydrocarbons using steam, combined with carbon dioxide capture and steam production, in particular steam reforming and also autothermal reforming, in which the hydrocarbons to be reformed are mixed with steam so as to produce the feedstock for the reforming, a synthesis gas is generated, comprising essentially hydrogen, carbon monoxide, carbon dioxide, and
10 also excess steam, residual methane, water and impurities; the synthesis gas produced is cooled, enriched with H₂ and CO₂ by converting CO with steam (shift reaction); the enriched synthesis gas is cooled by indirect heat exchange with fluids from the process so as to produce a synthesis gas saturated with water and process condensates which are separated from the synthesis gas so as to be used in the process, the saturated synthesis gas being treated by
15 pressure swing adsorption so as to produce hydrogen and an offgas containing CO₂ which is captured in a CO₂-purification unit.

[0003] The process condensates – that is the condensates resulting from the cooling of the synthesis gas at the outlet of the shift reactor - can be used in the process itself according to two modes.

- 20 • The first mode of use employs a condensate stripper; the process condensates are treated by steam stripping in a column called a stripper, the steam loaded with impurities resulting therefrom being recycled with supplementary highly pure steam at the mixing point for the hydrocarbons with the steam, while the purified condensates are used to produce highly pure steam via the process waste heat boiler both in order to provide the supplementary
25 steam for the mixing point and to provide pure export steam.
- The second mode of use of the condensates does not call for steam stripping of the condensates; the process condensates are mixed with demineralized water as make-up, then are vaporized and then superheated in the waste heat boiler thus generating impure steam for feeding the mixing point with process steam;
- 30 – according to a first variant, in which it is desired to produce highly pure export steam, said steam is treated in a circuit — distinct from the circuit for production of impure steam - where demineralized water is vaporized, then the steam is heated, or superheated if appropriate, by heat exchange with hot fluids from the process (or associated with the process). Some of it is sent as a steam supplement to the mixing
35 point and some of it is exported;
- according to a second variant, implemented in the case where the export steam may be impure steam, the process condensates are mixed with all the demineralized

water, jointly vaporized in the waste heat boiler, the steam being heated, or superheated if appropriate, by heat exchange with hot fluids from the process (or associated with the process); some of the impure steam generated is sent to the mixing point, the excess steam is exported.

5

[0004] The term "highly pure steam" as used in the description and in the claims means steam containing less than 50 ppmv of oxygen, 50 ppmv of carbon dioxide, 50 ppmv of methanol, 50 ppmv of amines and 50 ppmv of ammonia.

10 [0005] The term "process condensates" as used in the description and in the claims means the condensates made up of the aqueous phase obtained from the synthesis gas, during final cooling thereof at the end of the conversion (shift) step, and recovered by separation.

[0006] The invention applies in the context of steam reforming processes, in particular processes for steam methane reforming (SMR) by means of a reforming catalyst, and also in 15 the case of processes that combine steam reforming and partial oxidation of hydrocarbons (autothermal reforming, or ATR, process). In this case, the hydrocarbons are mixed with steam, and then they are partially oxidized in a burner, thus producing the heat required for the reforming reaction at the same time as a hydrogen-depleted gas; this first gas produced is then steam-reformed so as to provide more hydrogen and carbon monoxide. In both these 20 cases, the steam reforming is carried out by means of a reforming catalyst.

[0007] The above steam reforming processes are used to produce synthesis gases from hydrocarbon-based gas feedstocks, the main reaction being the steam methane reforming reaction; in the case of feedstocks comprising hydrocarbons containing at least two carbon atoms, the reforming is preceded by a pre-reforming, which is itself also with steam, the 25 essential function of which is to convert the hydrocarbons containing at least two carbon atoms into carbon monoxide, hydrogen and methane. The obtaining of synthesis gas (also called syngas) generally represents a first step in a final production which may be a production of hydrogen, of CO or of a H₂/CO mixture. Depending on the feedstock to be reformed, on the desired final production and on the operating conditions applied to this effect, the synthesis 30 gases can have different compositions, but are always in the form of a mixture containing mainly hydrogen (H₂) and carbon monoxide (CO) and in smaller proportions carbon dioxide (CO₂), but also unreacted methane (CH₄), excess steam and traces of various compounds, impurities initially present but also generated during the reforming, and essentially due to the presence of the catalyst.

35 [0008] For a final production of essentially hydrogen, the synthesis gas produced is then treated in at least one reactor where the CO conversion reaction takes place, termed "shift reactor", in which the carbon monoxide produced during the reforming is, under the action of

steam present in the synthesis gas and in the presence of an appropriate catalyst, essentially converted into additional hydrogen and carbon dioxide.

[0009] An essential aspect of hydrogen production units is that they exhibit extensive energy integration allowing the use of the heat available in the hot fluids of the unit, in particular for producing steam, preheating reagents or preheating air.

[0010] Indeed, exiting the reformer at a very high temperature between 800 and 950°C, the synthesis gas must be cooled in order to be subsequently converted. It thus undergoes a first cooling to a temperature below 400°C, before being able to enter a shift reactor; the synthesis gas at the shift reactor outlet (or of the final shift reactor) again undergoes cooling to a temperature of between 20 and 60°C, suitable for the downstream treatment by adsorption and the steam present is partially condensed. The saturated synthesis gas is separated from the liquid phase resulting from the condensation which constitutes the “process condensates”.

[0011] These process condensates which contain essentially water are recovered and reused to produce steam by means of the heat originating from the process. All or part of the steam thus produced, termed process steam, is mixed with the feedstock intended for producing the synthesis gas in the reformer. However, the process condensates also contain impurities dissolved in the water; some of these dissolved impurities were present in the streams feeding the reformer, others were produced during the reforming; they originate, however, predominantly from reactions in the shift reactor, and can be attributed to the presence of the catalyst. Among the impurities present in the process condensates, are thus carbon dioxide, methanol, aqueous ammonia and amines.

[0012] As indicated above, depending on the level of impurities in the process condensates and on the quality specifications that the steam intended for exportation must adhere to, several modes of use of these impure process condensates are possible.

[0013] The invention relates more particularly to the processes according to which the process condensates are not purified before vaporization. Thus, they are only deaerated, pumped, preheated, vaporized and then sent at least partially to the mixing point.

[0014] A second aspect — itself also essential — relating to the hydrogen production facilities concerns the capture of the CO₂ produced by these facilities. Indeed, while, in previous decades, the carbon dioxide was simply separated from the hydrogen and generally sent into the atmosphere, the demonstration of global warming and of the role that it plays therein has led

[0015] to ensuring that the CO₂ jointly produced with the hydrogen is captured.

[0016] An industrial-scale hydrogen production facility represents an important source of CO₂ emissions, and improving both the design and the operation thereof for the purpose of reducing CO₂ emissions of human origin in the atmosphere has thus become essential for hydrogen producers. Consequently, processes and technologies have been developed for

capturing carbon dioxide in order both to reduce CO₂ emissions and to improve hydrogen production facilities, in terms of cost and of performance.

[0017] The carbon dioxide emissions of hydrogen production facilities can be reduced using several different separation techniques in order to extract the CO₂ contained in the flue gases, the syngas or the residual gases resulting from the process. The CO₂ thus captured can subsequently be compressed, transported and sequestered in underground storage reservoirs, used for enhanced oil recovery or for industrial or consumption purposes.

[0018] The techniques developed for carbon dioxide capture use essentially cryogenic, membrane, or physical and/or chemical adsorption or absorption processes; the choice of the technology depends in particular on the composition of the gas subjected to the capture, as well as on the costs of the electricity and the steam, on the investment costs and on the (carbon) taxes applied.

[0019] Hydrogen is widely used industrially and in particular by the oil and refining industry for various processes. During steam reforming, the hydrocarbon feedstock is a gaseous feedstock, generally natural gas or a mixture of light hydrocarbons, the main constituent of which is methane. In the remainder of the description, in the interests of simplicity, the example of natural gas (NG) will be mentioned. The feedstock generally undergoes a pretreatment intended to remove the sulphides present so as to not poison the catalysts that will be used during the reforming. The strongly endothermic reforming reaction takes place at high temperature and at high pressure (800 to 950°C and 13.5 to 55 bar (a)). The heat required for the methane reforming reaction is supplied:

- in the case of steam methane reforming (SMR), by the combustion of combustible gas - feed natural gas and residual gas from the process (generally derived from a PSA residual gas) essentially — with air in the combustion zone thus producing flue gases at very high temperature;
- in the case of autothermal reforming (ATR) by partial oxidation of the feedstock - in this case, the PSA residual gas is conventionally burnt to produce steam in a dedicated boiler.

[0020] The syngas resulting from the reforming is itself also very hot, and a part of the available heat is used to heat up water from the waste heat boiler in order to produce steam.

[0021] The syngas cooled a first time can be sent to a reactor so as to produce additional hydrogen from the conversion of CO to CO₂ in the presence of water. This reactor is termed a “shift reactor” (also known as WGS reactor, WGS being the abbreviation for water gas shift). Following this step of the process, the CO₂ content of the syngas downstream of the WGS reactor increases, together with its H₂ content.

[0022] The syngas enriched with H₂ and CO₂ (and CO-depleted) is usually treated by pressure swing adsorption in an H₂ PSA unit so as to produce a gaseous stream of substantially pure hydrogen.

[0023] At the same time as the almost pure hydrogen, the H₂ PSA unit produces a PSA offgas which contains the CO₂ contained in the synthesis gas feeding the PSA unit, and also the methane which did not react during the reforming, CO which did not react during the conversion step, and a part of the hydrogen feeding the PSA unit. Because of the presence
5 of gases with high calorific values (methane, carbon monoxide and hydrogen), the PSA offgas is usually sent as fuel to the burners of the SMR or of the dedicated boiler in the case of an ATR.

[0024] The PSA offgas is the gaseous stream richest in CO₂ of the process described above (typically 40-55% in the absence of capture upstream); the offgas is available at a pressure
10 below 2 bar(a). By virtue of this relatively high CO₂ content, the cryogenic CO₂ capture solution may be applied to the PSA offgas.

[0025] Cryogenic CO₂ capture (CPU) calls for the partial condensation and/or the distillation of the CO₂ contained in the CO₂-rich gaseous stream in a cryogenic purification unit (CPU). It should be noted that, since the partial condensation is carried out under pressure, the literature
15 also makes reference to the purification/compression duality as a replacement for the purification/cryogenics duality for the same abbreviation CPU, and the same operation. The gas, after drying and compression to a pressure between 20 and 100 bar(a), is cooled to a temperature close to that of the triple point of CO₂ (approximately -56°C). Under these temperature and pressure conditions, it will partially condense, the liquid phase being
20 particularly enriched with CO₂ and the gas phase with non-condensable gases. The liquid obtained can then be distilled so as to achieve CO₂ purities greater than 99%.

[0026] A process of CO₂ capture by CPU —applied to the PSA offgas — operates according to the following scheme:

[0027] the gaseous stream of offgas is compressed and dried such that its pressure is
25 between approximately 20 and 100 bar(a), then it undergoes one or more successive condensation/separation steps in the CPU unit so as to produce a liquid stream enriched with CO₂ and a gaseous stream (capture offgas) enriched with hydrogen and with other constituents lighter than CO₂ and therefore non-condensable under the operating conditions, in particular CH₄, H₂ and CO. The condensation/separation steps can be supplemented by
30 membrane separation steps.

[0028] During the compression step preceding the drying step, the water contained in the offgas will partially condense with a part of the water-soluble impurities contained in the gas. The pressure during the drying step is between 1 and 50 bar(a), the pressure of the condensates formed is consequently between approximately 1 and 50 bar(a). Formed in the
35 CPU unit, they are denoted "CPU condensates" in the description and in the claims. The CPU condensates are separated prior to the separation/condensation of the CO₂ and are discharged as wastewater to a treatment plant which may be a wastewater treatment plant of

the industrial site where the CPU is installed, but will more commonly be a dedicated treatment plant; in the absence of a wastewater treatment plant available for treating these additional condensates, or if the plant already present is not capable of treating the CPU condensates owing to their. In particular, the presence of methanol in the CPU condensates is very
5 bothersome, since it is a powerful bactericide which limits or even makes impossible a treatment by bacterial degradation commonly used for waste water treatment. A facility for treatment of condensates of this type is relatively expensive since it is difficult to implement, more particularly owing to the presence of methanol in the condensates.

[0029] It is therefore desirable to use a technique for treating these condensates which is
10 more economical and especially less sensitive to methanol content. The solution according to the invention consists in integrating the treatment of the condensates coming from the CPU into the hydrogen production process; more specifically, it will involve, according to the invention, combining the treatment of the CPU condensates with that of the process condensates resulting from the cooling of the synthesis gas as described above.

[0030] This solution, integrated into the process, also has advantageous adaptations and variants according to the situations; namely:

- the total number of pieces of condensate treatment equipment is not increased — no equipment for treatment of the CPU condensates before discharge — the investment costs are therefore reduced, as is the ground occupancy of the facility;
- since the condensates of the CPU are recycled to the reforming zone, the make-up of demineralized water required by the hydrogen production unit is decreased accordingly;
- the compounds present in the condensates and which can be incorporated into the feedstock are sent with the steam to the reforming. They are then eliminated and participate in hydrogen production.

[0031] To achieve this, the main subject matter of the invention is a process for producing
25 hydrogen by reforming hydrocarbons using steam, combined with carbon dioxide capture and steam production, comprising at least the steps of

a) mixing the hydrocarbons to be reformed with steam so as to produce the feedstock for the reforming,

30 b) generating, by reforming, a synthesis gas comprising essentially hydrogen, carbon monoxide and also excess steam, carbon dioxide, residual methane, water and impurities from the mixture resulting from step a),

c) first cooling of the synthesis gas,

d) generating a synthesis gas enriched with H₂ and CO₂ by steam conversion of the CO
35 contained in the cooled synthesis gas resulting from step c),

e) cooling the synthesis gas enriched with H₂ and CO₂ resulting from step d) by indirect heat exchange to a temperature of about ambient temperature, at least below 60°C and

preferably below or equal to 40°C, so as to produce a saturated synthesis gas and condensates C1,

f) separating the condensates C1 from the saturated synthesis gas resulting from e),

g) treating the synthesis gas resulting directly or indirectly from step f) in a unit for hydrogen purification by pressure swing adsorption, so as to produce a stream of hydrogen having a purity of at least 99% and a stream of offgas containing at least 40% of CO₂,

h) treating the stream of PSA offgas resulting from step g) in a CPU unit producing at least one stream of purified CO₂ and at least one stream of non-condensables,

and also steps of treating all or part of the condensates C1 resulting from the process, alone or as a mixture with make-up demineralized water, comprising at least the steps of:

kl) reducing the pressure of the condensates C1 to a pressure of between 1 and 5 bar(a), preferably between 1 and 2 bar(a),

k2) passing the reduced-pressure condensates C1 through a deaerator in order to eliminate a part of the gases dissolved in the condensates C1,

k3) pumping the condensates C1 at a pressure of between 15 and 90 bar(a), preferably between 25 and 70 bar(a),

k4) preheating the condensates C1 under pressure to a temperature of between 150 and 290°C, preferably between 200 and 280°C,

k5) vaporizing the condensates C1 under pressure at a temperature of between 200 and 300°C, preferably between 220 and 290°C, so as to produce a stream of impure steam,

k6) recycling the impure steam to step a) so as to be mixed with the hydrocarbons to be reformed,

and also steps of producing steam intended for export, comprising at least the steps of:

vl) feeding a steam circuit associated with the process with demineralized water alone or mixed with the condensates C1,

v2) preheating the water,

v3) vaporizing the preheated water against the synthesis gas originating from the reforming in a waste heat boiler so as to produce a stream of steam,

v4) recycling a part of the steam to step a) so as to be mixed with the hydrocarbons to be reformed,

v5) making the remaining steam available for export,

characterized in that the treatment step h) also produces at least one stream of condensates C2, and the condensates C2 are recovered and recycled into the process upstream of step k5) of vaporizing the condensates C1.

[0032] In this way, the residual impurities present in the condensates C2 of the CPU are

mixed in the steam with those of the process condensates C1, and are recovered as reforming feedstock.

[0033] In accordance with other advantageous characteristics of the invention, the latter may exhibit one or more of the variants which are described hereinafter.

5 [0034] According to their pressure and their temperature, the condensates C2 from the CPU are added to the process condensates C1 upstream of the vaporizing of the condensates, in various locations, after having undergone, if required, heating and/or pumping and/or deaeration steps, via the means for pumping, heating or deaerating the process condensates C1 or via dedicated means. Indeed, the pressure of the condensates C2 depends on the
10 pressure of the gas treated by the CPU. Thus, advantageously:

- the condensates C2 can be mixed with the condensates C1 upstream of the deaerator; this variant is preferably used when the condensates C2 originating from the CPU unit are at a pressure above or equal to that of the condensates C1 before the pumping of said condensates C1, but below the operating pressure of the exchanger for preheating or
15 vaporizing; when the condensates C2 are at a temperature sufficient for correct operation of the unit; when the deaerator, the pump for the condensates C1 and the exchanger for preheating the condensates C1 are able to treat the additional flow of condensates C2 and when it proves necessary to deaerate the condensates C2;
- the condensates C2 can be pumped at the pressure of the condensates C1 after reduction
20 of the pressure of said condensates C1 and mixed with the condensates C1 upstream of the deaerator; this variant is preferably used when the condensates C2 originating from the CPU unit are at a pressure below that of the condensates C1 before pumping of said condensates; when the condensates C2 are at a temperature sufficient for correct operating of the unit; when the deaerator, the pump for the condensates C1 and the
25 exchanger for preheating the condensates C1 are able to treat the additional flow of condensates C2 and when it proves necessary to deaerate the condensates C2;
- the condensates C2 can be preheated and mixed with the condensates C1 upstream of the deaerator; this variant is preferably used when the condensates C2 originating from the CPU unit are at a pressure above or equal to that of the condensates C1 before the
30 pumping of said condensates C1, but below the operating pressure of the exchanger for preheating or vaporizing; when the deaerator, the pump for the condensates C1 and the exchanger for preheating the condensates C1 are able to treat the additional flow of condensates C2; when it proves necessary to deaerate the condensates C2; but when the temperature of the condensates C2 is too low to ensure correct operation of the unit;
- the condensates C2 can be pumped, preheated at the pressure of the condensates C1 after reduction of the pressure of said condensates C1 and mixed with the condensates
35 C1 upstream of the deaerator; this variant is preferably used when the condensates C2

- originating from the CPU unit are at a pressure below that of the condensates C1 before the pumping of said condensates; when the deaerator, the pump for the condensates C1, and the exchanger for preheating the condensates C1 are able to treat the additional flow of condensates C2; when it proves necessary to deaerate the condensates C2; but when
- 5 the temperature of the condensates C2 is too low to ensure correct functioning of the unit;
- the condensates C2 can be mixed with the condensates C1 downstream of the deaerator; this variant is preferably used when the condensates C2 originating from the CPU unit are at a pressure above or equal to that of the condensates C1 before the pumping of said condensates C1, but below the operating pressure of the exchanger for preheating or
- 10 vaporizing; when the pump for the condensates C1 and the exchanger for preheating the condensates C1 are able to treat the additional flow of condensates C2 and when it does not prove necessary to deaerate the condensates C2;
- the condensates C2 can be pumped and mixed with the condensates C1 downstream of the deaerator; this variant is preferably used when the condensates C2 originating from
- 15 the CPU unit are at a pressure below that of the condensates C1 before the pumping of said condensates C1; when the pump for the condensates C1 and the exchanger for preheating the condensates C1 are able to treat the additional flow of condensates C2 and when it does not prove necessary to deaerate the condensates C2;
 - the condensates C2 can be mixed with the condensates C1 downstream of the pump for the condensates C1; this variant is preferably used when the condensates C2 originating

20 from the CPU unit are at a pressure above or equal to that of the condensates C1 after the pumping of said condensates C1; when the exchanger for preheating the condensates C1 is able to treat the additional flow of condensates C2 and when it does not prove necessary to deaerate the condensates C2;
 - the condensates C2 can be pumped and mixed with the condensates C1 downstream of the pump for the condensates C1; this variant is preferably used when the condensates

25 C2 originating from the CPU unit are at a pressure below that of the condensates C1 after the pumping of said condensates C1; when the exchanger for preheating the condensates C1 is able to treat the additional flow of condensates C2 and when it does not prove

30 necessary to deaerate the condensates C2;
 - the condensates C2 can be mixed with the condensates C1 downstream of the exchanger for preheating the condensates C1; when this variant is preferably used when the condensates C2 originating from the CPU unit are at a pressure above or equal to that of

35 the condensates C1 after the pumping of said condensates; when the condensates C2 are at a temperature sufficient for correct operation of the unit and it does not prove necessary to deaerate the condensates C2;
 - the condensates C2 can be pumped and mixed with the condensates C1 downstream of

the exchanger for preheating the condensates C1; this variant is preferably used when the condensates C2 originating from the CPU unit are at a pressure below that of the condensates C1 after the pumping of said condensates C1; when the condensates C2 are at a temperature sufficient for correct functioning of the unit and when it does not prove necessary to deaerate the condensates C2;

- the condensates C2 can be preheated and mixed with the condensates C1 downstream of the exchanger for preheating the condensates C1; this variant is preferably used when the condensates C2 originating from the CPU unit are at a pressure above or equal to that of the condensates C1 after the pumping of said condensates C1; when the condensates C2 are not at a temperature sufficient for correct operation of the unit and when it does not prove necessary to deaerate the condensates C2;
- the condensates C2 can be pumped, preheated and mixed with the condensates C1 downstream of the exchanger for preheating the condensates C1; this variant is preferably used when the condensates C2 originating from the CPU unit are at a pressure below that of the condensates C1 after the pumping of said condensates C1; when the condensates C2 are not at a temperature sufficient for correct operation of the unit and when it does not prove necessary to deaerate the condensates C2.

[0035] According to one advantageous variant of the process, when a column for washing with water - operating at a pressure of between 1 and 100 bar(a) - is used to wash the PSA offgas stream, it will be possible to recover the impurity-loaded liquid at the bottom of this column and to recycle it, with the condensates C2 of the CPU, into the circuit for vaporizing the condensates C1. This step of washing the PSA offgas with water is added in particular when a large reduction in methanol and in ammonia is desirable in the CPU.

[0036] If the export steam is required to have high purity, the demineralized water is not mixed entirely with the condensates C1 and C2, and the export steam is entirely produced from demineralized water in a dedicated circuit, while at least one part of the steam intended for the mixing point is produced in a circuit distinct from the highly pure steam circuit, from the condensates C1 and C2.

[0037] If it is sufficient for the export steam to have low purity, all of the demineralized water is mixed with the condensates C1 and C2, such that the export steam, like the steam intended for the mixing point, is produced from the mixture of the condensates C1, the condensates C2 and the demineralized water.

[0038] According to another aspect of this invention, the latter relates to a facility for producing hydrogen by reforming hydrocarbons using steam, combined with carbon dioxide capture and steam production, comprising at least:

(i) means for mixing the hydrocarbons to be reformed with steam so as to produce the feedstock for the reforming,

(ii) a reformer for the reforming of a synthesis gas comprising essentially hydrogen, carbon monoxide and also excess steam, carbon dioxide, residual methane, water and impurities from the mixture resulting from step a),

(iii) at least one heat exchanger for cooling the synthesis gas,

5 (iv) at least one shift reactor for steam conversion of the CO contained in the cooled synthesis gas resulting from the exchanger (iii),

(v) at least one heat exchanger for cooling the synthesis gas enriched with H₂ and CO₂ produced by the shift reactor (iv) by indirect heat exchange to a temperature of about ambient temperature, at least below or equal to 60°C, preferably below or equal to 40°C, so as to
10 produce a saturated synthesis gas and condensates Cl,

(vi) a separator for separating the condensates Cl from the saturated synthesis gas resulting from the exchanger (v),

(vii) a unit for hydrogen purification by pressure swing adsorption for treating the synthesis gas resulting directly or indirectly from step (vi) and producing a stream of hydrogen
15 having a purity of at least 99% and a stream of offgas containing at least 40% of CO₂,

(viii) a CPU unit for treating the PSA offgas stream produced by the PSA unit (vii) and producing at least one stream of purified CO₂ and at least one stream of non-condensables, and also means for treating all or part of the condensates Cl from the separator (vi) and comprising at least

20 (ix) a valve for reducing the pressure of the condensates Cl to a pressure of between 1 and 5 bar(a), preferably between 1 and 2 bar(a),

(x) a deaerator in order to eliminate a part of the gases dissolved in the condensates Cl,

(xi) a pump for pumping the condensates Cl at a pressure of between 15 and 90
25 bar(a), preferably between 25 and 70 bar (a),

(xii) a heat exchanger for preheating the condensates Cl under pressure to a temperature of between 150 and 290°C, preferably between 200 and 280°C,

(xiii) a heat exchanger for vaporizing the condensates Cl under pressure at a temperature of between 200 and 300°C, preferably between 220 and 290°C, so as to
30 produce a stream of impure steam,

(xiv) means for recycling the impure steam to step a) so as to be mixed with the hydrocarbons to be reformed,

and also means for producing steam intended for export, comprising a steam production circuit, and also at least:

35 (xv) means for feeding a circuit of steam associated with the process with demineralized water alone or mixed with the condensates Cl,

(xvi) a heat exchanger for preheating the water,

(xvii) a heat exchanger for vaporizing the preheated water against the synthesis gas originating from the reforming in a waste heat boiler, preferably between 220 and 280°C, so as to produce a stream of steam,

5 (xviii) means for recycling a part of the steam to step a) so as to be mixed with the hydrocarbons to be reformed,

(xix) means for making steam available for export, characterized in that, since the CPU unit also produces at least one stream of condensates C2, the facility also comprises means for recovering and recycling the condensates C2 so as to be treated together with the condensates C1.

10 [0039] Advantageously, the facility for producing hydrogen by reforming hydrocarbons using steam, for capturing carbon dioxide and for producing steam, also comprises means for mixing the condensates C2 with the condensates C1 placed before the deaerator of the condensates C1, and also, if required, a pump for pumping the condensates C2 prior to the mixing thereof with the condensates C1.

15 [0040] According to another variant, the facility for producing hydrogen by reforming hydrocarbons using steam, for capturing carbon dioxide and for producing steam, comprises means for preheating the condensates C2, means for mixing the preheated condensates C2 with the condensates C1 placed before the deaerator of the condensates C1, and also, if required, a pump for pumping the condensates C2 prior to the preheating thereof and the
20 mixing thereof with the condensates C1.

[0041] Other characteristics and advantages of the invention will emerge on reading the description which follows. One embodiment of the invention is represented therein in the single figure, and described hereinafter by way of nonlimiting example.

[0042] The figure thus presents a diagram of a process for producing hydrogen according to
25 the invention with separate productions of steams of distinct qualities in two distinct circuits.

[0043] A stream **1** of natural gas (NG) is sent to the mixing point **2** so as to be mixed there with two streams of steam **22** and **27** produced in the process. The mode of production of these two streams of steam will be described subsequently. The stream **3** resulting from the mixing constitutes the feedstock feeding a steam methane reforming (SMR) module **4**, the gas
30 produced **5** is a synthesis gas comprising essentially hydrogen H₂ and CO, but also CO₂, CH₄, water and impurities; the gas **5** is cooled by heat exchange with water, first in the waste heat boiler **6** where the water is vaporized and then via a cooling module **6b** comprising two heat exchangers in parallel, then feeds the conversion module **7**, thus producing a synthesis gas enriched with H₂ and CO₂ and depleted of CO compared with the gas **5** produced by reforming,
35 and also containing additional impurities generated during the conversion - of about 65% to 85% of H₂, 11% to 22% of CO₂, 0.5% to 6% of unconverted CO and 3% to 10% of CH₄.

[0044] The synthesis gas is then cooled in **8** by heat exchange against water, in particular

against demineralized water **18**, to a temperature below or equal to 60°C, more generally below or equal to 40 °C, allowing partial condensation of the water present in the synthesis gas and also of certain condensable impurities. The saturated synthesis gas **9** is separated from the liquid fraction **10** consisting of the impure process condensates Cl (i.e. loaded with impurities entrained with the water).

[0045] The synthesis gas **9** is then sent at **11** to the H₂ PSA unit which produces at least one gaseous stream of highly pure (greater than 99%) hydrogen, and also a residual gas **12** which for its part contains all the carbon dioxide, the vast majority of the unconverted methane and of the unconverted carbon monoxide, and a large part of the nitrogen and hydrogen, the quality of which depends on the yield from the H₂ PSA.

[0046] The residual gas **12** is sent at **13** to a CPU unit for separation of the CO₂, the CPU unit producing at least one stream **14** of CO₂, a gaseous stream **15** rich in hydrogen H₂ which is recycled so as to feed the H₂ PSA in order to recover the hydrogen contained and to thus improve the overall hydrogen yield of the facility, a stream **16** of non-condensables comprising methane, hydrogen, carbon monoxide, non-condensed carbon dioxide, nitrogen and water, constituting the CPU offgas which is recycled as reforming fuel to the reforming module **4**, and a liquid stream **17** made up of the CPU condensates C2; produced in the CPU unit, at least partly at the compression/drying stage which precedes the first CO₂ condensation step, these CPU condensates (condensates C2) contain predominantly water and also dissolved impurities, for instance methanol, aqueous ammonia and amines. By applying the process of the invention, the condensates C2 are recycled so as to be treated with the process condensates Cl.

[0047] More specifically, the stream **10** of the process condensates Cl, the stream **17** of the CPU condensates C2 and an additional stream of water **19** taken from the external supply of demineralized water **18** and heated by heat exchange with the synthesis gas in the heat exchanger **8** are combined so as to form a stream **20** containing water and the impurities contained in the two streams of condensates Cl and C2. The resulting stream **20** is treated in the deaerator **21** then heated by heat exchange against the synthesis gas in one of the two heat exchangers of the synthesis gas cooling module **6b** and vaporized against the flue gases **F** in the convection zone of the reforming module **4**, thus forming the stream of impure steam **22**. This impure steam containing the impurities contained in the condensates Cl and C2 feeds the mixing point **2**.

[0048] Alongside this circuit for producing dirty steam, the process of the figure makes available highly pure superheated steam for the specific needs of the process and for the production of export steam H₂O(v). This second steam production circuit, distinguished from the impure steam circuit, operates in the following way. The second part **23** of water taken from the external supply of demineralized water **18** is heated against the synthesis gas in the

exchanger **8**, treated in the deaerator **24**, then heated by heat exchange against the synthesis gas in the second heat exchanger of the module **6b**, and vaporized in the boiler **6**, thus forming the stream of steam **25**. This stream of highly pure steam passes through the convection zone of the reformer where it recovers additional heat from the flue gases **F**; it is separated into two parts, one of them constitutes the superheated highly pure export steam **26**, the second forms the stream of steam **27** sent to the mixing point **2**.

CLAIMS

1. A process for producing hydrogen by reforming hydrocarbons using steam, combined with carbon dioxide capture and steam production, comprising at least the steps of

5 a) mixing the hydrocarbons to be reformed with steam so as to produce the feedstock for the reforming,

b) generating, by reforming, a synthesis gas comprising essentially hydrogen, carbon monoxide and also excess steam, carbon dioxide, residual methane, water and impurities from the mixture resulting from step a),

10 c) first cooling of the synthesis gas,

d) generating a synthesis gas enriched with H₂ and CO₂ by steam conversion of the CO contained in the cooled synthesis gas resulting from step c),

e) cooling the synthesis gas enriched with H₂ and CO₂ resulting from step d) by indirect heat exchange to a temperature of about ambient temperature, at least below or equal to 60°C and preferably below or equal to 40°C, so as to produce a saturated synthesis gas and condensates Cl,

f) separating the condensates Cl from the saturated synthesis gas resulting from e),

g) treating the synthesis gas resulting directly or indirectly from step f) in a unit for hydrogen purification by pressure swing adsorption, so as to produce a stream of hydrogen having a purity of at least 99% and a stream of offgas containing at least 40% of CO₂,

h) treating the stream of PSA offgas resulting from step g) in a CPU unit producing at least one stream of purified CO₂ and at least one stream of non-condensables,

and also steps of treating all or part of the condensates Cl resulting from the process, comprising at least the steps of

25 k1) reducing the pressure of the condensates Cl to a pressure of between 1 or 5 bar(a), preferably between 1 and 2 bar(a),

k2) passing the condensates Cl through a deaerator in order to eliminate a part of the gases dissolved in the condensates Cl,

30 k3) pumping the condensates Cl at a pressure of between 15 and 90 bar(a), preferably between 25 and 70 bar(a),

k4) preheating the condensates Cl under pressure at a temperature of between 150 and 290°C, preferably between 200 and 280°C,

k5) vaporizing the condensates Cl under pressure at a temperature of between 200 and 300°C, preferably between 220 and 290°C, so as to produce a stream of impure steam,

35 k6) recycling the impure steam to step a) so as to be mixed with the hydrocarbons to be reformed, and also steps of producing highly pure steam intended for export, comprising at least the steps of:

vi) feeding a steam circuit associated with the process with demineralized water alone or mixed with the condensates C1,

v2) preheating the water,

v3) vaporizing the preheated water against the synthesis gas originating from the reforming in a waste heat boiler so as to produce a stream of steam,

v4) recycling a part of the steam to step a) so as to be mixed with the hydrocarbons to be reformed,

v5) making steam available for export, characterized in that the treatment step h) also produces at least one stream of condensates C2, and the condensates C2 are recovered and recycled into the process upstream of step k5) of vaporizing the condensates C1.

2. The process as claimed in claim 1, wherein the condensates C2 — having been previously pumped if required — are mixed with the condensates C1 before the deaeration of the condensates C1.

3. The process as claimed in claim 1, wherein the condensates C2 — having been previously pumped if required — are preheated and then mixed with the condensates C1 before the deaeration of the condensates C1.

4. The process as claimed in claim 1, wherein the condensates C2 — having been previously pumped if required — are mixed with the condensates C1 after the deaeration but before the pumping of the condensates C1.

5. The process as claimed in claim 1, wherein the condensates C2 — having been previously pumped if required — are mixed with the condensates C1 after the deaeration and the pumping but before the preheating of the condensates C1.

6. The process as claimed in claim 1, wherein the condensates C2 — having been previously pumped if required — are mixed with the condensates C1 after the preheating of the condensates C1.

7. The process as claimed in claim 1, wherein the condensates C2 — having been previously pumped if required — are preheated and then mixed with the condensates C1 after the preheating of the condensates C1.

8. The process as claimed in one of the preceding claims, wherein, since washing with water is carried out on the PSA offgas stream, the impurity-loaded liquid stream produced is recycled into the process upstream of step k5) of vaporizing the condensates C1.

9. The process as claimed in one of claims 1 to 8, wherein only a part of the demineralized water of step v1) is mixed with the condensates C1.

10. The process as claimed in one of claims 1 to 8, wherein all the demineralized water of step vi) is mixed with the condensates C1.

11. A facility for producing hydrogen by reforming hydrocarbons using steam,

combined with carbon dioxide capture and steam production, comprising at least:

(i) means for mixing the hydrocarbons to be reformed with steam so as to produce the feedstock for the reforming,

5 (ii) a reformer for the production of a synthesis gas comprising essentially hydrogen, carbon monoxide and also excess steam, carbon dioxide, residual methane, water and impurities from the mixture resulting from step a),

(iii) at least one heat exchanger for cooling the synthesis gas,

(iv) at least one shift reactor for steam conversion of the CO contained in the cooled synthesis gas resulting from the exchanger (iii),

10 (v) at least one heat exchanger for cooling the synthesis gas enriched with H₂ and CO₂ produced by the shift reactor (iv) by indirect heat exchange to a temperature of about ambient temperature, at least below or equal to 60°C, preferably below or equal to 40°C, so as to produce a saturated synthesis gas and condensates Cl,

(vi) a separator for separating the condensates Cl from the saturated synthesis gas
15 resulting from the exchanger (v),

(vii) a unit for hydrogen purification by pressure swing adsorption for treating the synthesis gas resulting directly or indirectly from step (vi) and producing a stream of hydrogen having a purity of at least 99% and a stream of offgas containing at least 40% of CO₂,

(viii) a CPU unit for treating the PSA offgas stream produced by the PSA unit (vii) and
20 producing at least one stream of purified CO₂ and at least one stream of non-condensables,
and also means for treating all or part of the condensates Cl from the separator (vi)
and comprising at least

(ix) a valve for reducing the pressure of the condensates Cl to a pressure of between 1 and 5 bar (a), preferably between 1 and 2 bar(a),

25 (x) a deaerator in order to eliminate a part of the gases dissolved in the condensates Cl,

(xi) a pump for pumping the condensates Cl at a pressure of between 15 and 90 bar(a), preferably between 25 and 70 bar(a),

30 (xii) a heat exchanger for preheating the condensates Cl under pressure at a temperature of between 150 and 290°C, preferably between 200 and 280°C,

(xiii) a heat exchanger for vaporizing the condensates Cl under pressure at a temperature of between 200 and 300°C, preferably between 220 and 290 °C, so as to produce a stream of impure steam,

(xiv) means for recycling the impure steam to step a) so as to be mixed with the
35 hydrocarbons to be reformed,

and also means for producing steam intended for export, comprising a steam production circuit, and also at least:

(xv) means for feeding a circuit of steam associated with the process with demineralized water alone or mixed with the condensates C1,

(xvi) a heat exchanger for preheating the water,

(xvii) a heat exchanger for vaporizing the preheated water against the synthesis gas
5 originating from the reforming in a waste heat boiler so as to produce a stream of steam,

(xviii) means for recycling a part of the steam to step a) so as to be mixed with the hydrocarbons to be reformed,

(xix) means for making steam available for export, characterized in that, since the CPU unit also produces at least one stream of condensates C2, the facility also comprises means
10 for recovering and recycling the condensates C2 so as to be treated together with condensates C1.

12. The facility as claimed in claim 11 for producing hydrogen by reforming hydrocarbons using steam, capturing carbon dioxide and producing steam comprising means for mixing the condensates C2 with the condensates C1 placed before the deaerator of the
15 condensates C1, and also, if required, a pump for pumping the condensates C2 prior to the mixing thereof with the condensates C1.

13. The facility as claimed in claim 11 for producing hydrogen by reforming hydrocarbons using steam, capturing carbon dioxide and producing steam comprising means for preheating the condensates C2, means for mixing the preheated condensates C2 with the
20 condensates C1 placed before the deaerator of the condensates C1, and also, if required, a pump for pumping the condensates C2 prior to the preheating thereof and the mixing thereof with the condensates C1.

Abstract:

The present invention concerns a process for producing hydrogen by reforming hydrocarbons using steam, combined with carbon dioxide capture and steam production, which involves
5 mixing the hydrocarbons to be reformed with steam in order to produce the feedstock for the reforming, generating a synthesis gas (essentially H₂, CO, but also CO₂, excess steam, residual CH₄ and impurities); the synthesis gas produced is cooled, and enriched with H₂ and CO₂ by converting CO with steam; the enriched synthesis gas is cooled, the process condensates are separated from the synthesis gas in order to be used in the process, the
10 saturated synthesis gas being treated by pressure swing adsorption so as to produce hydrogen and an offgas containing CO₂ that is captured in a CO₂-purifying CPU unit. The condensates from the cooling of the synthesis gas at the outlet of the shift reactor are used in the process for producing impure steam supplying the mixing point; the CPU unit also produces CPU condensates that are recycled to be treated jointly with the process
15 condensates.

