



(12) **United States Patent**
Hirsch

(10) **Patent No.:** **US 9,532,858 B2**
(45) **Date of Patent:** ***Jan. 3, 2017**

- (54) **INTRAORAL DEVICE AND METHOD OF USE**
- (71) Applicant: **Innerlite, Inc.**, Santa Barbara, CA (US)
- (72) Inventor: **James A. Hirsch**, Santa Barbara, CA (US)
- (73) Assignee: **Innerlite, Inc.**, Santa Barbara, CA (US)
- (*) Notice: Subject to any disclaimer, the term of this patent is extended or adjusted under 35 U.S.C. 154(b) by 0 days.
This patent is subject to a terminal disclaimer.

- (56) **References Cited**
- U.S. PATENT DOCUMENTS
- | | | | |
|---------------|---------|----------|---------------------|
| 1,122,086 A | 12/1914 | William | |
| 2,510,125 A | 6/1950 | Meakin | |
| 2,937,445 A * | 5/1960 | Erickson | A61B 1/24
433/93 |
| 3,090,122 A | 5/1963 | Erickson | |
| D210,583 S | 3/1968 | Westlund | |
- (Continued)

- FOREIGN PATENT DOCUMENTS
- | | | |
|----|---------------|--------|
| GB | 1017515 A | 1/1966 |
| WO | 2008064904 A1 | 6/2008 |

- OTHER PUBLICATIONS
- International Search Report and Written Opinion of PCT/US2015/032219, Korean Intellectual Property Office, Sep. 8, 2015, 16 pages.
(Continued)

Primary Examiner — Nicholas Lucchesi
(74) *Attorney, Agent, or Firm* — Procopio Cory Hargreaves and Savitch LLP

- (21) Appl. No.: **15/169,367**
- (22) Filed: **May 31, 2016**
- (65) **Prior Publication Data**
US 2016/0270890 A1 Sep. 22, 2016

- Related U.S. Application Data**
- (63) Continuation of application No. 14/285,248, filed on May 22, 2014, now Pat. No. 9,358,086.
 - (51) **Int. Cl.**
A61C 17/06 (2006.01)
A61C 5/14 (2006.01)
A61B 13/00 (2006.01)
 - (52) **U.S. Cl.**
CPC *A61C 17/043* (2013.01); *A61B 13/00* (2013.01); *A61C 5/14* (2013.01)

- (58) **Field of Classification Search**
CPC A61C 17/043; A61C 17/04; A61C 5/007; A61C 5/14; A61C 17/00; A61C 17/14; A61C 19/00
USPC 433/91, 93, 29, 136, 138, 140
See application file for complete search history.

- (57) **ABSTRACT**
- An intraoral device includes a flexible body having an upper front flap including evacuation holes and an upper edge; an upper rear flap forming an upper pocket with the upper front flap and including internal channels and an upper edge separated from the upper edge of the upper front flap to form an upper pocket opening, the internal channels terminating in grooves along the upper edge; a lower front flap including evacuation holes and a lower edge; a lower rear flap forming a lower pocket with the lower front flap and including internal channels and a lower edge separated from the lower edge of the lower front flap to form a lower pocket opening, the internal channels terminating in grooves along the lower edge.

11 Claims, 10 Drawing Sheets

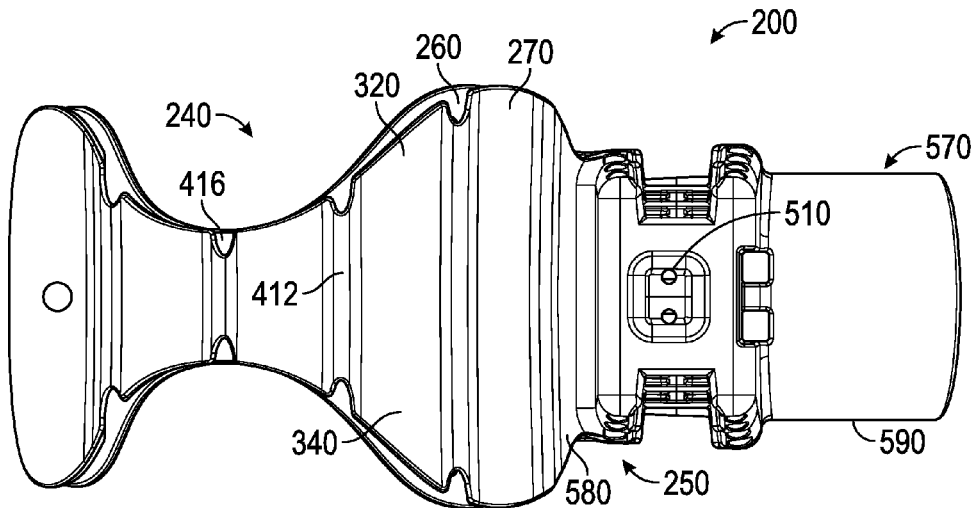

(56)

References Cited

U.S. PATENT DOCUMENTS

3,396,468 A 8/1968 Dayhoff
 3,864,831 A * 2/1975 Drake A61C 17/043
 433/91
 3,881,254 A 5/1975 Epstein et al.
 4,017,975 A 4/1977 Johnson
 4,024,642 A 5/1977 Zorovich
 4,167,814 A 9/1979 Schubert
 4,240,789 A * 12/1980 Rosenthaler A61C 17/043
 433/136
 4,259,067 A 3/1981 Nelson
 4,425,911 A 1/1984 Luomanen et al.
 4,495,945 A 1/1985 Liegner
 4,583,527 A 4/1986 Musicant et al.
 4,592,344 A 6/1986 Scheer
 4,643,172 A 2/1987 Taff et al.
 4,802,851 A 2/1989 Rhoades
 4,865,545 A 9/1989 La Rocca
 D303,834 S 10/1989 Collins
 4,906,188 A 3/1990 Moseley
 4,975,057 A 12/1990 Dyfvermark
 4,992,046 A 2/1991 Sharp
 4,996,976 A 3/1991 Nakagawa
 5,009,595 A 4/1991 Osborn
 5,071,347 A 12/1991 McGuire
 5,078,602 A 1/1992 Honoshofsky
 5,127,411 A 7/1992 Schoolman et al.
 5,152,686 A 10/1992 Duggan
 5,232,362 A 8/1993 Kanas
 5,281,134 A 1/1994 Schultz
 5,366,489 A 11/1994 Burgio et al.
 5,438,976 A 8/1995 Nash
 5,462,435 A 10/1995 Young
 5,496,363 A 3/1996 Burgio et al.
 5,513,986 A 5/1996 Feltham et al.
 5,516,286 A 5/1996 Kushner
 5,588,836 A 12/1996 Landis et al.
 5,725,370 A 3/1998 Himeno et al.
 5,762,496 A 6/1998 Albertsson et al.
 5,769,635 A 6/1998 Eldreth
 5,827,061 A * 10/1998 Goodman A61C 17/043
 433/93
 5,873,718 A 2/1999 Sullivan
 5,890,899 A 4/1999 Sclafani
 5,924,866 A 7/1999 Eldreth et al.
 6,022,214 A * 2/2000 Hirsch A61B 1/24
 433/140
 6,149,430 A 11/2000 Nemetz et al.
 6,193,513 B1 2/2001 Pancallo
 6,213,772 B1 * 4/2001 Costello A61C 17/043
 433/140
 6,244,866 B1 6/2001 Campbell
 6,267,591 B1 7/2001 Barstow

6,338,627 B2 * 1/2002 Hirsch A61C 5/14
 433/140
 6,379,147 B1 4/2002 Georgakis et al.
 6,575,746 B2 6/2003 Hirsch et al.
 6,634,884 B2 10/2003 Phillips
 6,652,276 B2 11/2003 Fischer et al.
 6,655,960 B2 12/2003 Fischer
 6,716,029 B2 4/2004 Fischer et al.
 D491,663 S 6/2004 Bat-Genstein
 6,743,017 B2 6/2004 O'Neill
 D495,799 S 9/2004 Hirsch
 6,908,308 B2 6/2005 Hirsch et al.
 6,939,134 B2 9/2005 Sherry et al.
 6,974,321 B2 * 12/2005 Hirsch A61C 5/14
 433/140
 6,981,870 B2 1/2006 Heasley
 7,077,652 B2 7/2006 Kilcher et al.
 D556,327 S 11/2007 Albelda
 7,293,990 B2 11/2007 Hirsch et al.
 7,335,023 B2 * 2/2008 Mahlmann A61C 17/043
 433/136
 7,611,354 B2 * 11/2009 Hirsch A61C 1/088
 433/93
 7,748,981 B2 7/2010 Hirsch et al.
 8,029,280 B2 * 10/2011 Black A61C 17/043
 433/140
 8,057,227 B2 11/2011 Hirsch et al.
 8,057,228 B2 11/2011 Hirsch et al.
 8,075,310 B2 12/2011 Hirsch et al.
 8,297,973 B2 10/2012 Hirsch et al.
 8,852,169 B2 * 10/2014 Milo A61C 17/043
 433/91
 8,911,232 B2 * 12/2014 Nguyen A61C 17/0208
 433/136
 2004/0033468 A1 2/2004 Fischer
 2006/0063129 A1 3/2006 Hirsch
 2007/0231773 A1 10/2007 Pontynen et al.
 2007/0259307 A1 11/2007 Quan et al.
 2008/0318183 A1 12/2008 Suzman
 2009/0246728 A1 * 10/2009 Hirsch A61C 5/14
 433/36
 2011/0311942 A1 12/2011 Black et al.
 2014/0212837 A1 7/2014 Nguyen et al.
 2014/0212838 A1 7/2014 Nguyen et al.
 2014/0212839 A1 7/2014 Nguyen et al.
 2014/0212840 A1 7/2014 Nguyen et al.
 2014/0212841 A1 7/2014 Nguyen et al.

OTHER PUBLICATIONS

International Search Report and Written Opinion of PCT/US2009/000903, European Patent Office, Jul. 22, 2009, 8 pages.
 Frias Rdh, Mark, "Isolation vs. IsoDry", Jul. 3, 2011, accessed on Jan. 7, 2016 at <http://markrdh.com/?p=147>, 6 pages.

* cited by examiner

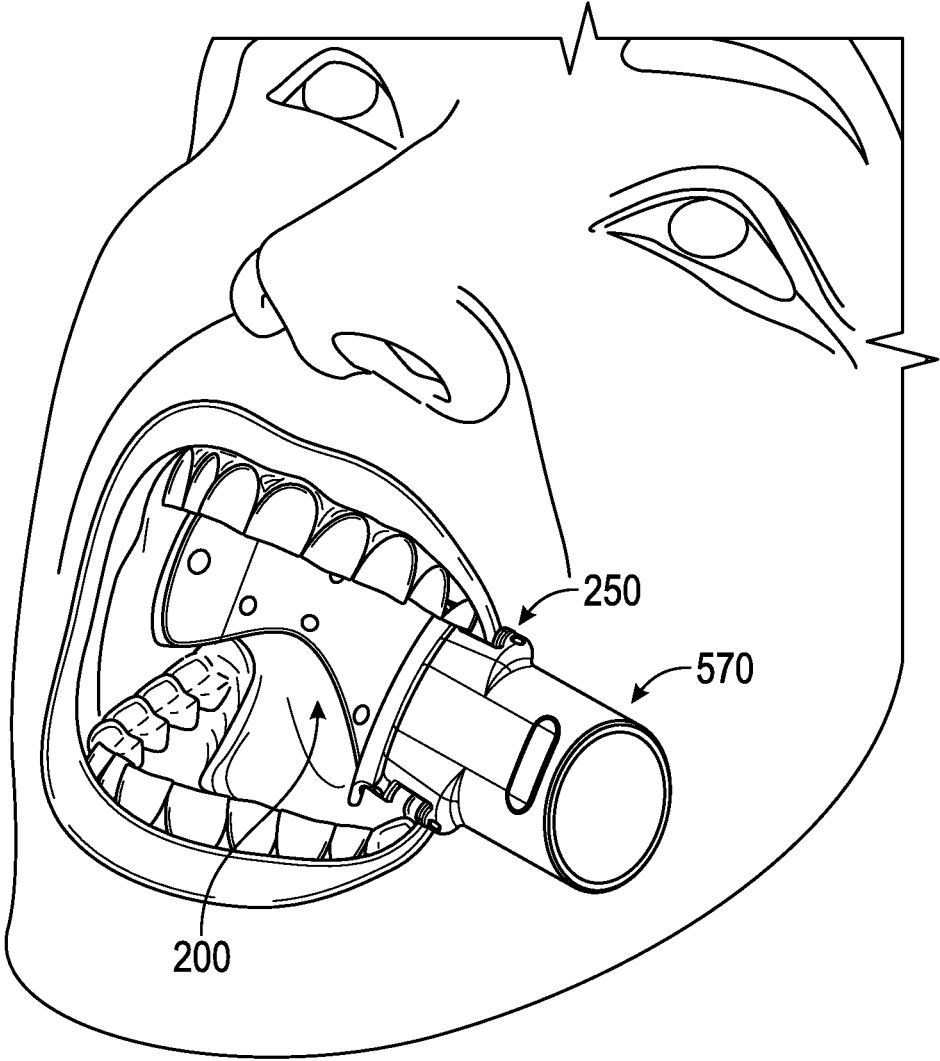

FIG. 1

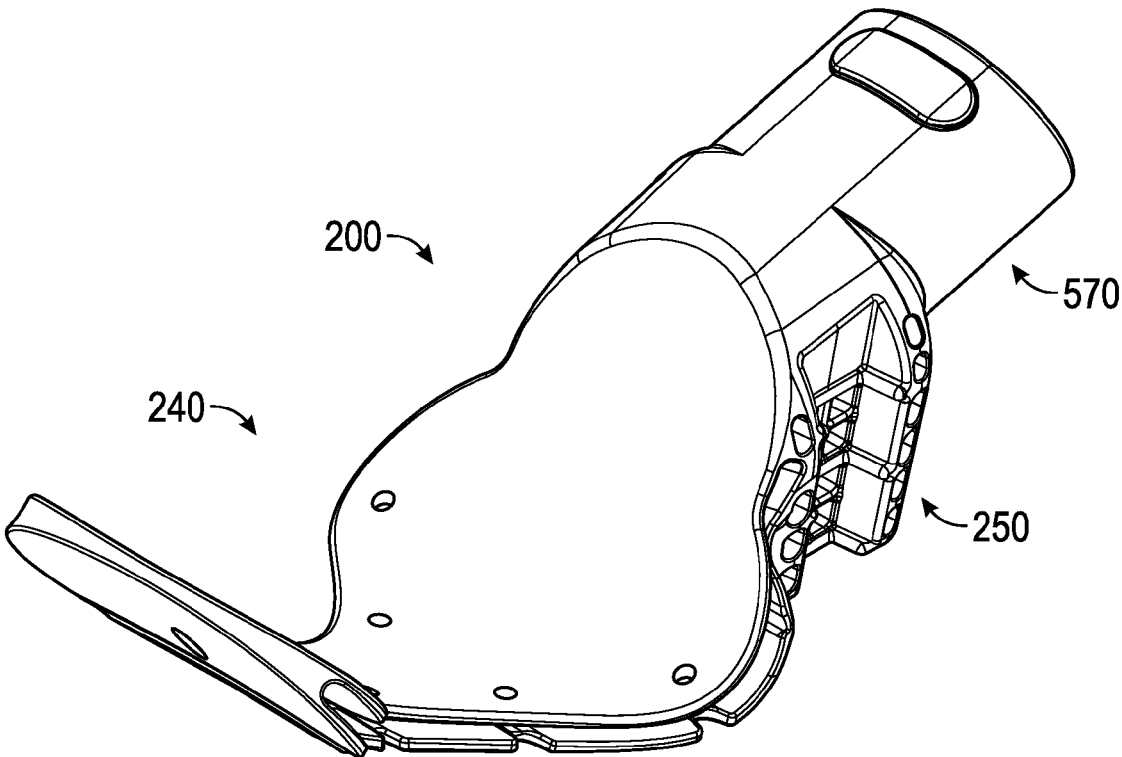

FIG. 2

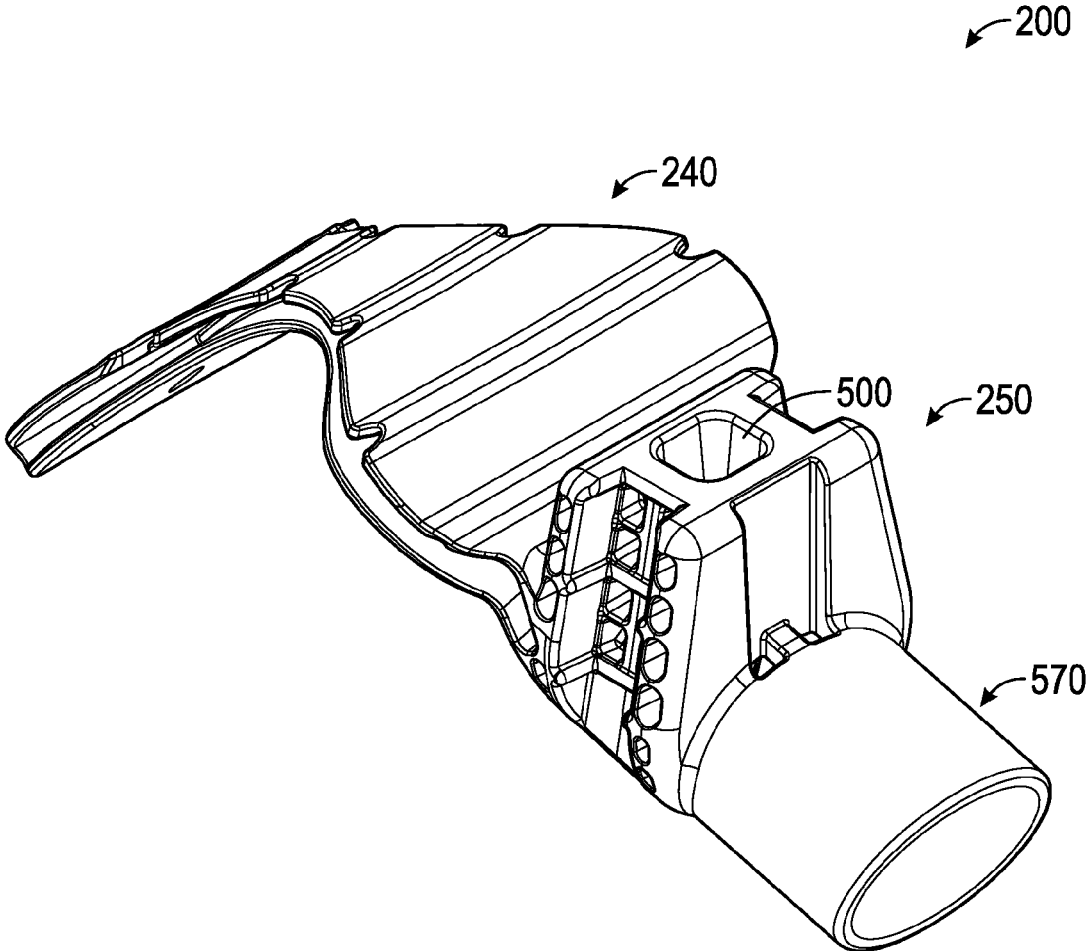

FIG. 3

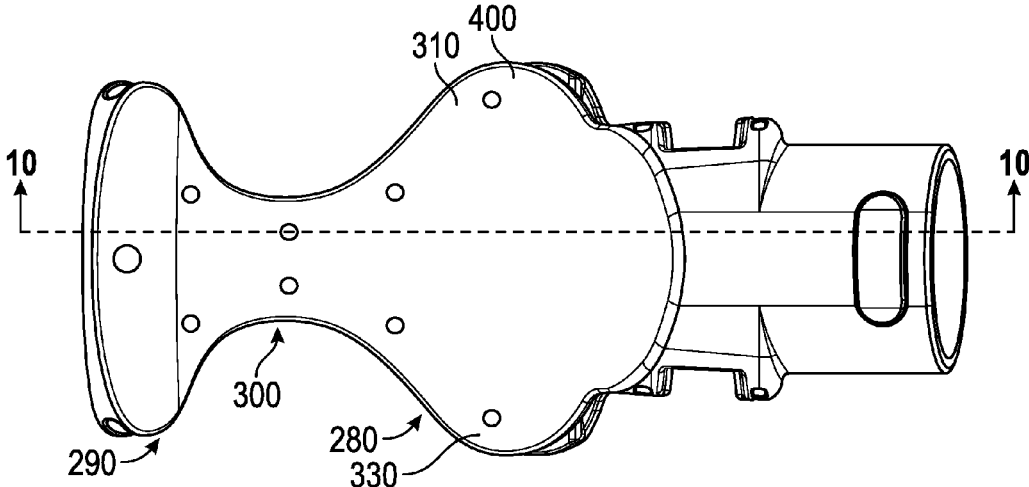

FIG. 4

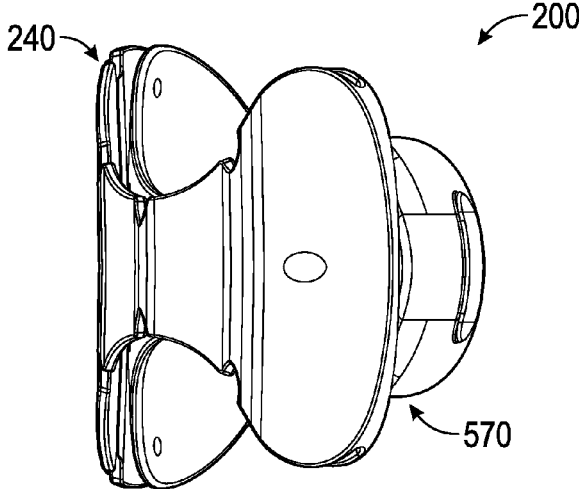

FIG. 5

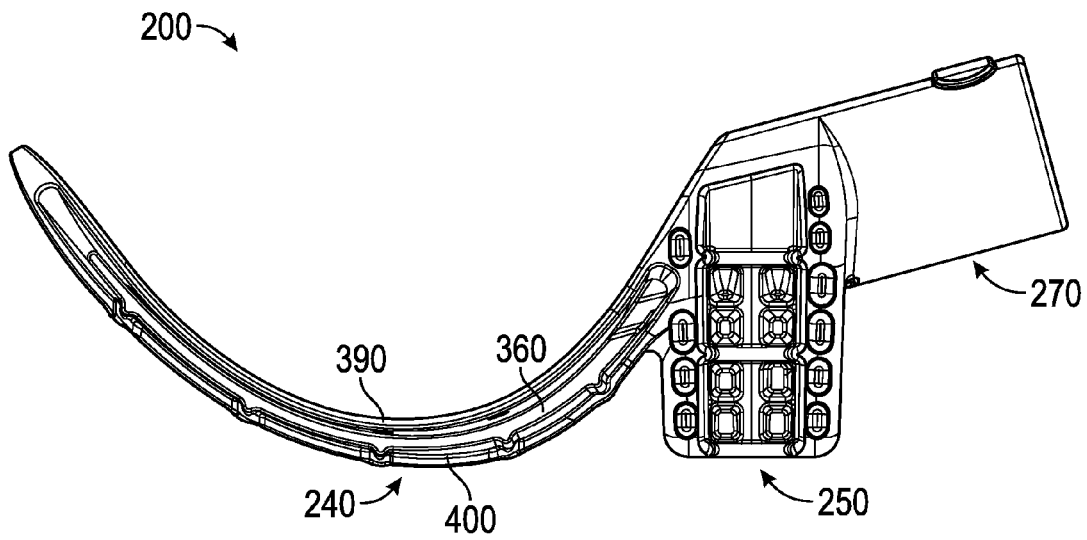

FIG. 6

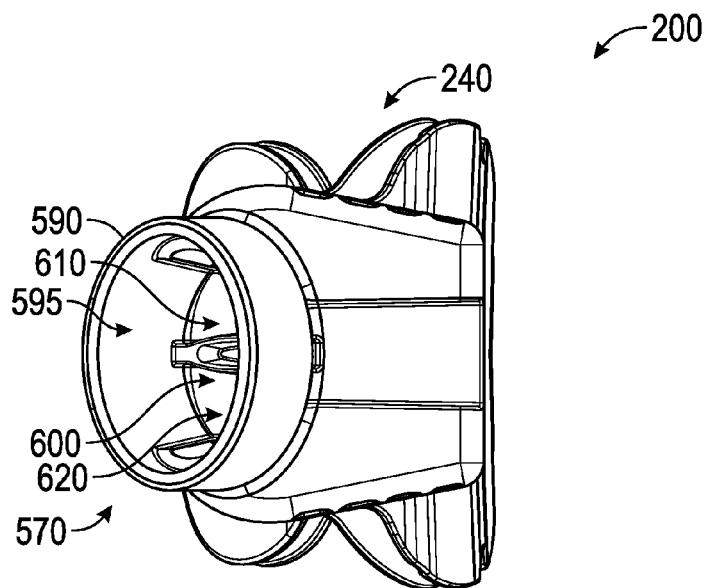

FIG. 7

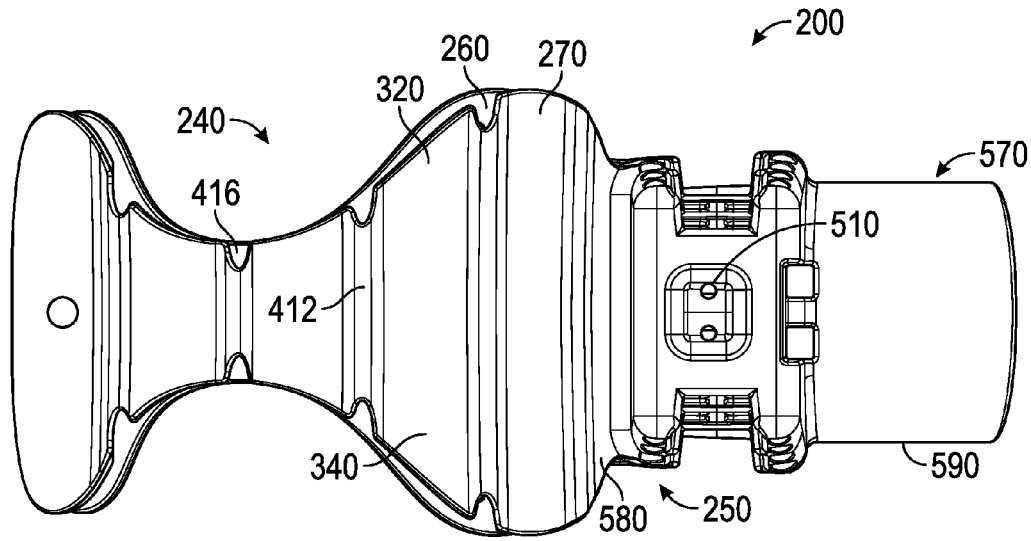

FIG. 8

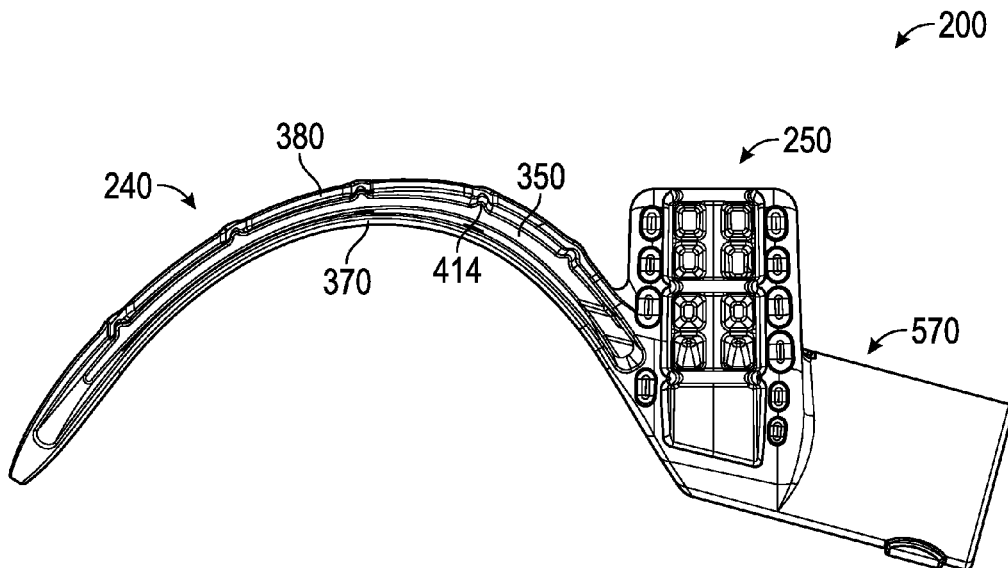

FIG. 9

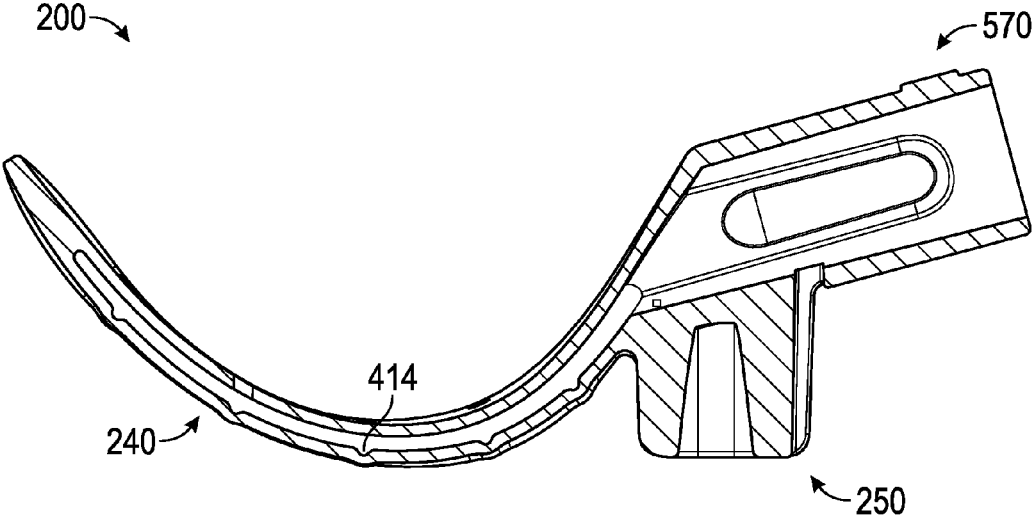

FIG. 10

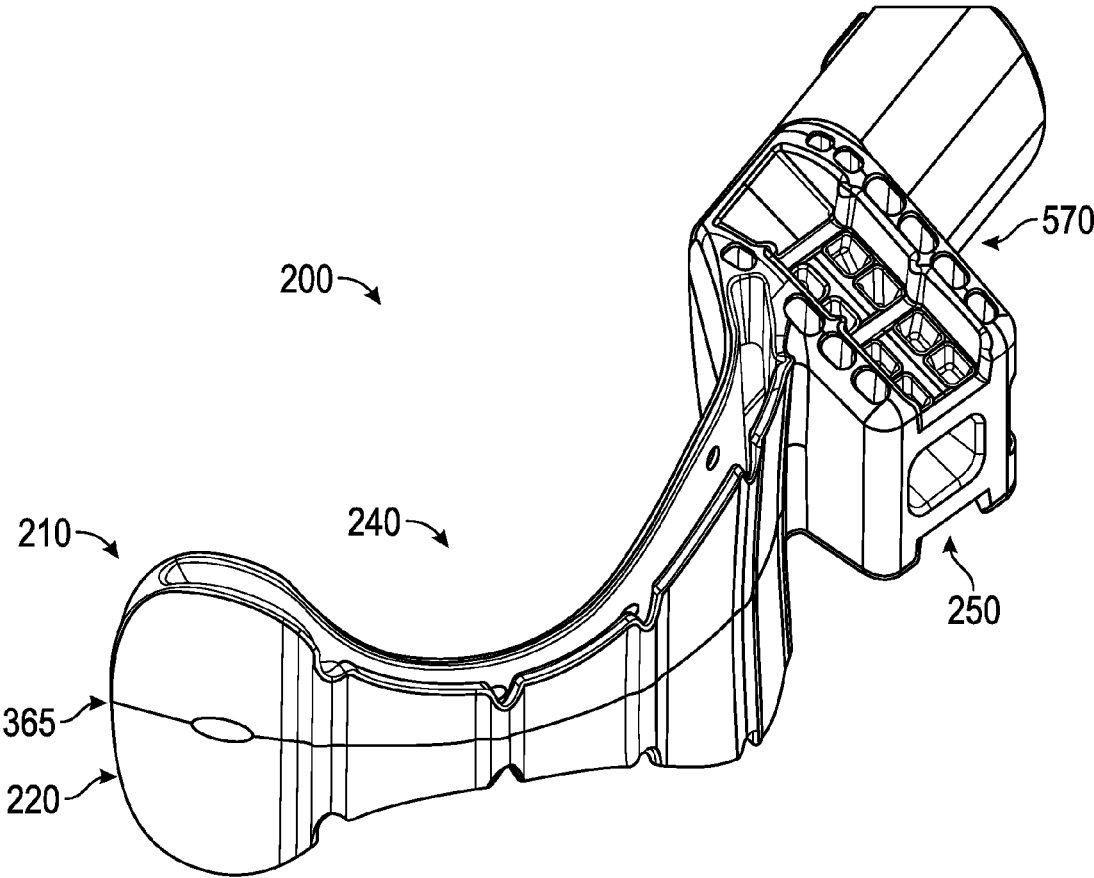

FIG. 11

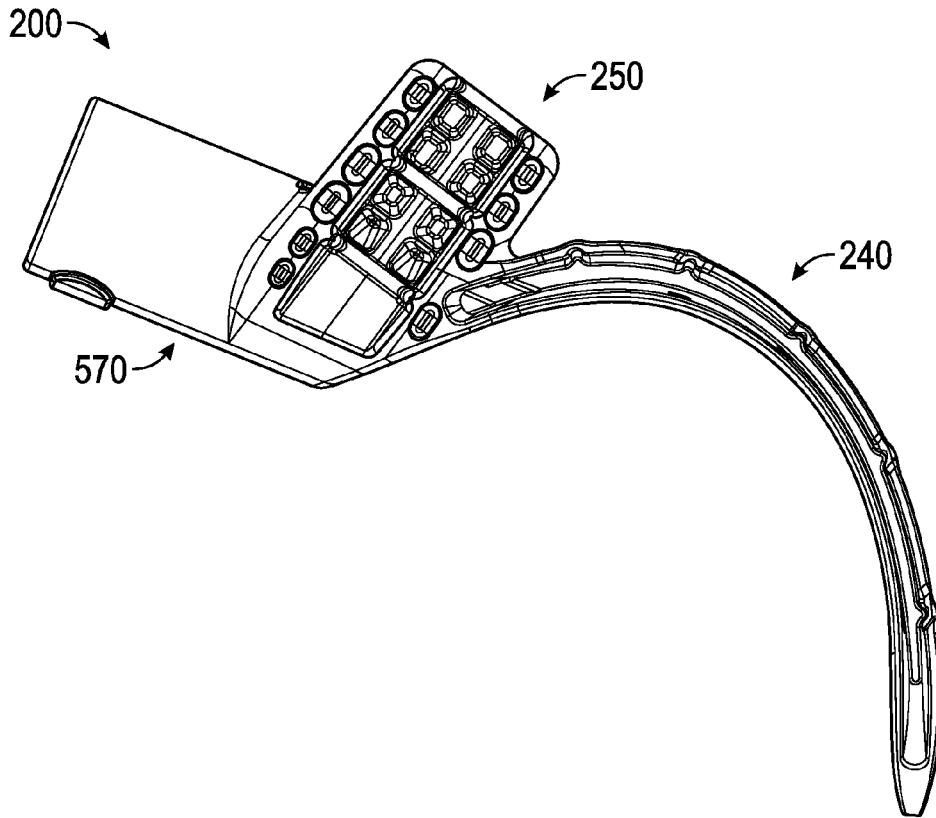

FIG. 12

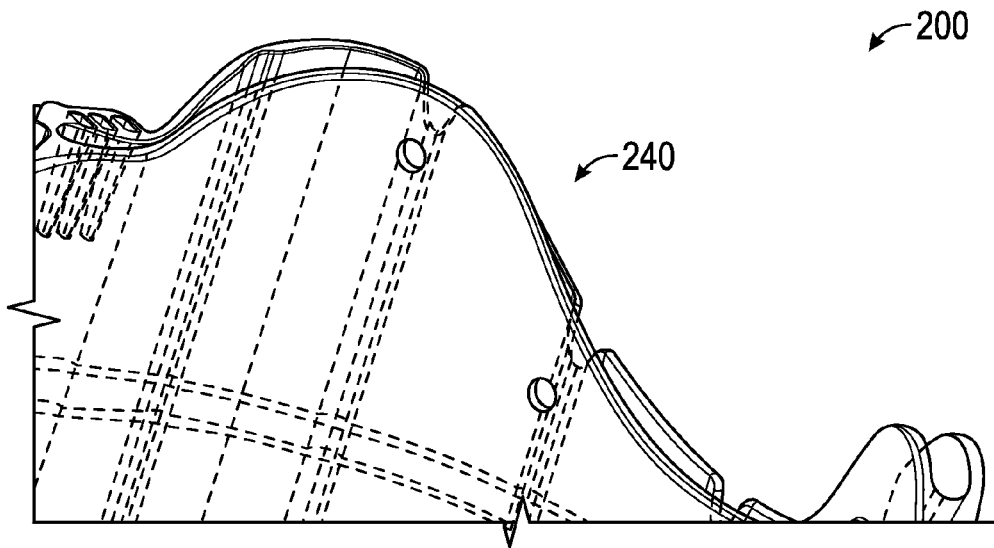

FIG. 13

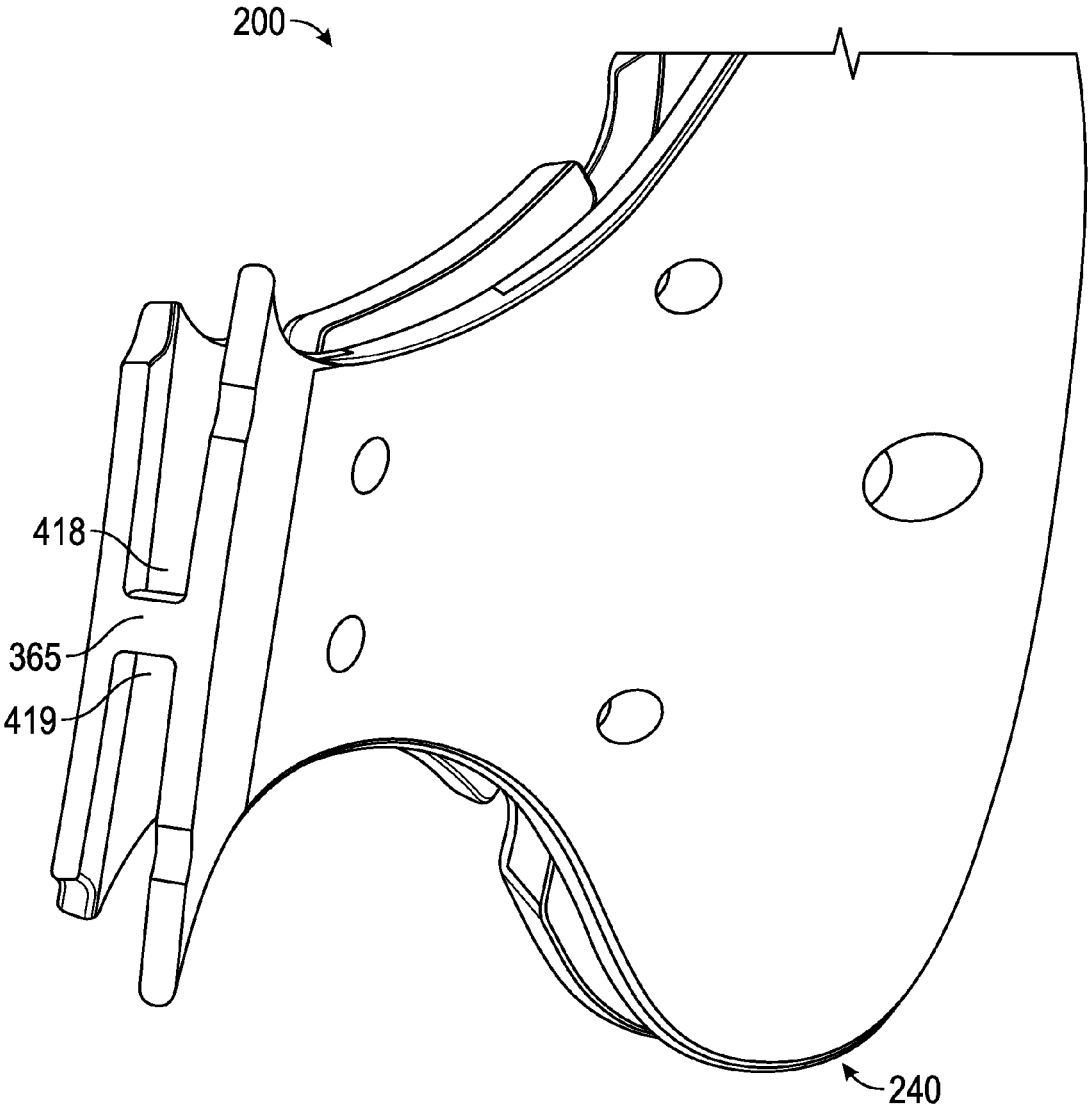

FIG. 14

1

INTRAORAL DEVICE AND METHOD OF USE

CROSS-REFERENCE TO RELATED APPLICATION

This application is a continuation of pending application Ser. No. 14/285,248 filed May 22, 2014.

FIELD OF THE INVENTION

The invention relates, in general, to dental appliances, and, in particular, to dental appliances for vacuum suction of the mouth of a dental patient for examination and/or operative purposes.

BACKGROUND OF THE INVENTION

During dental examination and/or operation, a number of fluids, e.g., saliva from the parotid gland, blood, water from the dental equipment, are produced in the patient's mouth. It is important to remove these fluids for the comfort of the patient, to prevent fluids and material from being aspirated into the throat or lungs of the patient, and to assist the health care provider in observing and/or operating within the patient's mouth.

SUMMARY OF THE INVENTION

An aspect of the invention involves an intraoral device that removes fluids from all areas of the mouth, e.g., operating side, vestibule area on the operation side, the lingual vestibule (along the side of the tongue), contralateral side vestibule, eliminating the need for constant patient mouth rinsing and the need for a dental assistant to aspirate debris.

Another aspect of the invention involves an intraoral device comprising a flexible body comprising an upper front flap including evacuation holes and an upper edge; an upper rear flap forming an upper pocket with the upper front flap and including internal channels and an upper edge separated from the upper edge of the upper front flap to form an upper pocket opening, the internal channels terminating in grooves along the upper edge; a lower front flap including evacuation holes and a lower edge; a lower rear flap forming a lower pocket with the lower front flap and including internal channels and a lower edge separated from the lower edge of the lower front flap to form a lower pocket opening, the internal channels terminating in grooves along the lower edge, wherein in a non-vacuum state the upper pocket opening and lower pocket opening are open and in a vacuum state the upper pocket opening and lower pocket opening are substantially sealed closed so that aspiration of fluids from the patient's mouth occurs through the evacuation holes in the front flaps and grooves, which become fluid inlets for drawing fluids through the channels, of the rear flaps.

One or more implementations of the above aspect of the invention include one or more of the following: the evacuation holes are in the front flaps and not in the rear flaps; the grooves are in the rear flaps at an intersection of the edges and the internal channels of the rear flaps and not in the front flaps; the internal channels are vertical channels; the internal channels form corresponding external ridges in the rear flaps; the evacuation holes communicate with and are aligned with the internal channels; the intraoral device includes a horizontally and longitudinally extending spine, an upper internal evacuation channel disposed above the

2

spine in the upper pocket, and a lower internal evacuation channel disposed below the spine in the lower pocket; and/or the intraoral device includes an upper portion above the spine and a lower portion below the spine that are vertically symmetrical.

Another aspect of the invention involves a method of using the intraoral device of the aspect of the invention (or one or more implementations) described above. The method comprises inserting the intraoral device into the patient's mouth so that the upper edges of the upper flaps contact an upper part of the patient's mouth and the lower edges of the lower flaps contact a lower part of tongue within the mouth of the patient; applying vacuum state to the intraoral device so that the upper pocket opening and lower pocket opening are substantially sealed closed and the grooves become fluid inlets for drawing fluids through the channels; and aspirating fluids from the patient's mouth through the evacuation holes in the front flaps and into the channels through the grooves.

Other, more particular features and advantages of the inventions are set forth in the following detailed description and drawings.

BRIEF DESCRIPTION OF THE DRAWINGS

The drawings illustrate both the design and utility of preferred embodiments of the present invention, in which similar elements are referred to by common reference numbers, wherein:

FIG. 1 is a front perspective view of an embodiment of the intraoral device shown inside a patient's mouth;

FIG. 2 is a front perspective view of the intraoral device;

FIG. 3 is a rear perspective view of the intraoral device;

FIG. 4 is a front elevational view of the intraoral device;

FIG. 5 is a left side elevational view of the intraoral device;

FIG. 6 is a bottom plan view of the intraoral device;

FIG. 7 is a right side elevational of the intraoral device;

FIG. 8 is a rear elevational view of the intraoral illumination device;

FIG. 9 is a top plan view of the intraoral device;

FIG. 10 is a cross-sectional view of the intraoral device taken along lines 10-10 of FIG. 4;

FIG. 11 is another rear perspective view of the intraoral device;

FIG. 12 is another plan view of the intraoral device;

FIG. 13 is a partial perspective view of the intraoral device;

FIG. 14 is another cross-sectional view of the intraoral device.

DETAILED DESCRIPTION OF PREFERRED EMBODIMENTS

With reference to FIGS. 1-14, an embodiment of an intraoral device 200 that removes fluids from all areas of a patient's mouth 202 will now be described. The intraoral device 200 is preferably a one-piece, flexible, integrated molded body made of a single homogeneous material or combination of materials. The intraoral device 200 is preferably molded out of a translucent (e.g., transparent), flexible, soft, elastic, resilient, biocompatible thermoplastic elastomer. The intraoral device 200 is also vertically symmetrical so that an upper portion 210 is symmetric with respect to a lower portion 220 relative to spine 365. This allows the same intraoral device 200 to be positioned on either the left side or the right side of the patient's mouth. The intraoral device 200 may also come in different sizes for

different-size mouths. The intraoral device 200 is also disposable after each use. The intraoral device 200 may be used to provide vacuum suction or the intraoral device 200 may be used to provide vacuum suction and illumination.

The single-piece intraoral device 200 generally includes integrated tongue and cheek retractor 240, bite piece 250, and connection section 570, each of which will be described in turn below. In alternative embodiments, one or more of the tongue and cheek retractor 240, bite piece 250, and connection section 570 are separate, connectable components.

The tongue and cheek retractor 240 has inner surfaces 260 and outer surfaces 270. The retractor 240 includes an incurved main body portion 280 and a forwardly angled cheek retractor (or "fish/whale tail") portion 290 joined by isthmus portion 300.

The retractor 240 includes an upper front flap 310, an upper rear flap 320, a lower front flap 330, and a lower rear flap 340. The front flaps 310, 330 and rear flaps 320, 340 are separated by an upper pocket opening or upper gap 350 and lower pocket opening or lower gap 360, respectively. The front flaps 310, 320 and the rear flaps 320, 340 (minus V-shaped grooves 416) respectively define envelopes that are the same and aligned with each other. The flaps 310, 320, 330, 340 all extend from and share a common, central spine 365. The spine 365 extends horizontally and longitudinally a majority of the length of the retractor 240 and divides the upper half 210 from the lower half 220 of the intraoral device 200. In addition to serving as the intersection location for the flaps 310, 320, 330, 340, in an embodiment of the intraoral device 200 where the intraoral device 200 is an intraoral illumination and vacuum suction device, the spine 365 may serve as a light pipe and act as a separator for an upper internal evacuation channel 418 above the spine 365 and a lower internal evacuation channel 419 below the spine 365.

In the embodiment shown, the front flaps 310, 330 have a flat, outer front surface with evacuation holes 410 therein and the rear flaps 320, 340 include curved, outwardly extending, vertical ridges 412 with no evacuation holes 410. On an interior surface of the ridges 412, respective incurved vertical channels 414 (with no evacuation holes 410, similar to ridges 412) are formed. In an alternative embodiment, an interior surface of the rear flaps 320, 340 include the incurved vertical channels 414 and an exterior surface of the rear flaps 320, 340 is substantially flat/smooth (i.e., does not include ridges 412). The evacuation holes 410 of the front flaps 310, 330 are vertically aligned with the ridges 412/channels 414, but the ridges 412/channels 414 do not include the evacuation holes 410. The ridges 412/channels 414 are not in the front flaps 310, 330. The channels 414 terminate at one end in spine 365 and at an opposite end terminate in V-shaped grooves or slots 416 in the rear flaps 320, 340 (at an intersection of the edges 380, 400 and the internal vertical channels 414 of the rear flaps 320, 340). There are no V-shaped grooves 416 in front flaps 310, 330. In an alternative embodiment, the grooves or slots 416 are U-shaped grooves. In further embodiments, the grooves 416 are only in front flaps 310, 330 or are in both the front flaps 310, 330 and the rear flaps 320, 340.

The ridges 412, which run along outer surface 270 of rear flaps 320, 340, terminate at opposite ends in the V-shaped grooves 416. In an alternative embodiment, there are no ridges 412, and V-shaped grooves 416 are smaller and simply cut into the flaps. The length of the channels 414 is about 1/2 the length of the ridges 412. In a preferred embodiment, the channels 414 and ridges 412 are vertical, not

angled, and are perpendicularly disposed relative to spine 365. In alternative embodiments, the channels 414/ridges 412 are angled relative to spine 365.

In use, when vacuum forces imparted to the intraoral device 200 by a vacuum source cause the front flaps 310, 330 and the rear flaps 320, 340 to be drawn together, the channels 414 of the rear flaps 320, 340 remain in communication with the interior of the patient's mouth through the V-shaped grooves 416 and the evacuation holes 410 along the front flaps 310, 330 remain in communication with both the channels 414 and the interior of the patient's mouth. Thus, the evacuation holes 410 in the front flaps 310, 330 and rearwardly extending ridges 412/channels 414/V-shaped grooves 416 in the rear flaps 320, 340, in combination, do not close with oral-tissue blocking areas in the patient's mouth. Not having evacuation holes in the rear flaps 320, 340, and especially not having evacuation holes in the rear flaps 320, 340 aligned with the evacuation holes 410 of the front flaps 320, 340 prevents spray from a water three-way syringe from passing through the intraoral device 200 and into the patient's throat.

FIG. 14 illustrate upper internal evacuation channel 418 and lower internal evacuation channel 419 adjacent the spine 365 that do not close (due to rigidity of spine 365) when the vacuum forces imparted to the intraoral device 200 by a vacuum source cause the front flaps 310, 330 and the rear flaps 320, 340 to be drawn together. FIG. 14 also illustrates the fluid path through the intraoral device 200 when the front flaps 310, 330 and the rear flaps 320, 340 are drawn together by the vacuum forces. The evacuation holes 410 in the front flaps 310, 330 and rearwardly extending ridges 412/channels 414/V-shaped grooves 416 in the rear flaps 320, 340, in combination, allow the upper internal evacuation channel 418 and lower internal evacuation channel 419 to be smaller than was possible in the past because of the improved communication between the channels 418/419 and interior of the patient's mouth caused by the evacuation holes 410, ridges 412/channels 414, and V-shaped grooves 416.

Although eight evacuation holes 410, four ridges 412, and eight channels 414 are shown, in alternative embodiments, the number and/or location of evacuation holes 410, ridges 412, and/or channels 414 may vary.

The upper front flap 310 and the upper rear flap 320 are configured to rest or flex against the palatal area or roof of the patient's mouth 36 during use. The upper roof of the mouth spans the upper gap 350 and pushes or bends the upper front flap 310 and the upper rear flap 320 forward to create a substantial seal along upper edges 370, 380, which are aligned with each other (excepted for the V-shaped grooves 416), creating a substantially sealed upper internal evacuation channel 418 in the upper gap 350, but yet still in communication with the patient's mouth through the evacuation holes 410 in the front flaps 310, 330 and the rearwardly extending ridges 412/channels 414/V-shaped grooves 416 in the rear flaps 320, 340. Similarly, the lower front flap 330 and the lower rear flap 340 are configured to rest or flex against the lingual area of mouth or tongue to keep the tongue protected and retracted during use. The tongue and floor of the patient's mouth span the lower gap 360 and forms a substantially seal along lower edges 390, 400, which are aligned with each other (excepted for the V-shaped grooves 416), creating a substantially sealed lower internal evacuation channel in the lower gap 360, but yet still in communication with the patient's mouth through the evacuation holes 410 in the front flaps 310, 330 and the rearwardly extending ridges 412/channels 414/V-shaped grooves 416 in the rear flaps 320, 340. Thus, in a non-vacuum state, the

5

upper pocket opening **350** and lower pocket opening **360** are open and in a vacuum state the upper pocket opening **350** and lower pocket opening **360** are substantially sealed closed so that aspiration of fluids from the patient's mouth occurs through the evacuation holes **410** in the front flaps **310, 330** and the V-shaped grooves **416**, which become fluid inlets for drawing fluids through the vertical channels **414**, of the rear flaps **320, 340**.

The cheek retractor portion **290** has an angled, curved, generally fish/whale-tail shape. In use, the cheek retractor portion **290** is flexed inward towards the main body portion **280** and rests against the inner cheek tissue between the cheek tissue and the outside of the teeth. With the cheek retractor portion **290** flexed, the upper flaps **310, 320** and lower flaps **330, 340** are closed together, forming a substantial seal along the upper edges **370, 380** and the lower edges **390, 400** of the retractor **240** adjacent where the isthmus portion **300** and cheek retractor portion **290** join, but yet still in communication with the patient's mouth through the evacuation holes **410** in the front flaps **310, 330** and the rearwardly extending ridges **412/channels 414/V-shaped grooves 416** in the rear flaps **320, 340**.

When the tongue and cheek retractor **240** is positioned within the patient's mouth (similar to that shown in FIG. 1), the flexed upper flaps **310, 320**, the flexed lower flaps **330, 340**, and the flexed cheek retractor portion **290** form an envelope for isolating an area of interest in the patient's mouth and protect the upper roof, tongue and cheek of the patient's mouth from instruments such as dental drills during the dental procedure and prevent aspiration of debris or dropped items into the patient's throat.

The bite piece **250** includes symmetric, opposite tooth-engaging portions joined by an intermediate connection portion and allows for flexible, resilient, elastic movement of the tooth engaging portions in vertical, longitudinal, and lateral directions with respect to each other to allow vertical, longitudinal, and lateral biting movement by the patient for maximum biting comfort. The bite piece **250** includes a suction cavity **500** and a pair of vacuum holes **510** to allow a vacuum force to be provided in the cavity **500** for suctioning fluids in the area of the retro molar pad and the maxillary tuberosity of the patient's mouth.

The connection section **570** extends from the bite piece **250** and a proximal portion **580** of the retractor **240**. The connection section **570** is configured to extend outside of a patient's mouth and attach to a multi-lumen vacuum connector/device for delivering vacuum suction (or vacuum suction and illumination) to the intraoral device **200**.

The connection section **570** includes an open-ended tube **590** having a generally elliptical cross-section that tapers slightly in height as the tube **590** intersects the bite piece **250** and the proximal portion **580** of the retractor **240**. An interior of the open-ended tube **590** defines a main vacuum channel **595**. Adjacent the bite piece **250** and the proximal portion **580** of the retractor **240**, the connection section **570** includes a cylindrical tube-shaped illumination connector **600** for transmitting light to the spine **365** and for supporting a plug portion of a vacuum connector. On opposite vertical sides of the illumination connector **600**, where the illumination connector **600** joins the proximal portion **580** of the retractor **240**, upper and lower vacuum ports **610, 620** communicate the main vacuum channel **595** with the upper and lower internal evacuation channels **418, 419** of the retractor **240**. The main vacuum channel **595** communicates with the suction cavity **500** through the vacuum holes **510**.

In use, the intraoral device **200** is inserted into the patient's mouth **202** so that the upper edges **370, 380** of the

6

upper flaps **310, 320** contact an upper part of the patient's mouth **202** and the lower edges **390, 400** of the lower flaps **330, 340** contact a lower part of tongue within the mouth **202** of the patient; a vacuum state is applied to the intraoral device **200** so that the upper pocket opening **350** and lower pocket opening **360** are substantially sealed closed and the V-shaped grooves **416** become fluid inlets for drawing fluids through the vertical channels **414**; and fluids from the patient's mouth are aspirated through the evacuation holes **410** in the front flaps **310, 330** and into the vertical channels **414** through the V-shaped grooves **416**.

Although this invention has been described in terms of certain preferred embodiments, other embodiments apparent to those of ordinary skill in the art are also within the scope of this invention. Accordingly, the scope of the invention is intended to be defined only by the claims that follow.

What is claimed is:

1. An intraoral device, comprising:

a flexible body, comprising:

an upper front flap including an upper edge;

an upper rear flap forming an upper pocket with the upper front flap, the upper rear flap including an upper edge separated from the upper edge of the upper front flap to form an upper pocket opening; at least one of the upper front flap and the upper rear flap including internal channels;

a lower front flap including a lower edge;

a lower rear flap forming a lower pocket with the lower front flap, the lower rear flap including a lower edge separated from the lower edge of the lower front flap to form a lower pocket opening;

at least one of the lower front flap and the lower rear flap including internal channels;

wherein the internal channels of at least one of the upper front and rear flaps and the lower front and rear flaps terminating in grooves along at least one of the upper edges and the lower edges, in a non-vacuum state the upper pocket opening and lower pocket opening are open, and in a vacuum state the upper pocket opening and lower pocket opening are substantially sealed closed so that aspiration of fluids from a patient's mouth occurs through the grooves, which become fluid inlets for drawing fluids through the internal channels.

2. The intraoral device of claim 1, further including evacuation holes in at least one of the front flaps and the rear flaps.

3. The intraoral device of claim 2, wherein the evacuation holes are in the front flaps and not in the rear flaps.

4. The intraoral device of claim 2, wherein the evacuation holes communicate with and are aligned with the internal channels.

5. The intraoral device of claim 1, wherein the grooves are in the rear flaps at an intersection of the edges and the internal channels of the rear flaps and not in the front flaps.

6. The intraoral device of claim 1, wherein the internal channels are vertical channels.

7. The intraoral device of claim 1, wherein the internal channels form corresponding external ridges in the rear flaps.

8. The intraoral device of claim 1, wherein the intraoral device includes a horizontally and longitudinally extending spine, an upper internal evacuation channel disposed above the spine in the upper pocket, and a lower internal evacuation channel disposed below the spine in the lower pocket.

9. The intraoral device of claim 8, wherein the intraoral device includes an upper portion above the spine and a lower portion below the spine that are vertically symmetrical.

10. The intraoral device of claim 1, wherein the lower rear flap and the upper rear flap define a profile, the lower front flap and the upper front flap define a profile, and the profile of the lower rear flap and the upper rear flap is the same as the profile of the lower front flap and the upper front flap except for the grooves.

11. A method of using the intraoral device of claim 1, comprising: inserting the intraoral device into a patient's mouth so that an upper edge of an upper flap contacts an upper part of the patient's mouth and the lower edges of the lower flaps contact a lower part of a tongue within the mouth of the patient; applying vacuum state to the intraoral device so that the upper pocket opening and lower pocket opening are substantially sealed closed and the grooves become fluid inlets for drawing fluids through the channels; aspirating fluids from the patient's mouth through the grooves in the intraoral device.

* * * * *