

UNITED STATES PATENT AND TRADEMARK OFFICE

BEFORE THE PATENT TRIAL AND APPEAL BOARD

EVENFLO COMPANY, INC.

Petitioner

v.

BABY JOGGER, LLC,

Patent Owner.

IPR2025-01122

Patent 11,731,682

PATENT OWNER'S
DISCRETIONARY DENIAL BRIEF

TABLE OF CONTENTS

I. Introduction1

II. Factual Background.....2

 A. Origin of the Invention.....2

 B. Prosecution of the Patents3

 C. Petitioner Follows Baby Jogger’s Lead with Notice of the Patents.....5

III. *Fintiv*-Based and PTAB Workload Management Memo Discretionary Denial Factors6

 A. The Settled Expectations of the Parties Weigh in Favor of Discretionary Denial.....6

 B. Petitioner’s Extensive Reliance on Voluminous Expert Testimony Favors Denial.....9

 C. The *Fintiv* Factors favor discretionary denial.....11

 D. Balancing all Factors Favors Denial14

IV. Section 325(d) Favors Discretionary Denial.....15

V. Conclusion.....18

PATENT OWNER'S EXHIBIT LIST

Exhibit No.	Description
2001	<i>RESERVED</i>
2002	Excerpt of File History of Application No. 12/631,375, Applicant's Response to Office Action, Remarks and Attachments (Nov. 4. 2013)
2003	United States District Courts—National Judicial Caseload Profile for 12-month period ending December 31, 2024; <i>available at</i> https://www.uscourts.gov/sites/default/files/2025-02/fems_na_distprofile1231.2024.pdf
2004	U.S. Patent No. 10,449,987, Information Disclosure Statement dated February 28, 2018
2005	<i>RESERVED</i>
2006	<i>RESERVED</i>
2007	Docket Sheet (as of Sept. 1, 2025) for <i>Baby Jogger, LLC v. Evenflo Company, Inc.</i> , No. 1:24-cv-00723 (D. Del. filed June 18, 2024)
2008	<i>RESERVED</i>
2009	<i>RESERVED</i>
2010	<i>RESERVED</i>

I. INTRODUCTION

Patent Owner Baby Jogger, LLC (“Baby Jogger”) respectfully requests that the Director exercise discretion and deny institution in two *inter partes* review proceedings, IPR2025-01122 (“the 122 IPR”) and IPR2025-01140 (“the 140 IPR”), challenging U.S. Patent Nos. 11,731,682 (“the ’682 Patent”), and 11,577,771 (“the ’771 Patent”), respectively (collectively, “the Patents”).¹ The Petitions challenge patents that are part of a patent family with years of accrued settled expectations, rely on unmanageably voluminous “expert” testimony and references identical to or similar to those already cited and/or considered by the Examiner, and theories that are more efficiently and appropriately addressed in the parallel district court proceedings. The Director should grant this request for discretionary denial.

¹ This brief addresses both proceedings and is identically filed in each (other than case style/headers). Non-identical Papers and exhibits in each IPR are referenced by the IPR number followed by the document, while duplicated exhibits are referenced by number only. E.g., “122 IPR Ex-1048” or “140 IPR Ex-1048” versus “Ex-1014.”

II. FACTUAL BACKGROUND

A. Origin of the Invention

The origins of the Patents began around 2008, when Baby Jogger—a leading innovator of baby strollers since 1984—developed and introduced the first true convertible single-to-double stroller. Before this invention, parents with multiple children were limited to either using two separate strollers or buying existing double strollers that suffered from significant drawbacks. Some existing double strollers were too large, making them difficult to maneuver. Ex-1031 (Part 3), 65.² Others included a second seat tucked beneath the first seat that was small, cramped, and reduced the stroller’s storage capacity. *Id.* at 70. Still other models had components that were permanently affixed and did not permit reversibility or interchangeability of the seat. *Id.* at 65.

Baby Jogger overcame these limitations by developing a novel modular stroller system capable of seamlessly alternating between single- and double-seat configurations without expanding the stroller’s overall footprint. One aspect of the patented Baby Jogger stroller system, known commercially as the “City Select,” was its seat attachments, which allowed a second seat to be added directly to the

² Petitioner did not number this exhibit, so page references are to the PDF page number.

frame of the single stroller, converting it into a double stroller while preserving both its stability and maneuverability. Ex-1004, Abstract, 1:14-23. Within months of its introduction in 2009, the City Select won numerous awards for its innovative design, which Baby Jogger was actively seeking to patent. Ex-1014, 327 (response to office action noting awards supported secondary considerations); *see also* Ex-2002 (providing copies of NPL awards not included in Petitioner's exhibits).

B. Prosecution of the Patents

Baby Jogger filed its initial provisional application related to the City Select in 2008. Ex-1002. Since that time, this patent family has undergone years of intensive review, examination, and negotiation between Baby Jogger and the Patent Office. Notably, the entire patent family (all of which claim priority to the first provisional application) was examined by the same Examiner, who was familiar with the state of the art and repeatedly allowed the claims in this patent family.

U.S. Patent No. 8,955,869 (“the ’869 Patent”) is the earliest granted patent in this family, issuing more than ten years ago, on February 17, 2015.³ Ex-1004. It was filed as a continuation of Application No. 12/631,375 (“the ’375

³ The ’869 Patent and four additional related patents are also subjects of petitions and Patent Owner's Requests for Discretionary Denial in IPR2025-01105, -01106, -01100, -01095, and -01120.

Application”). During prosecution of the ’375 Application, the Examiner rejected the claims as anticipated and obvious over multiple prior art references, many of which mirror those now cited by Petitioner. *See* Ex-1014, 94-115, 180-99, 268-93; 122 IPR Pet. 25-32; 140 IPR Pet. 21-28. The Examiner ultimately allowed the claims, though the applicant later withdrew the ’375 Application from issue. Ex-1014, 333-43, 520-27. The application for the ’869 Patent was then filed with a preliminary amendment aligning its claims with those already allowed in the ’375 Application. Ex-1015, 52-58. Unsurprisingly, the Examiner allowed the ’869 claims following a telephonic interview and minor amendments.

U.S. Patent No. 9,403,550 (“the ’550 Patent”), which issued in August 2016, is a continuation of the ’869 Patent. During prosecution, it was also subject to multiple office actions, including anticipation and obviousness rejections. Ex-1016, 49-56, 117-24, 172-76. Notably, the Examiner cited prior art that Petitioner now relies on in these petitions. Ex-1016, 57 (Rolicki); 122 IPR Pet. 32 (Ground 1 citing Rolicki); 140 IPR Pet. 28 (Ground 1 citing Rolicki).

The ’682 Patent, which claims priority to the ’869 Patent, published on December 10, 2020, and was subjected to a rigorous prosecution. Ex-1010, code (65). The Examiner issued multiple rejections, including relying on U.S. Patent D593,459 (“Liao”), the same reference relied on by Petitioner in the 122 IPR. *See*,

IPR2025-01122

e.g., 122 IPR Pet. 8, 56-68; *see also* Ex-1020 (Part 1), 340-43, 492-93; Ex-1020 (Part 2), 684-86. Ultimately, the '682 Patent issued on August 22, 2023. Ex-1010.

The '771 Patent is a continuation of the '682 Patent and published on November 24, 2022. Ex-1011, code (65). It issued on February 14, 2023, after an applicant-initiated interview and amendments, with the Examiner again citing cumulative art that Petitioner relies on in related IPRs. Ex. 1011; Ex. 1021 (Part 1), 239-252 (citing US 2010/0013281 (Chen), relied on in both IPR2025-01105 and IPR2025-01106).

C. Petitioner Follows Baby Jogger's Lead with Notice of the Patents

In or around 2018, Petitioner introduced its Pivot Xpand Travel System and its Pivot Xpand Second Seat, which permitted its strollers to be converted into double strollers. This single-to-double product falls within the scope of the claims of the Patents. Notably, Petitioner has been aware of the patent family for more than seven years, citing both the parent '869 Patent and '550 Patent in an IDS on February 28, 2018. Ex-2004. Consequently, Petitioner developed and sold its products for at least seven years with actual knowledge of the Baby Jogger patent family.

In the years since Baby Jogger first introduced its stroller system, it has continued to refine, protect, and commercialize its inventions. On June 18, 2024, Baby Jogger decided to put an end to Petitioner's willful infringement of the

Patents and filed a patent infringement action against Petitioner, asserting the Patents and those in the related IPRs. Ex-2007.

III. FINTIV-BASED AND PTAB WORKLOAD MANAGEMENT MEMO DISCRETIONARY DENIAL FACTORS

Institution should be denied under § 314(a) in view of the strong settled expectations of the patent owner, Baby Jogger, the *Fintiv* factors, and the heavy burden imposed on the Office (and Baby Jogger) by the voluminous petitions and expert declarations, all of which weigh in favor of discretionary denial.⁴ Taken together, these factors support a single conclusion: institution would be unjustified and an inefficient use of the Office's resources.

A. The Settled Expectations of the Parties Weigh in Favor of Discretionary Denial

The Patents are part of a larger family of patents that have been commercialized in a core Baby Jogger product for 15 years. The '550 Patent and '869 Patent have been in force for 9–10 years, respectively, and have developed strong settled expectations. *Dabico Airport Solutions Inc v. HydraFacial LLC*, IPR2025-00408, Paper 21, 3 (June 18, 2025). Petitioner had actual notice of the '869 and '550 Patents, as it cited them on an IDS in February 2018. *See supra*

⁴ The expert's doorstopper declarations in these 2 IPRs alone (not including the other 5 related IPRs) have approximately 300 pages and 584 paragraphs *each*.

Section II.C. (citing Ex-2004). In the years since, Baby Jogger has pursued several continuations to protect its innovation, including those that issued as the challenged patents. And Petitioner markets stroller products comparable to those offered by Baby Jogger within the same market and to many of the same customers. Thus, Baby Jogger has strong settled expectations in this family of patents, including the ones challenged here. *See Samsung Elecs. Co. v. iCashe, Inc.*, IPR2025-00639, Paper 12, 3 (Aug. 14, 2025) (inefficient use of Board resources to consider validity of 2 newer patents when validity of 5 older patents would be considered by the district court); *Amazon.com, Inc., v. Audio Pod IP, LLC*, IPR2025-00757, Paper 15, 3 (Aug. 14, 2025) (inefficient use of Board resources to consider validity of one newer patent when validity of older patents would be considered by the district court).

The first of the patents related to the City Select stroller system—the '869 Patent—issued in 2015. Ex-1004. The application that led to the '682 Patent published in December 2020, and the '771 Patent application published in November 2022. Ex-1010, code (65); Ex-1011, code (65). Thus, Petitioner has also had constructive notice since then.

Despite over seven years of actual and constructive notice of the common parent patents covering aspects of Baby Jogger's widely praised and successful City Select strollers (Ex-2002), Petitioner made no challenge to the Patents. Baby

Jogger's settled expectations grew over the years, with no challenge to the Patent Office's allowance of multiple additional patents. Had Petitioner raised a challenge earlier, instead of watching Baby Jogger's patent family grow, any purported issues could have been addressed much earlier. As it is, Baby Jogger has gained settled expectations in its entire family, including the Patents issued in the last several years. And even after Baby Jogger served its infringement complaints on Petitioner on June 20, 2024 (*see* Ex-2007), Petitioner still waited until the last minute to file its Petitions on June 16 and 17, 2025—within days of the one-year bar. This factor favors discretionary denial. *See Ericsson Inc., et al. v. Procomm Int'l PTE. LTD.*, IPR2024-01455, Paper 15, 2 (May 16, 2025) (finding delay in filing petition negatively impacted timing of the final written decision with respect to the trial date).

Further, the products covered by the Patents—the City Select stroller system first introduced in 2009—have been commercially successful and recognized with innovation awards since at least 2010, including the Juvenile Products Manufacturers Association Innovation Award and National Parenting Publications Award (Ex-2002), and repeatedly recognized as patentable by the Office for 15 years. Further, Baby Jogger's patent marking began in early 2023, and the notoriety of the products, coupled with Petitioner's awareness of the growing Baby

Jogger portfolio, while it failed to challenge the Patents, means that Baby Jogger has strong settled expectations favoring discretionary denial.

B. Petitioner’s Extensive Reliance on Voluminous Expert Testimony Favors Denial

Petitioner relies extensively on expert argument and inferences to fill in the gaps of the prior art and to rationalize how that art could allegedly be modified or combined to arrive at the challenged claims. *Cf. iRhythm Techs., Inc. v. Welch Allyn, Inc.*, IPR2025-00363, Paper 10, 2-3 (June 6, 2025) (suggesting reliance on expert testimony to fill gaps in prior art weighs in favor of denial) (“*iRhythm*”). In effect, Petitioner uses sprawling, backward-looking declarations as a mouthpiece to relitigate the Examiner’s prior assessments of the art and patentability of the claims—despite the Examiner already considering one of same references in the 122 IPR and considering cumulative references teaching the same features in the 140 IPR.

Rather than offering focused declarations limited to points where expert input is indispensable, Petitioner cites their expert for *every* claim limitation and every ground—over 195 times in each Petition. *See generally* 122 IPR Pet. 32-126, 140 IPR Pet. 28-122. Petitioner also relies heavily on expert testimony for their priority arguments. *See* 122 IPR Pet. 20-24; 140 IPR Pet. 16-20.

The scale of the “expert” declarations is also striking. The two declarations relied on here total over 600 pages, each containing over 580 numbered paragraphs

and 38,000 words (140 IPR Ex-1001) to over 45,000 words (122 IPR Ex-1001), by Baby Jogger's estimate—approaching *triple* the word count permitted for petitions under 37 C.F.R. § 42.24. And the declarations here are similarly oversized to the Petitioner's declarations filed in its related IPRs challenging other patents in the family. *See, e.g.*, Patent Owner's Request for Discretionary Denial, IPR2025-01100, Paper 8, 10 (Sept. 2, 2025) (describing nearly 1000 pages of declarations and over 134,000 words across three declarations). This volume betrays Petitioner's strategy: evade the word limits, fill gaps in and rewrite the prior art, and bury the Board in expert testimony rather than rely on the art itself.

If this witness testimony were as essential as Petitioner implies, that fact alone counsels against institution. Live testimony subject to direct and cross-examination in a district court—on the stand in front of a judge or jury—is the superior forum. And district courts can better manage the scope and presentation of such evidence before a factfinder than can the Board. Here, institution would force the Board (and Baby Jogger) to parse through thousands of pages of declarations and transcripts.

Petitioner's overreliance on expert testimony—used to expand its attorney argument rather than aid the Board's understanding—weighs strongly in favor of denial.

C. The *Fintiv* Factors favor discretionary denial

Factor 1 concerns “whether a stay exists or is likely to be granted if a proceeding is instituted.” *Fintiv* at 6. Petitioner only recently moved for a stay pending the IPRs in the district court, filing its motion on September 5, 2025. But, the prospect of a stay being granted—especially before any decision on institution or on discretionary denial—is entirely speculative. Thus, this factor favors discretionary denial or is neutral. *Apple Inc. v. Fintiv, Inc.*, IPR2020-00019, Paper 15, 12 (May 13, 2020) (informative) (cautioning against speculating whether the district court will grant stay).

Factor 2 concerns “proximity of the court’s trial date to the Board’s projected statutory deadline for a final written decision.” *Fintiv* at 6. While a trial date has not been set in the parallel case, the median time to trial in the District of Delaware indicates the trial against Petitioner can be expected to begin around February 2027 (*see* Ex-2003). The expected statutory deadline for the Board’s Final Written Decisions is only a few months earlier, December 2026. With only two months between these dates, essentially all the parties’ investments would be duplicated, leading to significant inefficiencies. This factor is neutral.

Factor 3 considers the “investment in the parallel proceeding by the court and the parties.” *Fintiv* at 6. There is no scheduling order in the district court case yet, although to promote efficiency, Baby Jogger has requested the entry of an

order directing the parties to submit a proposed schedule. Absent a stay, the litigation will proceed, and substantial resources will be expended on discovery and motion practice. This factor is neutral.

Factor 4 concerns “overlap between issues raised in the petition and in the parallel proceeding.” *Fintiv* at 6. Regarding the district court litigation in Delaware, this factor is uncertain because Petitioner has not served invalidity contentions. Petitioner’s *Sotera* stipulation does *not* moot all invalidity arguments that could be raised in district court, so Petitioner will still have an opportunity to assert references relied on in the Petitions in combination with unpublished system art in district court.⁵ Petitioner’s *Sotera* stipulation falls short of ensuring that the IPR proceedings would be a “true alternative” to the district court prior art challenges. Petitioner would not be precluded from asserting combinations of art with unpublished systems in the district court. The Office’s Interim Discretionary Process website itself confirms that a *Sotera* stipulation under these circumstances is not “particularly meaningful” and there is only “limited” efficiency.⁶ *See also*

⁵ Petitioner’s co-Petitioner UPPAbaby in related IPR2025-01100, -01095, and -01120 has served invalidity arguments combining multiple IPR references, including one cited in the 122 Petition, with unpublished system art.

⁶ <https://www.uspto.gov/patents/ptab/interim-director-discretionary-process>.

Shenzen Tuozhu Tech. Co. v. Strataysys, Inc., IPR2025-00354, Paper 11, 2-3 (June 12, 2025) (*Sotera* stipulation “not likely to moot” district court invalidity arguments, so it may “reduce[], but does not eliminate, the inefficiencies” of parallel proceedings); *Motorola Sols. v. Stellar, LLC*, IPR2024-01205, Paper 19, 3-4 (Mar. 28, 2025) (same).

Petitioner filed its stipulations on August 1, 2025, well after the Director’s decision in *Tesla, Inc. v. Intellectual Ventures II, LLC*, IPR2025-00217, Paper 9 (June 13, 2025). Unlike a typical *Sotera* stipulation, Tesla’s “broad stipulation” had an additional provision in which it promised not to raise “any ground based on a combination of *system prior art* and the references asserted as part of a ground raised.” *Id.* at Paper 8, Ex-1067, 2-5. The Director stated that this counseled against discretionary denial. *Id.* at Paper 9 at 2. Thus, Petitioner was aware it could have filed stipulations that would have presented a “true alternative” but opted not to do so. Allowing the IPRs here to move forward will not remove the question of the validity of the Patents over system prior art in the district court, and, therefore, will not reduce the burdens on the parties to maintain two parallel proceedings. It would be an inefficient use of Board resources to address the challenged patents without being able to resolve them completely.

Factor 5: The Petitioner is the defendant in the parallel proceeding are the same, so this factor favors discretionary denial. *See Arashi Vision (U.S.) LLC d/b/a/ Insta360 v. GoPro, Inc.*, IPR2025-0017, Paper 11, 13–14 (Apr. 28, 2025).

Further, the issues discussed in Sections III.A-B above all bear on *Factor 6*, as they are other “relevant circumstances” considered as part of the “holistic analysis.”

D. Balancing all Factors Favors Denial

In sum, the § 314(a) considerations weigh strongly in favor of discretionary denial. The settled expectations of the Patent Owner in its family of Patents strongly favor discretionary denial. *See iRhythm* at 2 (the settled expectations factor “outweighs” the other considerations that weighed against denial). So does the overreliance on expert testimony. *Factors 2* and *3* also weigh in favor of exercising discretion or are neutral because of the proximity of the expected trial date and the final written decision and the current lack of a stay.

The Board’s resources are better spent allowing the district court to resolve the validity issues presented here, along with the many *other* patent issues it must address. Because the district court is poised to resolve all relevant disputes, the Board’s time and attention are better spent elsewhere.

IV. SECTION 325(d) FAVORS DISCRETIONARY DENIAL

The Petitions should also be denied institution because the same or substantially the same prior art or arguments were previously presented to the Office, and Petitioner did not even attempt to show material error.

The Office uses a two-pronged test to determine whether it will deny institution under 35 U.S.C. § 325(d): (1) whether the same or substantially the same art or arguments were previously presented; and (2) if so, whether the Office erred in a manner material to patentability. *Advanced Bionics, LLC v. MED-EL Elektromedizinische Geräte GmbH*, IPR2019-01469, Paper 6, 7-8 (Feb. 13, 2020) (precedential) (“*Advanced Bionics*”). Where a Petition challenges claims using art that was previously presented on an IDS, that alone “is sufficient to satisfy” the first prong of *Advanced Bionics*. *Ecto World, LLC v. RAI Strategic Holdings, Inc.*, IPR2024-01280, Paper 13, 4 (May 19, 2025) (precedential) (“*Ecto World*”).

Here, both prongs support discretionary denial. The 122 IPR contains two Grounds that rely on U.S. Patent D593,459 to Liao, but Liao was extensively considered and cited by the Patent Office during prosecution. For example, the Examiner rejected the pending claims over the combination of U.S. Patent 7,475,900 (Cheng) and Liao during prosecution of the application that issued as the ’682 Patent. Ex-1020 (Part 1) 335-345, 481-494; Ex-1020 (Part 2) 675-687. Although Petitioner asserts that “[t]he Examiner simply relied on Liao as teaching

a stroller which may comprise ‘at least one central wheel’” the record shows otherwise. The examiner expressly noted that Liao teaches “a similar stroller” to Cheng (122 IPR Pet. 27; Ex-1020 (Part 1) 341), and the parallels between the two are apparent from their drawings:

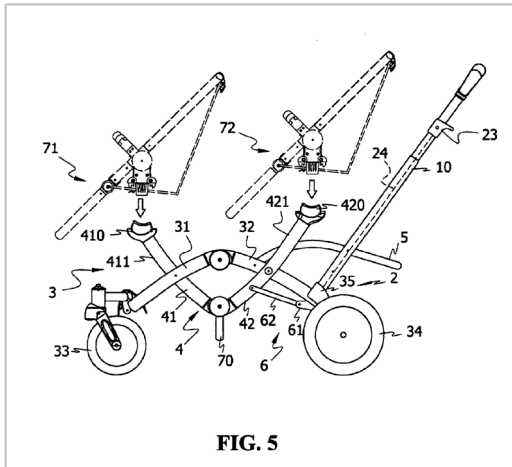

Cheng (Ex-1016)

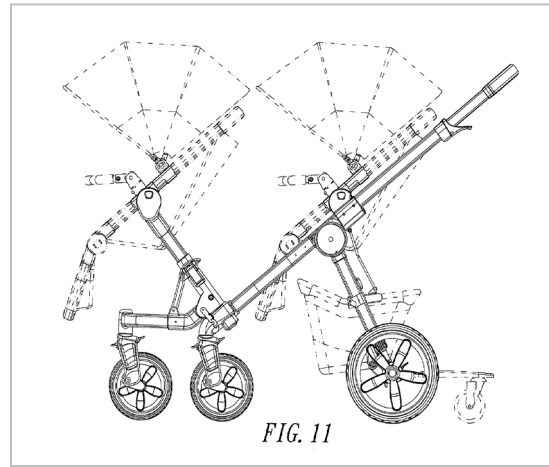

Liao (Ex-1048)

Moreover, this is not a complex or obscure field; the technology of baby strollers is straightforward and readily analyzed. The examiner cited both Cheng and Liao in three separate office actions, demonstrating that they were carefully considered. After that thorough review, the examiner nonetheless allowed the claims over both these references.

During prosecution of the application that issued as the '771 Patent, the applicant cited Liao on an IDS that the same Examiner considered. Ex-1021 (Part 1), 259. Liao was also relied on by this same Examiner during prosecution of several other applications that issued as members of this patent family, including

U.S. Patent Nos. 10,730,543; 11,192,568; 11,505,231; 11,878,729 and 12,275,449. Ex-1018, 535-554; Ex-1019 (Part 2), 557, Ex-1022 (Part 1), 255; Ex-1023, 25; Ex-1024 (Part 4), 1197-1208. Thus, *Advanced Bionics* step 1 is satisfied.

Under *Ecto World*, the petitioner bears the burden to explain, with reference to *Becton Dickinson* factors (c), (e), and (f), how the Examiner erred in overlooking the prior art—even as to art presented on an IDS. *Ecto World* at 5–6 (“[A] petitioner *must provide an analysis* even when the asserted prior art is on an IDS, but the Examiner did not apply the reference.” (emphasis added)). But the Petitions do not reference these factors at all, much less explain how the Examiner erred in a manner material to patentability to satisfy the second prong of *Advanced Bionics*. Petitioner’s failure here is inexcusable because the Petitions were filed after *Ecto World* was designated as precedential on May 19, 2025.

At best, the 122 IPR Petition makes only cursory allegations of error. *See* 122 IPR Pet. 28 (“the Examiner may not have appreciated these similarities during prosecution of the ’682 Patent.”), 29 (“The Examiner’s July 2024 rejection in the ‘417 Application, and the opinion from Petitioner’s experts, indicates an error occurred during prosecution ... in not fully considering and appreciating Liao’s disclosed design.”). These assertions merely second-guess the Examiner’s judgment without identifying any concrete error in the reasoning underlying allowance. Such conclusory statements cannot satisfy Petitioner’s burden to

demonstrate clear error, particularly where the Examiner repeatedly considered Cheng and Liao during prosecution and nonetheless allowed the claims.

Thus, 35 U.S.C. § 325(d) further supports discretionary denial of the Petitions.

V. CONCLUSION

For the reasons set forth above, and consistent with both *Fintiv* and the USPTO's updated guidance, the Board should exercise its discretion to deny institution under 35 U.S.C. § 314(a) or § 325(d).

Respectfully submitted,

/Warren Thomas/

Warren J. Thomas (Reg. No. 70,581)

CERTIFICATE OF SERVICE

Pursuant to 37 C.F.R. §§ 42.6(e) and agreement of the parties, I certify that on September 8, 2025, a copy of this paper and all accompanying exhibits were served on counsel for the Petitioner by email to:

John P. Rondini	jron dini@brookskushman.com
Frank A. Angileri	fangileri@brookskushman.com
Thomas W. Cunningham	tcunningham@brookskushman.com
Kyle G. Konz	kkonz@brookskushman.com
	GBBL0112IPR@brookskushman.com

/Meg Cogburn/
Meg Cogburn, Senior Paralegal
Meunier Carlin & Curfman LLC
999 Peachtree St, NE
Suite 1300
Atlanta, GA 30309