



(12) **United States Patent**  
**Kowalczyk et al.**

(10) **Patent No.:** **US 10,996,418 B2**  
(45) **Date of Patent:** **May 4, 2021**

(54) **CONNECTING SUBSCRIBERS TO A FIBER OPTIC NETWORK USING A CABLE SPOOL**

(58) **Field of Classification Search**  
CPC ..... G02B 6/46; G02B 6/445; G02B 6/4441;  
G02B 6/4457; G02B 6/4446;  
(Continued)

(71) Applicant: **CommScope Technologies LLC**,  
Hickory, NC (US)

(56) **References Cited**

(72) Inventors: **Scott C. Kowalczyk**, Savage, MN  
(US); **Jonathan Walter Coan**, Savage,  
MN (US); **Jonathan R. Kaml**,  
Shakopee, MN (US)

U.S. PATENT DOCUMENTS

1,276,825 A 8/1918 Swope  
1,442,999 A 1/1923 Boyle  
(Continued)

(73) Assignee: **CommScope Technologies LLC**,  
Hickory, NC (US)

FOREIGN PATENT DOCUMENTS

(\*) Notice: Subject to any disclaimer, the term of this  
patent is extended or adjusted under 35  
U.S.C. 154(b) by 0 days.

CN 1799296 A 7/2006  
DE 42 26 368 A1 2/1994  
(Continued)

(21) Appl. No.: **15/875,605**

OTHER PUBLICATIONS

(22) Filed: **Jan. 19, 2018**

7 Inch Modules, ADC Telecommunications, Inc., © 1998, "7 Inch  
Connector Module with IFC", pp. 127.

(65) **Prior Publication Data**

US 2018/0143390 A1 May 24, 2018

(Continued)

**Related U.S. Application Data**

*Primary Examiner* — Akm E Ullah

(74) *Attorney, Agent, or Firm* — Merchant & Gould P.C.

(63) Continuation of application No. 15/470,311, filed on  
Mar. 27, 2017, which is a continuation of application  
(Continued)

(57) **ABSTRACT**

An enclosure for connecting a subscriber to a fiber optic network includes a rotatable cable spool disposed within a main housing. A connectorized end of a subscriber cable is routed into the main housing and plugged into an adapter disposed within the enclosure. A cover of the enclosure is closed after the subscriber cable is plugged into the adapter. Prior to connecting the subscriber cable to the adapter, an optical cable can be paid out from the cable spool. One end of the optical cable rotates in unison with the cable spool while the other end is pulled from the enclosure.

(51) **Int. Cl.**  
**G02B 6/46** (2006.01)  
**G02B 6/44** (2006.01)  
**G02B 6/38** (2006.01)

**25 Claims, 14 Drawing Sheets**

(52) **U.S. Cl.**  
CPC ..... **G02B 6/4457** (2013.01); **G02B 6/3897**  
(2013.01); **G02B 6/445** (2013.01);  
(Continued)

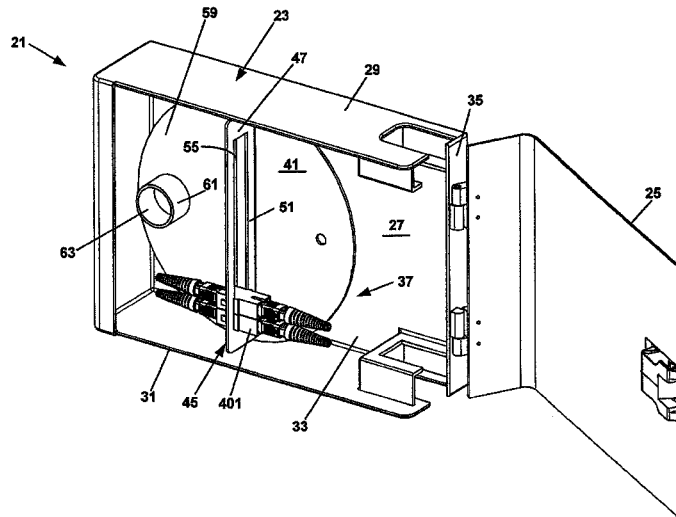

**Related U.S. Application Data**

No. 14/979,870, filed on Dec. 28, 2015, now Pat. No. 9,606,319, which is a continuation of application No. 14/539,459, filed on Nov. 12, 2014, now Pat. No. 9,261,666, which is a continuation of application No. 14/132,691, filed on Dec. 18, 2013, now Pat. No. 8,891,931, which is a continuation of application No. 13/924,191, filed on Jun. 21, 2013, now Pat. No. 8,705,929, which is a continuation of application No. 13/479,015, filed on May 23, 2012, now Pat. No. 8,494,333, which is a continuation of application No. 13/032,337, filed on Feb. 22, 2011, now Pat. No. 8,189,984, which is a continuation of application No. 12/793,556, filed on Jun. 3, 2010, now Pat. No. 7,894,701, which is a continuation of application No. 12/182,705, filed on Jul. 30, 2008, now Pat. No. 7,756,379.

(60) Provisional application No. 61/029,248, filed on Feb. 15, 2008, provisional application No. 60/954,214, filed on Aug. 6, 2007.

(52) **U.S. Cl.**  
 CPC ..... **G02B 6/441** (2013.01); **G02B 6/446** (2013.01); **G02B 6/4452** (2013.01); **G02B 6/4453** (2013.01); **G02B 6/4454** (2013.01); **G02B 6/4471** (2013.01); **G02B 6/46** (2013.01)

(58) **Field of Classification Search**  
 CPC .. G02B 6/4471; G02B 6/3897; G02B 6/4452; G02B 6/4453  
 USPC ..... 395/130-135  
 See application file for complete search history.

(56) **References Cited**

U.S. PATENT DOCUMENTS

1,446,410 A 2/1923 Bennett et al.  
 1,474,580 A 11/1923 Clark et al.  
 RE20,995 E 2/1939 Beasley  
 2,282,156 A 5/1942 Benes  
 2,502,496 A 4/1950 Wickman  
 2,521,226 A 9/1950 Keller  
 2,727,703 A 12/1955 Bonnett  
 2,767,426 A 10/1956 Grupp  
 3,131,729 A 5/1964 Leysinger  
 3,346,705 A 10/1967 Slinkard et al.  
 3,433,579 A 3/1969 Runnion  
 3,585,324 A 6/1971 Renndorfer et al.  
 3,612,424 A 10/1971 Friedel  
 3,657,491 A 4/1972 Ryder et al.  
 3,667,417 A 6/1972 Clinkenbeard  
 3,837,448 A 9/1974 Hagstrom  
 3,920,308 A 11/1975 Murray  
 3,940,086 A 2/1976 Stoqulet  
 3,983,977 A 10/1976 Crabb  
 4,053,118 A 10/1977 Aikins  
 4,081,258 A 3/1978 Goell et al.  
 4,138,177 A 2/1979 van Valer  
 4,143,746 A 3/1979 Lowery  
 4,201,278 A 5/1980 Balde  
 4,379,615 A 4/1983 Toda et al.  
 4,384,688 A 5/1983 Smith  
 4,470,558 A 9/1984 Stamper  
 4,520,239 A 5/1985 Schwartz  
 4,587,801 A 5/1986 Missout et al.  
 4,635,875 A 1/1987 Apple  
 4,657,140 A 4/1987 Zagar et al.  
 4,666,237 A 5/1987 Mallinson  
 4,767,073 A 8/1988 Malzacher  
 4,869,437 A 9/1989 Berz et al.  
 4,880,182 A 11/1989 Gelfman

4,883,337 A 11/1989 Dahlgren  
 4,913,369 A 4/1990 Lia et al.  
 4,939,798 A 7/1990 Last  
 4,940,859 A 7/1990 Peterson  
 4,953,194 A 8/1990 Hansen et al.  
 4,953,810 A 9/1990 Stadig  
 4,968,929 A 11/1990 Hauck et al.  
 4,978,310 A 12/1990 Shichida  
 4,989,582 A 2/1991 Sakiyama et al.  
 5,016,554 A 5/1991 Harris, Jr. et al.  
 5,052,940 A 10/1991 Bengal  
 5,066,149 A 11/1991 Wheeler et al.  
 5,066,256 A 11/1991 Ward, Sr.  
 5,069,523 A 12/1991 Finzel et al.  
 5,071,211 A 12/1991 Debortoli et al.  
 5,074,863 A 12/1991 Dines  
 5,100,221 A 3/1992 Carney et al.  
 5,107,532 A 4/1992 Hansen et al.  
 5,124,606 A \* 6/1992 Eisenbeis ..... H02K 17/30  
 112/277

5,161,988 A 11/1992 Krupka  
 5,166,970 A 11/1992 Ward  
 5,167,001 A 11/1992 Debortoli et al.  
 5,172,841 A 12/1992 Friedman  
 5,185,843 A 2/1993 Aberson et al.  
 5,222,164 A 6/1993 Bass, Sr. et al.  
 5,246,377 A 9/1993 Kawahara et al.  
 5,265,187 A 11/1993 Morin et al.  
 5,265,815 A 11/1993 Soyka et al.  
 5,280,861 A 1/1994 Corriveau  
 5,305,405 A 4/1994 Emmons et al.  
 5,310,356 A 5/1994 Obata et al.  
 5,317,663 A 5/1994 Beard et al.  
 5,326,040 A 7/1994 Kramer  
 5,335,874 A 8/1994 Shrum et al.  
 5,353,367 A 10/1994 Czosnowski et al.  
 5,393,249 A 2/1995 Morgenstern et al.  
 5,394,503 A 2/1995 Dietz, Jr. et al.  
 5,413,494 A 5/1995 Dewey et al.  
 5,418,334 A 5/1995 Williams  
 5,419,717 A 5/1995 Abendschein et al.  
 5,434,944 A 7/1995 Kerry et al.  
 5,448,015 A 9/1995 Jamet et al.  
 5,448,675 A 9/1995 Leone et al.  
 5,467,062 A 11/1995 Burroughs et al.  
 5,473,715 A 12/1995 Schofield et al.  
 5,483,467 A 1/1996 Krupka et al.  
 5,490,229 A 2/1996 Ghandeharizadeh et al.  
 5,494,234 A 2/1996 Kramer  
 5,494,446 A 2/1996 DeLucia et al.  
 5,497,444 A 3/1996 Wheeler  
 5,519,275 A 5/1996 Scott et al.  
 5,522,561 A 6/1996 Koyamatsu et al.  
 5,528,453 A 6/1996 Berman et al.  
 5,544,836 A 8/1996 Pera  
 5,551,545 A 9/1996 Gelfman  
 5,613,030 A 3/1997 Hoffer et al.  
 5,638,481 A 6/1997 Arnett  
 5,641,067 A 6/1997 Ellis  
 5,657,412 A 8/1997 Caudrelier  
 5,685,741 A 11/1997 Dewey et al.  
 5,703,990 A 12/1997 Robertson et al.  
 5,709,347 A 1/1998 Hoffmann et al.  
 5,712,942 A 1/1998 Jennings et al.  
 5,717,810 A 2/1998 Wheeler  
 5,718,397 A 2/1998 Stevens  
 5,733,141 A 3/1998 Penrod  
 5,734,774 A 3/1998 Morrell  
 5,749,148 A 5/1998 White, III et al.  
 5,773,757 A 6/1998 Kenney et al.  
 5,787,219 A 7/1998 Mueller et al.  
 5,821,510 A 10/1998 Cohen et al.  
 5,854,824 A 12/1998 Bengal et al.  
 5,915,640 A 6/1999 Wagter et al.  
 5,957,401 A 9/1999 O'Donnell  
 5,987,203 A 11/1999 Abel et al.  
 5,987,207 A 11/1999 Hoke  
 5,992,787 A 11/1999 Burke  
 6,002,331 A 12/1999 Laor

(56)

References Cited

U.S. PATENT DOCUMENTS

6,035,032	A	3/2000	Daoud		6,808,116	B1	10/2004	Eslambolchi et al.
6,077,108	A	6/2000	Lorscheider et al.		6,814,624	B2	11/2004	Clark et al.
6,095,837	A	8/2000	David et al.		6,834,517	B1	12/2004	Sheehy, Jr.
6,116,961	A	9/2000	Henneberger et al.		6,845,207	B2	1/2005	Schray
6,135,254	A	10/2000	Liao		6,850,685	B2	2/2005	Tinucci et al.
6,176,559	B1	1/2001	Tiramani et al.		6,856,748	B1	2/2005	Elkins, II et al.
6,195,494	B1*	2/2001	Abbott .....	G02B 6/3897 385/134	6,885,799	B2	4/2005	Lee
6,215,938	B1	4/2001	Reitmeier et al.		6,889,701	B2	5/2005	Kovacik et al.
6,220,413	B1*	4/2001	Walters .....	G02B 6/4457 191/12.4	6,898,368	B2	5/2005	Colombo et al.
6,220,762	B1	4/2001	Kanai et al.		6,901,200	B2	5/2005	Schray
6,222,908	B1	4/2001	Bartolutti et al.		6,905,363	B2	6/2005	Musolf et al.
6,222,975	B1	4/2001	Gilbert et al.		6,915,058	B2	7/2005	Pons
6,223,675	B1	5/2001	Watt et al.		6,926,130	B2	8/2005	Skowronski
6,234,830	B1	5/2001	Ensz et al.		6,932,517	B2	8/2005	Swayze et al.
6,238,235	B1	5/2001	Shavit et al.		6,933,441	B2	8/2005	Fuller et al.
6,243,526	B1	6/2001	Garibay et al.		6,937,725	B2	8/2005	Liao
6,285,293	B1	9/2001	German et al.		D510,068	S	9/2005	Haggay et al.
6,286,777	B1	9/2001	Black		6,944,387	B2	9/2005	Howell et al.
6,300,877	B1	10/2001	Schannach et al.		6,948,680	B2	9/2005	Ganster
6,315,598	B1	11/2001	Elliot et al.		6,961,675	B2	11/2005	David
6,330,148	B1	12/2001	Won et al.		6,971,895	B2	12/2005	Sago et al.
6,330,307	B1	12/2001	Bloch et al.		6,976,867	B2	12/2005	Navarro et al.
6,349,893	B1	2/2002	Daoud		6,997,410	B1	2/2006	Huang
6,350,148	B1	2/2002	Bartolutti et al.		7,000,863	B2	2/2006	Bethea et al.
6,361,360	B1	3/2002	Hwang et al.		7,011,538	B2	3/2006	Chang
6,367,347	B1	4/2002	Blaschke et al.		7,016,590	B2	3/2006	Tanaka et al.
6,419,175	B1	7/2002	Rankin, VI		7,017,721	B1	3/2006	Bradford et al.
6,421,322	B1	7/2002	Koziy et al.		7,027,704	B2	4/2006	Frohlich et al.
6,424,710	B1	7/2002	Bartolutti et al.		7,036,601	B2	5/2006	Berg et al.
6,427,045	B1*	7/2002	Matthes .....	G02B 6/445 385/134	7,050,041	B1	5/2006	Smith et al.
6,427,781	B1*	8/2002	Buhler .....	A01B 37/00 172/134	7,052,281	B1	5/2006	Meyberg et al.
6,433,274	B1	8/2002	Doss et al.		7,065,282	B2	6/2006	Sasaki et al.
6,442,240	B1	8/2002	Otto		7,077,710	B2	7/2006	Haggay et al.
6,456,768	B1	9/2002	Boncek et al.		7,081,808	B2	7/2006	Colombo et al.
6,456,773	B1	9/2002	Keys		7,112,090	B2	9/2006	Caveney et al.
D466,479	S	12/2002	Pein et al.		7,120,349	B2*	10/2006	Elliott .....
6,494,396	B2	12/2002	Sugata					G02B 6/4457 385/137
6,499,861	B1	12/2002	German et al.		7,123,810	B2	10/2006	Parrish
6,511,009	B1*	1/2003	Harrison .....	B65H 75/14 242/378.3	7,139,461	B2	11/2006	Puetz et al.
6,511,231	B2	1/2003	Lampert et al.		7,142,764	B2	11/2006	Allen et al.
6,522,737	B1	2/2003	Bartolutti et al.		7,153,142	B2	12/2006	Shifris et al.
6,522,826	B2	2/2003	Gregory		7,165,728	B2	1/2007	Durrant et al.
6,533,205	B1*	3/2003	Kles .....	B65H 54/58 242/362	7,190,767	B2	3/2007	Kracker et al.
6,533,216	B1	3/2003	Bumgarner et al.		7,193,422	B2	3/2007	Velleca et al.
6,554,221	B2	4/2003	Hinds		7,210,858	B2	5/2007	Sago et al.
6,554,484	B2	4/2003	Lampert		7,220,144	B1	5/2007	Elliott et al.
6,574,586	B1	6/2003	David et al.		7,226,217	B1	6/2007	Benton et al.
6,591,051	B2	7/2003	Solheid et al.		7,234,944	B2	6/2007	Nordin et al.
6,616,080	B1	9/2003	Edwards et al.		7,297,018	B2	11/2007	Caveney et al.
6,626,697	B1	9/2003	Martin et al.		7,306,101	B2	12/2007	Murry
6,631,237	B2	10/2003	Knudsen et al.		7,312,715	B2	12/2007	Shahs et al.
6,636,152	B2	10/2003	Schannach et al.		D559,186	S	1/2008	Kelmer
6,643,443	B2	11/2003	Holman et al.		7,315,224	B2	1/2008	Gurovich et al.
6,669,129	B1	12/2003	Shah		7,315,681	B2	1/2008	Kewitsch
6,684,179	B1	1/2004	David		7,346,253	B2	3/2008	Bloodsworth et al.
6,711,339	B2	3/2004	Puetz et al.		7,352,289	B1	4/2008	Harris
6,715,619	B2	4/2004	Kim et al.		7,364,108	B2	4/2008	Kim et al.
6,721,484	B1	4/2004	Blankenship et al.		7,369,739	B2	5/2008	Kline et al.
6,725,177	B2	4/2004	David et al.		7,370,106	B2	5/2008	Caveney
6,743,044	B2	6/2004	Musolf et al.		7,397,997	B2	7/2008	Ferris et al.
6,745,971	B1*	6/2004	Renzoni .....	B65H 75/362 242/388.1	7,399,198	B2	7/2008	Thalheimer et al.
6,758,314	B2	7/2004	Woodruff		7,400,814	B1	7/2008	Hendrickson et al.
6,760,530	B1	7/2004	Mandry		7,406,242	B1	7/2008	Braga
6,793,408	B2	9/2004	Levy et al.		7,477,829	B2	1/2009	Kaplan
6,795,633	B2	9/2004	Joseph, II		7,479,032	B2	1/2009	Hoath et al.
6,819,854	B1	9/2004	Young et al.		7,493,003	B2*	2/2009	Kowalczyk .....
6,802,735	B2	10/2004	Pepe et al.					G02B 6/4452 385/135
					7,519,000	B2	4/2009	Caveney et al.
					7,522,806	B2	4/2009	Hendrickson et al.
					7,533,841	B1	5/2009	Harrison et al.
					7,534,137	B2	5/2009	Caveney et al.
					7,546,018	B2	6/2009	Hendrickson et al.
					7,552,872	B2	6/2009	Tokita et al.
					7,570,861	B2	8/2009	Smrha et al.
					7,591,667	B2	9/2009	Gatnau Navarro et al.
					7,676,136	B2	3/2010	Wakileh et al.
					7,697,811	B2	4/2010	Murano et al.
					7,711,233	B2	5/2010	Mahoney
					7,715,679	B2	5/2010	Kowalczyk et al.

(56)		References Cited			
		U.S. PATENT DOCUMENTS			
7,751,672	B2	7/2010	Smith et al.	2004/0244430	A1
7,756,379	B2	7/2010	Kowalczyk et al.	2004/0258384	A1
7,809,234	B2	10/2010	Smith et al.	2005/0002633	A1
7,811,119	B2	10/2010	Caveney et al.	2005/0036587	A1
7,869,426	B2	1/2011	Hough et al.	2005/0062881	A1
7,869,682	B2	1/2011	Kowalczyk et al.	2005/0103515	A1*
7,872,738	B2	1/2011	Abbott		
7,885,505	B2	2/2011	Zimmel	2005/0128769	A1
7,894,701	B2	2/2011	Kowalczyk et al.	2005/0145522	A1
8,081,857	B2	12/2011	Nair et al.	2005/0184186	A1
8,131,126	B2	3/2012	Kowalczyk et al.	2005/0185910	A1
8,157,582	B2	4/2012	Frey et al.	2005/0213920	A1
8,189,984	B2	5/2012	Kowalczyk et al.	2005/0247136	A1
8,229,267	B2	7/2012	Kowalczyk et al.	2005/0258203	A1
8,254,740	B2	8/2012	Smith et al.	2005/0258411	A1
8,265,447	B2	9/2012	Loeffelholz et al.	2006/0006038	A1
8,326,107	B2	12/2012	Cooke et al.	2006/0028198	A1
8,380,035	B2	2/2013	Kowalczyk et al.	2006/0045458	A1*
8,422,847	B2	4/2013	Kowalczyk et al.		
8,428,419	B2*	4/2013	LeBlanc	2006/0054760	A1
			..... G02B 6/4441	2006/0126883	A1
			385/135	2006/0148279	A1
8,494,333	B2	7/2013	Kowalczyk et al.	2006/0153516	A1
8,494,334	B2	7/2013	Kowalczyk et al.	2006/0160395	A1
8,565,572	B2	10/2013	Krampotich et al.	2006/0163403	A1
8,705,929	B2	4/2014	Kowalczyk et al.	2006/0169856	A1
8,818,157	B2	8/2014	Burek et al.	2006/0183362	A1
RE45,153	E	9/2014	Hendrickson et al.	2006/0185953	A1
8,891,931	B2	11/2014	Kowalczyk et al.	2006/0186255	A1
8,929,706	B2	1/2015	Teymouri	2006/0187696	A1
8,938,147	B2	1/2015	Krampotich et al.	2006/0210230	A1*
9,170,392	B2	10/2015	Krampotich et al.		
9,223,103	B2	12/2015	Kachmar	2006/0231672	A1
9,261,663	B2	2/2016	Loeffelholz et al.	2006/0264094	A1
9,261,666	B2	2/2016	Kowalczyk et al.	2006/0266605	A1
9,310,578	B2	4/2016	Vastmans et al.	2006/0280418	A1
9,341,802	B2	5/2016	Krampotich et al.	2007/0023559	A1
9,429,728	B2	8/2016	Puetz et al.	2007/0025675	A1
9,453,971	B2	9/2016	Anderson et al.	2007/0036506	A1*
9,606,319	B2	3/2017	Kowalczyk et al.		
9,664,871	B1	5/2017	Galvan Mijangos et al.	2007/0096538	A1
9,684,142	B2	6/2017	Collart et al.	2007/0108333	A1
9,703,063	B2	7/2017	Van Baelen et al.	2007/0165995	A1
9,766,414	B2	9/2017	Marcouiller et al.	2007/0176045	A1
9,885,846	B2	2/2018	Kowalczyk et al.	2007/0189691	A1
9,995,898	B2	6/2018	Krampotich et al.	2007/0237470	A1
10,033,463	B2*	7/2018	Hubbard	2007/0237470	A1
RE47,307	E	3/2019	Allen	2008/0011990	A1
10,234,648	B2	3/2019	Kowalczyk et al.	2008/0013893	A1
2001/0019002	A1	9/2001	Walters et al.	2008/0013909	A1
2001/0048044	A1	12/2001	Sugata	2008/0035778	A1
2002/0003186	A1	1/2002	Hinds	2008/0037945	A1
2002/0023814	A1	2/2002	Poutiatine	2008/0093187	A1
2002/0023984	A1	2/2002	Oppmann et al.	2008/0100467	A1
2002/0083538	A1	7/2002	Silverman et al.	2008/0116312	A1
2002/0117571	A1	8/2002	Scott et al.	2008/0131132	A1*
2002/0125800	A1	9/2002	Knudsen et al.		
2002/0126980	A1	9/2002	Holman et al.	2008/0170831	A1
2002/0164121	A1	11/2002	Brennan, III et al.	2008/0011514	A1
2002/0171002	A1	11/2002	Krestsch et al.	2008/0199139	A1
2003/0000788	A1*	1/2003	Skowronski	2008/0218947	A1
			..... H01B 7/40	2008/0236209	A1
			191/12.2 R	2008/0292261	A1
2003/0037480	A1	2/2003	Davis	2008/0315030	A1
2003/0042348	A1	3/2003	Salentine et al.	2008/0315030	A1
2003/0142817	A1	7/2003	Liao	2009/0057085	A1
2003/0223724	A1*	12/2003	Puetz	2009/0060441	A1
			..... G02B 6/4452	2009/0074370	A1*
			385/135		
2003/0230667	A1	12/2003	Ganster	2009/0097846	A1
2004/0052498	A1	3/2004	Colombo et al.	2009/0098763	A1
2004/0065443	A1	4/2004	Berg et al.	2009/0166404	A1
2004/0084271	A1	5/2004	Woodruff	2009/0190894	A1
2004/0129522	A1	7/2004	Skowronski	2009/0215310	A1
2004/0170369	A1	9/2004	Pons	2009/0257726	A1
2004/0200332	A1	10/2004	Chen	2009/0317047	A1
2004/0209505	A1	10/2004	Wade et al.	2010/0054680	A1
2004/0240807	A1	12/2004	Frohlich et al.	2010/0054682	A1
				2010/0054684	A1
				2010/0074587	A1
				2010/0090830	A1
				12/2004	Sheehy, Jr.
				12/2004	Trebesch et al.
				1/2005	Solheid et al.
				2/2005	Kracker et al.
				3/2005	Caci et al.
				5/2005	Fuller
					..... G02B 6/4453
					174/50
				6/2005	Gozum et al.
				7/2005	Bloodworth et al.
				8/2005	Tsoi et al.
				8/2005	Zimmel
				9/2005	Tanaka et al.
				11/2005	Cross et al.
				11/2005	Weaver
				11/2005	Zeitler
				1/2006	Beverlin
				2/2006	Hoopengartner
				3/2006	Sasaki
					..... G02B 6/444
					385/135
				3/2006	Murry
				6/2006	Thalheimer et al.
				7/2006	German et al.
				7/2006	Napiorkowski et al.
				7/2006	Macauley et al.
				7/2006	Dickson
				8/2006	Dorenkamp et al.
				8/2006	Mullaney et al.
				8/2006	Gieseke
				8/2006	Rooker
				8/2006	Lanni
				9/2006	Kline
					..... G02B 6/4457
					385/135
				10/2006	Eastwood et al.
				11/2006	Young
				11/2006	Caamano et al.
				12/2006	Mahoney
				2/2007	Scapillato et al.
				2/2007	Kramer
				2/2007	Kewitsch
					..... G02B 6/4457
					385/135
				5/2007	Niemi et al.
				5/2007	Kuramoto
				7/2007	Reagan et al.
				8/2007	Chen
				8/2007	Barth et al.
				10/2007	Aronson et al.
				1/2008	Kostet et al.
				1/2008	Zheng et al.
				1/2008	Kostet et al.
				2/2008	Belden et al.
				2/2008	Gniadek et al.
				4/2008	Roberts et al.
				5/2008	Downie et al.
				5/2008	Eastwood et al.
				6/2008	Solheid
					..... G02B 6/4441
					398/117
				7/2008	Hendrickson et al.
				8/2008	Zheng et al.
				8/2008	Henderson
				9/2008	Atkinson
				10/2008	Conti et al.
				11/2008	Kowalczyk et al.
				12/2008	Hendrickson et al.
				3/2009	Caamano et al.
				3/2009	Kowalczyk et al.
				3/2009	Kowalczyk
					..... G02B 6/4441
					385/135
				4/2009	Kozischek et al.
				4/2009	Below et al.
				7/2009	German et al.
				7/2009	Nhep et al.
				8/2009	Hoath et al.
				10/2009	Redmann et al.
				12/2009	Smith et al.
				3/2010	Lochkovic et al.
				3/2010	Cooke
				3/2010	Cooke et al.
				3/2010	Loeffelholz et al.
				4/2010	Conti et al.

(56)

## References Cited

## U.S. PATENT DOCUMENTS

2010/0166376	A1	7/2010	Nair et al.	
2010/0211664	A1	8/2010	Raza et al.	
2010/0211665	A1	8/2010	Raza et al.	
2010/0211697	A1	8/2010	Raza et al.	
2010/0215049	A1	8/2010	Raza et al.	
2010/0322583	A1	12/2010	Cooke et al.	
2011/0044599	A1	2/2011	Kowalczyk et al.	
2011/0092100	A1	4/2011	Coffey et al.	
2011/0094274	A1	4/2011	Conti et al.	
2011/0103761	A1	5/2011	LeBlanc et al.	
2011/0158598	A1	6/2011	LeBlanc et al.	
2013/0094828	A1	4/2013	Loeffelholz et al.	
2013/0170810	A1	7/2013	Badar et al.	
2013/0170811	A1	7/2013	Kowalczyk et al.	
2013/0242866	A1	9/2013	Lin et al.	
2014/0010512	A1	1/2014	Kowalczyk et al.	
2014/0010513	A1	1/2014	Kowalczyk et al.	
2014/0219622	A1	8/2014	Coan et al.	
2015/0063770	A1	3/2015	Kowalczyk et al.	
2015/0093088	A1	4/2015	Matz et al.	
2017/0199344	A1	7/2017	Kowalczyk et al.	
2017/0235079	A1	8/2017	Kowalczyk et al.	
2018/0143386	A1*	5/2018	Coan .....	G02B 6/3897
2018/0299632	A1*	10/2018	Van Baelen .....	G02B 6/4466

## FOREIGN PATENT DOCUMENTS

DE	102 44 304	B3	3/2004
EP	1 107 031	A1	6/2001
EP	2 618 195	A2	7/2013
FR	2 566 997	A1	1/1986
GB	2 236 398	A	4/1991
JP	1-123203	A	5/1989
JP	9-236709		9/1997
JP	11-87006	A	3/1999
JP	11-349230		12/1999
JP	2003-114339		4/2003
JP	2005-73365		3/2005
JP	2005-249858		9/2005
JP	2007-121598		5/2007
JP	2007-121609		5/2007
WO	WO 2009/048680	A1	4/2009
WO	WO 2010/001400	A1	1/2010
WO	WO 2010/081186	A1	7/2010
WO	WO 2010/121639	A1	10/2010

## OTHER PUBLICATIONS

Answer, *CommScope Technologies LLC v. Clearfield, Inc.*, Case No. 0:17-cv-00307-PJS-BRT, 27 pages (Apr. 24, 2017).

Australian Examination Report for Application No. 2015205930; dated Jul. 13, 2016; 4 pages.

Australian Office Action (Appln. No. 2008247361), dated Nov. 8, 2013.

Avaya's Enhanced SYSTIMAX® iPatch System Enables IT Managers to Optimise Network Efficiency and Cut Downtime, Press Release, May 20, 2003, obtained from <http://www.avaya.com/usa/about-avaya/newsroom/news-releases/2003/pr-030520> on Jan. 7, 2009.

Complaint relating to Civil Action No. 5:11-cv-02509-JS, *ADC Telecommunications, Inc v. Opterna Am, Inc.* filed Apr. 11, 2011 (14 pages).

Complaint relating to Civil Action No. 1:11cv-735 (GBL-IDD), *ADC Telecommunications, Inc v. Opterna Am, Inc.* filed Jul. 12, 2011 (5 pages).

Complaint, *CommScope Technologies LLC v. Clearfield, Inc.*, Case No. 0:17-cv-00307, 77 pages (Jan. 31, 2017).

Complaint Exhibit G, *CommScope Technologies LLC v. Clearfield, Inc.*, Case No. 0:17-cv-00307-PJS-BRT, 3 pages (Jan. 31, 2017).

Complaint Exhibit H, *CommScope Technologies LLC v. Clearfield, Inc.*, Case No. 0:17-cv-00307-PJS-BRT, 3 pages (Jan. 31, 2017).

Defendant Clearfield Inc.'s Invalidity Claim Chart Exhibit 10, *CommScope Technologies LLC v. Clearfield, Inc.*, Case No. 0:17-cv-00307-PJS-BRT, 36 pages (Oct. 6, 2017).

Defendant Clearfield Inc.'s Invalidity Claim Chart Exhibit 11, *CommScope Technologies LLC v. Clearfield, Inc.*, Case No. 0:17-cv-00307-PJS-BRT, 60 pages (Oct. 6, 2017).

Defendant Clearfield Inc.'s Invalidity Claim Chart Table D, *CommScope Technologies LLC v. Clearfield, Inc.*, Case No. 0:17-cv-00307-PJS-BRT, 7 pages (Oct. 6, 2017).

Defendant Clearfield Inc.'s Invalidity Claim Chart Table E, *CommScope Technologies LLC v. Clearfield, Inc.*, Case No. 0:17-cv-00307-PJS-BRT, 7 pages (Oct. 6, 2017).

Defendant Clearfield Inc.'s Preliminary Invalidity Claim Charts and Disclosures, *CommScope Technologies LLC v. Clearfield, Inc.*, Case No. 0:17-cv-00307-PJS-BRT, 62 pages (Oct. 6, 2017).

Description of Admitted Prior Art, 30 pages.

European Office Action for Application No. 151182271.5-1504; dated Feb. 12, 2015, 7 pages.

European Search Report for Application No. 13163032.9 dated Jul. 4, 2013.

European Search Report for Application No. 15182271.5 dated Dec. 2, 2015.

F3DF Modules, ADC Telecommunications, Inc. © 1995, "Individual 12-Pack Assemblies", pp. 90.

Fiber Cable Management Products, Third Edition, ADC Telecommunications, Inc., © 1995, 1998.

Fiber Distribution Frame, Pre-Terminated Rear Load Connector Module, Installation Instructions, ADC Telecommunications, Inc., © 2000.

Fiber Main Distribution Frame (FMDF), Fiber Terminal Block, Installation Instructions, ADC Telecommunications, Inc., © 2001.

Fiber Panel Products—Cable Management Tray Panels, ADC Telecommunications, Inc., © 1994, 1996 "72 Fiber Distribution Module (FDM) with Intrafacility Fiber Cable", pp. 56.

Fiber Panel Products, Second Edition, ADC Telecommunications, Inc., © 1994, 1996.

FL2000 Products—Preconfigured Panels, ADC Telecommunications, Inc., © 2000 "Rack or Cabinet Mount Termination Panel with Multifiber Cable", pp. 13.

FL2000 Products, ADC Telecommunications, Inc., © 1994, 1996.

FL2000 Products, ADC Telecommunications, Inc., © 1994, 1996, "Rack Mount Panel with Intrafacility Fiber Cable", pp. 16.

IFC Style Frame Modules, ADC Telecommunications, Inc., © 1995, "Connector Module Equipped with IFC", pp. 27.

Intelligent patching systems carving out a 'large' niche, *Cabling Installation & Maintenance*, vol. 12, Issue 7, Jul. 2004 (5 pages).

intelliMAC: The intelligent way to make Moves, Adds or Changes! *NORDX/CDT* ©2003 (6 pages).

Petition for Inter Partes Review of U.S. Pat. No. 8,705,929, *Clearfield Inc. v. CommScope Technologies LLC*, Case No. IPR2017-02122, 67 pages (Sep. 15, 2017).

Inter Partes Review Case No. IPR2017-02122, Ex. 1003—Declaration of Dr. Michael Leiby, 141 pages (Sep. 15, 2017).

Inter Partes Review Case No. IPR2017-02122, Ex. 1004—U.S. Pat. No. 6,220,413 B1.

Inter Partes Review Case No. IPR2017-02122, Ex. 1005—U.S. Pat. No. 6,933,441 B2.

Inter Partes Review Case No. IPR2017-02122, Ex. 1006—U.S. Pat. No. 4,201,278.

Inter Partes Review Case No. IPR2017-02122, Ex. 1007—Prosecution History of U.S. Appl. No. 12/182,705, filed on Jul. 30, 2008., 332 pages.

Inter Partes Review Case No. IPR2017-02122, Ex. 1008—PCT Patent No. WO 2009/048680 A1.

Inter Partes Review Case No. IPR2017-02122, Ex. 1009—European U.S. Pat. No. 2 618 195 A2.

Inter Partes Review Case No. IPR2017-02122, Ex. 1010—EP App. No. 13163032.9.

Inter Partes Review Case No. IPR2017-02122, Ex. 1011—U.S. Pat. No. 4,657,140.

Inter Partes Review Case No. IPR2017-02122, Ex. 1012—USConec MTP® Brand Connectors Data Sheet (© 2014), 2 pages.

(56)

## References Cited

## OTHER PUBLICATIONS

Inter Partes Review Case No. IPR2017-02122, Ex. 1013—Katsuki Suematsu et al., “Super Low-Loss, Super High-Density Multi-Fiber Optical Connectors,” *Furukawa Review* (n. 23), 2003 (“Suematsu”).  
Inter Partes Review Case No. IPR2017-02122, Ex. 1014—U.S. Pat. No. 6,885,799 B2.

International Search Report and Written Opinion for PCT/US2008/062764 dated Aug. 8, 2008.

International Search Report and Written Opinion for PCT/US2008/075196 dated Nov. 18, 2008.

International Search Report and Written Opinion for PCT/US2008/072218 dated Mar. 18, 2009.

International Search Report and Written Opinion for PCT/US2010/052872 dated Jan. 12, 2011.

International Search Report and Written Opinion for PCT/US2011/041605 dated Feb. 24, 2012.

Meredith, L., “Managers missing point of intelligent patching,” *Daa Center News*, Jun. 21, 2005, obtained Dec. 2, 2008 from [http://searchdatacenter.techtarget.com/news/article/0,289142,sid80\\_gci1099991,00.html](http://searchdatacenter.techtarget.com/news/article/0,289142,sid80_gci1099991,00.html).

Next Generation Frame (NGF), Product Family Ordering Guide, ADC Telecommunications, Inc., © 1996, 1999, 2000, “Fiber Termination Blocks (FTB) Preterminated”, pp. 8.

Next Generation Frame (NGF), Product Family Ordering Guide, ADC Telecommunications, Inc., © 1996, 1999, 2000.

Next Generation Frames—Fiber Termination Blocks, ADC Telecommunication, Inc., © 1998, “Fiber Termination Blocks (FTB) Preterminated” pp. 6.

Notice of Allowance for application U.S. Appl. No. 13/924,191 dated Dec. 3, 2013.

Ohtsuki, F. et al., “Design of Optical Connectors with ID Modules,” *Electronics and Communications in Japan*, Part 1, vol. 77, No. 2, pp. 94-105 (Feb. 1994).

Plaintiff CommScope Technologies LLC’s Memorandum in Support of Motion to Compel Discovery, *CommScope Technologies LLC v. Clearfield, Inc.*, Case No. 0:17-cv-00307-PJS-BRT, 21 pages (Oct. 9, 2017).

Plaintiff CommScope Technologies LLC’s Response to Defendant’s First Set of Interrogatories to Plaintiff (Nos. 1-15), *CommScope Technologies LLC v. Clearfield, Inc.*, Case No. 0:17-cv-00307-PJS-BRT, 26 pages (Oct. 9, 2017).

Plaintiff CommScope Technologies LLC’s Supplemental Response to Defendant’s Interrogatory No. 2, *CommScope Technologies LLC v. Clearfield, Inc.*, Case No. 0:17-cv-00307-PJS-BRT, 5 pages (Oct. 9, 2017).

Plaintiff CommScope’s Initial Claim Charts including Exhibits J and K, *CommScope Technologies LLC v. Clearfield, Inc.*, Case No. 0:17-cv-00307-PJS-BRT, 28 pages (Oct. 9, 2017).

Plaintiff’s Notice of Dismissal relating to Civil Action No. 5:11-cv-02509-JS, *ADC Telecommunications, Inc v. Opterna Am, Inc.* filed Jul. 12, 2011 (1 page).

Supplemental Notice of Allowability for application U.S. Appl. No. 13/924,191 dated Mar. 10, 2014.

Supplemental Notice of Allowability for application U.S. Appl. No. 13/924,191 dated Mar. 14, 2014.

SYSTEMAX® iPatch System Wins Platinum Network of the Year Award, Press Release, Jan. 30, 2003, obtained from <http://www.avaya.com/usa/about-avaya/newsroom/news-releases/2003/pr-030130a> on Jan. 7, 2009.

TrueNet; TFP Series Rack Mount Fiber Panels, Spec Sheet; May 2008; 8 pages.

Value-Added Module System, ADC Telecommunications, Inc., © 1993, 1194, 1998, “12-Pack Module Assemblies”, pp. 30-31.

Preliminary Response by Patent Owner Under 37 C.F.R. § 42.107, Case IPR2017-02122, Paper No. 6, 71 pages. (Dec. 22, 2017).

Ex. 2001—Declaration of Casimer DeCusatis in Support of Patent Owner’s Preliminary Response, Case IPR2017-02122.

Ex. 2002—Office Action dated Jun. 19, 2009 in connection with U.S. Appl. No. 12/182,705.

Ex. 2003—Response to Jun. 19, 2009 Office Action in connection with U.S. Appl. No. 12/182,705.

Ex. 2004—U.S. Patent Application Publication No. 2006/021 0230 (“Kline”).

Ex. 2005—Excerpts from the Merriam-Webster’s Collegiate Dictionary (Tenth Edition) (2000).

Ex. 2006—Excerpts from the New Oxford American Dictionary (Third Edition) (2010).

Defendant Clearfield Inc.’s Revised Preliminary Invalidation Claim Charts and Disclosures, Civil Action No. 17-cv-00307-PJS-BRT, 51 pages (Dec. 11, 2017).

Defendant Clearfield Inc.’s Revised Invalidation Claim Chart Exhibit 10, *CommScope Technologies LLC v. Clearfield, Inc.*, Case No. 0:17-cv-00307-PJS-BRT, 38 pages (Dec. 11, 2017).

Defendant Clearfield Inc.’s Revised Invalidation Claim Chart Exhibit 11, *CommScope Technologies LLC v. Clearfield, Inc.*, Case No. 0:17-cv-00307-PJS-BRT, 39 pages (Dec. 11, 2017).

Defendant Clearfield Inc.’s Revised Invalidation Claim Table D, *CommScope Technologies LLC v. Clearfield, Inc.*, Case No. 0:17-cv-00307-PJS-BRT, 7 pages (Dec. 11, 2017).

Defendant Clearfield Inc.’s Revised Invalidation Claim Table E, *CommScope Technologies LLC v. Clearfield, Inc.*, Case No. 0:17-cv-00307-PJS-BRT, 6 pages (Dec. 11, 2017).

Defendant Clearfield Inc.’s Second Revised Preliminary Invalidation Claim Charts and Disclosures, Civil Action No. 17-cv-00307-PJS-BRT, 65 pages (Jan. 12, 2018).

Exhibit 10 to Second Revised Preliminary Invalidation Claim Charts and Disclosures, Civil Action No. 17-cv-00307-PJS-BRT, 43 pages (Jan. 12, 2018).

Exhibit 11 to Second Revised Preliminary Invalidation Claim Charts and Disclosures, Civil Action No. 17-cv-00307-PJS-BRT, 47 pages (Jan. 12, 2018).

CommScope’s Response to Clearfield’s Second Revised Invalidation Claim Charts and Disclosure, Civil Action No. 17-cv-00307-PJS-BRT, 105 pages (Jan. 19, 2018).

Exhibit J to Second Revised Preliminary Invalidation Claim Charts and Disclosures, Civil Action No. 17-cv-00307-PJS-BRT, 21 pages (Jan. 19, 2018).

Exhibit K to Second Revised Preliminary Invalidation Claim Charts and Disclosures, Civil Action No. 17-cv-00307-PJS-BRT, 19 pages (Jan. 19, 2018).

Joint Status Report, *CommScope Technologies LLC v. Clearfield, Inc.*, Case No. 0:17-cv-00307-PJS-BRT, 11 pages (Feb. 9, 2018).

Joint Status Report Exhibit A, *CommScope Technologies LLC v. Clearfield, Inc.*, Case No. 0:17-cv-00307-PJS-BRT, 33 pages (Feb. 9, 2018).

Joint Status Report Exhibit B, *CommScope Technologies LLC v. Clearfield, Inc.*, Case No. 0:17-cv-00307-PJS-BRT, 21 pages (Feb. 9, 2018).

Stipulation of Dismissal, *CommScope Technologies LLC v. Clearfield, Inc.*, Case No. 0:17-cv-00307-PJS-BRT, 2 pages (Feb. 19, 2018).

Order of Dismissal, *CommScope Technologies LLC v. Clearfield, Inc.*, Case No. 0:17-cv-00307-PJS-BRT, 1 page (Feb. 20, 2018).

\* cited by examiner

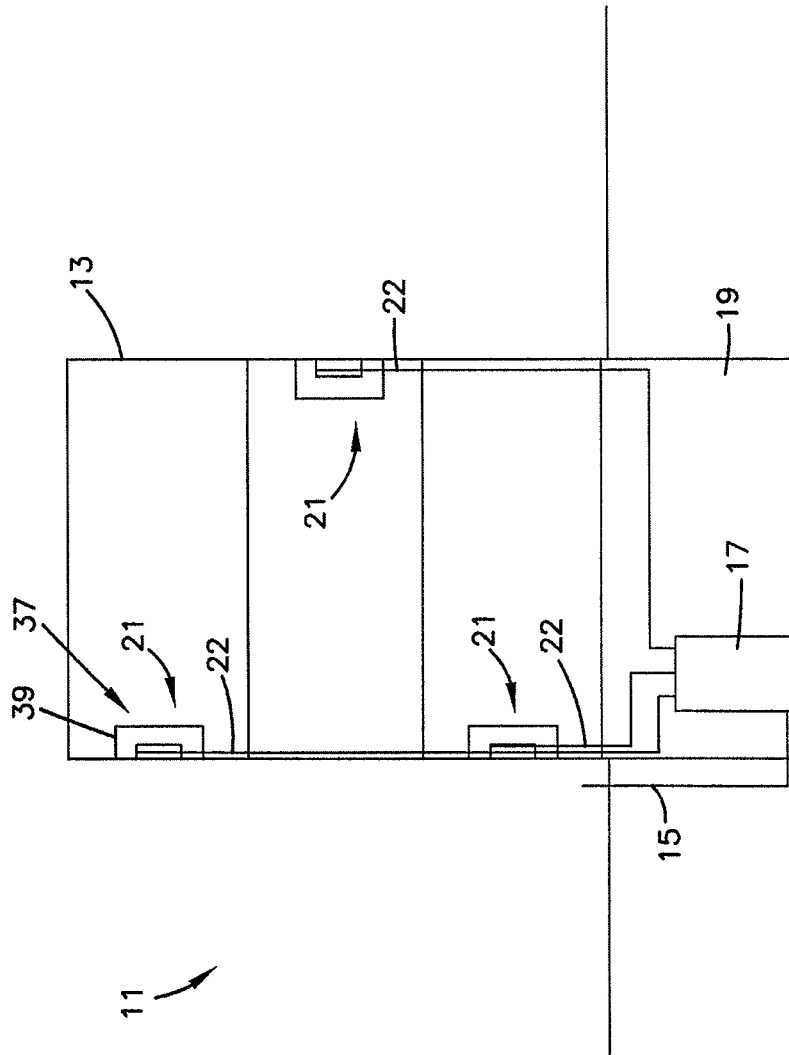

FIG. 1

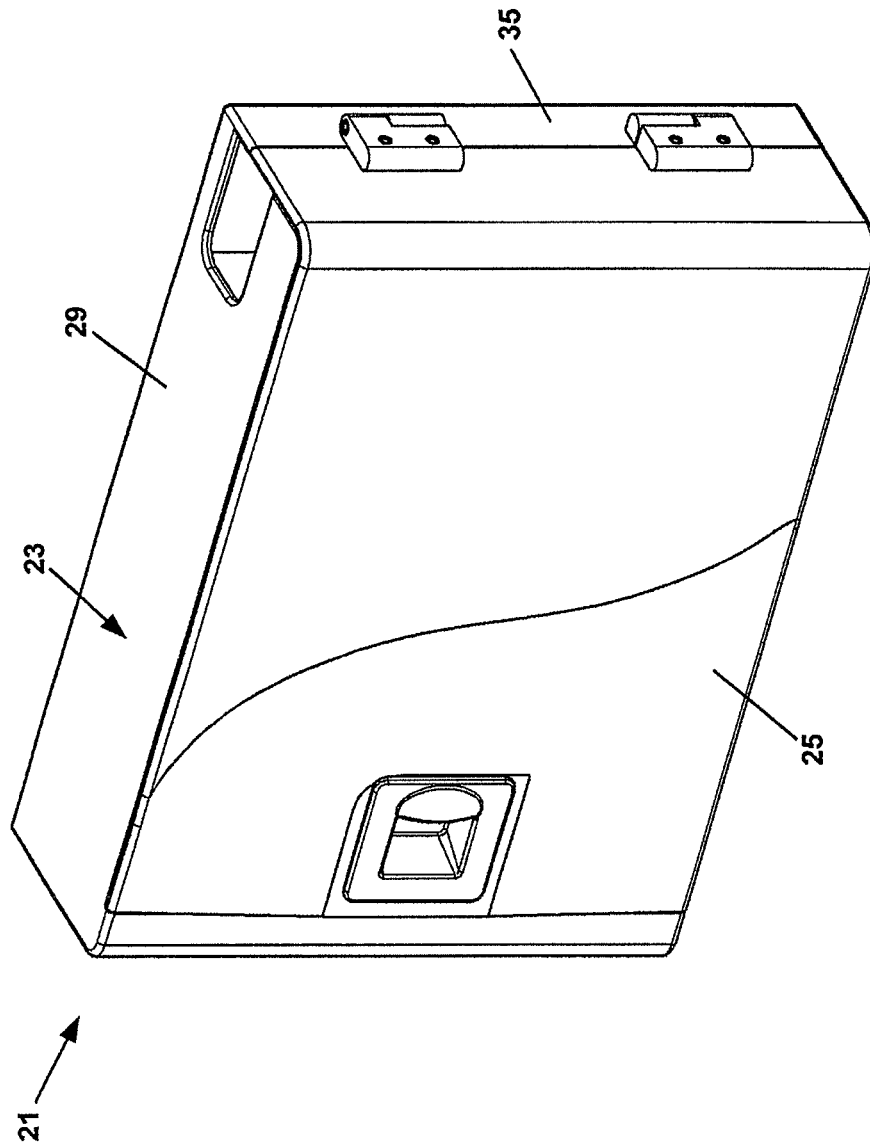

FIG. 2

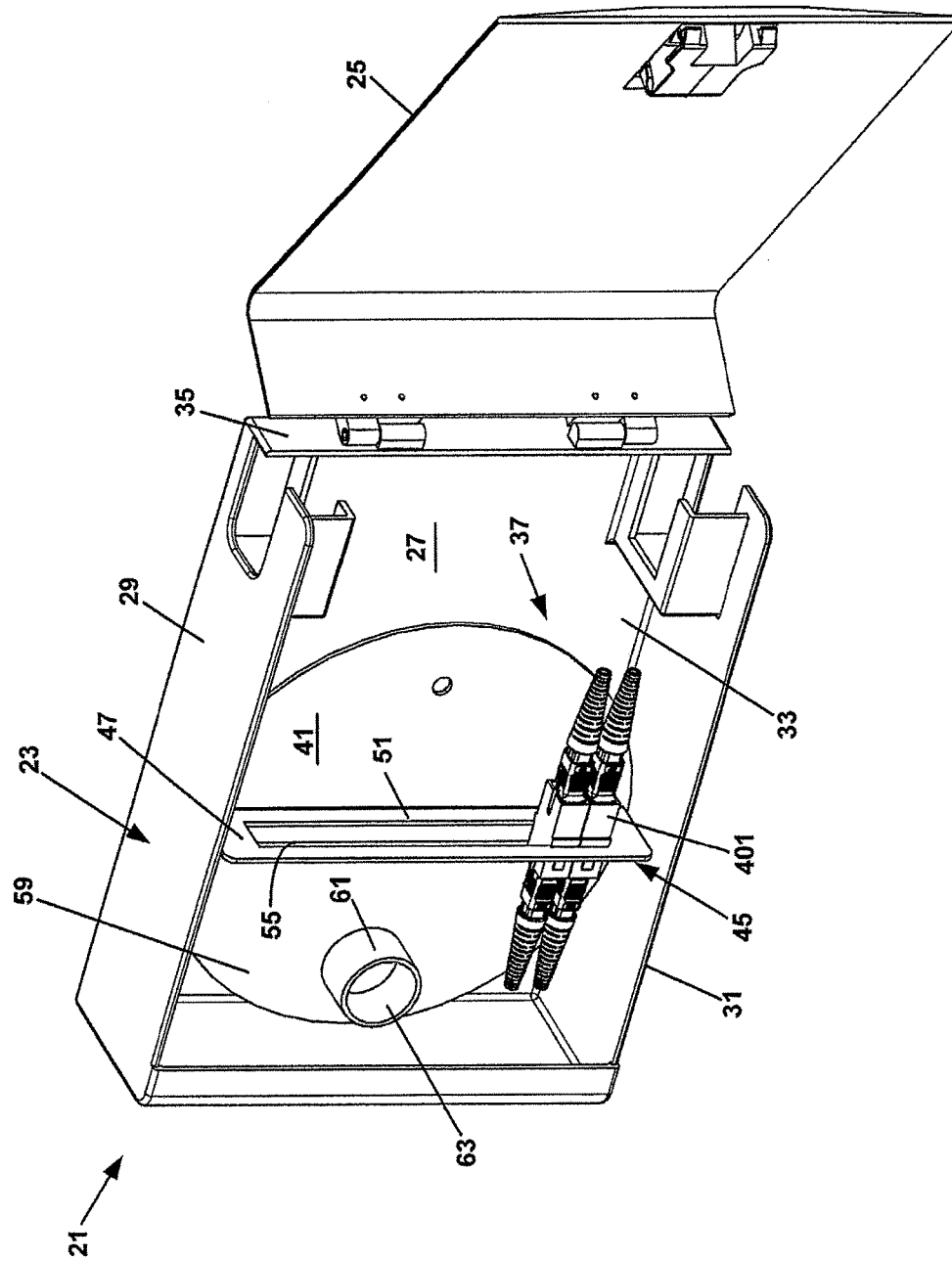
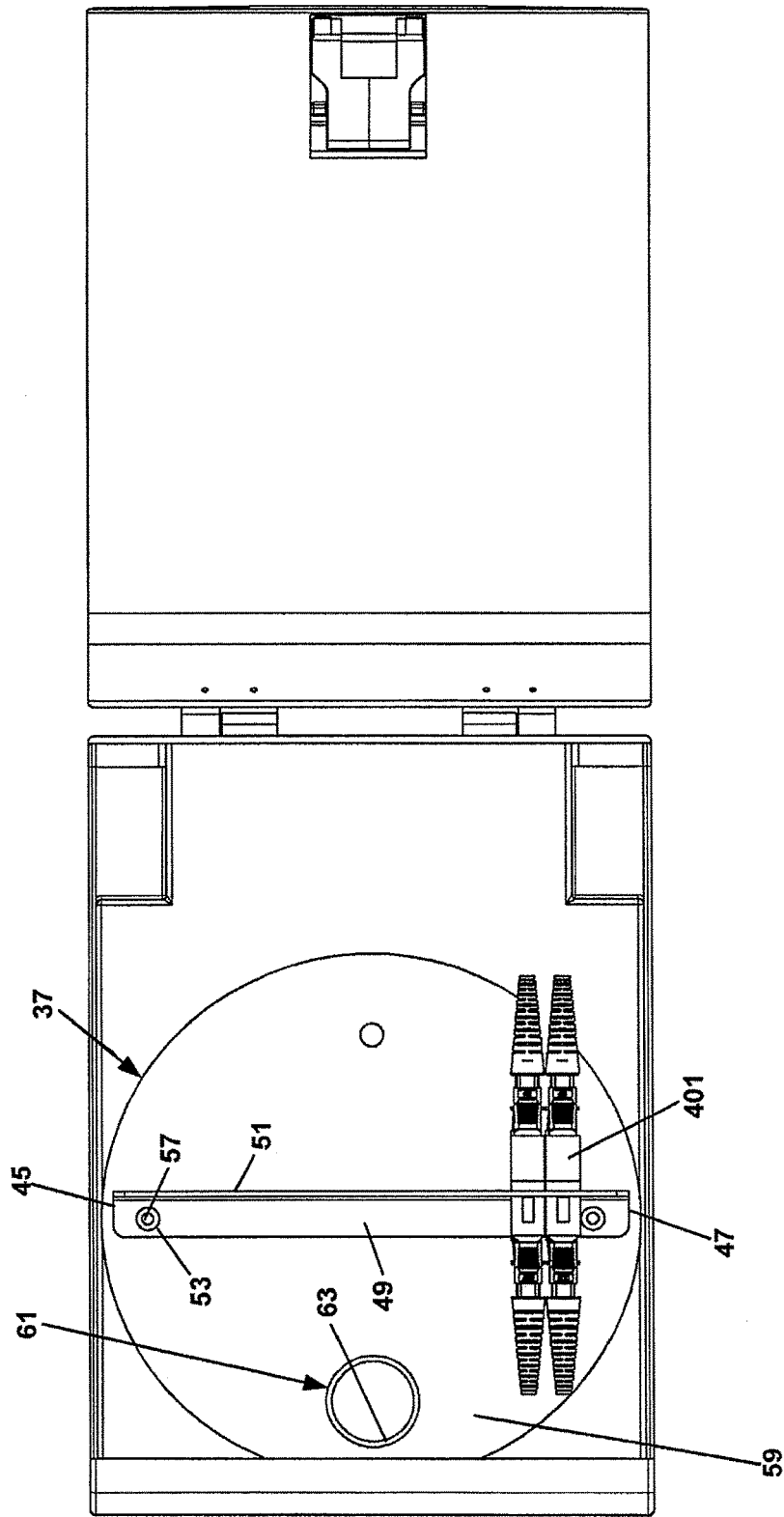

FIG. 3



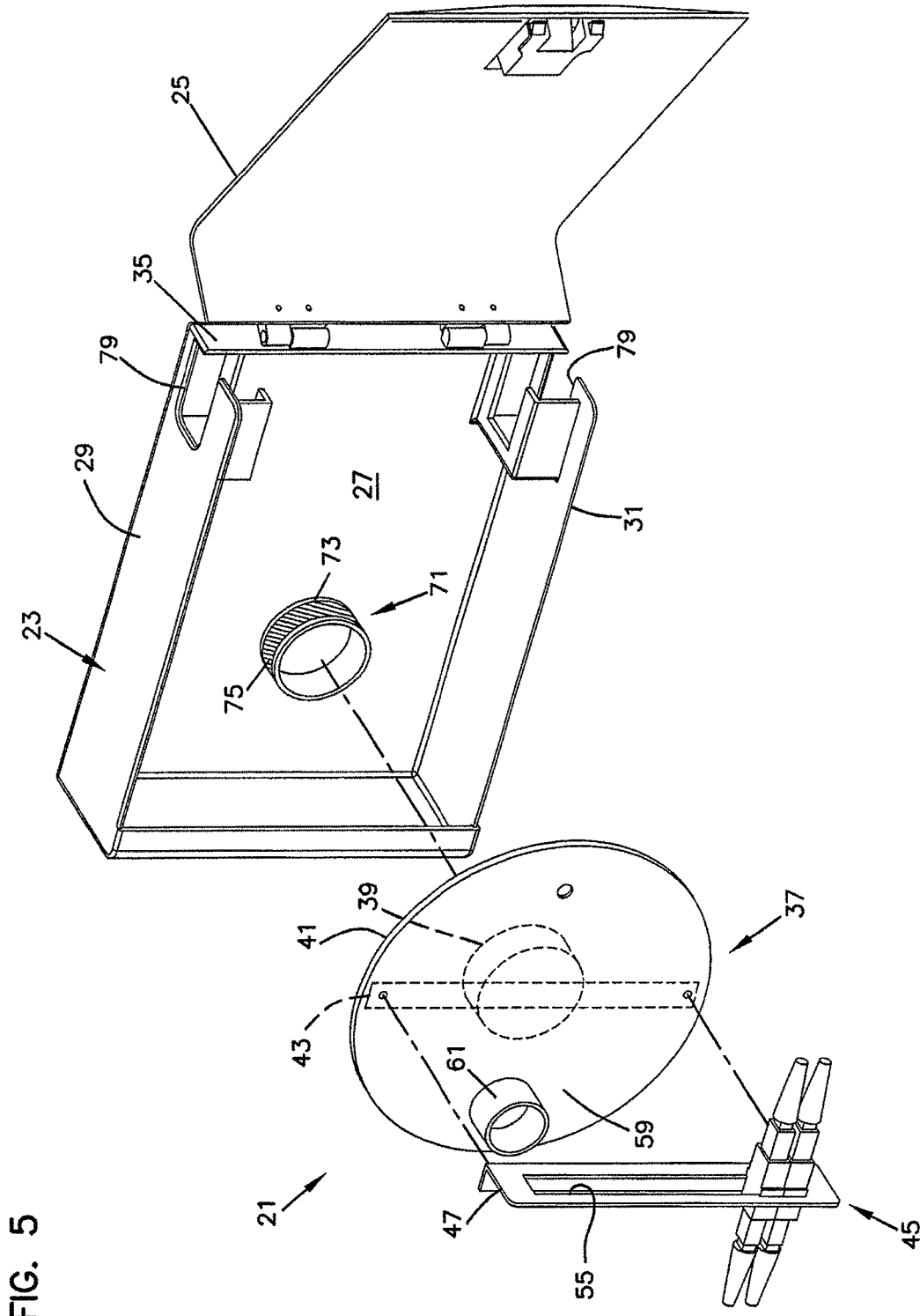

FIG. 5

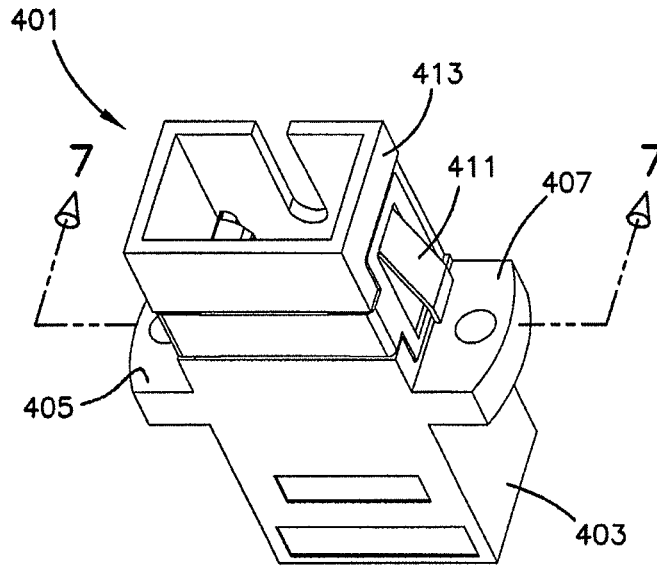

FIG. 6

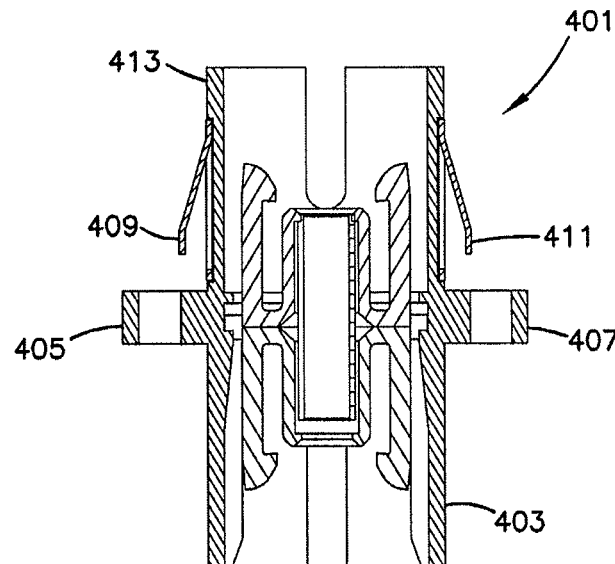

FIG. 7

FIG. 8

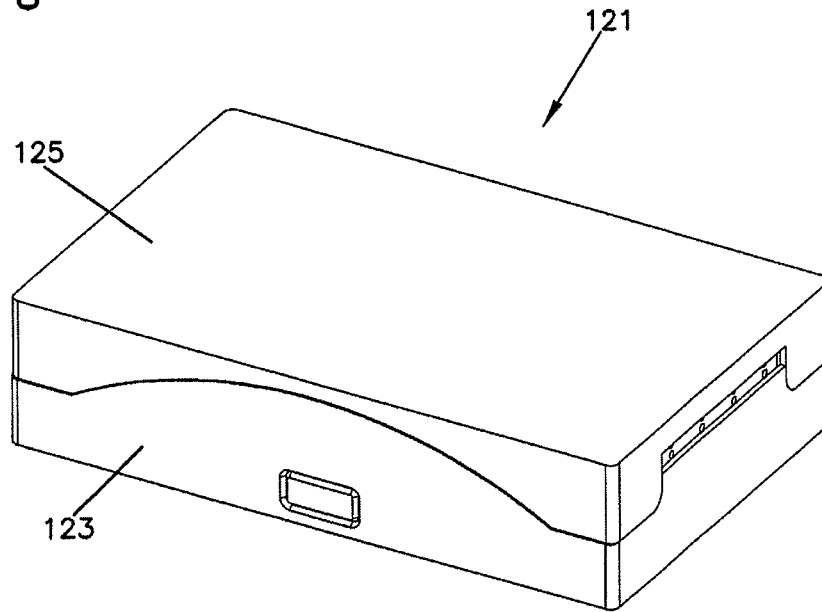

FIG. 9

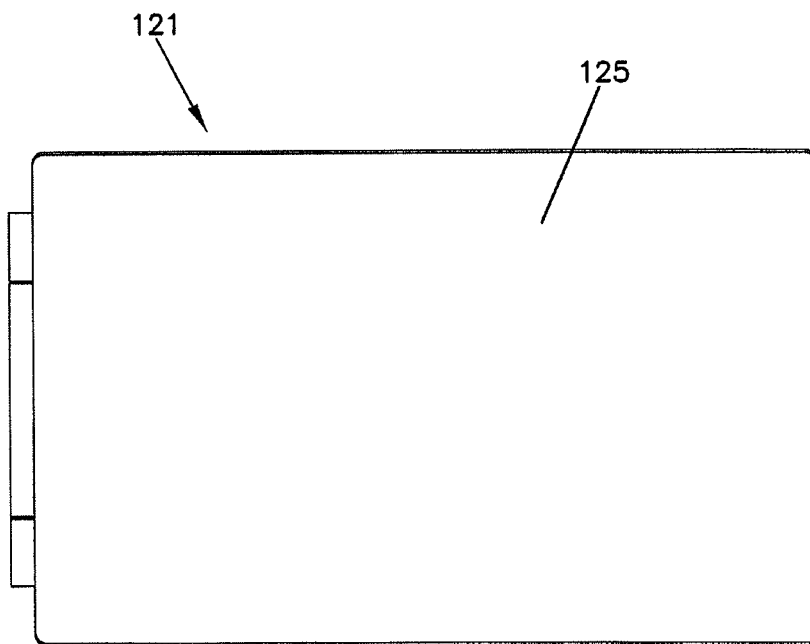

FIG. 10

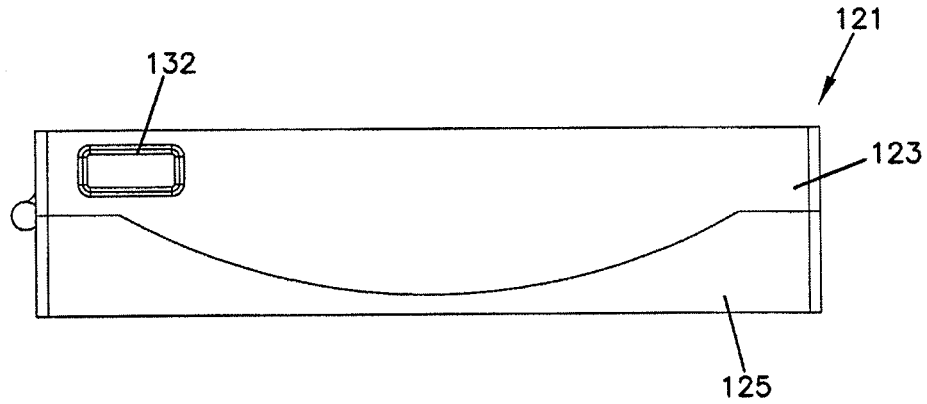

FIG. 11

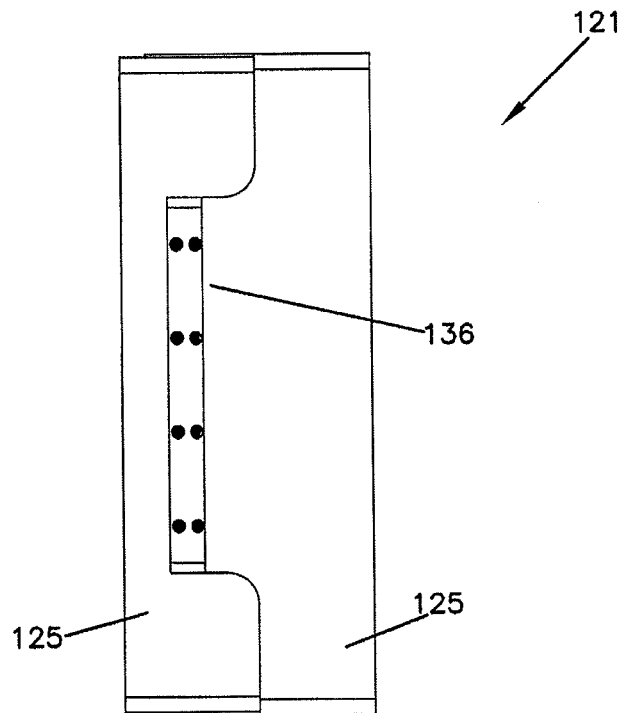

FIG. 12

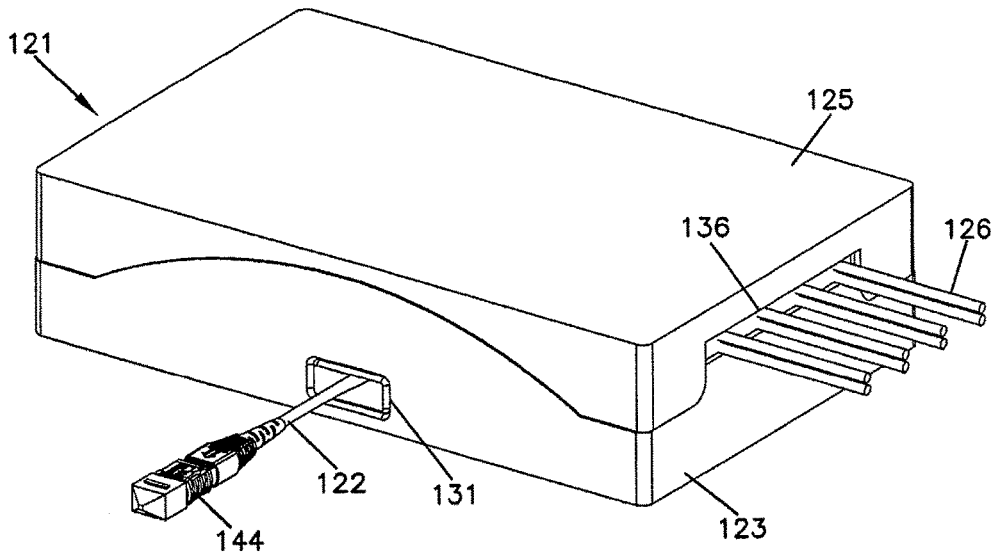
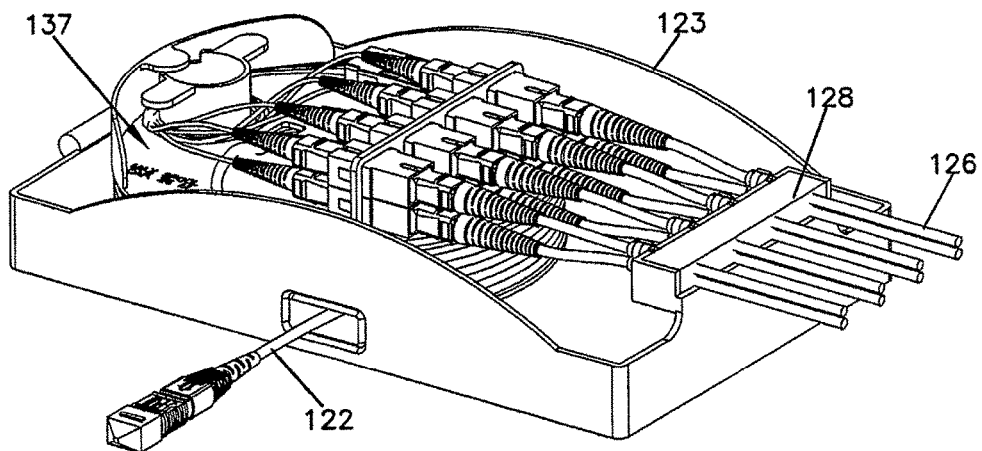

FIG. 13



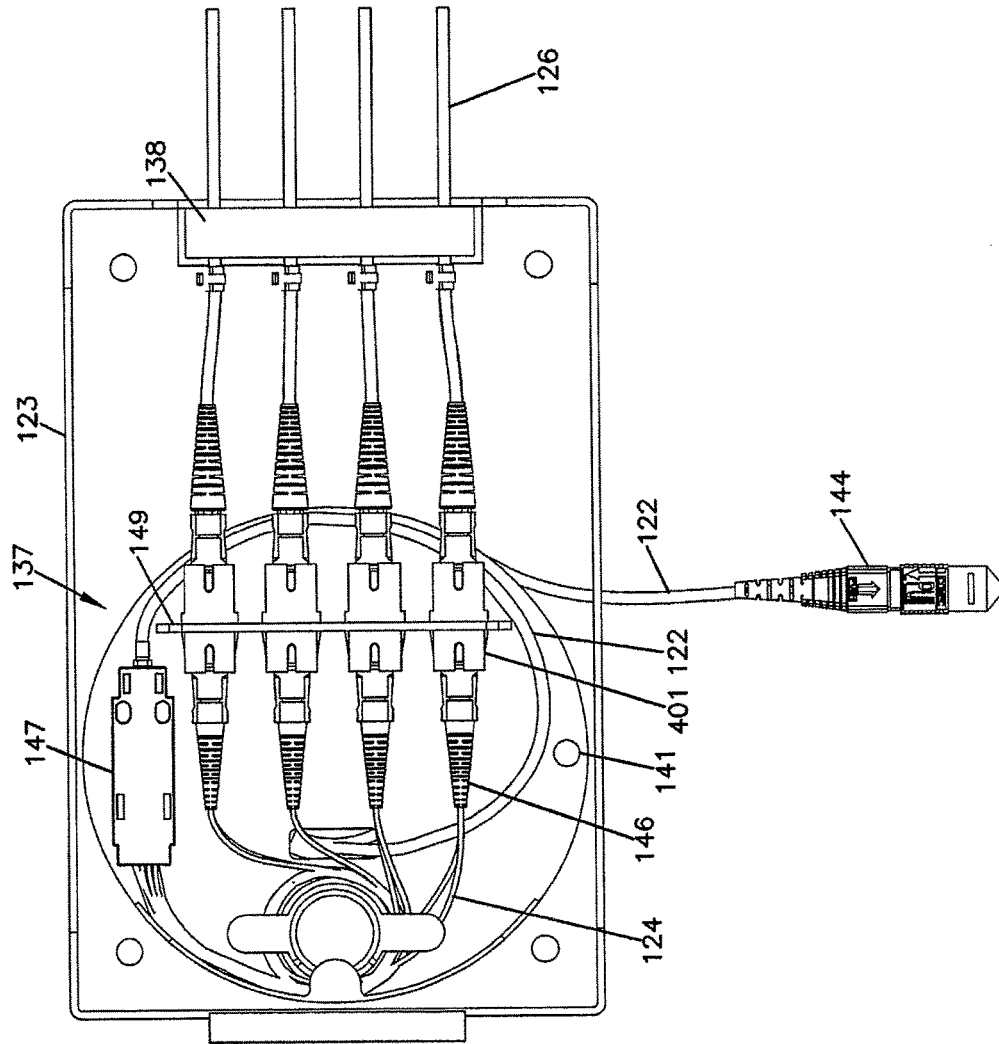

FIG. 14

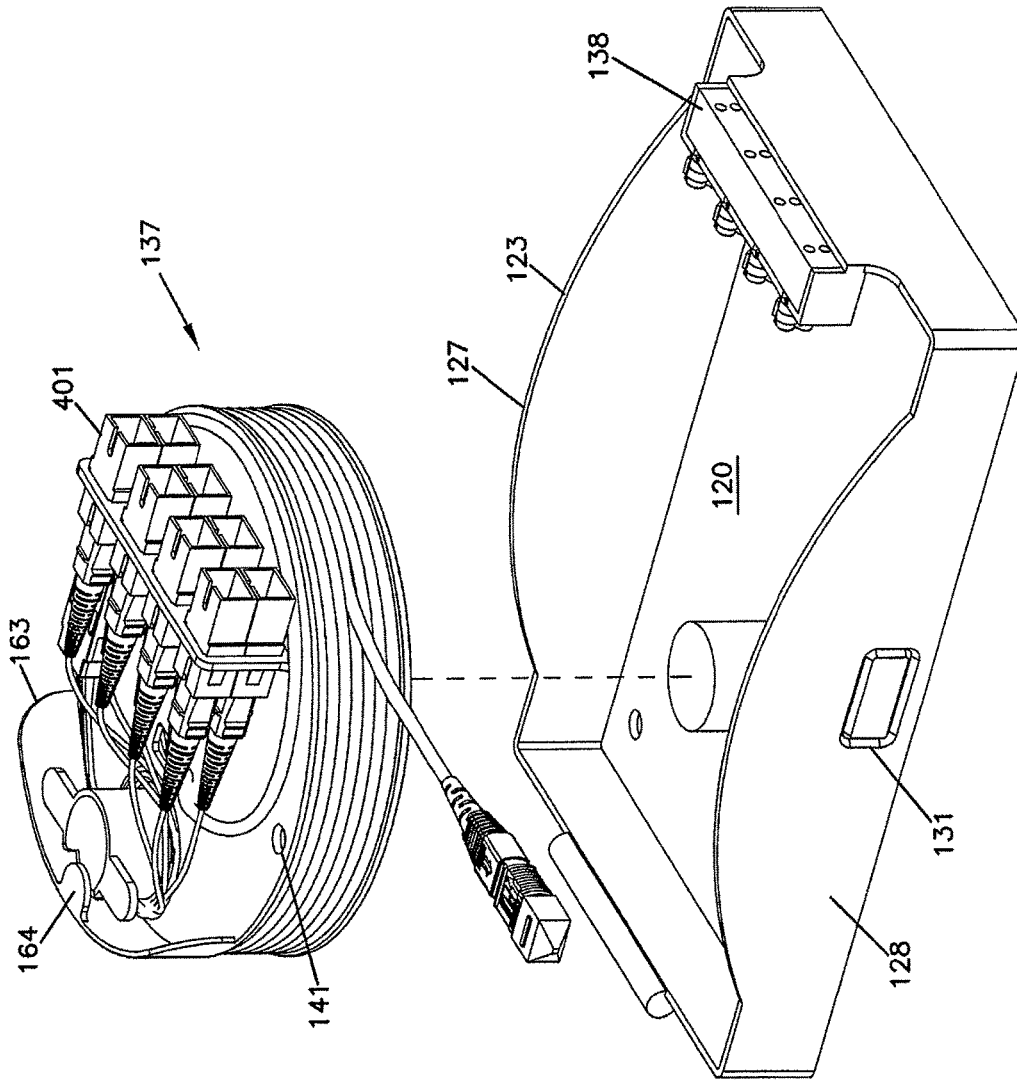

FIG. 15

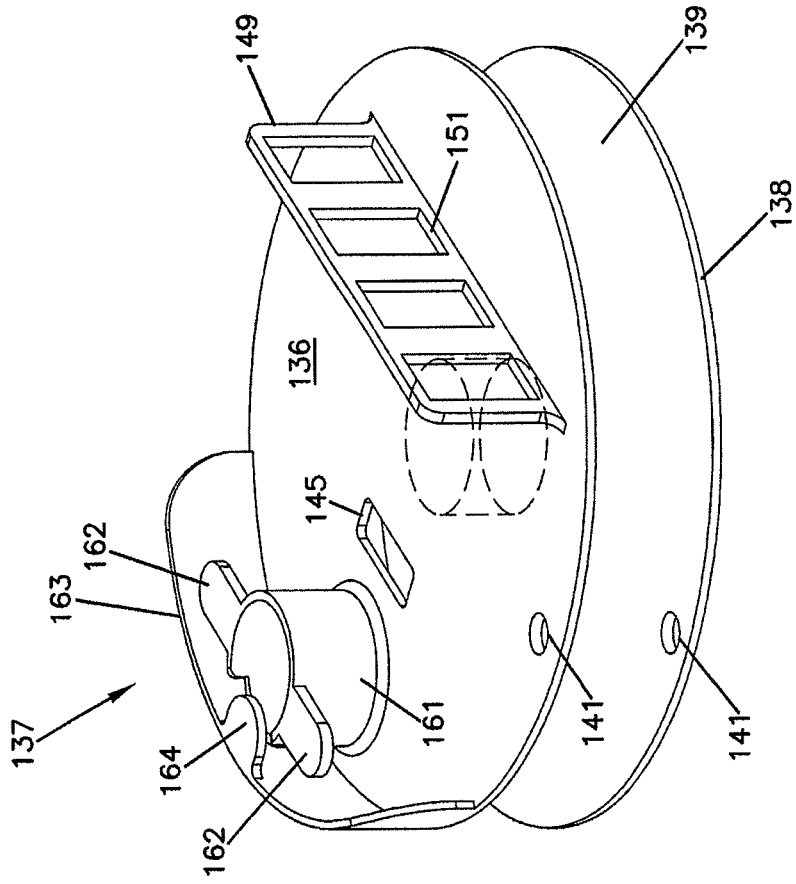

FIG. 16

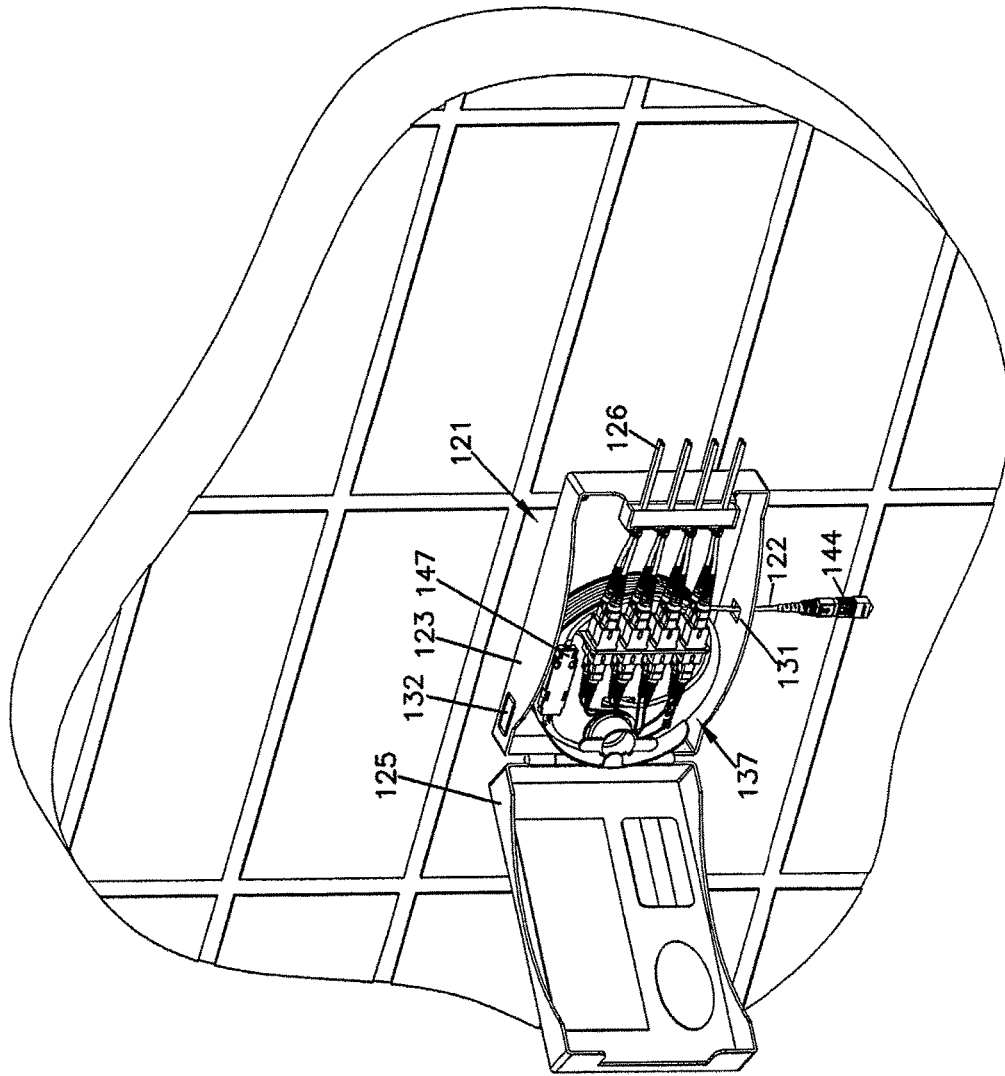
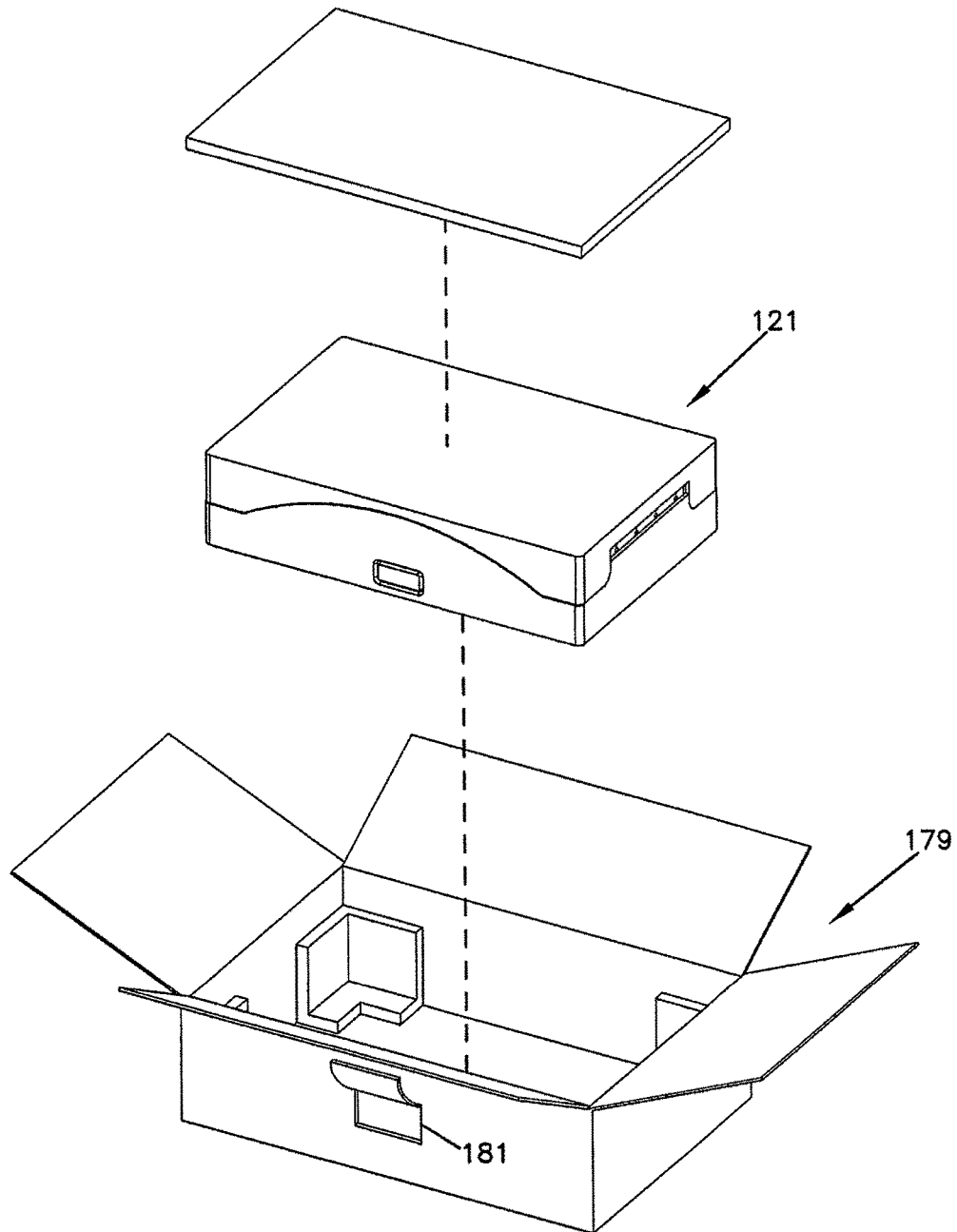

FIG. 17

FIG. 18



1

## CONNECTING SUBSCRIBERS TO A FIBER OPTIC NETWORK USING A CABLE SPOOL

### CROSS-REFERENCE TO RELATED APPLICATIONS

This application is a continuation of application Ser. No. 15/470,311, filed Mar. 27, 2017, now U.S. Pat. No. 10,712,518, which is a continuation of application Ser. No. 14/979,870, filed Dec. 28, 2015, now U.S. Pat. No. 9,606,319, which is a continuation of application Ser. No. 14/539,459, filed Nov. 12, 2014, now U.S. Pat. No. 9,261,666, which is a continuation of application Ser. No. 14/132,691, filed Dec. 18, 2013, now U.S. Pat. No. 8,891,931, which is a continuation of application Ser. No. 13/924,191, filed Jun. 21, 2013, now U.S. Pat. No. 8,705,929, which is a continuation of application Ser. No. 13/479,015, filed May 23, 2012, now U.S. Pat. No. 8,494,333, which is a continuation of application Ser. No. 13/032,337, filed Feb. 22, 2011, now U.S. Pat. No. 8,189,984, which is a continuation of application Ser. No. 12/793,556, filed Jun. 3, 2010, now U.S. Pat. No. 7,894,701, which is a continuation of application Ser. No. 12/182,705, filed Jul. 30, 2008, now U.S. Pat. No. 7,756,379, which application claims the benefit of provisional application Ser. Nos. 61/029,248, filed Feb. 15, 2008 and 60/954,214, filed Aug. 6, 2007, which applications are incorporated herein by reference in their entirety.

### TECHNICAL FIELD

The present disclosure relates to fiber optic enclosure, and more particularly, to a fiber optic enclosure with cable payout.

### BACKGROUND

As demand for telecommunications increases, fiber optic networks are being extended in more and more areas. In facilities such as multiple dwelling units, apartments, condominiums, businesses, etc., fiber optic enclosures are used to provide a subscriber access point to the fiber optic network. These fiber optic enclosures are connected to the fiber optic network through subscriber cables connected to a network hub. However, the length of subscriber cable needed between the fiber optic enclosure and the network hub varies depending upon the location of the fiber optic enclosure with respect to the network hub. As a result, there is a need for a fiber optic enclosure that can effectively manage varying lengths of subscriber cable.

### SUMMARY

An aspect of the present disclosure relates to a fiber optic enclosure assembly for enclosing optical fiber connections. The fiber optic enclosure assembly includes a housing having an interior region and a bearing mount disposed in the interior region of the housing. A cable spool is connectively engaged with the bearing mount such that the cable spool selectively rotates within the housing. A termination module is disposed on the cable spool so that the termination module rotates in unison with the cable spool.

Another aspect of the present disclosure relates to a method of paying out a fiber optic cable from a fiber optic enclosure. The method includes rotating a cable spool, which has a subscriber cable coiled around a spooling portion of the cable spool, about an axis of a housing of the fiber optic enclosure until a desired length of subscriber

2

cable is paid out. The cable spool is disposed in an interior region of the fiber optic enclosure and a termination module is disposed on the cable spool.

A variety of additional aspects will be set forth in the description that follows. These aspects can relate to individual features and to combinations of features. It is to be understood that both the foregoing general description and the following detailed description are exemplary and explanatory only and are not restrictive of the broad concepts upon which the embodiments disclosed herein are based.

### DESCRIPTION OF THE DRAWINGS

FIG. 1 is a schematic representation of a fiber optic network that includes a fiber optic enclosure having features that are examples of inventive aspects in accordance with the principles of the present disclosure.

FIG. 2 is an isometric view of the fiber optic enclosure of FIG. 1.

FIG. 3 is an isometric view of the fiber optic enclosure of FIG. 2 with a cover in an open position.

FIG. 4 is a front view of the fiber optic enclosure of FIG. 2 with the cover in the open position.

FIG. 5 is an exploded isometric view of the fiber optic enclosure of FIG. 2.

FIG. 6 is a perspective view of a fiber optic adapter suitable for use within the fiber optic enclosure of FIG. 2.

FIG. 7 is a cross-sectional view of the fiber optic adapter taken on line 7-7 of FIG. 6.

FIG. 8 is an isometric view of another embodiment of a fiber optic enclosure.

FIG. 9 is a front view of the fiber optic enclosure of FIG. 8.

FIG. 10 is a top view of the fiber optic enclosure of FIG. 8.

FIG. 11 is a side view of the fiber optic enclosure of FIG. 8.

FIG. 12 is an isometric view of the fiber optic enclosure of FIG. 8, showing cables entering and exiting the enclosure.

FIG. 13 is an isometric view of the fiber optic enclosure of FIG. 12 without the cover.

FIG. 14 is a front view of the fiber optic enclosure of FIG. 13.

FIG. 15 is an exploded isometric view of the fiber optic enclosure of FIG. 13.

FIG. 16 is an isometric view of the cable spool of the fiber optic enclosure of FIG. 13.

FIG. 17 is a further isometric view of the fiber optic enclosure of FIG. 12, with the cover in the pivoted open position.

FIG. 18 is an exploded view of a shipping container in which is disposed the fiber optic enclosure of FIG. 8.

### DETAILED DESCRIPTION

Reference will now be made in detail to the exemplary aspects of the present disclosure that are illustrated in the accompanying drawings. Wherever possible, the same reference numbers will be used throughout the drawings to refer to the same or like structure.

Referring now to FIG. 1, a schematic representation of a fiber optic network, generally designated 11, in a facility 13 (e.g. individual residence, apartment, condominium, business, etc.) is shown. The fiber optic network 11 includes a feeder cable 15 from a central office (not shown). The feeder cable 15 enters a feeder cable input location 17 (e.g., a fiber

3

distribution hub, a network interface device, etc.) having one or more optical splitters (e.g., 1-to-8 splitters, 1-to-16 splitters, or 1-to-32 splitters) that generate a number of individual fibers. In the subject embodiment, and by way of example only, the fiber distribution hub 17 is located on a lower level 19 of the facility 13. Each unit in the facility 13 includes a fiber optic enclosure, generally designated 21, with a subscriber cable 22 extending from each of the fiber optic enclosures 21 to the fiber distribution hub 17. The subscriber cable 22 extending between the fiber distribution hub 17 and the fiber optic enclosure 21 typically includes multiple optical fibers.

Referring now to FIGS. 2-5, the fiber optic enclosure 21 will now be described. The fiber optic enclosure 21 includes a housing, generally designated 23, having a cover 25.

The housing 23 includes a base 27, a first sidewall 29, and an oppositely disposed second sidewall 31. The first and second sidewalls 29, 31 extend outwardly from the base 27 such that the base 27 and the first and second sidewalls 29, 31 cooperatively define an interior region 33. In the subject embodiment, the cover 25 is hingedly engaged with a sidewall 35 that is connected to the base 27 and the first and second sidewalls 29, 31. It will be understood, however, that the scope of the present disclosure is not limited to the cover 25 being hingedly engaged the sidewall 35.

A cable spool, generally designated 37, is disposed in the interior region 33 of the fiber optic enclosure 21. The cable spool 37 includes a spooling portion 39, around which subscriber cable 22 is coiled (shown schematically in FIG. 1). The cable spool 37 further includes an axial end 41.

In the subject embodiment, the axial end 41 of the cable spool 37 defines a termination area 43 (shown as a dashed line in FIG. 5). Disposed in the termination area 43 is a termination module, generally designated 45. The termination module 45 of the fiber optic enclosure 21 serves as the dividing line between the incoming fibers and the outgoing fibers.

In the subject embodiment, the termination module 45 includes an adapter plate 47. The adapter plate 47 is an L-shaped bracket having a first side 49 (shown in FIG. 4) and a second side 51. The first side 49 defines a plurality of mounting holes 53 while the second side 51 defines an adapter slot 55. It will be understood, however, that the scope of the present disclosure is not limited to the adapter plate 47 being an L-shaped bracket. The first side 49 of the adapter plate 47 is rigidly mounted (i.e., non-rotatable) to the axial end 41 of the cable spool 37 through a plurality of fasteners 57 (e.g., bolts, screws, rivets, etc.) which are inserted through the mounting holes 53 in the first side 49 and in connected engagement with the axial end 41 of the cable spool 37.

The adapter slot 55 in the second side 51 of the adapter plate 47 is adapted to receive a plurality of adapters, generally designated 401. In the subject embodiment, the adapters 401 are SC-type adapters 401, although it will be understood that the scope of the present disclosure is not limited to the use of SC-type adapters 401. Similar SC-type adapters 401 have been described in detail in commonly owned U.S. Pat. No. 5,317,663, the disclosure of which is incorporated herein by reference.

Referring now to FIGS. 6 and 7, the SC-type adapter 401 includes a main body 403 with a pair of tabs 405, 407 located on the exterior of the main body 403. The tabs 405, 407 serve to support the adapter 401 in the adapter slot 55. The adapter 401 further includes a pair of retaining clips 409, 411, with one retaining clip 409, 411 associated with each tab 405, 407. A front side 413 of the adapter 401 is

4

inserted into the adapter slot 55. As the adapter 401 is inserted through the adapter slot 55, the retaining clips 409, 411 compress against the main body 403. The adapter 401 is inserted into the adapter slot 55 until the tabs 405, 407 abut the adapter plate 47. With the tabs 405, 407 abutting the adapter plate 47, the retaining clips 409, 411 decompress on the opposite side of the adapter plate 47, thereby retaining the adapter plate 47 between the retaining clips 409, 411 and the tabs 405, 407.

In an alternate embodiment, the termination module includes a plurality of sliding adapter modules. Similar sliding adapter modules have been described in detail in commonly owned U.S. Pat. Nos. 5,497,444; 5,717,810, 6,591,051 and U.S. Pat. Pub. No. 2007/0025675, the disclosures of which are incorporated herein by reference.

Referring now to FIGS. 3-5, the axial end 41 of the cable spool 37 further defines a slack storage area 59. The slack storage area 59 includes a cable management spool 61 disposed on the axial end 41 of the cable spool 37. The cable management spool 61 is sized such that an outer radius of the cable management spool 61 is larger than the minimum bend radius of the optical fibers so as to avoid attenuation damage to the optical fibers during storage.

The cable management spool 61 and the axial end 41 of the cable spool 37 cooperatively define a cable passage 63 that extends axially through the cable management spool 61 and through the axial end 41 of the cable spool 37. The cable passage 63 allows connectorized ends of incoming optical fibers to pass from the spooling portion 39 of the cable spool 37 to the slack storage area 59. The connectorized ends of the incoming optical fibers are then routed from the slack storage area 59 to the front sides 413 of the adapters 401 in the termination area 43.

Referring now to FIG. 5, the fiber optic enclosure 21 further includes a bearing mount, generally designated 71. In the subject embodiment, the bearing mount 71 is disposed on the base 27 of the housing 23. An outer surface 73 of the bearing mount 71 is adapted for a bearing 75 (shown as cross-hatching). In the subject embodiment, the bearing 75 is a needle bearing. However, it will be understood that the scope of the present disclosure is not limited to the bearing 75 being a needle bearing as the bearing 75 could also include a bushing, low-friction coating, etc.

In one embodiment, the bearing 75 is engaged with an inner diameter of a central hole of the cable spool 37. In another embodiment, a rotary plain bearing is formed between the outer surface 73 of the bearing mount 71 and the inner diameter of the central hole of the cable spool 37. In this embodiment, the outer diameter of the bearing mount 71 is sized to fit within an inner diameter of a central hole of the spooling portion 39. The engagement of the bearing mount 71 and the spooling portion 39 of the cable spool 37 allows the cable spool 37 to rotate about the central axis 77 of the bearing mount 71.

Referring now to FIGS. 1 and 5, the subscriber cable 22, which includes multiple optical fibers, is coiled around the spooling portion 39 of the cable spool 37. In order to protect the subscriber cable 22 from attenuation resulting from the coiling of the subscriber cable 22 around the spooling portion 39, the cable spool 37 has an outer circumferential surface having a radius that is greater than the minimum bend radius of the subscriber cable 22. The subscriber cable 22 includes a first end having connectorized ends, which are inserted through the cable passage 63 and connectedly engaged with the first ends 413 of the adapters 401. A second end of the subscriber cable 22 is configured for connectivity with the fiber distribution hub 17. However, as shown in

5

FIG. 1, the length of subscriber cable 22 needed between each of the fiber optic enclosures 21 in the facility 13 and the fiber distribution hub 17 will vary depending upon the location of each fiber optic enclosure 21 with respect to the fiber distribution hub 17.

A method of installing and using the fiber optic enclosure 21 to account for the varying lengths of subscriber cable 22 needed between the fiber optic enclosure 21 and the fiber distribution hub 17 will now be described. The fiber optic enclosure 21 provides dual functionality by serving as a storage location for the subscriber cable 22 and by selectively paying out a desired length of the subscriber cable 22.

A first length of subscriber cable 22 is stored in the fiber optic enclosure 21 by coiling the length of subscriber cable 22 around the cable spool 37. The first length of subscriber cable 22 includes an installation length, which is sufficiently long to extend from the mounting location of the enclosure 28 to the fiber distribution hub 17, and an excess length, which is the length of subscriber cable 22 remaining on the cable spool 37 after the installation length has been paid out. In one embodiment, the first length is greater than or equal to about 100 feet. In another embodiment, the first length of subscriber cable 22 is greater than or equal to about 200 feet. In another embodiment, the first length of subscriber cable 22 is greater than or equal to about 300 feet. In another embodiment, the first length of subscriber cable 22 is greater than or equal to about 400 feet. In another embodiment, the first length of subscriber cable 22 is greater than or equal to about 500 feet. In another embodiment, the first length of subscriber cable 22 is in the range of about 100 to about 2,000 feet. In another embodiment, the first length of subscriber cable 22 is in the range of about 100 to about 1,500 feet. In another embodiment, the first length of subscriber cable 22 is in the range of about 500 to about 1,500 feet. In a preferred embodiment, the first length of subscriber cable 22, which is coiled around the cable spool 89, is in the range of 100 to 500 feet.

In one embodiment, a second length, or the excess length, of subscriber cable 22 is stored around the cable spool 37 after the first length of subscriber cable 22 has been paid out. If the first length of subscriber cable 22 is greater than the installation length of subscriber cable 22, the second length, or excess length, is stored around the cable spool 37.

The second function of the fiber optic enclosure 21 involves the selective payout of the subscriber cable 22. With the cable spool 37 mounted to the bearing mount 71, the first end of the subscriber cable 22 in connected engagement with the front sides 413 of the adapters 401 and the outgoing optical fibers disengaged from the back sides of the adapters 401, the subscriber cable 22 can be paid out through fiber ports 79 disposed in the first and second sidewalls 29, 31. The subscriber cable 22 is paid out of the fiber optic enclosure 21 by selectively rotating the cable spool 37 with respect to the housing 23 about the central axis 77 of the bearing mount 71. As the termination module 45 is disposed on the axial end 41 of the cable spool 37, the selective rotation of the cable spool 37 with respect to the housing 23 results in the selective rotation of the termination module 45. Since the termination module 45 rotates unitarily with or in unison with the cable spool 37, the second end of the subscriber cable 22 can be paid out without the first end of the subscriber cable 22 being pulled out of the termination module 45.

Once the desired length of subscriber cable 22 has been paid out, the rotation of the cable spool 37 is ceased. At this point, the position of the cable spool 37 can be fixed such that it does not rotate relative to the housing 23. In one

6

embodiment, a pin is inserted through an opening in the axial end 41 of the cable spool 37 and through a corresponding opening in the base 27 of the housing 23 to fix the position of the cable spool 37 with respect to the housing 23. It will be understood, however, that the scope of the present disclosure is not limited to the use of a pin to fix the position of the cable spool 37 with respect to housing 23.

An alternate method of selectively paying-out subscriber cable 22 from the fiber optic enclosure 21 will now be described. With the fiber optic enclosure 21 positioned near the fiber distribution hub 17, the second end of the subscriber cable 22 is unwound from the cable spool 37. In one embodiment, the second end is optically connected to the fiber distribution hub 17. With the second end of the subscriber cable 22 optically connected to the fiber distribution hub 17 and the first end of the subscriber cable 22 in connected engagement with the termination module 45, the fiber optic enclosure 21 is transported away from the fiber distribution hub 17. In one embodiment, the fiber optic enclosure 21 is carried away from the fiber distribution hub 17 by an installer. In another embodiment, the fiber optic enclosure 21 is transported away from the fiber distribution hub 17 in a wheeled cart (e.g., dolly, 4-wheeled cart, etc.). In a preferred embodiment, the fiber optic enclosure is disposed in a packaging enclosure (e.g., a box) during transport. As the fiber optic enclosure 21 is transported away from the fiber distribution hub 17, the subscriber cable 22 unwinds from the cable spool 37 causing the cable spool 37 to rotate within the interior region 33 of the housing 23, which is disposed in the packaging enclosure. When the fiber optic enclosure 21 has been transported to its mounting location, the fiber optic enclosure 21 is removed from the packaging enclosure, mounted to the mounting location. The cable spool 37 can be fixed in position relative to the housing 23 to prevent inadvertent rotation of the cable spool 37.

Referring now to FIGS. 8-18, an alternate embodiment of a fiber optic enclosure 121 is shown. The fiber optic enclosure 121 includes a housing 123 and a hinged cover 125.

The housing 123 includes a base wall 120, a first sidewall 127 and an oppositely disposed second sidewall 128. The first and second sidewalls 127, 128 extend outwardly from the base wall 120 such that the base wall 120 and the first and second sidewalls 127, 128 cooperatively define an interior region 130.

In the subject embodiment, the first sidewall 127 of the housing 123 defines a first port 131 while the second sidewall 128 defines a second port 132. The subscriber cable 122 enters/exits the fiber optic enclosure 121 at the first port 131 or at the second port 132. In the subject embodiment, both of the first and second ports 131, 132 are provided as knockout portions.

A cable spool 137 is positioned within the interior region 130 of enclosure 121. In the subject embodiment, the cable spool 137 is adapted for rotation within the interior region 130 of the enclosure 121. In the subject embodiment, the cable spool 137 includes a first axial end 136, an oppositely disposed second axial end 138 and a spool portion 139. The spool portion 139 is disposed between the first and second axial ends 136, 138 of the cable spool 137. The spool portion 139 is adapted to receive a subscriber cable 122 coiled around or spooled on the spool portion 139.

With the subscriber cable 122 spooled on the spool portion 139, the subscriber cable 122 can be selectively paid out by rotating the cable spool 137. As the cable spool 137 is rotated, the subscriber cable 122 is unwound from the spool portion 139 of the cable spool 137. After a desired length of subscriber cable 122 has been paid out, pin

openings **141** can be used with a pin to fix the position of cable spool **137** relative to housing **123**.

The subscriber cable **122** is shown with a connectorized end **144** (e.g., MTP connector) for connecting to the fiber distribution hub **17** or other equipment. An opposite end of the subscriber cable **122** passes through an opening **145** disposed in the first axial end **136** of the cable spool **137**. After passing through the opening **145**, the subscriber cable **122** is routed to a fanout **147** disposed on the first axial end **136** of the cable spool **137** where the cable is broken out into individual fibers **124** having connectorized ends **146** (e.g., SC connectors).

A cable management spool **161** is also disposed on the first axial end **136** of the cable spool **137**. The cable management spool **161** manages fibers **124**. In the subject embodiment, the cable management spool **161** includes a plurality of fingers **162** disposed on an end of the cable management spool **161**. The fingers **162** assist with cable retention.

The first axial end **136** of the cable spool **137** further includes an outer guide wall **163**. In the subject embodiment, the outer guide wall **163** is disposed at a portion of the peripheral edge of the first axial end **136** adjacent to the cable management spool **161**. In the subject embodiment, the outer guide wall **163** extends outwardly in a direction that is generally perpendicular to the first axial end **136**.

The outer guide wall **163** includes with a cable finger **164** disposed at an end of the outer guide wall **163** that is opposite the end engaged with the first axial end **136** of the cable spool **137**. The cable finger **164** assists with retention and protection of the fibers **124**.

An adapter plate **149** is disposed on the first axial end **136** of the cable spool **137**. In the subject embodiment, the adapter plate **149** includes separate openings **151**. Each of the separate openings **151** is adapted to receive two adapters **401**.

In the depicted embodiment of FIG. **16**, the cable management spool **161**, the outer guide wall **163** and the adapter plate **149** are integrally formed with the first axial end **136** of the cable spool **137**. In the subject embodiment, the first axial end **136** of the cable spool **137** is formed from plastic. In another embodiment, the first and second axial ends **136**, **138**, the spool portion **139**, the adapter plate **149**, the cable management spool **161** and the outer guide wall **163** are integrally formed from a plastic material.

Referring now to FIGS. **13** and **14**, the fiber optic enclosure **121** is shown connected to a second subscriber cable **126**. After the subscriber cable **122** is paid out and cable spool **137** fixed in position relative to the housing **123**, individual connectorized ends of the second subscriber cables **126** can be connected to the fibers **124** at adapters **401** of adapter plate **149**. The second subscriber cables **126** exit the fiber optic enclosure **121** at a port **136** in a side **165** of the housing **123**. In the illustrated embodiment, a slotted foam member **138** is disposed in the port **136**. The slotted foam member **138** includes a plurality of slots through which the second subscriber cables **126** can be inserted in order to prevent or reduce the risk of ingress of environmental contamination (e.g., dust, water, etc.).

While the fiber optic enclosure **121** is shown mounted to a mounting location **183** (e.g., wall, pole, etc.) in FIGS. **1** and **17**, it will be understood that the subscriber cable **122** can be paid out from the fiber optic enclosure **121** while the fiber optic enclosure **121** is either mounted to a mounting location **183** or removed from the mounting location **183**. As shown in FIG. **18**, the subscriber cable **122** could be paid out while the fiber optic enclosure **121** is still packaged in a

shipping container **179** provided there is an opening **181** in the shipping container **179** through which the subscriber cable **122** can be pulled. After the subscriber cable **122** has been paid out, the fiber optic enclosure **121** can be removed from the shipping container **179** and mounted to the mounting location **183**.

Various modifications and alterations of this disclosure will become apparent to those skilled in the art without departing from the scope and spirit of this disclosure, and it should be understood that the inventive scope of this disclosure is not to be unduly limited to the illustrative embodiments set forth herein.

What is claimed is:

**1.** A method of connecting a subscriber to a fiber optic network using a fiber optic enclosure, the fiber optic enclosure including a main housing, a cable spool disposed within an interior of the main housing, an adapter disposed within the interior of the main housing, and a cover that selectively provides and blocks access to the interior of the main housing, the cable spool holding at least a portion of an optical cable that includes an optical fiber extending between a first end and a second end, the first end being terminated at a first optical connector and the second end being terminated at a second optical connector, the method comprising:

paying out a portion of the optical cable from the cable spool by rotating the cable spool while the second optical connector rotates in concert with the cable spool;

opening the cover to provide access to the interior of the main housing;

routing a connectorized end of a subscriber cable into the interior of the main housing;

plugging the connectorized end of the subscriber cable into the adapter; and

closing the cover to block access to the interior of the main housing after the subscriber cable is plugged into the adapter, wherein the adapter, the second optical connector, and the connectorized end of the subscriber cable remain disposed within the interior of the main housing when the cover is closed.

**2.** The method of claim **1**, wherein the adapter rotates in concert with the cable spool.

**3.** The method of claim **1**, further comprising mounting the main housing to a surface.

**4.** The method of claim **1**, wherein paying out the portion of the optical cable includes pulling on the optical cable at the first optical connector.

**5.** The method of claim **1**, wherein the second optical connector is plugged into the adapter before paying out the portion of the optical cable.

**6.** The method of claim **1**, further comprising optically coupling the first optical connector to the fiber optic network at a location remote from the fiber optic enclosure.

**7.** The method of claim **1**, wherein optically coupling the first optical connector to the fiber optic network is performed before mounting the main housing to the surface.

**8.** The method of claim **1**, wherein optically coupling the first optical connector to the fiber optic network is performed after mounting the main housing to the surface.

**9.** The method of claim **1**, wherein opening the cover comprises pivoting the cover relative to the main housing.

**10.** The method of claim **1**, wherein routing the connectorized end of the subscriber cable into the interior of the main housing comprises routing the connectorized end through a cable port.

11. The method of claim 10, wherein the main housing and the cover cooperate to define the cable port.

12. The method of claim 10, wherein the cable port is environmentally sealed.

13. The method of claim 12, wherein the cable port is sealed using a slitted sealing member.

14. The method of claim 12, wherein the cable port is sealed using a slitted foam member.

15. The method of claim 1, wherein the optical fiber is one of a plurality of optical fibers of the optical cable, and wherein a respective first end of each of the plurality of optical fibers is terminated at the first optical connector.

16. The method of claim 15, wherein a respective second end of each of the plurality of optical fibers is separately terminated at a respective second optical connector, each of the respective second optical connectors rotating in concert with the cable spool when the optical cable is paid out from the cable spool.

17. The method of claim 16, wherein the adapter is one of a plurality of adapters disposed within the interior of the main housing; and wherein each of the respective second optical connectors is plugged into one of the plurality of adapters.

18. The method of claim 17, wherein connectorized ends of additional subscriber cables are routed into the interior of the main housing and plugged into respective ones of the plurality of adapters when the cover is open.

19. The method of claim 1, wherein the cable spool rotates about an axis of rotation oriented to intersect the cover when the cover blocks access to the interior of the main housing.

20. A method of connecting a subscriber to a fiber optic network using a fiber optic enclosure, the fiber optical enclosure including a main housing and a cover, the main housing having opposite rear and front sides, the cover being movable relative to the main housing between an open position and a closed position, the cover blocking access to an interior of the main housing through the front side when in the closed position and allowing access to the interior through the front side when in the open position, the method comprising:

paying out an optical cable from a cable spool disposed within the interior of the main housing, the optical cable extending between a first end and a second end, the first end being routed away from the interior of the main housing while the optical cable is being paid out, the second end rotating in unison with the cable spool within the interior of the main housing while the optical cable is being paid out;

routing an end of a subscriber cable into the interior of the main housing while the cover is in the open position; optically coupling the end of the subscriber cable to the second end of the optical cable at an optical adapter disposed within the interior of the main housing while the cover is in the open position; and

moving the cover to the closed position to enclose the optical adapter, the end of the subscriber cable, and the second end of the cable within the interior of the main housing.

21. The method of claim 20, wherein paying out the optical cable includes pulling on the first end of the optical cable.

22. The method of claim 20, wherein the optical cable includes a plurality of optical fibers, wherein the plurality of optical fibers are connectorized at a multi-fiber connector at the first end of the optical cable; and wherein the plurality of optical fibers are individually connectorized at single-fiber connectors at the second end of the optical cable.

23. The method of claim 22, wherein the subscriber cable is one of a plurality of subscriber cables and the optical adapter is one of a plurality of optical adapters, and wherein the method further comprises:

plugging each of the single-fiber connectors into respective ones of the plurality of optical adapters within the interior of the main housing while the cover is in the open position; and

plugging connectorized ends of the subscriber cables into respective ones of the plurality of optical adapters while the cover is in the open position;

wherein moving the cover to the closed position encloses the plurality of optical adapters, the single-fiber connectors, and the connectorized ends of the plurality of subscriber cables.

24. The method of claim 20, further comprising mounting the rear side of the main housing to a wall.

25. A method of connecting a subscriber to a fiber optic network using a fiber optic enclosure, the fiber optical enclosure including a main housing and a cover, the main housing having opposite rear and front sides, the cover being movable relative to the main housing between an open position and a closed position, the cover blocking access to an interior of the main housing through the front side when in the closed position and allowing access to the interior through the front side when in the open position, the method comprising:

paying out an optical cable from a cable spool disposed within the interior of the main housing, the optical cable extending between a first end and a second end, the first end being routed away from the interior of the main housing while the optical cable is being paid out, the second end rotating in unison with the cable spool within the interior of the main housing while the optical cable is being paid out;

routing an end of a subscriber cable into the interior of the main housing while the cover is in the open position; optically coupling the end of the subscriber cable to the second end of the optical cable at an optical adapter disposed within the interior of the main housing while the cover is in the open position; and

moving the cover to the closed position to enclose the optical adapter, the end of the subscriber cable, and the second end of the cable within the interior of the main housing;

wherein the optical cable includes a plurality of optical fibers, wherein the plurality of optical fibers are connectorized at a multi-fiber connector at the first end of the optical cable; and

wherein the plurality of optical fibers are individually connectorized at single-fiber connectors at the second end of the optical cable;

wherein the subscriber cable is one of a plurality of subscriber cables and the optical adapter is one of a plurality of optical adapters, and wherein the method further comprises:

plugging each of the single-fiber connectors into respective ones of the plurality of optical adapters within the interior of the main housing while the cover is in the open position; and

plugging connectorized ends of the subscriber cables into respective ones of the plurality of optical adapters while the cover is in the open position;

wherein moving the cover to the closed position encloses the plurality of optical adapters, the single-fiber connectors, and the connectorized ends of the plurality of subscriber cables.

\* \* \* \* \*