



(12) **United States Patent**  
**Olson et al.**

(10) **Patent No.:** **US 10,343,114 B2**  
(45) **Date of Patent:** **\*Jul. 9, 2019**

(54) **SORBENTS FOR THE OXIDATION AND REMOVAL OF MERCURY**

(58) **Field of Classification Search**  
None  
See application file for complete search history.

(71) Applicant: **Midwest Energy Emissions Corp,**  
Lewis Center, OH (US)

(56) **References Cited**

(72) Inventors: **Edwin S. Olson,** Grand Forks, ND (US); **Michael J. Holmes,** Thompson, ND (US); **John H. Pavlish,** East Grand Forks, MN (US)

U.S. PATENT DOCUMENTS

1,984,164 A 12/1934 Stock  
2,317,857 A 4/1943 Soday  
(Continued)

(73) Assignee: **Midwest Energy Emissions Corp,**  
Lewis Center, OH (US)

FOREIGN PATENT DOCUMENTS

(\*) Notice: Subject to any disclaimer, the term of this patent is extended or adjusted under 35 U.S.C. 154(b) by 0 days.

CA 1099490 A 4/1981  
CA 2150529 A1 12/1995  
(Continued)

This patent is subject to a terminal disclaimer.

OTHER PUBLICATIONS

“U.S. Appl. No. 10/554,018 Response filed Nov. 1, 2010 to Final Office Action dated Apr. 27, 2010”, 17 pgs.  
(Continued)

(21) Appl. No.: **15/978,760**

(22) Filed: **May 14, 2018**

(65) **Prior Publication Data**  
US 2018/0257031 A1 Sep. 13, 2018

*Primary Examiner* — Amber R Orlando  
(74) *Attorney, Agent, or Firm* — Schwegman Lundberg & Woessner, P.A.

**Related U.S. Application Data**

(60) Continuation-in-part of application No. 15/295,594, filed on Oct. 17, 2016, which is a continuation of  
(Continued)

(57) **ABSTRACT**

(51) **Int. Cl.**  
**B01D 53/64** (2006.01)  
**B01J 20/34** (2006.01)  
(Continued)

A promoted carbon and/or non-carbon base sorbent are described that are highly effective for the removal of mercury from flue gas streams. The promoted sorbent comprises a carbon and/or non-carbon base sorbent that has reacted with and contains forms of halogen and halides. Optional components may be added to increase and/or preserve reactivity and mercury capacity. These may be added directly with the base sorbent, or in-flight within a gas stream (air, flue gas, etc.), to enhance base sorbent performance and/or mercury capture. Mercury removal efficiencies obtained exceed conventional methods. The promoted sorbent can be regenerated and reused. Base sorbent treatment and preparation methods are also described. New  
(Continued)

(52) **U.S. Cl.**  
CPC ..... **B01D 53/64** (2013.01); **B01D 53/10** (2013.01); **B01D 53/346** (2013.01); **B01D 53/83** (2013.01);  
(Continued)

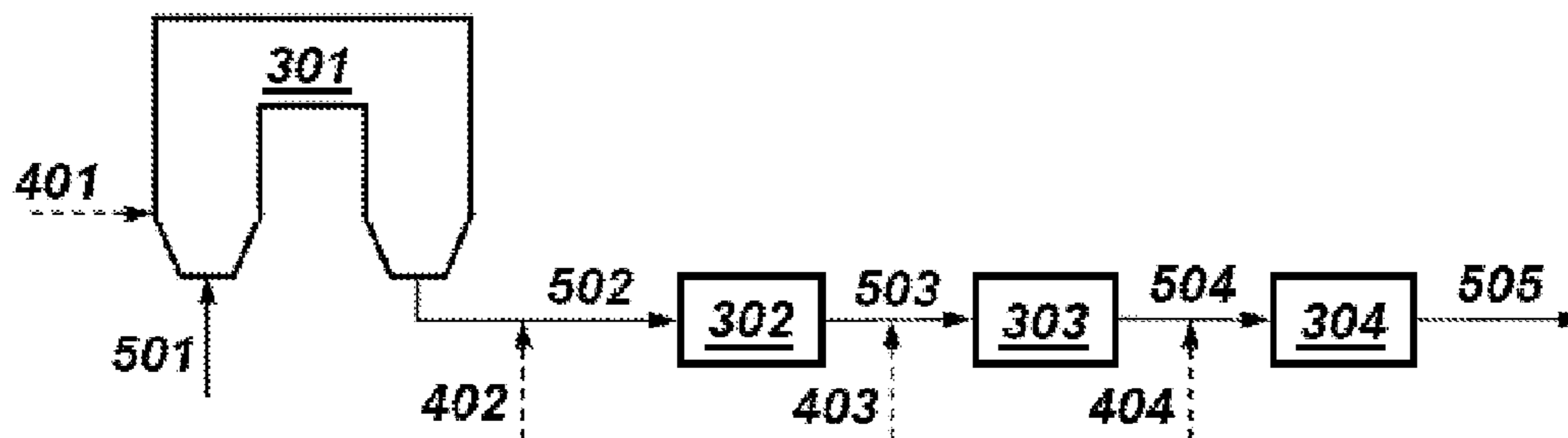

methods for in-flight preparation, introduction, and control of the active base sorbent into the mercury contaminated gas stream are described.

**30 Claims, 6 Drawing Sheets**

**Related U.S. Application Data**

application No. 14/102,896, filed on Dec. 11, 2013, now Pat. No. 9,468,886, which is a continuation of application No. 12/429,058, filed on Apr. 23, 2009, now Pat. No. 8,652,235, which is a continuation-in-part of application No. 12/201,595, filed on Aug. 29, 2008, which is a division of application No. 11/209,163, filed on Aug. 22, 2005, now Pat. No. 7,435,286.

(60) Provisional application No. 60/605,640, filed on Aug. 30, 2004.

(51) **Int. Cl.**

- B01J 20/22* (2006.01)
- B01J 20/28* (2006.01)
- B01J 20/20* (2006.01)
- B01J 20/12* (2006.01)
- B01J 20/10* (2006.01)
- B01J 20/04* (2006.01)
- B01J 20/02* (2006.01)
- B01D 53/34* (2006.01)
- B01D 53/83* (2006.01)
- B01D 53/96* (2006.01)
- B01D 53/10* (2006.01)

(52) **U.S. Cl.**

- CPC ..... *B01D 53/96* (2013.01); *B01J 20/027* (2013.01); *B01J 20/0262* (2013.01); *B01J 20/04* (2013.01); *B01J 20/041* (2013.01); *B01J 20/043* (2013.01); *B01J 20/10* (2013.01); *B01J 20/106* (2013.01); *B01J 20/12* (2013.01); *B01J 20/20* (2013.01); *B01J 20/223* (2013.01); *B01J 20/28004* (2013.01); *B01J 20/3416* (2013.01); *B01D 2251/108* (2013.01); *B01D 2253/102* (2013.01); *B01D 2257/602* (2013.01); *B01D 2258/0283* (2013.01); *B01D 2259/128* (2013.01); *B01J 2220/42* (2013.01)

(56) **References Cited**

U.S. PATENT DOCUMENTS

- 3,194,629 A 7/1965 Dreibelbis et al.
- 3,341,185 A 9/1967 Kennedy, Sr.
- 3,662,523 A 5/1972 Revoir et al.
- 3,786,619 A 1/1974 Melkersson
- 3,826,618 A 7/1974 Capuano
- 3,849,267 A 11/1974 Hilgen et al.
- 3,876,393 A 4/1975 Kasai et al.
- 3,935,708 A 2/1976 Harrewijne et al.
- 4,013,516 A 3/1977 Greenfield et al.
- 4,094,777 A 6/1978 Sugier et al.
- 4,101,631 A 7/1978 Ambrosini et al.
- 4,196,173 A 4/1980 DeJong et al.
- 4,338,896 A 7/1982 Papasideris
- 4,342,192 A 8/1982 Heyn et al.
- 4,500,327 A 2/1985 Nishino et al.
- 4,530,765 A 7/1985 Sabherwal
- 4,699,896 A 10/1987 Sing et al.
- 4,708,853 A 11/1987 Matviya et al.
- 4,772,455 A 9/1988 Izumi et al.

- 4,786,483 A 11/1988 Audeh
- 4,814,152 A 3/1989 Yan
- 4,820,318 A 4/1989 Chang et al.
- 4,889,698 A 12/1989 Moller et al.
- 4,956,162 A 9/1990 Smith et al.
- 5,245,120 A 9/1993 Srinivasachar et al.
- 5,288,306 A 2/1994 Aibe et al.
- 5,300,137 A 4/1994 Weyand et al.
- 5,336,835 A 8/1994 McNamara
- 5,346,674 A 9/1994 Weinwurm et al.
- 5,409,522 A 4/1995 Durham et al.
- 5,419,834 A 5/1995 Straten
- 5,435,980 A \* 7/1995 Felsvang ..... B01D 53/10  
423/210
- 5,462,908 A 10/1995 Liang et al.
- 5,480,619 A 1/1996 Johnson et al.
- 5,500,306 A 3/1996 Hsu et al.
- 5,505,766 A 4/1996 Chang
- 5,569,436 A \* 10/1996 Lerner ..... B01D 53/64  
110/235
- 5,575,982 A 11/1996 Reiss et al.
- 5,607,496 A 3/1997 Brooks
- 5,672,323 A 9/1997 Bhat et al.
- 5,695,726 A 12/1997 Lerner
- 5,785,935 A 7/1998 Fristad et al.
- 5,827,352 A 10/1998 Altman et al.
- 5,891,324 A 4/1999 Ohtsuka
- 6,001,762 A 12/1999 Harmer et al.
- 6,013,593 A 1/2000 Lee et al.
- 6,027,551 A 2/2000 Hwang et al.
- 6,074,974 A 6/2000 Lee et al.
- 6,080,281 A 6/2000 Attia
- 6,103,205 A 8/2000 Wojtowicz et al.
- 6,136,072 A 10/2000 Sjostrom et al.
- 6,136,749 A \* 10/2000 Gadkaree ..... B01D 53/8665  
502/180
- 6,214,304 B1 4/2001 Rosenthal et al.
- 6,258,334 B1 7/2001 Gadkaree et al.
- 6,284,199 B1 9/2001 Downs et al.
- 6,342,462 B1 1/2002 Kulprathipanja
- 2,456,272 A1 2/2002 Pahlman et al.
- 6,372,187 B1 \* 4/2002 Madden ..... B01D 53/508  
110/345
- 6,375,909 B1 4/2002 Dangtran et al.
- 6,383,981 B1 5/2002 Blankenship et al.
- 6,471,936 B1 10/2002 Chen et al.
- 6,475,451 B1 11/2002 Leppin et al.
- 6,475,471 B1 11/2002 Wehrli
- 6,528,030 B2 3/2003 Madden et al.
- 6,558,454 B1 \* 5/2003 Chang ..... B01D 53/10  
110/342
- 6,576,585 B2 6/2003 Fischer et al.
- 6,579,507 B2 6/2003 Pahlman et al.
- 6,596,661 B2 7/2003 Neufert
- 6,610,263 B2 8/2003 Pahlman et al.
- 6,638,485 B1 10/2003 Iida et al.
- 6,719,828 B1 \* 4/2004 Lovell ..... B01D 53/02  
423/210
- 6,808,692 B2 10/2004 Oehr
- 6,818,043 B1 \* 11/2004 Chang ..... B01D 53/64  
423/213.2
- 6,848,374 B2 \* 2/2005 Srinivasachar ..... B01D 53/10  
110/165 R
- 6,878,358 B2 4/2005 Vosteen et al.
- 6,942,840 B1 9/2005 Broderick
- 6,953,494 B2 10/2005 Nelson, Jr. et al.
- 6,960,329 B2 11/2005 Sellakumar
- 7,017,330 B2 3/2006 Bellows
- 7,081,434 B2 7/2006 Sinha
- 7,124,591 B2 10/2006 Baer et al.
- 7,211,707 B2 5/2007 Axtell et al.
- 7,247,279 B2 7/2007 Pahlman et al.
- 7,293,414 B1 11/2007 Huber
- 7,435,286 B2 10/2008 Olson et al.
- 7,442,239 B2 10/2008 Armstrong et al.
- 7,479,263 B2 1/2009 Chang et al.
- 7,514,052 B2 \* 4/2009 Lissianski ..... B01D 53/56  
423/210

(56)

References Cited

U.S. PATENT DOCUMENTS

7,521,032 B2 4/2009 Honjo et al.  
 7,544,338 B2 6/2009 Honjo et al.  
 7,563,311 B2 7/2009 Graham  
 7,611,564 B2 11/2009 Mcchesney et al.  
 7,622,092 B2 11/2009 Honjo et al.  
 7,722,843 B1 5/2010 Srinivasachar  
 7,767,174 B2 8/2010 Lui et al.  
 7,780,765 B2\* 8/2010 Srinivasachar ..... B01D 53/10  
 110/203  
 7,938,571 B1 5/2011 Irvine  
 7,942,566 B1 5/2011 Irvine  
 8,007,749 B2 8/2011 Chang et al.  
 8,080,088 B1 12/2011 Srinivasachar  
 8,168,147 B2 5/2012 Olson et al.  
 8,168,149 B2 5/2012 Gal et al.  
 8,173,566 B2 5/2012 Olson et al.  
 8,216,535 B2 7/2012 Pollack et al.  
 8,512,655 B2 8/2013 Olson et al.  
 8,652,235 B2 2/2014 Olson et al.  
 8,821,819 B2 9/2014 Olson et al.  
 9,011,805 B2 4/2015 Olson et al.  
 9,468,886 B2 10/2016 Olson et al.  
 9,662,629 B2 5/2017 Olson et al.  
 9,669,355 B2 6/2017 Olson et al.  
 9,757,689 B2 9/2017 Olson et al.  
 10,130,930 B2 11/2018 Olson  
 2001/0002387 A1 5/2001 Tsutsumi et al.  
 2001/0003116 A1 6/2001 Neufert  
 2002/0033097 A1 3/2002 El-shoubary et al.  
 2002/0043496 A1 4/2002 Boddu et al.  
 2002/0134242 A1 9/2002 Yang et al.  
 2002/0150516 A1 10/2002 Pahlman et al.  
 2003/0057293 A1 3/2003 Boecking  
 2003/0104937 A1 6/2003 Sinha  
 2003/0136509 A1 7/2003 Virtanen  
 2003/0206843 A1 11/2003 Nelson, Jr.  
 2003/0206846 A1 11/2003 Jangbarwala  
 2004/0003716 A1\* 1/2004 Nelson, Jr. .... B01D 53/02  
 95/134  
 2004/0013589 A1 1/2004 Vosteen et al.  
 2004/0076570 A1 4/2004 Jia  
 2004/0086439 A1\* 5/2004 Vosteen ..... B01D 53/64  
 423/210  
 2004/0109800 A1 6/2004 Pahlman et al.  
 2005/0000197 A1 1/2005 Krantz  
 2005/0019240 A1 1/2005 Lu et al.  
 2005/0074380 A1 4/2005 Boren et al.  
 2005/0147549 A1 7/2005 Lissianski et al.  
 2005/0227146 A1 10/2005 Ghantous et al.  
 2006/0048646 A1\* 3/2006 Olson ..... B01D 53/10  
 95/134  
 2006/0057044 A1 3/2006 Chang et al.  
 2006/0112823 A1 6/2006 Avina  
 2006/0191835 A1 8/2006 Petrik et al.  
 2006/0204418 A1 9/2006 Chao et al.  
 2007/0167309 A1 7/2007 Olson  
 2007/0168213 A1 7/2007 Comrie  
 2007/0180990 A1\* 8/2007 Downs ..... B01D 53/10  
 95/134  
 2007/0234902 A1 10/2007 Fair et al.  
 2007/0295347 A1 12/2007 Paine, III et al.  
 2008/0090951 A1 4/2008 Mao et al.  
 2008/0107579 A1 5/2008 Downs et al.  
 2008/0134888 A1 6/2008 Chao et al.  
 2008/0182747 A1 7/2008 Sinha  
 2008/0207443 A1 8/2008 Gadkaree et al.  
 2008/0292512 A1 11/2008 Kang  
 2009/0031708 A1 2/2009 Schmidt  
 2009/0062119 A1 3/2009 Olson et al.  
 2009/0081092 A1 3/2009 Yang et al.  
 2009/0136401 A1 5/2009 Yang et al.  
 2009/0235848 A1 9/2009 Eiteneer et al.  
 2009/0297413 A1\* 12/2009 Olson ..... B01D 53/10  
 423/215.5

2009/0320678 A1\* 12/2009 Chang ..... B01D 46/002  
 95/92  
 2010/0024642 A1 2/2010 Fukumoto et al.  
 2010/0047146 A1 2/2010 Olson et al.  
 2011/0076210 A1 3/2011 Pollack et al.  
 2011/0168018 A1 7/2011 Mohamadalizadeh et al.  
 2012/0183458 A1 7/2012 Olson et al.  
 2012/0244355 A1 9/2012 Pollack et al.  
 2013/0280156 A1 10/2013 Olson et al.  
 2014/0056787 A1 2/2014 Olson et al.  
 2014/0224121 A1 8/2014 Mimna et al.  
 2014/0255279 A1 9/2014 Olson et al.  
 2014/0308188 A1 10/2014 Olson et al.  
 2015/0098878 A1\* 4/2015 Olson ..... B01J 20/12  
 423/210  
 2015/0246315 A1 9/2015 Olson et al.  
 2017/0100692 A1\* 4/2017 Olson ..... B01D 53/08  
 2017/0128908 A1 5/2017 Olson et al.  
 2017/0173524 A1 6/2017 Olson et al.  
 2017/0173557 A1 6/2017 Olson et al.  
 2017/0239644 A1\* 8/2017 Olson ..... B01D 53/02  
 2018/0133646 A1\* 5/2018 Pavlish ..... B01J 20/3416  
 2018/0229182 A1 8/2018 Olson et al.  
 2018/0257030 A1 9/2018 Olson et al.  
 2018/0257031 A1\* 9/2018 Olson ..... B01J 20/3416  
 2018/0280870 A1 10/2018 Olson et al.  
 2019/0009247 A1 1/2019 Olson et al.

FOREIGN PATENT DOCUMENTS

CA 2327602 A1 6/2001  
 CA 2400898 A1 8/2001  
 CA 2584327 A1 4/2006  
 CA 2757309 A1 10/2010  
 CA 2757309 C 1/2017  
 CN 1048173 A 1/1991  
 CN 101048218 A 10/2007  
 CN 101053820 A 10/2007  
 CN 101293196 A 10/2008  
 CN 101816922 A 9/2010  
 CN 102413899 A 4/2012  
 CN 104519410 A 4/2015  
 CN 105188910 A 12/2015  
 CN 104619410 B 5/2016  
 CN 107661744 A 2/2018  
 DE 3426059 A1 1/1986  
 DE 3816600 A1 11/1989  
 DE 10233173 A1 2/2004  
 DE 202012003747 U1 11/2012  
 EP 0208490 A1 1/1987  
 EP 1386655 A1 2/2004  
 EP 1458474 9/2004  
 EP 1570894 A1 9/2005  
 FR 2529802 1/1984  
 GB 2122916 A 1/1984  
 JP 4953590 A 5/1974  
 JP 4953593 A 5/1974  
 JP 4966592 A 6/1974  
 JP 4943197 B4 11/1974  
 JP 506438 B4 3/1975  
 JP 51003386 A 1/1976  
 JP 544868 A 1/1979  
 JP 50145324 A 3/1980  
 JP 09256812 9/1997  
 KR 1020027006149 7/2002  
 SU 732207 A1 5/1980  
 SU 1163982 A 6/1985  
 WO WO-0162368 A1 8/2001  
 WO WO-0228513 A2 4/2002  
 WO WO-03072241 A1 9/2003  
 WO WO-2004089501 A2 10/2004  
 WO WO-2004094024 A2 11/2004  
 WO WO-2006039007 A2 4/2006  
 WO WO-2006039007 A3 4/2006  
 WO WO-2006099611 A1 9/2006  
 WO WO-2009018539 A3 2/2009  
 WO WO-2010123609 A1 10/2010

(56)

**References Cited**

## FOREIGN PATENT DOCUMENTS

WO	WO-2013162968 A2	10/2013
WO	WO-2013162968 A3	10/2013
WO	WO-2014137907 A2	9/2014

## OTHER PUBLICATIONS

“U.S. Appl. No. 10/554,018, Final Office Action dated Apr. 27, 2010”, 8 pgs.  
 “U.S. Appl. No. 10/554,018, Non Final Office Action dated Oct. 6, 2009”, 8 pgs.  
 “U.S. Appl. No. 10/554,018, Notice of Allowance dated Jan. 19, 2012”, 7 pgs.  
 “U.S. Appl. No. 10/554,018, Response filed Feb. 8, 2010 to Non Final Office Action dated Oct. 6, 2009”, 9 pgs.  
 “U.S. Appl. No. 10/554,018, Response filed Aug. 10, 2009 to Restriction Requirement dated Jun. 9, 2009”, 1 pg.  
 “U.S. Appl. No. 10/554,018, Restriction Requirement dated Jun. 9, 2009”, 5 pgs.  
 “U.S. Appl. No. 11/209,163, Advisory Action dated Apr. 21, 2008”, 3 pgs.  
 “U.S. Appl. No. 11/209,163, Final Office Action dated Jan. 23, 2008”, 20 pgs.  
 “U.S. Appl. No. 11/209,163, Non Final Office Action dated Aug. 13, 2007”, 14 pgs.  
 “U.S. Appl. No. 11/209,163, Notice of Allowance dated Jul. 14, 2008”, 7 pgs.  
 “U.S. Appl. No. 11/209,163, Preliminary Amendment filed Feb. 27, 2007”, 9 pgs.  
 “U.S. Appl. No. 11/209,163, Response filed Mar. 24, 2008 to Final Office Action dated Jan. 23, 2008”, 29 pgs.  
 “U.S. Appl. No. 11/209,163, Response filed Jul. 9, 2007 to Restriction Requirement dated Jun. 7, 2007”, 2 pgs.  
 “U.S. Appl. No. 11/209,163, Response filed Nov. 13, 2007 to Non Final Office Action dated Aug. 13, 2007”, 19 pgs.  
 “U.S. Appl. No. 11/209,163, Restriction Requirement dated Jun. 7, 2007”, 6 pgs.  
 “U.S. Appl. No. 12/184,860, Examiner Interview Summary dated Apr. 5, 2011”, 3 pgs.  
 “U.S. Appl. No. 12/184,860, Final Office Action dated May 11, 2011”, 15 pgs.  
 “U.S. Appl. No. 12/184,860, Non Final Office Action dated Jan. 19, 2011”, 14 pgs.  
 “U.S. Appl. No. 12/184,860, Response filed Apr. 7, 2011 to Non Final Office Action dated Jan. 19, 2011”, 12 pgs.  
 “U.S. Appl. No. 12/184,860, Response filed Jul. 8, 2011 to Final Office Action dated May 11, 2011”, 11 pgs.  
 “U.S. Appl. No. 12/201,595, Final Office Action dated Mar. 10, 2010”, 13 pgs.  
 “U.S. Appl. No. 12/201,595, Non Final Office Action dated Apr. 16, 2009”, 21 pgs.  
 “U.S. Appl. No. 12/201,595, Response filed Oct. 16, 2009 to Non Final Office Action dated Apr. 16, 2009”, 18 pgs.  
 “U.S. Appl. No. 12/419,219, Final Office Action dated Oct. 14, 2010”, 17 pgs.  
 “U.S. Appl. No. 12/419,219, Non Final Office Action dated Jan. 15, 2010”, 13 pgs.  
 “U.S. Appl. No. 12/419,219, Non Final Office Action dated Feb. 23, 2011”, 17 pgs.  
 “U.S. Appl. No. 12/419,219, Non Final Office Action dated Aug. 4, 2011”, 16 pgs.  
 “U.S. Appl. No. 12/419,219, Notice of Allowance dated Jan. 10, 2012”, 7 pgs.  
 “U.S. Appl. No. 12/419,219, Preliminary Amendment filed Apr. 6, 2009”, 7 pgs.  
 “U.S. Appl. No. 12/419,219, Response filed Feb. 14, 2011 to Final Office Action dated Oct. 14, 2010”, 19 pgs.  
 “U.S. Appl. No. 12/419,219, Response filed May 20, 2011 to Non Final Office Action dated Feb. 23, 2011”, 14 pgs.

“U.S. Appl. No. 12/419,219, Response filed Jul. 15, 2010 to Non Final Office Action dated Jan. 15, 2010”, 22 pgs.  
 “U.S. Appl. No. 12/419,219, Response filed Oct. 27, 2011 to Non Final Office Action dated Aug. 4, 2011”, 12 pgs.  
 “U.S. Appl. No. 12/429,058, Advisory Action dated May 29, 2012”, 3 pgs.  
 “U.S. Appl. No. 12/429,058, Ex Parte Quayle Action mailed Feb. 14, 2013”, 7 pgs.  
 “U.S. Appl. No. 12/429,058, Examiner Interview Summary dated Dec. 28, 2012”, 4 pgs.  
 “U.S. Appl. No. 12/429,058, Final Office Action dated Oct. 31, 2012”, 21 pgs.  
 “U.S. Appl. No. 12/429,058, Final Office Action dated Dec. 20, 2011”, 21 pgs.  
 “U.S. Appl. No. 12/429,058, Non Final Office Action dated Jun. 11, 2012”, 18 pgs.  
 “U.S. Appl. No. 12/429,058, Non Final Office Action dated Jul. 19, 2011”, 20 pgs.  
 “U.S. Appl. No. 12/429,058, Notice of Allowance dated Jan. 16, 2014”, 5 pgs.  
 “U.S. Appl. No. 12/429,058, Notice of Allowance dated Sep. 11, 2013”, 11 pgs.  
 “U.S. Appl. No. 12/429,058, Response filed Jan. 31, 2013 to Final Office Action dated Oct. 31, 2012”, 19 pgs.  
 “U.S. Appl. No. 12/429,058, Response filed Mar. 7, 2013 to Ex Parte Quayle Action mailed Feb. 14, 2013”, 7 pgs.  
 “U.S. Appl. No. 12/429,058, Response filed May 11, 2012 to Final Office Action dated Dec. 20, 2011”, 11 pgs.  
 “U.S. Appl. No. 12/429,058, Response filed Sep. 11, 2012 to Non Final Office Action dated Jun. 11, 2012”, 16 pgs.  
 “U.S. Appl. No. 12/429,058, Response filed Oct. 18, 2011 to Non Final Office Action dated Jul. 19, 2011”, 17 pgs.  
 “U.S. Appl. No. 13/427,665, Non Final Office Action dated Jan. 4, 2013”, 23 pgs.  
 “U.S. Appl. No. 13/427,665, Non Final Office Action dated Aug. 3, 2012”, 12 pgs.  
 “U.S. Appl. No. 13/427,665, Notice of Allowance dated Apr. 16, 2013”, 8 pgs.  
 “U.S. Appl. No. 13/427,665, Response filed Mar. 21, 2013 to Non Final Office Action dated Jan. 4, 2013”, 20 pgs.  
 “U.S. Appl. No. 13/427,665, Response filed Oct. 10, 2012 to Non Final Office Action dated Aug. 3, 2012”, 15 pgs.  
 “U.S. Appl. No. 13/427,685, Preliminary Amendment filed Mar. 22, 2012”, 3 pgs.  
 “U.S. Appl. No. 13/453,274, Advisory Action dated Nov. 24, 2014”, 3 pgs.  
 “U.S. Appl. No. 13/453,274, Final Office Action dated Oct. 16, 2014”, 4 pgs.  
 “U.S. Appl. No. 13/453,274, Non Final Office Action dated May 30, 2014”, 6 pgs.  
 “U.S. Appl. No. 13/453,274, Notice of Allowance dated Jan. 5, 2015”, 5 pgs.  
 “U.S. Appl. No. 13/453,274, Response filed Sep. 2, 2014 to Non Final Office Action dated May 30, 2014”, 13 pgs.  
 “U.S. Appl. No. 13/453,274, Response filed Nov. 6, 2014 to Final Office Action dated Oct. 16, 2014”, 7 pgs.  
 “U.S. Appl. No. 13/453,274, Response filed Dec. 9, 2014 to Advisory Action dated Nov. 24, 2014”, 6 pgs.  
 “U.S. Appl. No. 13/966,768, Non Final Office Action dated Dec. 6, 2013”, 7 pgs.  
 “U.S. Appl. No. 13/966,768, Notice of Allowability dated Aug. 1, 2014”, 6 pgs.  
 “U.S. Appl. No. 13/966,768, Notice of Allowance dated Apr. 18, 2014”, 7 pgs.  
 “U.S. Appl. No. 13/966,768, Preliminary Amendment filed Aug. 14, 2013”, 3 pgs.  
 “U.S. Appl. No. 13/966,768, Response filed Mar. 6, 2014 to Non Final Office Action dated Dec. 6, 2013”, 6 pgs.  
 “U.S. Appl. No. 13/966,768, Supplemental Preliminary Amendment filed Aug. 15, 2013”, 6 pgs.  
 “U.S. Appl. No. 14/102,896, Advisory Action dated Dec. 16, 2015”, 3 pgs.

(56)

**References Cited**

## OTHER PUBLICATIONS

- “U.S. Appl. No. 14/102,896, Final Office Action dated Aug. 26, 2015”, 12 pgs.
- “U.S. Appl. No. 14/102,896, Non Final Office Action dated Mar. 23, 2015”, 13 pgs.
- “U.S. Appl. No. 14/102,896, Notice of Allowance dated Jun. 10, 2016”, 7 pgs.
- “U.S. Appl. No. 14/102,896, Response filed Jan. 22, 2016 to Advisory Action dated Dec. 16, 2015”, 11 pgs.
- “U.S. Appl. No. 14/102,896, Response filed Jun. 22, 2015 to Non Final Office Action dated Mar. 23, 2015”, 10 pgs.
- “U.S. Appl. No. 14/102,896, Response filed Nov. 24, 2015 to Final Office Action dated Aug. 26, 2015”, 5 pgs.
- “U.S. Appl. No. 14/195,360, Corrected Notice of Allowance dated Feb. 27, 2017”, 2 pgs.
- “U.S. Appl. No. 14/195,360, Corrected Notice of Allowance dated Mar. 29, 2017”, 2 pgs.
- “U.S. Appl. No. 14/195,360, Final Office Action dated Mar. 18, 2016”, 18 pgs.
- “U.S. Appl. No. 14/195,360, Final Office Action dated Nov. 22, 2016”, 7 pgs.
- “U.S. Appl. No. 14/195,360, Non Final Office Action dated Jun. 20, 2016”, 11 pgs.
- “U.S. Appl. No. 14/195,360, Non Final Office Action dated Nov. 24, 2015”, 19 pgs.
- “U.S. Appl. No. 14/195,360, Notice of Allowance dated Feb. 7, 2017”, 5 pgs.
- “U.S. Appl. No. 14/195,360, Response filed Jan. 18, 2017 to Final Office Action dated Nov. 22, 2016”, 7 pgs.
- “U.S. Appl. No. 14/195,360, Response filed Feb. 22, 2016 to Non Final Office Action dated Nov. 24, 2015”, 21 pgs.
- “U.S. Appl. No. 14/195,360, Response filed May 17, 2016 to Final Office Action dated Mar. 18, 2016”, 15 pgs.
- “U.S. Appl. No. 14/318,270, Advisory Action dated Feb. 17, 2017”, 4 pgs.
- “U.S. Appl. No. 14/318,270, Corrected Notice of Allowance dated May 22, 2017”, 2 pgs.
- “U.S. Appl. No. 14/318,270, Final Office Action dated Nov. 25, 2016”, 25 pgs.
- “U.S. Appl. No. 14/318,270, Non Final Office Action dated Jun. 2, 2016”, 24 pgs.
- “U.S. Appl. No. 14/318,270, Notice of Allowance dated May 15, 2017”, 8 pgs.
- “U.S. Appl. No. 14/318,270, Response filed Jan. 25, 2017 to Final Office Action dated Nov. 25, 2016”, 14 pgs.
- “U.S. Appl. No. 14/318,270, Response filed Feb. 27, 2017 to Final Office Action dated Nov. 25, 2016”, 15 pgs.
- “U.S. Appl. No. 14/318,270, Response filed Mar. 2, 2016 to Restriction Requirement dated Jan. 14, 2016”, 9 pgs.
- “U.S. Appl. No. 14/318,270, Response filed Aug. 22, 2016 to Non Final Office Action dated Jun. 2, 2016”, 14 pgs.
- “U.S. Appl. No. 14/318,270, Restriction Requirement dated Jan. 14, 2016”, 8 pgs.
- “U.S. Appl. No. 14/564,860, Final Office Action dated Nov. 17, 2016”, 4 pgs.
- “U.S. Appl. No. 14/564,860, Non Final Office Action dated Jul. 12, 2016”, 6 pgs.
- “U.S. Appl. No. 14/564,860, Notice of Allowance dated Jan. 30, 2017”, 6 pgs.
- “U.S. Appl. No. 14/564,860, Preliminary Amendment filed Dec. 10, 2014”, 8 pgs.
- “U.S. Appl. No. 14/564,860, Preliminary Amendment filed Dec. 10, 2014”, 6 pgs.
- “U.S. Appl. No. 14/564,860, Response filed May 6, 2016 to Restriction Requirement dated Mar. 16, 2016”, 9 pgs.
- “U.S. Appl. No. 14/564,860, Response filed Oct. 3, 2016 to Non Final Office Action dated Jul. 12, 2016”, 11 pgs.
- “U.S. Appl. No. 14/564,860, Restriction Requirement dated Mar. 16, 2016”, 5 pgs.
- “U.S. Appl. No. 14/712,558, Advisory Action dated Feb. 12, 2018”, 8 pgs.
- “U.S. Appl. No. 14/712,558, Examiner Interview Summary dated Mar. 5, 2018”, 3 pgs.
- “U.S. Appl. No. 14/712,558, Final Office Action dated Dec. 6, 2017”, 9 pgs.
- “U.S. Appl. No. 14/712,558, Non Final Office Action dated Jul. 6, 2017”, 7 pgs.
- “U.S. Appl. No. 14/712,558, Response filed Jan. 23, 2018 to Final Office Action dated Dec. 6, 2017”, 13 pgs.
- “U.S. Appl. No. 14/712,558, Response filed Apr. 2, 2018 to Final Office Action dated Dec. 6, 2017”, 7 pgs.
- “U.S. Appl. No. 14/712,558, Response filed Oct. 6, 2017 to Non Final Office Action dated Jul. 6, 2017”, 12 pgs.
- “U.S. Appl. No. 14/712,558, Supplemental Amendment Filed May 15, 2018”, 6 pgs.
- “U.S. Appl. No. 14/712,558, Supplemental Preliminary Amendment filed May 15, 2015”, 6 pgs.
- “U.S. Appl. No. 15/295,594, Preliminary Amendment filed Jan. 26, 2017”, 8 pgs.
- “U.S. Appl. No. 15/295,594, Preliminary Amendment filed Jun. 13, 2017”, 7 pgs.
- “U.S. Appl. No. 15/382,114, Preliminary Amendment filed Apr. 4, 2017”, 3 pgs.
- “U.S. Appl. No. 15/449,112, Advisory Action dated Apr. 24, 2018”, 3 pgs.
- “U.S. Appl. No. 15/449,112, Final Office Action dated Feb. 15, 2018”, 13 pgs.
- “U.S. Appl. No. 15/449,112, Non Final Office Action dated Sep. 27, 2017”, 17 pgs.
- “U.S. Appl. No. 15/449,112, Response filed Jan. 16, 2018 to Non Final Office Action dated Sep. 27, 2017”, 16 pgs.
- “U.S. Appl. No. 15/449,112, Response filed Feb. 15, 2018 to Final Office Action dated Feb. 15, 2018”, 13 pgs.
- “U.S. Appl. No. 15/449,112, Response filed Apr. 6, 2018 to Final Office Action dated Feb. 15, 2018”, 13 pgs.
- “U.S. Appl. No. 15/452,527, Preliminary Amendment filed Mar. 8, 2017”, 3 pgs.
- “U.S. Appl. No. 15/589,359, Non Final Office Action dated Feb. 21, 2018”, 15 pgs.
- “U.S. Appl. No. 15/589,359, Preliminary Amendment filed Jan. 3, 2018”, 6 pgs.
- “Application Serial No. PCT/US04/12828, International Search Report dated Oct. 22, 2004”, 2 pgs.
- “Application Serial No. PCT/US2014/019916, International Preliminary Report on Patentability dated Sep. 17, 2015”, 14 pgs.
- “U.S. Appl. No. 14/195,360, Response filed Sep. 16, 2016 to Non Final Office Action dated Jun. 30, 2016”, 12 pgs.
- “Bromine and its Compounds”, Jolles, Z. E., Editor, Academic Press, Inc., New York, NY, (1966), pp. 193 and 205.
- “Canadian Application Serial No. 2,523,132, Office Action dated Jul. 18, 2011”, 3 pgs.
- “Canadian Application Serial No. 2,523,132, Response filed Jan. 16, 2012 to Office Action dated Jul. 18, 2011”, 5 pgs.
- “Canadian Application Serial No. 2,584,327, Office Action dated Mar. 3, 2009”, 4 pgs.
- “Canadian Application Serial No. 2,584,327, Office Action dated Dec. 7, 2009”, 2 pgs.
- “Canadian Application Serial No. 2,584,327, Response filed Mar. 19, 2010 to Office Action dated Dec. 7, 2009”, 8 pgs.
- “Canadian Application Serial No. 2,584,327, Response filed Sep. 2, 2009 to Office Action dated Mar. 3, 2009”, 21 pgs.
- “Canadian Application Serial No. 2,707,363, First Examiners Report”, 2 pgs.
- “Canadian Application Serial No. 2,757,309, Office Action dated Dec. 7, 2015”, 3 pgs.
- “Canadian Application Serial No. 2,757,309, Response filed Jun. 6, 2016 to Office Action dated Dec. 7, 2015”, 13 pgs.
- “Canadian Application Serial No. 2,757,309, Voluntary Amendment filed Jan. 30, 2015”, 27 pgs.
- “Canadian Application Serial No. 2,871,422, Response filed Feb. 26, 2016 to Office Action dated Sep. 9, 2015”, 13 pgs.

(56)

**References Cited**

## OTHER PUBLICATIONS

“Canadian Application Serial No. 2,871,422, Office Action dated Apr. 2, 2015”, 5 pgs.  
 “Canadian Application Serial No. 2,871,422, Office Action dated Apr. 24, 2018”, 4 pgs.  
 “Canadian Application Serial No. 2,871,422, Office Action dated Aug. 31, 2017”, 4 pgs.  
 “Canadian Application Serial No. 2,871,422, Office Action dated Sep. 9, 2015”, 3 pgs.  
 “Canadian Application Serial No. 2,871,422, Office Action dated Dec. 22, 2016”, 5 pgs.  
 “Canadian Application Serial No. 2,871,422, Response filed Feb. 26, 2018 to Office Action dated Aug. 31, 2017”, w/ Amended Claims, 53 pgs.  
 “Canadian Application Serial No. 2,871,422, Response filed Jun. 21, 2017 to Office Action dated Dec. 22, 2016”, 41 pgs.  
 “Canadian Application Serial No. 2,871,422, Response filed Aug. 28, 2015 to Canadian Office Action dated Apr. 2, 2015”, 22 pgs.  
 “Chinese Application Serial No. 200480017704.4, Office Action dated Dec. 8, 2011”, (w/ English Translation), 6 pgs.  
 “Chinese Application Serial No. 200480017704.4, Response filed Jan. 20, 2012 to Office Action dated Dec. 8, 2012”, (w/ English Translation of Amended Claims), 10 pgs.  
 “Chinese Application Serial No. 200580037037.0, Chinese Office Action, dated Jun. 25, 2013 (and English translation)”, no english translation, 46 pgs.  
 “Chinese Application Serial No. 201380033231.6, Office Action dated Sep. 21, 2015”, w/ Partial English Translation, 6 pgs.  
 “Chinese Application Serial No. 201380033231.6, Response filed Jan. 14, 2016 to Office Action dated Sep. 21, 2015”, w/English Claims, 7 pgs.  
 “Chinese Application Serial No. 201480025701.9, Office Action dated Jan. 16, 2018”, (English Translation), 8 pgs.  
 “Chinese Application Serial No. 201480025701.9, Office Action dated Jul. 12, 2017”, W/ English Translation, 8 pgs.  
 “Chinese Application Serial No. 201480025701.9, Office Action dated Jul. 25, 2016”, (With English Translation), 4 pgs.  
 “Chinese Application Serial No. 201480025701.9, Office Action dated Dec. 23, 2016”, W/ English Translation, 39 pgs.  
 “Chinese Application Serial No. 201480025701.9, Office Action dated Dec. 23, 2016”, 24 pgs.  
 “Chinese Application Serial No. 201480025701.9, Response filed Mar. 27, 2018 to Office Action dated Jan. 16, 2018”, w/ English Claims, 20 pgs.  
 “Chinese Application Serial No. 201480025701.9, Response filed Sep. 15, 2017 to Office Action dated Jul. 12, 2017”, w/ English Translation, 21 pgs.  
 “DARCO® FGD—Powdered Activated Carbon”, Norit Americas Inc. Datasheet No. 1100, (May 2009), 1 pg.  
 “Database WPI Week 197450”, Thomson Scientific, London, GB; AN 1974-86199V XP002514926.  
 “European Application Serial No. 05814011.2, Response filed Sep. 9, 2011 to European Search Report dated Apr. 14, 2009 and Office Actioin dated Nov. 5, 2009”, 20 pgs.  
 “European Application Serial No. 05814011.2, Communication Pursuant to Article 94(3) EPC dated Nov. 5, 2009”, 4 pgs.  
 “European Application Serial No. 05814011.2, Decision to grant dated Jun. 8, 2012”, 2 pgs.  
 “European Application Serial No. 05814011.2, Extended European Search Report dated Apr. 14, 2009”, 13 pgs.  
 “European Application Serial No. 05814011.2, Office Action dated Jan. 25, 2008”, 2 pgs.  
 “European Application Serial No. 05814011.2, Office Action dated Jan. 31, 2012”, 4 pgs.  
 “European Application Serial No. 05814011.2, Office Action dated Apr. 27, 2012”, 6 pgs.  
 “European Application Serial No. 05814011.2, Office Action dated Nov. 5, 2009”, 2 pgs.  
 “European Application Serial No. 05814011.2, Partial European Search Report dated Apr. 14, 2009”, 13 pgs.

“European Application Serial No. 05814011.2, Response filed Feb. 28, 2012 to Office Action dated Jan. 31, 2012”, 30 pgs.  
 “European Application Serial No. 05814011.2, Response filed Apr. 18, 2008 to Office Action dated Jan. 25, 2008 and Third Party Observations submitted Dec. 4, 2007”, 7 pgs.  
 “European Application Serial No. 05814011.2, Response filed May 11, 2010 to Communication Pursuant to Article 94(3) EPC dated Nov. 5, 2009”, 11 pgs.  
 “European Application Serial No. 05814011.2, Response filed May 11, 2010 to Office Action dated Nov. 5, 2009”, 11 pgs.  
 “European Application Serial No. 05814011.2, Response filed Sep. 9, 2011 to Extended European Search Report dated Apr. 14, 2009”, 20 pgs.  
 “European Application Serial No. 05814011.2, Third Party Observations submitted Mar. 19, 2012”, 7 pgs.  
 “European Application Serial No. 05814011.2, Third Party Observations submitted Dec. 4, 2007”, 5 pgs.  
 “European Application Serial No. 10767465.7, Decision to grant dated Apr. 17, 2014”, 2 pgs.  
 “European Application Serial No. 10767465.7, Extended European Search Report dated Dec. 6, 2012”, 5 pgs.  
 “European Application Serial No. 10767465.7, Intention to Grant dated Mar. 17, 2014”, 44 pgs.  
 “European Application Serial No. 10767465.7, Intention to Grant dated Sep. 30, 2013”, 44 pgs.  
 “European Application Serial No. 10767465.7, Response filed Feb. 3, 2014 to Intention to Grant dated Sep. 30, 2013”, 11 pgs.  
 “European Application Serial No. 10767465.7, Response filed Jun. 20, 2013 to Extended European Search Report dated Dec. 6, 2012”, 18 pgs.  
 “European Application Serial No. 11189249.3, Communication Pursuant to Article 94(3) EPC dated Nov. 26, 2012”, 4 pgs.  
 “European Application Serial No. 11189249.3, Decision to Refuse dated Dec. 19, 2013”, 18 pgs.  
 “European Application Serial No. 11189249.3, Extended European Search Report dated Feb. 1, 2012”, 7 pgs.  
 “European Application Serial No. 11189249.3, Office Action dated Nov. 4, 2013”, 4 pgs.  
 “European Application Serial No. 11189249.3, Response filed Feb. 4, 2013 to Communication Pursuant to Article 94(3) EPC dated Nov. 26, 2012”, 9 pgs.  
 “European Application Serial No. 11189249.3, Response filed Aug. 28, 2012 to Extended European Search Report dated Feb. 1, 2012”, 9 pgs.  
 “European Application Serial No. 11189249.3, Summons to Attend Oral Proceedings mailed Apr. 15, 2013”, 7 pgs.  
 “European Application Serial No. 11189252.7, Communication Pursuant to Article 94(3) EPC dated Jan. 9, 2013”, 4 pgs.  
 “European Application Serial No. 11189252.7, Decision to grant dated May 2, 2014”, 2 pgs.  
 “European Application Serial No. 11189252.7, Extended European Search Report dated Jan. 23, 2012”, 6 pgs.  
 “European Application Serial No. 11189252.7, Extended European Search Report dated May 9, 2012”, 12 pgs.  
 “European Application Serial No. 11189252.7, Office Action dated Oct. 30, 2013”, 4 pgs.  
 “European Application Serial No. 11189252.7, Office Action dated Dec. 11, 2013”, 6 pgs.  
 “European Application Serial No. 11189252.7, Response filed Feb. 11, 2013 to Communication Pursuant to Article 94(3) EPC dated Jan. 9, 2013”, 5 pgs.  
 “European Application Serial No. 11189252.7, Response filed Oct. 10, 2013 to Office Action dated Apr. 15, 2013”, 18 pgs.  
 “European Application Serial No. 11189252.7, Response filed Nov. 22, 2012 to Extended European Search Report dated May 9, 2012”, 13 pgs.  
 “European Application Serial No. 11189252.7, Summons to Attend Oral Proceedings mailed Apr. 15, 2013”, 6 pgs.  
 “European Application Serial No. 13719338.9, Notification Regarding Rule 164 and Article 94(3) EPC mailed Apr. 24, 2017”, 8 pgs.  
 “European Application Serial No. 13719338.9, Office Action dated May 12, 2017”, 6 pgs.

(56)

## References Cited

## OTHER PUBLICATIONS

“European Application Serial No. 13719338.9, Office Action dated Dec. 19, 2014”, 2 pgs.

“European Application Serial No. 13719338.9, Response filed Jun. 29, 2015 to Office Action dated Dec. 19, 2014”, 19 pgs.

“European Application Serial No. 14711106.6, Communication Pursuant to Article 94(3) EPC dated Feb. 22, 2017”, 6 pgs.

“European Application Serial No. 14711106.6, Response filed Aug. 17, 2017 to Communication Pursuant to Article 94(3) EPC dated Feb. 22, 2017”, 10 pgs.

“International Application No. PCT/US2008/071986, International Search Report dated Jan. 30, 2009”, 3 pgs.

“International Application Serial No. PCT/US2005/030018, International Preliminary Report on Patentability dated Dec. 27, 2006”, 3 pgs.

“International Application Serial No. PCT/US2005/030018, International Search Report dated Jul. 25, 2006”, 2 pgs.

“International Application Serial No. PCT/US2005/030018, Written Opinion dated Jul. 25, 2006”, 3 pgs.

“International Application Serial No. PCT/US2010/022807, International Preliminary Report on Patentability dated Nov. 3, 2011”, 6 pgs.

“International Application Serial No. PCT/US2010/022807, International Search Report dated Sep. 13, 2010”, 3 pgs.

“International Application Serial No. PCT/US2010/022807, Written Opinion dated Sep. 13, 2010”, 4 pgs.

“International Application Serial No. PCT/US2013/036964, International Preliminary Report on Patentability dated Jul. 17, 2014”, 11 pgs.

“International Application Serial No. PCT/US2013/036964, International Search Report dated Nov. 29, 2013”, 7 pgs.

“International Application Serial No. PCT/US2013/036964, Invitation to Pay Additional Fees and Partial Search Report dated Aug. 2, 2013”, 7 pgs.

“International Application Serial No. PCT/US2013/036964, Written Opinion dated Apr. 15, 2014”, 10 pgs.

“International Application Serial No. PCT/US2013/036964, Written Opinion dated Nov. 29, 2013”, 13 pgs.

“International Application Serial No. PCT/US2014/019916, International Search Report dated Oct. 13, 2014”, 6 pgs.

“International Application Serial No. PCT/US2014/019916, Invitation to Pay Additional Fees and Partial Search Report dated May 30, 2014”, 6 pgs.

“International Application Serial No. PCT/US2014/019916, Written Opinion dated Oct. 13, 2014”, 13 pgs.

“Powdered Activated Carbon”, Cabot Corp, [Online] retrieved from the internet: <<http://www.cabotcorp.com/solutions/products-plus/activated-carbon/powdered>>, (Jan. 3, 2015), 3 pgs.

“Response filed Sep. 4, 2017 to Notification Regarding Rule 164 and Article 94(3) EPC dated Apr. 24, 2017”, 7 pgs.

Arenillas, A., et al., “CO<sub>2</sub> removal potential of carbons prepared by co-pyrolysis of sugar and nitrogen containing compounds”, *Journal of analytical and applied pyrolysis* 74.1, (2005), 298-306.

Bakandritsos, A., et al., “Aqueous and Gaseous Adsorption from Montmorillonite-Carbon Composites and from Derived Carbons”, *Langmuir*, 21, (2005), 2349-2355.

Bakandritsos, A., et al., “High Surface Area Montmorillonite—Carbon Composites and Derived Carbons”, *Chemistry of Materials*, vol. 16, No. 8, (Mar. 16, 2004), 1551-1559.

Bimer, Jan, et al., “Modified active carbons from precursors enriched with nitrogen functions: sulfur removal capabilities”, (1998), 519-525.

Chang, Shih-Ger, “Method for Oxidation of Mercury Vapor”, U.S. Appl. No. 60/560,904, filed Apr. 9, 2004, (Apr. 9, 2004), 9 pgs.

Criswell, Gordon, et al., “Progress Report on Mercury Control Retrofit at the Colstrip Power Station”, Paper #91, Mega Symposium, Baltimore, MD, (Aug. 2011), 1-23.

Darder, M., et al., “Caramel-clay nanocomposites”, *Journal of Materials Chemistry*, 15, (2005), 3913-3918.

Diamantopoulou, LR G Skodras, et al., “Sorption of mercury by activated carbon in the presence of flue gas components”, *Fuel Processing Technology* 91.2, (2010), 158-163.

Dong, J., et al., “Mercury Removal from Flue Gases by Novel Regenerable Magnetic Nanocomposite Sorbents”, *Environ. Sci. Technol.*, 43, (2009), 3266-3271.

Dunham, G. E., et al., “Mercury Capture by an Activated Carbon in a Fixed-Bed Bench-Scale System”, *Environmental Progress*, 17(3), (1998), 203-208.

Eisazadeh, H., “Removal of Mercury from Water Using Polypyrrole and its Composites”, *Chinese Journal of Polymer Science*, 25(4), (2007), 393-397.

Felsvang, K., et al., “Mercury Reduction and Control Options”, The U.S. EPA-DOE-EPRI Combined Power Plant Air Pollutant Control Symposium; The Mega Symposium and The A&WMA Specialty Conference and Mercury Emissions: Fate, Effects and Control; Chicago, IL, (Aug. 2001), 1-19.

Fernandez-Saavedra, R., et al., “Polymer-Clay Nanocomposites as Precursors of Nanostructured Carbon Materials for Electrochemical Devices: Templating Effect of Clays”, *Journal of Nanoscience and Nanotechnology*, 8, (2008), 1741-1750.

Ghorbani, M., et al., “Application of polyaniline nanocomposite coated on rice husk ash for removal of Hg(II) from aqueous media”, *Synthetic Metals*, (2001), 4 pgs.

Ghorishi, Behrooz, et al., “Sorption of Mercury Species by Activated Carbons and Calcium-Based Sorbents: Effect of Temperature, Mercury Concentration and Acid Gases”, *Waste Manage. Res.*, 16:6, (1998), 582-593.

Gomez-Aviles, A., et al., “Functionalized Carbon-Silicates from Caramel-Sepiolite Nanocomposites”, *Angew. Chem. Int. Ed.*, 46, (2007), 923-925.

Gomez-Aviles, A., et al., “Multifunctional materials based on graphene-like/sepiolite nanocomposites”, *Applied Clay Science*, 47, (2010), 203-211.

Ha, et al., “Effect of unburnt carbon on the corrosion performance of fly ash cement mortar”, *Construction and Building Materials*, (Sep. 1, 2005), 7 pgs.

Ikeue, K., et al., “Noble-metal-containing nanoporous carbon synthesized within the interlayer space of montmorillonite and its catalytic property”, *Applied Catalysis A: General*, 351, (2008), 68-74.

Kawabuchi, Yuji, et al., “Chemical vapor deposition of heterocyclic compounds over active carbon fiber to control its porosity and surface function”, *Langmuir* 13.8, (1997), 2314-2317.

Kyotani, T., et al., “Formation of highly orientated graphite from polyacrylonitrile by using a two-dimensional space between montmorillonite lamellae”, *Nature*, 331, (1988), 331-333.

Lancia, A., et al., “Adsorption of Mercuric Chloride Vapours from Incinerator Flue Gases on Calcium Hydroxide Particles”, *Combust. Sci. & Tech.*, 93, (1993), 277-289.

Laumb, Jason D., et al., “X-ray photoelectron spectroscopy analysis of mercury sorbent surface chemistry”, *Fuel Processing Technology*, 85, (2004), 577-585.

Li, Y., et al., “Removal of elemental mercury from simulated coal-combustion flue gas using a SiO<sub>2</sub>—TiO<sub>2</sub> nanocomposite”, *Fuel Processing Technology*, 89, (2008), 567-573.

M, Hocquel, “Quecksilber und seine Verbindungen bei der Abfallverbrennung”, with English Abstract p. 3, (Dec. 31, 2000), 112 pgs.

Maroto-Valer, M. Mercedes, et al., “Development of Activated Carbons From Coal and Biomass Combustion and Gasification Chars”, (2004), 2 pgs.

Mochida, I., et al., “Preparation of nitrogen containing pitches from quinoline and isoquinoline by AID of AlCl<sub>3</sub>”, *Carbon*, 33(8), (1995), 1069-1077.

Nguyen-Thanh, D., et al., “High Porosity Carbonaceous Adsorbents Templated From Porous Clay Heterostructures”, *Prepr. Pap.-Am. Chem. Soc., Div. Fuel Chem.*, 51(1), (2006), 7-8.

Nguyen-Thanh, D., et al., “Metal-loaded carbonaceous adsorbents templated from porous clay heterostructures”, *Microporous and Mesoporous Materials*, 92, (2006), 47-55.

(56)

**References Cited**

## OTHER PUBLICATIONS

- Nickels, Dale L, et al., "Processing and reuse of activated carbon used to adsorb mercury from power plant flue gases", Final report, (2004).
- Olson, David, et al., "The reduction of gas phase air toxics from combustion and incineration sources using the MET-Mitsui-BF activated coke process", Fuel Processing Technology, (2000), 13 pgs.
- Olson, David G., et al., "The Reduction of Gas Phase Air Toxics from Combustion and Incineration Sources using the MET-Mitsui-BF Activated Coke Process", Fuel Processing Technology, 65-66, (2000), 393-405.
- Olson, E. S., et al., "Catalytic effects of carbon sorbents for mercury capture", Journal of Hazardous Materials, 74, (2000), 61-79.
- Olson, Edwin S., et al., "Surface Compositions of Carbon Sorbents Exposed to Simulated Low-Rank Coal Flue Gases", J. Air & Water Waste Manage. Assoc., 55, (2005), 747-754.
- Padak, Bihter, "Understanding mercury binding on activated carbon", Carbon 47.1 2, (2009), 2855-2864.
- Przepiorski, J, et al., "High temperature ammonia treatment of activated carbon for enhancement of CO2 adsorption", Applied Surface Science 225.1, (2004), 235-242.
- Rachel, Ribeirovieira Azzi Rios, et al., "Tailoring Activated Carbon by Surface Chemical Modification with O, S, and N Containing Molecules", Materials Research. 6 (2), (2003), 129-135.
- Raymundo-Pinero, E, et al., "Structural characterization of N-containing activated carbon fibers prepared from a low softening point petroleum pitch and a melamine resin", Carbon 40.4, (2002), 597-608.
- Smokey, et al., "Alternative to Activated Carbon for Mercury Control", Power Engineering, (Oct. 2012), 10 pgs.
- Streng, Sabine, et al., "Toxics control by activated charcoal within the "System Dusseldorf" full scale experience", B. Fuel Processing Technology, (1994), 14 pgs.
- Tsuji, K, et al., "The Activated Coke Process for Combined SOx/NOx/Air Toxics Reduction", Air and Water Management Assoc., (Mar. 10, 1993), 27 pgs.
- Vosteen, B, et al., "Chlor- und Bromgestutzte Hg-Sorption an Elektrofilter-Flugaschen eines kohlegefeuerten Schmelzkammerkessels und an Zementrohmehl", Matin-Luther-Universitat Halle-Wittenberg, (2003), 1-30.
- Vosteen, B. W., et al., "Flyer on Mercury Abatement given at the VDI—Wissensforum, Dusseldorf, Germany, (2003), 6 pgs.
- Vosteen, B. W., "Bromine-enhanced Mercury Abatement from Combustion Flue Gases—Recent Industrial Applications and Laboratory Research", VGB PowerTech, vol. 86, Issue Mar. 2006, (2006), 70-75.
- Vosteen, N., "Emissionsminderung von Quecksilber durch chlor- und bromgestutzte Hg-Oxidation in Rauchgas", (Sep. 2003), 1-23.
- Wan, Q., et al., "Removal of gaseous elemental mercury over a CeO<sub>2</sub>—WO<sub>3</sub>/TiO<sub>2</sub> nanocomposite in simulated coal-fired flue gas", Chemical Engineering Journal, 170, (2011), 512-517.
- Wang, B., et al., "Performance of a diatomite-based sorbent in removing mercury from aqueous and oil matrices", J. Environ. Eng. Sci., 6, (2007), 469-476.
- Zhang, Y., et al., "High efficient removal of mercury from aqueous solution by polyaniline/humic acid nanocomposite", Journal of Hazardous Materials, 175, (2010), 404-409.
- Zhao, Yongxin, et al., "Effectsof Sulfur Dioxide and Nitric Oxide on Mercury Oxidation and Reducton under Homogeneous Conditions", J. Air & Waste Manage. Assoc., 56, (2006), 628-635.
- Zheng, Yuanjing, et al., "Review of technologies for mercury removal from flue gas from cement production processes", Progress in Energy and Combustion Science, vol. 38, No. 5, (Apr. 26, 2012), 599-629.
- Zhu, Jianzhong, et al., "Enhanced mercury ion adsorption by amine-modified activated carbon", Journal of hazardous materials 166, (2009), 866-872.
- "U.S. Appl. No. 14/712,558, Non Final Office Action dated Jul. 2, 2018", 16 pgs.
- "U.S. Appl. No. 14/712,558, Supplemental Amendment filed Jun. 13, 2018", 14 pgs.
- "U.S. Appl. No. 15/974,343 Preliminary Amendment Filed May 15, 2018", 7 pgs.
- "U.S. Appl. No. 15/295,594, Response filed Jul. 3, 2018 to Restriction Requirement dated May 22, 2018", 9 pgs.
- "U.S. Appl. No. 15/295,594, Restriction Requirement dated May 22, 2018", 6 pgs.
- "U.S. Appl. No. 15/295,594, Restriction Requirement dated Jun. 29, 2018", 5 pgs.
- "U.S. Appl. No. 15/295,594, Supplemental Amendment Filed May 15, 2018", 10 pgs.
- "U.S. Appl. No. 15/589,359, Final Office Action dated Jun. 4, 2018", 13 pgs.
- "U.S. Appl. No. 15/589,359, Response filed May 18, 2018 to Non Final Office Action dated Feb. 21, 2018", 14 pgs.
- "Supplementary European Search Report, dated Dec. 6, 2012", 2 pgs.
- "U.S. Appl. No. 15/295,594, Response filed Jul. 24, 2018 to Restriction Requirement dated Jun. 29, 2018", 9 pgs.
- "U.S. Appl. No. 15/449,112, Notice of Allowance dated Jul. 12, 2018", 8 pgs.
- "U.S. Appl. No. 15/589,359, Response filed Jul. 26, 2018 to Non Final Office Action dated Jun. 4, 2018", 14 pgs.
- "U.S. Appl. No. 15/974,343, Non Final Office Action dated Jul. 27, 2018", 12 pgs.
- "U.S. Appl. No. 15/997,091, Non Final Office Action dated Jul. 27, 2018", 13 pgs.
- "U.S. Appl. No. 15/997,091, Response filed Aug. 14, 2018 to Non Final Office Action dated Jul. 27, 2018", 10 pgs.
- "European Application Serial No. 14711106.6, Office Action dated Jun. 5, 2018", 16 pgs.
- "U.S. Appl. No. 15/974,343, Response filed Aug. 14, 2018 to Non Final Office Action dated Jul. 27, 2018", 11 pgs.
- "U.S. Appl. No. 14/712,558, Response filed Aug. 14, 2018 to Non Final Office Action dated Jul. 2, 2018", 11 pgs.
- "U.S. Appl. No. 15/382,114, Restriction Requirement dated Aug. 28, 2018", 9 pgs.
- "U.S. Appl. No. 15/589,359, Final Office Action dated Sep. 12, 2018", 14 pgs.
- "U.S. Appl. No. 15/382,114, Response filed Sep. 12, 2018 to Restriction Requirement dated Aug. 28, 2018", 8 pgs.
- "U.S. Appl. No. 15/589,359, Response filed Sep. 14, 2018 to Final Office Action dated Sep. 12, 2018", 18 pgs.
- "U.S. Appl. No. 14/712,558, Non Final Office Action dated Oct. 19, 2018", 26 pgs.
- "U.S. Appl. No. 14/712,558, Non-Final Office Action dated Oct. 19, 2018", 35 pgs.
- "U.S. Appl. No. 15/295,594, Non Final Office Action dated Oct. 23, 2018", 20 pgs.
- "U.S. Appl. No. 15/589,359, Non Final Office Action dated Oct. 22, 2018", 12 pgs.
- "U.S. Appl. No. 15/974,343, Non Final Office Action dated Oct. 29, 2018", 22 pgs.
- "U.S. Appl. No. 15/997,091, Non Final Office Action dated Nov. 2, 2018", 27 pgs.
- "European Application Serial No. 14711106.6, Response filed Oct. 15, 2018 to Office Action dated Jun. 5, 2018", w/ English Claims, 15 pgs.
- Pietrzak, et al., "Preparation of nitrogen-enriched activated carbons from brown coal", Energy and Fuels 20.3, (2006), 1275-1280.
- "U.S. Appl. No. 14/712,558, Amendment and Response filed Dec. 3, 2018 to Non Final Office Action dated Oct. 19, 2018", 28 pgs.
- "U.S. Appl. No. 14/712,558, Final Office Action dated Jan. 11, 2019", 27 pgs.
- "U.S. Appl. No. 15/382,114, Non Final Office Action dated Dec. 12, 2018", 46 pgs.
- "U.S. Appl. No. 15/589,359, Amendment and Response filed Jan. 17, 2019 to Non Final Office Action dated Oct. 22, 2018", 14 pgs.
- "U.S. Appl. No. 15/974,343, Amendment and Response filed Dec. 3, 2018 to Non Final Office Action dated Oct. 29, 2018", 37 pgs.
- "U.S. Appl. No. 15/974,343, Final Office Action dated Jan. 14, 2019", 25 pgs.

(56)

**References Cited**

## OTHER PUBLICATIONS

“U.S. Appl. No. 15/997,091, Final Office Action dated Jan. 11, 2019”, 20 pgs.

“U.S. Appl. No. 15/997,091, Response filed Dec. 3, 2018 Non Final Office Action dated Nov. 2, 2018”, 40 pgs.

“Canadian Application Serial No. 2,904,039, Office Action dated Feb. 18, 2019”, 6 pgs.

“U.S. Appl. No. 15/382,114, Response filed Mar. 12, 2019 to Non Final Office Action dated Dec. 12, 2018”, 24 pgs.

“U.S. Appl. No. 15/589,359, Final Office Action dated Mar. 1, 2019”, 10 pgs.

et al., “Coal Combustion Products (CCPs): Characteristics, Utilization and Beneficiation”, Edited by Tom Robl, et al., Woodhead Publishing (Elsevier), (2017), 565 pgs.

“Control of Mercury Emissions from Coal Fired Electric Utility Boilers: An Update”, US EPA Air Pollution Prevention and Control Division, National Risk Management Research Laboratory, Office of Research and Development, (Feb. 18, 2005), 59 pgs.

“Sorbent Enhancement Additives for Mercury Control”, US DOE Office of Fossil Energy, National Energy Technology Laboratory, (Jun. 2008), 4 pgs.

Benson, Steven A., et al., “JV Task 73—Mercury Control Technologies for Electric Utilities Burning Subbituminous Coals—Draft Final Report”, University of North Dakota Energy and Environmental Research Center, (Jun. 2005), 165 pgs.

Benson, Steven A., et al., “Pilot-and Full-Scale Demonstration of Advanced Mercury Control Technologies for Lignite-Fired Power Plants”, University of North Dakota Energy and Environmental Research Center, (Feb. 2005), 97 pgs.

Berry, Mark, et al., “Mercury control evaluation of calcium bromide injection into a PRB-fired furnace with an SCR”, Proc. of the Air Quality VI Conference, Arlington, VA, (2007), 9 pgs.

Brown, Thomas D., et al., “Mercury Measurement and Its Control: What We Know, Have Learned, and Need to Further Investigate”, Journal of the Air and Waste Management Association, 49(6), (Jun. 1999), 98 pgs.

Feeley, Thomas J., et al., “A Review of DOE/NETL’s Mercury Control Technology R and D Program for Coal-Fired Power Plants”, DOE/NETL Hg R and D Program Review, (Apr. 2003), 32 pgs.

French, Charles L., et al., “Study of Hazardous Air Pollutant Emissions from Electric Utility Steam Generating Units—Final Report to Congress: vol. 1”, US EPA Office of Air Quality Planning and Standards, (Feb. 1998), 502 pgs.

Ghorishi, Behrooz S., et al., “In-Flight Capture of Elemental Mercury by Chlorine-Impregnated Activated Carbon”, Proc. of the 94th Annual Meeting of the Air and Waste Management Association, Orlando, FL, (Jun. 2001), 14 pgs.

Jones, Andrew P., et al., “DOE/NETL’s Phase II Mercury Control Technology Field Testing Program: Preliminary Economic Analysis of Activated Carbon Injection”, Environmental Science and Technology, 41(4), (2007), 7 pgs.

Keating, Martha H., et al., “Mercury Study Report to Congress vol. 1: Executive Summary”, US EPA Office of Air Quality Planning and Standards, (Dec. 1997), 95 pgs.

Kilgroe, James D., et al., “Control of Mercury Emissions from Coal-Fired Electric Utility Boilers: Interim Report”, US EPA Office of Research and Development, National Risk Management Laboratory, Air Pollution Prevention and Control Division, (Dec. 2001), 485 pgs.

Nelson, Sid Jr., et al., “How China Can Leapfrog the World in Mercury Emission Reductions”, Proc. of the AWMA Intl. Specialty Conference on Leapfrogging Opportunities for Air Quality Improvement, (2010), 24 pgs.

Pavlish, John H., et al., “Status review of mercury control options for coal-fired power plants”, Fuel Processing Technology, vol. 82, (2003), 77 pgs.

Yang, Yang, et al., “Effect of HBr formation on mercury oxidation via CaBr<sub>2</sub> addition to coal during combustion”, RSC Advances, 6(64), 2016, 7 pgs.

\* cited by examiner

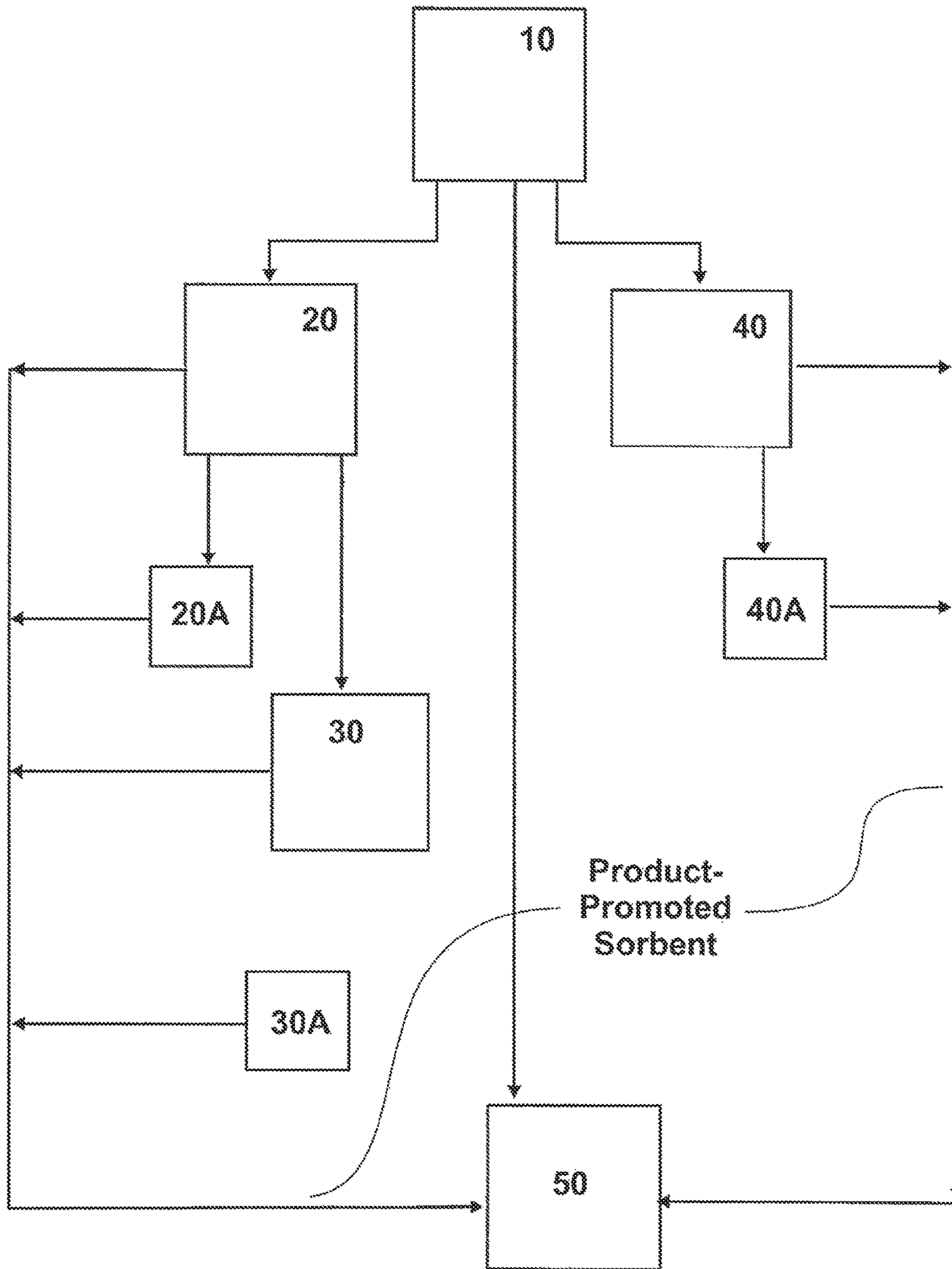

FIG. 1

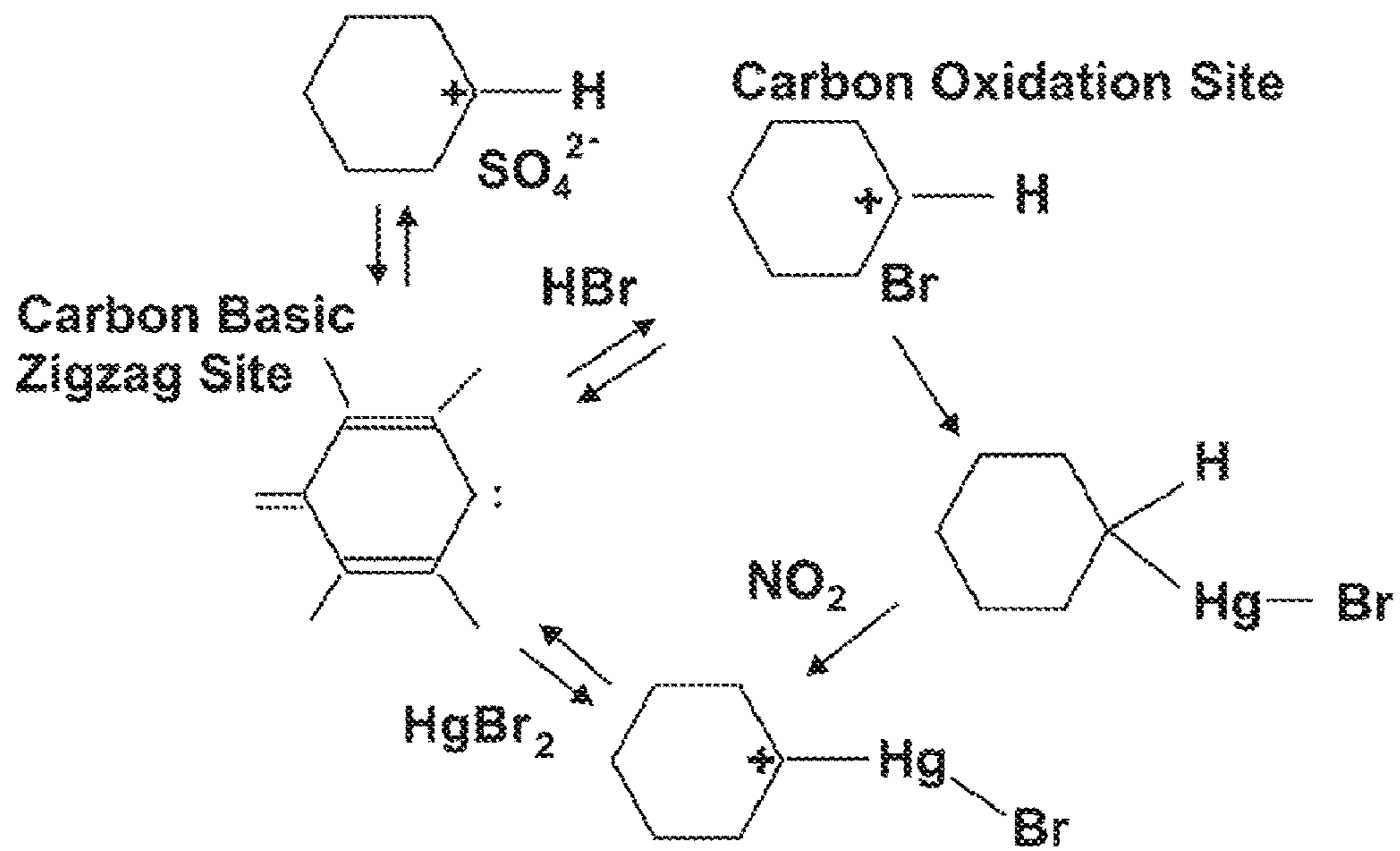

FIG. 2

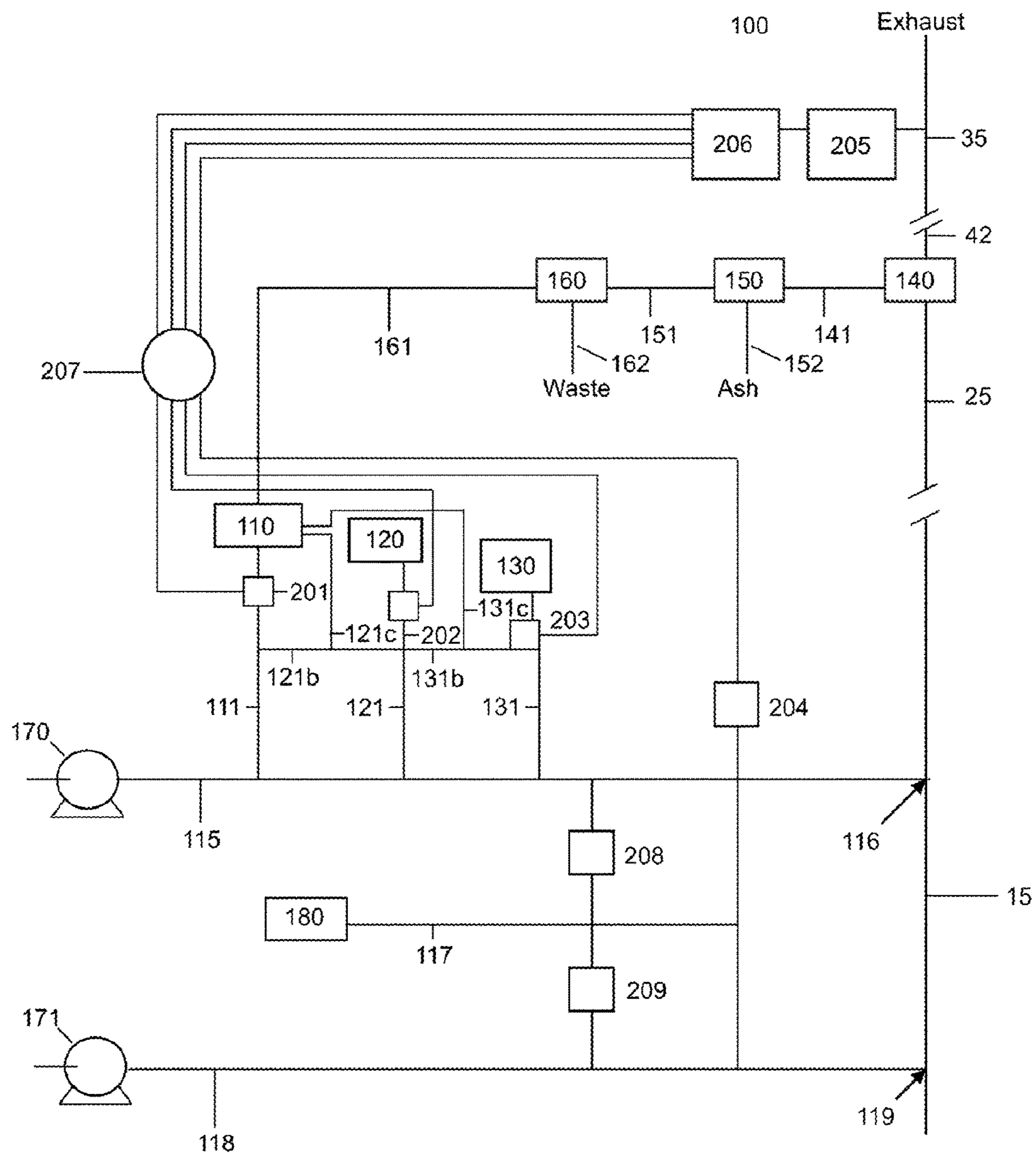

FIG. 3

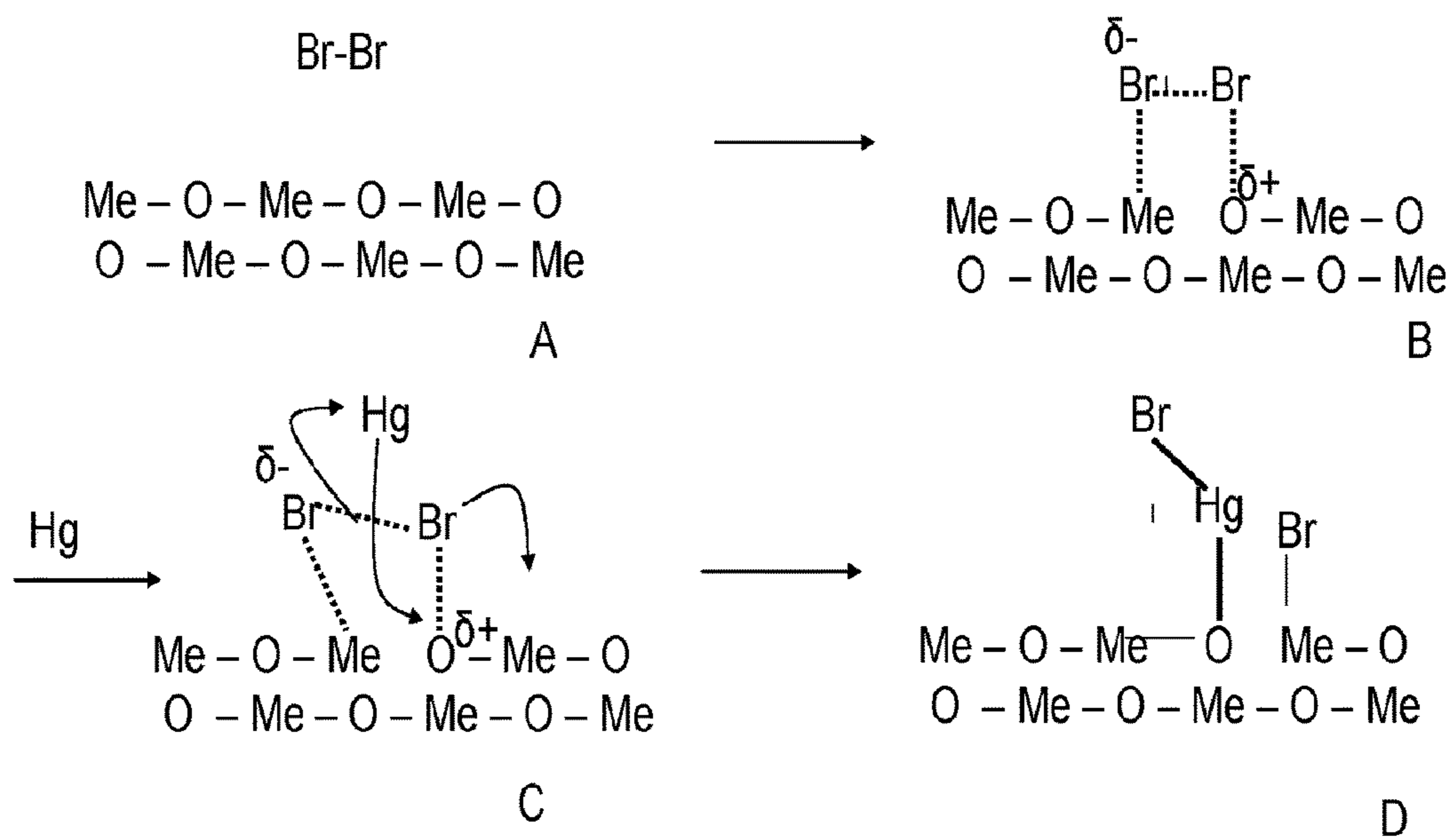

FIG. 4

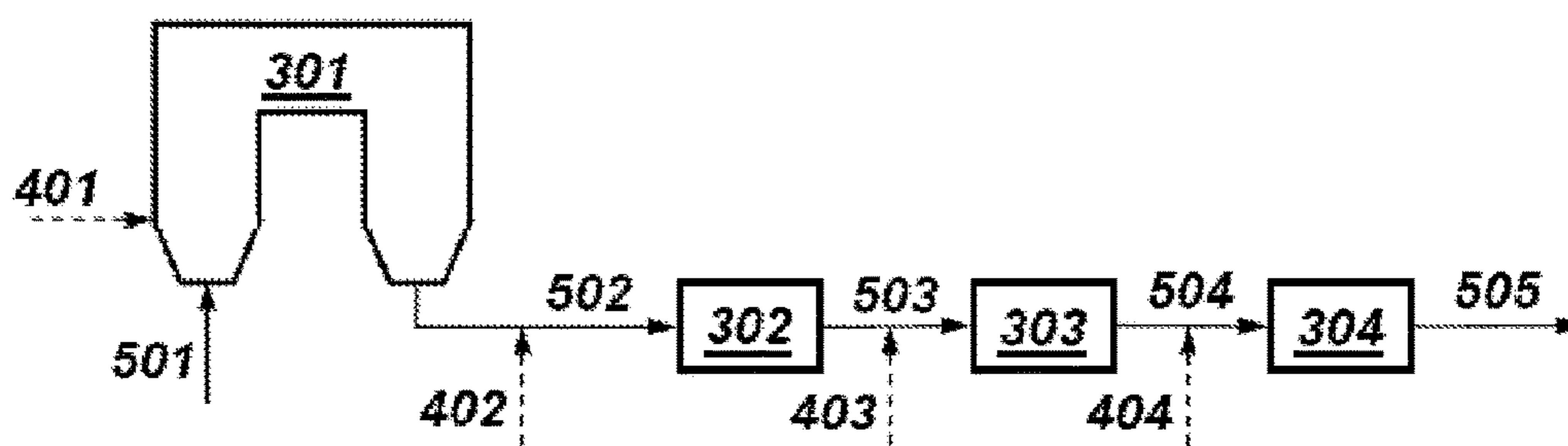

FIG. 5A

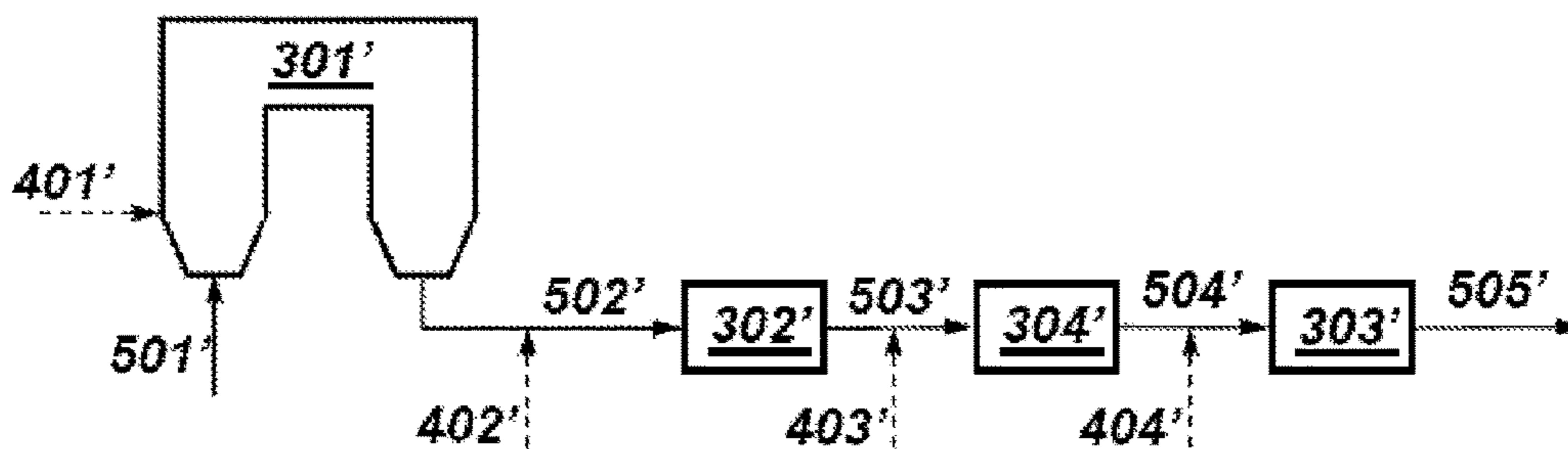

FIG. 5B

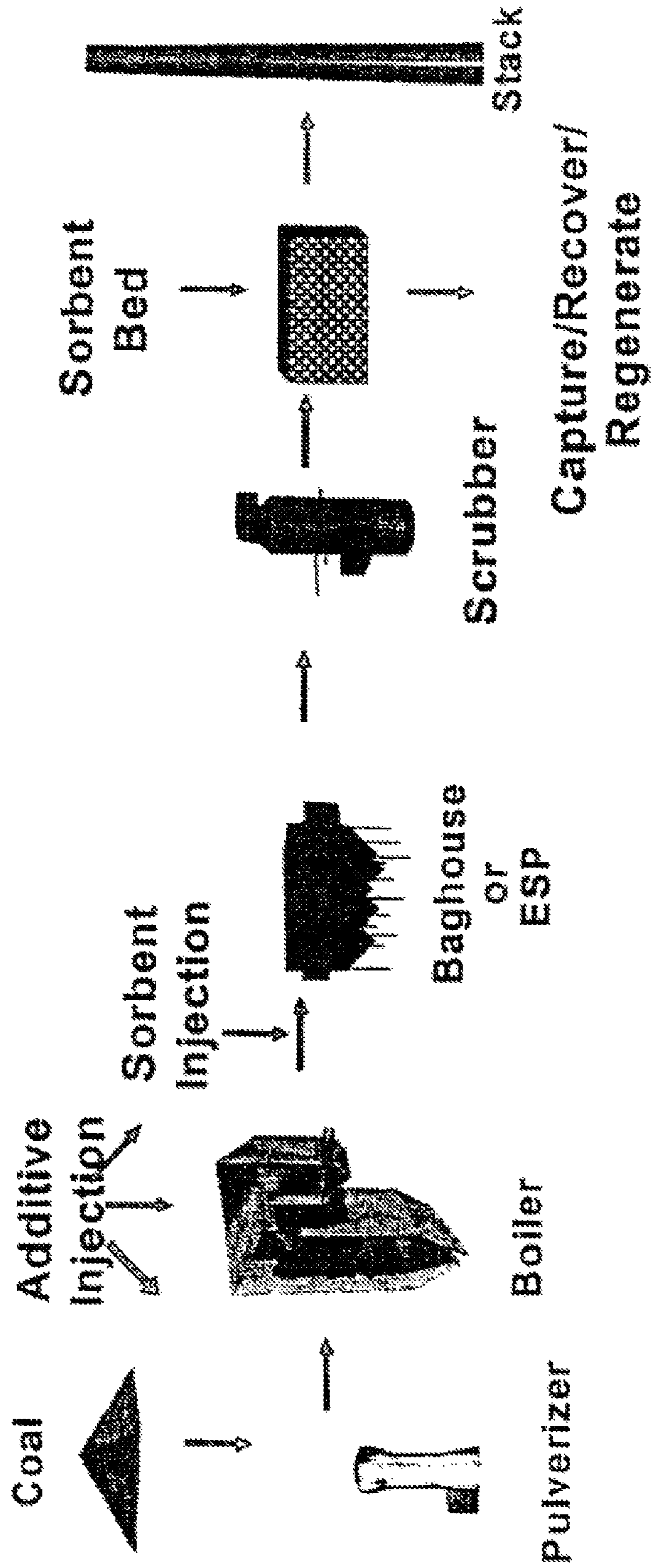

FIG. 6

1

## SORBENTS FOR THE OXIDATION AND REMOVAL OF MERCURY

### CROSS-REFERENCE TO RELATED APPLICATIONS

This application is a continuation-in-part of U.S. patent application Ser. No. 15/295,594, filed Oct. 17, 2016, which is a continuation of U.S. patent application Ser. No. 14/102,896 filed on Dec. 11, 2013 (now U.S. Pat. No. 9,468,886), which is a continuation of U.S. patent application Ser. No. 12/429,058 filed on Apr. 23, 2009 (now U.S. Pat. No. 8,652,235), which is a continuation-in-part of U.S. patent application Ser. No. 12/201,595 filed on Aug. 29, 2008 (abandoned), which is a divisional of U.S. patent application Ser. No. 11/209,163 filed on Aug. 22, 2005 (now U.S. Pat. No. 7,435,286), which claims priority from provisional application Ser. No. 60/605,640 filed on Aug. 30, 2004. The disclosures of U.S. patent application Ser. Nos. 14/102,896; 12/429,058; 12/201,595; 11/209,163; and 60/605,640 are hereby incorporated herein by reference to the extent appropriate.

### BACKGROUND OF THE INVENTION

#### Technical Field of the Invention

The present invention relates to methods and materials for the removal of pollutants from flue gas or product gas from a gasification system. In particular, mercury is removed from gas streams generated during the burning or gasification of fossil fuels by highly reactive regenerable sorbents.

#### Background of the Invention

The combustion and gasification of fossil fuel such as coal generates flue gas that contains mercury and other trace elements that originate from the fuel. The release of the mercury (and other pollutants) to the environment must be controlled by use of sorbents, scrubbers, filters, precipitators, and other removal technologies. Mercury is initially present in the elemental form during combustion and gasification. In downstream process sections, such as in the ducts and stack of a combustion system, some of the elemental mercury is oxidized. The amount that is oxidized depends on the amount of acid gases present in the flue gas and other factors. Amounts of mercury vary with the fuel, but concentrations of mercury in the stream of flue gas from coal combustion are typically less than 5 parts per billion (ppb). Large coal combustion facilities such as electric utilities may emit a pound of mercury, or more, a day. Mercury removal applications include, without limitation, flue gas from coal (or other fossil fuel) combustion, waste incineration, product gas from gasification, as well as off-gases from mineral processing, metal refining, retorting, cement manufacturing, chloralkali plants, dental facilities, and crematories.

#### Mercury Sorbent Technologies

Several types of mercury control methods for flue gas have been investigated, including injection of fine sorbent particles into a flue gas duct and passing the flue gas through a sorbent bed. Fine-particle injection sorbents include activated carbon, metal oxide sorbent, sodium sulfide particles, and basic silicate or oxide sorbents. When particle injection is employed, the mercury captured on the sorbent particles is removed from the gas stream in a particulate control device such as a baghouse or electrostatic precipitator (ESP) and collected along with ash particulate. The sulfide and basic silicate and oxide particles are effective only for the oxidized mercury, and the metal oxide sorbents exhibit

2

slower capture kinetics than the carbon particles. Additionally, injection of fine carbon particles into the flue gas stream has been only partially successful in removing mercury, especially elemental mercury, where effective removal of only about 60% is attained for some applications with a FF (fabric filter) to collect carbon and ash. Even lower removal rates have been observed when an ESP is used to collect the carbon because the contact time of the carbon with the gas is very short.

A major problem with existing carbon injection systems is that the sorbent is relatively unreactive toward mercury. Consequently, these sorbents must be used in large amounts, at high sorbent-to-mercury ratios, to effectively capture the mercury. These sorbents tend to be relatively expensive and cannot be easily separated from the ash for regeneration and reuse. The collection of carbon in the ash also creates solid waste disposal problems, and the spent sorbent may contaminate the collected ash, preventing its use in various applications.

One solution has been to add an oxidative sorbent comprising an aluminosilicate material impregnated with a very heavy dosage of one or more oxidative metal halides plus activated carbon. For example, refer to Varma et al. (20070140940). However, the amounts of metal salts required for Hg oxidation are generally relatively large and expensive. Also, several of the salts that can be used in such a process are highly toxic. Although the metal salts are present for oxidation in this process, activated carbon is essential for getting adsorption of the Hg. As such, there is no synergistic role for the aluminosilicates as they appear to be only a support for the oxidizing salts.

Another approach has been the injection of aluminosilicate particulate such as bentonite, which contains neither oxidizing salts nor halogen complexes with a Lewis base site, and thus lacks the more powerful oxidizing capability of the said complexes as described in this application. For example, see U.S. Pat. No. 7,413,719. Additionally, the injection of an aluminosilicate (kaolin or metakaolin) containing calcium hypochlorite which thermally decomposes to form halogen is also known. For example, see U.S. Patent Application No. 20030103882. Thus these and similar impregnated aluminosilicate technologies require time in flight at appropriate high temperatures to heat the impregnated salt(s) to generate an oxidation site. This clearly represents a kinetic barrier to activation in contrast to the extremely fast complexing reaction of the Lewis acid on the surface of the appropriate Lewis base sorbent described in the present patent. The kinetic barrier is only for heating up the calcium hypochlorite to decompose it to Cl atoms or molecules. Halogen (bimolecular or atomic) would complex with carbon or noncarbon at any lower temperature to form reactive oxidation sites. Also, halide would require a very high temp or strong acid to form reactive halogen or halogen complex.

Yet another approach is the injection of bentonite plus a metal sulfide and a metal salt, none of which is oxidizing to elemental mercury and would require a slow thermal activation step. For example, see U.S. Patent Application No. 20070119300.

The injection of halogen or halogen precursors in a hot zone, followed by contact with an alkaline material in a wet or dry scrubber is another approach known in the art. With such an approach, elemental mercury is claimed to be oxidized by the halogen to Hg(II) which is collected by the alkaline material in the scrubber. For example, see U.S. Pat. No. 6,808,692 (Oehr), U.S. Pat. No. 3,849,267 (Hilgen), U.S. Pat. No. 5,435,980 (Felsvang), U.S. Pat. No. 6,375,909

(Dangtran), U.S. Patent Application No. 20020114749 (Cole), U.S. Pat. No. 6,638,485 (Iida), U.S. Patent Application No. 20030185718 (Sellakumar), U.S. Patent Application No. 20030147793 (Breen), and U.S. Pat. No. 6,878,358 (Vosteen). However, even though it is known to inject halogen forms at some stage of the combustion process, such a process does not utilize a complexing method on a sorbent surface for conducting the oxidation and capture. Further, the alkaline material is rapidly surface-coated by the large concentrations of acid gases, lowering its capacity for adsorption of Hg(II). It is also recognized that the halogen forms initially introduced or generated are far more reactive to the large concentrations of SO<sub>2</sub> and moisture in the flue gas, and so gas-phase reactions of the halogens with Hg are hindered. In contrast, the present invention takes advantage of the Lewis acid complexes that rapidly form on the sorbent surface to effect the Hg oxidation, rather than rely on gas phase reactions for oxidation. Thus HCl, HBr, SO<sub>2</sub>Br, and other gas-phase products all festoon the surface and promote the activity of the sorbent by forming complexes with the sorbent to form a promoted sorbent.

Accordingly, there remains a need for more economical and effective mercury removal technology. This invention provides for cost-effective removal of pollutants, including mercury, using sorbent enhancement additives and/or highly reactive sorbents, with contact times of seconds (or less), and that may be regenerated and reused.

#### SUMMARY

The various embodiments of the present invention overcome the various aspects of the deficiencies of the prior art and provide new and economical methods for the removal of mercury from the gases produced in the utilization of fossil fuels.

A halogen/halide-promoted sorbent is described that is highly effective for the removal of mercury from flue gas streams. The sorbent comprises any activated carbon and/or non-carbon compound, such as porous or vesicular felsic or basaltic materials, clay-based compounds, alkaline compounds, calcium hydroxide compounds, sodium acetate compounds, and/or bicarbonate compounds, or a combination thereof. Optional secondary components and alkali may be added to further increase reactivity and mercury capacity. Mercury removal efficiencies obtained exceed or match conventional methods with added benefits such as reduced costs. Optionally, the promoted sorbent can be regenerated and reused. Sorbent treatment and/or preparation methods are also described. Methods for in-flight preparation, introduction, and control of the sorbent, promoter and promoted sorbent into the mercury contaminated gas stream are described.

When a promoted or a non-promoted base sorbent reacts with elemental or oxidized mercury, a mercury/sorbent chemical composition is formed and, in the case of elemental mercury reacting with the promoted base sorbent, the mercury is oxidized. As discussed in further detail in other portions of the specification, the base sorbent may be either a carbon or a non-carbon material or a combination thereof. Additionally, the mercury/sorbent chemical composition may be comprised of covalent bonds, ionic bonds and/or chemical complexes between the promoted or non-promoted base sorbent and the oxidized mercury. The Lewis basic groups on the non-promoted base sorbent, or the non-promoted portions of a promoted base sorbent, are available for reaction with the Lewis acid groups of already existing oxidized mercury in the mercury containing gas. Thus,

mercury may be removed from the mercury containing gas stream through the formation of multiple and various mercury/sorbent chemical compositions even within the same process. For example, multiple sites on a sorbent particulate can form multiple and various mercury/sorbent chemical compositions in the case where only a portion of the sites on the base sorbent particulate are promoted.

In some embodiments, a carbon and/or non-carbon promoted sorbent and/or a combination thereof is provided comprising a sorbent structure that has reacted with a promoter selected from the group consisting of halides, halogens, and combinations thereof, such that the reaction product is effective for the removal of mercury from a gas stream. The carbon sorbent comprises reactive Lewis acid groups/sites; the non-carbon sorbent comprises reactive Lewis basic groups/sites.

In an embodiment, a promoted carbon and/or non-carbon sorbent is provided wherein the base sorbent is selected from the group consisting of carbon, activated carbon, porous or vesicular felsic and basaltic materials, clay-based compounds, alkaline compounds, calcium hydroxide compounds, sodium acetate compounds, and/or bicarbonate compounds, or a combination thereof, with an average particle size similar to that of fly ash produced from a thermal process (combustion or gasification) or greater than that of fly ash produced such that it is physically separable therefrom, and combinations thereof, and the promoter is selected from the group consisting of molecular halogens, Group V (CAS nomenclature is used throughout) halides, Group VI halides, hydrohalides, and combinations thereof. In an embodiment, the promoted sorbent (carbon, non-carbon, or their combination) may have a mass mean particle diameter such that it can be substantially separated by physical means from entrained ash in the gas stream from which mercury is to be removed. In an embodiment, the base sorbent (carbon, non-carbon, or their combination) may have a mass mean particle diameter greater than about 40 micrometers.

In another embodiment, the promoted sorbent comprises from about 1 to about 30 grams of promoter per 100 grams of base sorbent. Another embodiment further comprises an optional secondary component comprising a halogen or a hydrohalide such that the reactivity and mercury capacity of the promoted sorbent are enhanced.

In another embodiment, the concentration of the optional secondary component on the finished sorbent is within the range of from about 1 to about 15 wt % of the concentration of the promoter on the finished sorbent.

In another embodiment, an optional alkali component may preferably be added to provide a synergistic effect through combination of this alkali with the base sorbent.

In another embodiment, the optional secondary component is selected from the group consisting of Group V halides, Group VI halides, HI, HBr, HCl, and combinations thereof. In another embodiment, the promoter is substantially in vapor form when combined with the base sorbent. In another embodiment, the promoter is combined with an organic solvent prior to reaction with the base sorbent. In another embodiment, the promoter and optional secondary component are combined with the base sorbentsubstantially simultaneously. Another embodiment further comprises adding a mercury-stabilizing reagent selected from the group consisting of S, Se, H<sub>2</sub>S, SO<sub>2</sub>, H<sub>2</sub>Se, SeO<sub>2</sub>, CS<sub>2</sub>, P<sub>2</sub>S<sub>5</sub>, and combinations thereof. Another embodiment further comprises adding an optional alkali component.

In an embodiment, a method is provided comprising providing a granular base sorbent and reacting the base

5

sorbent with a promoter selected from the group consisting of halogens, halides, and combinations thereof, such that the reaction product comprises a promoted sorbent effective for removal of mercury from a gas stream. In a further embodiment, the reaction product comprises from about 1 to about 30 grams of promoter per 100 grams of base sorbent. In another embodiment the reaction product has an average particle-size distribution greater than the average size of entrained ash particles in the gas stream from which mercury is to be removed, such that the reaction product can be substantially removed from the entrained ash particles by physical means. In another embodiment, the reaction product has a mass mean particle diameter greater than about 40 micrometers.

In another embodiment, the promoter is selected from the group consisting of molecular halogens, hydrohalides, Group V halides, Group VI halides, and combinations thereof. In another embodiment, the promoter is in the gas phase when contacting the base sorbent (carbon, non-carbon, or their combination). In another embodiment, the promoter is in an organic solvent when contacting the base sorbent (carbon, non-carbon, or their combination).

In another embodiment, the promoter is selected from the group consisting of Br<sub>2</sub>, a Group V bromide, a Group VI bromide, and combinations thereof.

In another embodiment, the method further comprises reacting the granular non-carbon with an optional secondary component comprising a halogen or a hydrohalide such that the reactivity and mercury capacity of the promoted sorbent are enhanced. In another embodiment, the promoter and optional secondary component are contacted simultaneously with the non-carbon base sorbent. In another embodiment, the method further comprises adding a mercury-stabilizing reagent selected from the group consisting of S, Se, H<sub>2</sub>S, SO<sub>2</sub>, H<sub>2</sub>Se, SeO<sub>2</sub>, CS<sub>2</sub>, P<sub>2</sub>S<sub>5</sub>, and combinations thereof. In an embodiment, a method is provided for control of mercury in a flue gas with substantially lower sorbent requirements. Through enhanced sorbent reactivity, mercury removal per gram of sorbent is increased, thereby decreasing the capital and operating costs by decreasing sorbent requirements.

In an embodiment, the promoted sorbent is introduced by direct injection into the flue gas stream. In another embodiment, the base sorbent is promoted within the flue gas stream.

In an embodiment, a method is provided for reducing mercury in flue gas comprising providing a base sorbent, either by injection or in situ creation, into a mercury-containing flue gas stream, collecting greater than 70 wt % of the mercury in the flue gas on the promoted sorbent to produce a cleaned flue gas, and substantially recovering the promoted sorbent from the cleaned flue gas. In embodiments where less than 70 wt % mercury removal is desired, the required removal is attained using less base sorbent as would be required with standard base sorbent. In a further embodiment, the method further comprises monitoring the mercury content of the clean flue gas, regenerating the recovered promoted sorbent, and using the monitored mercury content of the cleaned flue gas to control the rate of base sorbent and promoter. In another embodiment the injected promoted sorbent is prepared in-flight by reacting a base sorbent (carbon, non-carbon, or their combination) and a promoter within a pneumatic transport line from which the reaction product is injected to the mercury-containing flue gas stream.

In another embodiment, the promoter is selected from the group consisting of molecular halogens, halides, and combinations thereof. In another embodiment, the promoter is reacted in the gas phase or as a vapor. In another embodi-

6

ment, the promoter is added at from about 1 to about 30 grams per 100 grams of the base sorbent (carbon, non-carbon, or their combination).

In another embodiment, the injected promoted sorbent is prepared in-flight by reacting a base sorbent (carbon, non-carbon, or their combination), a promoter, and an optional secondary component to enhance the reactivity and capacity of the promoted sorbent within a pneumatic transport line from which the reaction product is injected to the mercury-containing flue gas stream.

In another embodiment, the optional secondary component is selected from the group consisting of iodine, hydrohalides, Group V halides, Group VI halides, and combinations thereof. In another embodiment, the optional secondary component is added at from about 1 to about 15 wt % of the promoter content. In another embodiment, the method further comprises adding to the promoted sorbent a mercury-stabilizing reagent selected from the group consisting of S, Se, H<sub>2</sub>S, SO<sub>2</sub>, H<sub>2</sub>Se, SeO<sub>2</sub>, CS<sub>2</sub>, P<sub>2</sub>S<sub>5</sub>, and combinations thereof.

In an embodiment, the method further comprises co-injecting an optional alkaline material, including without limitation alkaline and alkaline-earth components, to improve the efficiency of mercury capture by capturing oxidized mercury and/or capturing gaseous components that might otherwise reduce promoted sorbent capacity. In another embodiment, the optional alkaline material may preferably comprise calcium oxide, sodium carbonate, and the like, as are known in the art.

In another embodiment, the method further comprises using the monitored mercury content of the cleaned flue gas to control the composition of the promoted sorbent. In another embodiment, the promoted sorbent is prepared in-flight by reacting a base sorbent (carbon, non-carbon, or their combination) and a promoter within the flue gas stream or in a transport line from which the reaction product is injected to the mercury-containing flue gas stream, wherein the promoter is selected from the group consisting of molecular halogens, halides, and combinations thereof, wherein the promoter is reacted in the gas phase or as a vapor, wherein the promoter is added at from about 1 to about 30 grams per 100 grams of the base sorbent (carbon, non-carbon, or their combination), wherein the rate at which the promoter is added and the rate of promoted sorbent injection are determined by a digital computer based, at least in part, on the monitored mercury content of the cleaned flue gas.

In an embodiment, a method for reducing the mercury content of a mercury and ash-containing gas stream is provided wherein particulate carbon and/or non-carbon promoted sorbent with a mass mean size greater than 40 μm is injected into the gas stream, mercury is removed from the gas by the promoted sorbent particles, the promoted sorbent particles are separated from the ash particles on the basis of size, and the promoted sorbent particles are reinjected to the gas stream. In another embodiment, the mercury-containing promoted sorbent particles are regenerated to remove some or substantially all of the mercury. In another embodiment, an alkaline component is co-injected into the gas stream. In another embodiment, the promoted sorbent may further comprise a promoter. The promoter may preferably comprise a halide, a halogen, or both.

In an embodiment, a method for reducing mercury in a mercury-containing gas to a desired level is disclosed. The method comprises reacting a carbon base sorbent with at least one promoter selected from the group consisting of molecular halogens, halides, and combinations thereof to

produce a promoted carbon sorbent; allowing said promoted carbon sorbent to interact with a mercury-containing gas to capture mercury in the mercury-containing gas on the promoted sorbent to produce a cleaned gas; and monitoring the mercury content of the cleaned gas. In some embodiments, the carbon base sorbent and the promoter are introduced into the mercury-containing gas at the same location or at separate locations. In some embodiments, the carbon base sorbent or promoter or combination thereof is introduced into the mercury-containing gas at one or more locations. In an embodiment, the rate at which the carbon base sorbent is introduced or the rate at which the promoter is introduced or combination thereof is adjusted according to the monitored mercury content of the cleaned gas so that the mercury content of the cleaned gas is maintained at substantially the desired level with minimal operating cost.

In a further embodiment, the method comprises reacting a non-carbon base sorbent with at least one promoter selected from the group consisting of molecular halogens, halides, and combinations thereof to produce a promoted non-carbon sorbent; allowing said promoted non-carbon sorbent to interact with a mercury-containing gas to capture mercury in the mercury-containing gas on the promoted sorbent to produce a cleaned gas; and monitoring the mercury content of the cleaned gas. In some embodiments, the non-carbon base sorbent and the promoter are introduced into the mercury-containing gas at the same location or at separate locations. In some embodiments, the non-carbon base sorbent or promoter or combination thereof is introduced into the mercury-containing gas at one or more locations. In an embodiment, the rate at which the non-carbon base sorbent is introduced or the rate at which the promoter is introduced or combination thereof is adjusted according to the monitored mercury content of the cleaned gas so that the mercury content of the cleaned gas is maintained at substantially the desired level with minimal operating cost.

In a further embodiment, a method for reducing mercury in a mercury-containing gas to a desired level is presented. The method comprises reacting a base sorbent with at least one promoter selected from the group consisting of molecular halogens, halides, and combinations thereof to produce a promoted sorbent, wherein said base sorbent is selected from the group consisting of a non-carbon material, a carbon material, and combination thereof; allowing said promoted sorbent to interact with a mercury-containing gas to capture mercury in the mercury-containing gas on the promoted sorbent to produce a cleaned gas; and monitoring the mercury content of the cleaned gas.

In some embodiments, the base sorbent and the promoter are introduced into the mercury-containing gas at the same location or at separate locations. In some embodiments, the base sorbent or promoter or combination thereof is introduced into the mercury-containing gas at one or more locations. In some embodiments, introducing the base sorbent and the promoter comprises injecting the base sorbent and the promoter into the mercury-containing gas. In some embodiments, the promoter is introduced into the mercury-containing gas upstream of the introduction of the base sorbent. In some embodiments, the promoter is introduced upstream of a boiler or a combustion chamber. In an embodiment, the rate at which the base sorbent is introduced or the rate at which the promoter is introduced or combination thereof is adjusted according to the monitored mercury content of the cleaned gas so that the mercury content of the cleaned gas is maintained at substantially the desired level with minimal operating cost.

In an embodiment, the base sorbent for the promoted sorbent is selected from the group consisting of carbon, activated carbon, porous felsic materials, vesicular felsic materials, porous basaltic materials, vesicular basaltic materials, clay-based compounds, alkaline compounds, calcium hydroxide compounds, sodium acetate compounds, bicarbonate compounds, and combinations thereof. In embodiments, the non-carbon material comprises Lewis basic groups and the carbon material comprises Lewis acid groups. In some cases, the non-carbon material comprises amorphous forms of tectosilicates comprising nanoscale cavities lined with Lewis basic oxygen associated with alkaline-earth metals. The alkaline-earth metals comprise Group I and Group II alkaline-earth metals. In some other cases, the non-carbon material comprises amorphous forms of phyllosilicates comprising nanoscale cavities lined with Lewis basic oxygen.

In an embodiment, the promoted sorbent comprises metastable complexes formed between the promoter of this disclosure and inorganic species on the non-carbon base sorbent. In some embodiments, the inorganic species is selected from the group consisting of sodium compounds, calcium compounds, magnesium compounds, aluminum compounds, iron compounds, and combinations thereof. In an embodiment, the promoted sorbent comprises metastable complexes formed between the promoter of this disclosure and metal-oxygen-metal structures on the non-carbon base sorbent. In some embodiments, the promoter after being complexed with the metal-oxygen-metal structures is in the form selected from the group consisting of a dihalogen group, a halogen atom, a hydrohalogen group, a Group V halide, a Group VI halide, and combinations thereof. In an embodiment, the promoted sorbent comprises activated Lewis basic groups or activated Lewis acid groups or combination thereof. In some embodiments, the interaction between promoted sorbent and said mercury-containing gas stream comprises mercury diffusing from the gas phase onto said promoted sorbent surface; and reacting with the activated Lewis basic groups or activated Lewis acid groups or combination thereof to cause chemisorption on the promoted sorbent surface.

In an embodiment, the method for reducing mercury in a mercury-containing gas to a desired level further comprises pretreating the base sorbent to increase the number of Lewis basic groups or Lewis acid groups or combination thereof. In some cases, the pretreating methods comprise chemical treatment, thermal treatment, vacuum treatment, and combinations thereof. In some embodiments, chemical treatment comprises acid treatment and alkaline treatment. In an embodiment, the method for reducing mercury in a mercury-containing gas to a desired level further comprises introducing an alkali component into the mercury-containing gas.

As will be described in more detail below, the present invention thus provides several advantages over previously known techniques, including significantly more effective and economical mercury sorbents for effluent gases, advantageously applicable to treating gas streams from combustion and gasification systems.

The foregoing has outlined rather broadly the features and technical advantages of the present invention in order that the detailed description of the invention that follows may be better understood. Additional features and advantages of the invention will be described hereinafter that form the subject of the claims of the invention. It should be appreciated by those skilled in the art that the conception and specific embodiments disclosed may be readily utilized as a basis for modifying or designing other structures for carrying out the

same purposes of the present invention. It should also be realized by those skilled in the art that such equivalent constructions do not depart from the spirit and scope of the invention as set forth in the appended claims.

#### BRIEF DESCRIPTION OF THE DRAWINGS

For a more detailed description of the preferred embodiments of the present invention, reference will now be made to the accompanying drawings.

FIG. 1 schematically illustrates methods for preparation of promoted carbon and/or non-carbon sorbents in accordance with the present invention.

FIG. 2 illustrates a proposed mechanistic model of the chemical reactions resulting in the oxidation and capture of mercury.

FIG. 3 schematically illustrates preparation of promoted carbon and/or non-carbon sorbents and processes for flue gas mercury reduction in flue gases and/or product gases from a gasification system in accordance with the present invention, including in-flight preparation of promoted carbon and/or non-carbon sorbent.

FIG. 4 illustrates a mechanism for promotion of metal oxide base sorbent via formation of a reactive halogen complex sorbent and subsequent capture of elemental mercury on the promoted sorbent.

FIG. 5A schematically illustrates an exemplary process flow diagram for in-flight preparation of a promoted carbon and/or non-carbon sorbent.

FIG. 5B schematically illustrates an exemplary process flow diagram for in-flight preparation of a promoted carbon and/or non-carbon sorbent.

FIG. 6 is a block diagram illustrating the use of the invention in a coal fueled facility.

#### DETAILED DESCRIPTION

Herein will be described in detail specific preferred embodiments of the present invention, with the understanding that the present disclosure is to be considered an exemplification of the principles of the invention and is not intended to limit the invention to that illustrated and described herein. The present invention is susceptible to preferred embodiments of different forms or order and should not be interpreted to be limited to the specifically expressed methods or compositions contained herein. In particular, various preferred embodiments of the present invention provide a number of different configurations and applications of the inventive method, compositions, and their uses.

The present invention provides a cost-effective way to capture pollutants by utilizing exceptionally reactive halogen/halide-promoted sorbents using a bromide (or other halogen/halide) treatment of the promoted sorbent, that capture mercury via mercury-sorbent surface reactions, at very short contact times of seconds or less. The reactivity of the promoted sorbent toward the pollutants (i.e., mercury) is greatly enhanced, and the sorption capacity can be regenerated; i.e., the promoted sorbent may be regenerated, recycled and/or reused.

The treated base sorbents (carbon, non-carbon, or their combination), treatment techniques, and optional additives discussed herein have applicability to mercury control from the product or effluent gas or gases from gasification systems, syngas generators, and other mercury-containing gas streams, in addition to the flue gas from combustion systems. Thus it should be understood that the terms combus-

tion system and flue gas as used throughout this description may apply equally to gasification systems and syngas or fuel gas, as will be understood by those skilled in the art.

Hereinafter the disclosure may at times discuss the use of carbon base sorbents in further details; however the use of non-carbon base sorbents and a combination of carbon and non-carbon base sorbents is also contemplated to at least the same degree as carbon base sorbents.

Referring now to FIG. 1, there is shown a block flow diagram illustrating some preferred embodiments of the process of the present invention to prepare promoted sorbents useful for mercury capture in a mercury containing gas, such as a flue gas and/or product gas from gasification system streams. In a preferred embodiment illustrated by path 10-20, block 10 illustrates providing a base sorbent while block 20 illustrates adding a halogen or halide promoter that reacts with the base sorbent to produce a product-promoted sorbent. In embodiments where the halogen or halide is added, for example, as a vapor, no further steps may be necessary. In embodiments where the halogen or halide is added in, for example, a solvent, it may be desirable to employ solvent removal as illustrated by block 20A to produce a product-promoted sorbent suitable for injection.

Referring still to FIG. 1, another preferred embodiment of the process of the present invention is illustrated by path 10-20-30, comprising providing a base sorbent as shown by block 10, adding a halogen or halide promoter that reacts with the base sorbent, illustrated at block 20, and adding a secondary component illustrated at block 30 that reacts with the result of block 20 to produce a product-promoted sorbent. In embodiments where both the halogen or halide promoter and the secondary component are added, for example, as a vapor, no further steps may be necessary. In embodiments where the halogen or halide promoter and/or secondary component are added in, for example, a solvent, it may be desirable to employ solvent removal as illustrated by block 30A to produce a product-promoted sorbent suitable for injection.

Referring still to FIG. 1, another preferred embodiment of the process of the present invention is illustrated by path 10-40, comprising providing a base sorbent as illustrated at block 10 and adding a halogen or halide promoter and a secondary component to the base sorbent together, with which they react to produce a product-promoted sorbent as illustrated by block 40. As above, in embodiments where vapor additions are made to the base sorbent, no further steps may be desired. In embodiments where one or more components are added in solvent, a solvent removal step may be provided as illustrated by block 40A to produce a product-promoted sorbent suitable for injection.

Referring still to FIG. 1, another preferred embodiment of the process of the present invention is illustrated by path 10-50 in combination with path 20-50. In this embodiment, a base sorbent as illustrated by block 10 is introduced to the mercury containing gas as illustrated by block 50 while a halogen or halide promoter as illustrated by block 20 is introduced to the mercury containing gas stream. Thus the base sorbent and promoter react at block 50 to produce a product-promoted sorbent. In a similar manner, a secondary component as illustrated by block 30 may be added to the halogen or halide promoter as illustrated by block 20 and introduced into the mercury containing gas as illustrated by block 50. In embodiments where both the halogen or halide promoter and secondary component are added, for example, by vapor, no further steps may be taken. In embodiments where the halogen or halide and/or secondary component are

## 11

added in, for example, a solvent, it may be desirable to employ solvent removal as illustrated by block 20A and/or block 30A.

Referring still to FIG. 1, also illustrated are preferred embodiments in which, as illustrated by block 50, a mercury containing gas stream is treated with product-promoted carbon sorbent prepared as described above.

In some preferred embodiments, the carbon base sorbent provided may preferably be any of several types, as understood by those skilled in the art. For example, the carbon base sorbent may include powdered activated carbon, granular activated carbon, carbon black, unburned carbon, carbon fiber, carbon honeycomb or plate structure, aerogel carbon film, pyrolysis char, regenerated activated carbon from product-promoted carbon sorbent, or other types as known in the art.

In some preferred embodiments, the carbon base sorbent provided may preferably have a mass mean particle size greater than the fly ash in a mercury containing gas, such as a flue gas stream, to be treated.

In some preferred embodiments, the carbon base sorbent provided may preferably have a mass mean particle diameter preferably greater than 40 micrometers, more preferably greater than 60 micrometers, or a particle-size distribution greater than that of the fly ash or entrained ash in a flue gas stream, or other mercury containing gas, to be treated, such that the activated carbon and ash can be separated by physical means.

In some preferred embodiments, the halogen or halide promoter that is added to, and reacts with, the carbon base sorbent may preferably comprise, by way of illustration and not limitation, a molecular halogen in vapor or gaseous form, a molecular halogen in an organic solvent, a Group V or Group VI halide, such as  $\text{PBr}_3$  or  $\text{SCl}_2$ , respectively, in vapor, liquid, or solution form (though not in an aqueous solvent).

Embodiments are also provided in which the organic solvent may preferably comprise a chlorinated hydrocarbon, such as dichloromethane, a hydrocarbon solvent, including for example, petroleum ether, ligroin, pentane, hexane, toluene, and benzene, carbon disulfide, a waste solvent, an ether, a recycled solvent, a supercritical solvent, such as supercritical  $\text{CO}_2$ , water (though not in the case of a Group V or Group VI halide), and others as will be apparent to those of skill in the art.

Referring now to FIG. 4, a theory is illustrated developed from scientific evidence to explain the nature of the promoting compounds. For example, as illustrated in FIG. 4, a molecular bromine molecule forms a complex with the surface of the base sorbent comprising a high surface area form of a metal oxide. Complexing with bromine can occur at surface and defect sites on the surface of the glassy amorphous tectosilicates by association with the Lewis basic oxygen lining the interstitial cavities and the alkali actions on the surface. Molecular hydrogen bromide or an electrophilic or Lewis acid bromine compound react to form a similar structure. The precedence for this promotion of a metal oxide surface complex with an acidic species is described in a paper by Stark and Klabunde (Klabunde, K. J. Chem. Mater. 1996, 8, 1913-1918) who showed addition of acids,  $\text{HCl}$ ,  $\text{SO}_3$ , and  $\text{NO}$ , to a  $\text{MgO}$  surface to form a surface complex. In U.S. Pat. No. 6,517,423 to Koper et al. the described surface complexes were active for destroying biological agents and toxins. As shown in FIG. 4, addition of halogens to a metal oxide surface (A) can form a complex that could be described as a bromide-oxybromide species (B), in which electrophilic reactivity is maintained, owing to

## 12

the formation of positive charges on the surface. The electrophilic complex formed on the metal oxide base sorbent comprises an active site for oxidation of elemental mercury. Addition of mercury to the complex results in formation of a mercury oxygen bond and, simultaneously, a mercury bromine bond as shown in complex C in FIG. 4. Thus the final structure is a stable oxidized Hg form (D) described as a metaloxymercuric bromide.

In summary, it has now been found that the formation of the new bromide complex with the metal oxide surface increases the surface reactivity toward mercury and other pollutants. Additionally, the resulting bromide compound is uniquely suited to facilitate oxidation of the mercury. The effectiveness of the oxidation apparently results from the promotion effect of the halide, exerted on the developing positive charge on the mercury during the oxidation, known in the chemical art as a specific catalytic effect. Thus as the mercury electrons are drawn toward the positive surface oxygen, the halide anion electrons are pushing in from the other side, stabilizing the positive charge developing on the mercury and lowering the energy requirement for the oxidation process. Bromide is especially reactive, owing to the highly polarizable electrons in the outer 4p orbitals of the ion. Thus adding  $\text{HBr}$  or  $\text{Br}_2$  to the appropriate metal oxide forms a similar surface bromide complex, in which the positive oxygen oxidizes the mercury with the assistance of the bromide ion.

In embodiments, a non-carbon base sorbent with Lewis basic sites/groups comprising metal-oxygen-metal structures is activated by a promoter of this disclosure, forming a promoted sorbent. The promoter and the metal-oxygen-metal structures of the non-carbon base sorbent form metastable complexes, which are responsible for mercury capture via chemisorption. For example, metastable complexes may form between a halogen promoter and inorganic species on a non-carbon base sorbent, wherein inorganic species include sodium (Na), calcium (Ca), magnesium (Mg), aluminum (Al), iron (Fe) compounds, and combinations thereof. In some embodiments, the metastable complexes comprise a dihalogen group, such as  $\text{Br}-\text{Cl}$ ,  $\text{Br}-\text{Br}$ , complexed with metal-oxygen-metal structures of the base sorbent. In some embodiments, the metastable complexes comprise a halogen atom, complexed with metal-oxygen-metal structures of the base sorbent. In some embodiments, the metastable complexes comprise a hydrohalogen group, complexed with metal-oxygen-metal structures of the base sorbent. In some embodiments, the metastable complexes comprise a Group V or Group VI halide, complexed with metal-oxygen-metal structures of the base sorbent. In some embodiments, the metal-oxygen-metal structures of the base sorbent are complexed with combinations of the functional groups disclosed herein. Without wishing to be limited by a theory, it is believed that mercury capture via chemisorption takes place through the action of mercury oxidation provided by these metastable complexes.

In embodiments, a carbon base sorbent with Lewis acid sites/groups comprising graphene sheets is activated by a promoter of this disclosure, forming a promoted sorbent. The promoter and the graphene sheets of the carbon base sorbent form stable compounds, which are responsible for mercury capture via chemisorption. Without being limited by a theory, it is believed that mercury capture via chemisorption takes place through the action of mercury oxidation provided by these stable compounds. As one skilled in the art would appreciate, the versatility of chemistry associated with the base sorbent (carbon, non-carbon, or combination thereof) and the promoter of this disclosure

enables versatile applications of the promoted sorbent system for mercury capture. This is especially advantageous because mercury content in flue gases varies from facility to facility, from operation to operation, and from day to day.

Examples of non-carbon base sorbents are amorphous forms of tectosilicates that comprise nanoscale cavities lined with Lewis basic oxygen associated with Group I alkali metals and Group II alkaline-earth metals. Such tectosilicates can be found in naturally occurring minerals, including, but not limited to, perlite and pumacite. Examples of non-carbon base sorbents also include amorphous forms of phyllosilicates. It is appreciated that other minerals may be used and also treated chemically and thermally to increase the activity of the base sorbent materials, such as phyllosilicates in the amorphous forms.

In some embodiments, bentonites are used as non-carbon base sorbents, including sodium bentonite and calcium bentonite. The use of other types of bentonites is contemplated as is known to one skilled in the art. The application of bentonite base sorbents is by introducing them into the flue gas at a location of the mercury capture system wherein the temperature of that location is below 800° C.

In some embodiments, the base sorbents are treated chemically and/or thermally to increase their activity. For example, perlite as a base sorbent may go through vacuum treatment and then thermal treatment so as to reduce the moisture contained therein, increase its activity, and potentially alter its morphology. Other treatment processes include chemical treatment, such acid treatment and alkaline treatment. These treatment methods may be combined to achieve desired effects as known to one skilled in the art. One of the desired effects is to increase the number of available Lewis acid sites/groups in the carbon base sorbent and/or the number of available Lewis basic sites/groups in the non-carbon base sorbent for subsequent activation via reaction with a promoter disclosed herein.

Referring now to FIG. 3, a schematic flow diagram is provided of mercury control system 100 comprising preparation of promoted base sorbents and flue gas mercury reduction in accordance with preferred embodiments of the present invention. In the exemplary embodiment shown, there is provided a base sorbent reservoir 110, a halogen/halide promoter reservoir 120, a secondary component reservoir 130, and an alkali component reservoir 180, each of which with corresponding flow control device(s) 201, 202, 203, and 208/209, respectively. In conjunction with the alkali component reservoir 180, flow control devices 208 and 209 can be used independently, together, or not at all. Further, reservoirs 110, 120, 130 and 180 are optional and can be used in any combination, or not at all, whereby the otherwise stored components can be introduced into the system by other means either together or independently. Further, the alkali and secondary components may not be used at all within the system, if so desired.

As shown, reservoirs 110, 120, 130, and 180 connect through their respective flow control devices and via associated piping, to transport line 115. Alkali component reservoir 180 may also connect, through respective flow control devices and via associated piping, to transport line 118. A source of air, nitrogen, or other transport gas(es) is provided by gas source 170 to transport line 115 for the purpose of entraining materials discharged from reservoirs 110, 120, 130, and 180 and injecting such materials, via injection point 116, into contaminated flue gas stream 15. A source of air, nitrogen, or other transport gas(es) may be provided by gas source 171 to transport line 118 for the purpose of entraining materials discharged from reservoirs 180 and injecting such

materials, via injection point 119, into flue gas stream 15. Gas sources 170 and 171 may be the same or different, as desired. Alternatively, transport gas(es) may be provided to both transport lines 115 and 118 by gas source 170 (connection from source 170 to line 118 not shown). Although gas sources 170 and 171 are shown in FIG. 3 as compressors or blowers, any source of transport energy known in the art may be acceptable, as will be appreciated by those of skill in the art.

For clarity, single injection points 116 or 119 are shown in FIG. 3, although one skilled in the art will understand that multiple injection points and/or locations are within the scope of the present invention. In the embodiment shown, transport line 15 comprises multiple lines allowing for multiple injections and separate and/or combined injections of base sorbent 110 and promoter 120 and/or 130. One mode of operation, by example, comprises providing base sorbent 110 in a common line which is promoted inline “in-flight” using promoter 120 and/or 130 and injected at point 116. Another mode of operation, by example, comprises transport and injection of a base sorbent 110 in a separate line to a point downstream of the injection of promoter 120 and/or 130 in a line at point 116 which is upstream of injection of base sorbent 110, resulting in in-flight preparation at a promoted sorbent within stream 15.

In the exemplary embodiment shown, an optional optical density measuring device(s) 204 is connected to transport line 115 and/or 118 to provide signals representative of the optical density inside transport line 115 and/or 118 as a function of time.

Downstream from injection point 116 and 119 is provided particulate separator 140. By way of illustration and not limitation, particulate separator 140 may comprise one or more fabric filters, one or more ESPs, or other particulate removal devices as are known in the art. It should be further noted that more than one particulate separator 140 may exist, sequentially or in parallel, and that injection point 116 and 119 may be at multiple locations upstream and/or downstream of 140 when parallel, sequential, or combinations thereof exist. Particulate separator 140 produces at least a predominantly gaseous (“clean”) stream 142 and a stream 141 comprising separated solid materials. A sorbent/ash separator 150 separates stream 141 into a largely ash stream 152 and a largely sorbent stream 151. Stream 151 may then preferably be passed to an optional sorbent regenerator 160, which yields a regenerated sorbent stream 161 and a waste stream 162.

An optional continuous emission monitor (hereinafter “CEM”) 205 for mercury is provided in exhaust gas stream 35 to provide electrical signals representative of the mercury concentration in exhaust stream 35 as a function of time. The optional mercury CEM 205 and flow controllers 201, 202, 203, 208, and 209 are electrically connected via optional lines 207 (or wirelessly) to an optional digital computer (or controller) 206, which receives and processes signals and preferably controls the preparation and injection of promoted carbon sorbent into contaminated flue gas stream 15.

In operation, as example, promoted sorbent and/or an optional alkali component is injected into contaminated flue gas stream 15. After contacting the injected material with the contaminated flue gas stream 15, the injected material reduces the mercury concentration, transforming contaminated flue gas into reduced mercury flue gas, 25. The injected material is removed from the flue gas 25 by separator 140, disposed of or further separated by optional separator 150, and disposed of or regenerated by an optional regenerator 160, respectively. The reduced mercury clean

flue gas stream **142** is then monitored for mercury content by an optional CEM **205**, which provides corresponding signals to an optional computer/controller **206**. Logic and optimization signals from **206** then adjust flow controllers **201**, **202**, **203**, **208**, and **209** to maintain the mercury concentration in exhaust stream **35** within desired limits, according to control algorithms well known in the art. Flow controllers **201**, **202**, **203**, **208**, and **209** can also be adjusted manually or by some other automated means to maintain the mercury concentration in exhaust stream **35** within desired limits, according to control algorithms well known in the art.

Referring still to FIG. **3**, several embodiments are illustrated for preparation and injection of promoted sorbents and/or alkali components in accordance with the present invention. Stream **111** provides for introduction of base sorbent from reservoir **110**, as metered by flow controller **201** manually or under the direction of computer **206**. The halogen/halide may be combined and react with the base sorbent according to any of several provided methods. The halogen/halide may preferably be combined via line **121** directly into transport line **115**, within which it contacts and reacts with the base sorbent prior to injection point **116** or downstream at point **116**. This results in in-flight preparation of a promoted sorbent in accordance with the invention. Further, the halogen/halide may be combined via line **121b** with the base sorbent prior to entering transport line **115**. Still further, the halogen/halide may be contacted and react with the base sorbent by introduction via line **121c** into reservoir **110**. This option is preferably employed when, for example, reservoir **110** comprises an ebulliated or flueidized bed of base sorbent, through which halogen/halide flows in gaseous form or as a vapor. Of course, the halogen/halide may also preferably be contacted with the base sorbent in liquid form or in a solvent, as discussed previously, and solvent removal (not shown in FIG. **3**) may then be provided if necessary as mentioned with respect to embodiments discussed with reference to FIG. **1**.

Similarly, the optional secondary component may be contacted and react directly in transport line **115** via line **131**, or optionally as described above with respect to the halogen/halide, via lines **131b** and **131c**.

Similarly, the optional alkali component from **180** may either be added in transport line **115** directly, or may be injected separately by transport line **118**, combining downstream in flue gas **15** for synergistic effects with the base sorbent, promoted sorbent, or optional secondary components. Being able to vary on-site the amount of the optional alkali component relative to base sorbent, promoted sorbent, or optional secondary components is a key feature to overcome and optimize for site-specific operating and flue gas conditions.

In some preferred embodiments wherein contacting between components and reaction is performed in a liquid or solvent phase, stirring of such liquid and/or slurry mixtures may be provided. In other embodiments, the halogen/halide promoter and optional secondary component(s) may preferably be sprayed in solution form into or on the base sorbent. In some such embodiments, drying, filtering, centrifugation, settling, decantation, or other solvent removal methods as are known in the art may then be provided.

In embodiments wherein the halogen/halide promoter is in gaseous or vapor form, it may be diluted in air, nitrogen, or other gas as appropriate. The halide/halogen gas, for example, gaseous HBr or Br<sub>2</sub>, may be passed through an ebulliated or flueidized bed of granular or fibrous base sorbent, with the promoted sorbent so produced removed from the top of the bed via gas entrainment for injection.

In some embodiments, the secondary component(s) may preferably comprise iodine or other halogens, hydrohalides, including without limitation HI, HBr, HCl, a Group V or Group VI element with a molecular halogen, such as SCl<sub>2</sub> and others. In some preferred embodiments, the promoted sorbent may comprise from about 1 to about 30 g of halogen/halide per 100 g of base sorbent. In some preferred embodiments, the promoted sorbent may comprise a secondary component in concentration of from about 1 to about 15 wt % of the concentration of the halogen/halide component.

In still other embodiments, the product-promoted sorbent may be applied to a substrate. In other embodiments, such prepared substrate(s) may be caused to contact a contaminated flue gas or gasification system product gas stream for mercury reduction purposes. Such substrates may be monolithic, rotating, or exposed to the gas stream in any number of ways known to those skilled in the art.

In some embodiments, a method is provided whereby a mercury stabilizing reagent is added to a promoted sorbent to produce a bifunctional sorbent. Such stabilizing reagent(s) may be sequentially added, either before or after the addition and reaction of the halogen/halide. In some preferred embodiments, the halogen/halide preferably comprises Br or HBr, and the mercury-stabilizing reagent may comprise S, Se, H<sub>2</sub>S, SO<sub>2</sub>, H<sub>2</sub>Se, SeO<sub>2</sub>, CS<sub>2</sub>, P<sub>2</sub>S<sub>5</sub>, and combinations thereof.

#### Halogens in Mercury Capture

Methodologies for using halogens for the treatment of flue gas have been problematic, owing to their reactivity with other gases and metals, resulting in corrosion and health issues. A "halogen" is defined as a member of the very active elements comprising Group VIIA (CAS nomenclature is used throughout; Group VITA (CAS) corresponds to Group VIIB (IUPAC)) of the periodic table. In the molecular elemental form of the halogens, including F<sub>2</sub>, Cl<sub>2</sub>, Br<sub>2</sub>, and I<sub>2</sub>, the reaction with hot flue gas components leaves little to react with elemental mercury. The atomic elemental halogen form, which includes the fluorine, chlorine, bromine, and iodine atoms, is about a million times more reactive to mercury, but the concentration of the atomic forms is typically extremely low. In a large portion of electric utility coal combustion facilities, the concentrations are generally not sufficient to oxidize a significant amount of mercury.

The term "halide" as used herein is defined as a compound formed from the reaction of a halogen with another element or radical. In general, halide compounds are much less reactive than the molecular halogens, having a low chemical potential. Halides are considered reduced forms that do not, alone, oxidize other compounds. In the conventional view, therefore, a halide salt-treated sorbent will not effectively oxidize elemental mercury and capture elemental mercury.

#### Halogen-Promoted Sorbent Characteristics

The promoted sorbent described here has a very high initial reactivity for oxidizing mercury and therefore, can be used in very small amounts to achieve very high capture efficiencies, thus lowering operation costs and lessening waste disposal problems. In addition, further disposal reductions are obtainable by regenerating and reusing the promoted sorbents produced using the inventive technology. The time interval required for the mercury and the promoted sorbents of the present invention to successfully interact in a flue gas duct, with subsequent collection of the mercury on the promoted sorbent and ash, is very short—less than seconds. Clearly, such collection times require the promoted sorbent to have both high capacity and high reactivity toward mercury. The promoted sorbent can be utilized in a

very finely powdered form to minimize mass-transfer limitations. However, again, the reactivity should be very high to capture all of the mercury encountered by the fine particles. Additionally, use of these enhancement technologies allows capture to be effective for larger sorbent particles which also allows separation of the promoted sorbent from the ash to enable subsequent regeneration as well as ash utilization. One feature of this invention is the process to prepare a promoted sorbent containing a halide component formed on and/or within the base sorbent structure that provides a sorbent that is highly active on initial contact with the mercury-contaminated gas stream, which allows for very effective capture of the mercury.

The inventive sorbents chemically combine bromine species with Lewis acid/basic sites on the base sorbent. For example, x-ray photoelectron spectroscopy has established that the addition of bromine, chlorine, HBr, or HCl formed a chemical compound in the carbon structure. Thus the promoted sorbent produced from halogen and base sorbent does not represent a molecular halogen form, but rather a new chemically modified structure. This phenomenon may not occur with the less reactive iodine, where an I<sub>2</sub> molecular complex can exist on the carbon basal plane. In the case of bromine, modified cationic carbon has a high chemical potential for oxidation of mercury. Thus an entirely new model is presented for the reactivity of the bromine-treated carbon with mercury shown in FIG. 2. The reactive carbon form can preferably be generated by the addition of bromine, hydrogen bromide, or combinations of bromine and other elements, as described herein. Halogen treatment resulted in higher-activity carbons because the halide anions (especially bromide and iodide) were effective in promoting oxidation by stabilizing the developing positive charge on the mercury in the transition state for oxidation. Based on this model, several innovative, inexpensive, activity-enhancing features have been developed.

#### Optional Second Component

It has been demonstrated that addition of an optional second component, in addition to the bromine, results in improved reactivity and capacity for the promoted sorbent, typically exceeding that of both the untreated base sorbent and the brominated carbon. The second compound comprises either a second halogen or a compound derived from a second halogen, such as HI. Thus in addition to having a reactive carbon form present, the second component generates a Lewis base with greater ability to stabilize the developing positive charge on the mercury. Thus the second component is an element with more polarized electrons (4p and 5p).

#### Optional Alkali Component

It has been demonstrated that addition of an optional alkali component with a base or promoted activated carbon results in improved mercury capture, typically exceeding that of both the untreated carbon and the promoted carbon. Test data indicate that flue gas contaminants, flue gas constituents (SO<sub>2</sub>, NON, HCl, etc), operating temperature, mercury form, and mercury concentration may impact the effectiveness of the alkali addition. This suggests the need to be able to adjust and tailor the alkali-to-activated-carbon ratio on-site in order to overcome and optimize for a given set of site conditions.

The synergy that can be gained when coinjecting the two materials can be explained as follows. First, testing shows that binding sites on activated carbon (hereinafter "AC") can be consumed by chlorine species, sulfur species (i.e., sulfates), and other flue gas contaminants (arsenates, selenates, etc). The addition of optional alkali material will interact and

react with these species/contaminants, thus minimizing their consumption of AC mercury binding sites. Second, testing also shows that standard AC will continue to oxidize mercury, even though the binding sites are fully consumed. This oxidized mercury can then react with alkali material and subsequently be captured by particulate control devices. Consequently, the addition of the optional alkali component acts to protect mercury-binding sites and capture oxidized mercury, thereby resulting in improved mercury reduction at lower cost. Alkali is generally much lower in cost (an order of magnitude less) than AC; thus more of it can be used, still resulting in overall lower costs.

#### In-Flight Sorbent Preparation

As stated previously, the halogen promoted sorbent can be readily produced in-flight. This is accomplished by, for example, contacting the vapors of any combination of halogens and, optionally, a second component, in-flight, with base sorbent particles. The particles may be dispersed in a stream of transport air (or other gas, such as the flue gas itself), which also conveys the halogen/halide-promoted sorbent particles to the flue gas duct, or other contaminated gas stream, from which mercury is to then be removed. There is no particular temperature requirement for this contact. This technology is obviously very simple to implement, and results in a great cost savings to facilities using this technology for mercury capture.

Referring to FIGS. 5A and 5B, process flow diagrams are shown as examples of the process for mercury removal from a mercury containing gas, such as a flue gas. In an embodiment shown at FIG. 5A, gas inlet stream 501 passes through chamber 301 and enters air heater 302 as stream 502; then it exits air heater 302 as stream 503 and passes through particulate control device 303 and enters scrubber 304 as stream 504; finally it exits scrubber 304 as stream 505. As shown, chamber 301 is a boiler, however, one skilled in the art will appreciate that chamber 301 can also be the combustion chamber of a coal fired boiler, a stand alone combustion chamber or any other chamber in which mercury containing gas is either generated or passed through. Injection streams 401, 402, 403 and 404, in addition to stream 501, are multiple locations wherein promoter, base sorbent, or a combination of promoter and base sorbent may be introduced.

FIG. 5B shows an embodiment similar to that of FIG. A, but with the position of the scrubber and particulate control device switched. Specifically, gas inlet stream 501' passes through chamber 301' and enters air heater 302' as stream 502'; then it exits air heater 302' as stream 503' and passes through scrubber 304' and enters particulate control device 303' as stream 504'; finally it exits particulate control device 303' as stream 505'. As shown, chamber 301 is a boiler, however, one skilled in the art will appreciate that chamber 301 can also be the combustion chamber of a coal fired boiler, a stand alone combustion chamber or any other chamber in which mercury containing gas is either generated or passed through. Injection stream locations 401', 402', 403' and 404', in addition to stream 501', represent multiple locations wherein promoter, base sorbent, or a combination of promoter and base sorbent may be introduced.

At each of the aforementioned injection stream locations 401, 401', 402, 402', 403, 403', 404 and 404', 501, 501' multiple injection points are contemplated so that promoter and base sorbent may be injected as a single injection stream or as separate injection streams, as further illustrated in the following exemplary embodiments.

In an embodiment, a promoter is introduced to chamber 301 at location 401. A base sorbent (carbon, non-carbon, or

their combination) is introduced at location 402 upstream of air heater 302. In a further embodiment, a promoter is introduced to at location 402 upstream of air heater 302. A base sorbent (carbon, non-carbon, or their combination) is also introduced at location 402 either as a separate stream or as a mixed single stream with the promoter. In another embodiment, a promoter is introduced at locations 401 and 402. A base sorbent (carbon, non-carbon, or their combination) is introduced at location 402 either as a separate stream or as a mixed single stream with the promoter.

With the aid of this disclosure, one of ordinary skill in the art will be able to configure the process in many different fashions for mercury removal using the promoted sorbent. All these configurations are considered equivalents of the disclosed process and therefore are within the scope of the claimed invention.

#### Advantages of On-Site Preparation

In-flight preparation of the halogen/halide-promoted sorbent on location produces certain advantages. For example, the treatment system can be combined with the base sorbent injection system at the end-use site. With this technique, the halogen/halide is introduced to the base sorbent air (or other gas, including to the flue gas or other mercury containing gas) mixture in a transport line (or flue gas duct part of the base sorbent storage and injection system). This provides the following benefits over current conventional concepts for treating sorbents off-site:

Capital equipment costs at a treatment facility are eliminated.

Costs to operate the treatment facility are eliminated.

There are no costs for transporting carbon and additive to a treatment facility.

The inventive process uses existing hardware and operation procedures.

The inventive technology ensures that the sorbent is always fresh and, thus, more reactive.

No new handling concerns are introduced.

There are no costs for removing carbon from treatment system.

The inventive process allows rapid on-site tailoring of additive-sorbent ratios in order to match the requirements of flue gas changes, such as may be needed when fuels are changed or loads are reduced, thus further optimizing the economics.

The inventive technology reduces the amount of spent sorbents that are disposed.

With the foregoing and other features in view, there is provided, in accordance with the present invention, embodiments including a process for preparing and regenerating halogen/halide-promoted sorbents, whose activity for mercury capture is enhanced by the addition of halogen (e.g., bromine) to the base sorbent structure.

#### Sorbent Injection Location

Some of the preferred embodiments contemplate the use of a halogen-promoted sorbent in a powdered form that has been injected into a flue gas stream before or after ash particulates have been removed. Other embodiments of the inventive composition of the halogen-promoted sorbent comprise a powdered modified AC prepared by adding Br<sub>2</sub> or HBr plus a second optional component. Other embodiments allow the addition of the optional alkali component in conjunction with a base AC and/or with the use of a halogen-based sorbent and any other combinations of the sorbent technologies provided in this patent. Other embodiments allow for in-flight preparation of promoted sorbents by using and combining the promoters and base sorbents. Alternatively, embodiments include methods wherein the

base sorbent is on a moving contactor consisting of particles or fibers containing one or more of the compositions listed above.

#### Sorbent Regeneration

Any of the above embodiments of the halogen/halide-promoted carbon and/or non-carbon sorbent can be easily regenerated; the poisoning contaminants from the flue gas are preferably removed, and an inexpensive promoting agent added, to restore mercury sorption activity. This process of promoting the activity of the carbon and/or non-carbon itself contrasts with the earlier, more expensive, conventional methods of adding a reagent (such as peroxide, gold, triiodide, etc.) to a base sorbent. The halogen/halide-promoted carbon sorbent of the present invention, treated with bromine and/or optional components, is noncorrosive. Detailed examples of sorbent regeneration techniques are described in copending, commonly owned PCT Patent Application No. PCT/US04/12828, titled "PROCESS FOR REGENERATING A SPENT SORBENT," which is hereby incorporated by reference in its entirety.

#### Sorbent Injection Control Schemes

Another advantage of the present invention relates to the use of a feedback system to more efficiently utilize certain aspects of the invention. Where possible and desirable, the mercury control technology of the present invention may preferably utilize continuous measurement of mercury emissions as feedback to assist in control of the sorbent injection rate. Tighter control on the sorbent and optional component(s) levels can be achieved in this way, which will ensure mercury removal requirements are met with minimal material requirements, thus minimizing the associated costs. In an embodiment, the mercury emissions are continuously measured downstream of the injection location, preferably in the exhaust gas at the stack.

## EXAMPLES

To more clearly illustrate the present invention, an example is presented below. This example is intended to be illustrative, and no limitations to the present invention should be drawn or inferred from the example presented herein.

### Example 1

#### Non-carbon-Promoted Sorbent Tests at Full-Scale Plants

Full-scale commercial tests were conducted at several coal-burning facilities equipped with ESPs wherein three types of pre-cursors were injected upstream of an ESP at 325° F. In all, more than thirty tests were performed with variations in base sorbent material, base sorbent material injection rates and promoter injection rates. Promoters were halogen-based materials. Base sorbents were clay-based materials such as perlite and pumacite, which are vesicular forms of tectosilicates comprising silicates and aluminate tetrahedra with alkali metals in the interstitial spaces. Each base sorbent was injected upstream from the ESP.

The flue gas flow rate for the test was approximately 23 million dsft<sup>3</sup>/hr with a corresponding mercury flow rate of 0.0097 lbs Hg/hr. Initial mercury concentration in the flue gas prior to the introduction of the base sorbent or promoted sorbent was approximately 0.000417 lbs Hg/million dsft<sup>3</sup>.

As shown in Table 1, each base sorbent was injected at three different test rates: about 100 lb/hr ("Low"), about 150 lb/hr ("Ave.") and about 200 lb/hr ("High"). At each test

rate, the mercury removal rate was measured both with and without the use of a promoter to show the relative benefit of introducing the promoter into the flue gas stream. For the tests where promoter was injected into the flue gas stream, promoter was injected at about 20 lb/hr for the "Low" tests, at about 25 lb/hr for the "Ave." tests and from about 30 to about 50 lb/hr for the "High" tests. The percent mercury removal for each test was calculated based on measurements taken from the inlet flue gas and the outlet flue gas. The results as shown in Table 1 clearly show a significant improvement in mercury capture when a promoter and base sorbent are injected, as compared to the injection of a base sorbent alone.

TABLE 1

Test Data for Non Carbon-Promoted Sorbents									
Base Sorbent	Base Sorbent Injection Rate (lb/hr)			Promoter Injection Rate (lb/hr)			Percent Removal of Mercury (%)		
	Low	Ave.	High	Low	Ave.	High	Low	Ave.	High
Perlite	100	150	200	0	0	0	37	40	43
	100	150	200	20	25	35	55	72	74
Pumacite	100	150	200	0	0	0	25	25	25
	100	150	200	20	25	50	52	60	65
Clay-Based Mix of Silica and Alumina	100	150	200	0	0	0	50	52	54
	100	150	200	20	25	30	58	65	74

## PROVISIONAL APPLICATION

A reactive sorbent material is described for capture of mercury in a vapor stream. The vapor stream includes flue gas from coal combustion or incineration, synthesis gas from gasification, as well as offgases from mineral processing, metal refining, retorting, cement manufacturing, chloralkali plants, dental facilities, and crematories. The sorbent is especially suited to, but not limited to, use in low-chlorine flue or exhaust gases where the mercury is mainly elemental. The sorbent comprises a bromide-modified carbon form containing a reactive compound produced by the reaction of bromine with the carbon. Other additional promoting substances can be added in smaller amounts to increase the reactivity with and sorption of elemental mercury. This combination results in a carbon bromide structure in the carbon lattice that can oxidize the mercury to a species that is strongly bonded to the carbon structure and, therefore, easily retained on the sorbent at higher temperatures in the presence of flue gas constituents. In some examples, the sorbent consists of a fine or coarse powdered material for injection into the gas stream or a granular or fibrous material for use in a fixed or moving bed. In some examples, the sorbent does not require in situ activation (an induction period) in a flue gas stream as do conventional activated carbon sorbents. Other additives of base chemistry (Ca, Na, and others) may be added to flue gas as a sorbent mixture, or co-injected to selectively sorb acid gases or other flue gas constituents to keep available reactive sites for mercury oxidation and subsequent capture. The sorbent can be regenerated by washing off contaminating components derived from flue gas that poison the spent sorbent. Novel methods for introduction of the sorbent dispersion into the mercury contaminated gas stream are described.

Following is an outline of examples of the invention. The invention may also take on various other examples or embodiments, as a person skilled in the art would understand.

1. A modified carbon sorbent was prepared by reacting the carbon with molecular bromine by applying a solution of molecular bromine in an organic solvent to the carbon, followed by removal of the modified carbon from the bulk of solvent and further removal of solvent from the pores by drying the carbon in air or nitrogen. The solution may also contain an additional promoting substance in small amounts. In one example, the amount of bromine taken up by the carbon ranges from <1 to about 30 g per 100 g of activated carbon, depending on the proportions used.

1A. (Dependent)

Same as 1, carbon is powdered activated carbon.

Carbon is granular activated carbon.

Carbon is very fine carbon black.

Carbon is very fine carbon fiber.

Carbon is aerogel carbon film.

Carbon is char recovered from pyrolysis process.

Carbon is powdered activated carbon of size distribution larger than fly ash size distribution, so that it can be physically separated from the ash and regenerated for reuse.

Carbon is regenerated from previous usage cycle and recycled.

Other desired types of carbon may also be used.

1B. (Dependent)

Same as 1, Solvent is chlorinated hydrocarbon such as dichloromethane.

Same as 1, Solvent is hydrocarbon solvent such as petroleum ether or ligroin or pentane or hexane or toluene or benzene.

Same as 1, Solvent is water.

Same as 1, Solvent is carbon disulfide.

Same as 1, Solvent is a waste solvent.

Same as 1, Solvent is an ether.

Same as 1, Solvent is recycled from previous batch.

Same as 1, Solvent is supercritical solvent such as CO<sub>2</sub>.

Other desired types of Solvents may also be used.

1C. (Dependent)

Same as 1, solution of bromine is applied by stirring the carbon in the bromine solution.

Same as 1, solution of bromine is applied by spraying a solution of molecular bromine in an organic solvent, followed by removal of solvent from the pores by drying the carbon in air or nitrogen.

The bromine may also be applied using other desired techniques.

1D. (Dependent)

Same as 1, removal of solvent is by filtration, centrifugation, settling, and decantation and drying in vacuum, air, or other gas.

Same as 1, when sprayed or minimal volume, removal of solvent is by drying in air, vacuum, or other gas.

The solvent may also be removed using other desired techniques.

1E. (Dependent)

Same as 1, additional substance is iodine, at 1%-10% of the bromine concentration added.

Same as 1, additional substance is hydrohalide (HI, HBr, HCl), etc, 1%-10% of bromine.

Same as 1, additional substance is a compound comprised of a Group V or VI element or combination of Group V or VI with Group VII element, such as SCl<sub>2</sub>, 1-10 wt % of bromine.

A modified carbon sorbent was prepared by reacting the carbon with molecular bromine by contacting the carbon with a gas containing molecular bromine. In one example, the amount of bromine taken up by the carbon ranges from <1 to about 30 g per 100 g of activated carbon, depending on the proportions used.

Contacting is by passing the Br<sub>2</sub> gas through a bed of the carbon.

Bed is ebullated or fluidized.

Bed is moving bed of granules or fibers.

Contacting is by admitting Br<sub>2</sub> gas to a duct through which the carbon is transported from a reservoir to the flue gas duct via an air-driven entrainment method, thus promoting the activity of the carbon in-flight.

Same additives as 1E, except these are added in the gas phase, and added in-flight as in 2 above.

A modified activated carbon sorbent was prepared by reacting the carbon with hydrogen bromide (HBr) by stirring the carbon in a solution of HBr in an organic solvent or in water, followed by removal of the modified carbon from the bulk of solvent and further removal of solvent from the pores by drying the carbon in air or nitrogen. In one example, the amount of bromine taken up by the carbon ranges from <1 to about 30 g per 100 g of activated carbon, depending on the proportions used.

Same dependent clauses as in 1A with regard to carbon forms. Same solutions and treatment as 1B, 1C, 1D.

Same additives as 1E, added into the solution phase or later in the gas phase, and added in-flight as in 2 above.

An activated carbon sorbent was prepared by impregnating hydrogen bromide by passing a gas composition containing hydrogen bromide diluted with nitrogen or air through a fluidized bed or ebullated bed of the carbon. In one example, the amount of bromine taken up by the carbon ranges from <1 to about 30 g per 100 g of activated carbon, depending on the proportions used.

Same dependent clauses as in 1A with regard to carbon forms.

Contacting options are similar to 2.

Sequential treatment of activated carbon with bromine or HBr, followed by another mercury stabilizing reagent to generate a highly reactive bifunctional sorbent, the reagent to include sulfur and selenium species, such as H<sub>2</sub>S, SO<sub>2</sub>, H<sub>2</sub>Se, Se, SeO<sub>2</sub>, CS<sub>2</sub>, P<sub>2</sub>S<sub>5</sub>.

6. Sequential treatment of activated carbon with mercury stabilizing reagent, followed by bromine or HBr to generate a highly reactive bifunctional sorbent, the reagent to include sulfur and selenium species, such as H<sub>2</sub>S, SO<sub>2</sub>, H<sub>2</sub>Se, Se, SeO<sub>2</sub>, CS<sub>2</sub>, P<sub>2</sub>S<sub>5</sub>.

Treatment of a carbon with a Group V or VI element combined with Group VII element, such as PBr<sub>3</sub> or SCl<sub>2</sub>. In one example, the amount of Group V or VI halide is 1-30 wt % of the carbon. The compound is added in vapor phase or in solution (solvent is hydrocarbon, chlorinated hydrocarbon, or other solvent as described in 1B, but not water, since the compound is destroyed in water solution).

The process for preparing the bromine-containing activated carbon sorbent as described in Examples 1-6 and coupled with the injection of the bromine-containing fine-particle sorbent into the contaminated gas stream and subsequent removal of the fine particles of sorbent from the gas stream in a collection device, such as bag filtration of electrostatic precipitator (ESP).

The process of using additives (1-8) in conjunction with sorbents to capture acid gases and other flue gas constituents that block oxidation reactions or consume sorbent sites that would otherwise capture mercury. The additive is a com-

pound comprised of Group I or II elements, such as Ca, Na, and others. These additives of base chemistry may be added to flue gas as a sorbent mixture or co-injected to selectively sorb acid gases or other gas constituents that compete for mercury reactive/sorption sites, thereby improving the effectiveness of activated carbon to capture mercury. In addition, the base additives can augment the treated activated carbon by helping to capture oxidized mercury forms in the flue gas, such as mercuric chloride, or that are produced on the carbon sorbent, such as mercuric bromide, but are released to the gas phase as the sorbent becomes saturated or capacity limited.

The process of preparing a larger-than-normal (>40 μm) sorbent particle size, promoting with the halogen treatment as described in 1-8, using the treated sorbent for capture of mercury by injecting in the flue gas, and finally separating and recovering the sorbent from the ash particles. The larger sorbent size thus will allow easy mechanical/physical separation so that sorbent can be regenerated, recycled, and reused, and the ash can be sold as a low-carbon cementitious byproduct for concrete. The separation can be effected by various methods, such as density (gravity), floatation, or sieving methods.

The process for preparing the bromine-containing activated carbon sorbent as described in Example 1-10, coupled with the direct injection of the slurry of the prepared fine-particle sorbent in the solvent or aqueous phase, so that the aerosol particles of the slurry achieve a high degree of dispersion in the gas stream and evaporation of the solvent in the hot gas occurs rapidly. The amount of slurry added is flow-controlled, and the concentration of particles in the slurry is monitored by optical density measurements prior to injection. Collection of particles is performed.

12. The process for preparing the bromine-containing activated carbon sorbent, as described in Examples 2 and 4, coupled where the fine-particle dispersion of brominated sorbent in the gas stream at the top of the ebullated bed is led to the flue gas or offgas duct where the said dispersion is contacted with mercury-contaminated flue gas or offgas stream. The amount of aerosol dispersion added is controlled by the gas flow to the ebullated bed, and the concentration of particles in the dispersion can be monitored by optical density measurements prior to injection. Collection of particles is performed by the existing particulate-collection equipment.

The process for preparing the bromine-containing activated carbon sorbent bed, coupled with contacting the bed with the mercury-contaminated flue gas or offgas.

The process for preparing the bromine-containing activated carbon sorbent, as described in Examples 2 and 4, or untreated activated carbon, coated on a substrate or as activated carbon material. This material is placed in a moving system that geometrically allows for control of rate of exposure, sorption, and exchange of material in a continuous or semicontinuous manner.

In the sorbent and mercury removal process outlined in paragraphs above, the bromine reagents promote metal oxidation activity by creating cationic or radical character on the carbon edge structure that attracts mercury atoms and extracts electrons from said mercury atoms, resulting in oxidized mercury, which is more easily captured on a sorbent. A similar mechanism applies to oxidation and capture of reduced arsenic and other pollutant species.

The invention relates to the process for the removal of mercury and other pollutant species from gas streams generated during the burning of fossil fuels, such as in a coal-fired utility or synthesis gas from gasification facilities.

This removal process would utilize a sorbent and/or a combination of additives to remove pollutants from the gas stream, which are at the same time interacting with other gas components that result in poisoning or deactivating the sorbent and reducing its capacity or reaction rates with the targeted pollutant species. The present invention provides a cost-effective way to capture the pollutants by utilizing exceptionally active carbon sorbents and promoting mercury sorbent surface reactions, containing a bromide form of the carbon, that capture mercury with high kinetic chemisorption (oxidation) activity, so that capture can occur during contact times of seconds or less. The sorbent does not require in situ activation (induction period) in the gas stream to achieve high activity as do conventional activated carbon sorbents. The reactivity of the sorbent toward the pollutants and the sorption capacity can be regenerated, recycled, and reused.

Burning fossil fuels generates a flue gas that contains mercury (and other trace elements) that was in the coal, plus oxides of sulfur and nitrogen (acid gas emissions) and particulates whose release to the environment must be controlled by use of sorbents, scrubbers, filters, precipitators, and other removal technologies. While control of other elements and/or flue gas pollutants may apply, the discussion provided is focused on mercury. Initially, mercury is released in the elemental form during combustion/gasification, but downstream of the boiler, in the ducts and stack of the combustion system, part of the elemental mercury is oxidized. The amount oxidized depends on the amount of acid gases present in the flue gas and other factors. Amounts of mercury vary with the coal, but a typical concentration of mercury in the stream of combustion gas is about 5 parts per billion (ppb). A pound of mercury or more per day may be emitted in some utilities.

#### Discussion of Sorbent Technologies

Several types of mercury control methods for flue gas have been investigated, including injection of fine sorbent particles into a flue gas duct and passing the flue gas through a sorbent bed. Fine-particle injection sorbents include activated carbon, metal oxide sorbent, sodium sulfide particles (for example, see U.S. Pat. No. 6,214,304), and basic silicate or oxide sorbents (for example, see the Ghorishi reference (Ghorishi, B.; Gullet, B. K. Waste Manage Res. 1993, 16, 582). and Lancia references). When particle injection is employed, the mercury chemisorbed to the sorbent particle is removed from the gas stream in a bag house or ESP and collected along with ash particulates (for example, see U.S. Pat. Nos. 4,889,698, 4,956,162, 5,672,323, 5,827,352, 6,027,551, and 5,505,766). The sulfide and basic silicate and oxide particles are effective only for the oxidized mercury, and the metal oxide sorbents exhibit slower capture kinetics than the carbon particles. Additionally, injection of fine carbon particles into the flue gas stream has been only partially successful in removing mercury, especially elemental mercury, where effective removal of approximately 60% was attained with a baghouse to collect carbon and ash. Even lower removal rates have been observed when using an ESP to collect the carbon, since the contact time of the carbon with the gas is very short.

A major problem with existing carbon injection systems is that the sorbent is initially unreactive, and only after exposure to the flue gas for about 20 minutes does the seasoned sorbent become effective and provide capture of 60% of the mercury in the gas. Consequently, these sorbents must be used in large amounts (high sorbent-to-mercury ratios) to effectively capture the mercury. These sorbents can be relatively expensive and cannot be easily separated from the

ash, regenerated and reused. The collection of carbon in the ash also creates solid waste disposal problems, and the spent sorbent may contaminate the collected ash for use in various applications.

#### 5 Use of Halogens in Mercury Capture

Methodologies for using halogens for the treatment of flue gas have not previously been effective. Halogen is defined as a member of the very active elements comprising Group VII-A of the periodic table. In the molecular elemental halogen form, including F<sub>2</sub>, Cl<sub>2</sub>, Br<sub>2</sub>, and I<sub>2</sub>, the reaction with elemental mercury is not fast enough to result in the formation of oxidized mercury in a coal combustion flue gas with conventional ash control technology. The atomic elemental halogen form, which includes F atom, Cl atom, Br atom, and I atom, is about a million times more reactive to mercury, but the concentrations of these forms are extremely low, and also, therefore, cannot result in oxidation of mercury in a utility flue gas.

A halide is a compound formed from reaction of a halogen with another element or radical. In general, the halide compounds are normally very much less reactive than the molecular halogens, having expended their high chemical potential in forming the low energy halide. The halide is considered a reduced form and cannot therefore oxidize anything by itself. It is for this reason that it is not obvious that a halide-halogen treated activated carbon would be effective at oxidizing elemental mercury and provide effective capture of elemental mercury. In fact, for tests with salts, analytical data show the addition of bromine to an activated carbon or carbon black or soot does form a compound by reacting with the unsaturated groups on the carbon. By applying x-ray photoelectron spectroscopy, it has been determined that bromine or HBr added to carbon black forms chemical compounds within a carbon structure.

A body of theory has been developed from scientific evidence to explain the nature of the promotion effect of the bromine compounds. This principle is illustrated in FIG. 2, which in step 1 shows the reaction of the hydrogen bromide with the unsaturated structure of the activated carbon. This may be a carbene species on the edge of the graphene sheets structures of the carbon. Molecular bromine or a bromine compound reacts to form a similar structure, with a positive carbon that is active for oxidizing the mercury.

We now teach that the formation of the new bromide compound with carbon increases the reactivity of the carbon forms toward mercury and other pollutants. The resulting bromide compound is uniquely suited to facilitate oxidation of the mercury. The effectiveness of the oxidation results from the promotion effect of the halide exerted on the developing positive charge on the mercury during the oxidation, known in the chemical art as a specific catalytic effect. Thus, as the mercury electrons are drawn toward the positive carbon, the halide anion electrons are pushing in from the other side, which stabilizes the positive charge developing on the mercury and lowers the energy requirement for the oxidation process. Bromide is especially reactive, owing to the highly polarizable electrons in the outer 4p orbitals of the ion. Thus, adding HBr or Br<sub>2</sub> to the carbon forms a similar carbon bromide, in which the positive carbon oxidizes the mercury with the assistance of the bromide ion. Prior Art Publications

The earliest patents that relate to mercury capture on a sorbent are actually not for flue gas mercury control but for capture of mercury from air or other gas mixtures on a carbon or other sorbent. These patents were based on a model that recognized the affinity of halogens for mercury,

rather than the formation of a reactive carbon. These patents are discussed below according to the type of halogen used for impregnation.

One patent that teaches a halogen impregnation (Stock, U.S. Pat. No. 1,984,164, issued in 1934) describes the use of activated carbon or other solid impregnated with a halogen for removing Hg from air. The impregnation method is not specified. This seems to be the most general claim with respect to halogen impregnation. All the statements and claims appear to refer to halogen or iodine, but the patent does not appear to address bromides or other halides or bromide compounds or even specifically iodide or an iodine compound. The only example in the description is iodine impregnation. The patent also is restricted to air systems and did not pertain to flue gas systems with reactive acid gases. The description did not assume that the iodine formed a reactive carbon species.

Japanese Patent JP 49-43197 describes the treatment of Hg-contaminated electrolysis cell gas using a metal iodide salt on a support. A similar treatment using a resin impregnated with a metal iodide is described in JP 50-6438. These patents do not appear to represent a carbon bromide compound as specified in this patent application.

Another early patent (Hilgen, U.S. Pat. No. 3,849,267, issued in 1974) describes a method for Hg removal from a gas which claims mixing molecular chlorine ( $\text{Cl}_2$ ) with the gas to be cleaned and passing it through a nonporous sorbent such as glass wool and NaCl (not carbon). This was evidently not an obvious extension of the Stock patent, since a halogen was introduced as part of the gas phase being cleaned.

A later patent (deJong, et al., U.S. Pat. No. 4,196,173, issued in 1980) describes a method for Hg removal in air which claims using a bed of activated carbon impregnated with halogen-only  $\text{Cl}_2$  is specified in the other claims and examples, and it is prepared by flowing the  $\text{Cl}_2$  stream through a carbon bed.

An improved sorbent for mercury in air was patented by Revoir and Jones (U.S. Pat. No. 3,662,523, issued in 1972), in which  $\text{ICl}$  and  $\text{ICl}_3$  vapors were impregnated into the activated carbon. No explanation of the increased activity was provided. Since these compounds are interhalogen compounds, the patent did not infringe Stock.

U.S. Pat. No. 5,891,324 describes an activated carbon containing an acid ( $\text{HCl}$ ,  $\text{H}_2\text{SO}_4$ , or  $\text{H}_3\text{PO}_4$ ) for the removal of mercury contained in a liquid phase, such as would occur in a process steam in the oil industry. In this case, the model presented was that mercury is adsorbed from the liquid into the solid carbon phase at relatively low temperatures.

In U.S. Patent Application 2004/0003716, a method is described for removing mercury from a combustion gas. This method employs an exposure of a finely powdered activated carbon to a molecular bromine gas at an elevated temperature or to  $\text{HBr}$  to produce a sorbent with good mercury removal ability when injected into the flue gas duct. The model for the efficacy of the Nelson sorbent is not clearly stated, so it can be presumed that the reasoning for using bromine is the simple premise that some bromine form will help capture the mercury, as does iodine and chlorine. The methods for incorporation of the bromine in the Nelson application are not the same as with the present invention, and the Nelson method will not produce the identical carbon bromide species that are obtained in the art described in this application. The Nelson method lacks many of the features described in this application that impart exceptional activity to the sorbent in a convenient way, for example, the addition of smaller amount of a second more powerful promoting

agent, the use of facile solvent systems, including aqueous bromine, and the use of in-flight bromine treatment. Additionally, the patent application does not mention regeneration, recycling, or reuse, or the use of moving contactors or larger particle size to facilitate sorbent-ash separation.

#### Embodiments of the Invention

A sorbent that is initially very reactive in oxidizing mercury can be used in very small amounts to achieve high capture efficiencies, thus lowering operation costs and lessening the disposal problem. In addition, further disposal reduction is made possible by recycling and reusing the sorbent that is produced using this technology. The time interval for the mercury and sorbent to interact in a flue gas duct and the subsequent collection of the mercury on the sorbent and ash may be very short—only seconds. This requires the sorbent to have high capacity and be very reactive toward mercury. A sorbent can be utilized in a very finely powdered form (e.g., 1-10  $\mu\text{m}$ ) to minimize mass transfer limitations. But, again, the reactivity should be very high to capture all of the mercury encountered by the fine particles. One feature of this invention is the process to prepare a sorbent containing a bromide compound formed on the carbon structure that provides a sorbent that is highly active on initial contact with the mercury contaminated gas stream, which allows for effective capture of the mercury.

One possible way to do this is to chemically combine molecular bromine from solution with activated carbon (edge sites). X-ray photoelectron spectroscopy established that the addition of bromine formed a chemical compound in the carbon structure. Thus, the sorbent does not represent a molecular bromine halogen form but a new chemically modified carbon structure. This may not occur with the less reactive iodine, where an  $\text{I}_2$ —molecular complex can exist on the carbon basal plane. In the bromine case, it is actually the carbon that oxidizes the mercury. Thus, an entirely new model is presented for the reactivity of the bromine-treated carbon with mercury. The reactive carbon form can be generated by the addition of bromine, hydrogen bromide, or combinations of bromine and other elements as described herein. Chlorine treatment resulted in lower-activity carbons because the chloride anion was less effective in promoting the oxidation by stabilizing the developing positive charge on the mercury in the transition state for oxidation. Based on this model, several innovative, inexpensive, activity-enhancing features have been developed.

It has been demonstrated that addition of an optional second component, in addition to the bromine, results in improved reactivity and capacity for the sorbent, exceeding that of both the untreated carbon and the brominated carbon. The second compound comprises either a second halogen or a compound from a second halogen, such as  $\text{HBr}$ . Thus, in addition to having a reactive carbon form present, the second component generates a Lewis base with greater ability to stabilize the developing positive charge on the mercury. Thus the second component is an element with more polarized electrons (4p and 5p).

Furthermore, we demonstrated that the sorbent can be readily treated with any combination of bromine and the second component in-flight using vapors of these components contacting the very fine carbon particles dispersed in air or other gas stream that conveys the particles to the flue gas duct. There is no particular temperature requirement for this contact. This technology is very simple to implement, so it will result in a great cost savings to the utility using this technology for mercury capture.

A unique, nonobvious technique for preparation of the treated carbon is through combining the treatment system

with the carbon injection system at the end-use site. With this technique, the halogen is introduced to the carbon-air mixture in the transport line (or other part of the sorbent storage and injection system). Benefits over current concepts to treat sorbents off-site include the following:

Capital equipment costs at a treatment facility are eliminated.

Costs to operate the treatment facility are eliminated.

There are no costs for transporting carbon and additive to a treatment facility.

This process uses existing hardware and operation procedures.

This technology ensures that the sorbent is always fresh, and thus, more reactive.

No new handling concerns are introduced.

There are no costs for removing carbon from treatment system.

This process allows rapid on-site tailoring of additive-sorbent ratios in order to match the requirements of flue gas changes, such as needed when changing fuels or reducing loads, thus further optimizing the economics.

This technology reduces the amount of spent sorbents that are disposed.

With the foregoing and other features in view, there is provided, in accordance with the invention, a process for preparing and regenerating carbon sorbents whose activity for mercury capture is promoted by the addition of bromine to the carbon structure.

The invention applies to use of a sorbent in a powdered form that has been injected into a flue gas stream before or after ash particulates have been removed. Examples of the composition of the sorbent are a powdered modified activated carbon prepared by adding  $\text{Br}_2$  or  $\text{HBr}$  plus a second optional component. Alternatively, the sorbent is on a moving contactor consisting of particles or fibers containing the compositions listed in the previous sentence. Either type can be regenerated; the poisoning contaminants from the flue gas are removed and an inexpensive promoting agent added to restore mercury sorption activity. This process of promoting the activity of the carbon itself contrasts with the earlier, more expensive art of adding a reagent (such as peroxide, gold, triiodide, etc.) to the sorbent. The activated carbon sorbent treated with bromine and/or the other components is noncorrosive.

Detailed examples of sorbent regeneration techniques are described in co-pending, commonly-owned PCT patent application No. PCT/US04/12828, titled "PROCESS FOR REGENERATING A SPENT SORBENT", which is incorporated by reference herein.

Although the invention is described herein as a sorbent material, it is nevertheless not intended to be limited to the details described, since various modifications and structural changes may be made therein without departing from the spirit of the invention and within the scope and range of equivalents of the claims.

The construction and method of operation of the invention, however, together with additional objects and advantages thereof will be best understood from the following description of specific exemplary embodiments.

FIG. 6 is a block diagram illustrating the use of the invention in a coal fueled facility. Of course, the invention can also be used in any other desired type of facility. FIG. 6 shows a boiler for burning pulverized coal. The facility utilizes various devices to clean the exhaust of the boiler. In this example, a baghouse or ESP is used to collect particulates in the exhaust. A scrubber and sorbent bed are also used to remove undesired constituents from the flue gas stream,

before being fed to the stack. In the example shown, the sorbent is injected into the flue gas after the boiler. The additive can be injected where desired (e.g., before, after, or within the boiler).

Another advantage of the present invention relates to the use of a feedback system to more efficiently utilize the invention. Where possible, the mercury control technology of the present invention will utilize measurement of mercury emissions as feedback to assist in control of the sorbent injection rate. Tighter control on the sorbent levels in this way will ensure mercury removal requirements are met with the minimal sorbent requirements and therefore the associated costs will be minimized. In one example, the emissions are measured at the stack.

Carbon Sorbent

Reactions of halogens and acidic species with the basic binding sites on the activated carbon sorbent create sites for oxidizing mercury. Other metal ions, such as boron, tin, arsenic, gallium, Sb, Pb, Bi, Cd, Ag, Cu, Zn, or other contaminants, will also react with the oxidation sites generated on the carbon.

According to our model, adding the bromine from the bromine reagent or a proton from a hydrogen halide acid to a basic carbene site on the carbon edge structure forms a carbocation that accept electrons from the neutral mercury atom forming the oxidized mercury species that is bound to the sorbent surface. The reactive site may also generate reactive bromine radicals or carbon radicals at the active sites on the carbon. Thus, the activated carbon serves to stabilize the bromine, yet provides a highly reactive bromine-containing reagent that can oxidize the mercury and promote its capture on the activated carbon. The sorbent that contains bromine is expected to be more reactive than the corresponding sorbent containing chlorine and much less expensive than the sorbent containing iodine.

A bench-scale procedure based on the above description was used to test the initial activities and capacities of several powdered carbon sorbents, including the bromine-containing activated carbons prepared from a commercially available sorbent and an aerogel carbon film sorbent, as well as the original precursor carbons for comparison. Bromine-treated carbons were prepared by impregnation of the powdered activated carbon precursors in a stirred solution of bromine in carbon tetrachloride or methylene chloride, or alternatively, in an aqueous solution of  $\text{HBr}$ , followed by drying in air at ambient temperature and drying in an oven at  $100^\circ\text{C}$ . in air or nitrogen. Bromine-treated carbons were also prepared by impregnating bromine from the gas phase by passing the gas through a rotating dry bed of the activated carbon precursor. Adding a second component to the solution was demonstrated to improve the capacity of the sorbent.

The carbons were initially tested in a heated bed, where a synthetic flue gas stream containing elemental mercury ( $11\ \mu\text{g}/\text{m}^3$ ) was passed through the bed. Concentrations of total and elemental Hg in the effluent gas were determined using a Sir Galahad mercury CEM. The powdered sorbent was supported on a quartz filter during the test, and the other sorbents were tested as a triple layer.

A comparison of the original commercial-grade powdered carbon sorbent with the sorbent after it has been treated with 0.1 N  $\text{HBr}$ , collecting the powder by centrifugation and drying, revealed that the mercury capture activity is increased from an initial capture efficiency of about 50% of the Hg in the inlet to 100% capture. A comparison of the sorbent after subsequent regeneration with  $\text{HBr}$  indicates that it not only captures mercury at the same level as before

(100% capture) but is enhanced such that its capacity is prolonged by several minutes. Similar results were obtained with the carbon film and carbon fiber sorbents by treatment with molecular bromine in solution or in dry beds as described above.

An activated carbon sorbent was prepared by treating the carbon by impregnating molecular bromine from a gas composition containing molecular bromine by flowing the gas through a liquid bromine reservoir in series with a fluidized bed of ebullated bed of the carbon. The amount of bromine taken up by the carbon ranges (in one example) from <1 to about 30 g per 100 g of activated carbon, depending on the proportions used.

In one exemplary test conducted at a facility fired with lignite coal, the flue gas phase mercury (elemental) concentration was between 10 and 11  $\mu\text{g}/\text{m}^3$ . The ash and injected carbons were collected in the baghouse at 350E to 375EF. Injection of commercial-grade activated carbon powder (untreated) at a rate of 1.0 lb/Macf resulted in mercury effluent concentrations of 3.8-4.2  $\mu\text{g}/\text{m}^3$  (representing 62%-58% removal of the mercury from the gas), and at 2.0 lb/Macf, gave 74%-71% removal. Injection of the bromine-treated carbon at 1.0 lb/Macf resulted in 73%-69% removal and at 2.0 lb/Macf gave 86%-84% removal. Thus, a significant increase in the mercury capture was exhibited during use of the bromine-treated carbon.

#### Addendum: Other References to Hg Sorption Sorbent Beds with Particulate Removal

Carbon beds have also been utilized for mercury capture in flue gas. The German Patent 34 26 059 describes the use of a very thick carbon bed for treatment of flue gases containing polyhalogenated compounds. Although the system employed at Dusseldorf would also have the potential for Hg removal (for example, see the Streng reference), it is not very practical to use such a thick bed. Spent sorbent is burned and not regenerated. The carbons are not pretreated.

The GE-Mitsui-BF system (Tsuji, K.; Shiraiishi, I.; Dague, R. F. Proceedings, Sixth International Symposium, Air & Water Management Assoc., New Orleans, La., Mar. 10-12, 1993) employs a recirculating carbon bed, where mercury is removed along with acid gases (as ammonium salts) and the carbon is regenerated at high temperatures where ammonium sulfate is decomposed to  $\text{SO}_2$  and  $\text{N}_2$  and mercury is converted to the elemental form, which desorbs from the sorbent. Attrition of the sorbent results in a significant sorbent cost. The carbons are not pretreated.

#### Sorbent Injection after Particulate Removal

A process of injecting manganese oxide sorbent particles is described in U.S. Patent Application 2002/0150516. Regeneration is claimed by removal of spent oxide particles from the reaction zone and rinsing with dilute aqueous acid.

Of particular interest in designing a mercury control process is to use the sorbent downstream of a particulate control device so the sorbent is not highly diluted with the ash particles. The sorbent could then be more easily regenerated and recycled. The prior art teaches several examples of this type of configuration and sorbent processing.

U.S. Pat. No. 5,607,496 teaches the oxidation of mercury on a metal oxide sorbent bed and subsequent absorption to sorbent. The sorbent bed follows the particulate-removal equipment and, thus, the gas still contains the  $\text{SO}_x$  and  $\text{NO}_x$ , which react with the metal oxide sorbent to form the metal sulfates, which poison the bed. High temperatures are proposed to regenerate the bed. However, Hg is only partially removed from the sorbent at temperatures up to 500° C. The sorbents do not work effectively after regeneration using this

technique; the problem may be that manganese sulfate formed during the sorption cycle does not completely decompose back to an active manganese oxide form.

U.S. Pat. No. 6,383,981 describes a fixed  $\text{MnO}_2$  or  $\text{Fe}_2\text{O}_3$  bed for removal of Hg from a hydrocarbon stream. No regeneration method appears to be included.

A recent U.S. Patent application (2001/0003116) describes the regeneration of a plate or honeycomb material composed of transition metal oxides that was used for sorption of mercury in flue gas. The claimed process involves heating the sorbent in a reducing gas stream to remove poisons, followed by impregnation with a polyfunctional complex-forming reagent containing the catalyst active component to restore mercury capture capacity. The first of these steps can remove the mercury, but it is unclear whether it actually removes the sulfate poison. The second of these steps is rather expensive, because one is actually reconstituting the reagent on the sorbent.

Porous beds containing a mercury oxidizing reagent on a solid support are described in several patents for removal of mercury from gas streams. These include peroxomonosulfate (for example, see U.S. Pat. No. 4,786,483), triiodide or other mixed halogens (for example, see U.S. Pat. Nos. 3,194,629; 3,662,523), or sulfur (for example, see U.S. Pat. Nos. 3,194,629, 4,101,631, 4,708,853, 6,258,334). The reagent material is destroyed either by reaction with the flue gas during sorption or by attempts to regenerate the sorbent; there is no way to regenerate these sorbents, except by reimpregnation of the expensive reagent.

Amalgamating noble metals (gold, silver) on a suitable support can be regenerated by microwave heating (for example, see U.S. Pat. No. 6,136,072), but they are expensive and not especially active for sorption in flue gas.

#### Hg Sorbents for Air or Natural Gas Treatment

Melkersson (U.S. Pat. No. 3,786,619) described a Hg sorbent comprising  $\text{SeO}_2$  or  $\text{SeS}_2$  for air treatment. This method did not appear to employ a carbon support or halide.

Yan (U.S. Pat. No. 4,814,152) described a Hg sorbent comprising elemental sulfur and a metal catalyst on a carbon support. This method did not appear to employ a halide.

Attia (U.S. Patent 65/080,281) described a sorbent for mercury and a variety of other contaminants comprising an inorganic aerogel composition. This method did not appear to employ a carbon support or halide.

#### FOLLOWING IS A LIST OF VARIOUS BACKGROUND REFERENCES

Lancia, A.; Musmarra, D.; Pepe, F.; Volpicelli, G. *Combust. Sci. & Technol.* 1993, 93, 277.

Streng, S.; Kassebohm, B. *Fuel Proc. Technol.* 1994, 39, 431.

U.S. Pat. No. 6,214,304 Rosenthal

U.S. Pat. No. 4,889,698 Moller

U.S. Pat. No. 4,956,162 Smith

U.S. Pat. No. 5,672,323 Bhat.

U.S. Pat. No. 5,827,352 Altman

U.S. Pat. No. 6,027,551 Hwang

U.S. Pat. No. 5,505,766 Chang

U.S. Pat. No. 5,607,496 Brooks

U.S. Pat. No. 6,383,981 Blankenship

U.S. Pat. No. 4,786,483 Audeh

U.S. Pat. No. 3,194,629 Dreibelbis, et al

U.S. Pat. No. 4,101,631 Ambrsini, et al

U.S. Pat. No. 3,662,523 Revoir

U.S. Pat. No. 4,708,853 Matviya

U.S. Pat. No. 6,258,334 Gadkaree

U.S. Pat. No. 6,136,072 Sjostrom  
 U.S. Patent Application 2002/0150516  
 U.S. Patent Application 2001/0003116 Neufert

While the preferred embodiments of the invention have been shown and described, modifications thereof can be made by one skilled in the art without departing from the spirit and teachings of the invention. The embodiments described herein are exemplary only and are not intended to be limiting. Many variations and modifications of the invention disclosed herein are possible and are within the scope of the invention. Accordingly, the scope of protection is not limited by the description set out above, but is only limited by the claims which follow, that scope including all equivalents of the subject matter of the claims.

The examples provided in the disclosure are presented for illustration and explanation purposes only and are not intended to limit the claims or embodiment of this invention. While the preferred embodiments of the invention have been shown and described, modifications thereof can be made by one skilled in the art without departing from the spirit and teachings of the invention. Process criteria, equipment, and the like for any given implementation of the invention will be readily ascertainable to one of skill in the art based upon the disclosure herein. The embodiments described herein are exemplary only and are not intended to be limiting. Many variations and modifications of the invention disclosed herein are possible and are within the scope of the invention. Use of the term "optionally" with respect to any element of the invention is intended to mean that the subject element is required, or alternatively, is not required. Both alternatives are intended to be within the scope of the invention.

The discussion of a reference in the Background is not an admission that it is prior art to the present invention, especially any reference that may have a publication date after the priority date of this application. The disclosures of all patents, patent applications, and publications cited herein are hereby incorporated herein by reference in their entirety, to the extent that they provide exemplary, procedural, or other details supplementary to those set forth herein.

Although the invention is described herein as a promoted sorbent material and associated processes for its preparation and use, it is nevertheless not intended to be limited to the details described, since various modifications and structural changes may be made therein without departing from the spirit of the invention and within the scope and range of equivalents of the claims.

What is claimed is:

1. A method of separating mercury from a mercury-containing gas, the method comprising:

combusting coal in a combustion chamber, to provide the mercury-containing gas, wherein the mercury-containing gas comprises a halogen or halide promoter comprising HBr, Br<sup>-</sup>, or a combination thereof, wherein the coal comprises added Br<sub>2</sub>, HBr, Br<sup>-</sup>, or a combination thereof, added to the coal upstream of the combustion chamber, or

the combustion chamber comprises added Br<sub>2</sub>, HBr, Br<sup>-</sup>, or a combination thereof;

injecting a sorbent material comprising activated carbon into the mercury-containing gas downstream of the combustion chamber;

contacting mercury in the mercury-containing gas with the sorbent, to form a mercury/sorbent composition;

separating the mercury/sorbent composition from the mercury-containing gas, to form a cleaned gas;

monitoring the mercury content of the cleaned gas; and controlling, in response to the monitored mercury content of the cleaned gas, an injection rate of injecting the sorbent into the mercury-containing gas, the sorbent composition, or a combination thereof, so that the mercury content of the cleaned gas is maintained at or below a desired level.

2. The method of claim 1, comprising removing greater than 70 wt % of the mercury in the mercury-containing gas.

3. The method of claim 1, comprising removing greater than 70 wt % of the mercury in the mercury-containing gas on the sorbent.

4. The method of claim 1, wherein the sorbent in the mercury-containing gas comprises about 1 g to about 30 g of the halogen or halide promoter per 100 g of the sorbent material.

5. The method of claim 1, wherein the combustion chamber comprises the halogen or halide promoter.

6. The method of claim 1, wherein the coal comprises added Br<sub>2</sub>, HBr, Br<sup>-</sup>, or a combination thereof, added to the coal upstream of the combustion chamber.

7. The method of claim 1, wherein the promoter is contacted with the sorbent in vapor form, gaseous form, liquid form, or in an organic solvent.

8. The method of claim 1, further comprising injecting a secondary material into the mercury-containing gas downstream of the combustion chamber.

9. The method of claim 8, wherein the secondary material comprises a halogen, a compound derived from a halogen, a hydrohalide, a compound comprising a Group V or Group VI element and a molecular halogen, or a combination thereof.

10. The method of claim 1, wherein the sorbent material injected into the mercury-containing gas further comprises a non-carbon sorbent material.

11. The method of claim 10, wherein the non-carbon sorbent material comprises at least one of a porous felsic material, a vesicular felsic material, a porous basaltic material, a vesicular basaltic material, a clay-based compound, an alkaline compound, a calcium hydroxide compound, a sodium acetate compound, and a bicarbonate compound.

12. The method of claim 1, wherein the activated carbon comprises powdered activated carbon, granular activated carbon, or a combination thereof.

13. The method of claim 1, wherein the sorbent material injected into the mercury-containing gas is substantially free of halogen and halide promotion.

14. The method of claim 1, wherein the sorbent material injected into the mercury-containing gas is a promoted sorbent obtained by contacting a base sorbent with another halogen or halide promoter.

15. The method of claim 1, wherein the combustion chamber comprises a boiler.

16. The method of claim 1, wherein the mercury-containing gas is a flue gas.

17. The method of claim 1, wherein the injection of the sorbent material into the mercury-containing gas occurs upstream of an air pre-heater.

18. The method of claim 1, wherein the injection of the sorbent material into the mercury-containing gas occurs upstream of a particulate separator or a scrubber.

19. The method of claim 1, wherein the coal comprises added halide sorbent enhancement additive.

20. The method of claim 1, wherein the combustion chamber comprises added Br<sub>2</sub>, HBr, Br<sup>-</sup>, or a combination thereof.

21. The method of claim 1, wherein the coal comprises added sorbent enhancement additive that comprises Br<sup>-</sup>.

35

22. The method of claim 21, wherein the sorbent enhancement additive comprises a bromide compound.

23. A method of separating mercury from a mercury-containing gas, the method comprising:

combusting coal in a combustion chamber, to provide the mercury-containing gas, wherein the mercury-containing gas comprises a halogen or halide promoter comprising HBr, Br<sup>-</sup>, or a combination thereof, wherein the coal comprises added Br<sub>2</sub>, HBr, Br<sup>-</sup>, or a combination thereof, added to the coal upstream of the combustion chamber, or the combustion chamber comprises added Br<sub>2</sub>, HBr, Br<sup>-</sup>, or a combination thereof, or

injecting a sorbent material comprising activated carbon into the mercury-containing gas downstream of the combustion chamber;

contacting mercury in the mercury-containing gas with the sorbent, to form a mercury/sorbent composition; and

separating the mercury/sorbent composition from the mercury-containing gas, to form a cleaned gas.

24. A method of separating mercury from a mercury-containing gas, the method comprising:

combusting coal in a combustion chamber, to provide the mercury-containing gas, wherein the mercury-containing gas comprises a halogen or halide promoter comprising HBr, Br<sup>-</sup>, or a combination thereof, wherein the coal comprises added Br<sub>2</sub>, HBr, Br<sup>-</sup>, or a combination thereof, added to the coal upstream of the combustion chamber, or

the combustion chamber comprises added Br<sub>2</sub>, HBr, Br<sup>-</sup>, or a combination thereof, or

injecting a sorbent material comprising activated carbon into the mercury-containing gas downstream of the combustion chamber such that the activated carbon reacts with the halogen or halide promoter in the mercury-containing gas to form a promoted sorbent;

contacting mercury in the mercury-containing gas with the promoted sorbent, to form a mercury/sorbent composition;

separating the mercury/sorbent composition from the mercury-containing gas, to form a cleaned gas;

monitoring the mercury content of the cleaned gas; and controlling, in response to the mercury content of the cleaned gas,

an injection rate of injecting the sorbent into the mercury-containing gas,

36

a rate of addition to the coal or the combustion chamber of the added Br<sub>2</sub>, HBr, the bromide compound, or a combination thereof, or

so that the mercury content of the cleaned gas is maintained at or below a desired level.

25. A method of separating mercury from a mercury-containing gas, the method comprising:

combusting coal in a combustion chamber, to provide the mercury-containing gas, wherein the coal comprises added Br<sub>2</sub>, HBr, a bromide compound, or a combination thereof, added to the coal upstream of the combustion chamber, or the combustion chamber comprises added Br<sub>2</sub>, HBr, a bromide compound, or a combination thereof, or

injecting a sorbent material comprising activated carbon into the mercury-containing gas downstream of the combustion chamber;

contacting mercury in the mercury-containing gas with the sorbent, to form a mercury/sorbent composition; and

separating the mercury/sorbent composition from the mercury-containing gas, to form a cleaned gas.

26. The method of claim 25, wherein the coal comprises the added Br<sub>2</sub>, HBr, the bromide compound, or a combination thereof, added to the coal upstream of the combustion chamber.

27. The method of claim 25, wherein the combustion chamber comprises the added Br<sub>2</sub>, HBr, the bromide compound, or a combination thereof.

28. The method of claim 25, further comprising monitoring the mercury content of the cleaned gas; and controlling, in response to the mercury content of the cleaned gas,

an injection rate of injecting the sorbent into the mercury-containing gas,

a rate of addition to the coal or the combustion chamber of the added Br<sub>2</sub>, HBr, the bromide compound, or a combination thereof, or

so that the mercury content of the cleaned gas is maintained at or below a desired level.

29. The method of claim 25, wherein the mercury-containing gas comprises about 1 g to about 30 g of the element bromine per 100 g of the sorbent.

30. The method of claim 25, wherein the mercury/sorbent composition comprises the element bromine, the sorbent material, and mercury.

\* \* \* \* \*