



US 20060022277A1

(19) **United States**

(12) **Patent Application Publication**

Kavalieros et al.

(10) **Pub. No.: US 2006/0022277 A1**

(43) **Pub. Date: Feb. 2, 2006**

(54) **PLANARIZING A SEMICONDUCTOR
STRUCTURE TO FORM REPLACEMENT
METAL GATES**

(21) Appl. No.: **10/900,582**

(22) Filed: **Jul. 28, 2004**

(76) Inventors: **Jack Kavalieros**, Portland, OR (US);
Justin K. Brask, Portland, OR (US);
Mark L. Doczy, Beaverton, OR (US);
Uday Shah, Portland, OR (US); **Chris
E. Barns**, Portland, OR (US); **Matthew
V. Metz**, Hillsboro, OR (US); **Suman
Datta**, Beaverton, OR (US); **Robert S.
Chau**, Beaverton, OR (US)

Publication Classification

(51) **Int. Cl.**
H01L 21/8238 (2006.01)
H01L 29/94 (2006.01)
(52) **U.S. Cl.** **257/369; 438/199**

(57) **ABSTRACT**

A sacrificial gate structure, including nitride and fill layers, may be replaced with a metal gate electrode. The metal gate electrode may again be covered with a nitride layer covered by a fill layer. The replacement of the nitride and fill layers may reintroduce strain and provide an etch stop.

Correspondence Address:
TROP PRUNER & HU, PC
8554 KATY FREEWAY
SUITE 100
HOUSTON, TX 77024 (US)

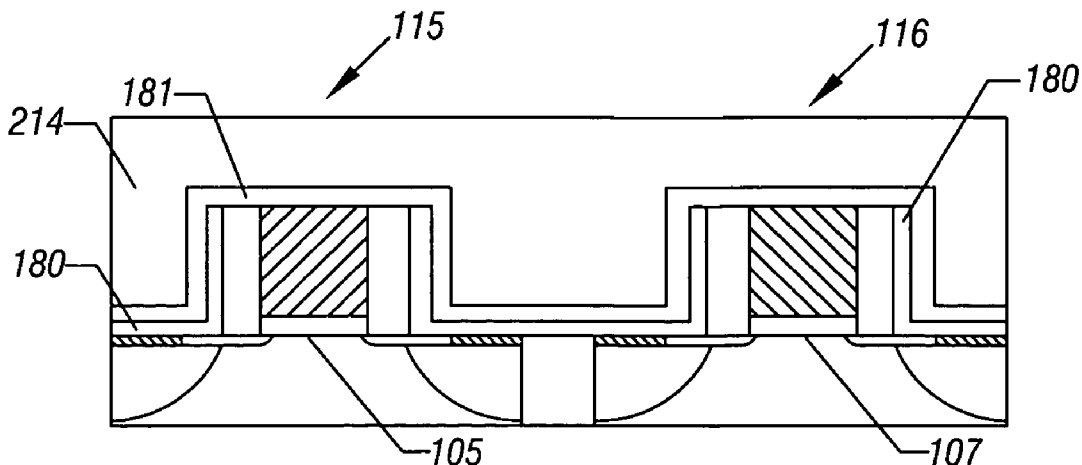



FIG. 1A

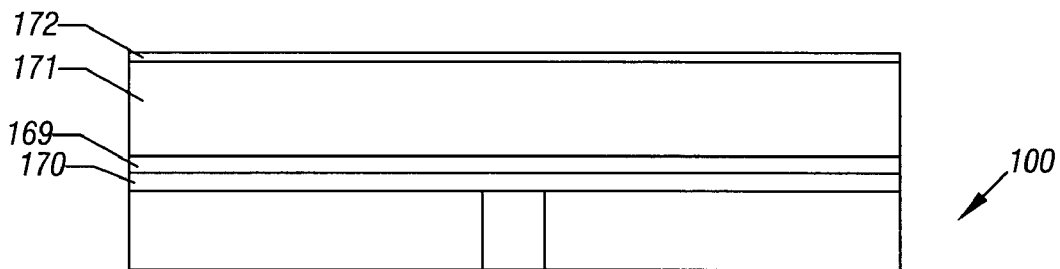

FIG. 1B

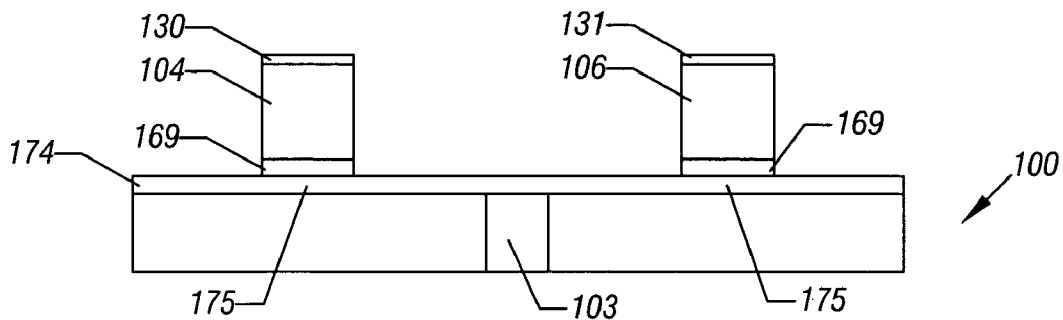

FIG. 1C

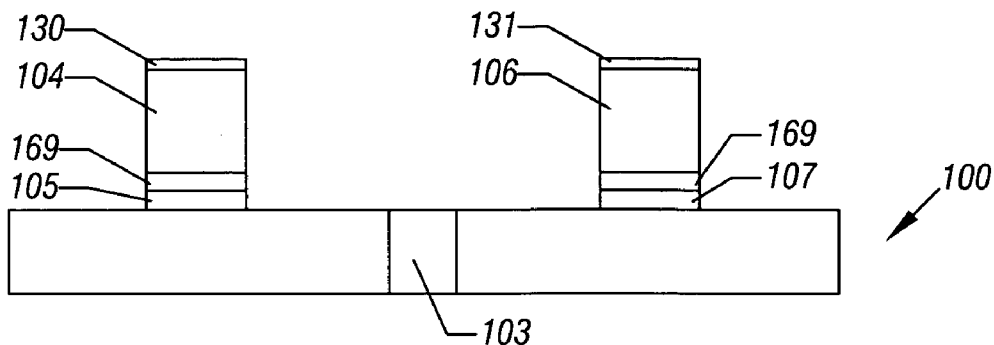

FIG. 1D

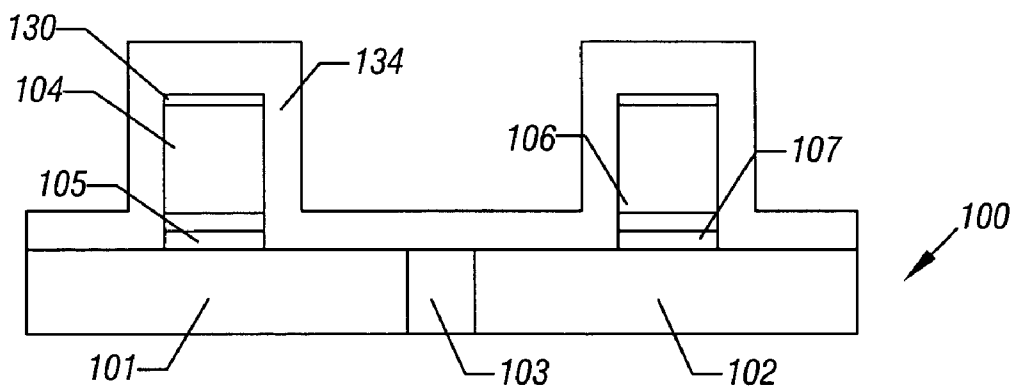

FIG. 1E

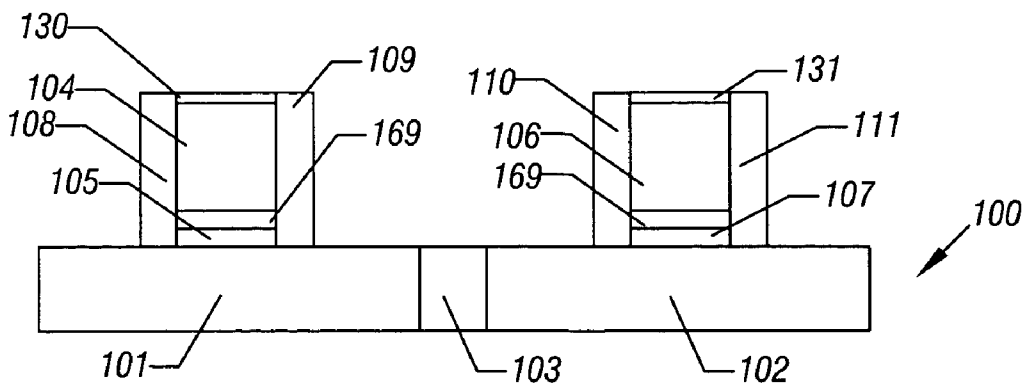

FIG. 1F

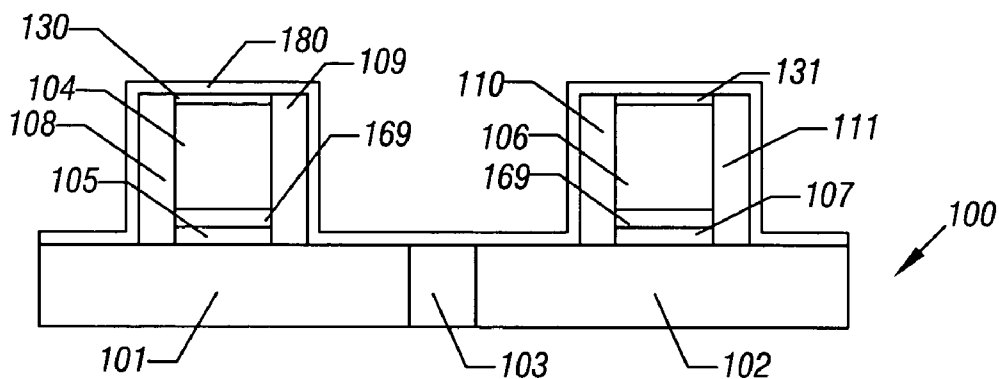

FIG. 1G

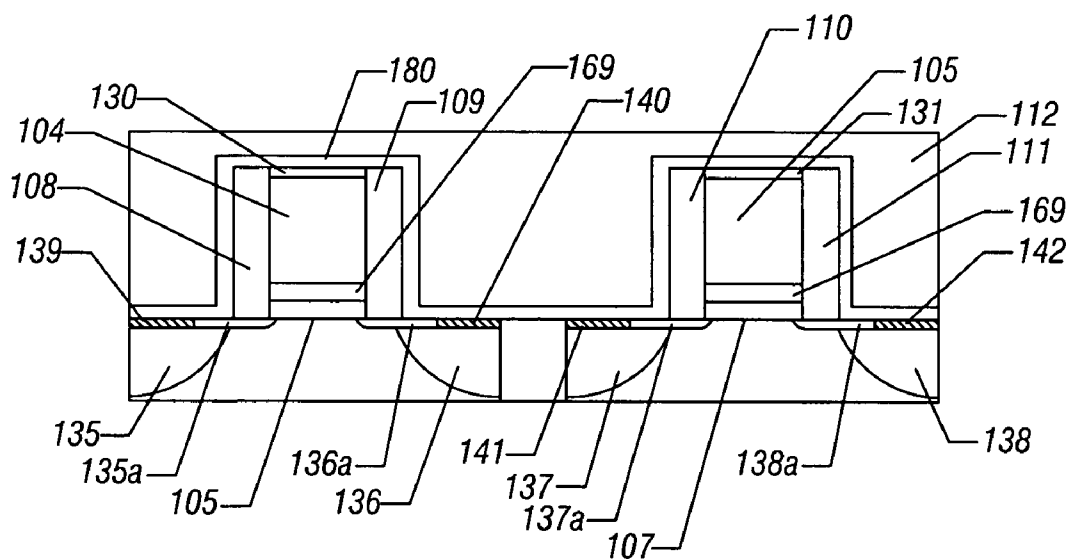

FIG. 1H

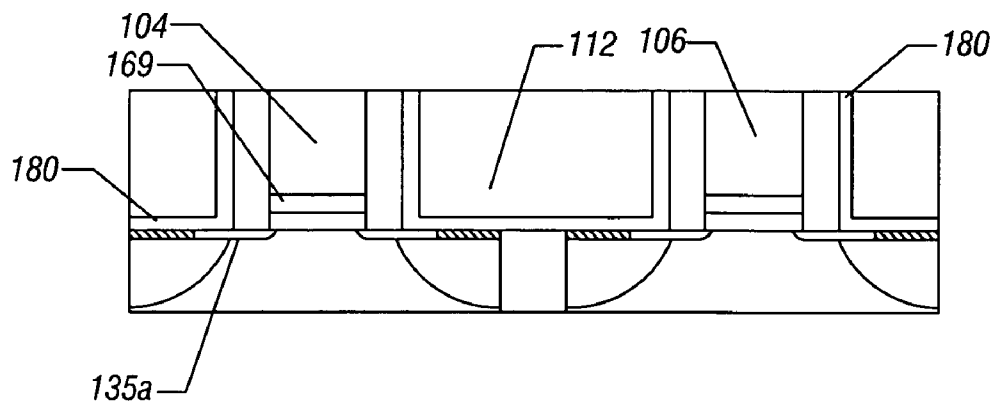

FIG. 1I

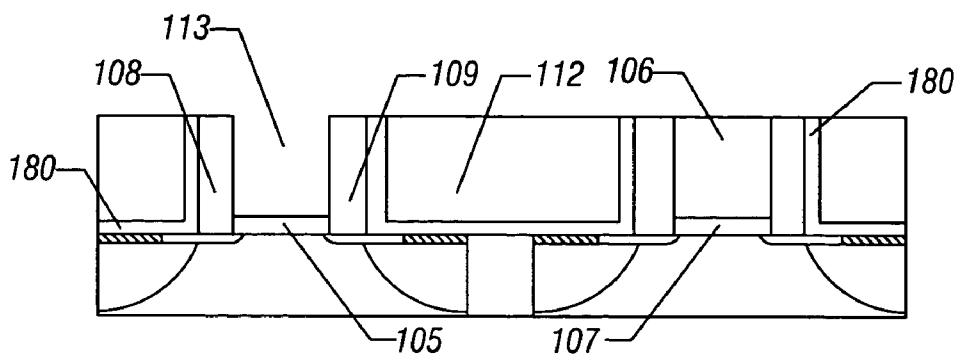

FIG. 1J

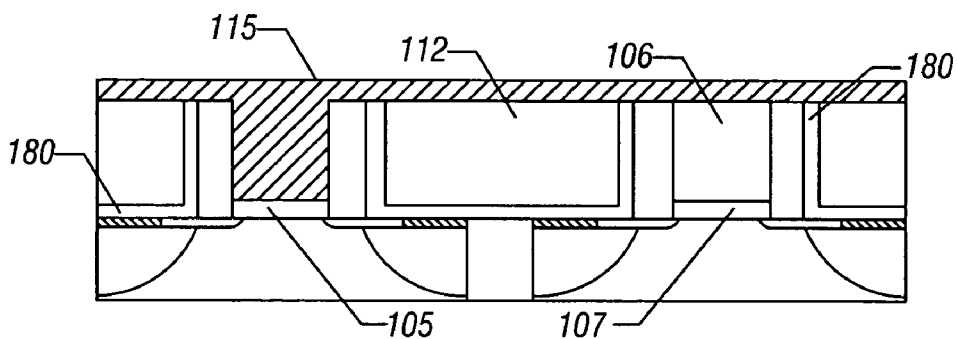

FIG. 1K

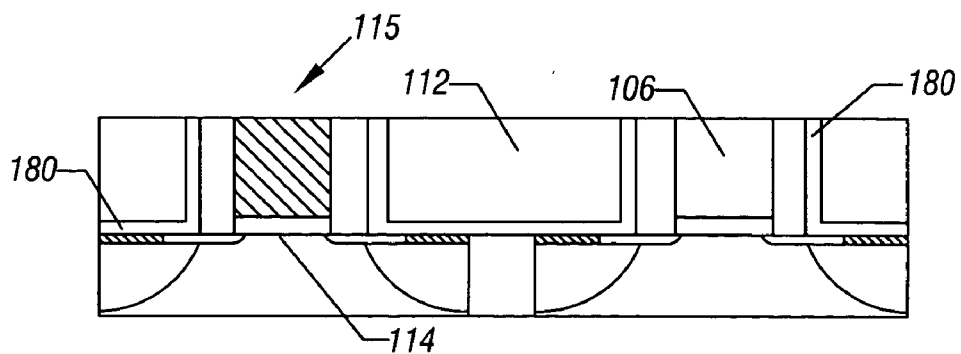

FIG. 1L

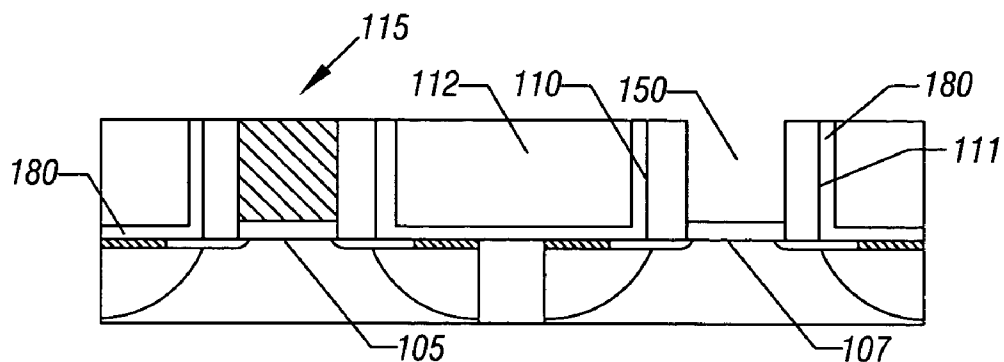

FIG. 1M

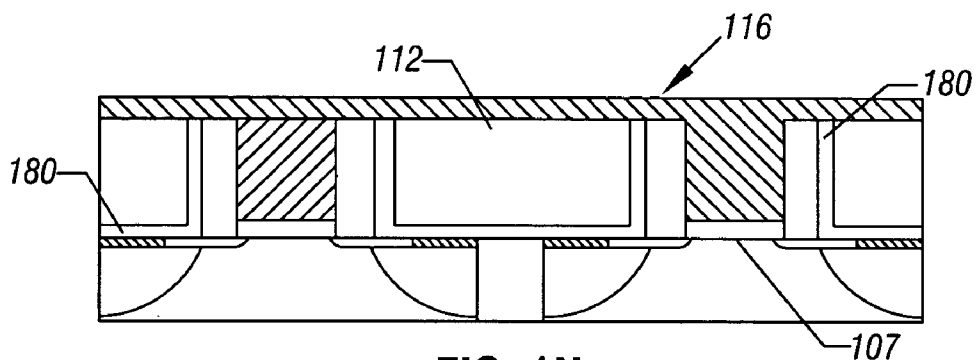

FIG. 1N

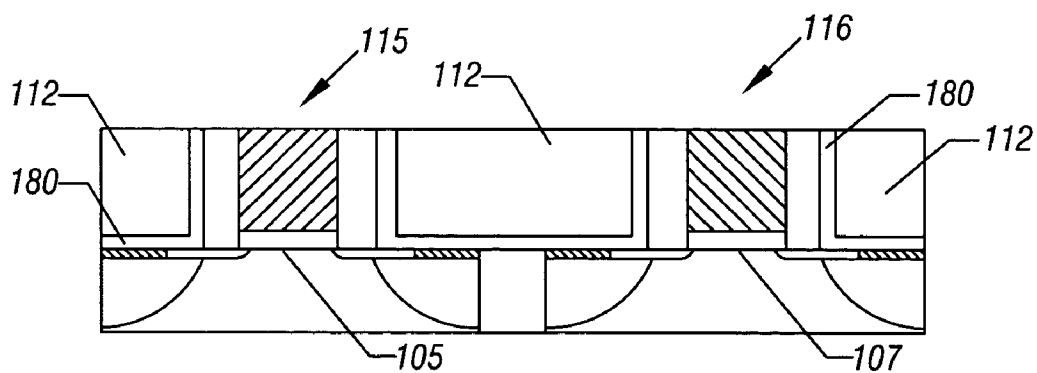

FIG. 10

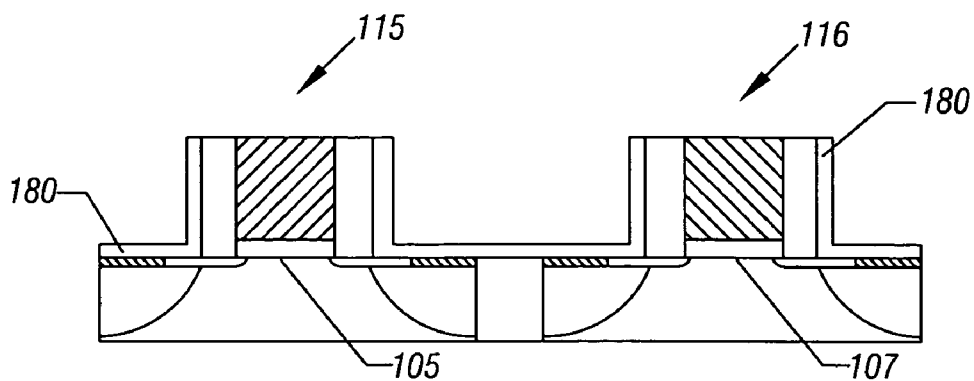

FIG. 1P

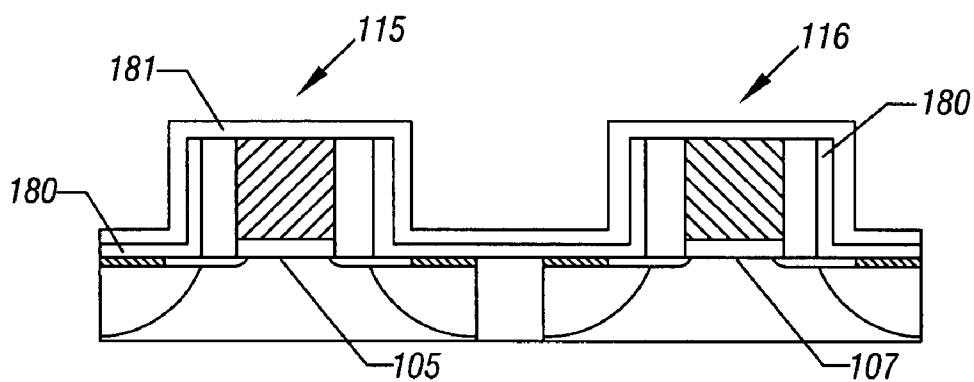

FIG. 1Q

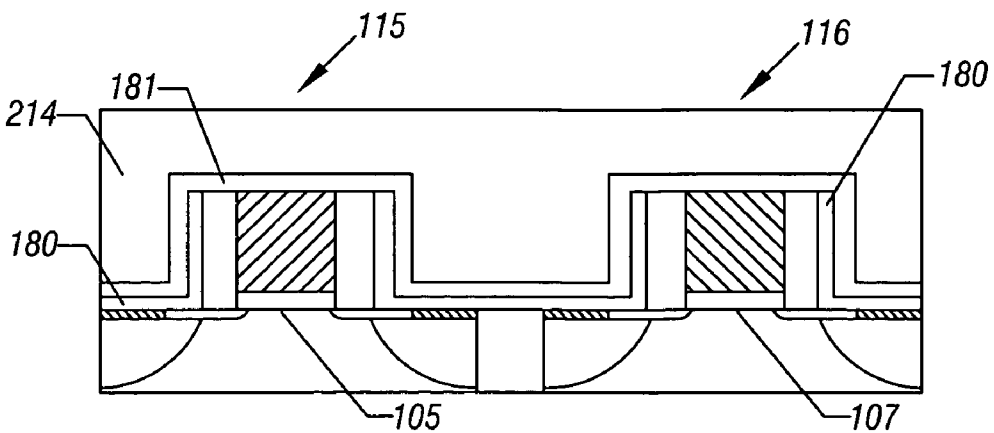

FIG. 1R

PLANARIZING A SEMICONDUCTOR STRUCTURE TO FORM REPLACEMENT METAL GATES

BACKGROUND

[0001] The present invention relates to methods for making semiconductor devices, in particular, semiconductor devices with metal gate electrodes.

[0002] MOS field-effect transistors with very thin gate dielectrics made from silicon dioxide may experience unacceptable gate leakage currents. Forming the gate dielectric from certain high dielectric constant (K) dielectric materials, instead of silicon dioxide, can reduce gate leakage. As used herein, high-k dielectric means having a dielectric constant higher than 10. When, however, a high-k dielectric film is initially formed, it may have a slightly imperfect molecular structure. To repair such a film, it may be necessary to anneal it at a relatively high temperature.

[0003] Because such a high-k dielectric layer may not be compatible with polysilicon, it may be desirable to use metal gate electrodes in devices that include high-k gate dielectrics. When making a CMOS device that includes metal gate electrodes, it may be necessary to make the NMOS and PMOS gate electrodes from different materials. A replacement gate process may be used to form gate electrodes from different metals. In that process, a first polysilicon layer, bracketed by a pair of spacers, is removed selectively to a second polysilicon layer to create a trench between the spacers. The trench is filled with a first metal. The second polysilicon layer is then removed, and replaced with a second metal that differs from the first metal.

[0004] Thus, there is a need for alternate ways to form replacement metal gate electrodes.

BRIEF DESCRIPTION OF THE DRAWINGS

[0005] FIGS. 1A-1R represent cross-sections of structures that may be formed when carrying out an embodiment of the present invention.

[0006] Features shown in these figures are not intended to be drawn to scale.

DETAILED DESCRIPTION

[0007] FIGS. 1A-1R illustrate structures that may be formed when carrying out an embodiment of the method of the present invention. Initially, high-k gate dielectric layer 170 and a sacrificial metal layer 169 are formed on substrate 100, generating the FIG. 1A structure. Alternatively, although not shown, a dummy gate dielectric (e.g. a 20-30 Angstroms SiO₂ layer) may be carried through this portion of the flow and replaced by a high K dielectric at the time of the replacement gate process. Substrate 100 may comprise a bulk silicon or silicon-on-insulator substructure. Alternatively, substrate 100 may comprise other materials—which may or may not be combined with silicon—such as: germanium, indium antimonide, lead telluride, indium arsenide, indium phosphide, gallium arsenide, or gallium antimonide. Although a few examples of materials from which substrate 100 may be formed are described here, any material that may serve as a foundation upon which a semiconductor device may be built falls within the spirit and scope of the present invention.

[0008] Some of the materials that may be used to make high-k gate dielectric layer 170 include: hafnium oxide, hafnium silicon oxide, lanthanum oxide, lanthanum aluminum oxide, zirconium oxide, zirconium silicon oxide, tantalum oxide, titanium oxide, barium strontium titanium oxide, barium titanium oxide, strontium titanium oxide, yttrium oxide, aluminum oxide, lead scandium tantalum oxide, and lead zinc niobate. Particularly preferred are hafnium oxide, zirconium oxide, titanium oxide and aluminum oxide. Although a few examples of materials that may be used to form high-k gate dielectric layer 170 are described here, that layer may be made from other materials that serve to reduce gate leakage. The layer 170 has a dielectric constant higher than 10 and from 15 to 25 in one embodiment of the present invention.

[0009] High-k gate dielectric layer 170 may be formed on substrate 100 using a conventional deposition method, e.g., a conventional chemical vapor deposition (“CVD”), low pressure CVD, or physical vapor deposition (“PVD”) process. Preferably, a conventional atomic layer CVD process is used. In such a process, a metal oxide precursor (e.g., a metal chloride) and steam may be fed at selected flow rates into a CVD reactor, which is then operated at a selected temperature and pressure to generate an atomically smooth interface between substrate 100 and high-k gate dielectric layer 170. The CVD reactor should be operated long enough to form a layer with the desired thickness. In most applications, high-k gate dielectric layer 170 may be less than about 60 Angstroms thick, for example, and, in one embodiment, between about 5 Angstroms and about 40 Angstroms thick.

[0010] A sacrificial metal layer 169 may be formed over the dielectric layer 170. The sacrificial metal layer 169 may be any metal that is capable of withstanding high temperatures (greater than 450° C.) without reaction with overlying materials. As one example, the sacrificial metal layer 169 may be formed of titanium nitride. In one embodiment, the layer 169 may be formed by sputtering. In another embodiment, the layer 169 may be formed by atomic layer deposition.

[0011] After high-k gate dielectric layer 170 and sacrificial metal layer 169 are formed on substrate 100, sacrificial layer 171 is formed on high-k gate dielectric layer 170 as shown in FIG. 1B. In this embodiment, hard mask layer 172 is then formed on sacrificial layer 171, generating the FIG. 1B structure. Sacrificial layer 171 may comprise polysilicon, silicon nitride, silicon germanium, or germanium and may be deposited on sacrificial metal layer 169 using a conventional deposition process. Sacrificial layer 171 may be, for example, between about 100 and about 2,000 Angstroms thick, and, in one embodiment, between about 500 and about 1,600 Angstroms thick. In another embodiment, sacrificial layer 171 may be formed on a dummy gate dielectric, which is later replaced at the time of gate replacement.

[0012] Hard mask layer 172 may comprise silicon nitride between about 100 and about 1000 Angstroms thick, for example, and between about 200 and about 350 Angstroms thick in one embodiment. Hard mask layer 172 may be formed on sacrificial layer 171.

[0013] Sacrificial layer 171 and hard mask layer 172 are then patterned to form patterned hard mask layers 130, 131, and patterned sacrificial layers 104, 106, and 169—as FIG. 1C illustrates. Conventional wet or dry etch processes may

be used to remove unprotected parts of hard mask layer 172, sacrificial metal layer 169 and sacrificial layer 171. In this embodiment, after those layers have been etched, exposed part 174 of high-k gate dielectric layer 170 is removed.

[0014] Although exposed part 174 of high-k gate dielectric layer 170 may be removed using dry or wet etch techniques, it may be difficult to etch that layer using such processes without adversely affecting adjacent structures. It may be difficult to etch high-k gate dielectric layer 170 selectively to the underlying substrate using a dry etch process, and wet etch techniques may etch high-k gate dielectric layer 170 isotropically—undercutting overlying sacrificial layers 104, 106 in an undesirable fashion.

[0015] To reduce the lateral removal of high-k gate dielectric layer 170, as exposed part 174 of that layer is etched, exposed part 174 of high-k gate dielectric layer 170 may be modified to facilitate its removal selectively to covered part 175 of that layer. Exposed part 174 may be modified by adding impurities to that part of high-k gate dielectric layer 170 after sacrificial layer 171 has been etched. A plasma enhanced chemical vapor deposition (“PECVD”) process may be used to add impurities to exposed part 174 of high-k gate dielectric layer 170. In such a PECVD process, a halogen or halide gas (or a combination of such gases) may be fed into a reactor prior to striking a plasma. The reactor should be operated under the appropriate conditions (e.g., temperature, pressure, radio frequency, and power) for a sufficient time to modify exposed part 174 to ensure that it may be removed selectively to other materials. In one embodiment, a low power PECVD process, e.g., one taking place at less than about 200 Watts, is used.

[0016] In one embodiment, hydrogen bromide (“HBr”) and chlorine (“Cl₂”) gases are fed into the reactor at appropriate flow rates to ensure that a plasma generated from those gases will modify exposed part 174 in the desired manner. Between about 50 and about 100 Watts wafer bias (for example, about 100 Watts) may be applied for a sufficient time to complete the desired transformation of exposed part 174. Plasma exposure lasting less than about one minute, and perhaps as short as 5 seconds, may be adequate to cause that conversion.

[0017] After exposed part 174 has been modified, it may be removed. The presence of the added impurities enables that exposed part to be etched selectively to covered part 175 to generate the FIG. 1D structure. In one embodiment, exposed part 174 is removed by exposing it to a relatively strong acid, e.g., a halide based acid (such as hydrobromic or hydrochloric acid) or phosphoric acid. When a halide based acid is used, the acid preferably contains between about 0.5% and about 10% HBr or HCl by volume—and more preferably about 5% by volume. An etch process that uses such an acid may take place at or near room temperature, and last for between about 5 and about 30 minutes although a longer exposure may be used if desired. When phosphoric acid is used, the acid may contain between about 75% and about 95% H₃PO₄ by volume. An etch process that uses such an acid may, for example, take place at between about 140° C. and about 180° C., and, in one embodiment, at about 160° C. When such an acid is used, the exposure step may last between about 30 seconds and about 5 minutes—and for about one minute for a 20 Angstrom thick film.

[0018] FIG. 1D represents an intermediate structure that may be formed when making a complementary metal oxide semiconductor (“CMOS”). That structure includes first part 101 and second part 102 of substrate 100 shown in FIG. 1E. Isolation region 103 separates first part 101 from second part 102. Isolation region 103 may comprise silicon dioxide, or other materials that may separate the transistor’s active regions. First sacrificial layer 104 is formed on first high-k gate dielectric layer 105, and second sacrificial layer 106 is formed on second high-k gate dielectric layer 107. Hard masks 130, 131 are formed on sacrificial layers 104, 106.

[0019] After forming the FIG. 1D structure, spacers may be formed on opposite sides of sacrificial layers 104, 106. When those spacers comprise silicon nitride, they may be formed in the following way. First, a silicon nitride layer of substantially uniform thickness, for example, less than about 1000 Angstroms thick—is deposited over the entire structure, producing the structure shown in FIG. 1E. Conventional deposition processes may be used to generate that structure.

[0020] In one embodiment, silicon nitride layer 134 is deposited directly on substrate 100 and opposite sides of sacrificial layers 104, 106—without first forming a buffer oxide layer on substrate 100 and layers 104, 106. In alternative embodiments, however, such a buffer oxide layer may be formed prior to forming layer 134. Similarly, although not shown in FIG. 1E, a second oxide may be formed on layer 134 prior to etching that layer. If used, such an oxide may enable the subsequent silicon nitride etch step to generate an L-shaped spacer.

[0021] Silicon nitride layer 134 may be etched using a conventional process for anisotropically etching silicon nitride to create the FIG. 1F structure. As a result of that etch step, sacrificial layer 104 is bracketed by a pair of sidewall spacers 108, 109, and sacrificial layer 106 is bracketed by a pair of sidewall spacers 110, 111.

[0022] The structure of FIG. 1F may then be covered with a nitride etch stop layer 180 to form the structure of FIG. 1G. The layer 180 may be formed in the same way as the layer 134.

[0023] As is typically done, it may be desirable to perform multiple masking and ion implantation steps (FIG. 1H) to create lightly implanted regions 135a-138a near layers 104, 106 (that will ultimately serve as tip regions for the device’s source and drain regions), prior to forming spacers 108, 109, 110, 111 on sacrificial layers 104, 106. Also as is typically done, the source and drain regions 135-138 may be formed, after forming spacers 108, 109, 110, 111, by implanting ions into parts 101 and 102 of substrate 100, followed by applying an appropriate anneal step.

[0024] An ion implantation and anneal sequence used to form n-type source and drain regions within part 101 of substrate 100 may dope sacrificial layer 104 n-type at the same time. Similarly, an ion implantation and anneal sequence used to form p-type source and drain regions within part 102 of substrate 100 may dope sacrificial layer 106 p-type. When doping sacrificial layer 106 with boron, that layer should include that element at a sufficient concentration to ensure that a subsequent wet etch process, for removing n-type sacrificial layer 104, will not remove a significant amount of p-type sacrificial layer 106.

[0025] The anneal will activate the dopants that were previously introduced into the source and drain regions and tip regions and into sacrificial layers **104**, **106**. In a preferred embodiment, a rapid thermal anneal is applied that takes place at a temperature that exceeds about 1,000° C.—and, optimally, that takes place at 1,080° C. In addition to activating the dopants, such an anneal may modify the molecular structure of high-k gate dielectric layers **105**, **107** to create gate dielectric layers that may demonstrate improved performance.

[0026] Because of the imposition of the sacrificial metal layer **169**, better performing dielectric layers **170** may result from these high temperature steps without significant reaction between the high dielectric constant dielectric layer **170** and the sacrificial layer **171**.

[0027] After forming spacers **108**, **109**, **110**, **111**, and layer **180**, dielectric layer **112** may be deposited over the device, generating the **FIG. 1H** structure. Dielectric layer **112** may comprise silicon dioxide, or a low-k material. Dielectric layer **112** may be doped with phosphorus, boron, or other elements, and may be formed using a high density plasma deposition process. By this stage of the process, source and drain regions **135**, **136**, **137**, **138**, which are capped by silicided regions **139**, **140**, **141**, **142**, have already been formed. Those source and drain regions may be formed by implanting ions into the substrate, then activating them. Alternatively, an epitaxial growth process may be used to form the source and drain regions, as will be apparent to those skilled in the art.

[0028] Dielectric layer **112** is removed from hard masks **130**, **131**, which are, in turn, removed from patterned sacrificial layers **104**, **106**, producing the **FIG. 1I** structure. A conventional chemical mechanical polishing (“CMP”) operation may be applied to remove that part of dielectric layer **112** and hard masks **130**, **131**. Hard masks **130**, **131** may be removed to expose patterned sacrificial layers **104**, **106**. Hard masks **130**, **131** may be polished from the surface of layers **104**, **106**, when dielectric layer **112** is polished—as they will have served their purpose by that stage in the process.

[0029] After forming the **FIG. 1I** structure, sacrificial layer **104** is removed to generate trench **113** that is positioned between sidewall spacers **108**, **109**—producing the structure shown in **FIG. 1J**.

[0030] In one embodiment, a wet etch process that is selective for layer **104** over sacrificial layer **106** is applied to remove layers **104** and **169** without removing significant portions of layer **106**.

[0031] When sacrificial layer **104** is doped n-type, and sacrificial layer **106** is doped p-type (e.g., with boron), such a wet etch process may comprise exposing sacrificial layer **104** to an aqueous solution that comprises a source of hydroxide for a sufficient time at a sufficient temperature to remove substantially all of layer **104**. That source of hydroxide may comprise between about 2 and about 30 percent ammonium hydroxide or a tetraalkyl ammonium hydroxide, e.g., tetramethyl ammonium hydroxide (“TMAH”), by volume in deionized water.

[0032] Any remaining sacrificial layer **104** may be selectively removed by exposing it to a solution, which is maintained at a temperature between about 15° C. and about

90° C. (for example, below about 40° C.), that comprises between about 2 and about 30 percent ammonium hydroxide by volume in deionized water. During that exposure step, which preferably lasts at least one minute, it may be desirable to apply sonic energy at a frequency of between about 10 kHz and about 2,000 kHz, while dissipating at between about 1 and about 10 Watts/cm².

[0033] In one embodiment, sacrificial layer **104**, with a thickness of about 1,350 Angstroms, may be selectively removed by exposing it at about 25° C. for about 30 minutes to a solution that comprises about 15 percent ammonium hydroxide by volume in deionized water, while applying sonic energy at about 1,000 kHz—dissipating at about 5 Watts/cm². Such an etch process should remove substantially all of an n-type sacrificial layer **104** without removing a meaningful amount of a p-type sacrificial layer **106**.

[0034] As an alternative, sacrificial layer **104** may be selectively removed by exposing it for at least one minute to a solution, which is maintained at a temperature between about 60° C. and about 90° C., that comprises between about 20 and about 30 percent TMAH by volume in deionized water, while applying sonic energy. Removing sacrificial layer **104**, with a thickness of about 1,350 Angstroms, by exposing it at about 80° C. for about 2 minutes to a solution that comprises about 25 percent TMAH by volume in deionized water, while applying sonic energy at about 1,000 kHz—dissipating at about 5 Watts/cm²—may remove substantially all of layer **104** without removing a significant amount of layer **106**. First high-k gate dielectric layer **105** should be sufficiently thick to prevent the etchant that is applied to remove sacrificial layer **104** from reaching the channel region that is located beneath first high-k gate dielectric layer **105**.

[0035] The sacrificial metal layer **169** may also be removed by selective etching. In some embodiments, the layer **169** may not be removed. In some embodiments, the dielectric layer **105** may be removed before forming the replacement metal gate. In such case, a metal oxide gate dielectric may be formed before forming the replacement gate.

[0036] In the illustrated embodiment, n-type metal layer **115** is formed directly on layer **105** to fill trench **113** and to generate the **FIG. 1K** structure. N-type metal layer **115** may comprise any n-type conductive material from which a metal NMOS gate electrode may be derived. N-type metal layer **115** preferably has thermal stability characteristics that render it suitable for making a metal NMOS gate electrode for a semiconductor device.

[0037] Materials that may be used to form n-type metal layer **115** include: hafnium, zirconium, titanium, tantalum, aluminum, and their alloys, e.g., metal carbides that include these elements, i.e., hafnium carbide, zirconium carbide, titanium carbide, tantalum carbide, and aluminum carbide. N-type metal layer **115** may be formed on first high-k gate dielectric layer **105** using well known PVD or CVD processes, e.g., conventional sputter or atomic layer CVD processes. As shown in **FIG. 1L**, n-type metal layer **115** is removed except where it fills trench **113**. Layer **115** may be removed from other portions of the device via a wet or dry etch process, or an appropriate CMP operation. Dielectric **112** may serve as an etch or polish stop, when layer **115** is removed from its surface.

[0038] N-type metal layer **115** may serve as a metal NMOS gate electrode that has a workfunction that is between about 3.9 eV and about 4.2 eV, and that is between about 100 Angstroms and about 2,000 Angstroms thick and, in one embodiment, may particularly be between about 500 Angstroms and about 1,600 Angstroms thick. Although **FIGS. 1J and 1K** represent structures in which n-type metal layer **115** fills all of trench **113**, in alternative embodiments, n-type metal layer **115** may fill only part of trench **113**, with the remainder of the trench being filled with a material that may be easily polished, e.g., tungsten, aluminum, titanium, or titanium nitride. Using a higher conductivity fill metal in place of the workfunction metal may improve the overall conductivity of the gate stack. In such an alternative embodiment, n-type metal layer **115**, which serves as the workfunction metal, may be between about 50 and about 1,000 Angstroms thick and, for example, at least about 100 Angstroms thick.

[0039] In embodiments in which trench **113** includes both a workfunction metal and a trench fill metal, the resulting metal NMOS gate electrode may be considered to comprise the combination of both the workfunction metal and the trench fill metal. If a trench fill metal is deposited on a workfunction metal, the trench fill metal may cover the entire device when deposited, forming a structure like the **FIG. 1K** structure. That trench fill metal must then be polished back so that it fills only the trench, generating a structure like the **FIG. 1L** structure.

[0040] In the illustrated embodiment, after forming n-type metal layer **115** within trench **113**, sacrificial layer **106** is removed to generate trench **150** that is positioned between sidewall spacers **110, 111**—producing the structure shown in **FIG. 1M**. In a preferred embodiment, layer **106** is exposed to a solution that comprises between about 20 and about 30 percent TMAH by volume in deionized water for a sufficient time at a sufficient temperature (e.g., between about 60° C. and about 90° C.), while applying sonic energy, to remove all of layer **106** without removing significant portions of n-type metal layer **115**.

[0041] Alternatively, a dry etch process may be applied to selectively remove layer **106**. When sacrificial layer **106** is doped p-type (e.g., with boron), such a dry etch process may comprise exposing sacrificial layer **106** to a plasma derived from sulfur hexafluoride (“SF₆”), hydrogen bromide (“HBr”), hydrogen iodide (“HI”), chlorine, argon, and/or helium. Such a selective dry etch process may take place in a parallel plate reactor or in an electron cyclotron resonance etcher.

[0042] After removing sacrificial layer **106**, it may be desirable to clean second high-k gate dielectric layer **107**, e.g., by exposing that layer to the hydrogen peroxide based solution described above. Optionally, as mentioned above, a capping layer (which may be oxidized after it is deposited) may be formed on second high-k gate dielectric layer **107** prior to filling trench **150** with a p-type metal. In this embodiment, however, p-type metal layer **116** is formed directly on layer **107** to fill trench **150** and to generate the **FIG. 1N** structure. P-type metal layer **116** may comprise any p-type conductive material from which a metal PMOS gate electrode may be derived. P-type metal layer **116** preferably has thermal stability characteristics that render it suitable for making a metal PMOS gate electrode for a semiconductor device.

[0043] Materials that may be used to form p-type metal layer **116** include: ruthenium, palladium, platinum, cobalt, nickel, and conductive metal oxides, e.g., ruthenium oxide. P-type metal layer **116** may be formed on second high-k gate dielectric layer **107** using well known PVD or CVD processes, e.g., conventional sputter or atomic layer CVD processes. As shown in **FIG. 10**, p-type metal layer **116** is removed except where it fills trench **150**. Layer **116** may be removed from other portions of the device via a wet or dry etch process, or an appropriate CMP operation, with dielectric **112** serving as an etch or polish stop.

[0044] P-type metal layer **116** may serve as a metal PMOS gate electrode with a workfunction that is between about 4.9 eV and about 5.2 eV, and that is between about 100 Angstroms and about 2,000 Angstroms thick, and more preferably is between about 500 Angstroms and about 1,600 Angstroms thick. Although **FIGS. 1N and 1O** represent structures in which p-type metal layer **116** fills all of trench **150**, in alternative embodiments, p-type metal layer **116** may fill only part of trench **150**. As with the metal NMOS gate electrode, the remainder of the trench may be filled with a material that may be easily polished, e.g., tungsten, aluminum, titanium, or titanium nitride. In such an alternative embodiment, p-type metal layer **116**, which serves as the workfunction metal, may be between about 50 and about 1,000 Angstroms thick. Like the metal NMOS gate electrode, in embodiments in which trench **150** includes a workfunction metal and a trench fill metal, the resulting metal PMOS gate electrode may be considered to comprise the combination of both the workfunction metal and the trench fill metal.

[0045] Next, the dielectric layer **112** may be removed to form the structure shown in **FIG. 1P**. A new nitride etch stop layer **181** may then be deposited as shown in **FIG. 1Q**. The layer **181** may, in one embodiment, be identical to the layer **180**. Then, the dielectric layer **214** may be deposited as shown in **FIG. 1R** to form an interlayer dielectric. The layer **214** may be formed of the same material and in the same fashion as the layer **112**.

[0046] Because a portion of the nitride etch stop layer **180** was removed in the course of removing the layers **104** and **106**, the benefits that such a layer could have provided in reducing strain are eliminated. Therefore, by re-adding a layer **181** and a layer **214**, the benefits of a strain reducing layer and an etch stop layer may be resurrected. In some embodiments, any dielectric **214** may be utilized. For example, the dielectric **214** may be a low-K dielectric layer such as porous or non-porous carbon-doped oxide having a dielectric constant less than about 5, for example about 3.2.

[0047] While the present invention has been described with respect to a limited number of embodiments, those skilled in the art will appreciate numerous modifications and variations therefrom. It is intended that the appended claims cover all such modifications and variations as fall within the true spirit and scope of this present invention.

What is claimed is:

1. A method comprising:
 - forming a sacrificial gate structure;
 - removing said sacrificial gate structure;

replacing said sacrificial gate structure with a metal gate electrode; and

covering said metal gate electrode with a nitride layer.

2. The method of claim 1 including covering said nitride layer with an interlayer dielectric.

3. The method of claim 2 including covering said nitride layer with an interlayer dielectric having a dielectric constant less than five.

4. The method of claim 1 including forming a pair of sacrificial gate structures and replacing said sacrificial gate structures with metal gate electrodes adapted to form NMOS and PMOS transistors.

5. The method of claim 1 wherein forming a sacrificial gate structure includes forming a polysilicon gate structure with sidewall spacers.

6. A method comprising:

forming a pair of sacrificial gate structures;

removing said sacrificial gate structures;

replacing said sacrificial gate structures with metal gate electrodes; and

covering said metal gate electrodes with a nitride layer.

7. The method of claim 6 including covering said nitride layer with an interlayer dielectric.

8. The method of claim 6 including forming a pair of sacrificial gate structures and replacing said sacrificial gate structures with metal gate electrodes adapted to form NMOS and PMOS transistors.

9. The method of claim 6 wherein forming a sacrificial gate structure includes forming a polysilicon gate structure with sidewall spacers.

10. A semiconductor structure comprising:

a substrate;

a metal gate electrode formed over said substrate;

a nitride layer over said metal gate electrode; and

an interlayer dielectric layer over said nitride layer.

11. The structure of claim 10 wherein said interlayer dielectric has a dielectric constant less than five.

12. The structure of claim 10 wherein said structure includes a pair of metal gate electrodes, one for an NMOS transistor and one for a PMOS transistor.

13. The structure of claim 10 wherein said nitride layer is in direct contact with said gate electrode.

14. The structure of claim 10 wherein said interlayer dielectric fills the region between metal gate electrodes.

15. The structure of claim 10 wherein said interlayer dielectric is carbon-doped oxide.

* * * * *