

HE PHY Padding and Packet Extension

Date: 2015-07-10

Authors:

Name	Affiliation	Address	Phone	Email
Hongyuan Zhang	Marvell	5488 Marvell Lane, Santa Clara, CA, 95054	408-222-2500	hongyuan@marvell.com
Yakun Sun				yakunsun@marvell.com
Lei Wang				Leileiw@marvell.com
Liwen Chu				liwenchu@marvell.com
Jinjing Jiang				jinjing@marvell.com
Yan Zhang				yzhang@marvell.com
Rui Cao				ruicao@marvell.com
Bo Yu				jiehuang@marvell.com
Sudhir Srinivasa				sudhirs@marvell.com
Saga Tamhane				sagar@marvell.com
Mao Yu				my@marvel.com
Edward Au				edwardau@marvell.com
Hui-Ling Lou				hlou@marvell.com

Wilus Institute of Standards and Technology Inc.,
Ex. 2022, IPR2025-01069
Page 1 of 38

Authors (continued)

Name	Affiliation	Address	Phone	Email
Albert Van Zelst	Qualcomm	Straatweg 66-S Breukelen, 3621 BR Netherlands		allert@qti.qualcomm.com
Alfred Asterjadhi		5775 Morehouse Dr. San Diego, CA, USA		aasterja@qti.qualcomm.com
Arjun Bharadwaj		5775 Morehouse Dr. San Diego, CA, USA		arjunb@qti.qualcomm.com
Bin Tian		5775 Morehouse Dr. San Diego, CA, USA		btian@qti.qualcomm.com
Carlos Aldana		1700 Technology Drive San Jose, CA 95110, USA		caldana@qca.qualcomm.com
George Cherian		5775 Morehouse Dr. San Diego, CA, USA		gcherian@qti.qualcomm.com
Gwendolyn Barriac		5775 Morehouse Dr. San Diego, CA, USA		gbarriac@qti.qualcomm.com
Hemanth Sampath		5775 Morehouse Dr. San Diego, CA, USA		hsampath@qti.qualcomm.com
Menzo Wentink		Straatweg 66-S Breukelen, 3621 BR Netherlands		mwentink@qti.qualcomm.com
Richard Van Nee		Straatweg 66-S Breukelen, 3621 BR Netherlands		rvannee@qti.qualcomm.com
Rolf De Vegt		1700 Technology Drive San Jose, CA 95110, USA		rolfv@qca.qualcomm.com
Sameer Vermani		5775 Morehouse Dr. San Diego, CA, USA		svverman@qti.qualcomm.com
Simone Merlin		5775 Morehouse Dr. San Diego, CA, USA		smerlin@qti.qualcomm.com
Tevfik Yucek		1700 Technology Drive San Jose, CA 95110, USA		tyucek@qca.qualcomm.com
VK Jones		1700 Technology Drive San Jose, CA 95110, USA	Wilus Institute of Standards & Technology, Inc.	vkjones@qualcomm.com
Youhan Kim	1700 Technology Drive San Jose, CA 95110, USA		youhank@qca.qualcomm.com	

Authors (continued)

Name	Affiliation	Address	Phone	Email
Robert Stacey	Intel	2111 NE 25th Ave, Hillsboro OR 97124, USA	+1-503-724-893	robert.stacey@intel.com
Eldad Perahia				eldad.perahia@intel.com
Shahrnaz Azizi				shahrnaz.azizi@intel.com
Po-Kai Huang				po-kai.huang@intel.com
Qinghua Li				qinghua.li@intel.com
Xiaogang Chen				xiaogang.c.chen@intel.com
Chitto Ghosh				chittabrata.ghosh@intel.com
Laurent cariou				laurent.cariou@intel.com
Rongzhen Yang				rongzhen.yang@intel.com
Ron Porat	Broadcom			rporat@broadcom.com
Matthew Fischer				mfischer@broadcom.com
Sriram Venkateswaran				
Andrew Blanksby				
Matthias Korb				
Tu Nguyen				
Vinko Erceg				

Wilus Institute of Standards and Technology Inc.,

Ex. 2022, IPR2025-01069

Page 3 of 38

Authors (continued)

Name	Affiliation	Address	Phone	Email
James Yee	Mediatek	No. 1 Dusing 1 st Road, Hsinchu, Taiwan	+886-3-567-0766	james.yee@mediatek.com
Alan Jauh				alan.jauh@mediatek.com
Chingwa Hu				chingwa.yu@mediatek.com
Frank Hsu				frank.hsu@mediatek.com
Thomas Pare	Mediatek USA	2860 Junction Ave, San Jose, CA 95134, USA	+1-408-526-1899	thomas.pare@mediatek.com
ChaoChun Wang				chaochun.wang@mediatek.com
James Wang				james.wang@mediatek.com
Jianhan Liu				Jianhan.Liu@mediatek.com
Tianyu Wu				tianyu.wu@mediatek.com
Russell Huang				russell.huang@mediatek.com
Joonsuk Kim	Apple			joonsuk@apple.com
Aon Mujtaba				mujtaba@apple.com
Guoqing Li				guoqing_li@apple.com
Eric Wong				ericwong@apple.com
Chris Hartman				chartman@apple.com

Authors (continued)

Name	Affiliation	Address	Phone	Email
Phillip Barber	Huawei	The Lone Star State, TX		pbarber@broadbandmobiletech.com
Peter Loc				peterloc@iwirelesstech.com
Le Liu		F1-17, Huawei Base, Bantian, Shenzhen	+86-18601656691	liule@huawei.com
Jun Luo		5B-N8, No.2222 Xinjinqiao Road, Pudong, Shanghai		jun.l@huawei.com
Yi Luo		F1-17, Huawei Base, Bantian, Shenzhen	+86-18665891036	Roy.luoyi@huawei.com
Yingpei Lin		5B-N8, No.2222 Xinjinqiao Road, Pudong, Shanghai		linyipingpei@huawei.com
Jiyong Pang		5B-N8, No.2222 Xinjinqiao Road, Pudong, Shanghai		pangjiyong@huawei.com
Zhigang Rong		10180 Telesis Court, Suite 365, San Diego, CA 92121 NA		zhigang.rong@huawei.com
Rob Sun		303 Terry Fox, Suite 400 Kanata, Ottawa, Canada		Rob.Sun@huawei.com
David X. Yang		F1-17, Huawei Base, Bantian, Shenzhen		david.yangxun@huawei.com
Yunsong Yang		10180 Telesis Court, Suite 365, San Diego, CA 92121 NA		yangyunsong@huawei.com
Zhou Lan		F1-17, Huawei Base, Bantian, SHenzhen	+86-18565826350	LanzhouL@huawei.com
Junghoon Suh		303 Terry Fox, Suite 400 Kanata, Ottawa, Canada		Junghoon.Suh@huawei.com
Jiayin Zhang		5B-N8, No.2222 Xinjinqiao Road, Pudong, Shanghai	+86-18601656691	zhangjiayin@huawei.com

Authors (continued)

Name	Affiliation	Address	Phone	Email
Hyeyoung Choi	LG Electronics	19, Yangjae-daero 11gil, Seocho-gu, Seoul 137- 130, Korea		hy0117.choi@lge.com
Kiseon Ryu				kiseon.ryu@lge.com
Jinyoung Chun				jiny.chun@lge.com
Jinsoo Choi				js.choi@lge.com
Jeongki Kim				jeongki.kim@lge.com
Giwon Park				giwon.park@lge.com
Dongguk Lim				dongguk.lim@lge.com
Suhwook Kim				suhwook.kim@lge.com
Eunsung Park				esung.park@lge.com
HanGyu Cho				hg.cho@lge.com
Thomas Derham	Orange			thomas.derham@orange.com
Bo Sun	ZTE	#9 Wuxingduan, Xifeng Rd., Xi'an, China		sun.bo1@zte.com.cn
Kaiying Lv				lv.kaiying@zte.com.cn
Yonggang Fang				yfang@ztttx.com
Ke Yao				yao.ke5@zte.com.cn
Weimin Xing				xing.weimin@zte.com.cn
Brian Hart	Cisco Systems	170 W Tasman Dr, San Jose, CA 95134		brianh@cisco.com
Pooya Monajemi				pmonajem@cisco.com

Wilus Institute of Standards and Technology Inc.,
Ex. 2022, IPR2025-01069
Page 6 of 38

Authors (continued)

Name	Affiliation	Address	Phone	Email
Fei Tong	Samsung	Innovation Park, Cambridge CB4 0DS (U.K.)	+44 1223 434633	f.tong@samsung.com
Hyunjeong Kang		Maetan 3-dong; Yongtong-Gu Suwon; South Korea	+82-31-279-9028	hyunjeong.kang@samsung.com
Kaushik Josiam		1301, E. Lookout Dr, Richardson TX 75070	(972) 761 7437	k.josiam@samsung.com
Mark Rison		Innovation Park, Cambridge CB4 0DS (U.K.)	+44 1223 434600	m.rison@samsung.com
Rakesh Taori		1301, E. Lookout Dr, Richardson TX 75070	(972) 761 7470	rakesh.taori@samsung.com
Sanghyun Chang		Maetan 3-dong; Yongtong-Gu Suwon; South Korea	+82-10-8864-1751	s29.chang@samsung.com
Yasushi Takatori		NTT	1-1 Hikari-no-oka, Yokosuka, Kanagawa 239-0847 Japan	
Yasuhiko Inoue				inoue.yasuhiko@lab.ntt.co.jp
Yusuke Asai				asai.yusuke@lab.ntt.co.jp
Koichi Ishihara				ishihara.koichi@lab.ntt.co.jp
Akira Kishida				kishida.akira@lab.ntt.co.jp
Akira Yamada	NTT DOCOMO			3-6, Hikinooka, Yokosuka- shi, Kanagawa, 239-8536, Japan
Fujio Watanabe		3240 Hillview Ave, Palo Alto, CA 94304		watanabe@docomoinnovations.com
Haralabos Papadopoulos				hpapadopoulos@docomoinnovations.com

Overview

- HE PHY adopts 4x Numerology [1], mainly for: facilitate OFDMA design, facilitate outdoor channel support, increase PHY efficiency.
- **Area Penalty**: ~4x NDBPS compared with 1lac with same BW.
 - Lead to big area or implementation complexity concern, if SIFS time duration is unchanged.
 - ~4x processing speed is required for the last OFDM symbol, for **Rx → Tx turn-around within SIFS (FFT, MIMO-EQ, Decoding, MAC, Tx)**.
 - Especially at peak data rates (256AM).
- **Overhead Penalty**: on the other hand, increasing SIFS or equivalently adding long packet extension (PE) may offset the throughput gain of 4x numerology.
- **Tradeoffs** between Area and Overhead:
 - Challenging to optimize both at the same time.
 - Different options give different levels of tradeoffs, with different solution for either reducing area/complexity or reducing overhead.

Proposed HE Padding and Packet Extension

- The last m_{STBC} symbol(s) have 4x duration like other data symbols (12.8us+GI).
- Apply a **two-step padding method** in the last m_{STBC} OFDM symbol(s), i.e.: “Pre-FEC” padding, and “post-FEC” padding.
 - Four possible pre-FEC padding segment boundaries (“ a –factor”) are defined in the last OFDM symbol(s).
 - Based on number of excess info bits in the last symbol(s), pre-FEC pad (**the same MAC/PHY padding as in 11ac**) toward the nearest boundaries in the last symbol(s).
 - For LDPC, if “LDPC extra symbol” is needed after puncturing, increment one segment ($a = a_{init}+1$), instead of one long symbol.
 - After FEC, insert post-FEC padding bits (no need to decode) to fill up the symbol(s).
 - Post FEC padding is adding by PHY and does not need to be decoded by the receiver
- A Packet Extension (PE) field is applied at the end of PPDU, and its duration is a function of the followings:
 1. The pre-FEC padding boundaries in the last m_{STBC} OFDM symbols (“ a – factor”).
 2. Receiving STA’s capability on its required PE duration, for the current {BW, Nss, MCS} combination.

Bit Stream Illustration

Bit stream of the last OFDM symbol (non-STBC)

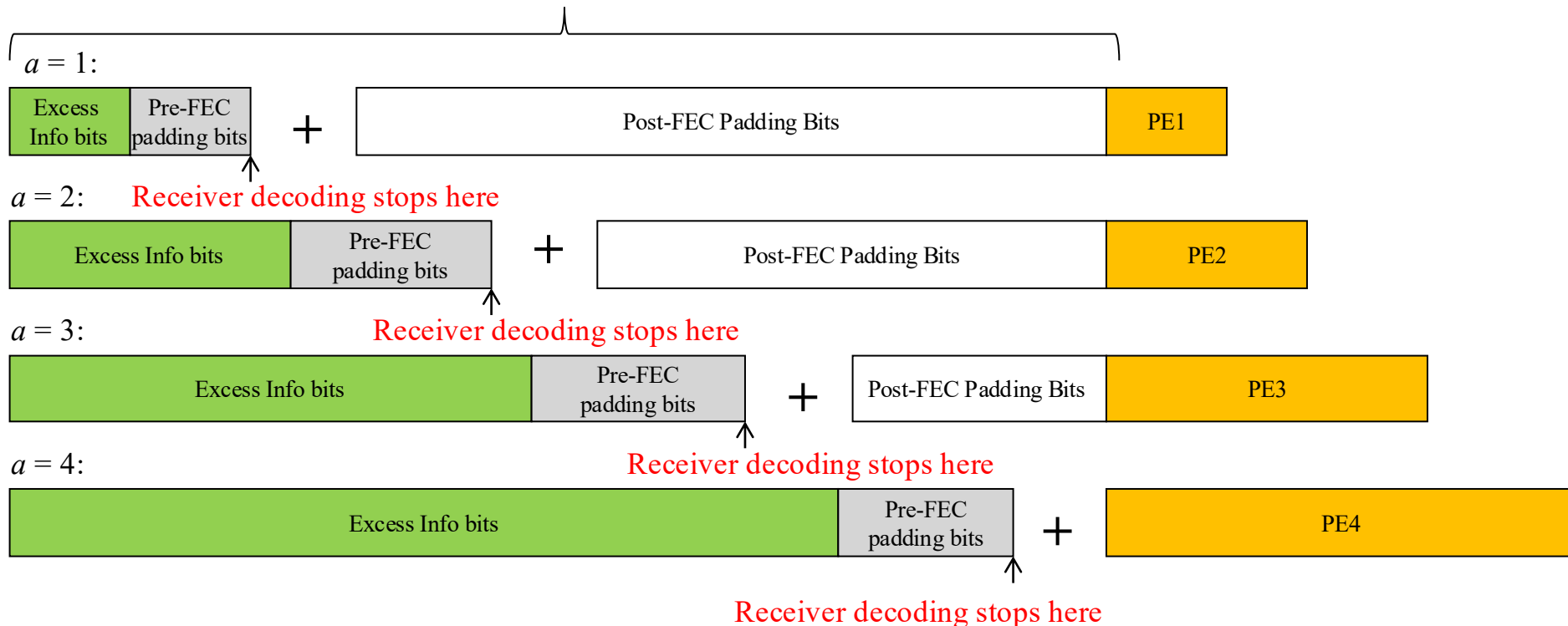

Refer to Appendix for the Math

Wilus Institute of Standards and Technology Inc.,
Ex. 2022, IPR2025-01069
Page 10 of 38

LDPC Encoding Illustration

- Use $a=1$ and LDPC case as an example.

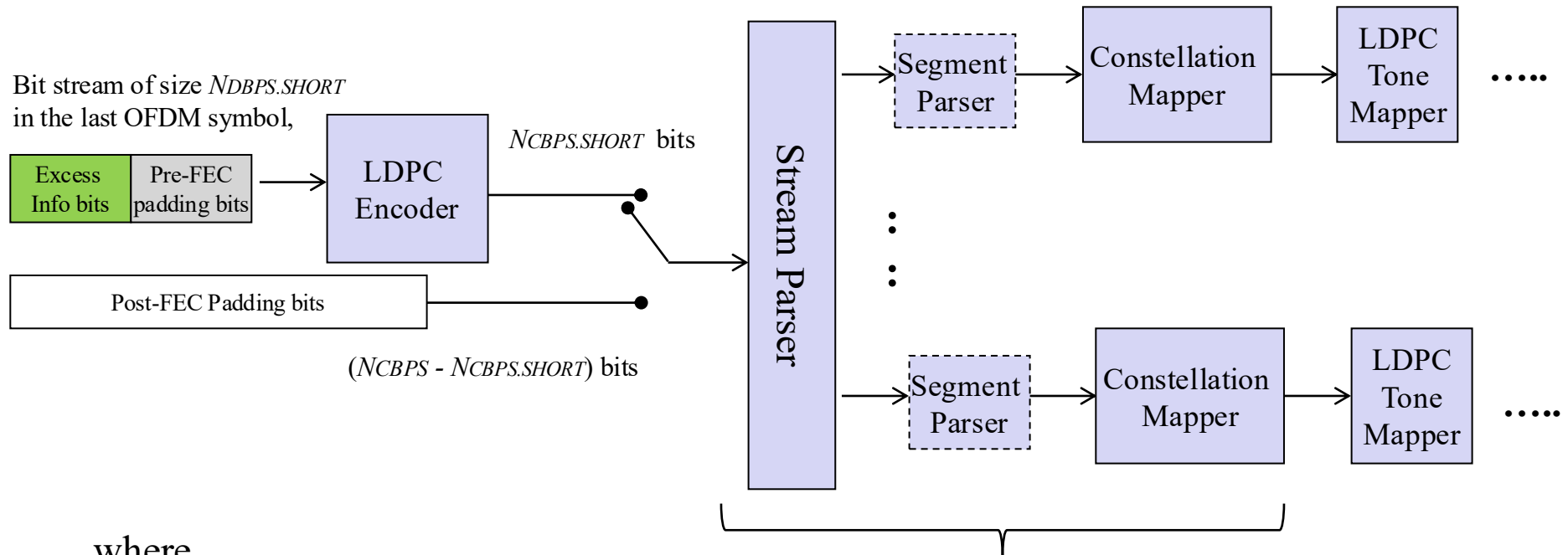

where

$$N_{CBPS,short} = N_{SD,short} \cdot N_{SS} \cdot N_{BPSCS}$$

$$N_{DBPS,short} = N_{CBPS,short} \cdot R$$

Stream/Segment Parsers are all FIFO on the bits stream, therefore the info and pre-FEC padding bits are contained in the first $N_{SD.SHORT}$ tones before LDPC tone mapper

Processing Delay

- For LDPC:
 - 4x FFT → 4x Tone Demapper → **Only take the first $N_{SD.SHORT}$ tones** → FD processing (MIMO Equalizer, LDPC Decoder) → MAC processing.
 - Post-FEC padding bits are not processed.
- For BCC:
 - Almost all tones need to be processed due to interleaver.
 - However, we propose to disallow BCC in 80MHz and 160MHz. See [2] for more details.

Packet Extension Field

- PE durations for different pre-FEC padding boundaries (*a-factor* values).
 - Based on decoding capability of the device.
 - An Example where max PE duration is 16us:
 - TPE1 = 4us, or $\sim 1/4$ long symbol ($a=1$)
 - TPE2 = 8us, or $\sim 1/2$ long symbol ($a=2$)
 - TPE3 = 12us, or $\sim 3/4$ long symbol ($a=3$)
 - TPE4 = 16us, or ~ 1 long symbol ($a=4$)
 - TPE values are multiple of 4us, for easier L-LENGTH signaling and legacy spoofing.

$a = 4$:



- A non-zero signal with the same average power as the data should be transmitted in PE field.
 - To avoid legacy receiver's early termination of CCA-Busy status, due to "carrier lost".

Wilus Institute of Standards and Technology Inc.,

Ex. 2022, IPR2025-01069

Page 13 of 38

Packet Extension Field—cont'd

- Each STA may claim its PE Capability for receiving PPDU for different {BW, Nss, MCS} combinations.
 - Defining two constellation thresholds per {BW, Nss} to split MCSs into 3 groups, corresponding to 0us, and two non-zero max PE durations (equivalent to max PE durations of 8us and 16us respectively).
 - To be clear, the 3 categories are:
 - “0us”: $T_{PE} = [0\ 0\ 0\ 0]$ us, for a=1~4 respectively
 - “8us”: $T_{PE} = [0\ 0\ 4\ 8]$ us, for a=1~4 respectively
 - “16us”: $T_{PE} = [4\ 8\ 12\ 16]$ us, for a=1~4 respectively
- When STA indicates 80MHz capability or higher, 0 μ s PE is applied for RU \leq 20MHz
 - No capability indicated for RU \leq 20MHz in this case
 - Otherwise, PE capability is indicated down to TBD RU sizes.

PE Capability—Illustration

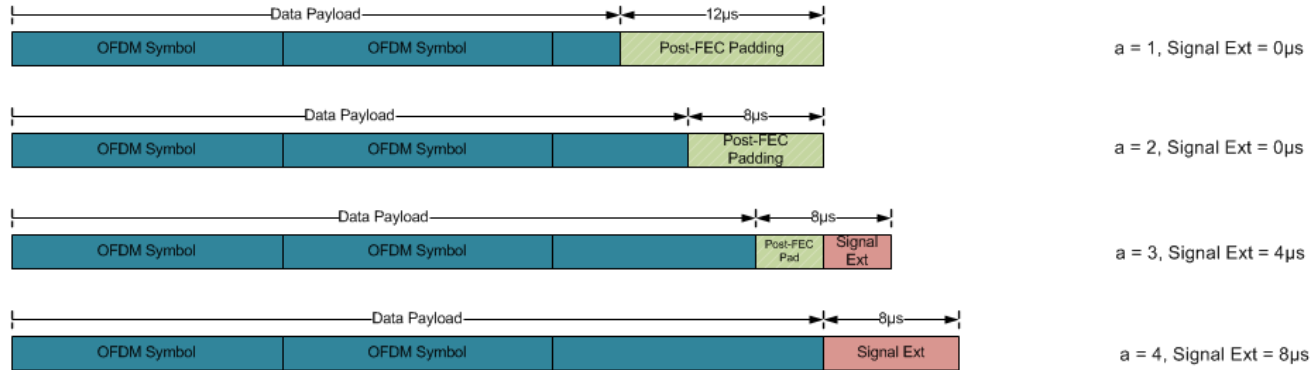

Max PE 8µs mode

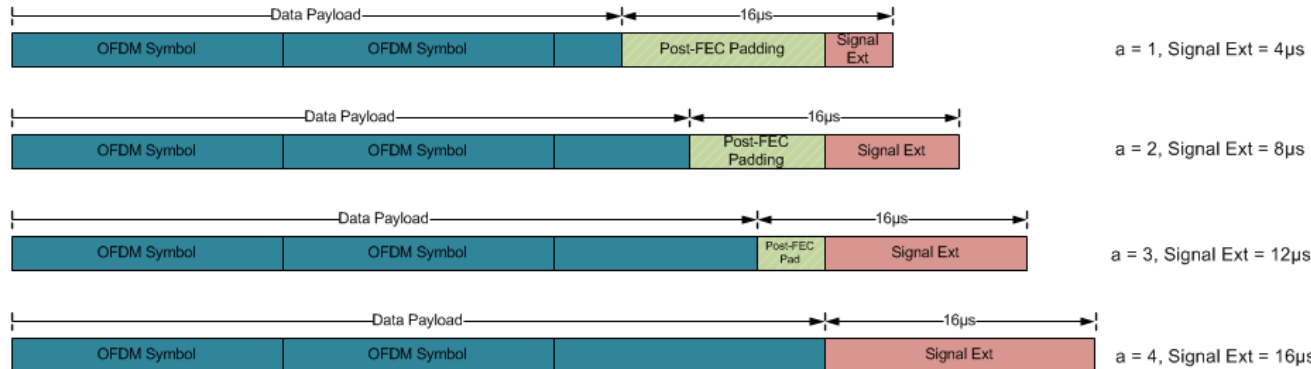

Max PE 16µs mode

Constellation Thresholds for PE Capability (i)

- HE device capability for determining PE duration is based on two constellation thresholds per {NSS, BW}
- If constellation $\geq threshold_{16}$ apply max PE 16 μ s mode, else if constellation $\geq threshold_8$ apply max PE 8 μ s mode, else no packet extension
- The encoding constellation thresholds:

constellation	HE capability encoding
BPSK	000
QPSK	001
16QAM	010
64QAM	011
256QAM	100
1024QAM (TBD)	101
None	111

- Example: max PE 8 μ s for 64QAM, max PE 16 μ s for 256QAM and 1024QAM (TBD)

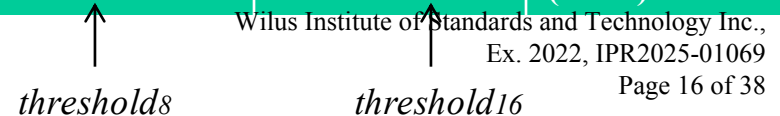
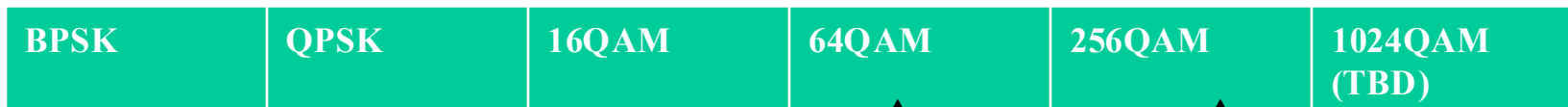

Constellation Thresholds for PE Capability (ii)

- Some special cases are as follows:
 - If no PE is required both $threshold_8$ and $threshold_{16}$ are set to 111
 - If only max PE 8 μ s mode is used, set $threshold_{16}$ to be 111, and $threshold_8$ to be the constellation at which max PE 8 μ s mode starts
 - If only max PE 16 μ s mode is used, set $threshold_{16}$ to be the constellation at which max PE 16 μ s mode starts, and $threshold_8$ to be 111

Padding Parameters to Avoid MCS Exclusion

- If we strictly choose $\frac{1}{4}$ number of tones, for certain BW and MCS, $N_{CBPS,short}$ and $N_{DBPS,short}$ (or $N_{DBPS,short}/N_{ES}$) are not integers.
- The simplest approach to avoid excluding MCS: define a **compatible** $N_{SD,SHORT}$ for the last symbol.
 - Suggested $N_{SD,short}$ for each RU size as shown in the table below:
 - Integer $N_{CBPS,short}$, $N_{DBPS,short}$ and $N_{DBPS,short}/N_{ES}$ for 20MHz and below (≤ 242 -RU)
 - Integer $N_{CPBS,short}$ and $N_{DBPS,short}$ for 40MHz and above (LDPC only).
 - The pre-FEC symbol segments become slightly uneven between $a=1\sim 3$ and $a=4$ for some RU. But the performance difference should be very negligible.
 - Encoding procedure described in Appendix starts by:

$$N_{CBPS,short} = N_{SD,short} \cdot N_{SS} \cdot N_{BPSCS}$$

$$N_{DBPS,short} = N_{CBPS,short} \cdot R$$

RU Size	$N_{SD,Short}$
26	6
52	12
106	24
242	60
484	120
996	240
996x2	492

Wilus Institute of Standards and Technology Inc.,

Ex. 2022, IPR2025-01069

Page 18 of 38

DL-MU Padding Method (1)

- All user's data fields end at the same time in the DL-MU PPDU.
- All users share the same PE duration.
- All users share a common *a-factor* across all users, based on the user with the longest span.
 - Clean design, simple signaling, simple padding as in 11ac.
 - Minimize SIG field overhead, no per-user fields needed.
 - No per-user *a-factor* field.
 - As in 11ac DLMU, there is only 1 common bit needed for all users indicating “LDPC extra symbol”, even if some users are doing BCC!
- Based on *a-factor* value and each user's PE capabilities, AP computes the PE duration for each user $T_{PE,u}$, and the PE duration of the whole DL-MU PPDU is $T_{PE} = \max_{u=0,\dots,N_u-1} (T_{PE,u})$.
- For DL-MU, AP indicates common N_{sym} , *a-factor*, LDPC Extra Symbol indication, and T_{PE} in the HE-SIG field for all users.

DL-MU Padding Method (2)

- Illustration (DL-OFDMA)

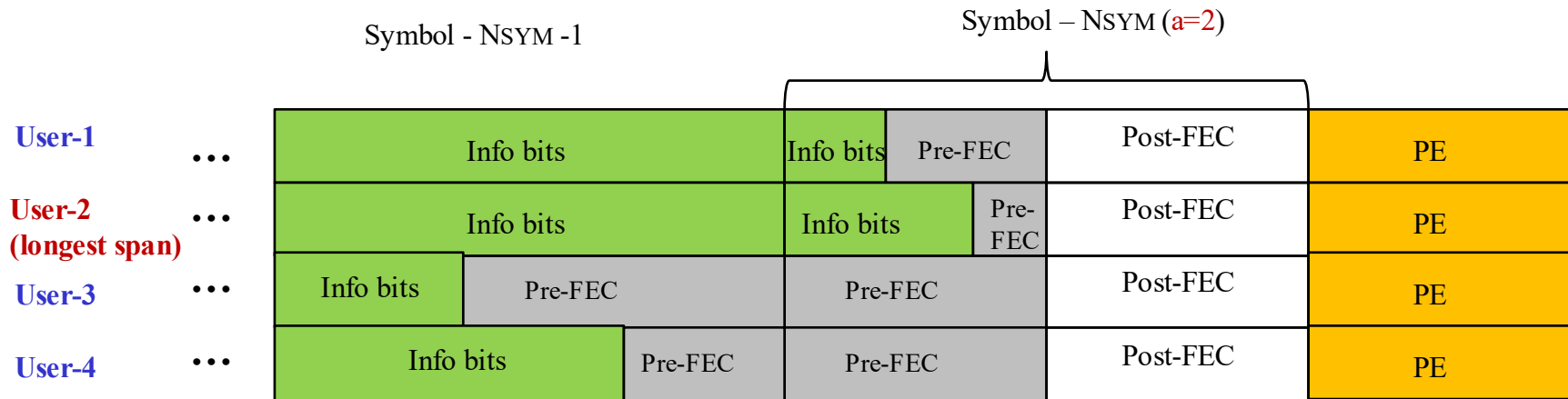

UL-MU Padding Method

- In UL-MU, AP does not have exact number of bytes in each user's buffer—hence cannot compute *a-factor* on a per user basis like SU and DL-MU. However, the STA can use pre-FEC padding to fill N_{sym} long symbols + *a-factor* short segments.
- Prefer a common *a-factor* design similar to DL-MU, i.e.
 - AP indicates common N_{sym} , *a-factor*, LDPC Extra Symbol indication, and TPE for all users, in the trigger frame.
 - BCC users always pre-FEC pad to the pre-determined *a-factor*.
 - LDPC users:
 - If LDPC Extra Symbol = 1, always pre-FEC pad to $a_{\text{init}} = a - 1$ in the last symbol(s), and always apply LDPC extra symbol using the last symbol segment ($a = a_{\text{init}} + 1$).
 - If LDPC Extra Symbol = 0, always pre-FEC pad to $a_{\text{init}} = a$ in the last symbol(s), and always do not apply LDPC extra symbol.

Wilus Institute of Standards and Technology Inc.,

Ex. 2022, IPR2025-01069

Page 21 of 38

SIG Field Signaling (1)

- HE-SIG Field:
 - 2-bits for *a-factor* .
 - 1 bit for PE dis-ambiguity .
 - For receiver to derive correct T_{PE} and N_{SYM} without ambiguity.
- *a-factor* field definition:

<i>a</i>	<i>HE – SIG field Encoding</i>
1	01
2	10
3	11
4	00

SIG Field Signaling (2)

- Timing Parameters:

$$TXTIME = T_{L_PREAMBLE} + T_{HE_PREAMBLE} + T_{HE_DATA} + T_{PE}$$

where $T_{HE_DATA} = T_{HE_SYM} \times N_{SYM} = (12.8 + T_{GI}) \times N_{SYM}$

- L-SIG:

$$TXTIME = T_{L_PREAMBLE} + T_{HE_PREAMBLE} + T_{HE_DATA} + T_{PE}$$

$$L_LENGTH = \left\lceil \frac{TXTIME - 20}{4} \right\rceil \times 3 - 3 + m, \quad m = 1 \text{ or } 2$$

SIG Field Signaling (3)

- HE-SIG-A: “PE-Disambiguity” Field:
 - Tx: if the following is met, set this field to 1; otherwise, set to 0.

$$T_{PE} + 4 \times \left(\left\lceil \frac{TXTIME - 20}{4} \right\rceil - \left(\frac{TXTIME - 20}{4} \right) \right) \geq T_{SYM}$$

- Rx Side Computation:

$$N_{SYM} = \left\lfloor \left(\frac{L_LENGTH - m + 3}{3} \times 4 - T_{HE_PREAMBLE} \right) / T_{SYM} \right\rfloor - b_{PE_Disambiguity}$$

$$T_{PE} = \left\lfloor \frac{\left(\frac{L_LENGTH - m + 3}{3} \times 4 - T_{HE_PREAMBLE} \right) - N_{SYM} \times T_{SYM}}{4} \right\rfloor \times 4$$

Simulations: LDPC Performance Sanity Check

- Simulate the same MCS for 11ax and 11ac.
- 80MHz, 4 Rx 3SS, LDPC, DNLOS channel.
- For sanity check purpose, we tried different packet sizes to trigger difference scenarios:
 - L=16K Bytes, MCS9-3SS.
 - 11ax padding Op4: 7 symbols, $a = 3$, no LDPC additional symbol;
 - 11ac: 28 symbols , no additional symbol.
 - L=15000 bits, MCS7-3SS
 - 11ax padding Op4: 2 symbols, $a = 1$, no LDPC additional symbol;
 - 11ac: 5 symbols , no LDPC additional symbol.
 - L= 5000 bits, MCS7-3SS
 - 11ax padding Op4: 1 symbols, $a = 3$, **with LDPC additional symbol**;
 - 11ac: 3 symbols , **with LDPC additional symbol**.
 - L= 3150 bits, MCS7-3SS
 - 11ax padding Op4: 1 symbols, $a = 3$, **with LDPC additional symbol**;
 - 11ac: 2 symbols , **with LDPC additional symbol**.

Results

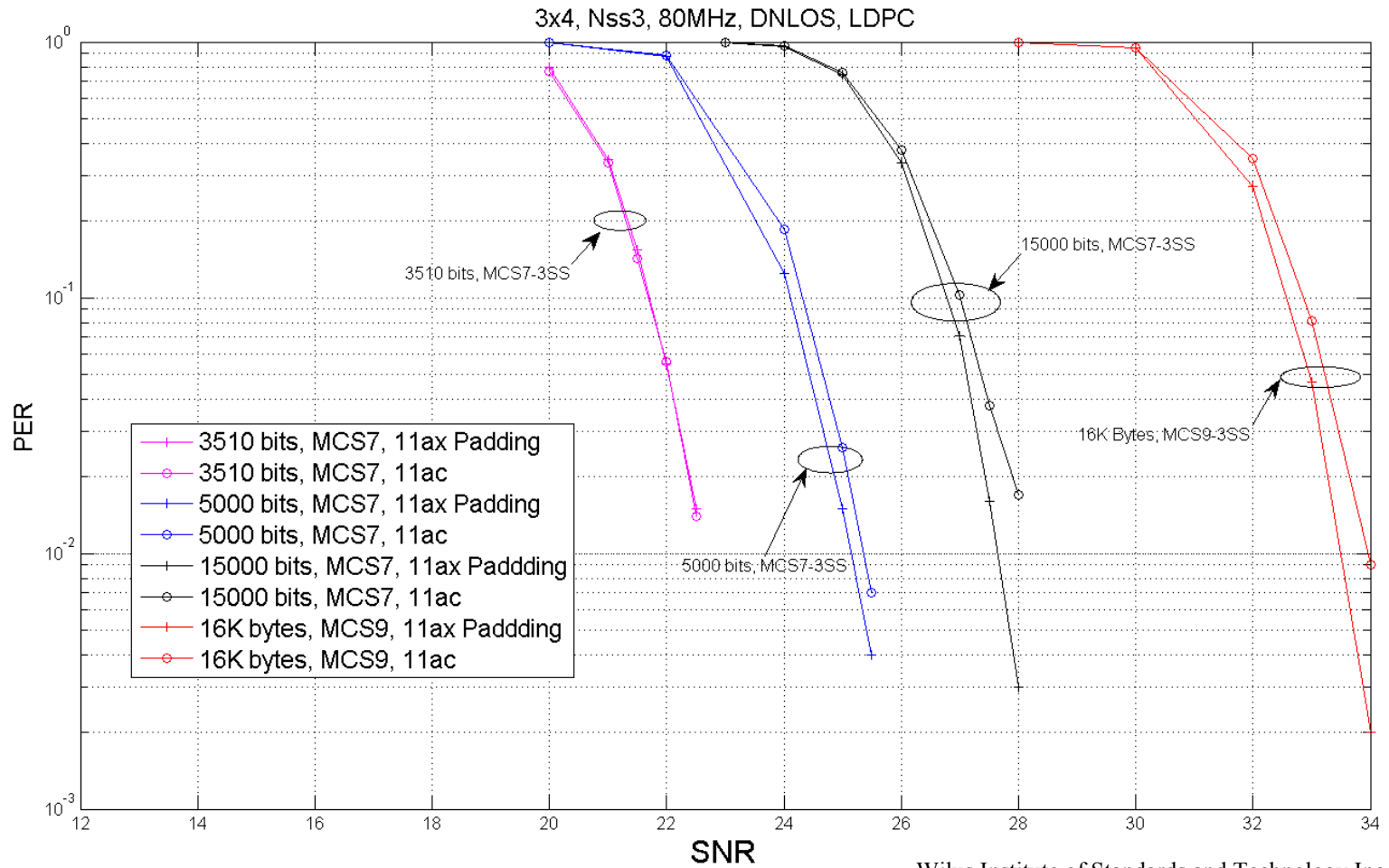

Conclusions

- A HE PHY padding and Packet Extension method is proposed to address the area and overhead concern caused by 11ax 4x OFDM numerology.
- The two-step padding and variable PE duration properly addresses the tradeoff between implementation complexity and HE-PHY overhead.
- Further discussions on detailed padding parameters; PE capability definition; MU padding methods; and PHY signaling in HE-SIG.

Straw Poll #1

- Do you agree to add the following text into Section 3.4 HE Data Field of the current SFD:
 - An 11ax SU PPDU should apply the MAC/PHY pre-FEC padding scheme as in 11ac, to pad toward the nearest of the four possible boundaries (“*a*” factor) in the last Data OFDM symbol(s), and then use post-FEC padding bits to fill up the last OFDM symbol(s).
 - Packet Extension (PE) field is defined at the end of 11ax PPDUs.
 - PE should have the same average power as data field.

Appendix: Example Math for SU Padding

Initiating Parameters

$$N_{CBPS,short} = N_{SD,short} \cdot N_{SS} \cdot N_{BPSCS}$$

$$N_{DBPS,short} = N_{CBPS,short} \cdot R$$

Where $N_{SD,short}$ is defined as in below table:

RU Size	$N_{SD,Short}$
26	6
52	12
106	24
242	60
484	120
996	240
996x2	492

Wilus Institute of Standards and Technology Inc.,
Ex. 2022, IPR2025-01069
Page 30 of 38

Step-1

- Compute initial number of payload symbols.

– BCC:

$$N_{SYM.init} = m_{STBC} \cdot \left\lceil \frac{8 \cdot APEP_LENGTH + N_{Tail} \cdot N_{ES} + N_{service}}{m_{STBC} \cdot N_{DBPS}} \right\rceil$$

– LDPC:

$$N_{SYM.init} = m_{STBC} \cdot \left\lceil \frac{8 \cdot APEP_LENGTH + N_{service}}{m_{STBC} \cdot N_{DBPS}} \right\rceil$$

Step-2

- Compute initial numbers of data bits and coded bits in the last symbol and initial excess factor a value, based on number of excess bits:

- BCC:
$$N_{\text{Excess}} = \text{mod}(8 \cdot \text{APEP_LENGTH} + N_{\text{Tail}} \cdot N_{\text{ES}} + N_{\text{service}}, m_{\text{STBC}} \cdot N_{\text{DBPS}})$$

- LDPC:
$$N_{\text{Excess}} = \text{mod}(8 \cdot \text{APEP_LENGTH} + N_{\text{service}}, m_{\text{STBC}} \cdot N_{\text{DBPS}})$$

- Initial a -factor value:

If $0 < N_{\text{Excess}} \leq m_{\text{STBC}} \cdot N_{\text{DBPS.SHORT}}$, then $a_{\text{init}} = 1$

If $m_{\text{STBC}} \cdot N_{\text{DBPS.SHORT}} < N_{\text{Excess}} \leq 2 \cdot m_{\text{STBC}} \cdot N_{\text{DBPS.SHORT}}$, then $a_{\text{init}} = 2$

If $2 \cdot m_{\text{STBC}} \cdot N_{\text{DBPS.SHORT}} < N_{\text{Excess}} \leq 3 \cdot m_{\text{STBC}} \cdot N_{\text{DBPS.SHORT}}$, then $a_{\text{init}} = 3$

If $3 \cdot m_{\text{STBC}} \cdot N_{\text{DBPS.SHORT}} < N_{\text{Excess}} \leq m_{\text{STBC}} \cdot N_{\text{DBPS}}$, or $N_{\text{Excess}} = 0$, then $a_{\text{init}} = 4$

$$N_{\text{DBPS.LAST.init}} = \begin{cases} a_{\text{init}} \cdot N_{\text{DBPS.SHORT}}, & \text{if } a_{\text{init}} < 4 \\ N_{\text{DBPS}}, & \text{if } a_{\text{init}} = 4 \end{cases}$$

$$N_{\text{CBPS.LAST.init}} = \begin{cases} a_{\text{init}} \cdot N_{\text{CBPS.SHORT}}, & \text{if } a_{\text{init}} < 4 \\ N_{\text{CBPS}}, & \text{if } a_{\text{init}} = 4 \end{cases}$$

Step-3

- Compute number of (pre-FEC) MAC/PHY padding bits as below, and conduct MAC/PHY Padding as in 11ac.

– BCC:

$$N_{PAD,PRE-FEC} = (N_{SYM.init} - m_{STBC}) \cdot N_{DBPS} + m_{STBC} \cdot N_{DBPS.LAST.init} \\ - 8 \cdot APEP_LENGTH - N_{Tail} \cdot N_{ES} - N_{service}$$

– LDPC:

$$N_{PAD,PRE-FEC} = (N_{SYM.init} - m_{STBC}) \cdot N_{DBPS} + m_{STBC} \cdot N_{DBPS.LAST.init} \\ - 8 \cdot APEP_LENGTH - N_{service}$$

Step-4

- **FEC coding and Compute final N_{SYM} and a -factor:**

- BCC: $N_{SYM} = N_{SYM.init}$, $a = a_{init}$

- Then conduct regular BCC coding based on these parameters.

- LDPC: $N_{pld} = (N_{SYM.init} - m_{STBC}) \cdot N_{DBPS} + m_{STBC} \cdot N_{DBPS.LAST.init}$

$$N_{avbits} = (N_{SYM.init} - m_{STBC}) \cdot N_{CBPS} + m_{STBC} \cdot N_{CBPS.LAST.init}$$

- Compute LDPC encoding parameters $\{LLDPC, NCW, Nshrt, Npunc\}$ as in 802.11n (clause **20.3.11.7.5**) starting from N_{avbits} .
- In step d) of clause **20.3.11.7.5**, if the condition for “LDPC Extra Symbol” is met, then

$$N_{avbits} = \begin{cases} N_{avbits} + m_{STBC} \cdot (N_{CBPS} - 3 \cdot N_{CBPS.SHORT}), & \text{if } a_{init} = 3 \\ N_{avbits} + m_{STBC} \cdot N_{CBPS.SHORT}, & \text{otherwise} \end{cases}$$

$$N_{punc} = \max(0, (N_{CW} \times L_{LDPC}) - N_{avbits} - N_{shrt})$$

$$\begin{cases} N_{SYM} = N_{SYM.init} + m_{STBC}, \text{ and } a = 1, & \text{if } a_{init} = 4 \\ N_{SYM} = N_{SYM.init}, \text{ and } a = a_{init} + 1, & \text{otherwise} \end{cases}$$

Step-4 (Cont'd)

- (LDPC Cont'd) if the above mentioned “LDPC Extra Symbol” condition is not met:

$$a = a_{init}, N_{SYM} = N_{SYM.init}$$

- Conduct Regular LDPC encoding using these parameters.

– Finally, update below:

$$N_{CBPS.LAST} = \begin{cases} a \cdot N_{CBPS.SHORT}, & \text{if } a < 4 \\ N_{CBPS}, & \text{if } a = 4 \end{cases}$$

Step-5

- **Post-FEC padding and remaining Tx steps:**

$$N_{PAD,POST-FEC} = N_{CBPS} - N_{CBPS.LAST}$$

- Pad $N_{PAD,POST-FEC}$ bits after encoded bits in each of the last m_{STBC} OFDM symbols, and then continue with the following transmission steps

Step-6

- **Packet Extension Insertion:**
 - Insert Packet Extension Field at the end of the PPDU, according to *a-factor* value, the MCS, BW and Nss parameters used in the data field, and the PE capability of the intended recipient of the PPDU

References

- [1] 11-15-0132-02-00ax-spec-framework
- [2] 11-15-0580-01-00ax 11ax coding discussion