

IN THE UNITED STATES PATENT AND TRADEMARK OFFICE

BEFORE THE PATENT TRIAL AND APPEAL BOARD

Caption Health, Inc.
Petitioner

v.

University of British Columbia
Patent Owner

U.S. PATENT NO. 10,751,029
Filing Date: August 30, 2019
Issue Date: August 25, 2020
Title: ULTRASONIC IMAGE ANALYSIS

Inter Partes Review No.: IPR2025-01422

**PETITION FOR *INTER PARTES* REVIEW OF
U.S. PATENT NO. 10,751,029**

Mail Stop: Patent Board
Patent Trial and Appeal Board
U.S. Patent and Trademark Office
P.O. Box 1450
Alexandria, VA 22313-1450

CAPTION HEALTH Ex1030
Caption Health, Inc. v.
University of British Columbia
Trial IPR2025-01066

TABLE OF CONTENTS

I. PRELIMINARY STATEMENT.....	1
II. MANDATORY NOTICES (37 C.F.R. §42.8(A)(1))	2
A. Real Party-in-Interest (37 C.F.R. §42.8(b)(1)).....	2
B. Related Matters (37 C.F.R. §42.8(b)(2)).....	2
C. Lead and Back-up Counsel and Service Information (37 C.F.R. §42.8(b)(3)-(4)).....	3
III. GROUNDS FOR STANDING AND FEES	3
IV. BACKGROUND STATE OF THE ART	4
V. THE PATENT AND PROSECUTION HISTORY	5
A. The Specification.....	6
B. The Prosecution History	8
VI. IDENTIFICATION OF CHALLENGE.....	9
VII. LEVEL OF SKILL IN THE ART.....	9
VIII. CLAIM CONSTRUCTION (37 C.F.R. §42.100(b)).....	10
A. “means for receiving signals representing a set of ultrasound images of the subject” (Claim 30).....	10
B. “means for deriving one or more extracted feature representations from the set of ultrasound images” (Claim 30).....	10
C. “means for determining, based on the derived one or more extracted feature representations, a quality assessment value representing a quality assessment of the set of ultrasound images” (Claim 30).....	11
D. “means for determining, based on the derived one or more extracted feature representations, an image property associated with the set of ultrasound images” (Claim 30).....	11
E. “means for producing signals representing the quality assessment value and the image property for causing the quality assessment value and the image property to be associated with the set of ultrasound images” (Claim 30).....	11
IX. DETAILED EXPLANATION OF INVALIDITY GROUNDS.....	12
A. Summary of the Prior Art.....	12
1. US2005/0251013 (“Krishnan”).....	12

2. US2019/0076127 (“Aase”)	16
3. Automatic Fetal Ultrasound Standard Plane Detection (“Chen”)	17
4. Fetal Ultrasound Image Quality Assessment With Deep Convolutional Networks (“Wu”)	19
B. Ground A: Anticipation by Krishnan	20
1. Claim 1: Method Claim	20
2. Claim 2: “The method of claim 1, wherein the image property is a view category.”	34
3. Claim 3: “The method of claim 2 wherein deriving the one or more extracted feature representations from the ultrasound images comprises, for each of the ultrasound images, deriving a first feature representation associated with the ultrasound image.”	35
4. Claim 9: A Quality Assessment Value Specific Neural Network and an Image Property Specific Neural Network	36
5. Claim 11: Causing to be Displayed	37
6. Claim 21: System Claim	38
7. Claim 22: “The system of claim 21 wherein the image property is a view category.”	39
8. Claim 27: A Quality Assessment Value Specific Neural Network and an Image Property Specific Neural Network	39
9. Claim 29: Causing to be Displayed	41
10. Claim 30: Means-Plus-Function Claim	41
C. Ground B: Obviousness over Krishnan in view of Chen	51
1. Claim 3	51
2. Claim 4: “The method of claim 3 wherein deriving the one or more extracted feature representations comprises, for each of the ultrasound images, inputting the ultrasound image into a commonly defined first feature extracting neural subnetwork to generate the first feature representation associated with the ultrasound image.”	56
3. Claim 5: “The method of claim 4 wherein deriving the one or more extracted feature representations comprises concurrently inputting each of a plurality of the ultrasound images into a respective implementation of the commonly defined first feature extracting neural network.”	58

4. Claim 6: “The method of claim 4, wherein the commonly defined first feature extracting neural network includes a convolutional neural network.”	59
5. Claim 7: “The method of claim 4 wherein deriving the one or more extracted feature representations comprises inputting the first feature representations into a second feature extracting neural network to generate respective second feature representations, each associated with one of the ultrasound images and wherein the one or more extracted feature representations include the second feature representations.”	60
6. Claim 8: “The method of claim 7 wherein the second feature extracting neural network is a recurrent neural network.”	62
7. Claim 23	62
8. Claim 24	63
9. Claim 25	63
10. Claim 26	64
D. Ground C: Obviousness Over Krishnan in view of Aase	64
1. Claims 9 and 27: A Quality Assessment Value Specific Neural Network and an Image Property Specific Neural Network.....	64
2. Claims 10 and 28 (“[10]/[28]”).....	68
E. Ground D: Obviousness over Krishnan in view of Chen and Wu	69
1. Claim 12	70
2. Claim 13: “The method of claim 12, wherein the image property is a view category.”	79
3. Claim 14: A Feature Extracting Neural Network, Image Property Specific Neural Network, and Quality Assessment Value Specific Neural Network.	79
4. Claim 15: “The method of claim 14, wherein the feature extracting neural network is configured to, for each of the ultrasound training images included in the input set of ultrasound training images, derive a first feature representation associated with the ultrasound image.”	80
5. Claim 16: “The method of claim 15, wherein the feature extracting neural network includes, for each of the ultrasound images included in the input set of ultrasound training images, a commonly defined first feature extracting neural network configured to take as an input the	

ultrasound training image and to output a respective one of the first feature representations.”81

6. Claim 17: “The method of claim 16 wherein more than one implementation of the commonly defined first feature extracting neural networks are configured to concurrently generate the first feature representations.”83

7. Claim 18: “The method of claim 16 wherein the commonly defined first feature extracting neural network is a convolutional neural network.”84

8. Claim 19: Second Feature Extracting Neural Network84

9. Claim 20: “The method of claim 19 wherein the second feature extracting neural network is a recurrent neural network.”87

X. CONCLUSION87

EXHIBIT LIST

No.	Description
Ex1001	U.S. Patent No. 10,751,029 (“the Patent”)
Ex1002	Declaration of Dr. Rahul Deo
Ex1003	Dr. Deo Curriculum Vitae
Ex1004	Prosecution History File of the Patent (Application No. 16/557,261)
Ex1005	U.S. Patent Application Publication No. 2005/0251013 (“Krishnan”)
Ex1006	U.S. Patent Application Publication No. 2019/0076127 (“Aase”)
Ex1007	U.S. Patent No. 10,013,640 (“Angelova”)
Ex1008	International Patent Application Publication No. WO2016/189313 (“Paterson”)
Ex1009	Chen, “Automatic Fetal Ultrasound Standard Plane Detection Using Knowledge Transferred Recurrent Neural Networks,” <i>Medical Image Computing and Computer-Assisted Intervention – MICCAI 2015</i> : 507-514 (November 18, 2015), https://doi.org/10.1007/978-3-319-24553-9_62 (“Chen”)
Ex1010	Wu, “FUIQA: Fetal Ultrasound Image Quality Assessment With Deep Convolutional Networks,” <i>IEEE Transactions on Cybernetics</i> , 47(5):1336-1349 (May 2017), doi: 10.1109/TCYB.2017.2671898 (“Wu”)
Ex1011	First Amended Complaint, <i>University of British Columbia v. Caption Health, Inc.</i> , Case No. 5:24-cv-03200-EKL, Dkt. 46, Dec. 20, 2024.
Ex1012	Itchhaporla, “Artificial Neural Networks: Current Status in Cardiovascular Medicine,” <i>JACC</i> 28(2): 515-521 (August 1996) (“Itchhaporla”)
Ex1013	Chen, “Iterative Multi-domain Regularized Deep Learning for Anatomical Structure Detection and Segmentation from Ultrasound Images,” <i>Medical Image Computing and Computer-Assisted Intervention–MICCAI 2016</i> : 487-495 (October 2, 2016)
Ex1014	Kong, “Recognizing End-Diastole and End-Systole Frames via Deep Temporal Regression Network,” <i>Medical Image Computing and Computer-Assisted Intervention—MICCAI 2016</i> : 264-272 (2016), DOI:10.1007/978-3-319-46726-9_31

Ex1015	Joint Claim Construction and Prehearing Statement, <i>University of British Columbia v. Caption Health, Inc.</i> , Case No. 5:24-cv-03200-EKL, Dkt. 68, May 30, 2025.
Ex1016	Chen, “Standard plane localization in fetal ultrasound via domain transferred deep neural networks,” <i>IEEE Journal of Biomedical and Health Informatics</i> , 19(5): 1627-1636 (September 2015), DOI:10.1109/JBHI.2015.2425041 (“Chen I”)
Ex1017	Miller et al., “Review of neural network applications in medical imaging and signal processing,” <i>Medical & Biological Engineering & Computing</i> (30):449-464 (September 1992) (“Miller”)
Ex1018	U.S. Patent Application Publication No. 2017/0262982 (“Pagoulatos”)
Ex1019	Reserved
Ex1020	González et al., “Echocardiogram Image Recognition Using Neural Networks in Recent Advances on Hybrid Approaches for Designing Intelligent Systems,” <i>Studies in Computational Intelligence</i> 547:427-435 (March 2014) (“González”)
Ex1021	Donahue et al., “Long-term Recurrent Convolutional Networks for Visual Recognition and Description,” arXiv:1411.4389v1 [cs.CV] (November 2014) (“Donahue”)
Ex1022	Caruana, “Multitask Learning: A Knowledge-Based Source of Inductive Bias,” <i>Proceedings of the 10th International Conference on Machine Learning, ML-93</i> , University of Massachusetts, Amherst, 1993, pp. 41-48.
Ex1023	U.S. Patent No. 5,906,578 (“Rajan”)
Ex1024	U.S. Patent Application Publication No. 2009/0074280 (“Lu”)
Ex1025	U.S. Patent Application Publication No. 2007/0055153 (“Simopoulos”)
Ex1026	Salomon LJ et al. A score-based method for quality control of fetal images at routine second-trimester ultrasound examination. <i>Prenat Diagn.</i> 2008 Sep;28(9):822-7. doi: 10.1002/pd.2016. PMID: 18646244
Ex1027	LeCun et al., “Handwritten Digit Recognition with a Back-Propagation Network,” <i>Neural Computation</i> . 1 (4): 541–551. doi:10.1162/neco.1989.1.4.541. ISSN 0899-7667. S2CID 41312633 (“LeCun”)

Ex1028	A. Bouzerdoun, et al., "Image quality assessment using a neural network approach," Proceedings of the Fourth IEEE International Symposium on Signal Processing and Information Technology, 2004., Rome, Italy, 2004, pp. 330-333, doi: 10.1109/ISSPIT.2004.1433751 ("Bouzerdoun")
Ex1029	A. Krizhevsky, et al., "ImageNet classification with deep convolutional neural networks," Communications of the ACM, Volume 60, Issue 6, pp. 84-90 doi: 10.1145/3065386 (June 2017) ("Krizhevsky")

CLAIMS APPENDIX

Limitation	Claim Language
Claim 1	
[1(pre)]	1. A computer-implemented method of facilitating ultrasonic image analysis of a subject, the method comprising:
[1(a)]	receiving signals representing a set of ultrasound images of the subject;
[1(b)]	deriving one or more extracted feature representations from the set of ultrasound images;
[1(c)]	determining, based on the derived one or more extracted feature representations, a quality assessment value representing a quality assessment of the set of ultrasound images;
[1(d)]	determining, based on the derived one or more extracted feature representations, an image property associated with the set of ultrasound images; and
[1(e)]	producing signals representing the quality assessment value and the image property for causing the quality assessment value and the image property to be associated with the set of ultrasound images.
Claim 2	
[2]	The method of claim 1 wherein the image property is a view category.
Claim 3	
[3]	The method of claim 2 wherein deriving the one or more extracted feature representations from the ultrasound images comprises, for each of the ultrasound images, deriving a first feature representation associated with the ultrasound image.
Claim 4	
[4]	The method of claim 3 wherein deriving the one or more extracted feature representations comprises, for each of the ultrasound images, inputting the ultrasound image into a commonly defined first feature extracting neural subnetwork to generate the first feature representation associated with the ultrasound image.
Claim 5	
[5]	The method of claim 4 wherein deriving the one or more extracted feature representations comprises concurrently inputting each of a plurality of the ultrasound images into a respective implementation of the commonly defined first feature extracting neural network.
Claim 6	

[6]	The method of claim 4 wherein the commonly defined first feature extracting neural network includes a convolutional neural network.
Claim 7	
[7]	The method of claim 4 wherein deriving the one or more extracted feature representations comprises inputting the first feature representations into a second feature extracting neural network to generate respective second feature representations, each associated with one of the ultrasound images and wherein the one or more extracted feature representations include the second feature representations.
Claim 8	
[8]	The method of claim 7 wherein the second feature extracting neural network is a recurrent neural network.
Claim 9	
[9]	The method of claim 2 wherein determining the quality assessment value comprises inputting the one or more extracted feature representations into a quality assessment value specific neural network and wherein determining the image property comprises inputting the one or more extracted feature representations into an image property specific neural network.
Claim 10	
[10]	The method of claim 9 wherein inputting the one or more extracted feature representations into the quality assessment value specific neural network comprises inputting each of the one or more extracted feature representations into an implementation of a commonly defined quality assessment value specific neural subnetwork and wherein inputting the one or more extracted feature representations into the image property determining neural network comprises inputting each of the one or more extracted feature representations into an implementation of a commonly defined image property specific neural network.
Claim 11	
[11]	The method of claim 2 wherein producing signals representing the quality assessment value and the image property for causing the quality assessment value and the image property to be associated with the set of ultrasound images comprises producing signals for causing a representation of the quality assessment value and a representation of the image property to be displayed by at least one display in association with the set of ultrasound images.

Claim 12	
[12(pre)]	A computer-implemented method of training one or more neural networks to facilitate ultrasonic image analysis, the method comprising:
[12(a)]	receiving signals representing a plurality of sets of ultrasound training images;
[12(b)]	receiving signals representing quality assessment values, each of the quality assessment values associated with one of the sets of ultrasound training images and representing a quality assessment of the associated set of ultrasound training images;
[12(c)]	receiving signals representing image properties, each of the image properties associated with one of the sets of ultrasound training images; and
[12(d)]	training a neural network, the training comprising, for each set of the plurality of sets of ultrasound training images, using the set of ultrasound training images as an input to the neural network and using the quality assessment values and the image properties associated with the set of ultrasound training images as desired outputs of the neural network.
Claim 13	
[13]	The method of claim 12 wherein each of the image properties is a view category.
Claim 14	
[14(pre)]	The method of claim 13 wherein the neural network includes a feature extracting neural network, an image property specific neural network, and a quality assessment value specific neural network and wherein:
[14(a)]	the feature extracting neural network is configured to take an input set of the plurality of sets of ultrasound training images as an input and to output one or more extracted feature representations;
[14(b)]	the image property specific neural network is configured to take the one or more extracted feature representations as an input and to output a representation of an image property associated with the input set of ultrasound training images; and
[14(c)]	the quality assessment specific neural network is configured to take the one or more extracted feature representations as an input and to output a quality assessment value associated with the input set of ultrasound training images.
Claim 15	

[15]	The method of claim 14 wherein the feature extracting neural network is configured to, for each of the ultrasound training images included in the input set of ultrasound training images, derive a first feature representation associated with the ultrasound image.
Claim 16	
[16]	The method of claim 15 wherein the feature extracting neural network includes, for each of the ultrasound images included in the input set of ultrasound training images, a commonly defined first feature extracting neural network configured to take as an input the ultrasound training image and to output a respective one of the first feature representations.
Claim 17	
[17]	The method of claim 16 wherein more than one implementation of the commonly defined first feature extracting neural networks are configured to concurrently generate the first feature representations.
Claim 18	
[18]	The method of claim 16 wherein the commonly defined first feature extracting neural network is a convolutional neural network.
Claim 19	
[19]	The method of claim 16 wherein the feature extracting neural network includes a second feature extracting neural network configured to take as an input the first feature representations and to output respective second feature representations, each associated with one of the ultrasound images included in the input set of ultrasound training images and wherein the one or more extracted feature representations include the second feature representations.
Claim 20	
[20]	The method of claim 19 wherein the second feature extracting neural network is a recurrent neural network.
Claim 21	
[21(pre)]	A system for facilitating ultrasonic image analysis comprising at least one processor configured to:
[21(a)]	receive signals representing a set of ultrasound images of the subject;
[21(b)]	derive one or more extracted feature representations from the set of ultrasound images;
[21(c)]	determine, based on the derived one or more extracted feature representations, a quality assessment value representing a quality assessment of the set of ultrasound images;

[21(d)]	determine, based on the derived one or more extracted feature representations, an image property associated with the set of ultrasound images; and
[21(e)]	produce signals representing the quality assessment value and the image property for causing the quality assessment value and the image property to be associated with the set of ultrasound images.
Claim 22	
[22]	he system of claim 21 wherein the image property is a view category.
Claim 23	
[23]	The system of claim 22 wherein the at least one processor is configured to, for each of the ultrasound images, input the ultrasound image into a commonly defined first feature extracting neural subnetwork to generate a first feature representation associated with the ultrasound image.
Claim 24	
[24]	The system of claim 23 wherein the at least one processor is configured to, for each of the ultrasound images, input the ultrasound image into a commonly defined first feature extracting neural subnetwork to generate the first feature representation associated with the ultrasound image.
Claim 25	
[25]	The system of claim 24 wherein the at least one processor is configured to concurrently input each of a plurality of the ultrasound images into a respective implementation of the commonly defined first feature extracting neural network.
Claim 26	
[26]	he system of claim 24 wherein the at least one processor is configured to input the first feature representations into a second feature extracting neural network to generate respective second feature representations, each associated with one of the ultrasound images and wherein the one or more extracted feature representations include the second feature representations.
Claim 27	
[27]	The system of claim 22 wherein the at least one processor is configured to input the one or more extracted feature representations into a quality assessment value specific neural network and to input the one or more extracted feature representations into an image property specific neural network.

Claim 28	
[28]	The system of claim 27 wherein the at least one processor is configured to input each of the one or more extracted feature representations into an implementation of a commonly defined quality assessment value specific neural subnetwork and to input each of the one or more extracted feature representations into an implementation of a commonly defined image property specific neural network.
Claim 29	
[29]	The system of claim 22 wherein the at least one processor is configured to produce signals for causing a representation of the quality assessment value and a representation of the image property to be displayed by at least one display in association with the set of ultrasound images.
Claim 30	
[30(pre)]	A system for facilitating ultrasonic image analysis, the system comprising:
[30(a)]	means for receiving signals representing a set of ultrasound images of the subject;
[30(b)]	means for deriving one or more extracted feature representations from the set of ultrasound images;
[30(c)]	means for determining, based on the derived one or more extracted feature representations, a quality assessment value representing a quality assessment of the set of ultrasound images;
[30(d)]	means for determining, based on the derived one or more extracted feature representations, an image property associated with the set of ultrasound images; and
[30(e)]	means for producing signals representing the quality assessment value and the image property for causing the quality assessment value and the image property to be associated with the set of ultrasound images.

I. PRELIMINARY STATEMENT

Petitioner requests *inter partes* review (IPR) and a finding that claims 1-30 of U.S. Patent No. 10,751,029 (“the Patent,” Ex1001) are invalid.

The Patent is directed to a computer-implemented method of analyzing ultrasound images by extracting features of the images and using the extracted features to determine an image property (e.g., a view category) of the images and their quality. Ex1001, Abstract. The steps recited in claim 1 are illustrative and are schematically depicted in Figure 3 of the Patent, which is reproduced below side-by-side with a *strikingly similar* figure from US2005/0251013 (“Krishnan”).

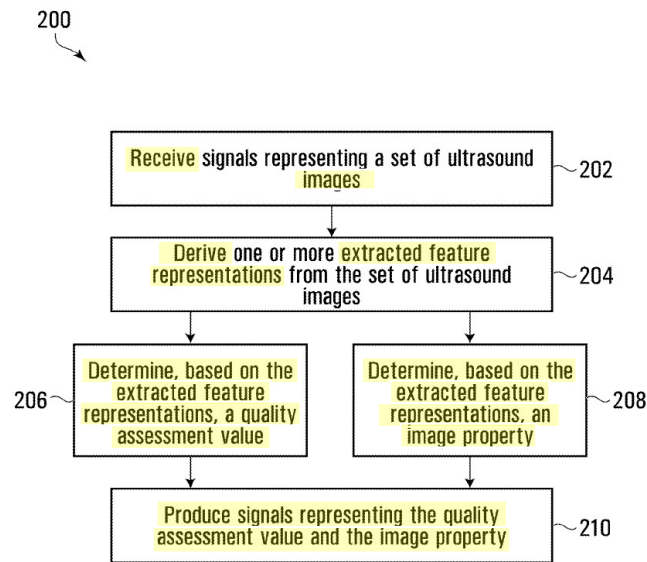

Fig. 3 of the Patent (Ex1001)

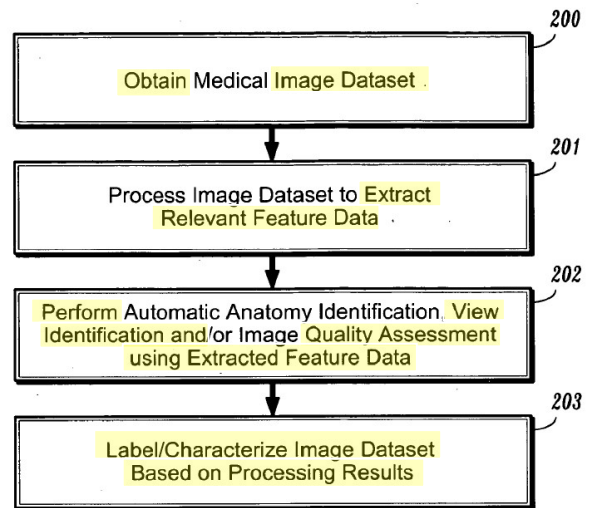

Fig. 2 of Krishnan (Ex1005)

Krishnan is prior art to the Patent by more than ten years. Like the Patent, Krishnan is directed to a computer-implemented method of analyzing a set of

ultrasound images (Ex1005, [0016], [0033]) by extracting features of the images (*id.*, [0017]) and using the extracted features to determine the view category (*id.* [0019], [0034]) and quality (*id.*, [0020], [0034]) of the set of images. Like the Patent, Krishnan also automatically labels the analyzed images with their view category and quality assessment value to provide real-time feedback during ultrasound image acquisition. *Id.*, [0019]-[0020], [0032].

As detailed herein, Krishnan anticipates many claims of the Patent and, in combination with other references, renders the remaining claims of the Patent obvious. Accordingly, Petitioner respectfully requests institution of trial and invalidation of all claims. Ex1002, ¶¶1-5,6-15, 101-102.

II. MANDATORY NOTICES (37 C.F.R. §42.8(A)(1))

A. Real Party-in-Interest (37 C.F.R. §42.8(b)(1))

The real parties-in-interest are Petitioner and Petitioner's parent company, GE HealthCare Technologies Inc.

B. Related Matters (37 C.F.R. §42.8(b)(2))

The University of British Columbia ("UBC" or "Patent Owner") has asserted U.S. Patent No. 10,751,029 ("the Patent") against Petitioner and Caption Health, Inc. in *University of British Columbia v. Caption Health, et al.*, 5:24-cv-03200-EKL (N.D. Cal.) ("California Litigation"). Ex1011. The earliest date of service is December 20, 2024.

U.S. Patent No. 11,129,591 ("the '591 patent") is also asserted against

Petitioner in the California Litigation. The '591 patent contains subject matter that overlaps with the subject matter described in the Patent. It is not, however, within the same patent family as the Patent and is not related to the Patent by any priority claim. Petitioner filed a Petition for *Inter Partes* Review of the '591 patent in IPR2025-01066. Ex1002, ¶¶16-17.

C. Lead and Back-up Counsel and Service Information (37 C.F.R. §42.8(b)(3)-(4))

Lead counsel is Jeff Metzcar (No. 52,027) at THOMPSON HINE LLP, 10050 Innovation Drive, Suite 400, Dayton, OH 45342; Jeff.Metzcar@thompsonhine.com. Backup counsel is David R. Jaglowski (No. 58,514) at THOMPSON HINE LLP, 41 South High Street, Suite 1700, Columbus, Ohio 43215; David.Jaglowski@thompsonhine.com. Supplemental backup counsel are Marla R. Butler (to be admitted *pro hac vice*) and William E. Manske (to be admitted *pro hac vice*) at THOMPSON HINE LLP. Petitioner consents to email service at the following address: IPDocket@ThompsonHine.com.

III. GROUNDS FOR STANDING AND FEES

Petitioner certifies that the Patent is available for *inter partes* review and Petitioner is not barred or estopped from requesting review.

The undersigned authorizes the charge of any required fees to Deposit Account No. 20-0809.

IV. BACKGROUND STATE OF THE ART

Ultrasound is a common medical imaging modality used to image diverse structures such as the abdomen, a fetus, and the heart. Ex1002, ¶¶36-40. The image observed by an ultrasound acquisition depends on the location of the probe on the body, its angle, and the amount of pressure placed on it. Ex1002, ¶38. Radiologists have adopted a series of standardized two-dimensional planes or “views” which highlight critical structures of interest. *Id.*, ¶39.

The manual acquisition of standard ultrasound views requires significant operator skill and experience. Ex1002, ¶40; Ex1009, p.508. Thus, a method for automatically determining, during acquisition, whether an ultrasound image corresponds to a standard view would be highly desirable. Ex1009, p.508; Ex1005, [0028]; Ex1002, ¶¶40,120-122,164. Likewise, a method for automatically assessing the diagnostic quality of ultrasound images would be highly desirable to eliminate subjective interobserver variability and provide real-time operator feedback. Ex1010, 1336-1337 (pdf pp.1-2); Ex1005, [0032]; Ex1002, ¶¶40,115-117,154.

No later than 1996, it was reported that: “Artificial neural networks are under investigation in the fields of image processing and interpretation ... and

being used to process images, to facilitate complex pattern recognition, which will aid classification of images into clinically relevant categories.” Ex1012, p.519¹. By 2015, a published study described the use of deep learning convolutional neural networks (CNNs) in combination with recurrent neural networks (RNNs) to recognize anatomic features in a set of ultrasound images (*e.g.*, video) and automatically determine whether the images correspond to standard views. *See generally*, Ex1009 (“Chen”). And, by May 2017, another published study reported using deep CNNs for “automatic quality assessment” of ultrasound images in specific view categories, which could be “easily generalized” to assess the quality of other views. *See generally*, Ex1010 (“Wu”). It is within the context of this “state of the art” that the Patent was filed. Ex1002, ¶¶41-57.

V. THE PATENT AND PROSECUTION HISTORY

The Patent issued on August 25, 2020, from Application No. 16/557,261, claiming priority to Provisional Application No. 62/725,913 filed on August 31, 2018. Ex1001; Ex1002, ¶¶18-19,58.

¹ Unless otherwise indicated, all emphasis, ellipses, and bracketed language has been added in the quotations and citations presented herein.

A. The Specification

The Patent is directed to a computer-implemented method for analyzing a set of ultrasound images to automatically determine the view category and quality of the set. Ex1001, 1:35-50, 3:23-27, Fig. 3. More specifically, the Patent describes inputting a set of images into one or more artificial neural networks that have been trained to perform the disclosed functions. *Id.*, 1:51-2:23, 6:35-7:3, 9:64-10:4, 10:21-31, 11:30-60, 12:58-13:8, 13:14-42, 13:49-14:3, 20:30-40, Fig. 4; Ex1002, ¶¶59-62. The claimed “set of ultrasound images” may be “a temporally ordered set of ultrasound images representing a video or cine of the subject” where “[e]ach image of the set of ultrasound images may be referred to herein as a frame.” Ex1001, 9:27-33; 6:5-9, 6:29-31, 9:51-58.

Referring to Figure 4, reproduced below, the Patent describes a main embodiment in which each image from the set of images is input into a respective, but “commonly defined,” first feature extracting neural network 304, 306, 308 (also referred to as sub-networks, annotated in red boxes). *Id.*, 10:21-42, 23:60-61. The Patent explains that “more than one of the commonly defined first feature extracting neural networks may be run concurrently,” for example “(CNN-1, CNN-2, CNN-3) in separate threads at the same time in order to prevent lag.” *Id.*, 11:43-50.

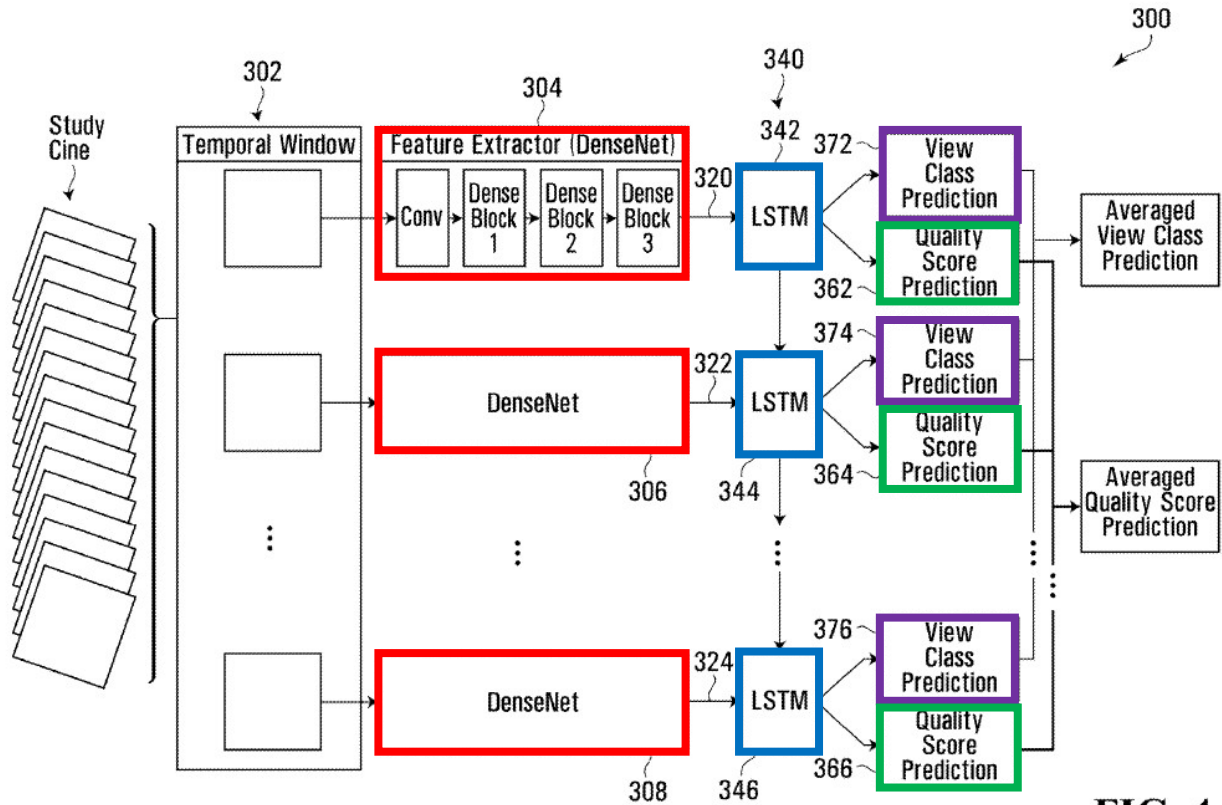

FIG. 4

The extracted first feature representations (e.g., as shown at 320, 322, and 324 in Figure 4) are then input into a second feature extracting neural network 340, which may include a plurality of recurrent neural networks (RNNs) (e.g., as shown at 342, 344, and 346 in Fig. 4, annotated in blue boxes). *Id.*, 11:51-12:13. “Referring to FIG. 4, each RNN (e.g., 342, 344, and 346 ...) may output a respective second feature representation, which may be used as an input for further processing.” *Id.* 12:20-23; Ex1002, ¶¶63-64.

Still referring to Figure 4, above, the respective second extracted feature representations are used as the inputs to respective quality assessment value

specific neural networks 362, 364, and 366 (also referred to as subnetworks, annotated in green boxes) to produce a quality assessment value for each of the input second feature representations. Ex1001, 12:62-66, 13:1-5; Ex1002, ¶65. The quality assessment value of the set of images may then be determined as, for example, “an average or mean of the quality assessment values output by the quality assessment value specific determining neural subnetworks.” Ex1001, 13:43-46. As with the respective feature extracting neural networks described above, each of the respective quality assessment neural networks may be “commonly defined ... by the same neural network parameters.” *Id.*, 13:1-8, 13:25-27.

Additionally, and in some cases concurrently (*id.*, 12:52-53), the respective second extracted feature representations are also used as the inputs to respective view category specific neural networks 372, 374, and 376 (annotated in purple boxes) configured to determine the view category for each of the input second feature representations. *Id.*, 13, 58-67; Ex1002, ¶66. The view category of the set of images may then be determined as, for example, “an average of the ... output by the view category specific determining neural subnetworks.” Ex1001, 14:48-50; Ex1002, ¶¶67-69.

B. The Prosecution History

The Patent was filed on August 30, 2019, requesting Track One prioritized

examination. Ex1004, p.2. On January 8, 2020, the Examiner issued a First Office Action rejecting every claim (1-30) under 35 U.S.C. §102(a)(2) as being anticipated by US2019/0125298. *Id.*, pp.265-288. On March 19, 2020, the Applicant removed US2019/0125298 as prior art under the exception in 35 U.S.C. §102(b)(2)(C) (*i.e.*, common ownership). *Id.*, pp.290-343. The Examiner did not substantively address any of the prior art references presented here, including Krishnan. Ex1002, ¶¶70-75.

VI. IDENTIFICATION OF CHALLENGE

Petitioner requests review of challenged claims 1-30 of the Patent as follows:

Ground	Prior Art	Basis	Claims Challenged
A	Krishnan	§102	1-3, 9, 11, 21-22, 27, 29-30
B	Krishnan in view of Chen (“Krishnan-Chen”)	§103	3-8, 23-26
C	Krishnan in view of Aase (“Krishnan-Aase”)	§103	9-10, 27-28
D	Krishnan in view of Chen and Wu (“Krishnan-Chen-Wu”)	§103	12-20

VII. LEVEL OF SKILL IN THE ART

The hypothetical person of ordinary skill in the art (“POSITA”) would include a person with an advanced degree in Computer Engineering, Computer Science, Physics, or other field related to computer imaging, and at least 1 year of research experience training machine learning models to analyze ultrasound data.

Ex1002, ¶¶6-17,33-35.

VIII. CLAIM CONSTRUCTION (37 C.F.R. §42.100(b))

Except for terms drafted in means-plus-function format, the claim terms of the Patent do not require an express construction. The prior art addressed herein discloses the claimed features under any reasonable interpretation of the claim language. Ex1002, ¶¶20,76-82.

A. “means for receiving signals representing a set of ultrasound images of the subject” (Claim 30)

In the California Litigation, Petitioner and Patent Owner have agreed that this term should be construed under 35 U.S.C. §112(f) and that the corresponding structure identified in the specification for performing the recited function is: “a processor with I/O interface.” Ex1015, p.2.; Ex1001, Fig. 2 (100, 112), 7:50-54, 7:61-63, 8:17-22.

B. “means for deriving one or more extracted feature representations from the set of ultrasound images” (Claim 30)

In the California Litigation, Petitioner and Patent Owner have agreed that this term should be construed under 35 U.S.C. §112(f) and that the corresponding structure/algorithm identified in the specification for performing the recited function is: “a processor and memory operating a neural network.” Ex1015, p.2.; Ex1001, Fig. 2 (100, 102, 104, 154, 156, 170), 1:55-2:7, 6:35-41, 7:50-52, 8:23-9:3, 9:64-10:2, 10:21-11:60, Fig. 4 (300, 304, 306, 308, 340, 342, 344, 346).

C. “means for determining, based on the derived one or more extracted feature representations, a quality assessment value representing a quality assessment of the set of ultrasound images” (Claim 30)

In the California Litigation, Petitioner and Patent Owner have agreed that this term should be construed under 35 U.S.C. §112(f) and that the corresponding structure identified in the specification for performing the recited function is: “a processor and memory operating a neural network.” Ex1015, p.2; Ex1001, Fig. 2 (100, 102, 104, 142, 144, 158, 170), 2:8-10, 2:14-19, 6:42-48, 7:50-52, 8:23-9:3, 9:64-10:8, Fig. 4 (300, 362, 364, 366), 12:58-13:48.

D. “means for determining, based on the derived one or more extracted feature representations, an image property associated with the set of ultrasound images” (Claim 30)

In the California Litigation, Petitioner and Patent Owner have agreed that this term should be construed under 35 U.S.C. §112(f) and that the corresponding structure described in the specification for performing the recited function is: “a processor and memory operating a neural network.” Ex1015, p.2; Ex1001, Fig. 2 (100, 102, 104, 142, 144, 160, 170), 2:11-13, 2:19-23, 6:56-64, 7:50-52, 8:23-9:3, 9:64-10:8, Fig. 4 (300, 372, 374, 376), 13:49-14:53.

E. “means for producing signals representing the quality assessment value and the image property for causing the quality assessment value and the image property to be associated with the set of ultrasound images” (Claim 30)

In the California Litigation, Petitioner and Patent Owner have agreed that this term should be construed under 35 U.S.C. §112(f) and that the corresponding

structure described in the specification for performing the recited function is: “a processor and memory.” Ex1015, p.3; Ex1001, Fig. 2 (100, 102, 104, 140, 150, 152, 170), 7:4-14, 7:50-58, 8:23-9:3, 14:54-15:21.

IX. DETAILED EXPLANATION OF INVALIDITY GROUNDS

A. Summary of the Prior Art

1. US2005/0251013 (“Krishnan”)

Krishnan is a U.S. patent application published on November 10, 2005. Krishnan is prior art to the Patent under 35 U.S.C. §§ 102(a)(1) and 102(a)(2); Ex.1002, ¶¶83-89.

Krishnan is directed to “systems and methods for processing a medical image to automatically identify the anatomy and view (or pose) from the medical image and automatically assess the diagnostic quality of the medical image.” Ex1005, [0002]. In the primary embodiment, the medical image is one or more ultrasound images of the heart, and the identified view can be one of the standard views recognized by the American Society of Echocardiography. Ex1005, [0009], [0019]. “[T]he results of image quality assessment are presented to a user in real-time during image acquisition” so that “the sonographer can determine whether the acquired images are of sufficient diagnostic quality, thereby allowing for changes in image acquisition, if necessary.” Ex1005, [0009].

Referring to Figure 1, reproduced below, Krishnan discloses a system 100 that includes an image feature extraction module 102, an anatomy identification

module 103, a view identification module 104, an image quality assessment module 105, a database 106 of previously diagnosed/labeled medical images, and a classification module 108 with a learning engine 109 and “bank of classifiers” 110 that are used by the various modules 102-105 to perform their respective functions. Ex1005, [0016], [0021], [0023], [0043].

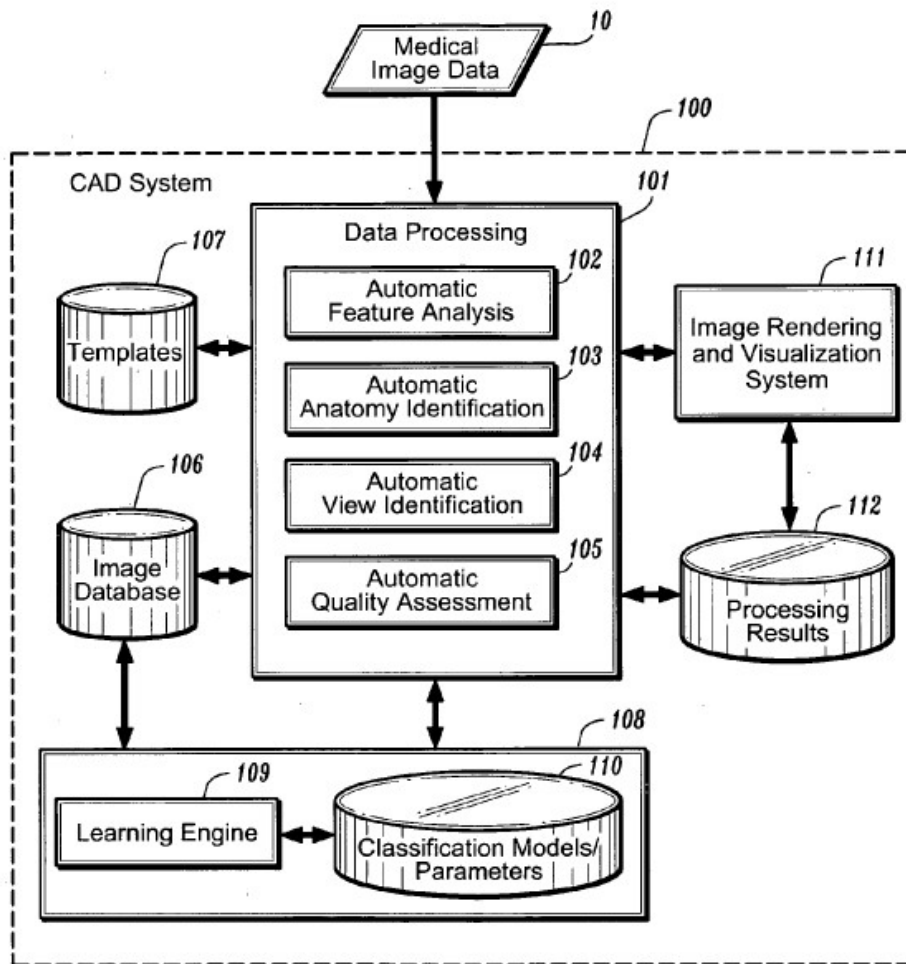

FIG. 1

The system 100 performs the method depicted in Figure 2, reproduced below, including the steps of: (i) obtaining an image dataset including “one or more

medical images” (Ex1005, [0033]); (ii) extracting relevant feature data from the image data set using “known segmentation and/or filtering methods” (Ex1005, [0034]); (iii) using the extracted features to automatically identify the anatomy, view and quality of the image(s) (Ex1005, [0035]); and (iv) labeling the image(s) according to the anatomy, view, and quality assessment results (Ex1005, [0036]).

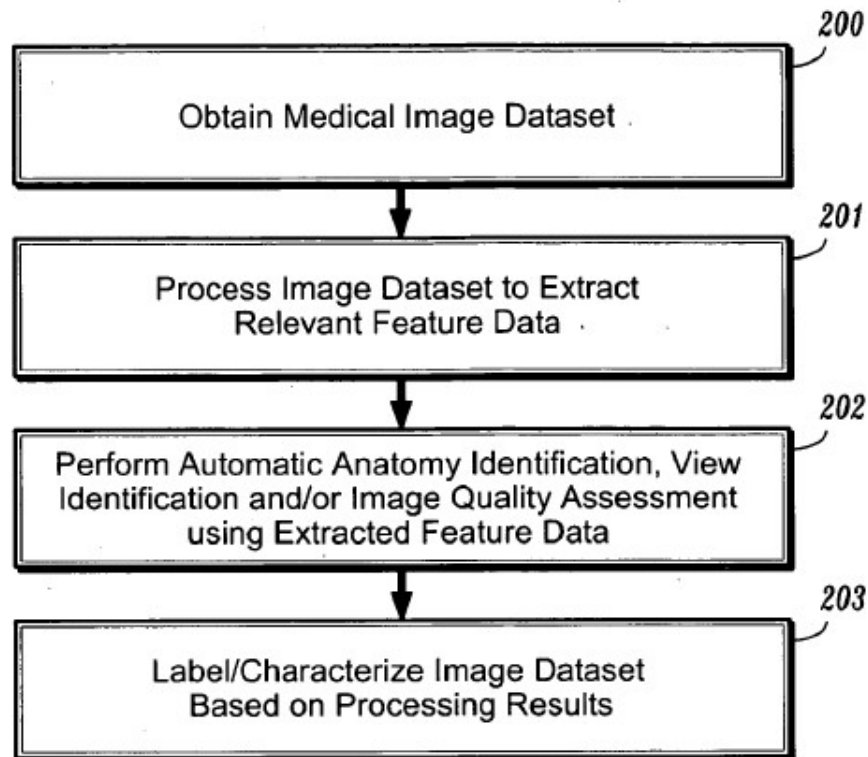

FIG. 2

The image feature extraction module 102 “implements methods for automatically extracting one or more types of features/parameters from input medical image data and combining the extracted features/parameters in a manner that is suitable for processing by [the other modules (e.g., view identification

module 104)].” Ex1005, [0017]. “These features could include any kind of characteristic that could be extracted from the image, such as a particular shape or texture.” Ex1005, [0034]. Additionally, “feature data can be obtained across images, such as motion of a particular point, or the change in a particular feature across images.” *Id.*

The anatomy identification module 103 and view identification module 104 use the extracted “features/parameters” to automatically identify anatomical objects and the view of the acquired image, respectively. Ex1005, [0018]-[0019]. The quality assessment module 105 also “us[es] the extracted features/paraments to assess a level of diagnostic quality of an acquired image data set.” *Id.*, [0020].

According to an exemplary embodiment, the various modules 103-105 shown in Figure 1 perform their respective functions using machine learning. Ex1005, [0023]. For example, the various modules 103-105 may be implemented using one or more trained classifiers that have been built by the learning engine 109 using training data such as previously diagnosed/labeled images from the database 106. *Id.* As explained by Krishnan, “a classifier design can include a multiplicity of classifiers” and can be “neural networks.” Ex1005, [0044]. “These classifiers would use the set of [extracted] features as an input, and classify the image as belonging to a particular anatomy, view, or level of quality.” *Id.*, [0043].

2. US2019/0076127 (“Aase”)

Aase is a U.S. patent application filed on September 12, 2017, and published on March 14, 2019. Ex1006. Aase is prior art to the Patent under 35 U.S.C. §102(a)(2). Ex.1002, ¶¶90-92.

Like Krishnan, Aase is directed to a system and method for analyzing sets of ultrasound images of the heart (“loops”) to automatically assign an image view type and a quality assessment value. Ex1006, Abstract, Fig. 5 (404, 406, 408, 410), [0031]-[0032], [0034], [0035] (“image quality score”), [0043]-[0046]. Aase describes: (a) an “image intake module 150” that “separates [a] continuously captured stream of ultrasound image data into image loops” (*id.*, [0031], [0044]); (b) an “image loop view assignment module 160” that is “operable to automatically assign an image view type” (*id.*, [0032], [0045]); and (c) an “image characteristic metric assignment module 170” that is “operable to assign an image characteristic metric to each image loop” “based on image quality characterizations” (*id.*, [0034], [0046]).

The image loop view assignment module 160 “may apply image detection mechanisms” (*id.*, [0032]) and “may include one or more deep neural networks” made up of multiple layers (*id.*, [0033]). For example, “a first layer may learn to recognize edges of structures in the ultrasound image data” and “a second layer may learn to recognize shapes based on the detected edges from the first layer.”

Id., [0033]. Likewise, the “image characteristic metric assignment module 170 may include one or more deep neural networks ... for scoring the quality of the image loops.” *Id.*, [0035].

3. Automatic Fetal Ultrasound Standard Plane Detection (“Chen”)

Chen is a conference paper from the 18th International Conference on Medical Image Computing and Computer-Assisted Intervention held in Munich, Germany, on October 5-9, 2015. It was published by Springer International Publishing on November 18, 2015, in Medical Image Computing and Computer-Assisted Intervention, MICCAI 2015, Volume 9349, pp.507-514. Ex1009; *see also* Ex1002, ¶¶93-97. Chen is prior art under 35 U.S.C. §102(a)(1).

Chen discloses methods for automatically detecting standard fetal ultrasound planes (*i.e.*, views) from ultrasound videos using trained neural networks. Ex1009, pp.507, 509 (Fig. 2). Specifically, Chen describes the successful use of jointly trained convolutional neural networks (J-CNNs) in combination with recurrent neural networks (RNNs) to accurately identify standard fetal ultrasound views. Ex1009, pp.507, 509. Whereas the J-CNNs extract spatial features from the ultrasound frames (*id.*, pp.508 (“deep learning based spatial feature representations”), 509 (“features ... extracted from the ... CNN model”), Fig 2 (“Spatial features”), 511 (“Features in the penultimate layer ... of the J-CNN model are then extracted from ... each frame.”), the RNN, which is based on an

LSTM model, extracts temporal features based on the extracted features of consecutive images (*id.*, pp.508-509)

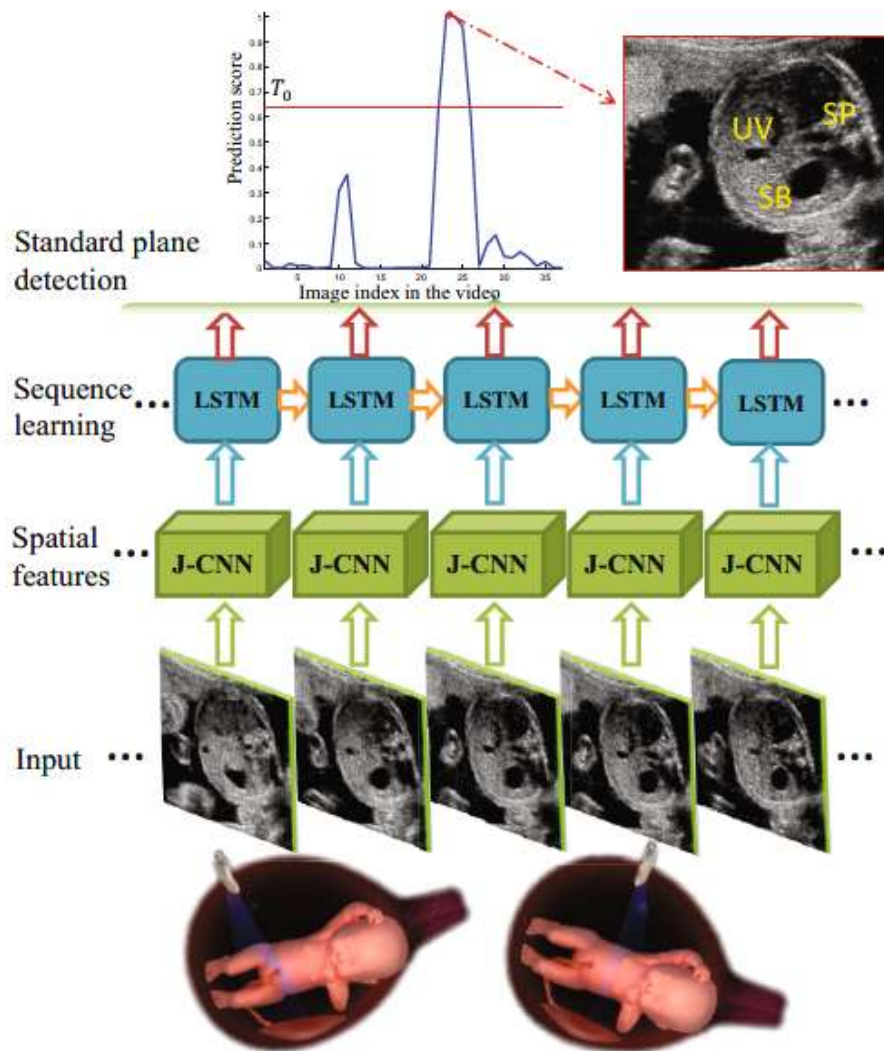

As shown in Figure 2, the left side of which is reproduced above, Chen also depicts *concurrently* inputting a sequence of ultrasound image frames into a plurality of commonly defined J-CNNs to extract spatial features. Ex1009, p.509.

4. Fetal Ultrasound Image Quality Assessment With Deep Convolutional Networks (“Wu”)

Wu is a scientific journal article published in May 2017 by the Institute of Electrical and Electronics Engineers (“IEEE”). Ex1010; Ex.1002, ¶¶98-100. It is prior art under 35 U.S.C. §102(a)(1).

Wu describes techniques for providing an automatic fetal ultrasound image quality assessment (FUIQA). Ex1010, pp.1336-1337 (pdf pp.1-2). Referring to Figure 3, reproduced below, Wu uses a set of ultrasound images as input to a first convolutional neural network (L-CNN), which extracts features from the images by “identifying the region of interest (ROI) of the fetal abdominal region in the US image.” *Id.*, pp.1337 (pdf p.2).

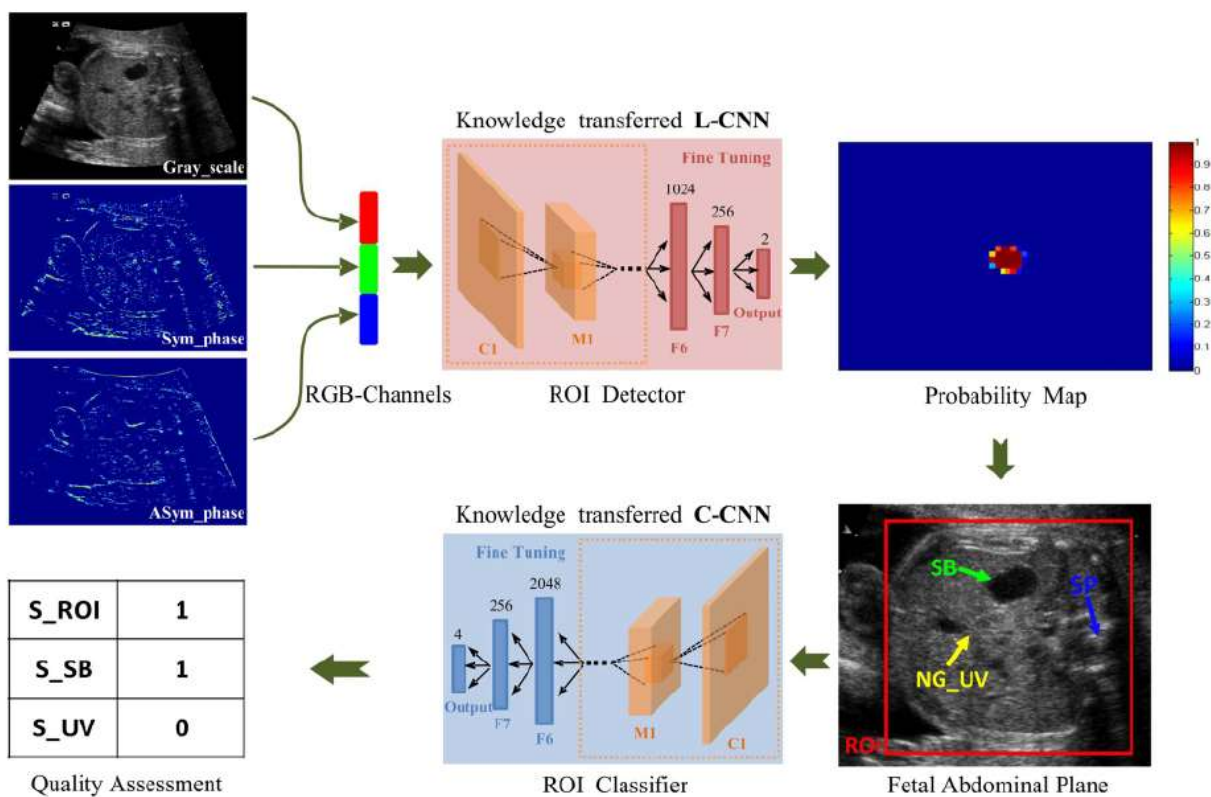

The extracted ROI is then provided as input to a second neural network classifier (C-CNN) that evaluates key features within the ROI and outputs a quality assessment value. *Id.*, pp.1337, 1339 (pdf pp.2,4) (Fig. 3). Although the exemplary embodiment described by Wu relates to the fetal abdominal view/plane, Wu also states that “the proposed FUIQA scheme can be easily generalized to other types of fetal US views for the depiction of fetal face, fetal four cardiac chambers, etc.” *Id.*, p.1338 (pdf p.3).

B. Ground A: Anticipation by Krishnan

1. Claim 1: Method Claim

Claim 1 is anticipated by Krishnan as detailed below, element-by-element.

Ex1002, ¶¶21-22,103-104.

- a) [1(pre)]²: **“A computer-implemented method of facilitating ultrasonic image analysis of a subject, the method comprising:”**

Krishnan discloses the preamble [1(pre)] if it is a limitation. Krishnan is directed to “systems and methods for processing a medical image to automatically identify the anatomy and view (or pose) from the medical image and automatically

² The included Claims Appendix reproduces the full claim language with bracketed reference characters identifying the respective limitations references in this Petition.

assess the diagnostic quality of the medical image.” Ex1005, [0005]. Krishnan states that an “exemplary system (100) comprises a data processing module (101) that implements various methods for analyzing medical image data (10) in one or more image modalities (e.g., ultrasound image data ...) to automatically extract and process relevant information from the medical image data to provide various decision support function(s) for evaluating the medical images.” *Id.*, [0016]. The “methods described may be implemented in various forms of hardware, software, firmware, special purpose processors, or a combination thereof.” *Id.*, [0045]. Thus, Krishnan discloses “a computer-implemented method of facilitating ultrasonic image analysis of a subject,” as claimed. Ex1002, ¶¶105-107.

b) [1(a)]: “receiving signals representing a set of ultrasound images of the subject;”

Krishnan discloses [1(a)]. In Figure 1, reproduced below, the data processing module 101 of system 100 receives “Medical Image Data 10” which Krishnan states may be “ultrasound image data.” Ex1005, [0016]; *see also* [0009] (“ultrasound imaging (e.g., 2-D echocardiography)”). “The system (100) can process digital image data (10) in the form of raw image data, 2-D-reconstructed data (e.g., axial slices), or 3D-reconstructed data.” *Id.*, [0017]; Ex1002, ¶¶108-110.

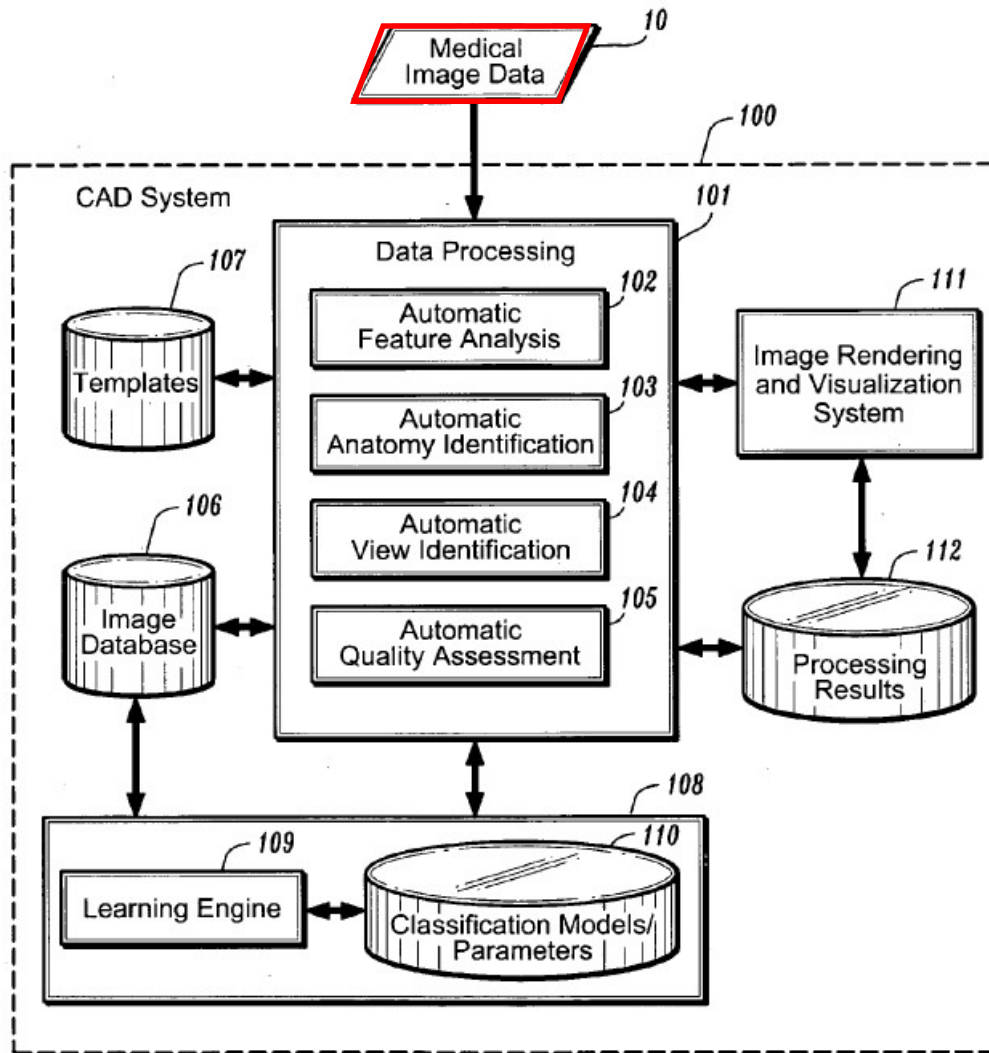

FIG. 1

With reference to Figure 2, reproduced below, Krishnan states: “Initially, a physician, clinician, radiologist, etc., will obtain a medical image dataset comprising one or more medical images of a region of interest of a subject patient (step 200).” Ex1005, [0033].

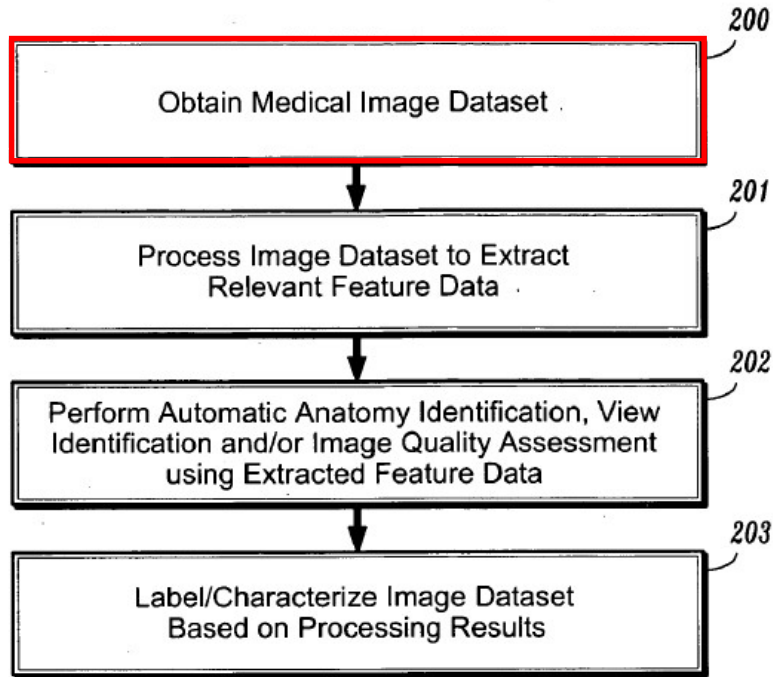

FIG. 2

“The image dataset may be obtained using a medical imaging system for real-time acquisition and processing” or “the image dataset may be obtained by accessing a previously acquired, and persistently stored image dataset.” *Id.* Additionally, “[t]he digital image data (10) may comprise one or more 2D slices,” or “multiple views of a beating heart acquired with a 3D Ultrasound probe.” *Id.*; *see also* [0032] (describing providing automatic quality checks for “loops of data” obtained by a sonographer “where each loop represents a heart cycle.”) Thus, Krishnan discloses “receiving signals representing a set of ultrasound images of the subject,” as claimed.

c) [1(b)]: “deriving one or more extracted feature representations from the set of ultrasound images;”

Krishnan discloses [1(b)]. Figure 1, reproduced again below, depicts a data processing module 101 that includes an “Automatic Feature Analysis” module 102 for extracting feature data from the received medical image dataset 10.

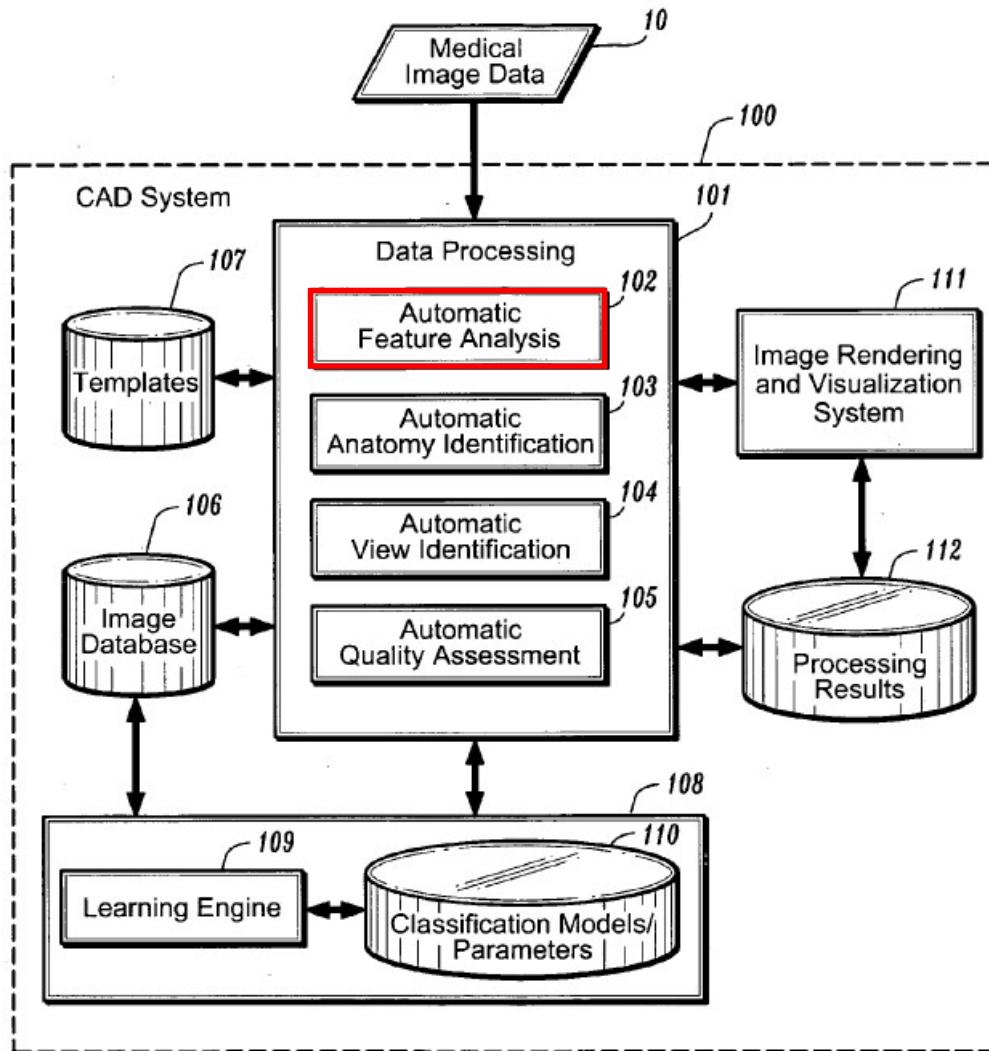

FIG. 1

Krishnan states: “In general, the feature analysis module (102) implements

methods for automatically extracting one or more types of features/parameters from input medical image data and combining the extracted features/parameters in a manner that is suitable for processing by the decision support modules (103, 104 and/or 105).”). *Id.*, [0017]; *see also* [0034] (“feature data may include ... combinations of different features”); Ex1002, ¶¶111-114.

Referring to Figure 2, again reproduced below, Krishnan states: “[T]he image dataset will be processed to ... extract relevant feature data from the image dataset (step 201) which is utilized to perform one or more decision support functions such as automatic anatomy identification, view identification, and/or image quality assessment (step 202).” *Id.*, [0034].

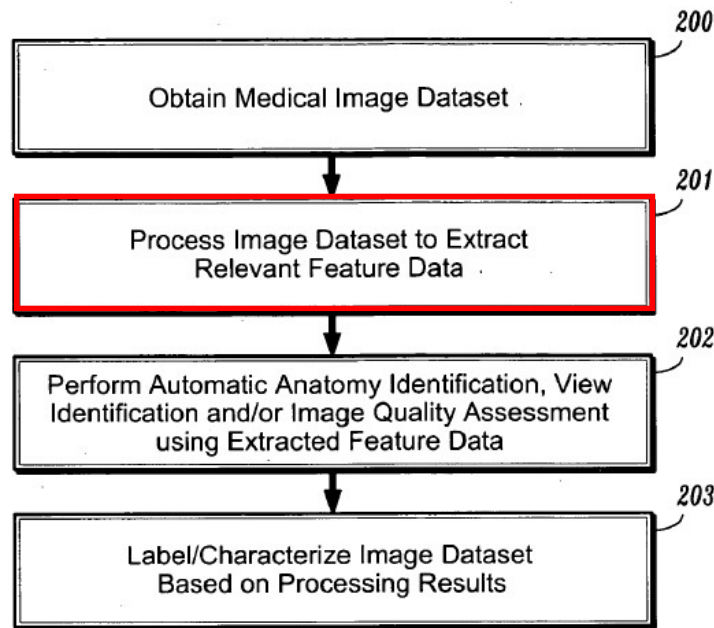

FIG. 2

Krishnan states: “Feature extraction can implement known segmentation and/or

filtering methods for segmenting features or anatomies of interest by reference to known or anticipated image characteristics, such as edges, identifiable structures, boundaries, changes or transitions in colors or intensities, changes or transitions in spectrographic information, etc, using known methods.” *Id.* Additionally, “[t]hese features could include any kind of characteristic that could be extracted from the image, such as a particular shape or texture” and “can be obtained across images, such as motion of a particular point, or the change in a particular feature across images.” *Id.* Thus, Krishnan discloses “deriving one or more extracted feature representations from the set of ultrasound images,” as claimed.

d) [1(c)]: “determining, based on the derived one or more extracted feature representations, a quality assessment value representing a quality assessment of the set of ultrasound images;”

Krishnan discloses [1(c)]. “For example, in one exemplary embodiment, a method for automated decision support for medical imaging includes obtaining image data, extracting feature data from the image data, and automatically ... determining a diagnostic quality of the image data, using the extracted feature data.” Ex1005, [0005], Fig. 2 (202); Ex1002, ¶¶115-119. Referring to Figure 1, below, Krishnan states: “The quality assessment module (105) implements methods for using the extracted features/parameters to assess a level of diagnostic quality of an acquired image data set and determine whether errors occurred in the image acquisition process.” *Id.*, [0020].

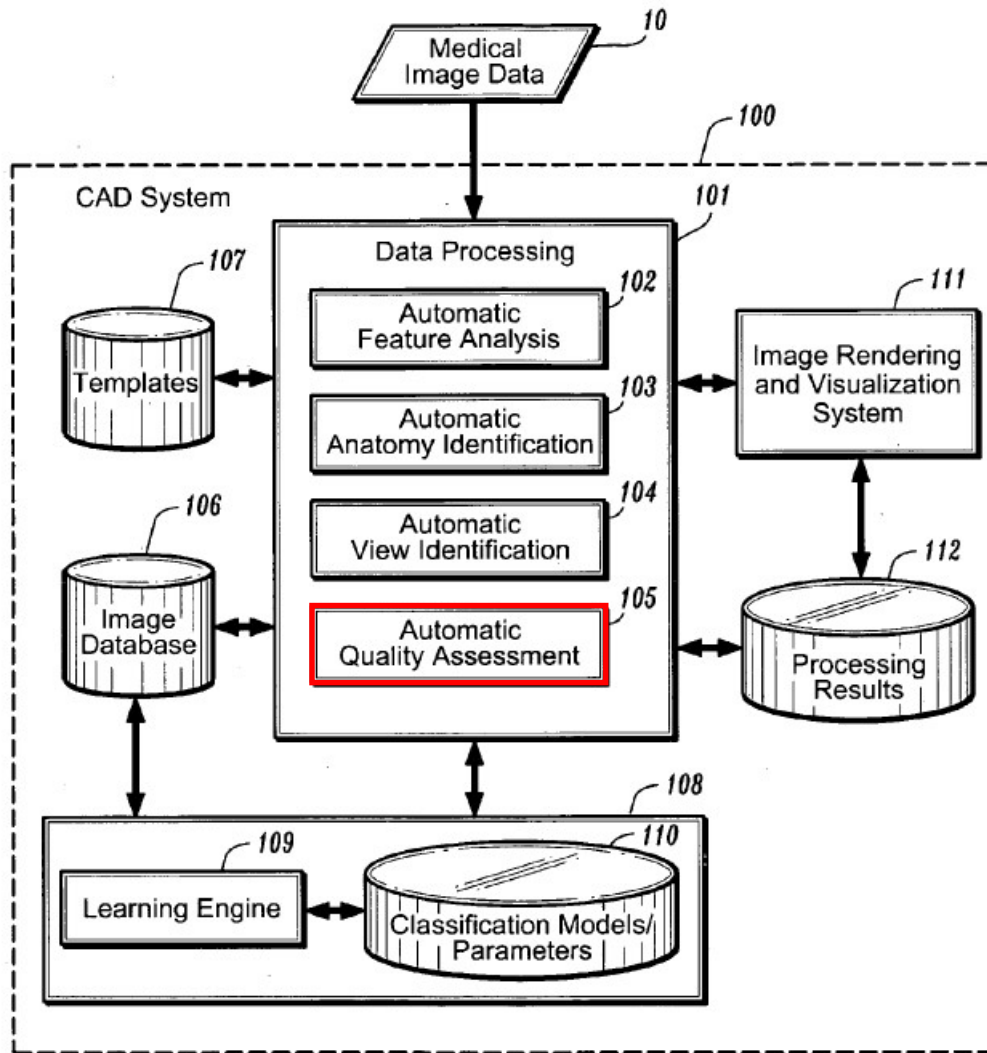

FIG. 1

As explained in Section IX.B.1.b above, the image dataset can include one or more ultrasound images of a subject, including loops of data depicting a beating heart. *See, e.g.*, Ex1005, [0016]-[0017], [0032]-[0033]. For example, Krishnan explains that “with 2-D echocardiography, particularly stress-echo, the sonographer has very limited time to acquire images during a stress stage.” *Id.*,

[0032]. “Often in stress-echo, the sonographer acquires up to four (and sometimes more) loops of data for each view, where each loop represents a heart cycle....”

Id. Krishnan states that “[t]ypically, either the sonographer or cardiologist selects which of the loops provides the best images from a diagnostic standpoint.” *Id.* But, “[b]y providing a quality check, this could be done automatically.” *Id.*

Krishnan states that “methods can be implemented for determining a quality measure within a predefined range of values to provide an indication as [to] the quality level of the acquired images based on some specified criteria.” *Id.* For example, “for image quality assessment, the medical images may include a quality score (within a predetermined range) that provides an indication [of] a diagnostic quality level of the medical images.” *Id.*, [0036]. Thus, Krishnan discloses “determining, based on the derived one or more extracted feature representations, a quality assessment value representing a quality assessment of the set of ultrasound images,” as claimed.

- e) **[1(d)]: “determining, based on the derived one or more extracted feature representations, an image property associated with the set of ultrasound images; and”**

Krishnan discloses [1(d)]. The “image property” recited in the claim can be a “view category” associated with the set of ultrasound images. *See* Ex1001, claim 2, 1:50, 13:49-53 (“the image property may be a view category”). Krishnan states: “[I]n one exemplary embodiment, a method for automated decision support for

medical imaging includes obtaining image data, extracting feature data from the image data, and automatically performing ... view identification ... using the extracted feature data.” Ex1005, [0005]; Ex1002, ¶¶111-114,120-125. As previously described, the image data obtained by Krishnan can be a set of ultrasound images, including “loops of data, where each loop represents a heart cycle.” See Section IX.B.1.b (citing Ex1005, [0016] (“ultrasound image data”), [0032], [0033] (“one or more medical images”) (“image data (10) may comprise one or more 2D slices”).

Krishnan explains: “In stress-echo, the sonographer has very limited time (90 seconds or so for exercise stress) to acquire images from four different views. To save time, the sonographer often just records for a significant portion of the 90 seconds, and then proceed[s] to label the views after imaging is done.” *Id.*, [0028]. Krishnan discloses that “automated view identification methods according to the invention could provide significant workflow enhancement” because “[t]his is a cumbersome process, and could be improved by automatically identifying the views.” *Id.*

Referring to Figure 1, below, Krishnan states: “In the exemplary embodiment, the data processing module (101) comprises ... a view identification module (104)” *Id.*, [0016].

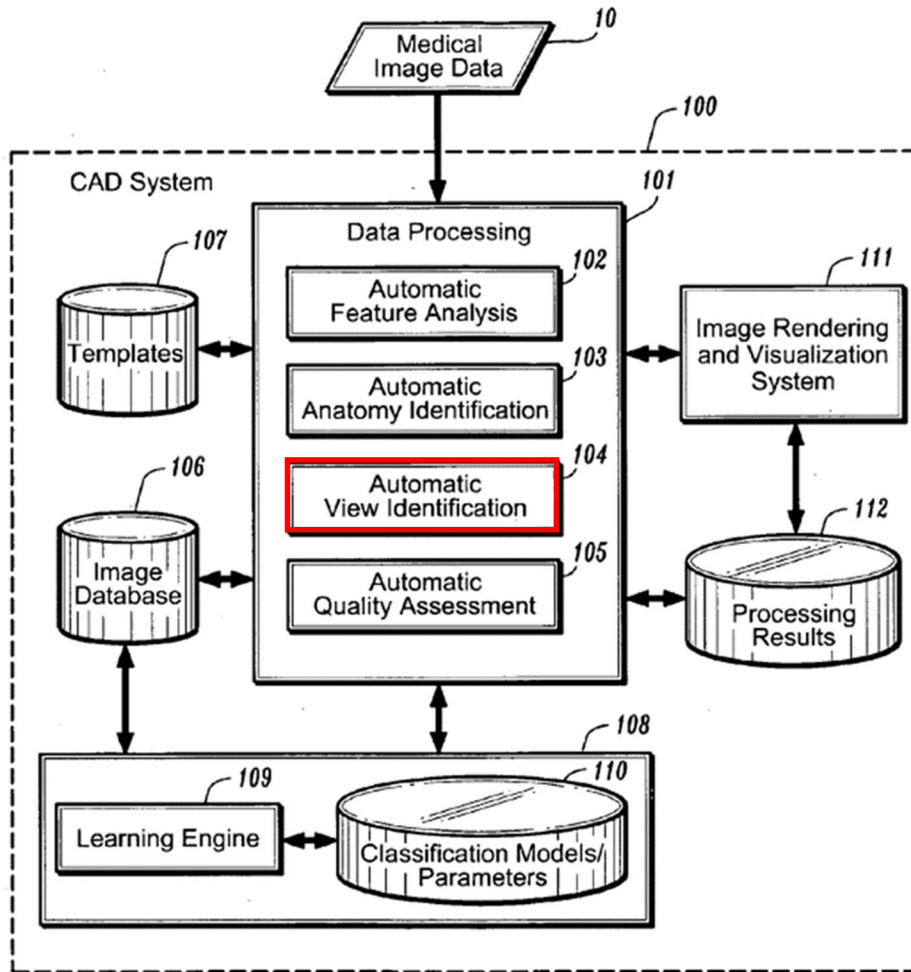

FIG. 1

“The view identification module (103) [sic] implements methods for using the extracted features/parameters to automatically identify the view of an acquired image.” *Id.*, [0019], Fig. 2 (202).

Referring to Figure 5, below, Krishnan states: “In this exemplary embodiment, the feature data extracted from the image dataset would be input to classifiers (step 500) that are trained or designed to process the feature data to

classify the image data (step 501)” for example “to determine the most likely ... view ... (step 502).” Ex1005, [0042].

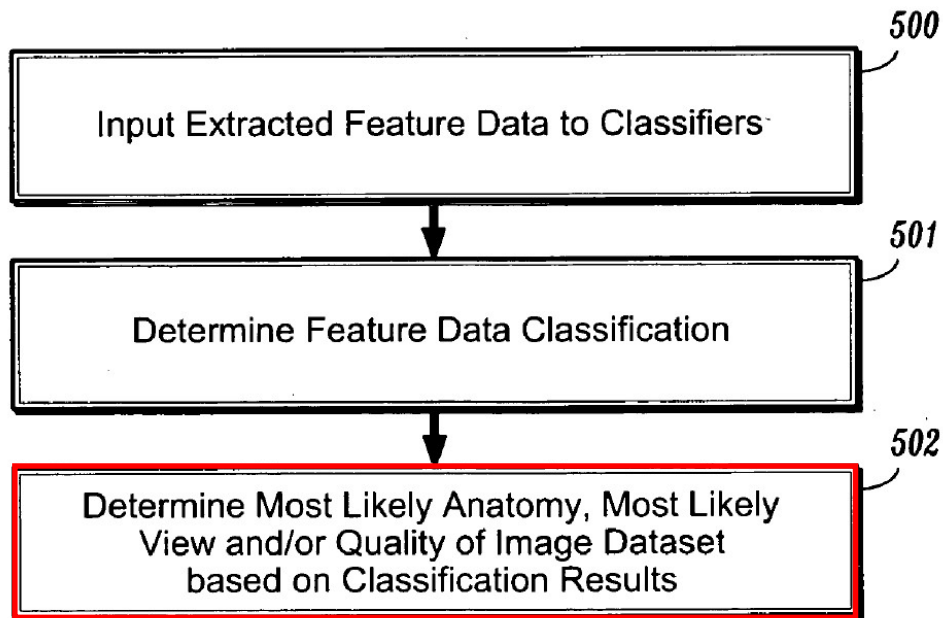

FIG. 5

Id., Fig. 5 (“Determine ... Most Likely View ... of Image Dataset”). Thus, Krishnan discloses “determining, based on the derived one or more extracted feature representations, an image property associated with the set of ultrasound images,” as claimed.

- f) [1(e)]: “producing signals representing the quality assessment value and the image property for causing the quality assessment value and the image property to be associated with the set of ultrasound images.”

Krishnan discloses [1(e)]. In Figure 1, below, Krishnan’s data processing

module 101 includes a view identification module 104 and a quality assessment module 105 for automatically determining a view category and quality assessment value of an image dataset, respectively. *See* Sections IX.B.1.d) and IX.B.1.e).

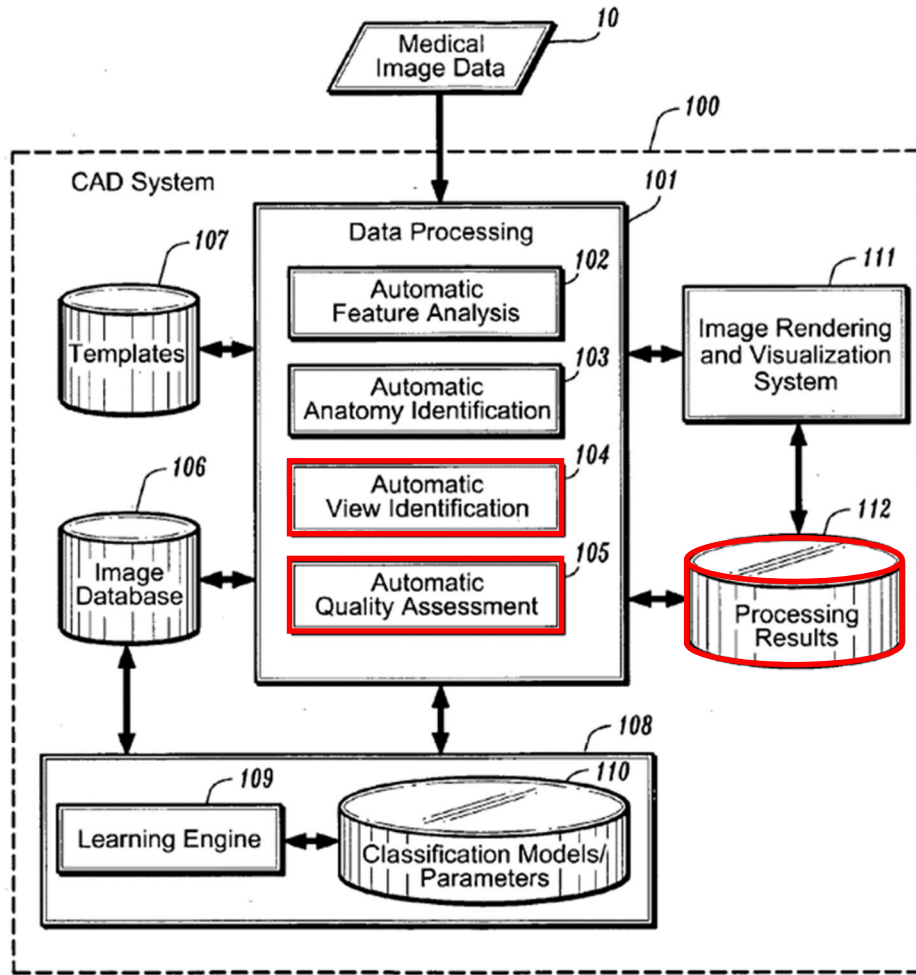

FIG. 1

With respect to view category (i.e., the image property), Krishnan states that “the view identification module (104) implements methods for pose estimation and label[s] a medical image with respect to what view of the anatomy the medical

image contains.” *Id.*, [0019]. With respect to the quality assessment module (105), Krishnan states that “methods can be implemented for determining a quality measure within a predefined range of values to provide an indication as [to] the quality level of the acquired images” and “methods can be implemented for providing real-time feedback during image acquisition regarding the diagnostic quality of the acquired images.” *Id.*, [0020]. Ex1002, ¶¶115-131.

Still referring to Figure 1, above, Krishnan states: “The processing results generated by the various modules of the data processing module (101) [i.e., view and quality assessment score] can be persistently stored in a repository (112) in association with the corresponding image dataset.” Ex1005, [0024]. Additionally, “[t]he processing results ... can be rendered as overlays on the associated image data.” *Id.*

Referring to Figure 2, below, Krishnan states: “The image dataset will be labeled or otherwise classified based on the processing results obtained (step 203). For instance, for ... view identification, a medical image will be labelled with the appropriate ... view identification.” *Id.*, [0036].

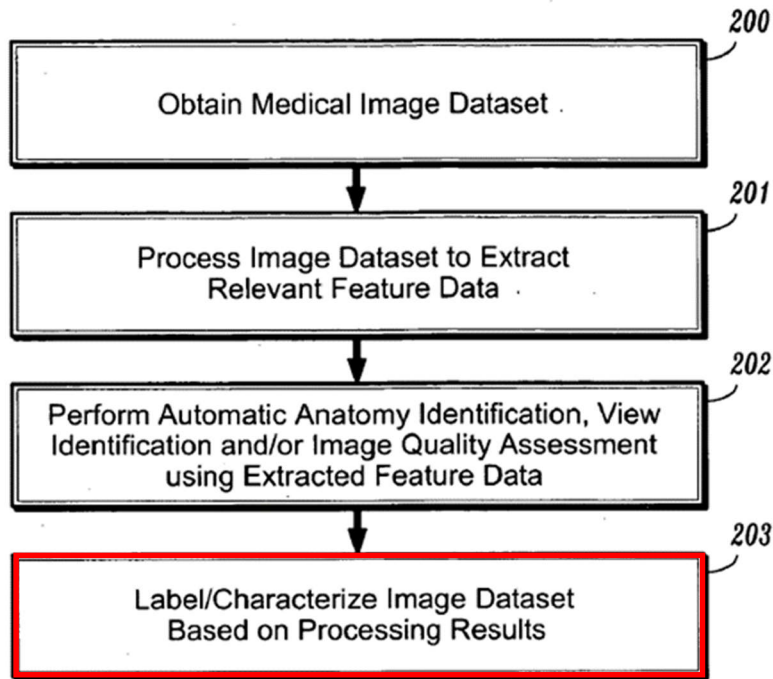

FIG. 2

Additionally, “for image quality assessment, the medical images may include a quality score (within a predefined range) that provides an indication [of] a diagnostic quality of the medical images.” *Id.* Thus, Krishnan discloses “producing signals representing the quality assessment value and the image property for causing the quality assessment value and the image property to be associated with the set of ultrasound images,” as claimed.

Because Krishnan explicitly describes, shows, and discloses every element of claim 1, Krishnan anticipates claim 1.

2. Claim 2: “The method of claim 1, wherein the image property is a view category.”

Claim 2 depends from claim 1, which is anticipated by Krishnan. *See*

Section IX.B.1. As explained in Section IX.B.1.e, above, the image property determined by Krishnan is a view category associated with a set of ultrasound images. Accordingly, Krishnan also anticipates claim 2. Ex1002, ¶¶120-125,132-133.

3. **Claim 3: “The method of claim 2 wherein deriving the one or more extracted feature representations from the ultrasound images comprises, for each of the ultrasound images, deriving a first feature representation associated with the ultrasound image.”**

Claim 3 depends from claim 2, which is anticipated by Krishnan. *See* Section IX.B.1. Krishnan also anticipates claim 3. As already explained in Section IX.B.1.b, above, the medical image dataset obtained by Krishnan can be a set of ultrasound images. As also explained in Section IX.B.1.c, above, “the image dataset will be processed to ... extract relevant feature data from the image dataset” where “[t]hese features could include any kind of characteristic” and “can be obtained across images, such as motion of a particular point, or the change in a particular feature across images.” Ex1005, [0034].

Since Krishnan describes extracting features from a dataset to track the change in a particular feature across multiple images, it discloses deriving a first feature representation for each image within the dataset, as claimed. Ex1002, ¶¶108-114,132-135.

4. **Claim 9: A Quality Assessment Value Specific Neural Network and an Image Property Specific Neural Network**

Claim 9, which is reproduced in full in the Claim Index, depends from claim 2 and adds that the quality assessment value is determined by “inputting the one or more extracted feature representations into a quality assessment value specific neural network,” and the image property is determined by “inputting the one or more extracted feature representations into an image property specific neural network.” Claim 2 is anticipated by Krishnan. Krishnan also anticipates claim 9 because it discloses a “set of classifiers,” which can be neural networks, for performing the described functions of quality assessment and view identification. Ex1002, ¶¶115-119,136-140.

As explained in Section IX.B.1.c above, Krishnan discloses a “feature analysis module (102) ... for automatically extracting one or more types of features/parameters from input medical image data and combining the extracted features/parameters in a manner that is suitable for processing by the decision support modules (103, 104 and/or 105).” Ex1005, [0016]. View identification module 104 “use[s] the extracted features/parameters to automatically identify the view of acquired image.” *Id.*, [0019]. Quality assessment module 105 “use[s] the extracted features/parameters to assess a level of diagnostic quality of an acquired image data set.” *Id.*, [0020].

Krishnan states that “the various modules (103) (104), and (105) can

implement classification methods that utilize [a] classification module (108).” *Id.*, [0023]. The classification module 108 maintains “one or more trained classification models,” also referred to as a “bank of classifiers” or a “set of classifiers” (*id.*, [0043]), which Krishnan states can be “built using neural networks” (*id.*, [0044]). “The classifiers are implemented by the various decision support modules (102-105) for performing their respective functions.” *Id.*, [0023]. For example, “[t]hese classifiers would use the set of features as an input, and classify the image as belonging to a particular anatomy, view, or level of quality.” *Id.*, [0043].

Because Krishnan discloses a bank of neural network classifiers for performing the respective functions of quality assessment and view identification, it discloses the elements of claim 9.

5. Claim 11: Causing to be Displayed

Claim 11, which is reproduced in full in the Claim Index, depends from claim 2 and adds: “producing signals for causing a representation of the quality assessment value and a representation of the image property to be displayed by at least one display in association with the set of ultrasound images.” Krishnan anticipates claim 11 and claim 2 from which it depends. Ex1002, ¶¶141-144.

Referring to Figure 1, Krishnan discloses “an image rendering and visualization system (111) to process digital image data (10) of an acquired image

dataset (or a portion thereof) and generate and display 2D and/or 3D images on a computer monitor.” Ex1005, [0025]. Krishnan states that “[t]he image dataset will be labeled ... based on the processing results obtained.” *Id.*, [0036]. For example, “a medical image will be labeled with the appropriate ... view identification” and “a quality score.” *Id.*; *see also* [0024] (“The processing results ... can be rendered as overlays on the associated image data.”). Additionally, Krishnan states that “automated anatomy identification, view identification, and image quality assessment are performed in real-time during image acquisition, wherein the results of image quality assessment are presented to a user in real-time during image acquisition.” *Id.*, [0009].

Thus, Krishnan discloses, as claimed, producing signals for causing the quality assessment value and image property (i.e., view category) to be displayed in association with a set of ultrasound images.

6. Claim 21: System Claim

Claim 21 is substantially the same as claim 1 except, whereas claim 1 recites a method, claim 21 recites a system comprising a “processor configured to” perform the same steps recited in claim 1. As previously explained, Krishnan discloses a computer-implemented method that anticipates claim 1, where the steps of the method are carried out by a data processor (101). *See* Section IX.B.1. For the same reasons provided above with respect to claim 1, and as cross-referenced

in the table below for convenience, claim 21 is also anticipated by Krishnan. Ex1002, ¶¶103-131,145-162.

Limitation	Reasoning	Krishnan Citations (Ex1005)
[21(pre)]	<i>See</i> Section IX.B.1.a) [1(pre)]	[0016], [0026], [0045]
[21(a)]	<i>See</i> Section IX.B.1.b) [1(a)]	[0016], [0032]-[0033], FIG. 1 (10)
[21(b)]	<i>See</i> Section IX.B.1.b) [1(b)]	[0016]-[0017], FIG. 1 (102)
[21(c)]	<i>See</i> Section IX.B.1.c) [1(c)]	[0016], [0020], [0032], FIG. 1 (105)
[21(d)]	<i>See</i> Section IX.B.1.d) [1(d)]	[0005], [0016], [0019], FIG. 1 (104)
[21(e)]	<i>See</i> Section IX.B.1.e)) [1(e)]	[0019]-[0020], [0024], [0036]

7. Claim 22: “The system of claim 21 wherein the image property is a view category.”

Claim 22 is anticipated by Krishnan for the same reasons already explained with respect to claim 21 (Section IX.B.6) and claim 2 (Section IX.B.2). Ex1002, ¶¶115-119,136-140,163-164.

8. Claim 27: A Quality Assessment Value Specific Neural Network and an Image Property Specific Neural Network

Claim 27 is substantially the same as claim 9 except, whereas claim 9 is a method claim, claim 27 is a system claim that depends from claim 22 and recites “wherein the at least one processor is configured to” perform the same functions recited in claim 9. Krishnan anticipates claim 22 for the reasons addressed immediately above. Additionally, Krishnan discloses a computer-implemented system that performs the functions recited in claim 27 for the same reasons already discussed with respect to claim 9. Ex1002, ¶¶115-119,136-140,165-170; *See* Section IX.B.4. With reference to Figure 1, reproduced below, Krishnan’s “data

processing” module/system 101 (Ex1005, [0016], [0026]) is a processor, as claimed, that implements a view identification module 104 and a quality assessment module 105. Thus, Krishnan also discloses at least one processor configured to perform the functions recited in claim 27 rendering claim 27 anticipated.

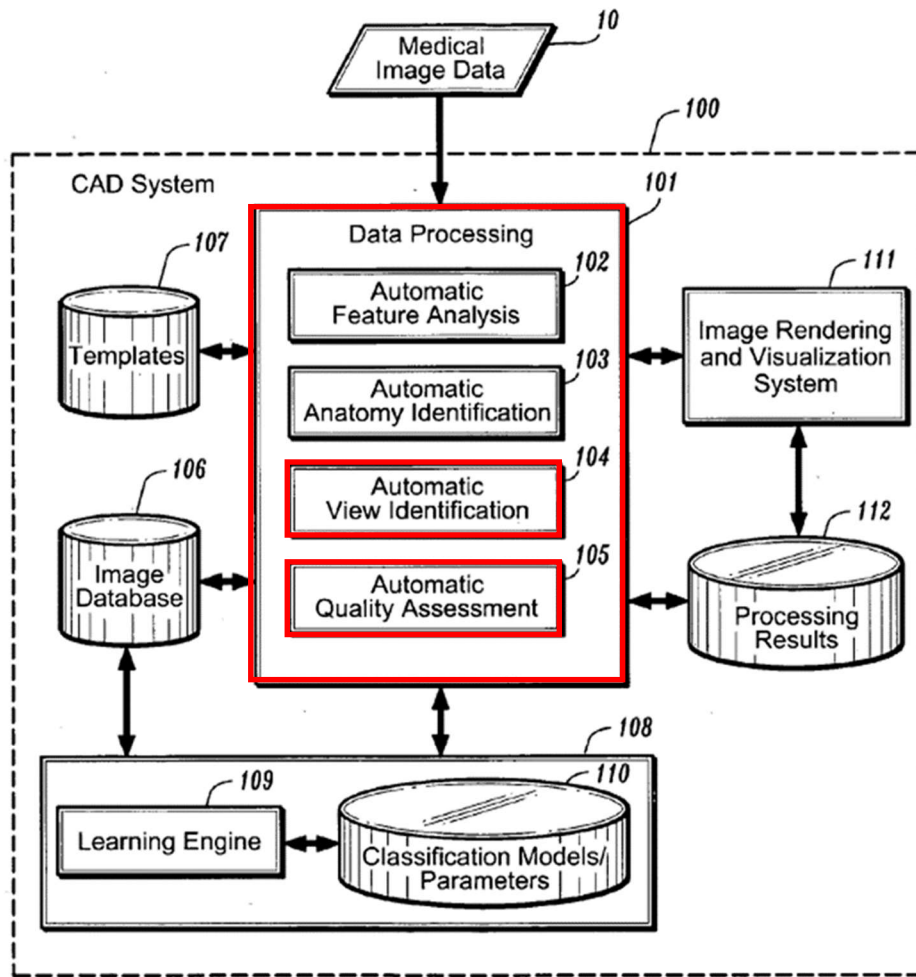

FIG. 1

9. Claim 29: Causing to be Displayed

Claim 29 is substantially the same as claim 11 except, whereas claim 11 is a method claim, claim 29 is a system claim that depends from claim 22 and recites “wherein the at least one processor is configured to” perform the same function recited in claim 11. Krishnan anticipates claim 22 for the reasons already addressed above. Additionally, Krishnan discloses the functions recited in claim 29 for the same reasons already discussed with respect to claim 11. *See* Section IX.B.5; Ex1002, ¶¶141-144,171-176. As addressed immediately above with respect to claim 27, Krishnan’s data processing module/system 101 is a processor, as claimed. Krishnan states that “[t]he data processing system (101) and image rendering and visualization system (111) may be implemented as a single application” or alternatively “may be independent tools that are distributed over a computer network” for “transmitting image data over the network.” Ex1005, [0026]. Thus, Krishnan also discloses at least one processor configured to perform the functions recited in claim 29 rendering claim 29 anticipated.

10. Claim 30: Means-Plus-Function Claim

Claim 30 is substantially identical to claim 21 except, whereas claim 21 is a system claim comprising “at least one processor configured to” perform a series of functions, claim 30 is a system claim drafted in means-plus-function format comprising a series of “means for” performing the same functions recited in claim

21. As previously explained, claim 21 is anticipated by Krishnan. *See* Section IX.B.6. Claim 30, when properly construed, is also anticipated by Krishnan. Ex1002, ¶¶145-162.

a) “[30(pre)]

[30(pre)] is identical to [21(pre)] except that it does not recite “at least one processor configured to.” Accordingly, Krishnan discloses [30(pre)] for the same reasons already provided for [21(pre)]. *See* Section IX.B.6; Ex1002, ¶¶146-147,178.

b) [30(a)]

[30(a)] is drafted in means-plus-function format and recites the same function as [21(a)]. For the reasons already provided with respect to [21(a)], Krishnan performs the function recited in [30(a)]. *See* Section IX.B.6; Ex1002, ¶¶148-150,179-183.

The corresponding structure disclosed in the Patent for performing the claimed function is simply a processor with an I/O (i.e., input/output) interface. *See* Section VIII.A. Only the input aspect of the I/O interface, however, is required to perform the recited function of “receiving” signals. Krishnan discloses this structure for performing the recited function. Ex1005, [0025]-[0026], Fig. 1 (10, 101, 111), [0017] (“from input medical image data”).

As previously explained, Krishnan’s data processing module/system 101

corresponds to a processor and it receives a set of one or more ultrasound images as input. *See, e.g.*, Section IX.B.1.b. Krishnan explains that the ultrasound image dataset received by the data processing module/system 101 can be received in real-time from a medical imaging system or be “obtained by accessing a previously acquired, and persistently stored image dataset.” Ex1005, [0033]. As depicted in Figure 1, below, the processor (101) has one or more input/output interfaces (not labeled) for receiving/outputting/exchanging data with, for example, a visualization system 111, an image database 106, and a repository 112 for processed results. *Id.*, [0024]-[0025].

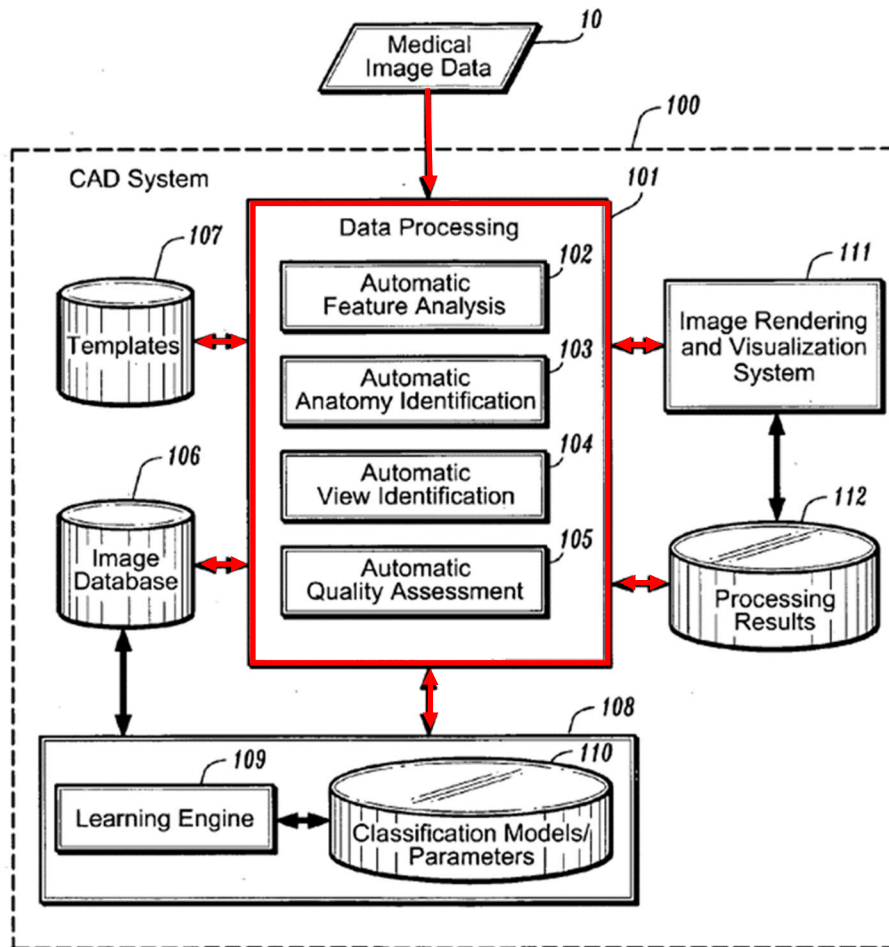

FIG. 1

Additionally, Krishnan explains that the “data processing [module/] system (101)” may be part of a “computer network, wherein known communications protocols such as DICOM, PACs, etc. are used for communicating between the systems and transmitting image data over the network.” Ex1005, [0026].

Thus, Krishnan discloses [30(a)] because it discloses a processor with an input/output interface that performs the recited function of receiving signals representing a set of ultrasound images.

c) [30(b)]

[30(b)] is drafted in means-plus-function format and recites the same function as [21(b)]. For the reasons already provided with respect to [21(b)], Krishnan performs the function recited in [30(b)]. *See* Section IX.B.6.c); Ex1002, ¶¶151-152,184-188.

The corresponding structure/algorithm disclosed in the Patent for performing the claimed function is a processor and memory operating a neural network. *See* Section VIII.B. Krishnan discloses this structure/algorithm for performing the recited function.

Krishnan discloses a data processing module/system 101 that corresponds to a processor and includes a feature analysis module 102 that extracts features/parameters from a set of input ultrasound images 10 using known techniques such as segmentation and/or filtering. *See* Section IX.B.6.c). With reference to Figure 1, below, Krishnan also discloses a classification module/system 108 with a knowledge base 110 corresponding to a memory that “maintains one or more trained classification models” (i.e., “classifiers”). Ex1005, [0021], [0023], [0043]. Krishnan states that “[t]he classifiers are implemented by the various decision support modules (102-105) for performing their respective functions.” *Id.*, [0023]; *see also* [0021] (“[C]lassification system (108) ... can be used ... by one or more of the various automated decision support modules (102-

105) of the data processing system (101) to perform their respective functions.”).

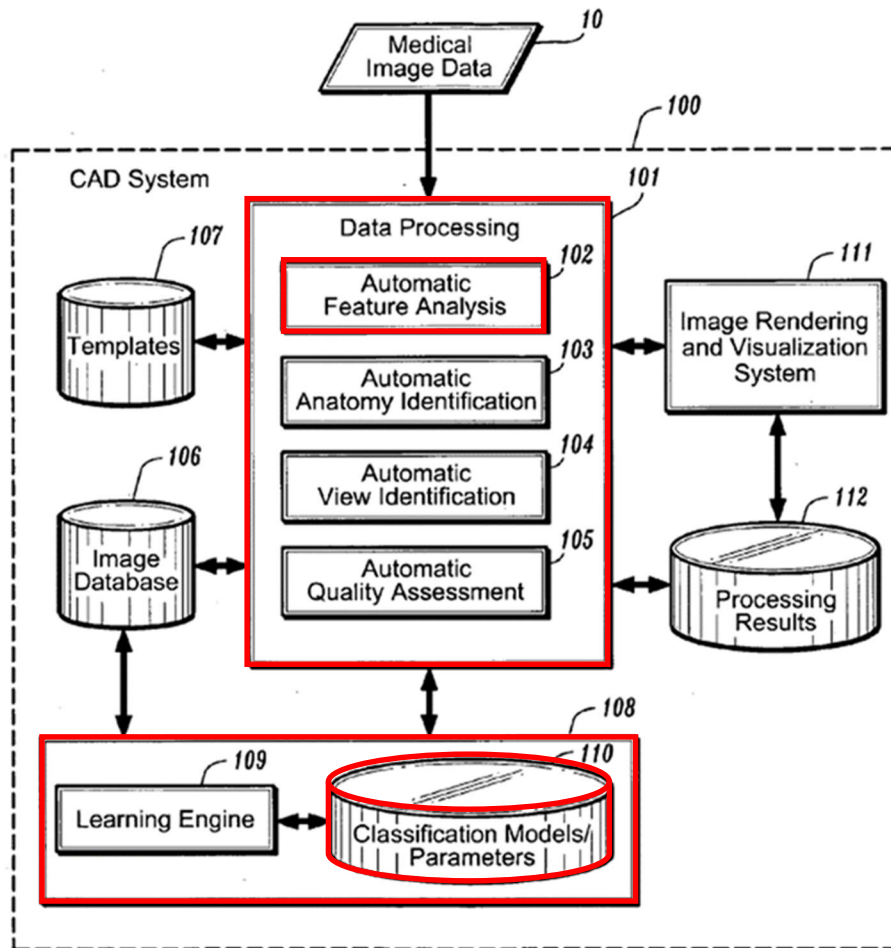

FIG. 1

Krishnan also states that the classifiers can be “built using neural networks.” *Id.* [0044]. Indeed, the use of artificial neural networks to perform feature extraction tasks, including, for example, segmentation or identification objects in medical images was well-known prior to the priority date of the Patent. *See, e.g.*, Ex1007 (Angelova), 4:10-15 (“the feature extraction layers may include one or more convolutional neural network (CNN) layers”); Ex1014, p.267 (Kong) (“we employ

a CNN as the feature extractor”).

Thus, Krishnan discloses [30(a)] because Krishnan discloses a processor (101, 102) and memory (110) operating a neural network (classifier) to, as claimed, derive extracted feature representations of a set of ultrasound images.

d) [30(c)]

[30(c)] is drafted in means-plus-function format and recites the same function as [21(c)]. For the reasons already provided with respect to [21(c)], Krishnan performs the function recited in [30(c)]. *See* Section IX.B.6.d); Ex1002, ¶¶153-154,189-192.

The corresponding structure/algorithm disclosed in the Patent for performing the claimed function is a processor and memory operating a neural network. *See* Section VIII.C. Krishnan discloses the same structure/algorithm for performing the recited function.

As previously explained with respect to [21(c)] above, Krishnan discloses a data processing module/system 101 that corresponds to a processor and includes a quality assessment module 105 that determines a quality assessment value for a set of input ultrasound images. *See* Section IX.B.6.d (citing Ex1005, [0020] (“assess a level of diagnostic quality of an acquired image data set”). As explained in Section IX.B.8.c immediately above, Krishnan also discloses a classification module/system 108 with a knowledge base 110 corresponding to a memory that

“maintains one or more trained classification models” (i.e., “classifiers”). Ex1005, [0021], [0023], [0043]. Krishnan states that “[t]he classifiers are implemented by the various decision support modules (102-105) for performing their respective functions.” *Id.*, [0023]; *see also* [0021] (“[C]lassification system (108) ... can be used ... by one or more of the various automated decision support modules (102-105) of the data processing system (101) to perform their respective functions.”). Krishnan also states that the classifiers can be “built using neural networks” (*id.* [0044]) and “[t]hese classifiers would use the set of features as an input, and classify the image[s] as belonging to a particular ... level of quality” (*id.*, [0043]).

Thus, Krishnan disclosed [30(c)] because it discloses a processor (101, 105) and memory (110) operating a neural network (classifier) to, as claimed, determine, based on the derived one or more extracted feature representations, a quality assessment value for the set of ultrasound images.

e) [30(d)]

[30(d)] is drafted in means-plus-function format and recites the same function as [21(d)]. For the reasons already provided with respect to [21(d)], Krishnan performs the function recited in [30(d)]. *See* Section IX.B.6.e); Ex1002, ¶¶155-58,193-196.

The corresponding structure/algorithm disclosed in the Patent for performing the claimed function is a processor and memory operating a neural network. *See*

Section VIII.D. Krishnan discloses the same structure/algorithm for performing the recited function.

Krishnan discloses a data processing module/system 101 that corresponds to a processor and includes a view identification module 104 that determines a view category associated with a set of input ultrasound images. *See* Section IX.B.6.e). As explained in Section IX.B.8.c) above, Krishnan also discloses a classification module/system 108 with a knowledge base 110 corresponding to a memory that “maintains one or more trained classification models” (i.e., “classifiers”). Ex1005, [0021], [0023], [0043]. Krishnan states that “[t]he classifiers are implemented by the various decision support modules (102-105) for performing their respective functions.” *Id.*, [0023]; *see also* [0021] (“[C]lassification system (108) ... can be used ... by one or more of the various automated decision support modules (102-105) of the data processing system (101) to perform their respective functions.”). Krishnan also states that the classifiers can be “built using neural networks” (*id.* [0044]) and “[t]hese classifiers would use the set of features as an input, and classify the image[s] as belonging to a particular ... view” (*id.*, [0043]).

Thus, Krishnan disclosed [30(d)] because it discloses a processor (101, 104) and memory (110) operating a neural network (classifier) to, as claimed, determine, based on the derived one or more extracted feature representations, an image property (i.e., view category) associated with the set of ultrasound images.

f) [30(e)]

[30(e)] is drafted in means-plus-function format and recites the same function as [21(e)]. For the reasons already provided with respect to [21(e)], Krishnan performs the function recited in [30(e)]. *See* Section IX.B.6.f); Ex1002, ¶¶159-162,197-201.

The corresponding structure disclosed in the Patent for performing the claimed function is simply a processor and memory. *See* Section VIII.E. Krishnan discloses the same structure for performing the recited function.

Krishnan discloses a data processing module/system 101 that corresponds to processor and includes a view identification module 104 and an image quality assessment module 105 for producing signals representing the view category and quality assessment value of a set of ultrasound images, respectively. Ex1005, [0019], [0036]. Krishnan also states: “The processing results generated by the various modules of the data processing module (101) [i.e., view and quality assessment score] can be persistently stored in a repository (112) in association with the corresponding image dataset.” Ex1005, [0024]. The repository 112 corresponds to a memory where the view and quality value are associated with the ultrasound images.

Thus, Krishnan disclosed [30(e)] because it discloses a processor (101, 104, 105) and memory (112) that perform the recited function, as claimed.

C. Ground B: Obviousness over Krishnan in view of Chen

1. Claim 3

Krishnan anticipates claim 3. Additionally, or alternatively, Krishnan-Chen (Ex1009) renders claim 3 unpatentable as obvious. Ex1002, ¶¶23-32,103-104,108-114,132-135.

Claim 3 depends from claim 2, which in turn depends from claim 1. Krishnan anticipates claim 1 (Section IX.B.1) and claim 2 (Section IX.B.2). Claim 3 adds: “for each of the ultrasound images, deriving a first feature representation associated with the ultrasound image.”

Chen discloses [3]: Chen presents “a general framework to detect standard planes [(i.e., views)] from US [(ultrasound)] videos automatically.” Ex1009, Abstract. Referring to Figure 2, the left side of which is reproduced below, Chen discloses a neural network architecture comprising “a hybrid model integrating deep convolutional neural networks (CNN) and recurrent neural networks (LSTM model)” that “considers spatio-temporal feature representations ... for the detection of standard planes from US videos.” Ex1009, p.509.

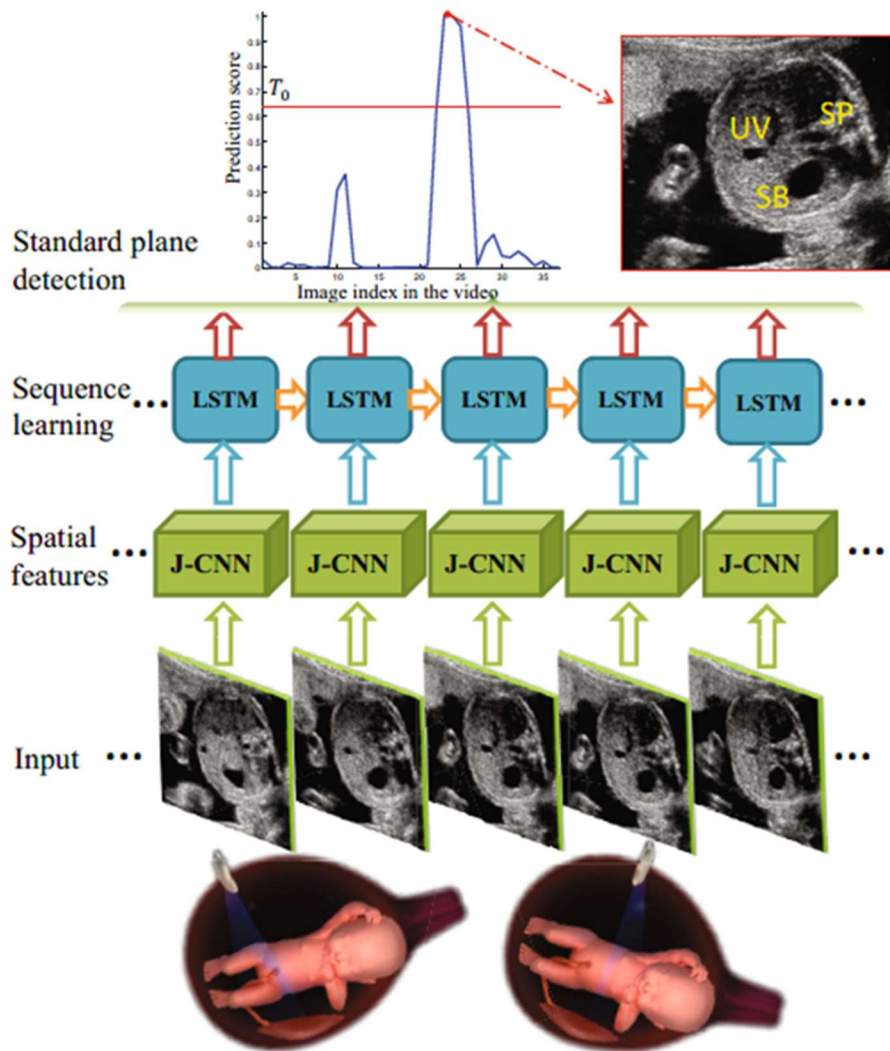

Still referring to Figure 2, above, Chen explains that a “classifier is first trained based on ... convolutional neural networks (J-CNN) ... to locate the most discriminative regions for US standard plane detection” (Ex1009, p.509) and “[f]eatures in the penultimate layer ... of the J-CNN model are then extracted from ... each frame” (*id.*, 511). “Then, the temporal information is explored via the LSTM model based on the features ... in consecutive frames extracted from the

J-CNN model.” *Id.* A POSITA would understand that the figure above depicts the sequential frames of an ultrasound video being input into respective J-CNNs to extract spatial feature representations from each frame before the extracted features are analyzed by the temporal sequence learning model (LSTMs). Ex.1002, ¶¶203-205.

Thus, Chen discloses, as claimed in claim 3, “wherein deriving the one or more extracted feature representations from the ultrasound images comprises, for each of the ultrasound images, deriving a first feature representation associated with the ultrasound image.” *Id.*

Rationale to combine: A POSITA would have been motivated to combine Krishnan and Chen based on the express teachings within the references. Krishnan and Chen are in the same field of art, *i.e.*, analysis of ultrasound images/videos using machine learning to automatically determine a view category. Whereas Krishnan generally discloses extracting feature data from a sequential set of ultrasound images to, for example, observe “the change in a particular feature across images” (Ex1005, [0034]), Chen discloses a sample recurrent neural network architecture (T-RNN) for extracting feature data from a sequential set of ultrasound images. Additionally, Chen supplies the motivation to use its neural network architecture, stating “[t]emporal information in time-series videos could provide additional contextual clues for the improvement of detection performance”

(Ex1009, p.511) and “[c]ompared with other methods, our T-RNN achieved the best performance ..., which further highlighted the superiority of exploring spatio-temporal feature learning ... in standard plane detection from US videos” (*id.*, p.513). Therefore, it would have been natural and obvious to a POSITA to combine the teachings of Krishnan and Chen by using the neural network architecture disclosed in Chen to perform feature extraction as described in Krishnan. Ex1002, ¶¶206-207.

Alternatively, combining Krishnan and Chen as proposed would merely have amounted to using a known technique to improve similar devices (“Chen I” and Krishnan) in the same way. Chen represents an improvement over an earlier publication, Chen I. Specifically, Chen describes Chen I as using convolutional neural networks to detect the fetal abdominal standard plane (i.e., view) in ultrasound images but states that “only considering spatial features may not be the optimal solution, since temporal information of consecutive sequences in US videos could provide extra contextual clues for better discrimination.” Ex1009, p.508. Thus, as already explained, Chen teaches the improvement of extracting features from consecutive frames of ultrasound videos and using recurrent neural networks to consider “spatio-temporal feature representations ... for the detection of standard planes[.]” *Id.*, pp.509-511.

Krishnan, like Chen I, is also directed to the use of neural networks to

identify the view category of ultrasound images. *See, e.g.*, Section IX.B.10.e). Additionally, as already stated, Krishnan is capable of processing one or more ultrasound images, including loops of data (i.e., videos). Therefore, it would have been obvious to a POSITA to improve Krishnan with Chen in the same way that Chen improves Chen I, *i.e.*, by extracting features from consecutive images in a set, rather than a single image, to leverage temporal information for better view identification. Ex1002, ¶208

Reasonable expectation of success: A POSITA would also have had a reasonable expectation of success combining Chen with Krishnan. Krishnan already contemplates using a “bank of classifiers” that perform respective functions. Implementing Chen with Krishnan would merely have involved adding the neural network classifier described in Chen, without modification, to the bank of classifiers described in Krishnan. Ex1002, ¶209.

Krishnan describes using a “bank of classifiers” (Ex1005, [0043]), which Krishnan states can be “built using neural networks” (*id.*, [0044]), where “[t]he classifiers are implemented by the various decision support modules (102-105) for performing their respective functions” (*id.*, [0023]). Two of those functions are feature extraction and view identification. The neural network disclosed in Chen performs the same functions and utilizes the same type of ultrasound data obtained by Krishnan, *i.e.*, multiple ultrasound images (“loops of data”). *Id.* Additionally,

Chen explicitly states that “the proposed T-RNN is a general framework and can be easily extended to other US standard plane or anatomical structure detection problems.” Ex1009, p.509, 514.

Thus, a POSITA would have been motivated to combine, and would have had a reasonable expectation of success combining, Krishnan and Chen to arrive at subject matter claimed in claim 3. Ex1002, ¶210.

2. **Claim 4: “The method of claim 3 wherein deriving the one or more extracted feature representations comprises, for each of the ultrasound images, inputting the ultrasound image into a commonly defined first feature extracting neural subnetwork to generate the first feature representation associated with the ultrasound image.”**

Claim 4 depends from claim 3, which is anticipated by Krishnan (Section IX.B.3) and/or rendered obvious by Krishnan-Chen (Section IX.C.1). Claim 4 is rendered obvious by Krishnan-Chen because Chen discloses the elements of claim 4 and it would have been obvious to combine Chen with Krishnan for the same reasons expressed in Section IX.C.1 above. Ex1002, ¶¶206-216.

Chen discloses [4]: Referring to the figure below, Chen states: “Fig. 2 (left) shows the architecture of the proposed T-RNN [(knowledge transferred recurrent neural network)], which is a hybrid model integrating deep convolutional neural networks (CNN) and recurrent neural networks (LSTM model).” Ex1009, p.509. For avoidance of confusion, the multiple CNNs referred to in the passage above are each labeled “J-CNN” in the figure, which stands for “joint learning”

convolutional neural networks. *Id.*

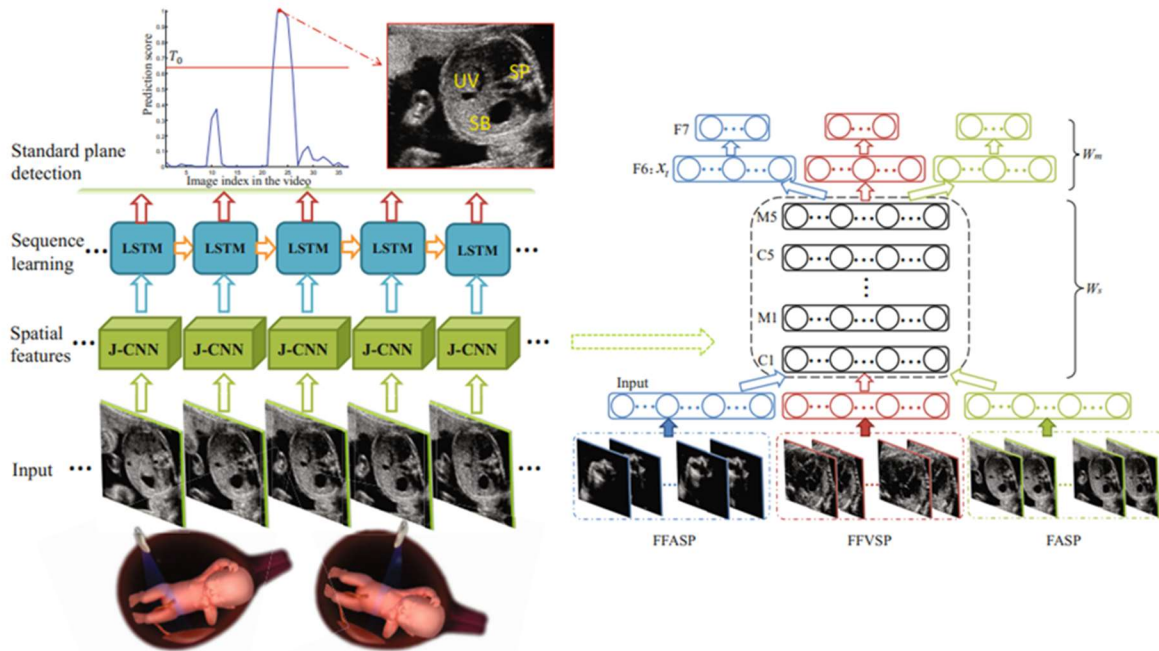

Fig. 2. Left: architecture of the proposed T-RNN; right: the proposed J-CNN.

As shown above, Chen extracts features from a set of ultrasound images by first inputting each consecutive frame of an ultrasound video into a respective J-CNN that extracts spatial features from the frame. Each J-CNN is a sub-network, as claimed, within the overall T-RNN network. Additionally, with reference to the right side of Figure 2, each J-CNN is commonly defined, as claimed. Ex1009, p.509 (“Fig. 2 Left: architecture of the proposed T-RNN; right: the proposed J-CNN”). Accordingly, Chen discloses the elements of claim 4. Ex1002, ¶¶212-213.

Rationale to combine: A POSITA would be motivated to combine Krishnan-Chen in the manner proposed (*i.e.*, to use the T-RNN model disclosed in Chen to perform feature extraction and view identification as taught in Krishnan)

for the same reasons already explained in Section IX.C.1 above. Ex1002, ¶214.

Reasonable expectation of success: A POSITA would have had a reasonable expectation of success in combining Krishnan-Chen to achieve the claimed subject matter for the same reasons already explained in Section IX.C.1 above. Chen is an enabling disclosure that would allow a POSITA to practice the described techniques without undue experimentation. Ex1002, ¶215. And, merely adding Chen’s T-RNN to Krishnan’s “bank of classifiers” to perform the same functions already described in Krishnan, would not require any modification of Krishnan or Chen. Ex1002, ¶216.

3. **Claim 5: “The method of claim 4 wherein deriving the one or more extracted feature representations comprises concurrently inputting each of a plurality of the ultrasound images into a respective implementation of the commonly defined first feature extracting neural network.”**

Claim 5 depends from claim 4, which is rendered obvious by Krishnan-Chen. Chen also discloses the features of claim 5, thus rendering claim 5 obvious for the same reasons provided in Section IX.C.2; Ex1002, ¶¶206-209,214-215,217-220.

The J-CNNs in Figure 2, below, are feature extracting neural networks that extract spatial features from each frame of an ultrasound video.

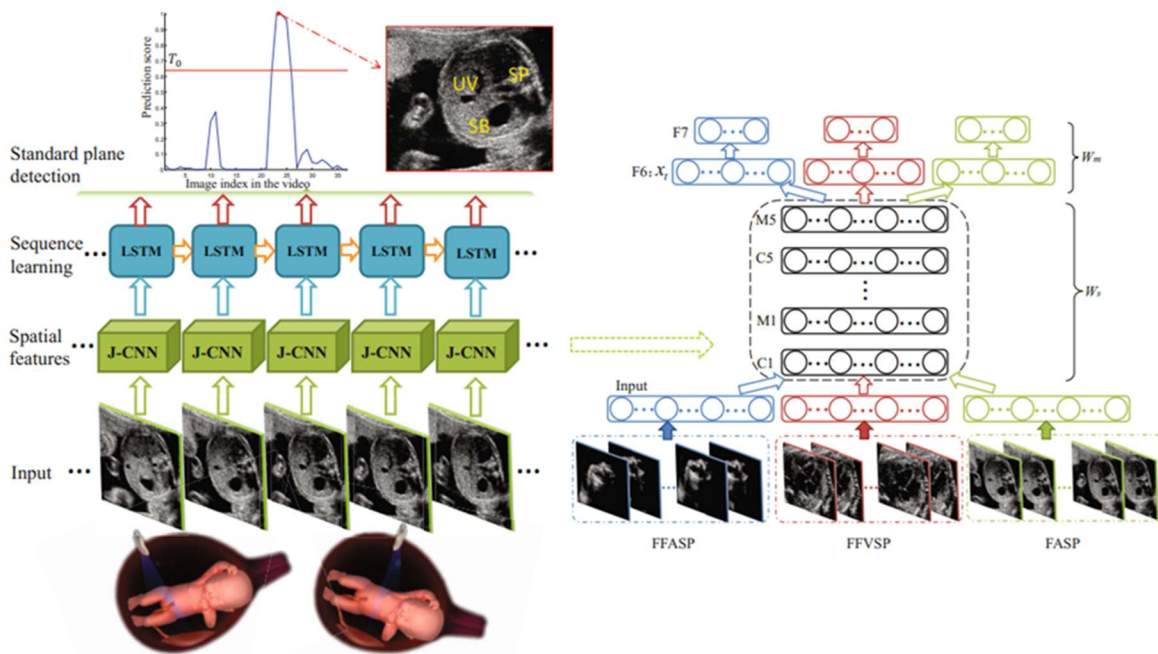

Fig. 2. Left: architecture of the proposed T-RNN; right: the proposed J-CNN.

As explained in Section IX.C.2, each depicted implementation of the J-CNN shown in Figure 2 is commonly defined, as claimed, having the same neural network architecture and parameters. Additionally, as depicted and disclosed in Figure 2, above, each ultrasound image is concurrently input, as claimed, into the respective commonly defined J-CNNs for feature extraction. Thus, Krishnan-Chen discloses all the elements of claim 5 rendering it obvious.

4. **Claim 6: “The method of claim 4, wherein the commonly defined first feature extracting neural network includes a convolutional neural network.”**

Claim 6 depends from claim 4 and is rendered obvious by Krishnan-Chen for the same reasons already provided in Section IX.C.2. Ex1002, ¶¶221-223.

5. **Claim 7: “The method of claim 4 wherein deriving the one or more extracted feature representations comprises inputting the first feature representations into a second feature extracting neural network to generate respective second feature representations, each associated with one of the ultrasound images and wherein the one or more extracted feature representations include the second feature representations.”**

Claim 7 depends from claim 4, which is rendered obvious by Krishnan-Chen. *See* Section IX.C.2. Chen also discloses the features of claim 7, thus rendering claim 7 obvious for the same reasons already provided with respect to claim 4. Ex1002, ¶¶206-209,214-215,224-228.

With reference to Figure 2, below, Chen derives one or more extracted first feature representations from a set of ultrasound images by first extracting “spatial features” from each image using convolutional neural networks. Ex1009, p.511.

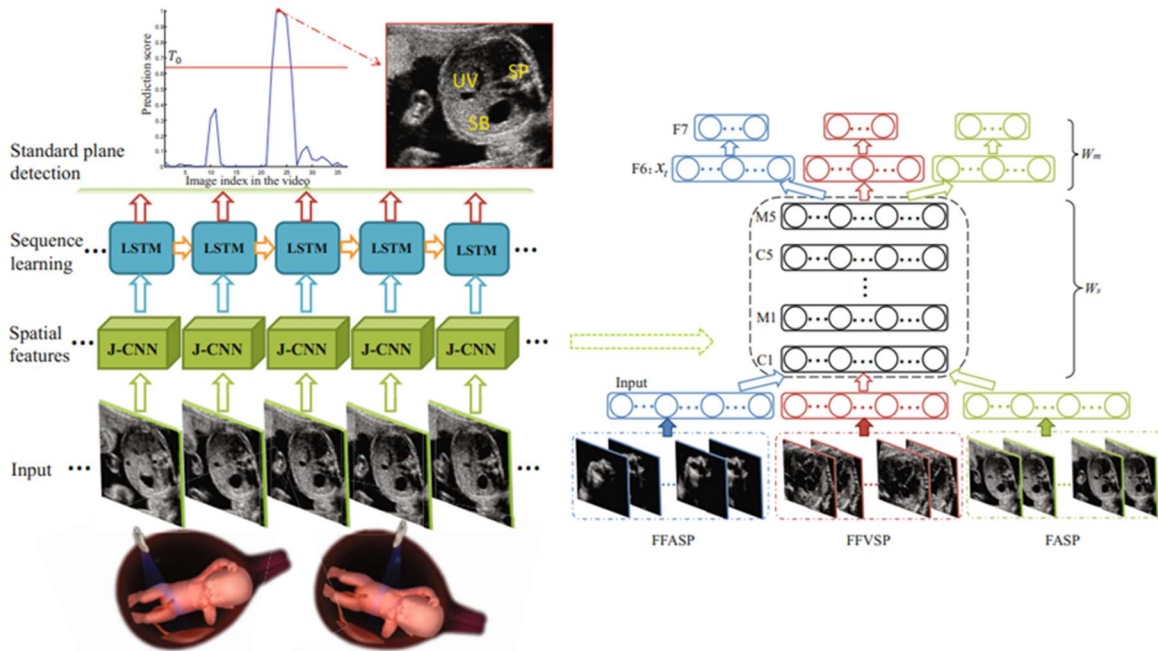

Fig. 2. Left: architecture of the proposed T-RNN; right: the proposed J-CNN.

The extracted spatial features are then input into a second feature extracting neural network (LSTM model), as claimed. *Id.* For example, Chen states: (1)“features ..., which have been detected by the J-CNN model, are further explored by the LSTM” (Ex1009, p.511); and (2) “temporal information is explored via the LSTM model based on the features ... in consecutive frames extracted from the J-CNN model” (*id.*, p.509). As depicted by the orange horizontal arrows in Figure 2, each LSTM model generates respective second feature representations for each image, which are provided to subsequent LSTM models for “sequence learning.” Ex1002, ¶¶225-226.

Ultimately, Chen identifies the view category of ultrasound images using both spatial features extracted by the J-CNN models and temporal features

extracted by the LSTM models. For example, Chen states that it “considers spatio-temporal feature representations ... for the detection of standard planes from US videos.” Ex1009, p.509. Thus, Chen discloses the elements of claim 7. Ex1002, ¶¶227-228.

6. Claim 8: “The method of claim 7 wherein the second feature extracting neural network is a recurrent neural network.”

Claim 8 depends from claim 7, which is rendered obvious by Krishnan-Chen. *See* Section IX.C.5. The LSTM models described in Chen correspond to the claimed “second feature extracting neural network.” Because these LSTM models are recurrent neural networks (Ex1009, p.509 (“recurrent neural networks (LSTM model)”), claim 8 is unpatentable over Krishnan-Chen for the same reasons as claim 7. Ex1002, ¶¶206-209,214-215,229-231.

7. Claim 23

Claim 23 depends from claim 22, which is anticipated by Krishnan. *See* Section IX.B.7. The additional limitations recited in claim 23 are substantially identical to limitations recited in claim 4 (Section IX.C.2) except, whereas claim 4 is a method claim, claim 23 is a system claim that recites “the at least one processor is configured to” perform the same function recited in claim 4. Chen discloses the limitations recited in claim 4. *See* Section IX.C.2. Additionally, Chen states that its computer-implemented process is performed by a processor (e.g., “a

2.50 GHz Intel(R) Xeon(R) E5-2609 CPU”). Ex1009, p.513. Thus, Chen discloses the limitations of claim 23. Additionally, for the same reasons explained in Sections IX.C.1 and IX.C.2, it would have been obvious to a POSITA to combine Krishnan-Chen to arrive at the subject matter in claim 23. Ex1002, ¶¶115-119,136-140,163-164,232-233.

8. Claim 24

Claim 24 depends from claim 23 and repeats, nearly identically, the limitations recited in claim 23. Accordingly, claim 24 does not add any additional limitations to claim 23 and is rendered obvious for the same reasons. Ex1002, ¶¶232-235.

9. Claim 25

Claim 25 depends from claim 24, which is rendered obvious by Krishnan-Chen. *See* Section IX.C.8. The additional limitations recited in claim 25 are essentially identical to limitations recited in claim 5 (Section IX.C.3) except, whereas claim 5 is a method claim, claim 25 is a system claim that recites “the at least one processor is configured to” perform the same function recited in claim 5. Chen discloses the limitations of claim 5. *See* Section IX.C.3. As explained in Section IX.C.7, Chen also states that its computer-implemented process is performed by a processor. Thus, Chen discloses the limitations recited in claim 25 and claim 25 is rendered unpatentable for the same reasons as claims 24 and 5.

Ex1002, ¶¶217-220, 236-237.

10. Claim 26

Claim 26 depends from claim 24, which is rendered obvious by Krishnan-Chen. *See* Section IX.C.8. The additional limitations recited in claim 26 are essentially the same as claim 7 (Section IX.C.5) except, whereas claim 7 is a method claim, claim 26 is a system claim that recites “the at least one processor is configured to” perform the same function recited in claim 7. Chen discloses the limitations of claim 7. *See* Section IX.C.5. Chen also states that its computer-implemented process is performed by a processor. *See* Section IX.C.7; Ex1002, ¶¶224-228,238-239. Thus, Chen discloses the limitations recited in claim 26 and claim 26 is rendered unpatentable for the same reasons as claims 24 and 7.

D. Ground C: Obviousness Over Krishnan in view of Aase

1. Claims 9 and 27 (“[9]/[27]”)

[9]/[27], which are reproduced in full in the Claim Index, depend from claims 2 and 22, respectively, both of which are anticipated by Krishnan. *See* Sections IX.B.2 and IX.B.7. Krishnan also anticipates [9]/[27]. *See* Sections IX.B.4 and IX.B.8. In the alternative, [9]/[27] are rendered obvious by Krishnan-Aase. Ex1002, ¶¶23-32,103-104,115-125,132-133,136-140,165-170,240-248.

Krishnan-Aase discloses [9]/[27]: Krishnan discloses a set of machine learning classifiers for performing the respective functions of quality assessment

and view identification using extracted features as input. A view identification module 104 “use[s] the extracted features/parameters to automatically identify the view of an acquired image.” Ex1005, [0019]. A quality assessment module 105 “use[s] the extracted features/parameters to assess a level of diagnostic quality of an acquired image data set.” *Id.*, [0020]. The modules 104 and 105 utilize a “bank of classifiers” or a “set of classifiers” (*id.*, [0043]), which Krishnan states can be “built using neural networks” (*id.*, [0044]). “The classifiers are implemented by the various decision support modules (102-105) for performing their respective functions.” *Id.*, [0023]. For example, “[t]hese classifiers would use the set of features as an input, and classify the image as belonging to a particular anatomy, view, or level of quality.” *Id.*, [0043]; Ex1002, ¶¶241-242.

Based on the express teachings in Krishnan, it would have been obvious to a POSITA to implement Krishnan using a view-category-specific neural network and a quality-assessment-value-specific neural network as described in Aase. Krishnan and Aase are both directed to systems for automatically identifying the view and quality of sets of ultrasound images (i.e., loops). Referring to Figure 2, below, Aase discloses a processor 132 that includes a separate quality-assessment-value-specific neural network 170 and a view-category-assignment-specific neural network 160. *Id.*

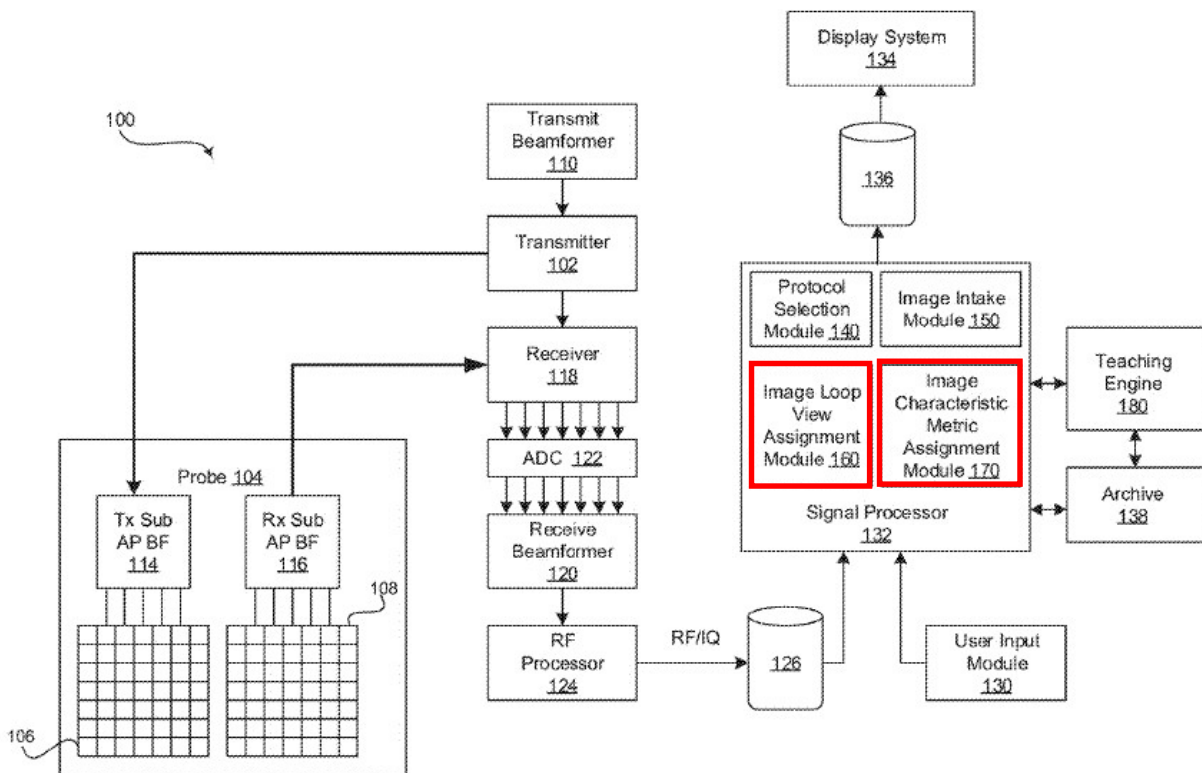

FIG. 2

Aase states that the “signal processor 132 may include an image loop view assignment module 160 ... operable to automatically assign an image view type” (Ex1006, [0032]) and “the image loop view assignment module 160 may include one or more deep neural networks” (*id.*, [0033]). Likewise, Aase states that the “signal processor 132 may include an image characteristic metric assignment module 170” (*id.*, [0034]) and “the image characteristic metric assignment module 170 may include one or more deep neural networks” that “provide an image quality score” (*id.*, [0035]).

Thus, whereas Krishnan extracts features from a set of ultrasound images

and inputs the extracted features into a bank of classifiers that perform the function of view identification and quality assessment, Aase explicitly includes a view-category-specific neural network classifier and a quality-assessment-value-specific neural network classifier. Ex1002, ¶¶243-245.

Rationale: The rationale to implement Krishnan using a view-category-specific neural network and a quality-assessment-specific neural network, as in Aase, is supplied by the express teachings of the references themselves. Krishnan already uses a “bank” or “set” of classifiers to perform a variety of functions, including view identification and quality assessment. Krishnan also teaches that the various classifiers can be neural networks. Ex1005, [0044]. A POSITA would know from Krishnan’s disclosure to use separate, function-specific classifiers to perform the respective functions. Ex1002, ¶¶245-246. Indeed, a POSITA familiar with the design and training of neural network classifiers would expect to use separate classifiers to perform separate functions since the training of a single classifier to perform multiple functions would be more complicated and require more training data. Ex1002, ¶¶246. Aase makes explicit what Krishnan already discloses or suggests, i.e., a quality-assessment-specific neural network can be used to assess quality, and a view-assignment-specific neural network can be used to identify the view category.

Reasonable expectation of success: A POSITA would also have had a

reasonable expectation of success since Krishnan and Aase are directed to the same field of endeavor, and Krishnan already expressly describes using a bank or set of neural network classifiers. Implementing Krishnan in a manner that achieves the claimed subject matter would not require any material modification or experimentation. Ex1002, ¶¶247-248.

2. Claims 10 and 28 (“[10]/[28]”)

[10]/[28], which are reproduced in full in the Claim Index, depend from [9]/[27], respectively, both of which are rendered obvious by Krishnan-Aase. For reasons already explained in Section IX.D.1 above, [10]/[28] are also rendered obvious by Krishnan-Aase. Ex1002, ¶¶240-254.

[10]/[28] add: (i) “[inputting/input] each of the one or more extracted feature representations into an implementation of a commonly defined quality assessment value specific neural subnetwork”; and (ii) “[inputting/input] each of the one or more extracted feature representations into an implementation of a commonly defined image property specific neural network.” In contrast to [5]/[25], [10]/[28] do not require “concurrently” inputting into a “respective” implementation of a

commonly defined neural network.³

Krishnan states that “the image dataset will be processed to ... extract relevant feature data from the image dataset” where “[t]hese features could include any kind of characteristic” and “can be obtained across images, such as motion of a particular point, or the change in a particular feature across images.” Ex1005, [0034]. Thus, Krishnan evaluates the extracted feature representations from each respective image within the data set. *See also*, Ex1005, [0020] (“using the extracted features/parameters to assess a level of diagnostic quality of an acquired image data set”). Krishnan-Aase further teaches inputting the extracted features from a set of ultrasound images into separate quality assessment and view identification specific neural network classifiers, as claimed. *See* Section IX.D.1. Thus, Krishnan-Aase teaches all the elements of [10]/[28]. Ex1002, ¶¶249-254.

E. Ground D: Obviousness over Krishnan in view of Chen and Wu

Independent claim 12 and the claims that depend from it (“the training claims”) are directed to a “computer-implemented method of training one or more”

³ For context, in the California Litigation, Patent Owner alleges that [10]/[28] are infringed by a product having a single convolutional neural network with a single input where ultrasound image frames are input one at a time in series for evaluation by the same neural network layers. Ex1002, ¶251.

neural networks to facilitate ultrasonic image analysis.” The Patent does not, however, describe a new technique for training neural networks. Instead, the method recited in the training claims is a standard neural network training technique comprising (i) using pre-labeled training images as input, and (ii) adjusting the neural network parameters (e.g., weights and biases) to predict—with minimal error—the training labels at the neural network output. *See, e.g.*, Ex1012, p.516 (describing “Training methods for artificial neural networks”); Ex1017, p.450 (“For a network to be trained ... a ‘training’ data set of example inputs and their corresponding desired outputs is required.... During learning the example inputs are presented to the network and the resultant and desired outputs are compared.”); Ex1018, [0037], [0040]-[0041], [0046], [0084] (“common method of training artificial neural networks”); Ex1002, ¶¶255-257. Thus, once it is determined that Krishnan discloses neural network classifiers that perform the same functions recited in the claims (i.e., quality assessment and view category assignment for a set of ultrasound images), the training claims are also rendered obvious because a POSITA would already know how to train such networks using well-known, standard methods. Ex1002, ¶¶49-50,54-57,256.

1. Claim 12

Claim 12 is rendered obvious by Krishnan-Chen-Wu. Krishnan discloses a method for analyzing a set of ultrasound images using a bank of neural network

classifiers to determine a view category and quality assessment of the images. Pertinent to claim 12, Chen and Wu describe methods for training a view category neural network classifier and a quality assessment neural network classifier, respectively. Ex1002, ¶¶258-260.

Rationale to combine: Krishnan, Chen, and Wu are all directed to the same field of ultrasound image analysis using machine learning techniques. A POSITA would have been motivated to combine these references based on the knowledge of the POSITA and/or the teachings and motivations expressed in the references themselves. Ex1002, ¶261.

Krishnan discloses classifiers that perform view identification and quality assessment. Ex1005, [0019] (“view identification module”), [0020] (“quality assessment module”), [0023] (“one or more classifiers”). “The classifiers can be implemented using machine learning methods” (Ex1005, [0006], [0023]), including “neural networks.” *Id.*, [0042]-[0044]. Chen and Wu disclose sample recurrent neural network architectures for extracting feature data from a sequential set of ultrasound images and performing the same functions of view identification and quality assessment. It would have been natural and obvious to a POSITA to combine the teachings of Krishnan, Chen, and Wu by using the neural network architectures disclosed in Chen and Wu to perform the same features described in Krishnan. Ex1002, ¶262.

Furthermore, Krishnan's "machine learning" neural network classifiers need to be trained. *See* Ex1005, [0023] ("learning engine (109) includes methods for training/building one or more classifiers using training data ... of previously ... labeled cases"). And Chen and Wu describe techniques for training such classifiers. Ex1002, ¶¶262-263. A POSITA would have been motivated to implement the respective neural networks and training methods described in Chen and Wu, with Krishnan, for their intended purpose (i.e., ultrasound view identification and quality assessment, respectively).

Reasonable expectation of success: A POSITA would have had a reasonable expectation of success combining the teaching of Krishnan, Chen, and Wu, because all relate to the use of neural network classifiers trained by labeled training images. Ex1005, [0023] ("training/building ... classifiers using train data ... of previously diagnosed/labeled cases"); Ex1009, p.512 ("For training the ... classifier ..., training samples ... were generated" and "manually annotated by an experiences obstetrician."); Ex1010, p.1341 (pdf p.6) ("The annotation of all training data for the [convolutional neural networks] was initially done by a graduate student."). Additionally, Chen expressly states that it discloses "a general framework and can be easily extended to other [ultrasound] standard plane or anatomical structure detection problems." Ex1009, p.509. Likewise, Wu also states that its "proposed [quality assessment] scheme can be easily generalized to

other types of fetal [ultrasound] views.” Ex1010, p.1338 (pdf p.3); Ex1002, ¶¶262-263.

Krishnan-Chen-Wu discloses claim 12:

- a) **[12(pre)]: “A computer-implemented method of training one or more neural networks to facilitate ultrasonic image analysis, the method comprising:”**

Krishnan discloses [12(pre)] to the extent it is a limitation. *See, e.g.*, Ex1005, Fig. 1 (“Learning Engine 109”), [0023] (“The learning engine (109) includes methods for training/building one or more classifiers using training data that is learned from the database (106) of previously diagnosed/labelled cases.”), [0044] (“classifiers are built using neural networks”), [0016] (“methods for analyzing medical image data ... (e.g., ultrasound image data)”). Chen and Wu are likewise directed to computer-implemented methods of training neural networks for ultrasound image analysis. Ex1009, p.513 (“The ... method generally took less than 1 minute to detect the standard planes from a video containing 40 frames using a workstation equipped with a ... CPU.”), p.509 (“classifier is first trained based on the joint learning of convolutional neural networks ... for [ultrasound] standard plane detection”), p.510 (describing the training of common (C1 to M5) and view-specific (F6 and F7) neural network layers); Ex1010, Abstract (“The proposed [fetal ultrasound image quality assessment] is realized with two deep convolutional neural network models, which are denoted as L-CNN and C-CNN,

respectively.”), p.1341 (pdf p.6) (describing the training of L-CNN and C-CNN); Ex1002, ¶264.

b) [12(a)]: “receiving signals representing a plurality of sets of ultrasound training images;”

Krishnan discloses [12(a)]. Ex1005, [0016]-[0017] (“ultrasound image data”). With reference to Figure 1, reproduced below, Krishnan states: “The database (106) may comprise a plurality of labeled/diagnosed medical images ... which are indexed ... based on relevant features/parameters.” Ex1005, [0021].

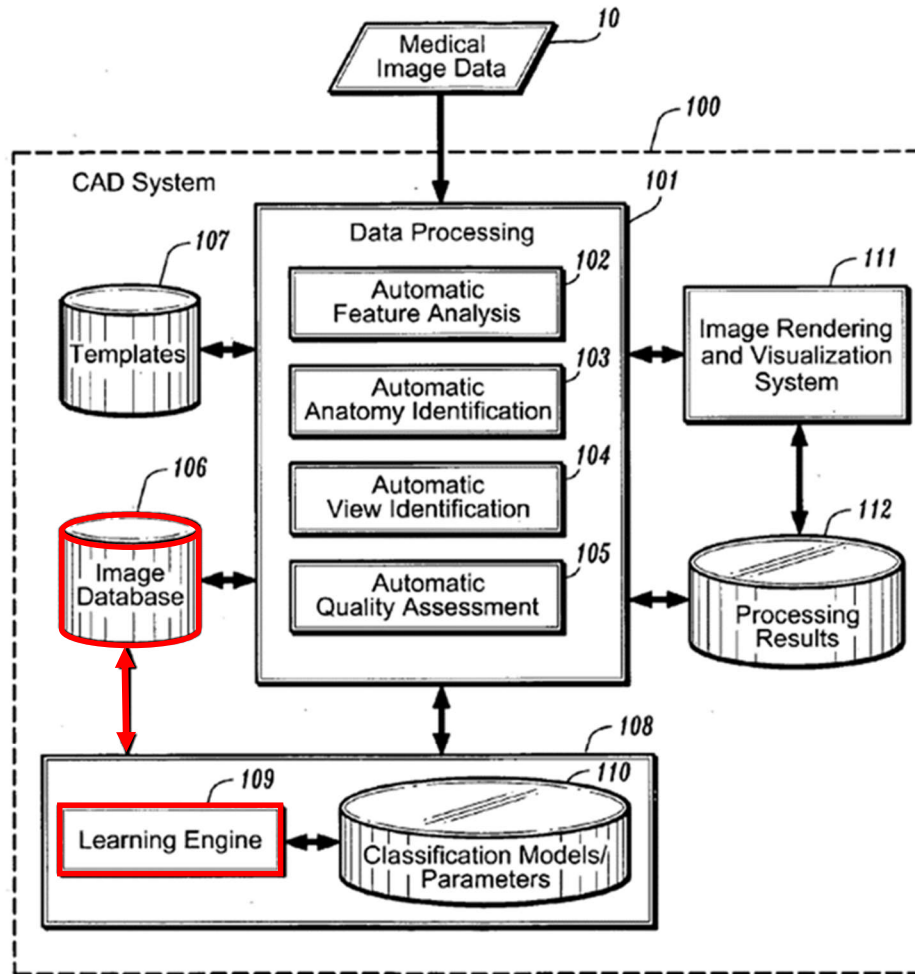

FIG. 1

“The learning engine (109) includes methods for training/building one or more classifiers using training data that is learned from the database (106) of previously diagnosed/labelled cases.” *Id.*, [0023] (emphasis added); Ex1002, ¶265.

- c) [12(b)]: “receiving signals representing quality assessment values, each of the quality assessment values associated with one of the sets of ultrasound training images and representing a quality assessment of the associated set of ultrasound training images;”

Krishnan teaches or suggests [12(b)] to a POSITA. Ex1002, ¶¶266-267.

Wu also discloses this feature. Ex1002, ¶268.

Krishnan trains one or more classifiers “using training data ... from the database (106) of previously diagnosed/labeled cases.” Ex1005, [0023]. One or more of the trained classifiers is implemented to “determine[e] a quality measure within a predefined range of values to provide an indication as [to] the quality level of the acquired images.” *Id.*, [0020], [0036]. A POSITA would be familiar with the standard method for training neural network classifiers using pre-labeled images. Ex1002, ¶¶49-50,54-57, 267; Ex1017, p.450 (“For a network to be trained ... a ‘training’ data set of example inputs and their corresponding desired outputs is required.... During learning the example inputs are presented to the network and the resultant and desired outputs are compared.”). Thus, if the desired output of one of Krishnan’s classifiers is a quality assessment value, then a POSITA would know that the training input to the classifier would include images labeled with quality assessment values. Ex1002, ¶267.

Wu explicitly uses “training sample” ultrasound images to train neural network classifiers to provide quality assessment values. Ex1010, p.1341 (pdf p.6). The training samples include thousands of images in each quality class (1-4) where “annotation of all training data ... was done by a graduate student....” *Id.* Thus, Wu discloses [12(b)]. Ex1002, ¶268.

- d) **[12(c)]: “receiving signals representing image properties, each of the image properties associated with one of the sets of ultrasound training images; and”**

Krishnan teaches or suggests [12(c)] to a POSITA. Ex1002, ¶¶269-70. Chen also discloses this feature. Ex1002, ¶271.

The Patent states that “image properties” may be a “view category.” Ex1001, 1:50, 17:1-2. Krishnan implements one or more trained classifiers to “automatically identify the view of an acquired image.” *Id.*, [0019], [0023]. The classifiers are trained “using training data ... from the database (106) of previously diagnosed/labeled cases.” Ex1005, [0023]. Since one of Krishnan’s neural network classifiers is trained to identify view category, a POSITA would understand that the neural network would be trained using images labeled by their view category. Ex1017, p.450; Ex1002, ¶270.

Chen explicitly describes training its “ROI classifier under the framework of J-CNN” using “training samples” that correspond to standard views/planes where the training images “were manually annotated by an experienced obstetrician.” Ex1009, p.512; Ex1002, ¶271.

- e) **[12(d)]: “training a neural network, the training comprising, for each set of the plurality of sets of ultrasound training images, using the set of ultrasound training images as an input to the neural network and using the quality assessment values and the image properties associated with the set of ultrasound training images as desired outputs of the neural network.”**

Krishnan teaches or suggests [12(d)] to a POSITA. Ex1002, ¶¶272-273.

Krishnan trains one or more neural network classifiers to perform view identification and quality assessment “using training data ... from the database (106) of previously diagnosed/labeled cases.” Ex1005, [0023], [0044]. This “training data” is used in conjunction with “a learning engine (109)” that “includes methods for training/building one more classifiers using training data that is learned from database (106).” *Id.* A POSITA would understand how neural networks are typically trained and know, therefore, that the “training data” would include “previously diagnosed/labeled” images labeled with associated “quality assessment” or “image property” data, as discussed above with respect to [12(a)], [12(b)], and [12(c)]. Ex1002, ¶273. A POSITA would also understand that training the neural network would consist of using the training images as input to the neural network and adjusting the neural network parameters based on the training labels associated with the images being the “desired output of the neural network.” Ex1002, ¶273; Ex1018, [0037], [0040]-[0041] (describing the training of neural networks using training images as input and a back-propagation algorithm

to minimize “the difference between the input and output values”).

2. Claim 13

Claim 13, which is fully reproduced in the Claim Index, depends from claim 12, which is rendered obvious by Krishnan-Chen-Wu. Krishnan-Chen-Wu also renders obvious claim 13 because the image property determined by Krishnan is a view category associated with a set of ultrasound images. Ex1005, [0023]; Ex1002, ¶¶274-275. Chen likewise determines the standard views of sets of ultrasound images. Ex1009, p.512; Ex1002, ¶274.

3. Claim 14

Claim 14, which is fully reproduced in the Claim Index, depends from claim 13 and recites a “feature extracting neural network,” an “image property specific neural network,” and a “quality assessment value specific neural network.” Each of these neural networks is configured to take various input and produce output corresponding to their respective functions—e.g., “feature representations,” “image property,” or “quality assessment value.”

Krishnan-Chen-Wu renders obvious claim 14. Krishnan discloses a plurality of modules (102-105) for performing the respective functions of feature extraction, quality assessment, and view identification. Ex1005, [0016], [0019], [0020]; Ex1002, ¶¶276-277.

Krishnan states that the various modules (102-105) utilize “one or more

trained classification models,” also referred to as a “bank of classifiers” or a “set of classifiers” (*id.*, [0043]), which Krishnan states can be “built using neural networks” (*id.*, [0044]). “The classifiers are implemented by the various decision support modules (102-105) for performing their respective functions.” *Id.*, [0023] (emphasis added). Ex1002, ¶278.

Thus, Krishnan discloses the “feature extracting neural network,” “image property specific neural network,” and “quality assessment value specific neural network,” as claimed. Additionally, Krishnan discloses that the image property neural network takes extracted feature representations as input and outputs an image property (view), as claimed, and that the quality assessment neural network takes the extracted features as input and outputs a quality assessment value, as claimed. Ex1005, [0043]; Ex1002, ¶¶278-279. Finally, Krishnan teaches that its neural network classifiers are trained based on training data comprising previously labeled images (Ex1005, [0023]) such that its feature extracting neural network is configured to take training images as input and output extracted feature representations, as claimed. *Id.*, ¶¶279-280.

4. Claim 15

Claim 15, which is fully reproduced in the Claims Index, depends from claim 14, which is rendered obvious by Krishnan-Chen-Wu. *See* Section IX.E.3. Krishnan-Chen-Wu also renders obvious claim 15.

As already explained in Section IX.B.1.b, above, the medical image dataset obtained by Krishnan can include one or more ultrasound images. As also explained in Section IX.B.1.c, above, “the image dataset will be processed to ... extract relevant feature data from the image dataset” where “[t]hese features could include any kind of characteristic” and “can be obtained across images, such as motion of a particular point, or the change in a particular feature across images.” Ex1005, [0034] (emphasis added). Since Krishnan describes extracting features from a dataset to track the change in a particular feature across multiple images, it discloses deriving a first feature representation for each image within the dataset, as claimed. Ex1002, ¶¶281-283.

5. Claim 16

Claim 16, which is fully reproduced in the Claims Index, depends from claim 15, which is rendered obvious by Krishnan-Chen-Wu. *See* Section IX.E.4. Krishnan-Chen-Wu also renders obvious claim 16 for reasons similar to claim 4. *See* Section IX.C.2; Ex1002, ¶¶211-216,284-290.

Krishnan discloses that its classification methods may be implemented via trained neural networks, including a feature extracting neural network. Ex1005, [0016], [0019], [0020], [0023], [0043]-[0044]; Ex1002, ¶¶285-286. Referring to Figure 2, below, Chen discloses a particular neural network structure that extracts spatial feature representations from a sequence of ultrasound images by inputting

each consecutive frame of an ultrasound video into respective J-CNNs that are commonly defined by the same neural network parameters. Ex1009, p.509 (“Fig. 2 Left: architecture of the proposed T-RNN; right: the proposed J-CNN”).

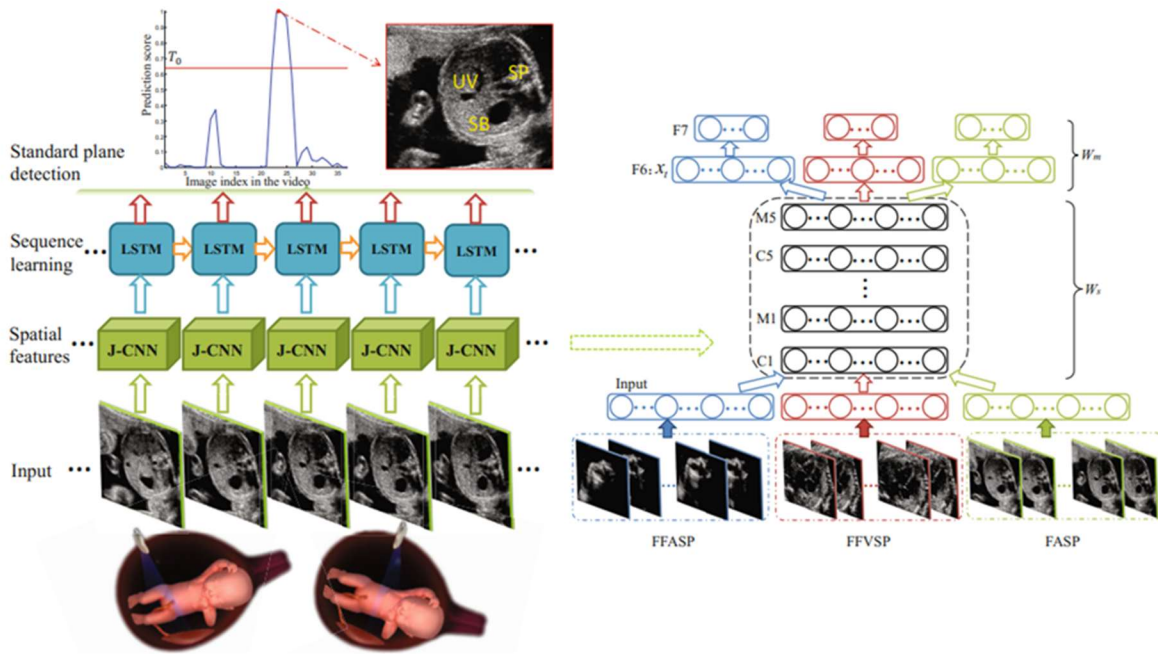

Fig. 2. Left: architecture of the proposed T-RNN; right: the proposed J-CNN.

Chen also discloses a method for training the feature extracting J-CNNs using training images. Ex1009, p.509-510 (“a joint learning model for effective spatial feature learning across multi-tasks is presented”) (“A ROI classifier is first trained based on the joint learning of convolutional neural networks (J-CNN) across multi-tasks to locate the most discriminative regions for US standard plane detection.”) (describing the training to determine the parameters in W_s and W_m of the J-CNN depicted in Figure 2). Thus, Chen discloses the features of claim 16.

And, as already explained in Sections IX.C.1 and IX.E.1, it would be natural and obvious for a POSITA to use the neural network structure and training methods described in Chen to perform the same feature extracting function described in Krishnan. Ex1002, ¶287-290.

6. Claim 17

Claim 17 depends from claim 16, which is rendered obvious by Krishnan-Chen-Wu. *See* Section IX.E.5. Krishnan-Chen-Wu also renders obvious claim 17 for reasons similar to claim 5. *See* Section IX.C.3; Ex1002, ¶¶291-294.

As discussed immediately above, Krishnan discloses ultrasound image classification methods implemented via neural networks, including a feature extracting neural network trained using previously labeled images. Ex1005, [0016], [0019], [0020], [0023], [0043]-[0044]; Ex1002, ¶292. As also discussed above, it would have been obvious to a POSITA to implement Krishnan's feature extraction using the neural network structure and training methods disclosed in Chen. With reference to Figure 2, below, Chen "concurrently" extracts features from a set of ultrasound images by inputting each consecutive frame of an ultrasound video into a respective, common-defined J-CNN that extracts spatial features from the frame. Ex1002, ¶¶292-294. Thus, Chen discloses the features of claim 17.

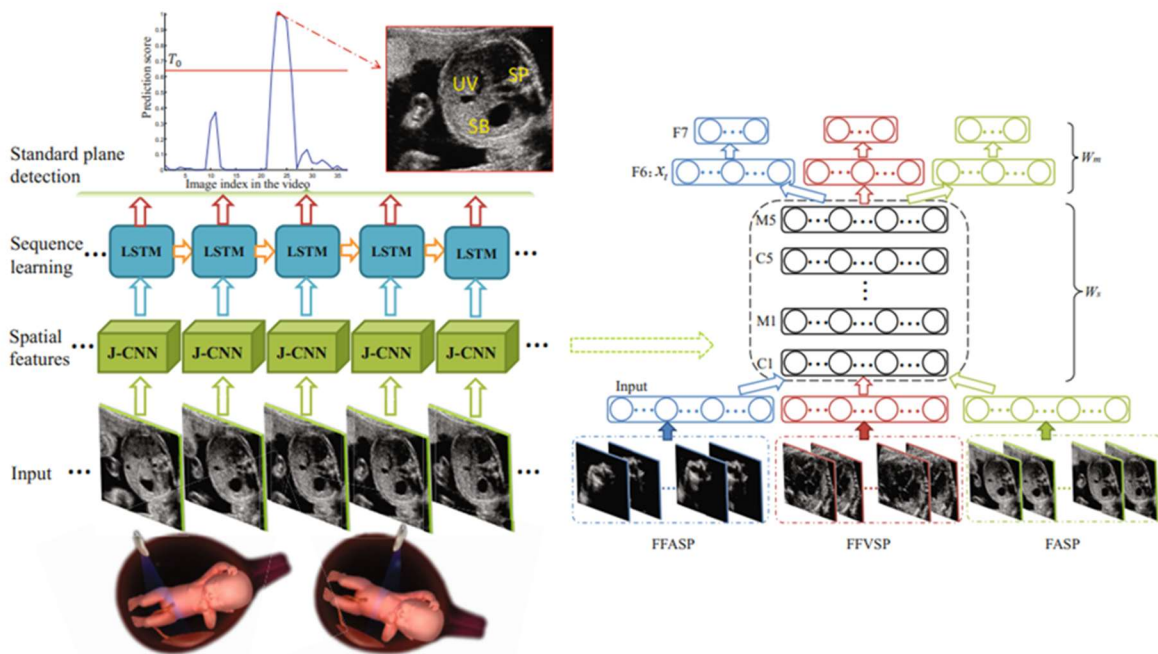

Fig. 2. Left: architecture of the proposed T-RNN; right: the proposed J-CNN.

7. Claim 18

Claim 18 depends from claim 16, which is rendered obvious by Krishnan-Chen-Wu. *See* Section IX.E.5. Krishnan-Chen-Wu also renders obvious claim 18. As discussed above, and depicted in Figure 2, Chen discloses a “J-CNN” (Joint-Convolutional Neural Network) as a sub-network within an overall T-RNN network. Each J-CNN is commonly defined, as claimed. Ex1009, p.509 (“Fig. 2 Left: architecture of the proposed T-RNN; right: the proposed J-CNN”); Ex1002, ¶¶295-296.

8. Claim 19

Claim 19, which is reproduced in full in the Claim Index, depends from

claim 16, which is rendered obvious by Krishnan-Chen-Wu. *See* Section IX.E.5. Krishnan-Chen-Wu also renders obvious claim 19 for reasons similar to claim 7. *See* Section IX.C.5; Ex1002, ¶¶224-228,297-302.

As discussed above, Krishnan discloses a “set of classifiers,” which can be neural networks, for performing the described functions of feature extraction, quality assessment, and view identification. Ex1005, [0016], [0019], [0020]; Ex1002, ¶¶298-299. As also discussed above, it would have been obvious to a POSITA to implement the feature extraction functionality described in Krishnan using the feature extracting neural network structure disclosed in Chen.

Claim 19 recites a “second feature extracting neural network.” Chen discloses this structure and functionality. With reference to Figure 2, below, Chen derives one or more extracted feature representations from a set of ultrasound images, as claimed, by first extracting “spatial features” from each image using convolutional neural networks. Ex1009, p.511.

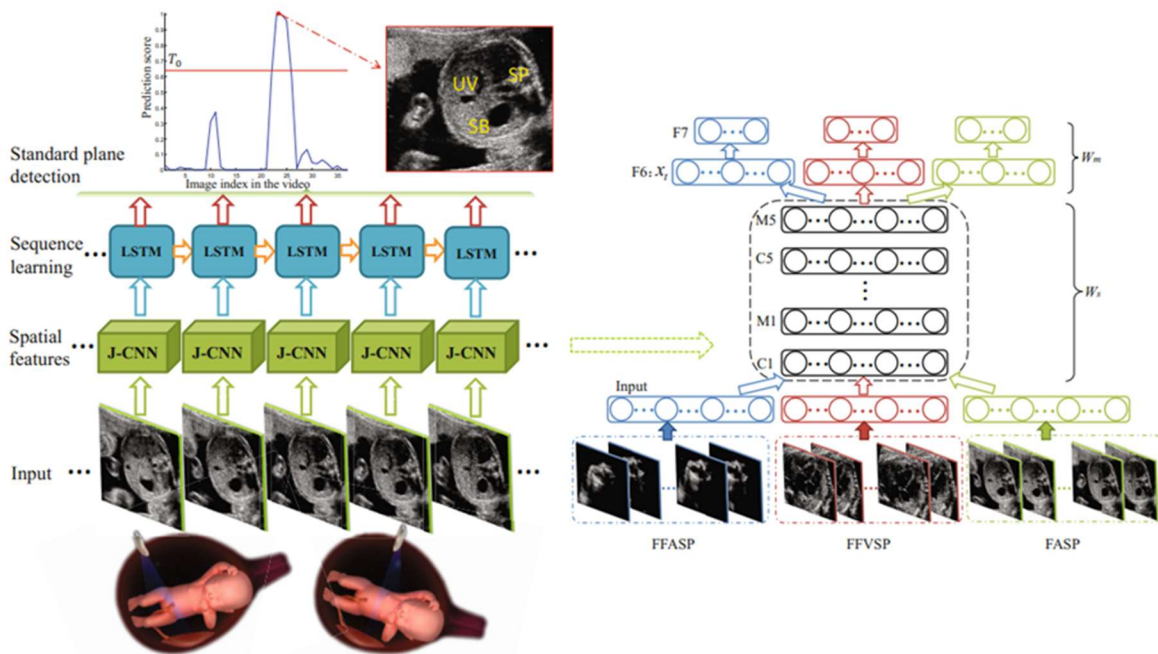

Fig. 2. Left: architecture of the proposed T-RNN; right: the proposed J-CNN.

The extracted spatial feature is then input into a second feature extracting neural network (LSTM model), as claimed. *Id.* For example, Chen states: (1) “features ..., which have been detected by the J-CNN model, are further explored by the LSTM” (Ex1009, p.511); and (2) “temporal information is explored via the LSTM model based on the features ... in consecutive frames extracted from the J-CNN model” (*id.*, p.509). As depicted by the orange horizontal arrows in Figure 2, each LSTM model then generates respective second feature representations for each image, which are provided to subsequent LSTM models for “sequence learning.” Ex1002, ¶¶300-301. Thus, Chen discloses, as claimed, inputting the first feature representations into a second feature extracting neural network to generate

respective second feature representations, each associated with one of the ultrasound images. Ex1002, ¶¶301-302.

9. Claim 20

Claim 20 depends from claim 19, which is rendered obvious by Krishnan-Chen-Wu. The LSTM models described in Chen correspond to the claimed “second feature extracting neural network.” These LSTM models are recurrent neural networks. Ex1009, p.509 (“recurrent neural networks (LSTM model)”). Thus, Krishnan-Chen-Wu also renders obvious claim 20. Ex1002, Ex1002, ¶¶303-305.

X. CONCLUSION

Based on the strength of the identified grounds, the Board should institute review of the challenged claims.

* * *

Date: August 15, 2025

By: / Jeffrey C. Metzcar /
Jeffrey C. Metzcar
Registration No. 52,027
THOMPSON HINE LLP
10050 Innovation Drive, Suite 400
Dayton, OH 45342

David R. Jaglowski
Registration No. 58,514
THOMPSON HINE LLP
41 South High Street, Suite 1700
Columbus, Ohio 43215

Marla R. Butler
THOMPSON HINE LLP
Two Alliance Center
3560 Lenox Road, NE., Suite 1600
Atlanta, GA 30326-4266

William E. Manske
THOMPSON HINE LLP
800 Nicollet Avenue, Suite 2925
Minneapolis, MN 55402

CERTIFICATION UNDER 37 C.F.R. § 42.24(D)

Pursuant to 37 C.F.R. §42.24(a)(1)(i), I certify that this paper includes 13,917 words. In accordance with 37 C.F.R. §42.24(a)(1), this word count does not include a count of the words in a table of contents, a table of authorities, mandatory notices under §42.8, a certificate of service or word count, or appendix of exhibits or claim listing. Furthermore, in accordance with 37 C.F.R. §42.24(d), this word count is the word count of the word-processing system used to prepare the paper.

Date: August 15, 2025

/ David R. Jaglowski /
David R. Jaglowski
Registration No. 58,514
THOMPSON HINE LLP
41 South High Street, Suite 1700
Columbus, Ohio 43215

CERTIFICATE OF SERVICE

Pursuant to 37 C.F.R. §§42.6 and 42.105, the undersigned hereby certifies that a true and correct copy of the Petition for *Inter Partes* Review in connection with U.S. Patent No. 10,751,029 and supporting evidence was served on August 15, 2025, upon agreement of the parties, via electronic mail on the following counsel of record for Patent Owner, University of British Columbia:

Vlad Teplitskiy
vlad.teplitskiy@knobbe.com
KNOBBE MARTENS OLSON & BEAR LLP
2040 Main Street 14th Floor
Irvine, CA 92614

Courtesy copies were also served via electronic mail on Patent Owner's counsel of record in a related district court litigation and IPR2025-01066:

Jessica C. Kaiser
kaiser-ptab@perkinscoie.com
PERKINS COIE LLP
1900 Sixteenth St. Suite 1400
Denver, CO 80202-5255

Ramsey M. Al-Salam
ralsalam@perkinscoie.com
PERKINS COIE LLP
1301 Second Avenue Suite 4200
Seattle, WA 98101-3805

Christopher Marando
Marando-ptab@perkinscoie.com
PERKINS COIE LLP
700 Thirteenth Street N.W. Suite 800
Washington, DC 20005-3960

Moeka Takagi
mtakagi@perkinscoie.com
PERKINS COIE LLP
3150 Porter Drive
Palo Alto, CA 94304-1212

Dorianne Salmon
DSalmon@perkinscoie.com
PERKINS COIE LLP
1201 Third Avenue, Suite 4900
Seattle, Washington 98101-3099

Date: August 15, 2025

/ Andrew C. Himebaugh /
Andrew C. Himebaugh
THOMPSON HINE LLP
20 N. Clark Street, Suite 3200
Chicago, Illinois 60602