



US 20060286729A1

(19) **United States**

(12) **Patent Application Publication**

Kavalieros et al.

(10) **Pub. No.: US 2006/0286729 A1**

(43) **Pub. Date: Dec. 21, 2006**

(54) **COMPLEMENTARY METAL OXIDE SEMICONDUCTOR INTEGRATED CIRCUIT USING RAISED SOURCE DRAIN AND REPLACEMENT METAL GATE**

(21) Appl. No.: 11/159,430

(22) Filed: Jun. 21, 2005

Publication Classification

(51) **Int. Cl.**
H01L 21/338 (2006.01)

(52) **U.S. Cl.** 438/183

(76) Inventors: **Jack Kavalieros**, Portland, OR (US);
Annalisa Cappellani, Portland, OR (US);
Justin K. Brask, Portland, OR (US);
Mark L. Doczy, Beaverton, OR (US);
Matthew V. Metz, Hillsboro, OR (US);
Suman Datta, Beaverton, OR (US);
Chris E. Barns, Portland, OR (US);
Robert S. Chau, Beaverton, OR (US)

(57) **ABSTRACT**

A complementary metal oxide semiconductor integrated circuit may be formed with a PMOS device formed using a replacement metal gate and a raised source drain. The raised source drain may be formed of epitaxially deposited silicon germanium material that is doped p-type. The replacement metal gate process results in a metal gate electrode and may involve the-removal of a nitride etch stop layer.

Correspondence Address:
TROP PRUNER & HU, PC
1616 S. VOSS ROAD, SUITE 750
HOUSTON, TX 77057-2631 (US)

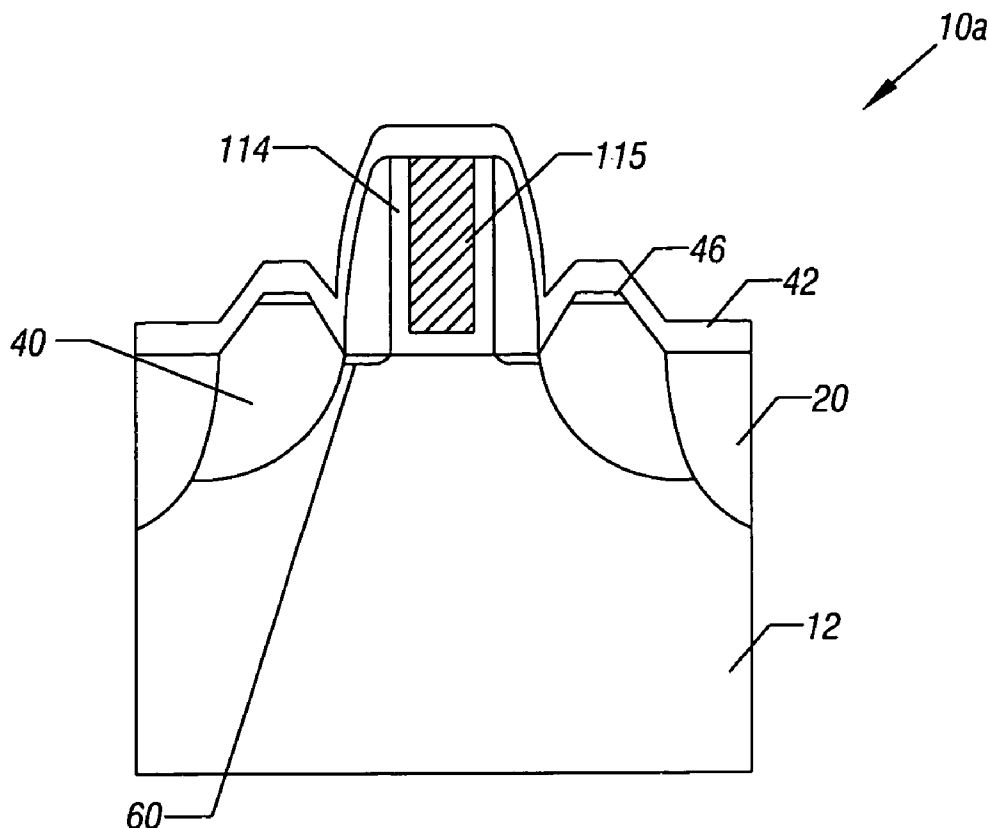

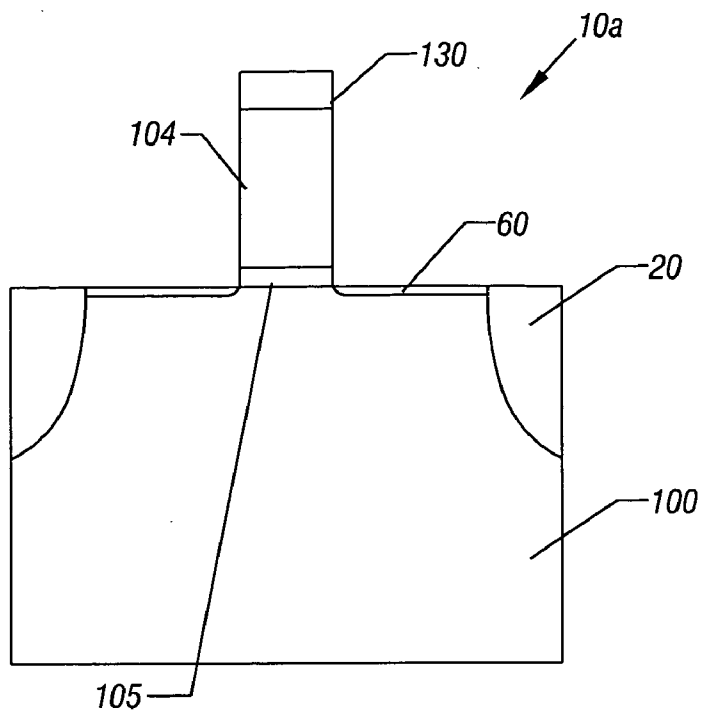

FIG. 1

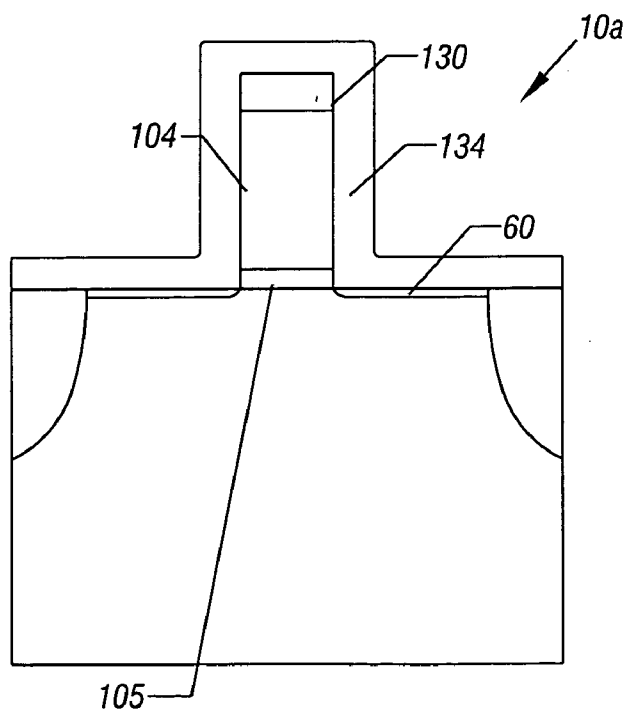

FIG. 2

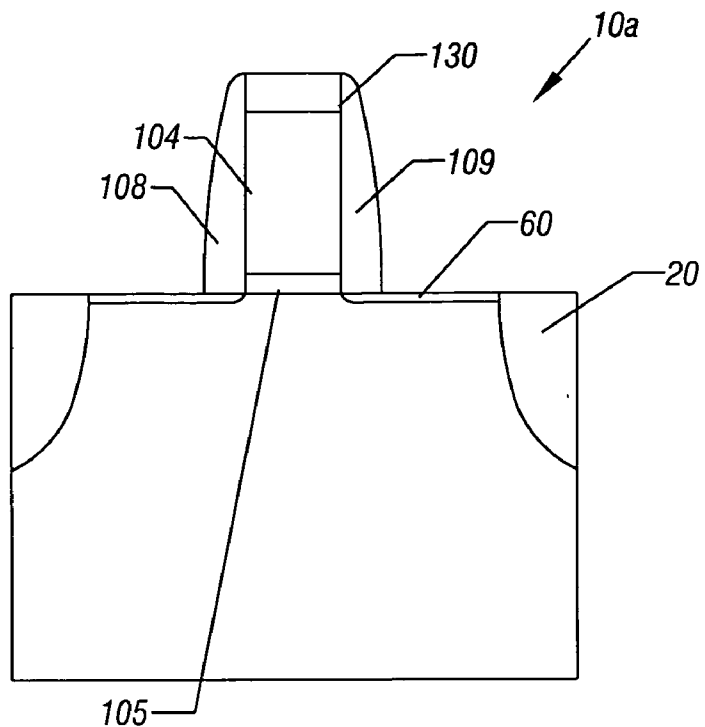

FIG. 3

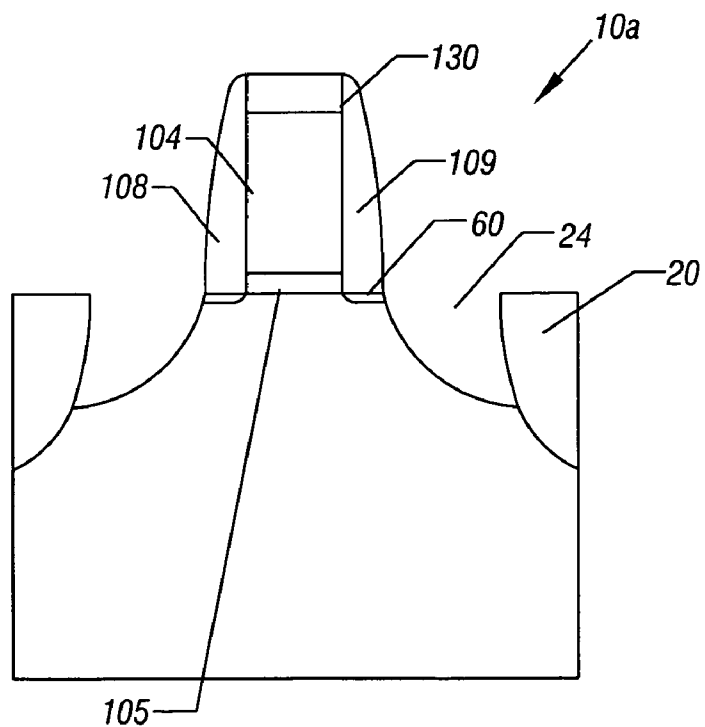

FIG. 4

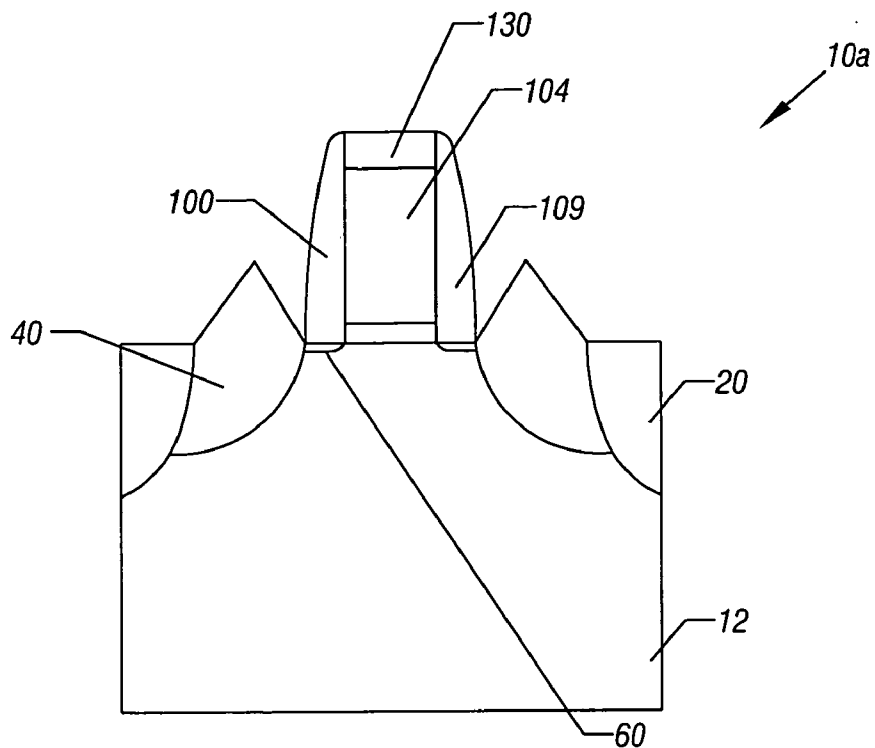

FIG. 5

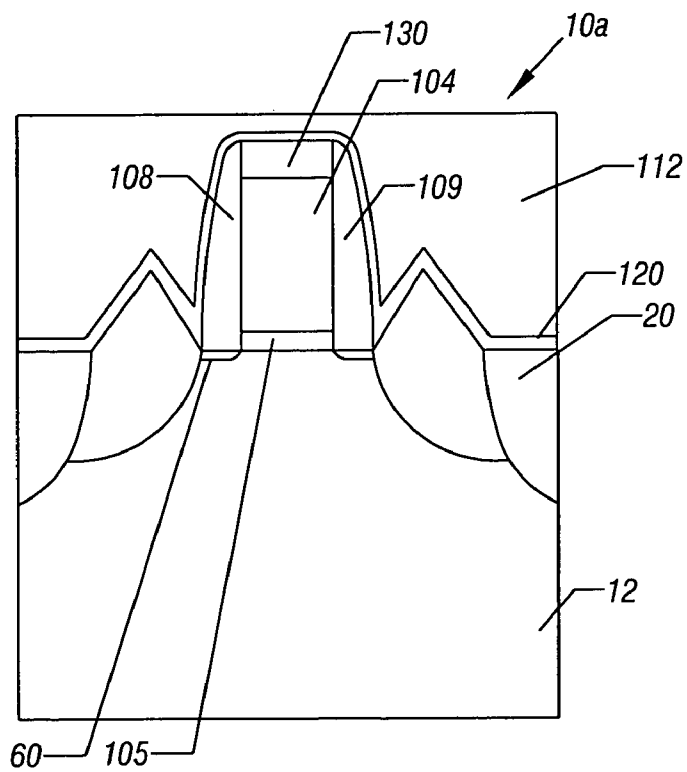

FIG. 6

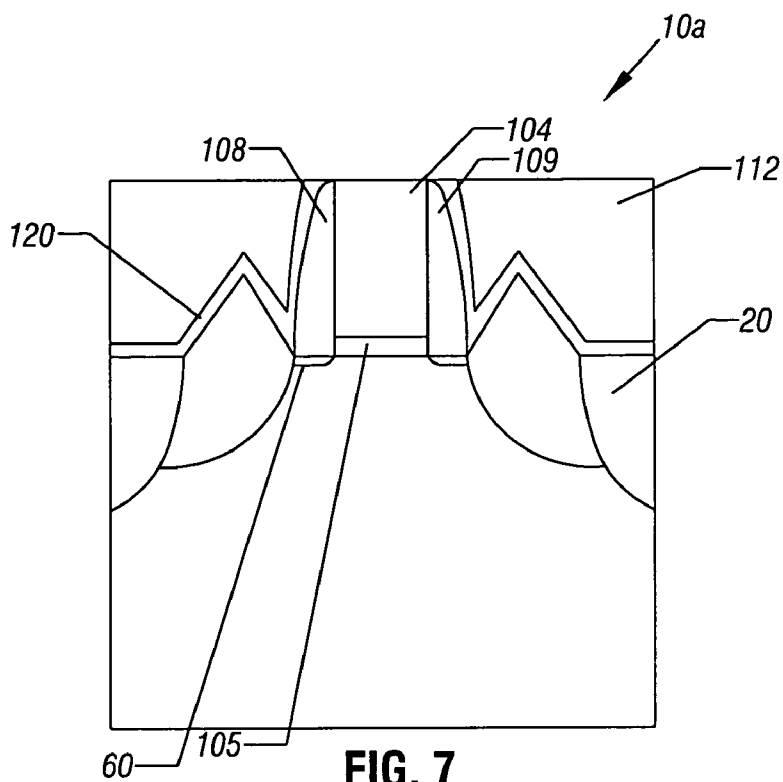

FIG. 7

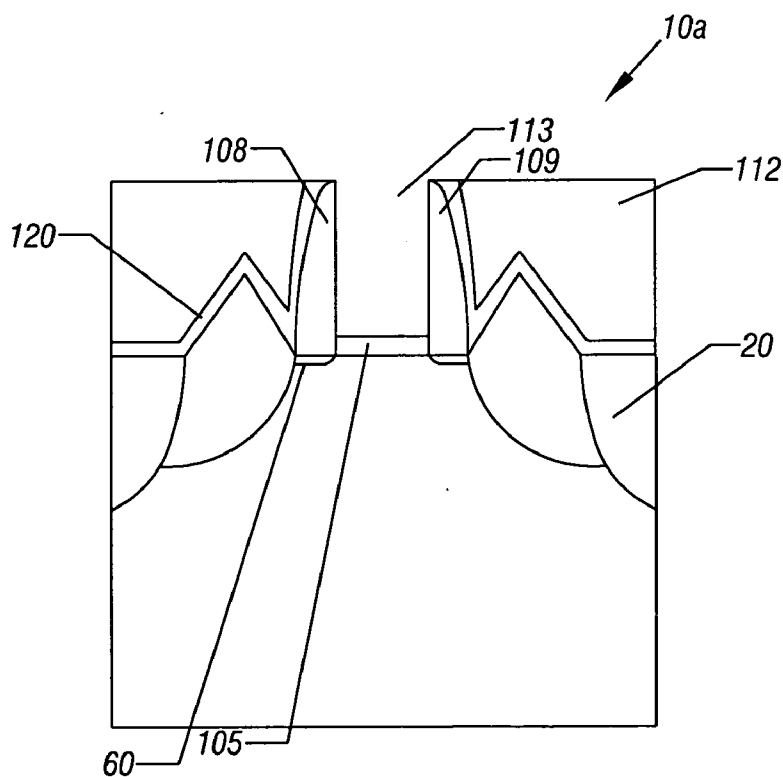

FIG. 8

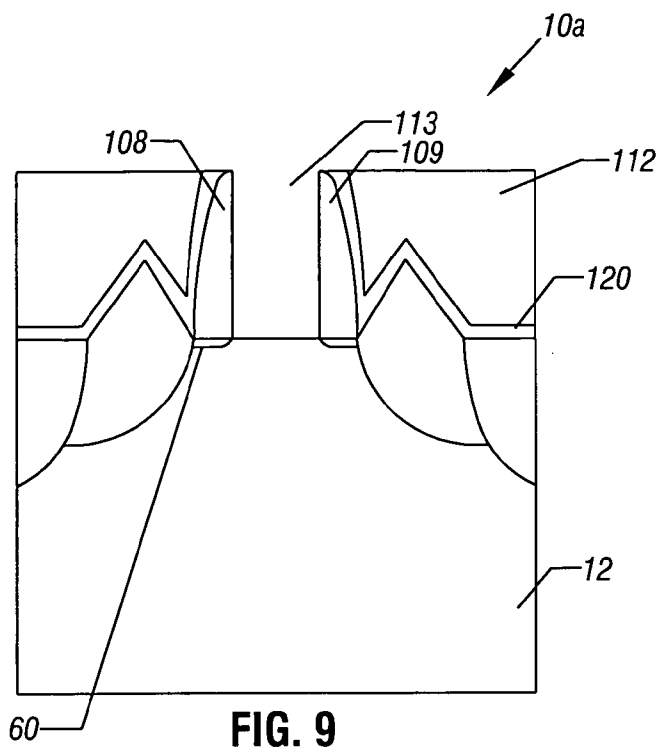

FIG. 9

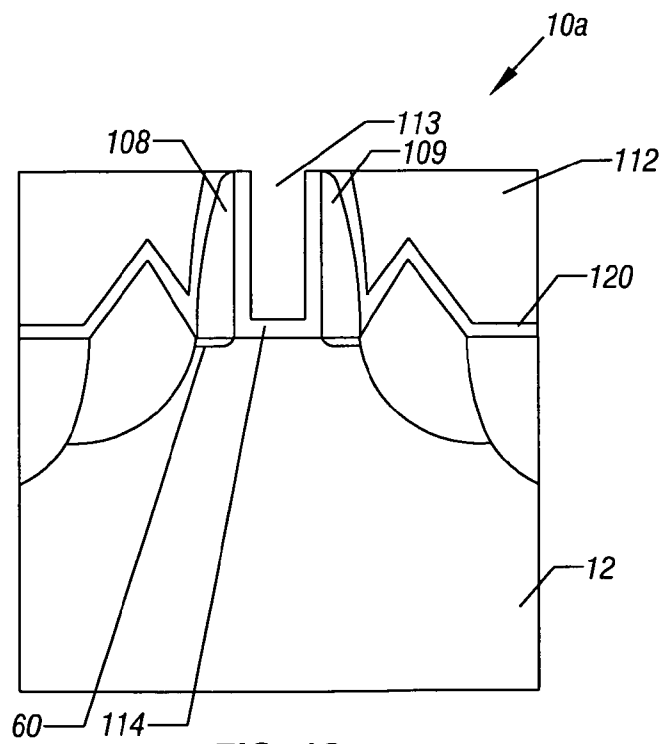
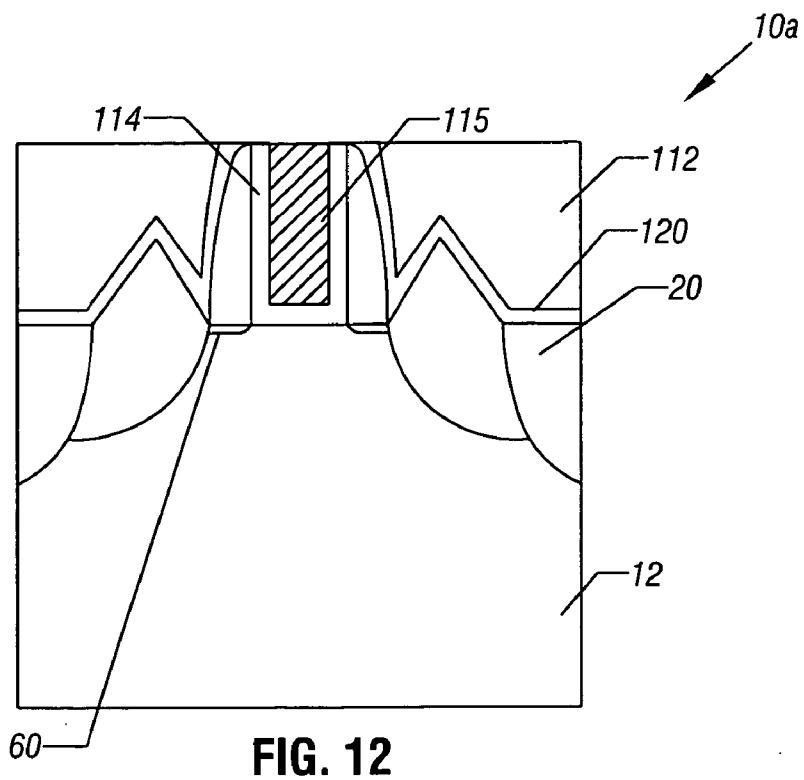
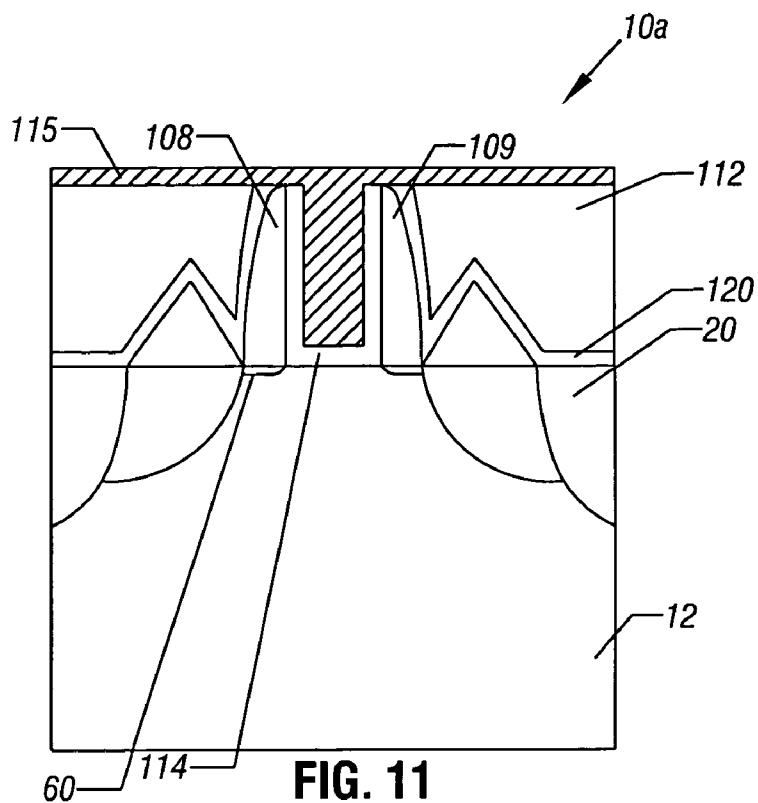

FIG. 10



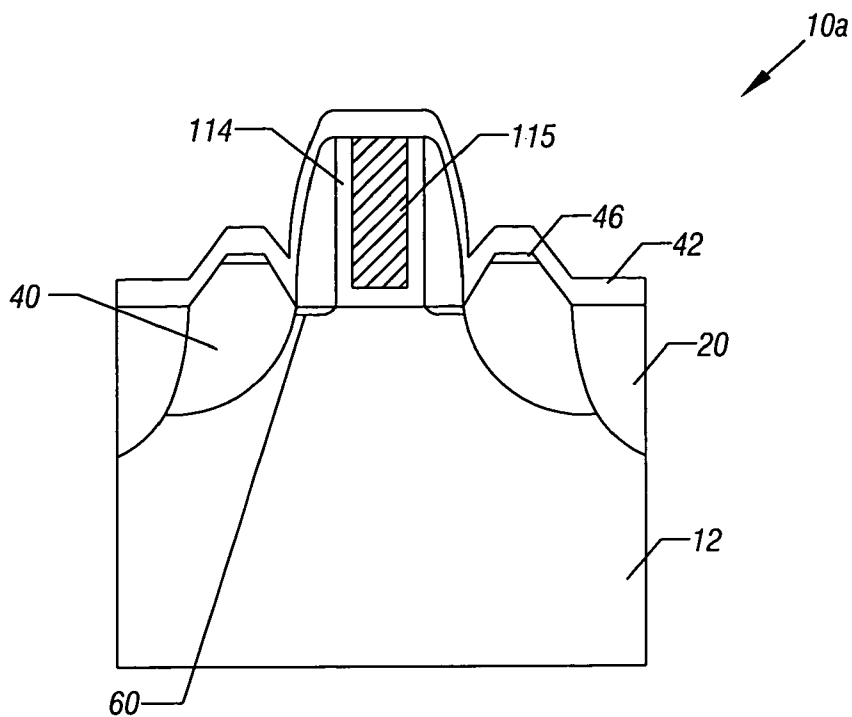

FIG. 13

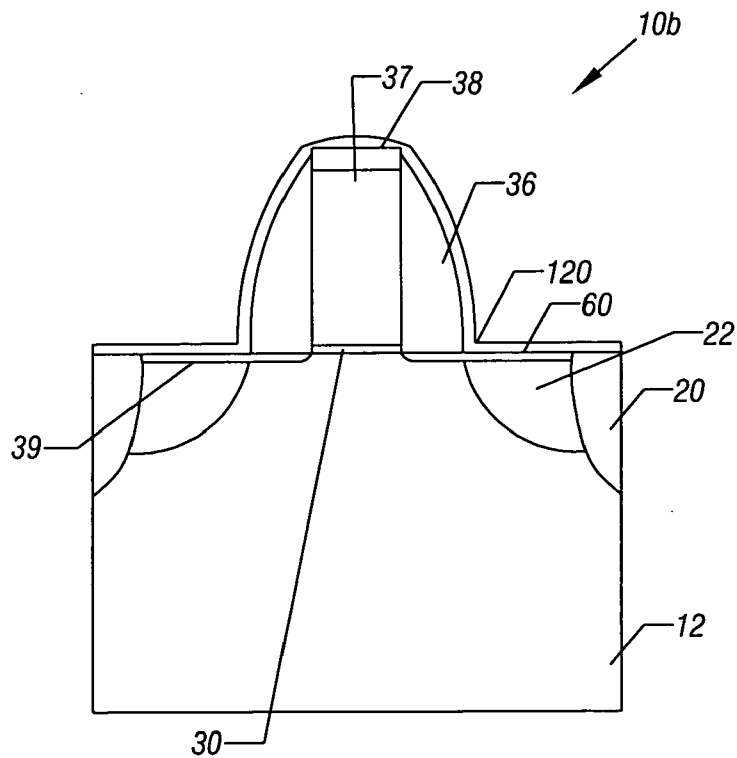

FIG. 14

COMPLEMENTARY METAL OXIDE SEMICONDUCTOR INTEGRATED CIRCUIT USING RAISED SOURCE DRAIN AND REPLACEMENT METAL GATE

BACKGROUND This invention relates generally to the fabrication of integrated circuits.

[0001] To increase performance of NMOS and PMOS deep sub-micron transistors in CMOS technology, current state-of-the-art technology uses compressive stress in the channel of the PMOS transistors, and tensile stress in the case of NMOS transistors.

[0002] Existing technologies that use strained channels are subject to a number of limitations. For example, polysilicon depletion may occur in the PMOS devices. In addition, tensile strain may arise in the PMOS devices. Remaining tensile strain degrades hole mobility in the PMOS devices.

[0003] Thus, there is a need for a better complementary metal oxide semiconductor process and particularly one which improves the performance of PMOS devices.

BRIEF DESCRIPTION OF THE DRAWINGS

[0004] **FIG. 1** is an enlarged, cross-sectional view of an PMOS transistor at an early stage of manufacture;

[0005] **FIG. 2** is an enlarged, cross-sectional view of a PMOS transistor at a subsequent stage of manufacture;

[0006] **FIG. 3** is an enlarged, cross-sectional view at a stage subsequent to the stage shown in **FIG. 2** in accordance with one embodiment of the present invention;

[0007] **FIG. 4** is an enlarged, cross-sectional view at a stage subsequent to the stage shown in **FIG. 3** in accordance with one embodiment of the present invention;

[0008] **FIG. 5** is an enlarged, cross-sectional view at a stage subsequent to the stage shown in **FIG. 4** in accordance with one embodiment of the present invention;

[0009] **FIG. 6** is an enlarged, cross-sectional view at a stage subsequent to the stage shown in **FIG. 5** in accordance with one embodiment of the present invention;

[0010] **FIG. 7** is an enlarged, cross-sectional view at a stage subsequent to the stage shown in **FIG. 6** in accordance with one embodiment of the present invention;

[0011] **FIG. 8** is an enlarged, cross-sectional view at a stage subsequent to the stage shown in **FIG. 7** in accordance with one embodiment of the present invention;

[0012] **FIG. 9** is an enlarged, cross-sectional view at a stage subsequent to the stage shown in **FIG. 8** in accordance with one embodiment of the present invention;

[0013] **FIG. 10** is an enlarged, cross-sectional view at a stage subsequent to the stage shown in **FIG. 9** in accordance with one embodiment of the present invention;

[0014] **FIG. 11** is an enlarged, cross-sectional view at a stage subsequent to the stage shown in **FIG. 10** in accordance with one embodiment of the present invention;

[0015] **FIG. 12** is an enlarged, cross-sectional view at a stage subsequent to the stage shown in **FIG. 11** in accordance with one embodiment of the present invention;

[0016] **FIG. 13** is an enlarged, cross-sectional view at a stage subsequent to the stage shown in **FIG. 12** in accordance with one embodiment of the present invention; and

[0017] **FIG. 14** is a depiction of one embodiment of an NMOS transistor for use with the PMOS transistor shown in **FIG. 13** in accordance with one embodiment of the present invention.

DETAILED DESCRIPTION

[0018] The fabrication of the PMOS transistor of a complementary pair proceeds as shown in **FIGS. 1-13**. On both the NMOS and PMOS sides a silicon dioxide gate oxide **105** may be deposited in one embodiment. The gate oxide **105** may be covered by a gate material **104**, such as polysilicon, in turn covered by a hard mask **130** for patterning. Then the gate material **104** and gate dielectric **105**, such as oxide, are patterned to generate the **FIG. 1** structure on the PMOS side **10a**. The gate dielectric may be about 15 Angstroms thick and may be thermally grown in one embodiment.

[0019] Substrate **100** may comprise a bulk silicon or silicon-on-insulator substructure. Alternatively, substrate **100** may comprise other materials—which may or may not be combined with silicon—such as: germanium, indium antimonide, lead telluride, indium arsenide, indium phosphide, gallium arsenide, or gallium antimonide. Although a few examples of materials from which substrate **100** may be formed are described here, any material that may serve as a foundation upon which a semiconductor device may be built falls within the spirit and scope of the present invention. Shallow trench isolation region **20** may comprise silicon dioxide, or other materials that may separate the transistor's active regions.

[0020] Gate material **104** may comprise polysilicon and may, for example, be between about 100 and about 2,000 Angstroms thick and between about 500 and about 1,600 Angstroms thick in one embodiment. Hard mask **130** may comprise silicon nitride and may, for example, be between about 100 and about 500 Angstroms thick and between about 200 and about 350 Angstroms thick in one embodiment.

[0021] A tip or lightly doped source drain **60** may be formed using the gate structure as a mask. Ion implantation may be used to form the source drain **60**.

[0022] When gate material **104** comprises polysilicon, and hard mask **130** comprises silicon nitride, the **FIG. 1** structure may be made in the following way. A dummy dielectric layer, which may comprise silicon dioxide, is formed on substrate **100** (e.g., via a conventional thermal growth process), followed by forming a polysilicon layer on the dielectric layer (e.g., via a conventional deposition process). Using conventional deposition techniques, a silicon nitride layer is formed on the polysilicon layer. The silicon nitride, polysilicon, and dummy dielectric layers are then patterned to form patterned silicon nitride layer, patterned polysilicon layer, and patterned dielectric layer. When the dielectric layer comprises silicon dioxide, one may apply routine etch processes to pattern the polysilicon and dummy dielectric layers.

[0023] A nitride spacer material **134** may be deposited (**FIG. 2**) and anisotropically etched to form sidewall spacers

108, 109, shown in **FIG. 3**. The spacers **108, 109** may be on the order of 1000 Angstroms thick.

[0024] A trench **24** is formed into the substrate **100**, as shown in **FIG. 4**. The trench **24** may be formed by reactive ion etching using SF_6 chemistry. The etching is constrained by the isolation **20** on one side and, in one embodiment, does not substantially isotropically undercut the gate structure on the other side. As a result, an isotropic etch profile may be achieved on the inward edges of the trench **24** as shown in **FIG. 4**, while leaving a portion of the lightly doped source drain **60**. During this step the NMOS side **10b** may be covered by an oxide mask (not shown).

[0025] Then, an epitaxial silicon germanium source drain **40** may be grown which fills the trench **24** and extends thereabove as indicated at **FIG. 5**. The trench **24** may be filled using silicon germanium having 10-40 atomic percent germanium. Source drain doping may be done by in-situ doping using a diborane source. The epitaxial source drain **40** only grows in the trench **24** because all other material is masked or covered. The source drain **40** is raised and continues to grow until the facets meet. A source drain implant may be used thereafter in some embodiments.

[0026] As is shown in **FIG. 6**, after the masking of the NMOS side is removed, the structure of **FIG. 3** may be covered by an insulating layer **112**, such as a low dielectric constant material such as oxide and a nitride etch stop layer (NESL) **120**. The layer **112** may be doped with phosphorus, boron, or other materials and may be formed by high density plasma deposition. The layer **112** may then be planarized down to the upper surface of the gate material **104** thereby removing the hard mask **130** and the NESL **120**, as shown in **FIG. 7**. The layer **120** may be nitride. It helps the NMOS side by acting as an etch stop and a tensile layer, but may degrade the PMOS side **10a** by producing-strain. Thus, removing the NESL **120** on the PMOS side **10a** may improve performance.

[0027] As is shown in **FIG. 8**, the gate material **104** may be removed to form a trench **113** over the remaining gate oxide **105**. Removal of the gate material **104** may be done, for example, by any of a variety of techniques including selective etching of the gate material **104** relative to the gate material of the NMOS transistor or shielding the NMOS transistor during the process shown in **FIG. 8**.

[0028] Gate material **104** is removed to generate trench **113** that is positioned between sidewall spacers **108, 109**—producing the structure shown in **FIG. 8**. In one embodiment, a wet etch process that is selective for material **104** over the corresponding material of the NMOS transistor (not shown) may be applied to remove material **104** without removing significant portions of NMOS material.

[0029] The layer **104** may be selectively removed in some embodiments. In one embodiment, layer **104** is exposed to a solution that comprises between about 20 and about 30 percent tetramethyl ammonium hydroxide (TMAH) by volume in deionized water for a sufficient time at a sufficient temperature (e.g., between about 60° C. and about 90° C.), while applying sonic energy, to remove all of layer **106** without removing significant portions of any NMOS transistor structure (not shown).

[0030] Alternatively, a dry etch process may be applied to selectively remove layer **104**. When gate layer **104** is doped

p-type (e.g., with boron), such a dry etch process may comprise exposing sacrificial gate electrode layer **104** to a plasma derived from sulfur hexafluoride (“ SF_6 ”), hydrogen bromide (“HBr”), hydrogen iodide (“HI”), chlorine, argon, and/or helium. Such a selective dry etch process may take place in a parallel plate reactor or in an electron cyclotron resonance etcher.

[0031] After removing material **104**, dielectric layer **105** is removed. When dielectric layer **105** comprises silicon dioxide, it may be removed using an etch process that is selective for silicon dioxide to generate the **FIG. 9** structure. Such etch processes include: exposing layer **105** to a solution that includes about 1 percent hydrofluoric acid (HF) in deionized water, or applying a dry etch process that employs a fluorocarbon based plasma. Layer **105** may be exposed for a limited time, as the etch process for removing layer **105** may also remove part of dielectric layer **112**. With that in mind, if a 1 percent HF based solution is used to remove layer **105**, the device may be exposed to that solution for less than about 60 seconds, for example for about 30 seconds or less. It may be possible to remove layer **105** without removing a significant amount of dielectric layer **112**, if layer **105** is less than about 30 Angstroms thick, when initially deposited.

[0032] Next, a new gate dielectric **114** may be deposited and planarized to have a u-shape, lining the opening **113**, as shown in **FIG. 10**. Although gate dielectric layer **114** may comprise any material that may serve as a gate dielectric for a PMOS transistor that includes a metal gate electrode, gate dielectric layer **114** may comprise a high dielectric constant (k) metal oxide dielectric material which has a dielectric constant greater than ten. Some of the materials that may be used to make high-k gate dielectric **114** include: hafnium oxide, hafnium silicon oxide, lanthanum oxide, zirconium oxide, zirconium silicon oxide, tantalum oxide, titanium oxide, barium strontium titanium oxide, barium titanium oxide, strontium titanium oxide, yttrium oxide, aluminum oxide, lead scandium tantalum oxide, and lead zinc niobate. Particularly useful metal oxides include hafnium oxide, zirconium oxide, and aluminum oxide. Although a few examples of metal oxides that may be used to form high-k gate dielectric layer **114** are described here, that layer may be made from other metal oxides as well.

[0033] High-k gate dielectric layer **114** may be formed on substrate **100** using a conventional deposition method, e.g., a conventional chemical vapor deposition (“CVD”), low pressure CVD, or physical vapor deposition (“PVD”) process. Preferably, a conventional atomic layer CVD process is used. In such a process, a metal oxide precursor (e.g., a metal chloride) and steam may be fed at selected flow rates into a CVD reactor, which is then operated at a selected temperature and pressure to generate an atomically smooth interface between substrate **100** and high-k gate dielectric layer **114**. The CVD reactor should be operated long enough to form a layer with the desired thickness. In most applications, high-k gate dielectric layer **114** may, for example, be less than about 60 Angstroms thick and, in one embodiment, between about 5 Angstroms and about 40 Angstroms thick.

[0034] When an atomic layer CVD process is used to form high-k gate dielectric layer **114**, that layer will form on the vertical sides of trench **113** in addition to forming on the bottom of that trench. If high-k gate dielectric layer **114** comprises an oxide, it may manifest oxygen vacancies at

random surface sites and unacceptable impurity levels, depending upon the process used to make it. It may be desirable to remove impurities from layer **114**, and to oxidize it to generate a layer with a nearly idealized metal:oxygen stoichiometry, after layer **114** is deposited.

[0035] To remove impurities from that layer and to increase that layer's oxygen content, a wet chemical treatment may be applied to high-k gate dielectric layer **114**. Such a wet chemical treatment may comprise exposing high-k gate dielectric layer **114** to a solution that comprises hydrogen peroxide at a sufficient temperature for a sufficient time to remove impurities from high-k gate dielectric layer **114** and to increase the oxygen content of high-k gate dielectric layer **114**. The appropriate time and temperature at which high-k gate dielectric layer **114** is exposed may depend upon the desired thickness and other properties for high-k gate dielectric layer **114**.

[0036] When high-k gate dielectric layer **114** is exposed to a hydrogen peroxide based solution, an aqueous solution that contains between about 2% and about 30% hydrogen peroxide by volume may be used. That exposure step may take place at between about 15° C. and about 40° C. for at least about one minute. In a particularly preferred embodiment, high-k gate dielectric layer **114** is exposed to an aqueous solution that contains about 6.7% H₂O₂ by volume for about 10 minutes at a temperature of about 25° C. During that exposure step, it may be desirable to apply sonic energy at a frequency of between about 10 KHz and about 2,000 KHz, while dissipating at between about 1 and about 10 Watts/cm². In one embodiment, sonic energy may be applied at a frequency of about 1,000 KHz, while dissipating at about 5 Watts/cm².

[0037] A gate metal **115** may be deposited into the trench **113**, overlapping the insulating material **112**, as shown in **FIG. 11**. The gate metal may be planarized to form a metal gate electrode **115** shown in **FIG. 12**.

[0038] The p-type metal layer **115** may fill trench **113** to generate. P-type metal layer **115** may comprise any p-type conductive material from which a metal PMOS gate electrode may be derived and which compressively strains the channel to this end. The p-type metal layer may be one with a higher coefficient of thermal expansion than that of the substrate **100**, which may be silicon. Examples of suitable metals includes boron carbide, tungsten, molybdenum, rhodium, vanadium, platinum, ruthenium, beryllium, palladium, cobalt, titanium, nickel, copper, tin, aluminum, lead, zinc, alloys, and silicides of these materials. In one embodiment, the use of a material having a coefficient of thermal expansion higher than that of tungsten (0.4×10^{-5} in./in./° C.) is advantageous. A relatively high deposition temperature, such as 400° C., may be used in some embodiments, generating compressive strain in the channel and improving mobility. P-type metal layer **115** preferably has thermal stability characteristics that render it suitable for making a metal PMOS gate electrode for a semiconductor device.

[0039] Materials that may be used to form p-type metal layer **115** include: ruthenium, palladium, platinum, cobalt, nickel, and conductive metal oxides, e.g., ruthenium oxide. The metal of the layer **115** may be the same or different than the metal component of the metal oxide dielectric layer **105**. P-type metal layer **115** may be formed on gate dielectric layer **105** using well known PVD or CVD processes, e.g.,

conventional sputter or atomic layer CVD processes. P-type metal layer **115** is removed except where it fills trench **113**. Layer **115** may be removed from other portions of the device via a wet or dry etch process, or an appropriate CMP operation, with dielectric **112** serving as an etch or polish stop.

[0040] The p-type metal layer **115** may compensate for a threshold voltage shift due to the silicon germanium raised source drain **40**. The workfunction of the metal layer **115** may be adjusted or selected so as to compensate for the threshold voltage shift that necessarily results from using the raised source drain **40**. Generally, the raised source drain **40** causes the valence to go up, and to lower the threshold voltage. Thus, it may be desired to use a mid-gap metal as the layer **115**, whose workfunction may compensate for the threshold voltage shift.

[0041] P-type metal layer **115** may serve as a metal PMOS gate electrode with a workfunction that is between about 4.9 eV and about 5.2 eV, and that may, for example, be between about 10 Angstroms and about 2,000 Angstroms thick and, in one embodiment, is between about 500 Angstroms and about 1,600 Angstroms thick.

[0042] The structure shown in **FIG. 13** may then be completed by forming silicide contacts **46**, and the nitride etch stop layer **42**. The nitride etch stop layer **42** may be provided after the contacts **46** have been formed.

[0043] In some embodiments of the present invention, the epitaxial silicon germanium raised source drains **40** compressively strain the PMOS channel to improve mobility and reduce external resistance. This may be achieved, in some embodiments, by in-situ boron doping the source drain regions **40**, lowering the Schottky energy barrier for hole injection, thereby improving contact resistance.

[0044] The replacement metal gate process may reduce polysilicon depletion while synergistically relieving tensile strain in the PMOS device during the polysilicon opening polish (**FIG. 7**) and/or the etch of the nitride etch stop layer **42** used in forming the contacts. The PMOS device may benefit by reducing tensile strain that degrades hole mobility.

[0045] The replacement metal gate electrode **115** may be tuned for the PMOS transistor with or without using high dielectric constant (greater than 10) dielectrics or the gate dielectric **114** for eliminating polysilicon depletion and reducing gate leakage. A polish and/or removal of the tensile strained NESL **120** over the PMOS device **10a** during the replacement metal gate flow may improve PMOS mobility.

[0046] The fabrication of the NMOS transistor **10b**, shown in **FIG. 14**, proceeds according to a conventional technology. For example, the NMOS transistor **10b** may have a graded junction including a shallow tip/source/drain **39** and a deep source drain **22** which may be made by ion implantation. In some embodiments strain may or may not be introduced. In some embodiments, the gate **37** is a replacement metal gate and in other embodiments, a convention polysilicon gate may be utilized. The gate **37** may be covered by the silicide contact **38**. The NESL **120** may be retained on the NMOS side **10b**.

[0047] While the present invention has been described with respect to a limited number of embodiments, those skilled in the art will appreciate numerous modifications and

variations therefrom. It is intended that the appended claims cover all such modifications and variations as fall within the true spirit and scope of this present invention.

What is claimed is:

- 1. A method comprising:
forming a replacement metal gate; and
forming a raised p-type source drain.
- 2. The method of claim 1 including forming a gate dielectric having a dielectric constant greater than 10.
- 3. The method of claim 1 including forming a dummy polysilicon gate electrode, selectively removing said dummy polysilicon gate electrode, and replacing said dummy polysilicon gate electrode with a metal gate electrode.
- 4. The method of claim 1 including forming a nitride etch stop layer over said dummy polysilicon gate electrode.
- 5. The method of claim 4 including removing said nitride etch stop layer over the PMOS side of a complementary structure.
- 6. The method of claim 5 including forming a U-shaped gate dielectric.
- 7. A semiconductor structure comprising:
a substrate having a raised p-type source drain; and
a metal gate electrode.
- 8. The structure of claim 7 wherein said raised source drain is formed of silicon and germanium.
- 9. The structure of claim 7 including a U-shaped gate electrode.
- 10. The structure of claim 7 including a gate electrode having a dielectric constant greater than 10.

- 11. A method comprising:
forming a dummy gate electrode;
covering said dummy gate electrode with a nitride etch stop layer;
removing said nitride etch stop layer;
removing said dummy electrode and replacing said dummy electrode with a metal gate electrode; and
forming an epitaxial p-type source drain.
- 12. The method of claim 11 including forming a raised source drain.
- 13. The method of claim 11 including forming a gate dielectric having a dielectric constant greater than 10.
- 14. The method of claim 11 including a U-shaped gate dielectric.
- 15. The method of claim 11 including forming said raised source drain of p-type doped silicon germanium.
- 16. The method of claim 11 including forming said nitride etch stop layer over a hard mask.
- 17. The method of claim 11 including forming said dummy gate electrode of polysilicon.
- 18. The method of claim 11 including forming a complementary metal oxide semiconductor integrated circuit.
- 19. The method of claim 11 including etching into a semiconductor substrate using the metal gate electrode as a mask and depositing a boron doped silicon germanium epitaxial material to form said p-type source drain.
- 20. The method of claim 11 including only removing a nitride etch stop layer from a PMOS structure while leaving the nitride etch stop layer on an NMOS structure.

* * * * *