



(19) **United States**

(12) **Patent Application Publication** (10) **Pub. No.: US 2006/0059606 A1**

Ferrara

(43) **Pub. Date: Mar. 23, 2006**

(54) **MULTILAYER AIR-CUSHION SHELL WITH ENERGY-ABSORBING LAYER FOR USE IN THE CONSTRUCTION OF PROTECTIVE HEADGEAR**

Publication Classification

(51) **Int. Cl.**
A42B 3/00 (2006.01)
(52) **U.S. Cl.** **2/412; 2/410**

(75) **Inventor: Vincent R. Ferrara, Wellesley, MA (US)**

(57) **ABSTRACT**

Correspondence Address:
CESARI AND MCKENNA, LLP
88 BLACK FALCON AVENUE
BOSTON, MA 02210 (US)

A multilayer shell for use in the construction of protective headgear, the shell including an outer layer, an inner layer, and a middle layer disposed between the outer and inner layer which resiliently compresses in response to an impact to the outer layer. The middle layer includes a plurality of compressible members, which resiliently compress to absorb the energy of a direct impact to the outer layer and resiliently shear with respect to the inner layer in response to a tangential impact to the outer layer. Each of the of compressible members may have bellows-like construction which forms a hollow chamber and includes a small opening through which air is expelled to produce a rate-sensitive response corresponding to the force of the impact. The shell may include one or more passageways to expel air from the middle layer into the interior of the headgear during and as a result of an impact.

(73) **Assignee: Xenith Athletics, Inc., Boston, MA**

(21) **Appl. No.: 11/059,427**

(22) **Filed: Feb. 16, 2005**

Related U.S. Application Data

(63) **Continuation-in-part of application No. 10/946,672, filed on Sep. 22, 2004.**

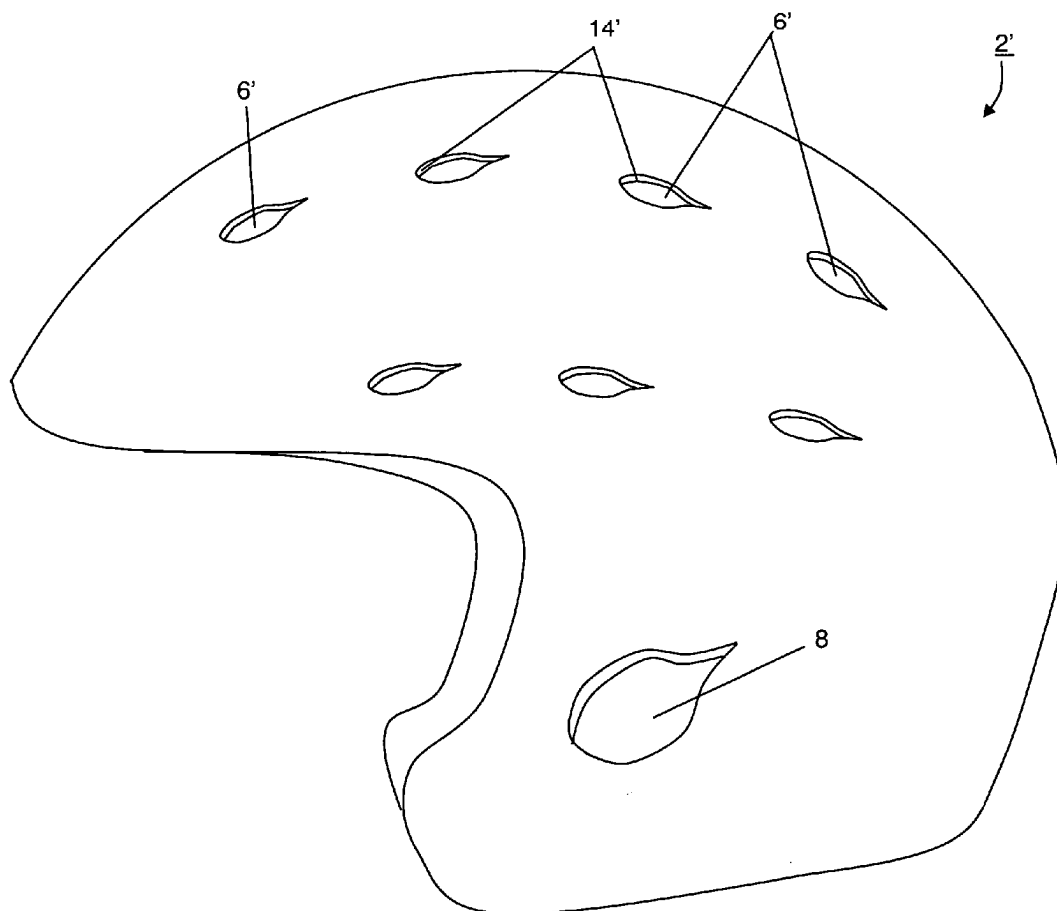

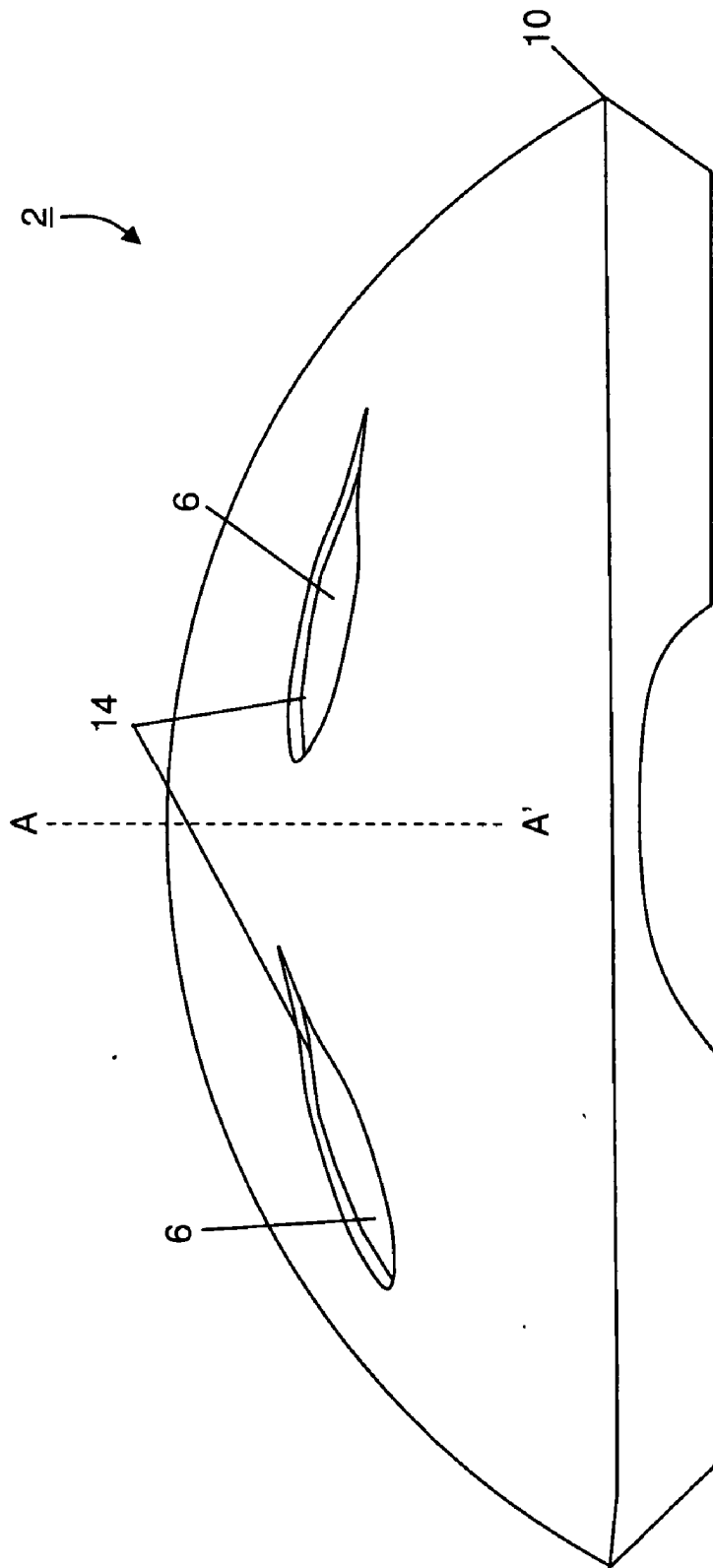

FIG. 1

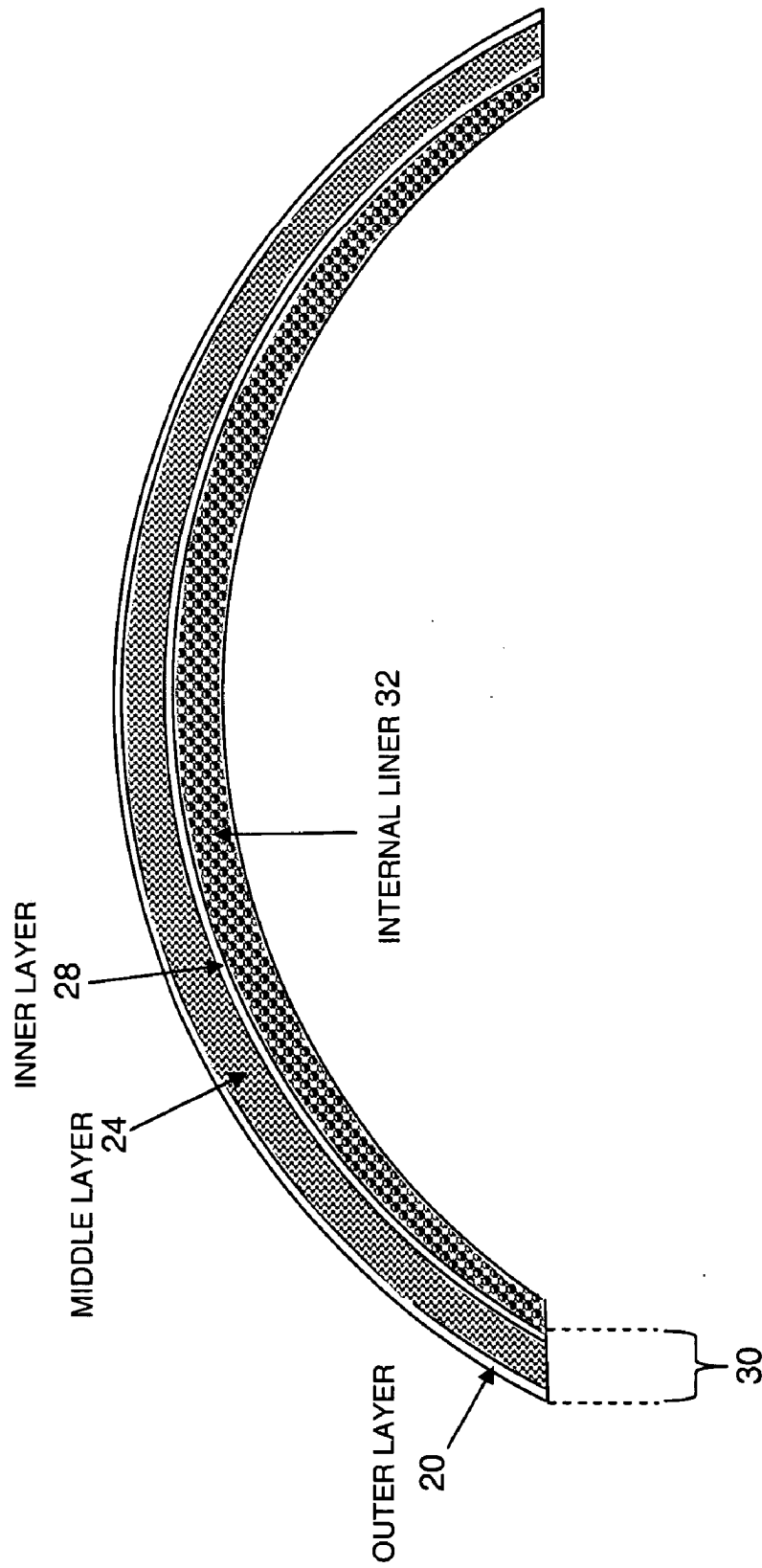

FIG. 2

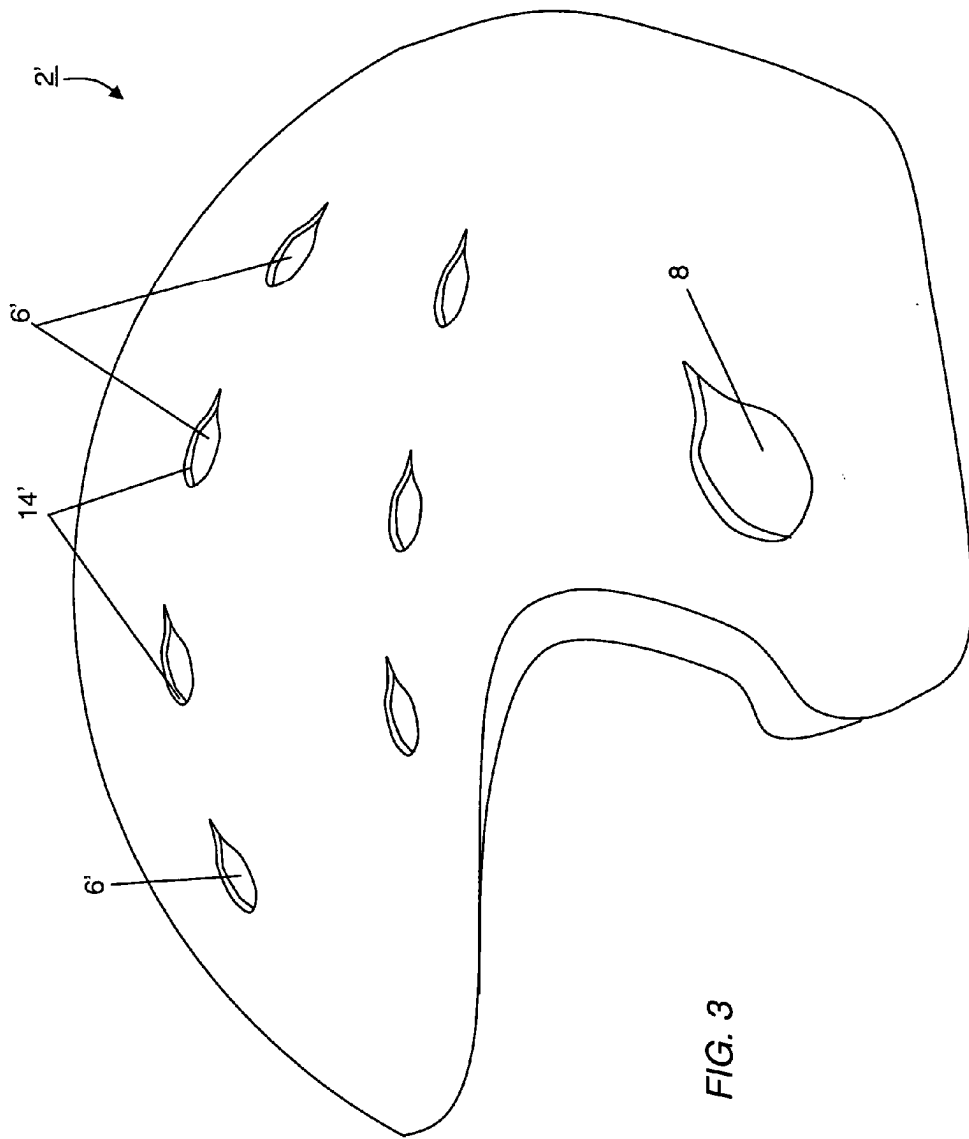

FIG. 3

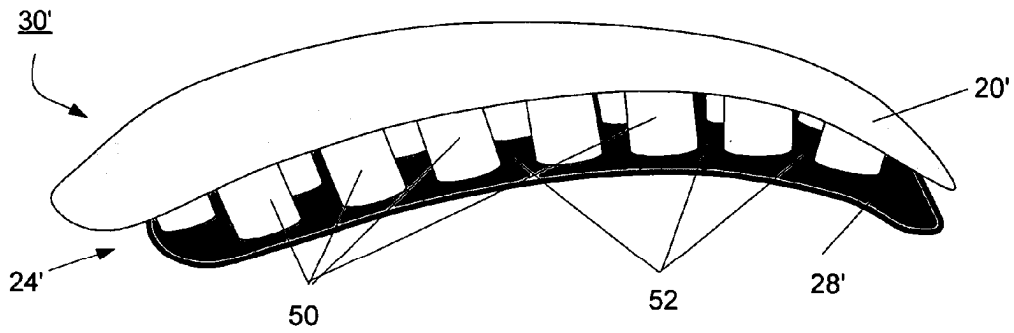

FIG. 4

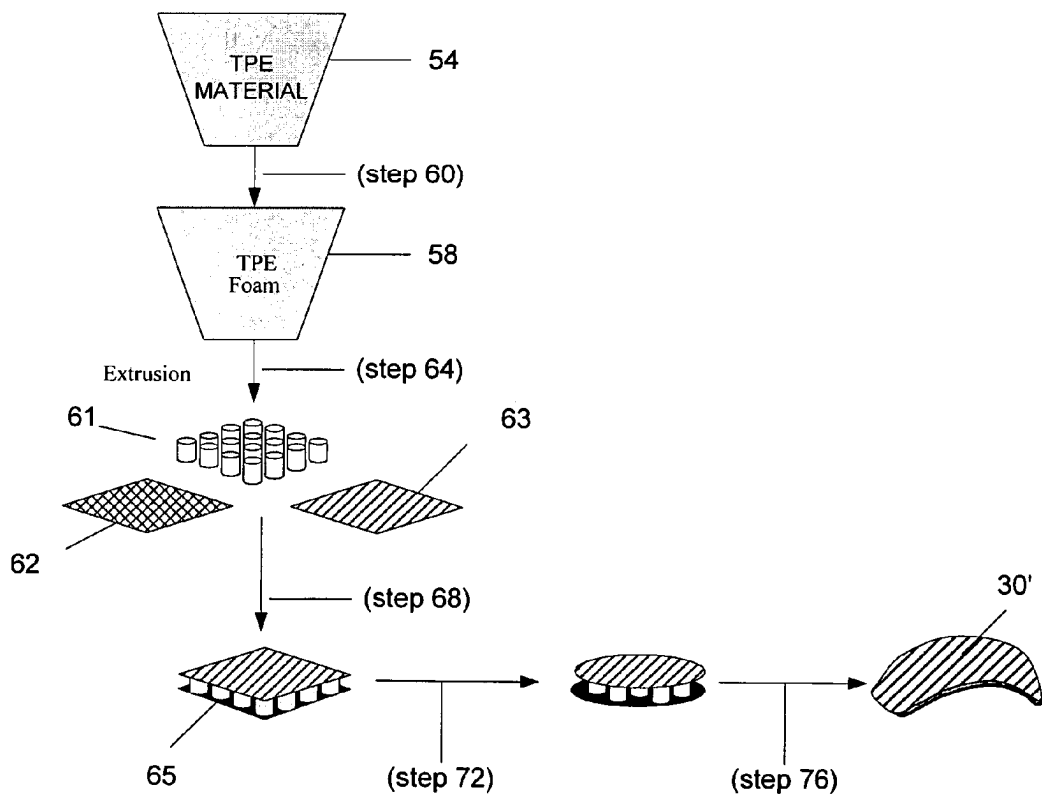

FIG. 5

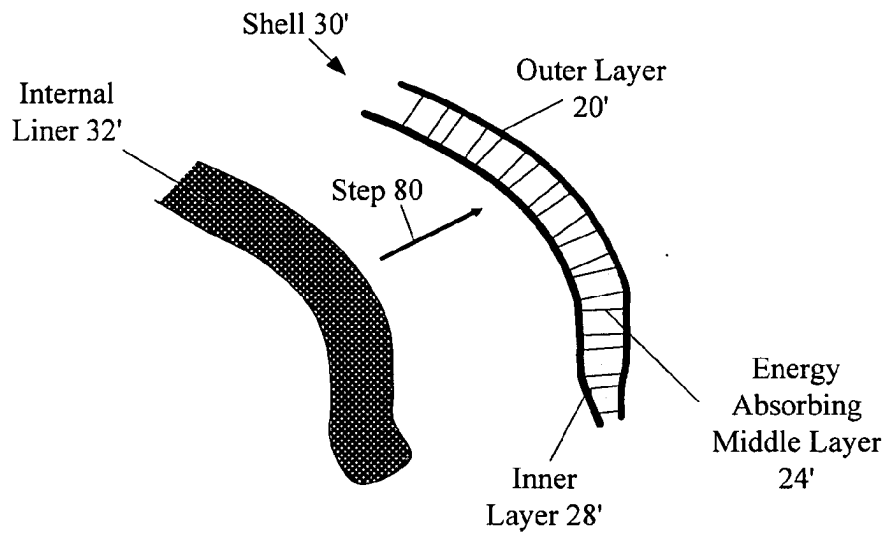
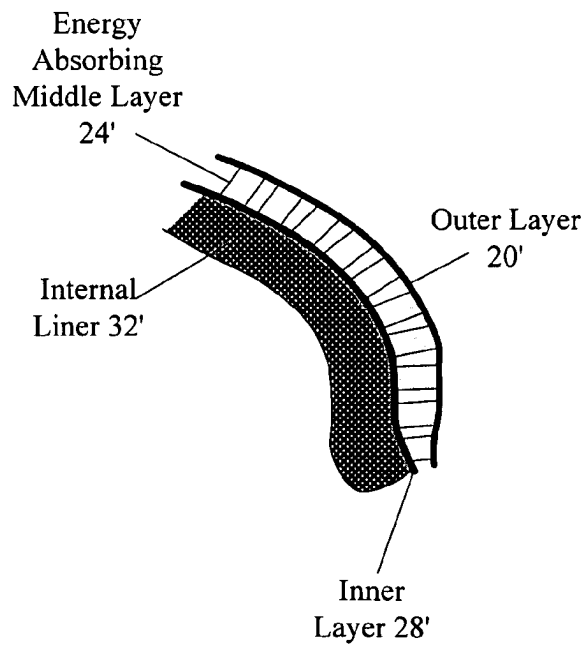

FIG. 6:



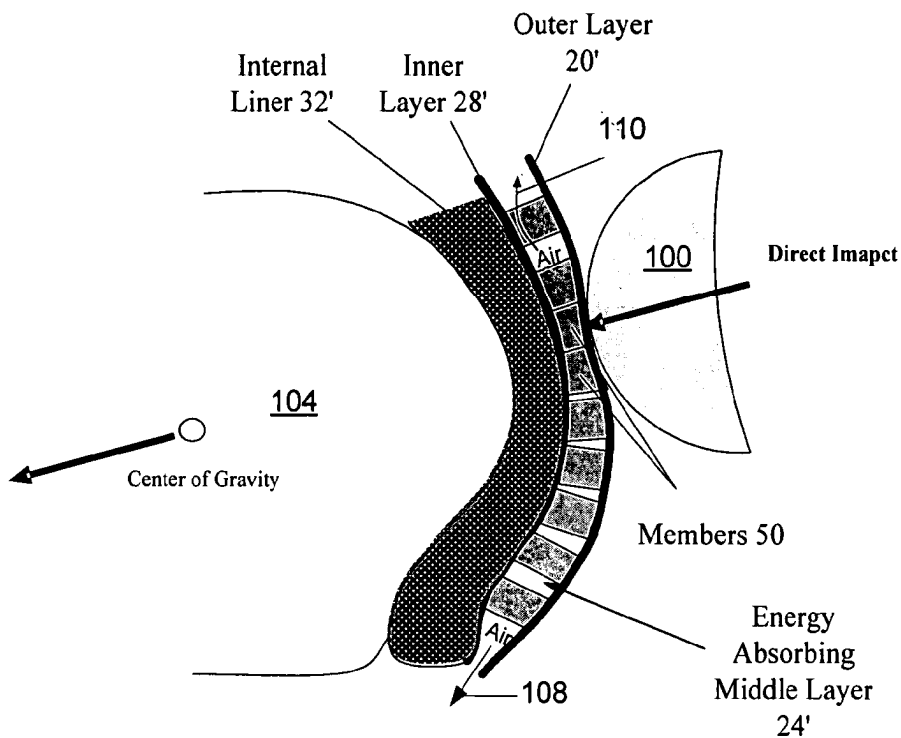

FIG. 7A

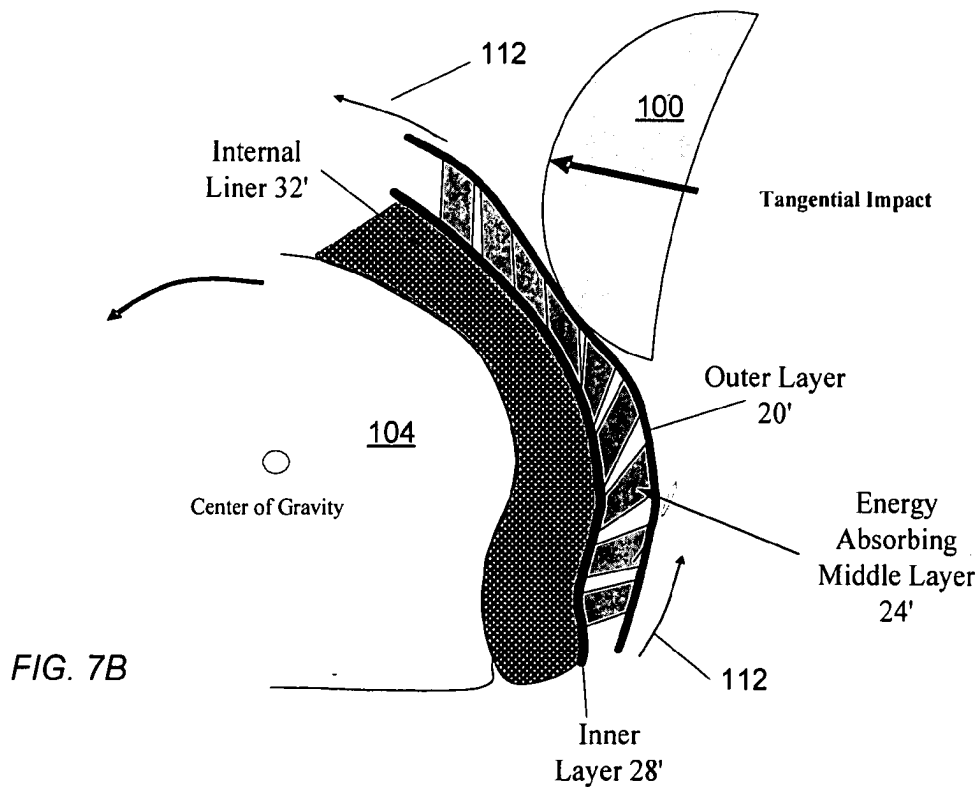
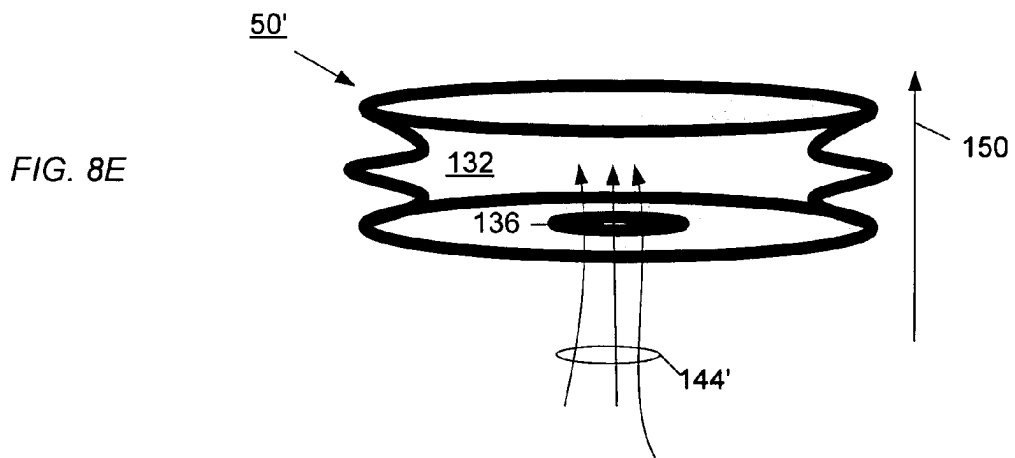
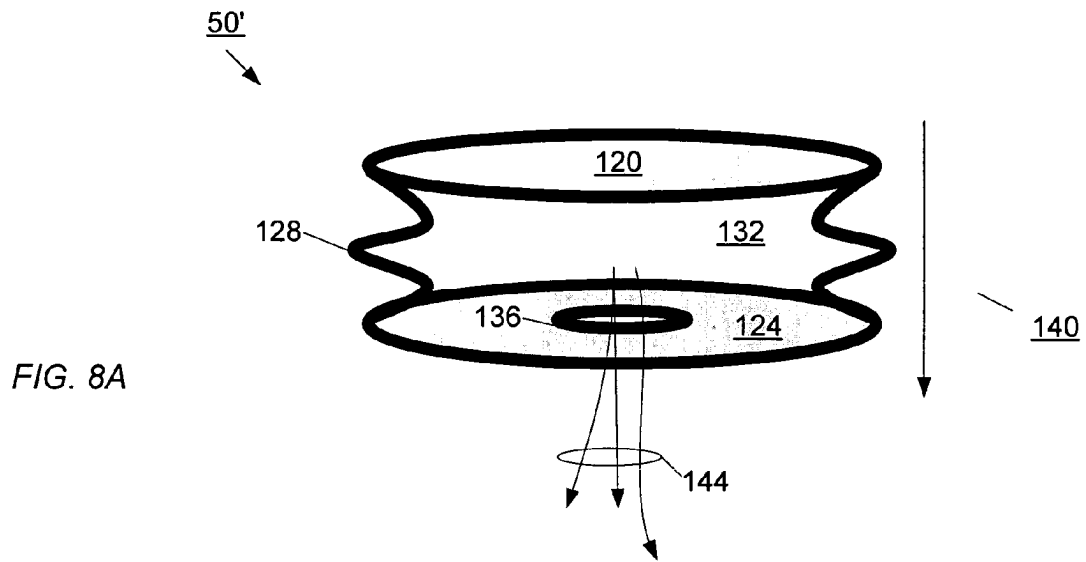

FIG. 7B



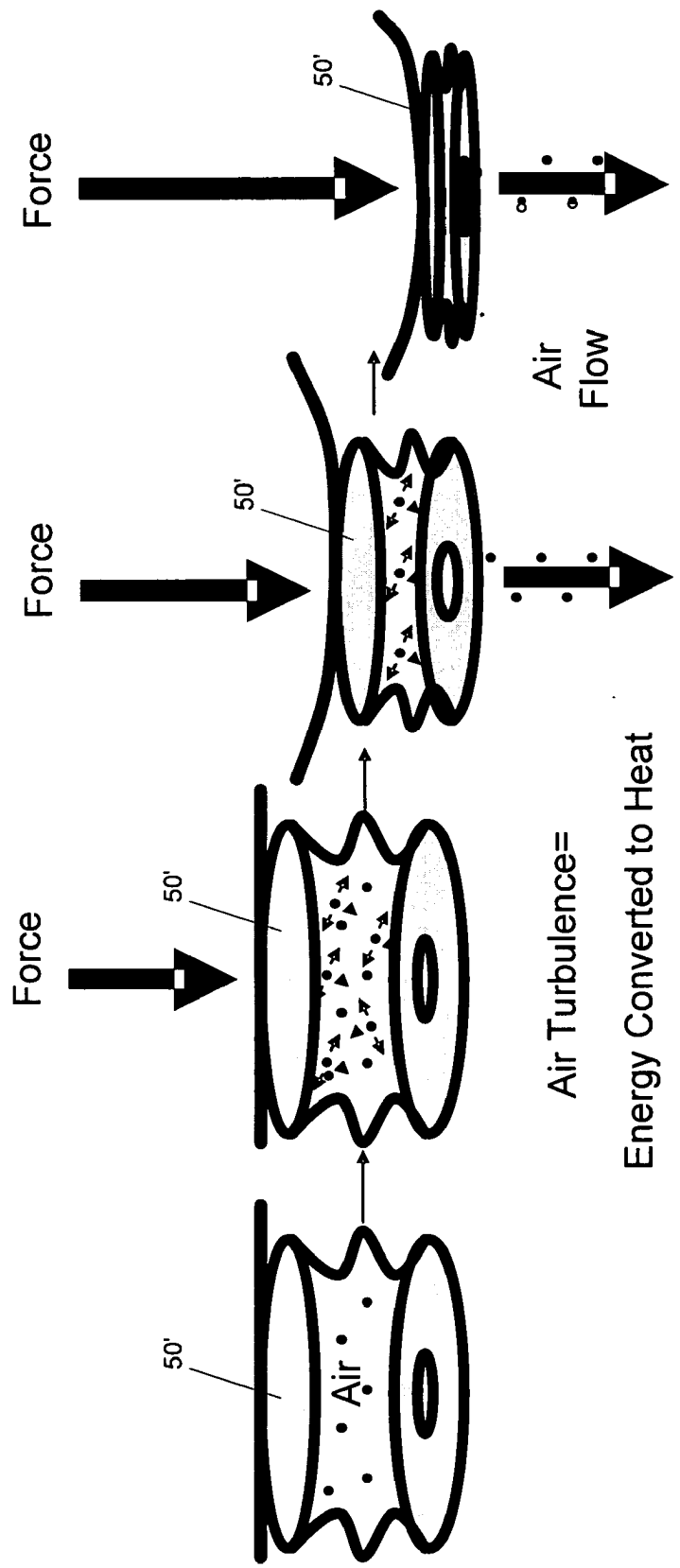

FIG. 8B



FIG. 8C

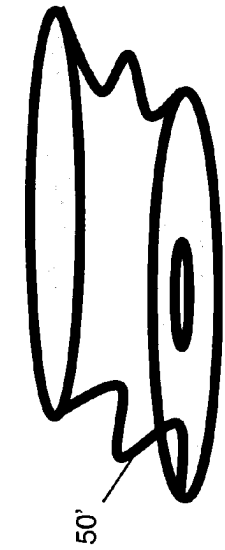
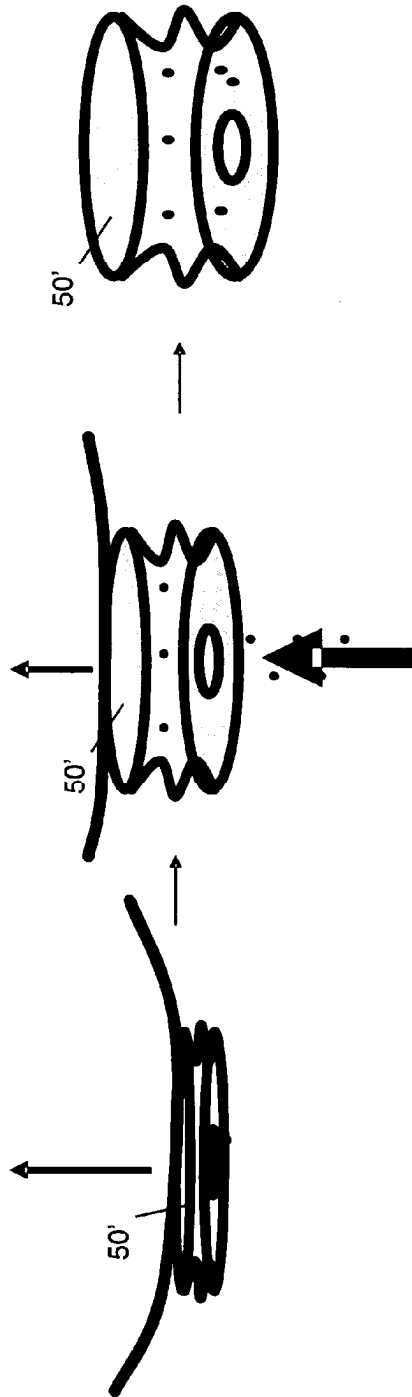

FIG. 8D



Air Refills

FIG. 8F

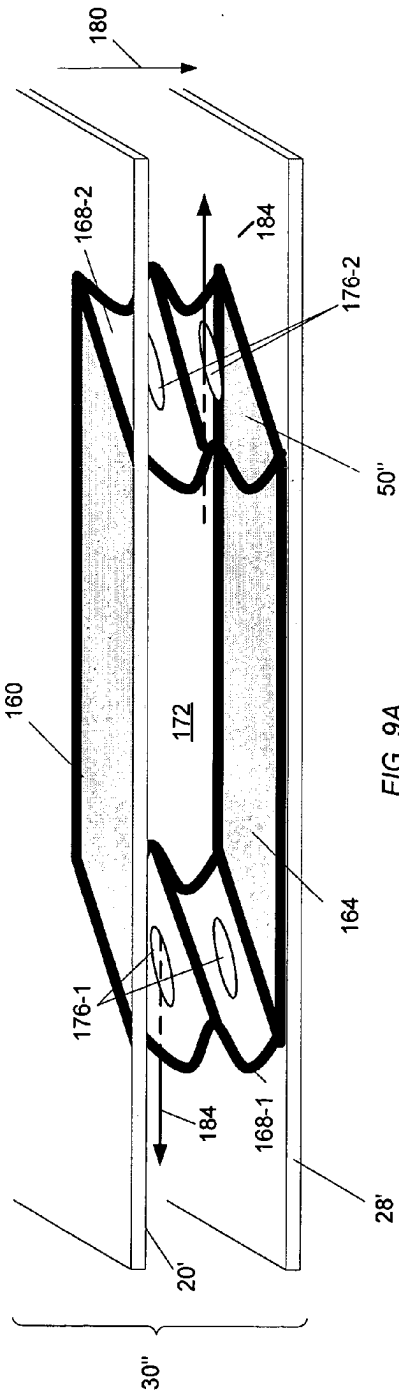

FIG. 9A

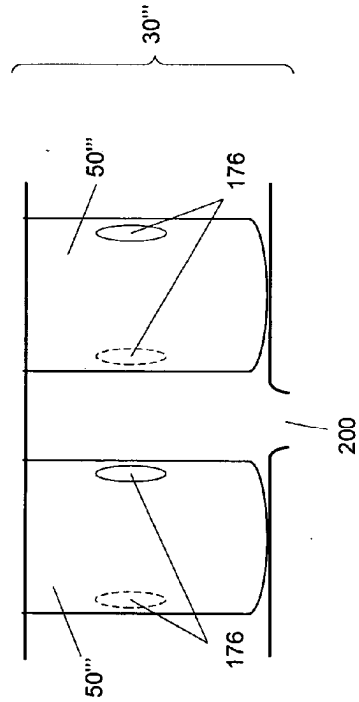

FIG. 9B

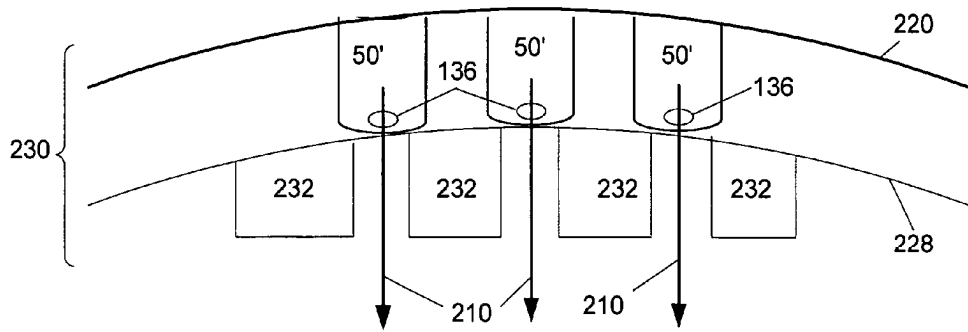

FIG. 10A

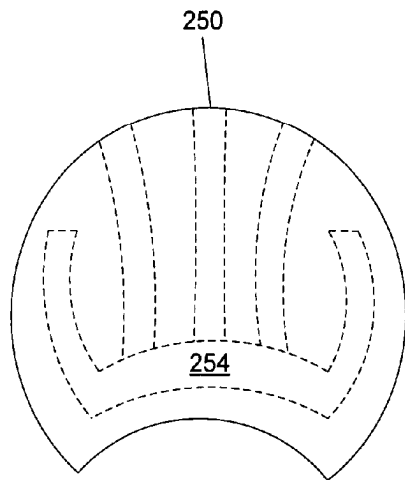

FIG. 11A

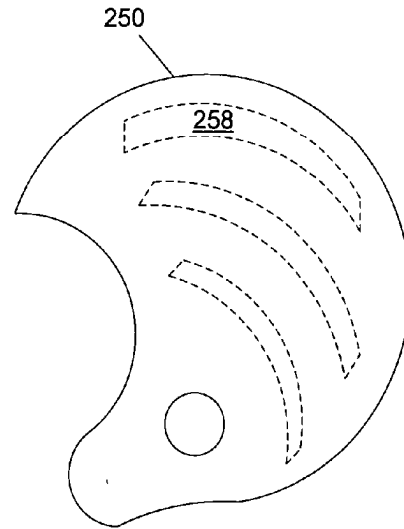

FIG. 11B

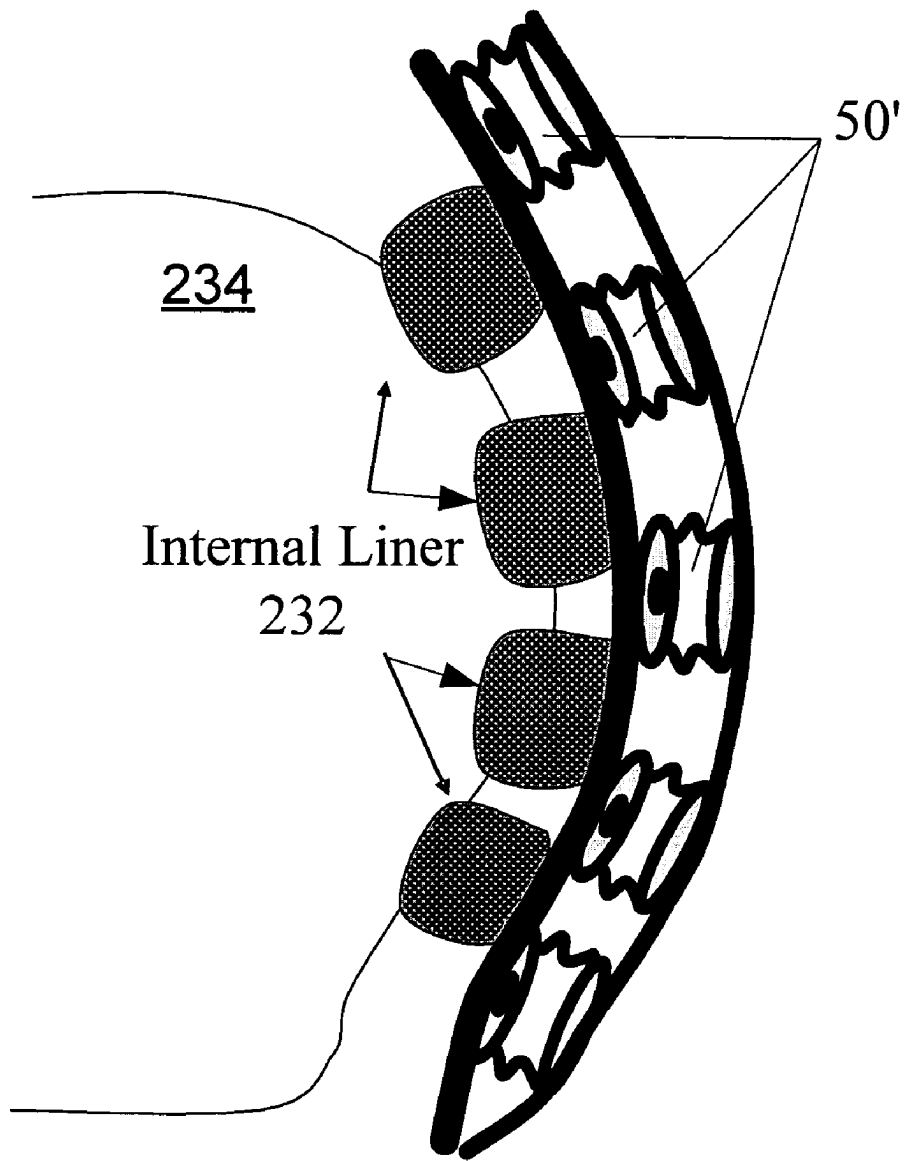

FIG. 10B

FIG. 10C

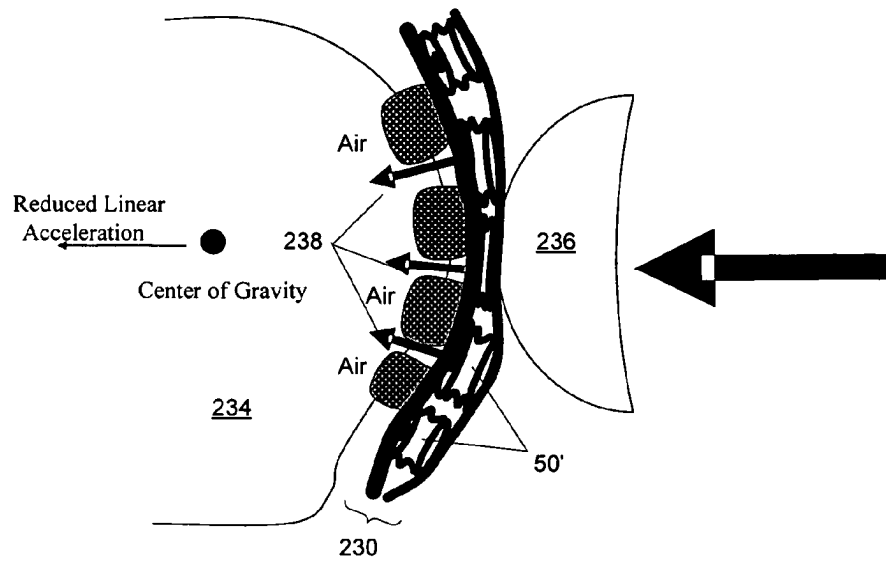
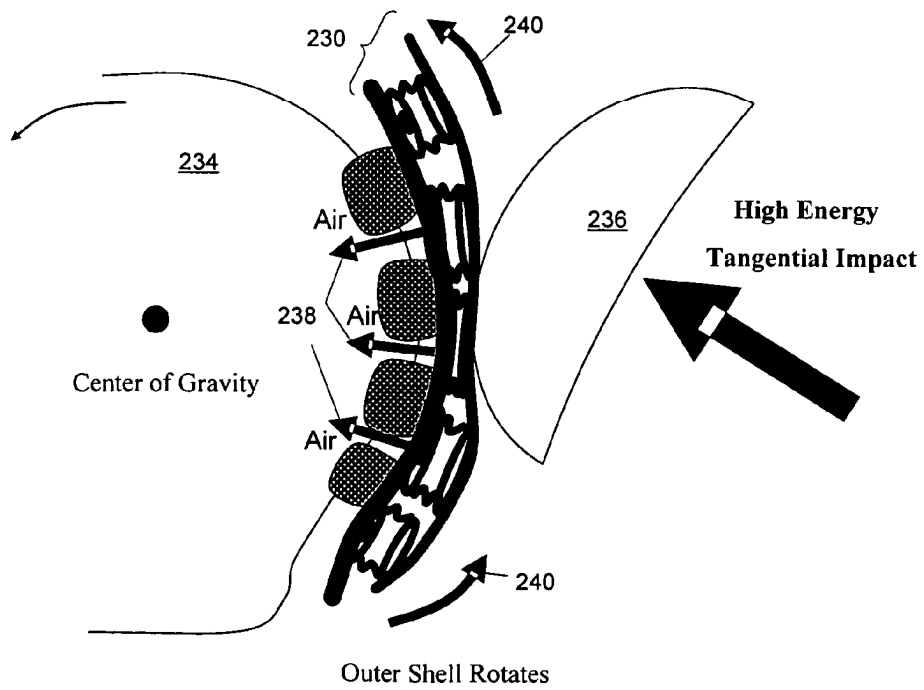

FIG. 10D



MULTILAYER AIR-CUSHION SHELL WITH ENERGY-ABSORBING LAYER FOR USE IN THE CONSTRUCTION OF PROTECTIVE HEADGEAR

RELATED APPLICATION

[0001] This application is a continuation-in-part application claiming priority to co-pending U.S. patent application Ser. No. 10/946,672, filed Sep. 22, 2004, titled "Layered Construction of Protective Headgear with one or More Compressible Layers of Thermoplastic Material," the entirety of which patent application is incorporated by reference herein.

FIELD OF THE INVENTION

[0002] The invention relates generally to protective headgear. More specifically, the invention relates to a layered construction of protective headgear using compressible materials.

BACKGROUND

[0003] Concussions, also called mild traumatic brain injury, are a common, serious problem in sports known to have detrimental effects on people in the short and long term. With respect to athletes, a concussion is a temporary and reversible neurological impairment, with or without loss of consciousness. Another definition for a concussion is a traumatically induced alteration of brain function manifested by 1) an alteration of awareness or consciousness, and 2) signs and symptoms commonly associated with post-concussion syndrome, such as persistent headaches, loss of balance, and memory disturbances, to list but a few. Some athletes have had their careers abbreviated because of concussions, in particular because those who have sustained multiple concussions show a greater proclivity to further concussions and increasingly severe symptoms. Although concussions are prevalent among athletes, the study of concussions is difficult, treatment options are virtually non-existent, and "return-to-play" guidelines are speculative. Accordingly, the best current solution to concussions is prevention and minimization.

[0004] Concussion results from a force being applied to the brain, usually the result of a direct blow to the head, which results in shearing force to the brain tissue, and a subsequent deleterious neurometabolic and neurophysiologic cascade. There are two primary types of forces experienced by the brain in an impact to the head, linear acceleration and rotational acceleration. Both types of acceleration are believed to be important in causing concussions. Decreasing the magnitude of acceleration thus decreases the force applied to the brain, and consequently reduces the risk or severity of a concussion.

[0005] Protective headgear is well known to help protect wearers from head injury by decreasing the magnitude of acceleration (or deceleration) experienced by their wearers. Currently marketed helmets, primarily address linear forces, but generally do not diminish the rotational forces experienced by the brain. Helmets fall generally into two categories: single-impact helmets and multiple-impact helmets. Single-impact helmets undergo permanent deformation under impact, whereas multiple-impact helmets are capable of sustaining multiple blows. Applications of single-impact helmets include, for example, bicycling and motorcycling.

Participants of contact sports, such as hockey and football, use multiple-impact helmets. Both categories of helmets have similar construction. A semi-rigid outer shell distributes the force of impact over a wide area and a crushable inner layer reduces the force upon the wearer's head.

[0006] The inner layer of single-impact helmets are typically constructed of fused expanded polystyrene (EPS), a polymer impregnated with a foaming agent. EPS reduces the amount of energy that reaches the head by permanently deforming under the force of impact. To be effective against the impact, the inner layer must be sufficiently thick not to crush entirely throughout its thickness. A thick inner layer, however, requires a corresponding increase in the size of the outer shell, which increases the size and bulkiness of the helmet.

[0007] Inner layers designed for multiple-impact helmets absorb energy through elastic and viscoelastic deformation. To absorb multiple successive hits, these helmets need to rebound quickly to return to their original shape. Materials that rebound too quickly, however, permit some of the kinetic energy of the impact to transfer to the wearer's head. Examples of materials with positive rebound properties, also called elastic memory, include foamed polyurethane, expanded polypropylene, expanded polyethylene, and foamed vinyl nitrile. Although some of these materials have desirable rebound qualities, an inner layer constructed therefrom must be sufficiently thick to prevent forceful impacts from penetrating its entire thickness. The drawback of a thick layer, as noted above, is the resulting bulkiness of the helmet. Moreover, the energy-absorbing properties of such materials tend to diminish with increasing temperatures, whereas the positive rebound properties diminish with decreasing temperatures. There remains a need, therefore, for an improved helmet construction that can reduce the risk and severity of concussions without the aforementioned disadvantages of current helmet designs.

SUMMARY

[0008] In one aspect, the invention features protective headgear comprising an outer layer having an internally facing surface, an inner layer having a surface that faces the outer layer, and a middle layer having a plurality of compressible members disposed in a fluid-containing interstitial region bounded by the inner and outer layers. Each compressible member is attached to the surface of the inner layer and to the internally facing surface of the outer layer. The protective headgear also has at least one passageway by which fluid can leave the middle layer when the protective headgear experiences an impact.

[0009] In another aspect, the invention features a method for making protective headgear comprising forming a multi-layered shell by forming a plurality of individually compressible members, providing an outer layer and an inner layer, and producing a composite structure with the individually compressible members being disposed in an interstitial region bounded by the outer and inner layers, each compressible member being attached to an internally facing surface of the outer layer and to a surface of the inner layer facing the outer layer.

BRIEF DESCRIPTION OF THE DRAWINGS

[0010] The above and further advantages of this invention may be better understood by referring to the following

description in conjunction with the accompanying drawings, in which like numerals indicate like structural elements and features in various figures. The drawings are not necessarily to scale, emphasis instead being placed upon illustrating the principles of the invention.

[0011] FIG. 1 is a side view of an embodiment of a helmet constructed in accordance with the present invention.

[0012] FIG. 2 is a cross-sectional view of the helmet of FIG. 1 showing an embodiment of a layered construction having a hard inner layer disposed between a compressible internal layer and a middle layer.

[0013] FIG. 3 is a side view of another embodiment of a helmet constructed in accordance with the present invention.

[0014] FIG. 4 is a cross-sectional view of another embodiment of a layered construction for protective headgear embodying the invention, the embodiment having a multilayer shell with a plurality of compressible members disposed between an outer surface and an inner surface.

[0015] FIG. 5 is a diagram illustrating an embodiment of a simplified manufacturing schematic for forming a multilayer shell for use, for example, in constructing protective headgear.

[0016] FIG. 6 is a diagram illustrating an embodiment of a simplified manufacturing schematic for adding an internal liner to the multilayer shell of FIG. 5.

[0017] FIG. 7A is a diagram illustrating the operation of protective headgear of the invention during a direct impact.

[0018] FIG. 7B is a diagram illustrating the operation of protective headgear of the invention during a tangential impact.

[0019] FIG. 8A is a diagram of an embodiment of a compressible member having a hollow chamber for holding a volume of fluid.

[0020] FIG. 8B is a diagram of a sequence illustrating simulated effects of a high-energy impact to the compressible member of FIG. 8A.

[0021] FIGS. 8C and 8D are diagrams illustrating the stretching and bending capabilities of the compressible member of FIG. 8A.

[0022] FIG. 8E is a diagram of the compressible member of FIG. 8A when compressed.

[0023] FIG. 9A is a diagram of another embodiment of a compressible member with a hollow chamber for holding a volume of fluid.

[0024] FIG. 9B is cross-sectional view of an embodiment of a shell having openings formed in the outer and inner layers thereof for the passage of fluid.

[0025] FIG. 10A is a cross-sectional view of an embodiment of a shell having an outer shell, an inner layer, and a plurality of compressible members disposed therebetween.

[0026] FIG. 10B is a diagram illustrating the shell of FIG. 10A on a wearer's head.

[0027] FIG. 10C is a diagram illustrating the operation of protective headgear of FIG. 10A during a direct impact.

[0028] FIG. 10D is a diagram illustrating the operation of protective headgear of FIG. 10A during a tangential impact.

[0029] FIG. 11A is a rear view of an embodiment of protective headgear employing compressible members of FIG. 9A.

[0030] FIG. 11B is a cross-sectional view of an embodiment of a shell having an outer shell, an inner layer, and a plurality of compressible members disposed therebetween.

DETAILED DESCRIPTION

[0031] The present invention relates to protective headgear designed to lessen the amount of force that reaches the brain of the wearer from an impact to the head. The headgear has a shell with a multilayer construction for cushioning the impact, thus slowing the change in velocity of the wearer's head, producing a corresponding decrease in the magnitude of acceleration or deceleration experienced by the wearer, and reducing the risk or severity of concussion. As described further below, the shell has an outer layer, an energy-absorbing layer, and an inner layer, with one or more of these layers being constructed of an energy-absorbing compressible material. In a preferred embodiment, this compressible material is a thermoplastic elastomer (TPE).

[0032] Various embodiments of the energy-absorbing layer of the shell function to provide an air cushion during an impact to the headgear. In a preferred embodiment, an impact causes air to be expelled from the energy-absorbing layer. Protective headgear of the invention can respond to an impact by moving in any one or combination of ways, including (1) globally compressing over a broad area of the shell, (2) locally compressing at the point of impact, (3) flexing by the outer layer of the shell, and (4) rotating by the outer layer and the energy-absorbing layer with respect to the inner layer.

[0033] The layered construction of the invention can be used to construct a variety of types of protective headgear including, but not limited to, safety helmets, motorcycle helmets, bicycle helmets, ski helmets, lacrosse helmets, hockey helmets, and football helmets, batting helmets for baseball and softball, headgear for rock and mountain climbers, and headgear for boxers. Other applications can include helmets used on construction sites, in defense and military applications, and for underground activities. Although the following description focuses primarily on protective headgear, it is to be understood that the layered construction of the invention applies to other types of equipment used for sports activities or for other applications, e.g., face masks, elbow pads, shoulder pads, and shin pads.

[0034] FIG. 1 shows a side view of an embodiment of a helmet 2 constructed in accordance with the invention. Here, the helmet 2 has an aerodynamic shape designed for use by bicyclists. This shape is merely exemplary; it is to be understood that the helmet shape can vary, depending upon the particular sporting event or activity for which the helmet is designed. Further, helmets of the invention can be constructed with various additional features, such as a cage for a hockey helmet, a face mask for a football helmet, a visor for a motorcycle helmet, retention straps, chin straps, and the like.

[0035] The helmet 2 has ventilation openings 6 near the top to permit air to flow for cooling the wearer's head. Here,

the ventilation openings 6 are teardrop shaped, each pointing toward the rear 10 of the helmet 2 to give a visual sensation of speed. For clarity sake, the various layers of the materials used in the construction of the helmet 2 appear in the openings 6 as a single layer 14. Ventilation openings can also be on the other side of the helmet 2 (not shown) if the helmet has a symmetric design. Such openings 6 are exemplary, and can have various other shapes or be omitted altogether, depending upon the type of helmet. Also, helmets constructed in accordance with the invention can have other types of openings, such as ear holes.

[0036] FIG. 2 shows a cross section of the helmet 2 along the line A-A' in FIG. 1. In the embodiment shown, the helmet 2 includes an outer shell layer 20, a compressible middle layer 24, a hard inner shell layer 28, and a compressible internal liner 32. The outer shell layer 20, middle layer 24, and inner shell layer 28 together provide an impact-absorbing shell 30 of the present invention. As used herein, a layer is compressible based on the relative ease with which that layer decreases in thickness in response to an applied force. In general, compressible layers are more apt to decrease in thickness in response to an applied force than hard layers. The compressible layers 24, 32 can compress discernibly in response to an applied force. In contrast, no readily discernible compression, as defined by a readily discernible decrease in thickness, occurs if a comparable force is applied directly to the inner shell layer 28, although that layer may temporarily deform by bending. Numerical hardness values, determined according to any one of a variety of hardness tests, such as a Shore (Durometer) Test, can be used to measure the relative hardness of each layer. In general, compressible layers measure softer than hard layers.

[0037] As described in detail below, each of the layers can be constructed of a lightweight material, thus contributing towards the construction of a lightweight helmet. Although not drawn to scale, FIG. 2 shows one example of the relative thicknesses of the various layers and coating. These relative thicknesses can also depart from those shown in FIG. 2 without departing from the principles of the invention. For example, a bike helmet could be made with a thick inner shell layer 28 (e.g., of expanded polystyrene) and with a middle layer 24 of TPE that is thinner than the inner shell layer 28. Also, additional layers can be disposed between the middle layer 24 and the inner shell layer 28, or between the internal liner 32 and the inner shell layer 28, without departing from the principles of the invention.

[0038] The outer shell layer 20 covers the middle layer 24 and serves various functions. For example, the outer shell layer 20 can provide durability by protecting the helmet 2 from punctures and scratches. Other functions include presenting a smooth surface for deflecting tangential impacts, waterproofing, and displaying cosmetic features such as coloring and identifying the product brand name. In a preferred embodiment, this outer shell layer 20 is made of a thermoplastic material.

[0039] Beneath the outer shell layer 20, the compressible middle layer 24 covers an outer surface of the inner shell layer 28. The middle layer 24 attaches to the inner shell layer 28. A primary function of the middle layer 24 is impact energy absorption. Preferably, the middle layer 24 is constructed of a thermoplastic elastomer material.

[0040] Thermoplastic elastomers or TPEs are polymer blends or compounds, which exhibit thermoplastic characteristics that enable shaping into a fabricated article when heated above their melting temperature, and which possess elastomeric properties when cooled to their designed temperature range. Accordingly, TPEs combine the beneficial properties of plastic and rubber, that is, TPEs are moldable and shapeable into a desired shape when heated and are compressible and stretchable when cooled. In contrast, neither thermoplastics nor conventional rubber alone exhibits this combination of properties. Further, introduction of a chemical foaming agent during processing can change certain TPEs into foam. This foaming serves to reduce the density and weight of the material, and to increase its compressibility. The resulting foam material remains a TPE.

[0041] To achieve satisfactory purposes, conventional rubbers must be chemically crosslinked, a process often referred to as vulcanization. This process is slow, irreversible, and results in the individual polymer chain being linked together by covalent bonds that remain effective at normal processing temperatures. As a result, vulcanized rubbers do not become fluid when heated to these normal processing temperatures (i.e., the rubber cannot be melted). When heated well above normal processing temperatures, vulcanized rubbers eventually decompose, resulting in the loss of substantially all useful properties. Thus, conventional vulcanized rubbers cannot be formed into useful objects by processes that involve the shaping of a molten material. Such processes include injection molding, blow molding and extrusion, and are extensively used to produce useful articles from thermoplastics.

[0042] Thermoplastics are generally not elastic when cooled and conventional rubbers are not moldable using manufacturing processes and equipment currently used for working with thermoplastics, such as injection molding and extrusion. These processes, however, are applicable for working with TPEs.

[0043] Most TPEs have a common feature: they are phase-separated systems. At least one phase is hard and solid at room temperature and another phase is elastomeric and fluid. Often the phases are chemically bonded by block or graft polymerization. In other cases, a fine dispersion of the phases is apparently sufficient. The hard phase gives the TPEs their strength. Without the hard phase, the elastomer phase would be free to flow under stress, and the polymers would be unusable. When the hard phase is melted, or dissolved in a solvent, flow can occur and therefore the TPE can be processed. On cooling, or upon evaporation of the solvent, the hard phase solidifies and the TPEs regain their strength. Thus, in one sense, the hard phase of a TPE behaves similarly to the chemical crosslinks in conventional vulcanized rubbers, and the process by which the hard phase does so is often called physical crosslinking. At the same time, the elastomer phase gives elasticity and flexibility to the TPE.

[0044] Examples of TPEs include block copolymers containing elastomeric blocks chemically linked to hard thermoplastic blocks, and blends of these block copolymers with other materials. Suitable hard thermoplastic blocks include polystyrene blocks, polyurethane blocks, and polyester blocks. Other examples of TPEs include blends of a hard thermoplastic with a vulcanized elastomer, in which the

vulcanized elastomer is present as a dispersion of small particles. These latter blends are known as thermoplastic vulcanizates or dynamic vulcanizates.

[0045] TPEs can also be manufactured with a variety of hardness values, e.g., a soft gel or a hard 90 Shore A or greater. One characteristic of the TPE material is its ability to return to its original shape after the force against the helmet **2** is removed (i.e., TPE material is said to have memory). Other characteristics of TPE include its resistance to tear, its receptiveness to coloring, and its rebound resilience elasticity. Rebound resilience elasticity is the ratio of regained energy in relation to the applied energy, and is expressed as a percentage ranging from 0% to 100%. A perfect energy absorber has a percentage of 0%; a perfectly elastic material has a percentage of 100%. In general, a material with low rebound resilience elasticity absorbs most of the applied energy from an impacting object and retransmits little or none of that energy. To illustrate, a steel ball that falls upon material with low rebound resilience elasticity experiences little or no bounce; the material absorbs the energy of the falling ball. In contrast, the ball bounces substantially if it falls upon material with high rebound resilience elasticity.

[0046] Preferred embodiments of the middle layer **24** are constructed of a TPE material with low rebound resilience elasticity (here, a low rebound resilience elasticity corresponds to a rebound percentage of approximately 50% or less, and preferably 25% or less). Examples of TPEs with low rebound resilience elasticity include Trefsin™, manufactured by Advanced Elastomer Systems of Akron, Ohio, and the product TP6DAA manufactured by Kraiburg TPE Corp of Duluth, Ga. An advantage of these TPEs is that their low rebound characteristic exists over a wide range of temperatures. Preferably, the TPE material of the middle layer **24** has a glass-transition temperature of less than -20 degrees Fahrenheit. The glass-transition temperature is the temperature below which the material loses its soft and rubbery qualities. A TPE material with an appropriate glass-transition temperature can be selected for the middle layer **24** depending on the particular application of the helmet **2** (e.g., a glass-transition temperature of 0 degrees Fahrenheit may be sufficient for baseball helmets, whereas a glass-transition temperature of -40 degrees Fahrenheit may be needed for football and hockey helmets).

[0047] TPEs can also be formed into a variety of structures. In one embodiment, the middle layer **24** is processed into individual members, such as cylindrical columns, or other shapes such as pyramids, spheres, or cubes, allowing for independent movement of each member structure, and for the free flow of air around the members during an impact. Preferably, the individual members each have an air-filled chamber, as described in more detail below. In another embodiment, the layer has a honeycomb structure (i.e., waffle-type). The interconnected hexagonal cells of a honeycombed structure provide impact absorption and a high strength-to-weight ratio, which permits construction of a lightweight helmet. The interconnected cells absorb and distribute the energy of an impact evenly throughout the structure. The honeycomb structure also reduces material costs because much of the material volume is made of open cells. This structure can be any one in which the material is formed into interconnected walls and open cells. The cells can have a shape other than hexagonal, for example, square,

rectangular, triangular, and circular, without departing from the principles of the invention.

[0048] The formation of the middle layer **24** on the inner shell layer **28** can be accomplished using an extrusion, blow molding, casting, or injection molding process. The compressible middle layer **24** and inner shell layer **28** can be manufactured separately and adhered together after production, or they may be manufactured as one component, with the two layers being adhered to each other during manufacturing. TPEs bond readily to various types of substrates, such as plastic, and, thus, TPEs and substrates are commonly manufactured together. With respect to solid and foam forms of TPE structures, the softness (or conversely, the hardness) of the middle layer **24** can also be determined over a range of durometers. Preferably, the hardness range for these forms is between 5 and 90 on the Shore A scale, inclusive. The thickness of the middle layer **24** can be varied without departing from the principles of the invention. In one embodiment, the middle layer **24** is approximately ¼ to one inch thick.

[0049] The inner shell layer **28** is constructed of a hardened material, such as a rigid thermoplastic, a thermoplastic alloy, expanded polystyrene, or a fiber-reinforced material such as fiberglass, TWINTEX®, KEVLAR®, or BP Curv™. The inner shell layer **28** operates to provide structure to the helmet **2**, penetration resistance, and impact energy distribution to the internal liner **32**. In one embodiment, the thickness of the inner shell layer **28** is ¼th of an inch. The thickness of the inner shell layer **28** can be varied without departing from the principles of the invention.

[0050] Providing another impact energy-absorbing layer, the internal liner **32** contacts the wearer's head. Other functions of the internal liner **32** may include sizing, resilience, airflow, and comfort. In general, the internal liner **32** is constructed of a thermoplastic elastomer, a foam material of, for example, approximately ½ to 1 inch thickness, or it may be constructed of expanded polystyrene. The compressible internal liner **32** is attached to an inner surface of the inner shell layer **28**. The method of attachment depends upon the type of materials used (of the inner shell layer **28** and of the internal liner **32**).

[0051] Embodiments of the internal liner **32** include one or more of the following, either alone or in combination: thermoplastic elastomer (TPE), expanded polystyrene, expanded polypropylene, vinyl nitrile, silicone gel, silicone foam, viscoelastic or memory foam, and polyurethane foam. The thickness and type of foam material can be varied without departing from the principles of the invention.

[0052] Important to the use of the helmet of the invention is for the helmet to fit properly and to remain in place during the impact. In an embodiment not shown, the helmet extends downwards from the regions near the ears and covers the angle of the wearer's jaw. This extension may be flexible, and when used in conjunction with a chinstrap, may be drawn in tightly to provide a snug fit around the jaw. FIG. 3 shows another embodiment of a helmet **2'** constructed in accordance with the invention. Here, the helmet **2'** is a football helmet (facemask and chinstrap not shown). This helmet **2'** illustrates a design that covers the ears and a portion of the wearer's jaw. The helmet **2'** has ventilation openings **6'** near the top and on the sides of the helmet **2'** and an ear hole **8**. Again, for clarity sake, the various layers of

materials used in the construction of the helmet 2' appear in each opening 6' as a single layer 14'.

[0053] FIG. 4 shows a cross-section of an embodiment of a layered shell 30' for use, for example, in the construction of protective headgear. The shell 30' has an outer layer 20', an inner layer 28', and a plurality of independent compressible members 50 disposed between the inner and outer layers 28', 20'. Each member 50 attaches to an internally facing surface of the outer layer 20' and to a surface of the inner layer 28' that faces the outer layer 20'. Members 50 are independent in that each individual member 50 can compress or shear independently of the other members 50. Here, members 50 have a resilient, compressible solid or foam construction.

[0054] Members 50 can range from approximately one-eighth inch to one inch in height and one-eighth inch to one-half inch in diameter, and need not be of uniform height or diameter. Although shown to have the shape of columns, the members 50 can have a variety of shapes, for example, pyramidal, cubic, rectangular, spherical, disc-shaped, and blob-shaped. Preferably, the members 50 are constructed of TPE material (e.g., solid form, foam), although other types of compressible materials can be used for producing the members 50, without departing from the principles of the invention, provided such materials can make the members sufficiently resilient to respond to various types of impact by leaning, stretching, shearing, and compressing.

[0055] In one embodiment, there is a spatial separation between each member 50. Referred to herein as an interstitial region 52, the spacing between the members 50 bounded between the inner and outer layers 28', 20' defines a volume of fluid. As used herein, this fluid is any substance that flows, such as gas and liquid. The distance between adjacent members 50 can be designed so that a desired proportion of the volume of the shell 30' (e.g., >50%) is comprised of fluid. In a preferred embodiment, the fluid within the interstitial region 52 is air. An air-containing interstitial region 52 provides for lightweight headgear.

[0056] In FIG. 4, the distance between the outer layer 20' and the inner layer 28' is exaggerated in order to reveal the members 50 of the middle layer 24'. (The middle layer 24' here comprises the members 50 and interstitial region 52). In general, the outer layer 20' and inner layer 28' approach and may touch each other so that any gap between the layers 20', 28' either is imperceptible or does not exist. Preferably, the outer and inner layers are not directly attached to each other at any point along the shell 30'. Not directly attaching the layers enables the outer layer to move during impact independently of the inner layer in a scalp-like fashion. At one or more points along the edge of the shell where the outer layer approaches the inner layer, an elastic adhesive or another intervening substance or material, can be applied in between the two layers in order to make the layers 20', 28' closely approximate other. This adhesive can be an elastomeric gel (similar to rubber cement) or an adhesive strip that attaches to each layer 20', 28'. Despite this adhesive attachment of the intervening material to each layer 20', 28', the outer layer can still move relative to the inner layer in scalp-like fashion. Gaps may be present in this adhesive at various locations along the edge of the shell to permit air to escape from the middle layer 24' during an impact to the shell or to enter the middle layer 24' when the impact is over, as described in more detail below.

[0057] FIG. 5 shows an embodiment of a simplified manufacturing schematic for producing the shell 30' for use in constructing protective headgear. In this example, the compressible members 50 are constructed of TPE material 54. In step 60, a TPE foam 58 is produced from the TPE material 54, as described above. At step 64, the TPE foam 58 is extruded into a desired structure 61, here, for example, columnar members. Initial construction of the compressible members may be in the form of a chain (i.e., a single continuous string of multiple members, analogous to coupling between cars of a train). Alternatively, the compressible members may be formed together as a larger unit, which has an appearance analogous to that of a rake when the TPE structure 61 is laid flat and which takes a hemispherical shape when laid onto the inner layer 28'. Other techniques for forming the members together can be practiced to produce the desired structure 61.

[0058] The TPE foam structure 61 is placed (step 68) between and attached to a first sheet 62 of material, to serve as the inner layer 28', and a second sheet 63 of material to serve as the outer layer 20'. The compressible members may be attached to the inner layer 28' one member 50 at a time, for example, by adhesive. Alternately, each member 50 can have a point, nozzle, stem, which can be inserted into an appropriately shaped opening in the inner layer 28' to hold that member in place. In one embodiment, the TPE foam structure 61 has a common chemical component as the sheets 62, 63 for the inner and outer layers, thus enabling chemical adhesion between the TPE foam structure and each layer during the manufacturing process. Thus, secondary adhesives are unnecessary, although not precluded from being used, to attach the TPE foam structure to these layers. The resulting sheet of composite structure 65 can then be cut (step 72) and formed (step 76) into the desired shape of the shell 30' (only a portion of the shell being shown).

[0059] Instead of cutting and shaping the inner, middle, and outer layers together, as described above, the manufacture and shaping of each of the three layers of the shell can occur independently, and then the independently formed layers can be adhered to one another. As another embodiment, the middle and inner layers can be shaped together and the outer layer independently; then, the outer layer can be adhered to the middle layer. This embodiment can lead to the modularization of the manufacture of helmets. For instance, the interior components of a helmet, i.e., the liner, inner layer, and middle layer, can have standardized construction (i.e., the same appearance irrespective of the type of sports helmet for which the interior components are to be used), with the outer sport-specific layer, which is adhered to the middle layer, or injection molded around the interior components, providing the customization of the helmet for a particular sport.

[0060] As shown in FIG. 6, a compressible (e.g., foam) internal liner 32' can then be added (step 80) to the multi-layer shell 30'. FIG. 6 shows a cross-section of a portion of the shell 30' and of the internal liner 32'. The internal liner 32' is attached (e.g., with an adhesive) to an internally facing surface of the inner layer 28'. The shape of the internal liner 32' conforms to the general shape of the shell 30' and to the shape of a wearer's head.

[0061] The shell 30' of the invention may reduce both linear acceleration and rotational acceleration experienced

by the head of the headgear wearer. Linear acceleration occurs when the center of gravity of the wearer's head becomes rapidly displaced in a linear direction, such as might occur when the headgear is struck from the side. Rotational acceleration, widely believed to be a primary cause of concussion, can occur when the head rotates rapidly around the center of gravity, such as might occur when the headgear is struck tangentially. Most impacts impart both types of accelerations.

[0062] FIG. 7A illustrates an exemplary simulated operation of the shell 30', with solid or foam members 50', undergoing a direct impact from an object 100. In this example, the shell 30' operates to reduce linear acceleration of the headgear wearer's head 104. When the object 100 strikes the outer layer 20', the members 50' directly beneath the outer layer 20' at the point of impact compress. The compression of the shell 30' also causes air to exit the middle layer 24' (arrow 108) through one or more openings at an edge of the shell 30' where the inner and outer layers 28', 20' approach each other. Air also moves through the interstitial region away from the point of impact (arrow 110). The combined effects of energy-absorption by the compressible members 50' and air cushioning by the release and movement of air operate to reduce the amount of energy that reaches the wearer's head 104. When the force of the impact subsides, the shape and resilience of the inner and outer layers 28', 20', operate to restore the shell 30' and the compressed members 50' to their original shape. When returning to the original shape, the shell 30' in effect inhales air through each opening at the edge.

[0063] FIG. 7B illustrates an exemplary simulated operation of the shell 30', with solid or foam members 50', undergoing a tangential impact from an object 100. In this example, the shell 30' operates to reduce rotational acceleration of the wearer's head 104. When struck by an object tangentially, the outer layer 20' shears with respect to the inner layer 28' in a direction of motion of the object, as illustrated by arrows 112. The smoothness of the outer layer 20' can operate to reduce friction with the object 100 and, correspondingly, to reduce the rotational force experienced by the shell 30'. Members 50' at the point of impact compress to some extent and shear with the outer layer 20'. As with the example of FIG. 7A, the compression causes air to exit the middle layer 24' and to move within the interstitial region. The combined effects of the shearing motion of the outer layer 20' and members 50', of the energy-absorbing compression of the middle layer 24', and of the release and movement of air operate to reduce the rotational force reaching the wearer's head 104. The shell 30' and members 50' return to their original shape after the force of the impact subsides.

[0064] FIG. 8A shows an embodiment of a compressible member 50' for use in constructing the middle layer 24' for the shell 30' in accordance with the invention. Embodiments of the invention can use this type of member 50' in conjunction with or instead of openings at the edge of the shell 30'. Making the member 50' of TPE material further operates to improve the energy-absorbing effect of the shell, although other types of compressible materials can be used for producing the member 50'. The member 50' has a top surface 120, a bottom surface 124, and a sidewall 128 that define a hollow internal chamber 132. The top surface 120 attaches to the outer layer 20' of the shell 74, and the bottom surface

124 attaches to the inner layer 28'. The bottom surface 124 has a small opening 136 formed therein. When the member 50' compresses in the general direction indicated by arrow 140, airflow 144, for example, exits the small opening 136.

[0065] The size of the opening 136 is designed to produce a rate-sensitive response to any impact causing compression of the member 50'. For instance, if the application of force upon the member 50' is gradual or of relatively low energy, the opening 136 permits sufficient air to pass through so that the member 50' compresses gradually and presents little resistance against the force. For example, an individual may be able to compress the shell of the protective headgear manually with a moderate touch of a hand or finger, because the energy-absorbing middle layer and, in some embodiments, the outer and inner layers are made of compressible materials. Because the application of the force is gradual, the wearer's head is not likely to accelerate significantly and thus is less likely to experience concussion. In addition, the wearer may feel the air being expelled from the members 50' onto his or her head, as described further below.

[0066] If, as illustrated by FIG. 8B, the application of force upon the member 50' occurs instantaneously or is of relatively high energy, the energy of impact is converted to heat, and laminar or turbulent air flows within the chamber 132. The size of the opening 136, which is small relative to the volume of air moved by the force, restricts the emission of the turbulent or laminar air from the chamber 132 and thus causes resistance within the chamber 132. Eventually the resistance is overcome and air flows out, but during this process, the impact energy is thus converted to heat. This conversion of impact energy to heat occurs in some proportion to the amount of energy delivered, also termed a rate-sensitive or a non-linear response, and reduces the energy delivered to the head. An advantage of this structure is that when the member 50' compresses and empties the entire volume of air, a length of TPE material remains, which further absorbs energy. This helps prevent "bottoming out", i.e., fully compressing so that the cushioning effect of the member 50' is lost and the impinging force transfers directly to the wearer's head. In addition to providing this rate-sensitive response, the member 50' can also stretch and bend during tangential impact similarly to the members 50' described above, as illustrated by FIG. 8C and FIG. 8D.

[0067] FIG. 8E shows the embodiment of the compressible member 50' after becoming compressed. Because of its resilient nature, the tendency of the member 50' is to return to its uncompressed shape. The inner and outer layers 28', 20' to which the member 50' is attached also contribute to the restoration of the member 50' to its uncompressed shape. The tendencies of the inner and outer layers 28', 20' to return to their pre-impact shape, because of their semi-rigidness and resiliency, operate to pull the member 50' back to its uncompressed shape. Accordingly, after the force is removed from the shell 30', the member 50' expands in the direction indicated by arrow 150, consequently drawing air in through the opening 136 as indicated by arrows 144'. FIG. 8F illustrates a simulated sequence of expansion of a rate-sensitive compressible member 50', as the force is removed.

[0068] FIG. 9A shows a cross-section of another embodiment of a rate-sensitive compressible member 50' that is generally rectangular in shape (i.e., a strip). The member 50''

has a top surface 160, a bottom surface 164, sidewalls 168-1, 168-2 (generally, 168), and a hollow internal chamber 172. The top surface 160 attaches to the internally facing surface of the outer layer 20' of the shell 30", and the bottom surface 164 attaches to a surface of the inner layer 28'. Each sidewall 168 has a respective small opening 176-1, 176-2 (generally, 176) formed therein. (Practice of the invention can be achieved with only one of the sidewalls 168 having an opening). When the member 50" compresses generally in the direction indicated by arrow 180, airflows 184 exit the small openings 176 and pass through the interstitial region of the shell. This embodiment illustrates that a variety of shapes, for example, disc-shaped, cylindrical, and pyramidal, can be used to implement rate-sensitive compressible members of the invention, capable of converting impact energy to heat of turbulent or of laminar airflow.

[0069] FIG. 9B shows a cross-section of a shell 30" having a plurality of rate-sensitive compressible members 50" disposed between the outer layer 20' and inner layer 28'. Each compressible member 50" has a plurality of openings 176 for the passage of fluid (i.e., air). The inner layer can have an openings 200 formed therein, to permit the passage of fluid. Fluid escaping the rate-sensitive compressible members 50" during impact, or returning to the compressible members 50" after impact, thus have avenues for leaving and entering the shell 30". Embodiments of the invention can have one or more of such openings 200 in addition to or instead of openings at the edge of the shell. Further, other embodiments can use such openings 200 with other types of compressible members (e.g., those described in FIG. 4).

[0070] FIG. 10A shows a cross-section of an embodiment of a shell 230 having an outer layer 220, an inner layer 228, and a plurality of the rate-sensitive compressible members 50' (FIG. 8A) disposed therebetween. The opening 136 of each rate-sensitive compressible member 50' aligns with an opening (not shown) in the surface of the inner layer 228 and through any liner 232 so that expelled or inhaled air (arrows 210) can pass into the interior of the protective headgear. Similarly, such openings 136 can be on the sides of the compressible member 50', allowing the release and return of air through the interstitial region of the shell 230. FIG. 10B shows the shell 230, with rate-sensitive compressible members 50' and an internal liner 232, on the head 234 of a user.

[0071] FIG. 10C illustrates an exemplary simulated operation of the shell 230, with rate-sensitive members 50', undergoing a direct impact from an object 236. In this example, the shell 230 operates to reduce linear acceleration of the headgear wearer's head 234. When the object 236 strikes the outer layer, the members 50' directly beneath the outer layer at the point of impact compress. The compression of the shell 230 also causes air to exit the members 50' (arrows 238) and enter the interior of the headgear through the openings in the members 50' and in the inner layer.

[0072] FIG. 10D illustrates an exemplary simulated operation of the shell 230, with rate-sensitive compressible members 50', undergoing a tangential impact from an object 236. In this example, the shell 230 operates to reduce rotational acceleration of the wearer's head 234. When struck by an object tangentially, the outer layer shears with respect to the inner layer in a direction of motion of the object, as illustrated by arrows 240. Members 50' at the point

of impact compress to some extent and shear with the outer layer. As with the example of FIG. 10C, the compression causes air to exit the members 50' and to enter the interior of the headgear. The combined effects of the shearing motion of the outer layer and members 50', of the rate-sensitive and energy-absorbing compression of the members 50', and of the release of air into the interior of the headgear operate to reduce the rotational force reaching the wearer's head 104.

[0073] As an illustration of an exemplary use of the invention, FIG. 11A shows a rear view of an embodiment of protective headgear 250 embodying the invention. The headgear 250 includes a pattern 254 of strip-shaped members 50" (FIG. 9A) disposed between outer and inner layers of the shell. FIG. 11B shows a side view of the headgear 250 with another pattern 258 of strip-shaped members 50". A variety of other patterns is possible without departing from the principles of the invention.

[0074] While the invention has been shown and described with reference to specific preferred embodiments, it should be understood by those skilled in the art that various changes in form and detail may be made therein without departing from the spirit and scope of the invention as defined by the following claims. For example, more than one type of compressible member can be combined to construct a shell for a protective headgear.

What is claimed is:

1. Protective headgear, comprising:

an outer layer having an internally surface;

an inner layer having a surface that faces the outer layer;

a middle layer having a plurality of compressible members disposed in a fluid-containing interstitial region formed by the inner and outer layers; and

at least one passageway by which fluid can leave the middle layer as the outer layer deforms in response to an impact on the outer layer.

2. The protective headgear of claim 1, wherein the at least one passageway includes a gap between a peripheral edge of the outer layer and a peripheral edge of the inner layer to permit fluid to exit the interstitial region in response to an impact.

3. The protective headgear of claim 1, wherein the at least one passageway includes an opening in the inner layer.

4. The protective headgear of claim 3, wherein fluid that passes through the opening in the inner layer is felt by a wearer of the protective headgear.

5. The protective headgear of claim 1, wherein at least one of the compressible members is made of thermoplastic elastomer (TPE) material.

6. The protective headgear of claim 5, wherein the TPE material is a TPE foam.

7. The protective headgear of claim 1, wherein at least one of the compressible members is a columnar in shape.

8. The protective headgear of claim 1, wherein at least one of the compressible members includes a chamber for holding a volume of fluid, and the chamber includes a chamber surface having a chamber opening for the passage of fluid into and out of the chamber.

9. The protective headgear of claim 8, wherein the chamber opening is adapted to produce a rate-sensitive response to the force of the impact exerted on the outer layer.

10. The protective headgear of claim 8, wherein at least one compressible member expels fluid from the chamber through the chamber opening when the compressible member is compressed by the force of the impact and expands to draw fluid back into the chamber as the compressive force exerted on the outer layer is mitigated.

11. The protective headgear of claim 8, wherein the chamber is aligned with an opening in the inner layer to enable the passage of fluid through the inner layer.

12. The protective headgear of claim 1, wherein the inner layer includes an internal surface, and the headgear further comprising a compressible internal liner disposed inwardly of the internal surface of the inner layer.

13. The protective headgear of claim 1, wherein at least one compressible member includes a chamber for holding a volume of fluid, and the chamber includes a chamber surface having at least one chamber opening for passing fluid into and from the interstitial region formed by the outer and inner layers.

14. The protective headgear of claim 1, further comprising a resilient attachment for resiliently attaching and maintaining the orientation of the outer layer with respect to the inner layer.

15. The protective headgear of claim 1, wherein the outer layer shears rotationally with respect to the inner layer as the outer layer deforms in response to the impact.

16. A method for making protective headgear, the method comprising the steps of:

forming a multilayered shell by:

forming a plurality of individually compressible members;

providing an outer layer and an inner layer; and

producing a composite structure wherein the compressible members are disposed in a fluid-containing interstitial region formed by the outer and inner layers, such that the outer layer deforms and the compressible members correspondingly compress in response to an impact to the outer layer.

17. The method of claim 16, wherein at least one compressible member is formed of thermoplastic elastomer material.

18. The method of claim 17, further comprising the step of:

introducing a chemical foaming agent into the thermoplastic elastomer material to produce compressible members made of thermoplastic elastomer foam.

19. The method of claim 16, further comprising the step of:

forming at least one of the compressible members to include a chamber for holding a volume of fluid, the chamber defining a chamber surface having at least one chamber opening for the passage of fluid into and out of the chamber.

20. The method of claim 19, further comprising the step of:

releasing fluid through the at least one chamber opening into the interstitial region formed by the inner and outer layers as the outer layer deforms in response to the impact to the outer layer.

21. The method of claim 19, further comprising the step of:

aligning the at least one chamber opening with an opening of the inner layer; and

releasing fluid through the at least one chamber opening toward the head of a wearer as the outer layer deforms in response to an impact to the outer layer.

22. The method of claim 16, wherein the producing step is such that the outer layer shears rotationally with respect to the inner layer in response to the impact.

23. The protective headgear of claim 1, wherein the outer layer includes an internal surface, the inner layer includes a surface that faces the outer layer and at least one of the plurality of compressible members is attached to at least one of the internal surface of the outer layer and the surface of the inner layer that faces the outer surface.

24. The method of claim 16, wherein the outer layer includes an internal surface, the inner layer includes a surface that faces the outer layer and the method further comprises the step of:

attaching at least one of the plurality of compressible members to at least one of the internal surface of the outer layer and the surface of the inner layer that faces the outer layer.

25. Protective headgear, comprising:

a relatively thin outer layer having an outwardly facing surface;

a relatively thin inner layer having an area which is spaced apart from the outer layer; and

a middle layer disposed in an area formed by the outer layer and the inner layer, the middle layer comprising a plurality of compressible members;

the middle layer being adapted to resiliently compress in response to a bending deformation of the outer layer to absorb energy of an impact; and

the outer layer being adapted to shear with respect to the inner layer in response to a tangential component of the impact to the outer layer.

26. The protective headgear of claim 25, wherein the outwardly facing surface of the outer layer is relatively smooth to reduce the tangential component of the impact.

27. The protective headgear of claim 25, further comprising a relatively compressible inner liner disposed inwardly of the inner layer.

28. The protective headgear of claim 25, wherein the middle layer has a rebound resilience elasticity of about fifty percent (50%) or less.

29. The protective headgear of claim 28, wherein the middle layer has a rebound resilience elasticity of about twenty-five percent (25%) or less.

30. The protective headgear of claim 25, wherein the plurality of compressible members are disposed in a fluid-containing interstitial region bounded by the outer layer and the inner layer.

31. The protective headgear of claim 25, wherein the outer layer includes an internally facing surface and at least one of the compressible members of the middle layer is attached to at least one of a surface of the inner layer that faces the outer layer and the internally facing surface of the outer layer.

32. The protective headgear of claim 25, further comprising at least one passageway for passing fluid from the middle layer in response to the impact.

33. The protective headgear of claim 32, wherein the at least one passageway includes a gap between the outer layer and the inner layer.

34. The protective headgear of claim 32, wherein the at least one passageway includes at least one opening in the inner layer.

35. The protective headgear of claim 25, wherein at least one of the compressible members includes walls which define a fluid-containing internal chamber and the walls include at least one opening to permit fluid to exit the internal chamber in response to the impact.

36. The protective headgear of claim 25, wherein at least one of the compressible members has a bellows-like sidewall construction.

37. The protective headgear of claim 35, wherein the walls of the compressible member have a bellows-like sidewall construction to facilitate compression of the compressible member in response to the impact.

38. The protective headgear of claim 35, wherein the at least one opening in the walls of the compressible member is adapted to produce a rate-sensitive response to the force of the impact exerted on the outer layer such that the compressible member compresses with relatively little resistance when the impact is of relatively low energy and such that the compressible member compresses with relatively high resistance when the impact force is of relatively high energy.

39. The protective headgear of claim 38, wherein the at least one opening in the walls of the compressible member is adapted such that, when the impact is of relatively high energy, the compressible member compresses with sufficiently high resistance to convert energy of the impact to heat in the compressible member.

40. The protective headgear of claim 25, wherein at least one of the compressible members of the middle layer compresses in response to the bending deformation of the outer layer and resiliently shears with respect to the inner layer in response to the tangential impact component.

41. The protective headgear of claim 25, wherein the compressible members of the middle layer have a honeycomb structure of interconnected cells.

42. The protective headgear of claim 25, wherein the compressible members of the middle layer are arranged in a pre-determined pattern between the outer layer and the inner layer.

43. The protective headgear of claim 41, wherein the interconnected cells of the honeycomb-structured middle layer are arranged in a pre-determined pattern between the outer layer and the inner layer.

44. The protective headgear of claim 25, wherein the compressible members are made of thermoplastic elastomer (TPE) material.

45. The protective headgear of claim 44, wherein the TPE material is a TPE foam.

46. The protective headgear of claim 44, wherein the TPE material has a glass-transition temperature less than about minus twenty degrees (-20°) Fahrenheit.

47. The protective headgear of claim 41, wherein the honeycomb-structured middle layer is made of a thermoplastic elastomer (TPE) material.

48. The protective headgear of claim 47, wherein the TPE material is a TPE foam.

49. The protective headgear of claim 47, wherein the TPE material has a glass-transition temperature less than about minus twenty degrees (-20°) Fahrenheit.

50. The protective headgear of claim 35, wherein the at least one opening in the at least one compressible member permits fluid to enter the internal chambers thereof as the compressible member resiliently expands as the force of the impact is mitigated.

51. The protective headgear of claim 35, wherein the inner layer includes at least one opening in communication with the least one opening in the at least one compressible member to permit fluid exiting from the at least one compressible member when compressed to pass through the inner layer.

52. The protective headgear of claim 35, further comprising a relatively compressible inner liner layer disposed inwardly of the inner layer and wherein the inner layer and the inner liner layer include at least one opening in communication with the least one opening in the at least one compressible member to permit fluid exiting from the compressible member when compressed to pass through the inner layer and the inner liner layer.

53. The protective headgear of claim 25, wherein the compressible members are independent of one another.

54. The protective headgear of claim 25, wherein the compressible members are interconnected.

55. The protective headgear of claim 25, wherein the inner layer is of a relatively rigid thermoplastic material.

56. The protective headgear of claim 25, wherein the outer layer is of a thermoplastic material.

57. The protective headgear of claim 56, wherein the thickness of the thermoplastic material of the outer layer is such that the outer layer resiliently deforms by bending inwardly in response to the impact.

58. The protective headgear of claim 25, wherein the bending deformation of the outer layer and the compression of compressible members of the middle layer in response to the impact combine to reduce linear changes of velocity of a wearer's head due to the impact.

59. The protective headgear of claim 25, wherein the shearing of the outer layer with respect to the inner layer and of the compressible members of the middle layer in response to the impact combine to reduce rotational changes of velocity of the wearer's head due to the impact.

60. The protective headgear of claim 25, wherein the outer layer includes a plurality of ventilation openings.

61. Impact absorbing protective headgear, comprising

an inner layer;

an outer layer, the inner and outer layers having opposed surfaces; and

a middle layer comprising a plurality of compressible members, the middle layer extending between the inner and outer layers the inner and outer layers being at least partially coextensive so that when the outer layer is impacted, the outer layer deflects locally in response to the impact, thereby absorbing at least some of the energy created by the impact, and at least one of the compressible members of the middle layer compresses and shears relative to the inner layer to absorb impact energy not absorbed by the outer layer.

62. The protective headgear of claim 61, wherein the middle layer is anchored in at least one location to the

opposed surfaces of the inner layer and the outer layer, the inner and outer layers being at least partially coextensive.

63. The protective headgear of claim 61, wherein the outer layer comprises an outwardly facing surface and the outwardly facing surface of the outer layer is relatively smooth to reduce the tangential component of the impact.

64. The protective headgear of claim 61, further comprising a relatively compressible inner liner layer disposed inwardly of the inner layer.

65. The protective headgear of claim 61, wherein the middle layer has a rebound resilience elasticity of about fifty percent (50%) or less.

66. The protective headgear of claim 65, wherein the middle layer has a rebound resilience elasticity of about twenty-five percent (25%) or less.

67. The protective headgear of claim 61, wherein the plurality of compressible members are disposed in a fluid-containing interstitial region bounded by the outer layer and the inner layer.

68. The protective headgear of claim 61, wherein at least one of the compressible members of the middle layer is attached to a surface of the inner layer that faces the outer layer and to an internally facing surface of the outer layer.

69. The protective headgear of claim 61, further comprising at least one passageway by which fluid can leave the middle layer in response to the impact.

70. The protective headgear of claim 69, wherein the at least one passageway includes a gap between the outer layer and the inner layer.

71. The protective headgear of claim 69, wherein the at least one passageway includes at least one opening in the inner layer.

72. The protective headgear of claim 61, wherein at least one of the compressible member includes walls which define a fluid-containing internal chamber and the walls include at least one opening to permit fluid to exit the internal chamber in response to the impact.

73. The protective headgear of claim 61, wherein at least one of the compressible members has a bellows-like sidewall construction.

74. The protective headgear of claim 72, wherein the walls of the at least one compressible member has a bellows-like sidewall construction which facilitates compression of the compressible member in response to the impact.

75. The protective headgear of claim 72, wherein the at least one opening in the walls of the compressible member is adapted to produce a rate-sensitive response to the force of the impact exerted on the outer layer such that the compressible member compresses with relatively little resistance when the impact is of relatively low energy and such that the compressible member compresses with relatively high resistance when the impact force is of relatively high energy.

76. The protective headgear of claim 75, wherein the at least one opening in the walls of the compressible member is adapted such that, when the impact is of relatively high energy, the compressible member compresses with sufficiently high resistance to convert energy of the impact to heat in the compressible member.

77. The protective headgear of claim 61, wherein the middle layer has a honeycomb structure of interconnected cells.

78. The protective headgear of claim 61, wherein the compressible members of the middle layer are arranged in a pre-determined pattern between the outer layer and the inner layer.

79. The protective headgear of claim 77, wherein the interconnected cells of the honeycomb-structured middle layer are arranged in a pre-determined pattern between the outer layer and the inner layer.

80. The protective headgear of claim 61, wherein the compressible members are made of thermoplastic elastomer (TPE) material.

81. The protective headgear of claim 80, wherein the TPE material is a TPE foam.

82. The protective headgear of claim 80, wherein the TPE material has a glass-transition temperature less than about minus twenty degrees (-20°) Fahrenheit.

83. The protective headgear of claim 77, wherein the honeycomb-structured middle layer is made of a thermoplastic elastomer (TPE) material.

84. The protective headgear of claim 83, wherein the TPE material is a TPE foam.

85. The protective headgear of claim 83, wherein the TPE material has a glass-transition temperature less than about minus twenty degrees (-20°) Fahrenheit.

86. The protective headgear of claim 72, wherein the at least one opening in the compressible member permits fluid to be drawn into the internal chamber thereof as the compressible member resiliently expands in response to mitigation of the force of the impact.

87. The protective headgear of claim 72, wherein the inner layer includes at least one opening in communication with the at least one opening in the compressible member to permit fluid exiting from the compressible member when compressed to pass through the inner layer.

88. The protective headgear of claim 72, wherein the outer layer includes at least one opening in communication with the at least one opening in the compressible member to permit fluid exiting from the compressible member when compressed to pass through the outer layer.

89. The protective headgear of claim 72, further comprising a relatively compressible inner liner layer disposed inwardly of the inner layer and wherein the inner layer and the inner liner layer include at least one opening in communication with the at least one opening in the compressible member to permit fluid exiting from the compressible member when compressed to pass through the inner layer and the inner liner layer.

90. The protective headgear of claim 61, wherein the compressible members are independent of one another.

91. The protective headgear of claim 61, wherein the compressible members are interconnected.

92. The protective headgear of claim 91, wherein a first end of at least one of the compressible members is attached to the outer layer and a second end of the at least one compressible members is attached to the inner layer.

93. The protective headgear of claim 61, wherein the inner layer is of a relatively rigid thermoplastic material.

94. The protective headgear of claim 61, wherein the outer layer is of a thermoplastic material.

95. The protective headgear of claim 94, wherein the thickness of the thermoplastic material of the outer layer is such that the outer layer resiliently deforms by bending inwardly in response to the impact.

96. The protective headgear of claim 61, wherein the bending deformation of the outer layer and the compression

of the middle layer in response to the impact combine to reduce linear changes of velocity of a wearer's head due to the impact.

97. The protective headgear of claim 61, wherein the shearing of the outer layer with respect to the inner layer and

the compression of the middle layer in response to the impact combine to reduce rotational changes of velocity of the wearer's head due to the impact.

* * * * *