

UNITED STATES PATENT AND TRADEMARK OFFICE

BEFORE THE PATENT TRIAL AND APPEAL BOARD

GEOTAB INC. AND GEOTAB USA, INC.,
Petitioners,

v.

FRACTUS, S.A.
Patent Owner.

Case No. IPR2025-01027
Patent No. 11,349,200

**DECLARATION OF DANIEL VAN DER WEIDE, Ph.D.
IN SUPPORT OF PETITION FOR
INTER PARTES REVIEW OF U.S. PATENT NO. 11,349,200**

TABLE OF CONTENTS

I.	PERSONAL AND PROFESSIONAL BACKGROUND	1
II.	MATERIALS REVIEWED AND CONSIDERED	5
III.	MY UNDERSTANDING OF PATENT LAW	8
	A. Anticipation	10
	B. Obviousness.....	10
	C. Claim Interpretation.....	13
IV.	DESCRIPTION OF THE RELEVANT FIELD AND THE RELEVANT TIMEFRAME.....	15
V.	UNPATENTABILITY GROUND	16
VI.	PERSON OF ORDINARY SKILL IN THE ART (“POSA”).....	17
VII.	’200 PATENT	22
	A. Challenged Claims.....	27
VIII.	CLAIM INTERPRETATION	28
	A. “ <i>perimeter</i> ” (all claims).....	28
	B. “ <i>antenna box</i> ” (claims 2, 6-20)	29
	C. “ <i>antenna rectangle</i> ” (claims 2-3, 6-20).....	29
	D. “ <i>antenna contour</i> ” (all claims)	30
	E. “ <i>complexity factor</i> ,” “ F_{21} ,” “ F_{32} ” (all claims)	32
	1. Grids	33
	a. Second Grid G_2	33
	b. First Grid G_1	34
	c. Third Grid G_3	37
	2. Calculation.....	38
	a. “ F_{21} ”	38
	b. “ F_{32} ”	41
	3. Fractus’s ADT Litigation argument	43
	F. “ <i>wireless device</i> ” (all claims).....	43
	G. “ <i>4G communication standard</i> ” (all claims).....	43

1. Intrinsic evidence	45
2. Fractus’s Litigation Arguments.....	46
IX. GROUND 1: DOU+JING RENDERS OBVIOUS CLAIMS 1-15, 17, AND 19-20	48
A. Dou (EX1013)	48
B. Jing (EX1011).....	49
C. Dou+Jing	52
D. Claim 1	59
1. Preamble [1.PRE].....	59
2. Limitation [1.a].....	59
3. Limitation [1.b]	60
4. Limitation [1.c].....	63
a. UMTS background.....	66
b. LTE background	67
5. Limitation [1.d]	69
6. Limitation [1.e].....	72
7. Limitation [1.f].....	75
a. Calculating F_{21}	75
i. Grid G_2	75
ii. $N_2 = 27$	76
iii. Grid G_1	78
iv. $N_1 = 10$	79
v. Calculation $F_{21} = 1.43$	79
b. Calculating F_{32}	79
i. Grid G_3	79
ii. $N_3 = 88$	80
iii. Calculation $F_{32} = 1.70$	82
8. Limitation [1.g]	82
9. Limitation [1.h]	83

E. Claim 2	84
F. Claim 3	86
G. Claims 4, 5	90
H. Claim 6	90
1. Preamble [6.PRE]-[6.a], [6.d]-[6.e], [6.g].....	90
2. Limitation [6.b]	91
3. Limitation [6.c].....	91
4. Limitation [6.f]	92
5. Limitation [6.h]	92
I. Claim 7	93
J. Claim 8	93
K. Claim 9	94
L. Claim 10	94
M. Claim 11	94
1. Limitations [11.PRE]-[11.f], and [11.h].....	94
2. Limitation [11.g]	95
N. Claim 12	96
O. Claim 13	96
P. Claim 14	96
Q. Claim 15, 17	97
R. Claims 19, 20.....	98
X. GROUND 2: BALIARDA-543 ANTICIPATES AND/OR RENDERS OBVIOUS CLAIMS 1-20	98
A. Claims 1-20 Are Not Entitled To Priority Before April 7, 2014.	98
B. Analysis	110
XI. CONCLUSION.....	114
APPENDIX A: MATERIALS CONSIDERED	115
APPENDIX B: U.S. PATENT NO. 11,349,200 CLAIM LIST	121

ABBREVIATIONS

Abbreviation	Description
3GPP	3rd Generation Partnership Project
DCS	Digital Communication Service
DL	downlink
ETSI	European Telecommunication Standards Institute
E-UTRAN	Evolved Universal Terrestrial Radio Access Network
FDD	frequency division duplexing
GPS	Global Positioning System
GSM	Global System for Mobile Communications
HSDPA	High Speed Downlink Packet Access
HSPA	High Speed Packet Access
HSUPA	High Speed Uplink Packet Access
ISM	Industrial, Scientific, and Medical
LTE	Long Term Evolution
NAMPS	Narrowband Advanced Mobile Phone Service
PCB	printed circuit board
PCS	Personal Communication Service
PDA	personal digital assistant
PIFA	planar inverted-F antenna
TDD	time division duplexing
UL	uplink

Abbreviation	Description
UMTS	Universal Mobile Telecommunications System
UTRAN	UMTS Terrestrial Radio Access Network
UWB	ultra-wideband
VSWR	voltage standing wave ratio
WCDMA	Wideband Code Division Multiple Access
WiBro	Wireless Broadband
WiMax	Worldwide Interoperability for Microwave Access
WLAN	wideband local area network

I, Daniel van der Weide, Ph.D., declare:

1. I have been retained by Wolf, Greenfield & Sacks, P.C., counsel for Geotab Inc. and Geotab USA, Inc. (“Petitioners” or “Geotab”), to assess claims 1-20 (the “Challenged Claims”) of U.S. Patent No. 11,349,200 (“the ’200 patent”) (EX1003). I am being compensated for my time at my standard rate, plus actual expenses. My compensation is not dependent in any way upon the outcome of the *inter partes* review of the ’200 patent.

I. PERSONAL AND PROFESSIONAL BACKGROUND

2. My qualifications for forming the opinions set forth in this declaration are summarized below and explained in more detail in my current curriculum vitae, provided as EX1008. EX1008 also includes a list of my publications.

3. I am currently Grainger Institute for Engineering Professor of Electrical and Computer Engineering at the University of Wisconsin-Madison. I received my Bachelor of Science Degree in Electrical Engineering from the University of Iowa in 1987; my Master of Science Degree in Electrical Engineering from Stanford University in 1990; and my Ph.D. degree in Electrical Engineering from Stanford in 1993. I teach several courses in my area of expertise, which includes high-frequency electrical measurement and communications systems and advanced high-frequency circuit design and measurement.

4. I teach courses such as ECE 447 Applied Communications Systems, which focuses on the hardware aspects of wireless communications systems and uses the text “Microwave Transistor Amplifiers: Analysis and Design,” 2nd Ed., Guillermo Gonzalez, Upper Saddle River NJ: Prentice-Hall (1997); ECE 420 Electromagnetic Wave Transmission, which focuses on electromagnetic theory applied to waveguides, transmission lines and antennas and uses the text “Engineering Electromagnetics and Waves” (custom text containing chapters from both Engineering Electromagnetics and Electromagnetic Waves) by U. S. Inan and A. S. Inan (Pearson Custom); ECE 547 Advanced Communications Circuit Design, which focuses on wireless communication systems circuits, antennas and protocols, and uses the text “Microwave and RF Design of Wireless Systems,” David Pozar (Wiley, 2001).

5. I perform research on digital radio and communications systems ranging from RFID tags to lightwave transceivers, with emphasis on wireless circuits, antennas, and microwave communications. Some of my work on antennas (e.g. for medical imaging and RFID) has been supported by the National Science Foundation and commercialized. Furthermore, as a consultant, I have performed research on antennas for clients such as JDS-Uniphase (evaluating flexible substrates and metal deposition techniques for suitability as printed RFID antennas), Berntsen (designing and developing antennas for geolocation and buried

asset marking) and Terso (designing and developing RFID antennas for low-temperature reagent and medical sample storage.) I have also sold ultrabroadband antennas to medical imaging researchers through my startup, Tera-X, LLC.

6. I have published results of my work in several peer-reviewed journals and presented my findings at recognized conferences. Some representative publications related to performance of planar antennas and means of fabrication in the timeframe relevant to the '200 patent include: M. Martinez and D.W. van der Weide, "Compact single-layer depolarizing chipless RFID tag," *Microw. Opt. Technol. Lett.*, 58, 1897–1900 (2016); H. Y. Chen, A. S. Bhadkamkar, T. H. Chou, and D.W. van der Weide, "Vector backscattered signals improve piggyback modulation for sensing with passive UHF RFID tags," *IEEE Transactions on Microwave Theory and Techniques*, vol. 59, pp. 3538-3545 (2011); Chih-Chuan Yen, A.E. Gutierrez, D. Veeramani, and D.W. van der Weide (2007). Radar cross-section analysis of backscattering RFID tags. *IEEE Antennas and Wireless Propagation Letters*, 6(1), 279-81 (2007); H. Y. Chen, Y. W. Mak, S. Bae, A. Bhadkamkar, and D.W. van der Weide, "Wireless impedance measurement of UHF RFID tag chips," in *IEEE MTT-S International Microwave Symposium Digest (MTT)*, 2012, pp. 1-3; H. Y. Chen, S. Bae, A. Bhadkamkar, Y. W. Mak, and D.W. van der Weide, "Coupling passive sensors to UHF RFID tags," in *IEEE Radio and Wireless Symposium (RWS)*, 2012, pp. 255-258; Chih-Chuan Yen,

Dharmaraj Veeramani, Alfonso E. Gutierrez, and D.W. van der Weide, "RFID Tag Reading Effects of Cylindrical Conductive Packages," Proceedings of the 36th European Microwave Conference, pp. 733-736, Sept. 2006.

7. I am an expert in the field of antenna design and analysis with over two decades of experience spanning both academic research and industrial applications. My work has encompassed a wide range of antenna technologies, including planar, conformal, broadband, phased array, and near-field measurement systems. I have designed and optimized antennas for use in wireless communications, radar, medical devices, and sensing systems, often operating across challenging frequency regimes including UHF, microwave, and millimeter-wave bands. My academic contributions include numerous peer-reviewed publications on antenna characterization, impedance matching, radiation pattern synthesis, and electromagnetic simulation techniques.

8. Throughout my career, I have applied experimental, theoretical and computational methods to solve design antenna problems. This includes the use of full-wave electromagnetic solvers, analytical modeling, and inverse design approaches for optimizing radiation performance under real-world constraints. I have also developed and implemented measurement systems for validating antenna performance in both near-field and far-field configurations. In particular, I have led efforts to enhance near-field scanning and NF-to-FF transformations, which are

essential for characterizing large or high-frequency antennas in compact environments. These efforts have resulted in measurable improvements in characterization accuracy and throughput.

9. In addition to my technical work, I have served as a consultant and expert in matters involving antenna system performance, electromagnetic interference, and regulatory compliance. I have evaluated antenna-related claims in the context of intellectual property, product validation, and system interoperability. My combination of hands-on design experience, rigorous analysis capabilities, and familiarity with industry standards enables me to provide technically sound, legally defensible opinions on antenna-related technologies. I am a co-founder of ANTENNEX, B.V. (Eindhoven, Netherlands), which develops new characterization technologies for (especially) integrated antennas used in wireless devices, such as those in the patent.

II. MATERIALS REVIEWED AND CONSIDERED

10. I have reviewed the '200 patent, its prosecution history, and the prior art and other documents and materials cited herein. For ease of reference, the full list of documents that I have considered is in Appendix A: Materials Considered. I have also considered the documents cited and referenced herein, even if not included in the exhibit list below. Each of these exhibits is a type of document that experts in my field would have reasonably relied upon when forming their

opinions and would have had access to either through the applicable patent office and/or well-known libraries, conferences, publications, organizations, and websites in the field as further discussed herein.

11. My opinions, as explained below, are based on my years of education, research, experience, and background in the field of design and fabrication of planar antennas and their application in compact-format packages as well as my investigation and study of relevant materials for this declaration. When developing the opinions set forth in this declaration, I assumed the perspective of a person having ordinary skill in the art, as set forth in Section VI below. In forming my opinions, I have studied and considered the materials identified in the table in Appendix A.

12. I am an expert in the field of antenna design and analysis with over two decades of experience spanning both academic research and industrial applications. My work has encompassed a wide range of antenna technologies, including planar, conformal, broadband, phased array, and near-field measurement systems. I have designed and optimized antennas for use in wireless communications, radar, medical devices, and sensing systems, often operating across challenging frequency regimes including UHF, microwave, and millimeter-wave bands. My academic contributions include numerous peer-reviewed

publications on antenna characterization, impedance matching, radiation pattern synthesis, and electromagnetic simulation techniques.

13. Throughout my career, I have applied experimental, theoretical and computational methods to solve design antenna problems. This includes the use of full-wave electromagnetic solvers, analytical modeling, and inverse design approaches for optimizing radiation performance under real-world constraints. I have also developed and implemented measurement systems for validating antenna performance in both near-field and far-field configurations. In particular, I have led efforts to enhance near-field scanning and NF-to-FF transformations, which are essential for characterizing large or high-frequency antennas in compact environments. These efforts have resulted in measurable improvements in characterization accuracy and throughput.

14. In addition to my technical work, I have served as a consultant and expert in matters involving antenna system performance, electromagnetic interference, and regulatory compliance. I have evaluated antenna-related claims in the context of intellectual property, product validation, and system interoperability. My combination of hands-on design experience, rigorous analysis capabilities, and familiarity with industry standards enables me to provide technically sound, legally defensible opinions on antenna-related technologies. I am a co-founder of ANTENNEX, B.V. (Eindhoven, Netherlands), which develops new

characterization technologies for (especially) integrated antennas used in wireless devices, such as those in the patent.

III. MY UNDERSTANDING OF PATENT LAW

15. In developing my opinions, I discussed various relevant legal principles with Petitioners' attorneys. I understood these principles when they were explained to me and have relied upon such legal principles, as explained to me, in the course of forming the opinions set forth in this declaration. My understanding in this respect is as follows:

16. I understand that "*inter partes* review" (IPR) is a proceeding before the United States Patent & Trademark Office for evaluating the patentability of an issued patent's claims based on prior-art patents and printed publications.

17. I understand that, in this proceeding, Petitioner has the burden of proving that the challenged claims of the '200 patent are unpatentable by a preponderance of the evidence. I understand that "preponderance of the evidence" means that a fact or conclusion is more likely true than not true.

18. I understand that, in IPR proceedings, claim terms in a patent are given their ordinary and customary meaning as understood by a person of ordinary skill in the art ("POSA") in the context of the entire patent and its prosecution history. If the specification or prosecution history provides a special definition for a claim term that differs from the meaning the term would otherwise possess, that

special definition applies. If a claim element is expressed as a “means” for performing a specified function, I understand that it covers the corresponding structure described in the specification and equivalents of the described structure. I have applied these standards in preparing the opinions in this declaration.

19. I understand that determining whether a particular patent or printed publication constitutes prior art to a challenged patent claim can require determining the effective filing date (also known as the priority date) to which the challenged claim is entitled. I understand that for a patent claim to be entitled to the benefit of the filing date of an earlier application to which the patent claims priority, the earlier application must have described the claimed invention in sufficient detail to convey with reasonable clarity to the POSA that the inventor had possession of the claimed invention as of the earlier application’s filing date. I understand that a disclosure that merely renders the claimed invention obvious is not sufficient written description for the claim to be entitled to the benefit of the filing date of the application containing that disclosure.

20. I understand that for an invention claimed in a patent to be patentable, it must be, among other things, new (novel—or in other words not anticipated) and not obvious from the prior art. My understanding of these two legal standards is set forth below.

A. Anticipation

21. I understand that, for a patent claim to be “anticipated” by the prior art (and therefore not novel), each and every limitation of the claim must be found, expressly or inherently, in a single prior-art reference. I understand that a claim limitation is disclosed for the purpose of anticipation if a POSA would have understood the reference to disclose the limitation based on inferences that a POSA would reasonably be expected to draw from the explicit teachings in the reference when read in light of the POSA’s knowledge and experience.

22. I understand that a claim limitation is inherent in a prior art reference if that limitation is necessarily present when practicing the teachings of the reference, regardless of whether a person of ordinary skill recognized the presence of that limitation in the prior art.

B. Obviousness

23. I understand that a patent claim may be unpatentable if it would have been obvious in view of a single prior-art reference or a combination of prior-art references.

24. I understand that a patent claim is obvious if the differences between the subject matter of the claim and the prior art are such that the subject matter as a whole would have been obvious to a person of ordinary skill in the relevant field at

the time the invention was made. Specifically, I understand that the obviousness question involves a consideration of:

- the scope and content of the prior art;
- the differences between the prior art and the claims at issue;
- the knowledge of a person of ordinary skill in the pertinent art; and
- if present, objective factors indicative of non-obviousness, sometimes referred to as “secondary considerations.” To my knowledge, the Patent Owner has not asserted any such secondary considerations with respect to the ’200 patent.

25. I understand that in order for a claimed invention to be considered obvious, a POSA must have had a reason for combining teachings from multiple prior-art references (or for altering a single prior-art reference, in the case of obviousness in view of a single reference) in the fashion proposed.

26. I further understand that in determining whether a prior-art reference would have been combined with other prior art or with other information within the knowledge of a POSA, the following are examples of approaches and rationales that may be considered:

- combining prior-art elements according to known methods to yield predictable results;

- simple substitution of one known element for another to obtain predictable results;
- use of a known technique to improve similar devices in the same way;
- applying a known technique to a known device ready for improvement to yield predictable results;
- applying a technique or approach that would have been “obvious to try,” such as choosing from a finite number of identified, predictable solutions, with a reasonable expectation of success.
- known work in one field of endeavor may prompt variations of it for use in either the same field or a different one based on design incentives or other market forces if the variations would have been predictable to one of ordinary skill in the art;
- some teaching, suggestion, or motivation in the prior art that would have led one of ordinary skill to modify the prior-art reference or to combine prior-art reference teachings to arrive at the claimed invention. I understand that this teaching, suggestion or motivation may come from a prior-art reference or from the knowledge or common sense of one of ordinary skill in the art.

27. I understand that a universal motivation known in a particular field to improve technology can provide a motivation to combine prior art references even

without any hint or suggestion in the references themselves. I also understand that obviousness is determined in light of all the facts and that a given course of action often has simultaneous advantages and disadvantages, and that this does not necessarily obviate motivation to combine teachings from multiple references.

28. I understand that for a single reference or a combination of references to render the claimed invention obvious, a POSA must have been able to arrive at the claimed invention by modifying, implementing, or combining the teachings of the applied references.

C. Claim Interpretation

29. I understand that determining whether a claimed invention is novel and non-obvious requires comparing the prior art to the claims. In this section, I discuss the interpretations I have applied to certain claim terms in my analysis.

30. I have been informed that patent claims are construed from the viewpoint of a person of ordinary skill in the art at the time of the alleged invention. I have been informed that patent claims generally should be interpreted consistent with their plain and ordinary meaning as understood by a person of ordinary skill in the art in the relevant time period (at the time of the purported invention, or the so called “effective filing date” of the patent application), after reviewing the patent claim language, the specification, and the prosecution history (the intrinsic record).

31. I have further been informed that a person of ordinary skill in the art must read the claim terms in the context of the claim itself, as well as in the context of the entire patent specification. I understand that in the specification and prosecution history, the patentee may specifically define a claim term in a way that differs from the plain and ordinary meaning. I understand that the prosecution history of the patent is a record of the proceedings before the U.S. Patent and Trademark Office and may contain explicit representations or definitions made during prosecution that affect the scope of the patent claims. I understand that an applicant may, during the course of prosecuting the patent application, limit the scope of the claims to overcome prior art or to overcome an examiner's rejection, by clearly and unambiguously arguing to overcome or distinguish a prior art reference, or to clearly and unambiguously disavow claim coverage.

32. In interpreting the meaning of the claim language, I understand that a person of ordinary skill in the art may also consider "extrinsic" evidence, including expert testimony, inventor testimony, dictionaries, technical treatises, other patents, and scholarly publications. I understand this evidence is considered to ensure that a claim is construed in a way that is consistent with the understanding of those of skill in the art at the time of the alleged invention. This can be useful for technical terms whose meaning may differ from its ordinary English meaning. I understand that extrinsic evidence may not be relied on if it contradicts or varies the meaning

of claim language provided by the intrinsic evidence, particularly if the applicant has explicitly defined a term in the intrinsic record.

33. I understand that determining whether a claimed invention is novel and non-obvious requires comparing the prior art to the challenged claim. In this Declaration, I apply the above standards to the terms in the challenged claims. The meanings of specific terms are discussed below in connection with evaluating the disclosure in the priority documents.

IV. DESCRIPTION OF THE RELEVANT FIELD AND THE RELEVANT TIMEFRAME

34. I have reviewed the '200 patent (EX1003) and its prosecution history (EX1004).

35. I have been instructed by Petitioners' counsel to assume that there are **three** relevant timeframes for evaluating the prior art.

- a. *First*, I am told to assume that the relevant timeframe for my analysis of the prior art in **Ground 1**, e.g., Dou and Jing (discussed below), is **on or before June 19, 2006**.
- b. *Second*, as I explain for **Ground 2** below, I was asked to form an opinion concerning how a POSA would have understood the disclosures in the '429 application when it was filed on **December 21, 2006**.

c. *Third*, I am told to assume that the relevant timeframe for my analysis of the prior art in **Ground 2** (e.g., Baliarda-543) is **no earlier than April 7, 2014**.

36. Based on my review of this material, I believe that the relevant general field for the purposes of the '200 patent is wireless communication devices with integrated antennas. The '200 patent pertains to the field of wireless communication devices—specifically, to portable, handheld terminals (e.g., smartphones, multimedia devices) that incorporate multiple-body configurations (such as clamshells, sliders, or pivoting devices) and integrated multi-band antenna systems for operation across cellular and other wireless bands.

37. This field includes: Electromagnetic and antenna design for handheld, compact, multi-body devices; Physical form factor integration of RF components to support multi-frequency operation (e.g., GSM, LTE, Wi-Fi, GPS, Bluetooth).

V. UNPATENTABILITY GROUND

38. I have considered these unpatentability Grounds:

Ground	Reference(s)	Claims	Basis
1	Dou, Jing	1-15, 17, 19-20	obviousness
2	Baliarda-543	1-20	anticipation/obviousness

39. I have been instructed by Petitioners' counsel to assume that Dou (EX1013), Jing (EX1011), and Baliarda-543 (EX1040) are each prior art to the Challenged Claims addressed in each respective Ground.

VI. PERSON OF ORDINARY SKILL IN THE ART (“POSA”)

40. I have been informed and understand that for purposes of assessing whether prior art references disclose every element of a patent claim (thus “anticipating” the claim) and/or would have rendered the claim obvious, the patent and the prior art references must be assessed from the perspective of a person having ordinary skill in the art (“POSA”) to which the patent is related, based on the understanding of that person at the time of the patent claim’s priority date.

41. I have been informed and understand that various factors may be considered in assessing the level of a POSA, including (1) educational level of the inventor; (2) type of problems encountered in the art; (3) prior art solutions to those problems; (4) rapidity with which innovations are made; (5) sophistication of the technology, and (6) educational level of workers active in the field. I have also been informed and understand that not all of these factors may be present in every case, and one or more of these or other factors may predominate in a particular case. I have further been informed and understand that these factors are not exhaustive but are merely a guide to determining the level of ordinary skill in the art. I have applied this standard throughout my declaration.

42. The ’200 patent involves technology in the field of in the field of portable, handheld terminals (e.g., smartphones, multimedia devices) that incorporate multiple-body configurations (such as clamshells, sliders, or pivoting

devices) and integrated multi-band antenna systems for operation across cellular and other wireless bands. *See* EX1003, *passim*. I have been asked to provide my opinions as to the state of the art in this field before June 19, 2006. I use this time frame because I have been informed by counsel that Patent Owner Fractus's earliest-alleged conception date is June 19, 2006.

43. Fractus has defined a POSA as follows:

[A] person with at least a bachelor's degree in electrical engineering, computer science, or a similar degree and at least four years of experience in applied electromagnetics with an emphasis on antennas. Alternatively, the person of ordinary skill in the art would have a master's degree in electrical engineering (or similar discipline) and at least two years of similar experience.

EX1018, 8-9, ¶32. I agree with this definition of a POSA and have applied the above definition of a POSA in this declaration.

44. The basis for my familiarity with the level of ordinary skill is my own technical experience and my interaction with students and professionals in the field of compact, broadband planar antennas (and the field of antenna design more broadly) who were at this level of skill as of June 2006. I am well-aware of the knowledge that a POSA would have had at the time this patent was written as I have been actively consulting, teaching, and carrying out research with such students and collaborators in these fields for approximately 15 years prior to June 2006.

45. My opinion identifying the POSA's level of ordinary skill is consistent with the problems encountered in the art, the prior art solutions to those problems, the rapidity with which innovations are made, the sophistication of the technology, and the educational level and professional capabilities of workers in the field. This is shown, among other things, by the prior art references described in the Grounds below.

46. By June 2006, the field of wireless communication devices—particularly handheld multimedia terminals and smartphones—had matured significantly. Manufacturers routinely confronted the challenge of integrating multi-band antennas into compact, user-friendly enclosures. A key problem was maintaining acceptable radio-frequency (RF) performance despite increasingly complex and miniaturized form factors, such as clamshells, sliders, and swiveling devices. These configurations often altered the electromagnetic environment in which antennas operated, introducing detuning effects and radiation pattern variability.

47. To address these challenges, the prior art included several approaches for integrating internal antennas within multi-body devices, as I discuss in detail below. Designers employed planar inverted-F antennas (PIFAs), monopoles, fractal geometries, and multi-feed structures to achieve broadband and multiband operation. Techniques such as antenna diversity, adaptive impedance matching,

and spatial separation were well known to mitigate interference and optimize performance. The prior-art references I assert (alone or in combination), as well as numerous publications and commercial devices, demonstrate that antenna geometry could be adjusted parametrically to control metrics such as bandwidth, return loss, and gain across varying device orientations and enclosures.

48. The field of mobile RF antenna integration progressed rapidly during the 2000s and 2010s, fueled by intense commercial competition and evolving wireless standards (e.g., GSM, UMTS, LTE, Wi-Fi, Bluetooth, GPS). Each new smartphone generation typically introduced novel mechanical designs and antenna layout strategies to accommodate additional frequency bands, more transceivers, and evolving SAR (specific absorption rate) requirements. Academic and industrial research routinely reported new methods for compact, multiband antennas using simulation-driven optimization, materials engineering, and hybrid mechanical-electromagnetic co-design.

49. Simulation tools such as CST Microwave Studio, HFSS, and ADS Momentum became standard in the design process, allowing engineers to evaluate full-wave 3D antenna performance under a variety of boundary conditions, including open and closed device states. The field demanded a high level of integration between industrial design, RF engineering, and mechanical packaging,

and it attracted a globally competitive workforce pushing continuous incremental improvements.

50. By June 2006, I possessed at least the level of skill of a POSA to which the '200 patent is directed.

51. I have worked with many people who fit the characteristics of the POSA, and I am familiar with their level of skill in and around June 2006. When developing the opinions set forth in this declaration, I assumed the perspective of a POSA as set forth above

52. For **Ground 1**, except as noted below, whenever I offer an opinion in this declaration about the knowledge of a POSA, the manner in which a POSA would have understood the claims of the '200 patent or its description, the manner in which a POSA would have understood the prior art, or what a POSA would have been led to do based on the prior art, I am referencing the June 2006 timeframe, even if I do not say so specifically in each case.

53. For **Ground 2**, following instructions from Petitioners' counsel, I evaluate the evidence from the POSA's perspective on two different dates.

54. *First*, when evaluating the written disclosure in U.S. Patent Application No. 11/614,429 ("the '429 application" published as Baliarda-543 (EX1040)), whenever I offer an opinion in this declaration about the knowledge of a POSA, the manner in which a POSA would have understood the claims of the

'200 patent or its description, the manner in which a POSA would have understood the prior art, or what a POSA would have been led to do based on the prior art, I am using the POSA's perspective on **December 21, 2006**—the '429 application's filing date—even if I do not say so specifically in each case.

55. *Second*, when evaluating the disclosure in Baliarda-543 as compared to the scope and content of Challenged Claims 1-20, I am using the POSA's perspective on or before **April 7, 2014**, even if I do not say so specifically in each case.

VII. '200 PATENT¹

56. The '200 patent concerns a “multifunction wireless device” with “smartphone functionality” that has an “antenna system.” The antenna system is disposed “within” the device and comprises a “ground plane” and “first” and “second” antennas. The specification describes a wireless device having multiband antennas (antennas covering multiple frequency ranges associated with communication standards), and having antennas that cover different frequency ranges. EX1003, 9:59-10:39, 25:14-30, 25:61-26:5.

57. The '200 patent states that the wireless device is preferably capable of communicating (has “wireless connectivity”) using several different

¹ Throughout this Declaration all emphasis is added unless otherwise indicated.

communication standards that use frequency bands in several different frequency ranges. EX1003, 9:59-10:39, 25:14-30, 25:61-26:5. Thus, the '200 patent describes using antennas, including multiband antennas, that are designed to send and receive electromagnetic signals in frequency ranges used by the frequency bands for these communication standards. EX1003, 12:34-36 (“A structure of [the invention’s] antenna system... is able to support different radiation modes.”), 13:35-38 (“The resulting antenna structure... includes a plurality of portions that allow the operation of the antenna system in multiple frequency bands.”).

58. The '200 patent asserts that the antenna system’s design “is intended to use efficiently as much of the volume” within a defined space “in order to obtain a superior RF performance... in at least one frequency band.” EX1003, 14:1-6. The patent refers to the resulting antenna structure’s “geometrical complexity” (EX1003, 14:10-20) and characterizes an antenna design’s “level of complexity” in terms of “complexity factor”—which the specification defines as a mathematical calculation based on antenna dimensions using specific analytic steps, as explained below §VIII (claim construction).

59. The patent asserts,

In accordance with embodiments of the invention, *the level of complexity of an antenna contour can be advantageously parameterized by means of two complexity factors*, hereinafter referred to as F_{21} and F_{32} , which capture and characterize certain aspects of the

geometrical details of the antenna contour (such as for instance its edge-richness, angle-richness and/or discontinuity-richness) when viewed at different levels of scale.

EX1003, 16:64-17:4.

60. The patent asserts that “[c]omplexity factor F_{21} is related to the number of paths that [an antenna system] structure... provides to electric currents... to excite radiation modes.... In general, the more frequency bands and/or radiation modes that need to be supported by the antenna structure... the higher the value of F_{21} that needs to be attained.” EX1003, 19:49-61. The patent suggests that an “antenna contour” with “complexity factor F_{32} larger than a certain minimum value” will “achieve some degree of miniaturization” but may have “reduced capability to operate in multiple frequency bands and/or limited RF performance.” EX1003, 20:61-21:6. The specification asserts that “effective antenna design” is achieved by specifying antenna complexity factors using any combination of F_{32} values between 1.10 and 1.90 in 0.05 increments, and F_{21} values between 1.05 and 1.80 in 0.05 increments. EX1003, 21:11-26.

61. The specification shows a single example of an antenna design, e.g., an “antenna contour” reflecting a physical antenna layout (Figs. 12A, 17H), with a known frequency response (Fig. 19A), that the patent also evaluates for “*complexity factor*” (EX1003, 38:66-40:67).

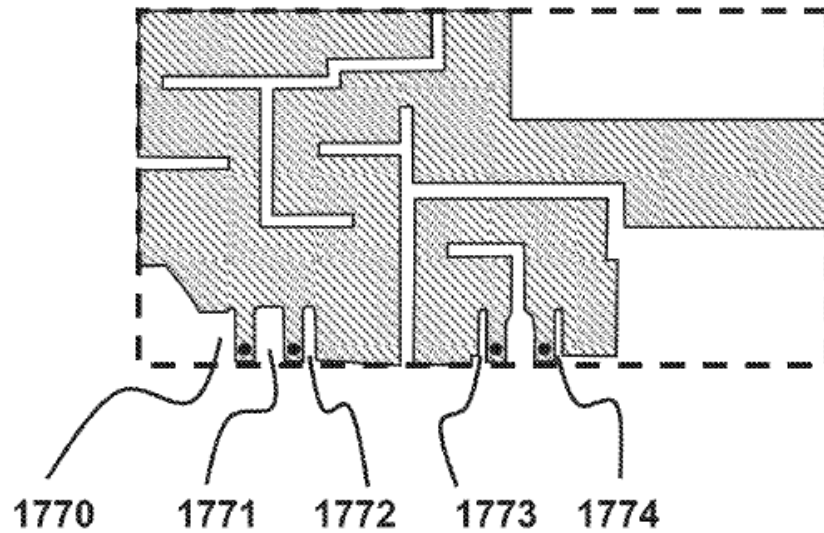

FIG. 17H

62. This antenna covers—meaning it can send and receive electromagnetic signals at—radio frequencies that are compatible with GSM and UMTS communication standards. EX1003, Fig. 19A, 38:66-39:46, 41:3-41:31. The operable frequency ranges are determined at a given voltage standing wave ratio (VSWR), a design parameter that measures how well the antenna works with the device electronics (e.g., transceiver) that send and receive electrical signals that the antenna converts to RF radiation. EX1003, 2:3-5.

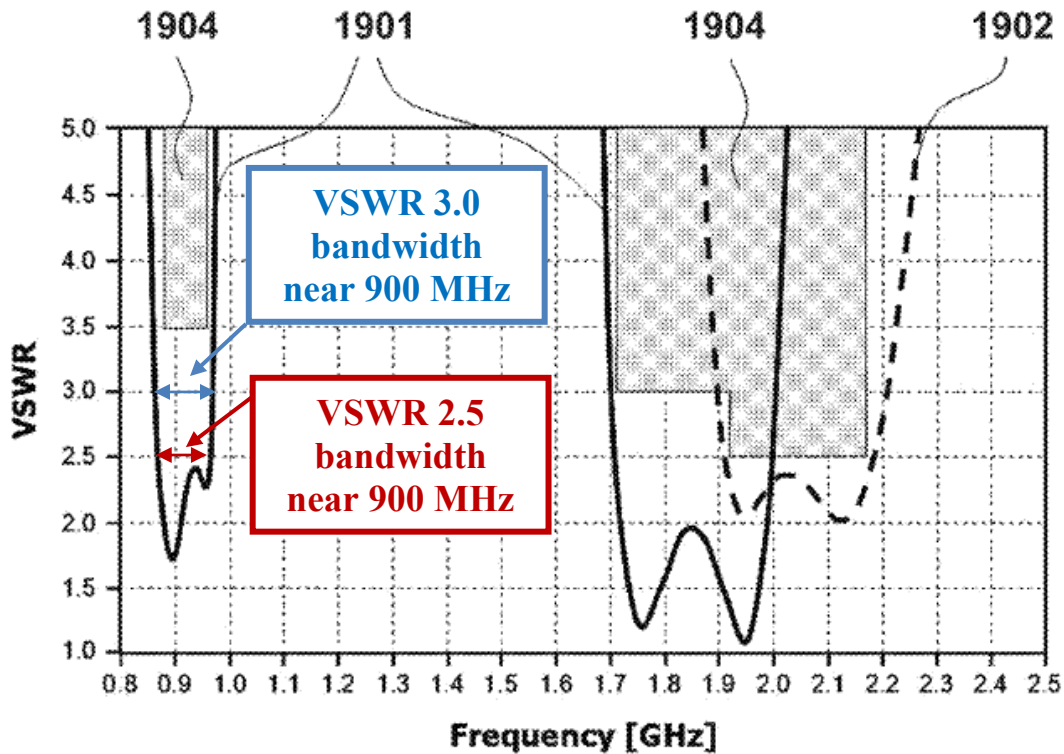

FIG. 19A

63. A *lower* VSWR means *a better match* between the antenna and the device electronics (e.g., transceiver), making the system more efficient at radiating energy: a perfect match has VSWR 1:1. Figure 19A shows that lower VSWR is associated with a smaller frequency range, illustrating a well-known tradeoff between impedance match (e.g., VSWR) and antenna bandwidth. The specification describes “maximum” VSWR values for frequency ranges associated with GSM and UMTS communication standards (EX1003, 37:22-52, Table 1), and Figure 19A shades regions with VSWR above the specification’s “maximum”

levels at different frequency ranges used with different communication standards.

EX1003, 41:11-17.

64. While the specification describes “complexity factors” for each step of “progressive modification” of an antenna contour from Figure 17A-17H (EX1003, 39:10-41:2, Table 2), the patent never shows the antenna performance—e.g., frequency response—associated with each “progressive modification” or that antenna’s “complexity factors.”

A. Challenged Claims

65. The '200 patent has 20 claims, each concerning a “wireless device.” Appendix B provides a claim list. Claims 1, 6, and 11 are independent.

66. Claim 1 recites “*wireless device*” comprising an “*antenna system*” ([1.PRE]-[1.a]). The “*antenna system*” comprises “*a ground plane*” ([1.a]) and a “*first*” ([1.b]) and “*second antenna*” ([1.g]). The “*first antenna*” comprises a “*first antenna contour*” with “*complexity factor F_{21}* ” being “*at least 1.20*” and “*complexity factor F_{32}* ” being “*less than 1.35*” ([1.f]). Claims 6 and 11 recite additional limitations concerning first/second antenna frequency coverage, placement, or shape.

67. Dependent claims add further limitations concerning additional antennas and the shape, frequency coverage, and placement for the various antennas.

VIII. CLAIM INTERPRETATION

68. I apply relevant claim constructions below in relation to the claim elements in which they appear. Where I do not discuss a particular claim construction, I apply the ordinary meaning that the claim term would have had to a POSA at the time of invention.

69. I understand that the '200 patent expressly defines several claim terms—e.g., “*antenna contour*,” “*complexity factor*,” and others—whose construction is discussed below.

70. I also understand that in litigation with ADT, Fractus argued constructions for (and the court construed) common claim terms from the '200 patent. EX1020, 1; EX1003, code (63).

71. In forming my opinions, I applied the claim constructions described below, as directed by Petitioners' counsel.

A. “*perimeter*” (all claims)

72. In the ADT Litigation, the court rejected Fractus's proposed construction and construed “*perimeter*” as: “boundary of an object” ***excluding*** “any notion of ‘following the shape of the radiating element and extending it as necessary to complete the boundary.’” EX1020, 14-17; EX1021. The ADT court's construction of “*perimeter*” comports with the ordinary meaning. In my opinion, a

POSA would have agreed with the court’s construction of “*perimeter*” in the ADT litigation.

B. “*antenna box*” (claims 2, 6-20)

73. The ’200 patent says that Fig. 1B’s element 103 shows an “antenna box,” which the patent defines as:

the minimum-sized parallelepiped of square or rectangular faces that completely encloses the antenna volume of space and wherein each one of the faces of the minimum-sized parallelepiped is tangent to at least one point of the volume. Moreover, each possible pair of faces of the minimum-size parallelepiped shares an edge forming an inner angle of 90°.

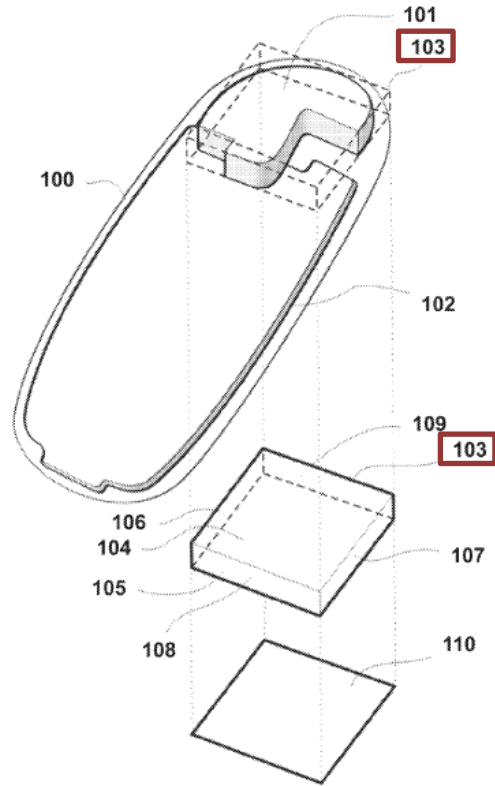

FIG. 1B

EX1003, Fig. 1B, 11:35-49.

C. “*antenna rectangle*” (claims 2-3, 6-20)

74. The ’200 patent defines an “antenna rectangle” as “the orthogonal projection of the antenna box [] along the normal to the face with largest area [of the antenna box].” EX1003, 27:20-23.

D. “antenna contour” (all claims)

75. The '200 patent says that Figure 3 shows an “antenna contour” 350 (blue outline below) for “antenna element 300” within “antenna rectangle” 351 (supra §VIII.C) formed from an orthogonal projection through “antenna box” 301 (supra §VIII.B). EX1003, Fig. 3 (annotated below), 27:20-23, 27:57-28:17.

76. The “antenna contour” 350 comprises “disjointed subsets of segments” from “perimeter 357” (supra §VIII.A), “segments 356 corresponding to the orthogonal projection of part 306,” and “segments” 352/353 “associated to the perimeter of aperture[s]” 302/303, respectively. EX1003, 27:62-28:17.

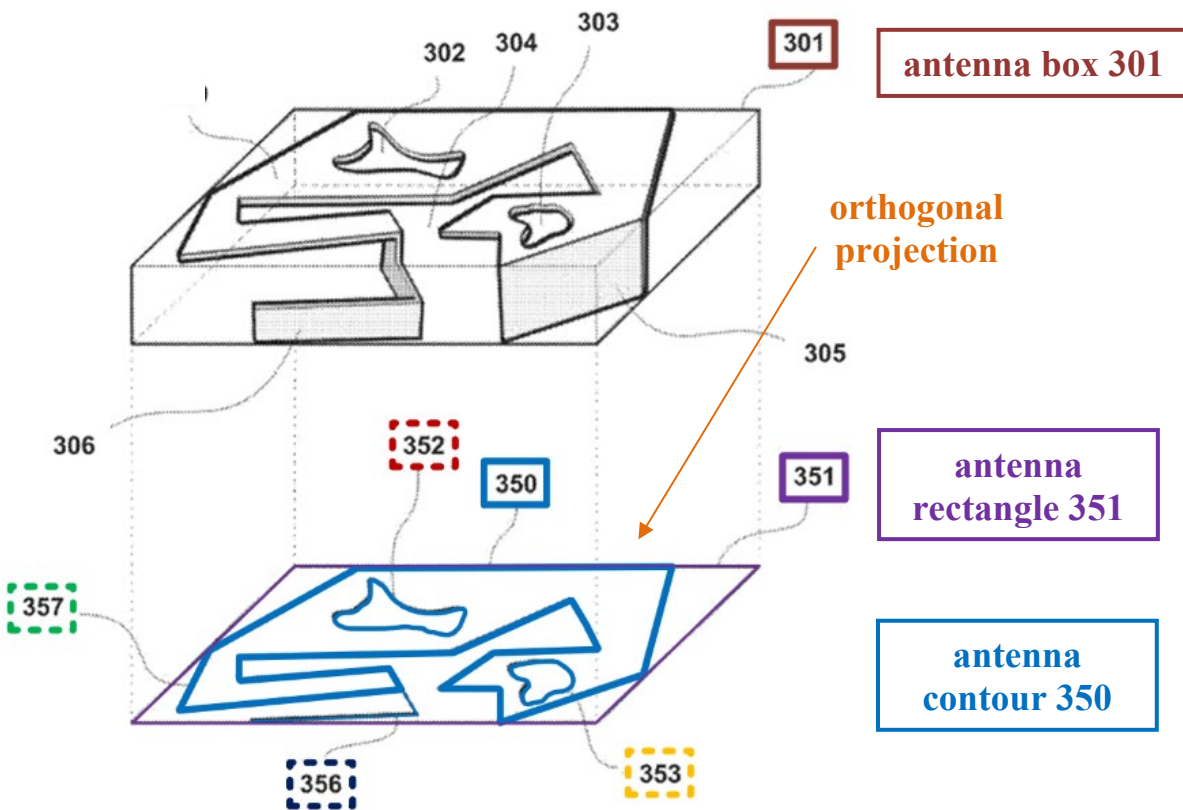

EX1003, Fig. 3 (annotated)

77. The '200 patent states, “[t]he antenna contour of the antenna system is a set of joined and/or disjointed segments comprising” (with numbering added):

[1] *the perimeter* of one or more antenna elements *placed in the antenna rectangle*,

[2] *the perimeter* of closed slots and/or closed apertures defined within the antenna elements, and/or [3] the *orthogonal projection onto the antenna rectangle* of *perimeters* of antenna elements, or *perimeters* of or parts of antenna elements that are *placed in the antenna box* but not in *the antenna rectangle*.

EX1003, 15:16-37 (“Not all the segments that form the antenna contour need to be connected (i.e., to be joined). In some cases, the antenna contour comprises two, three, four or more disjointed subsets of segments.”). Figure 3 shows antenna contour 350 comprising each disjointed subset: [1] *perimeter* 357 and projection 356, [2] *perimeter* 352, and [3] *perimeter* 353. EX1003, Fig. 3 (annotated detail below).

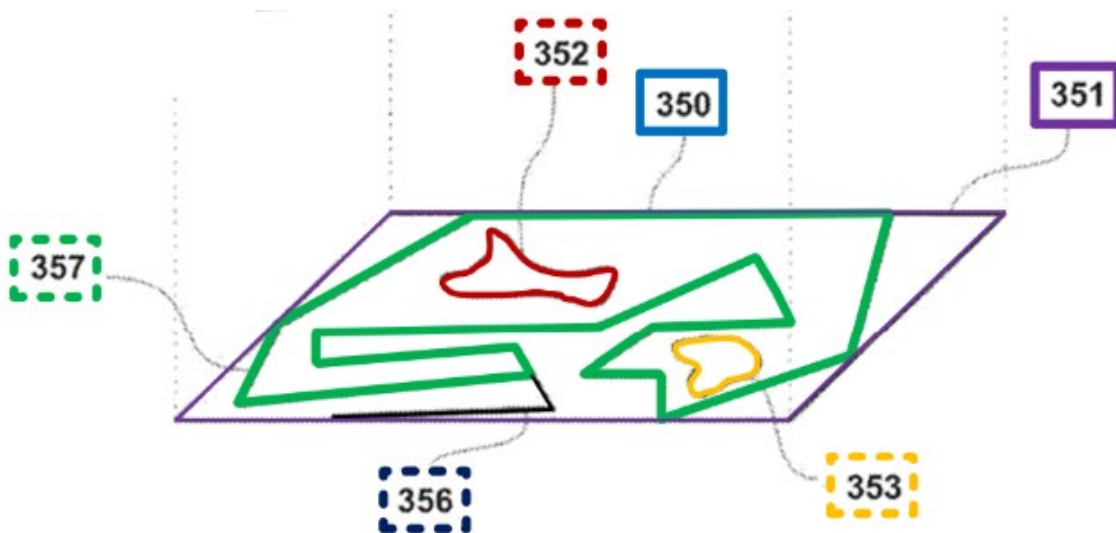

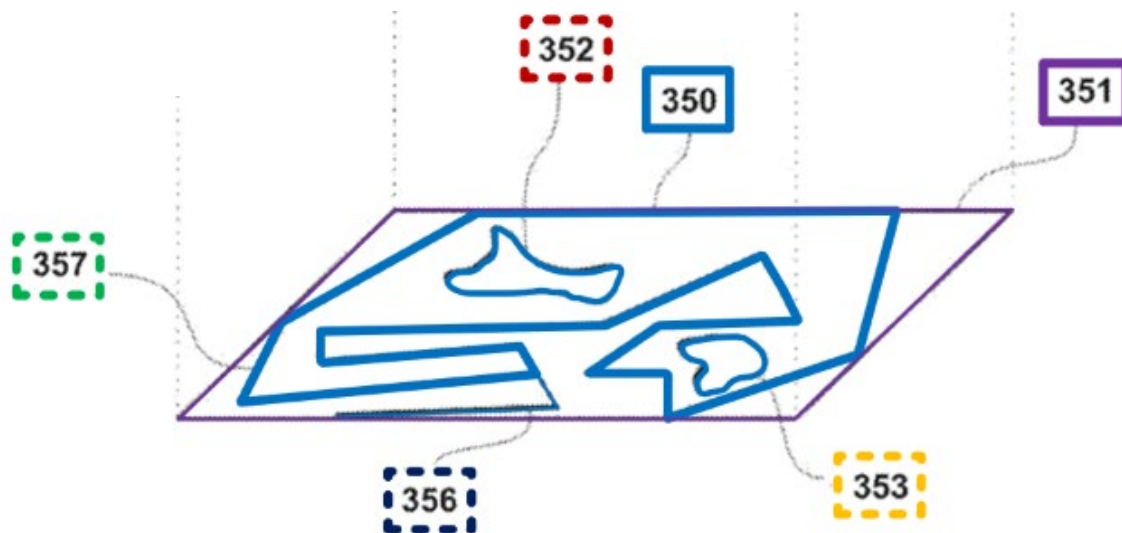

E. “complexity factor,” “ F_{21} ,” “ F_{32} ” (all claims)

78. Every claim recites a “complexity factor.” The ’200 patent says that “complexity factor” is a number that characterizes an “antenna contour.” EX1003, 16:64-17:4; *supra* §VIII.D.

79. The “complexity factors F_{21} ” and “ F_{32} ” have no ordinary meaning in the art. The ’200 patent specification defines these factors as the numerical result of a calculation based on operations involving overlaying a series of three specifically-formulated grids (G_1 , G_2 , and G_3 , respectively) on the “antenna rectangle”—thereby overlaying an “antenna contour”—as explained below. EX1003, 17:5-15.

1. Grids

80. The '200 patent states that “[g]rids G_1 and G_3 are constructed from grid G_2 [.]” EX1003, 17:26-27. The choice of the second grid dimensions (rows and columns) thus determines the first and third grid dimensions as shown below.

a. Second Grid G_2

81. The second grid G_2 cell size and aspect ratio—“the ratio between [cell] width and... height”—are chosen to “perfectly tessellate[.]” the “*antenna rectangle*” with “an odd number of columns and an odd number of rows.” EX1003, 17:28-32. The specification associates the *antenna rectangle*’s long side (i.e., “width”) with grid *columns* and the short side (i.e., “height”) with grid *rows*. EX1003, 17:33-56.

82. Each grid has “substantially square or rectangular cells” (EX1003, 17:5-15), wherein if “two different combinations of a number of columns and a number of rows of cells of the second grid produce a cell as square as possible, a second grid is selected such that the aspect ratio”—the ratio of cell width to cell height—“is larger than 1.” EX1003, 17:65-18:7. The closer the cell’s aspect ratio is to 1 (e.g., wherein the height and width of the cell are the same), the closer the cell is to square.

83. The '200 patent says Figure 14B shows a “second grid” 1402 “tessellat[ing]” antenna rectangle 1400 with 9 columns and 5 rows. EX1003, Fig. 14B (annotated below), 34:53-67, 35:7-11.

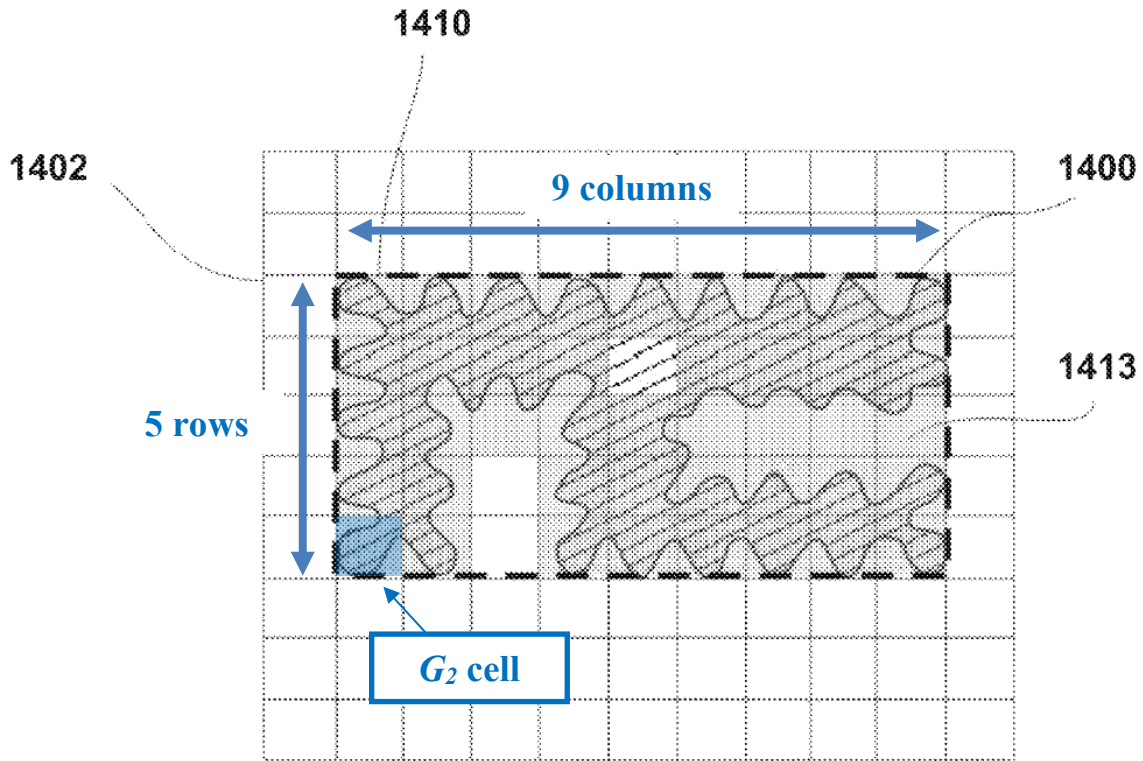

FIG. 14B

b. First Grid G_1

84. The '200 patent states that “[a] first cell of the grid G_1 is... created by grouping four cells of grid G_2 in such a manner that a corner of the first cell is the feeding point corner, and the first cell is positioned completely inside the antenna rectangle.” EX1003, 18:66-19:2.

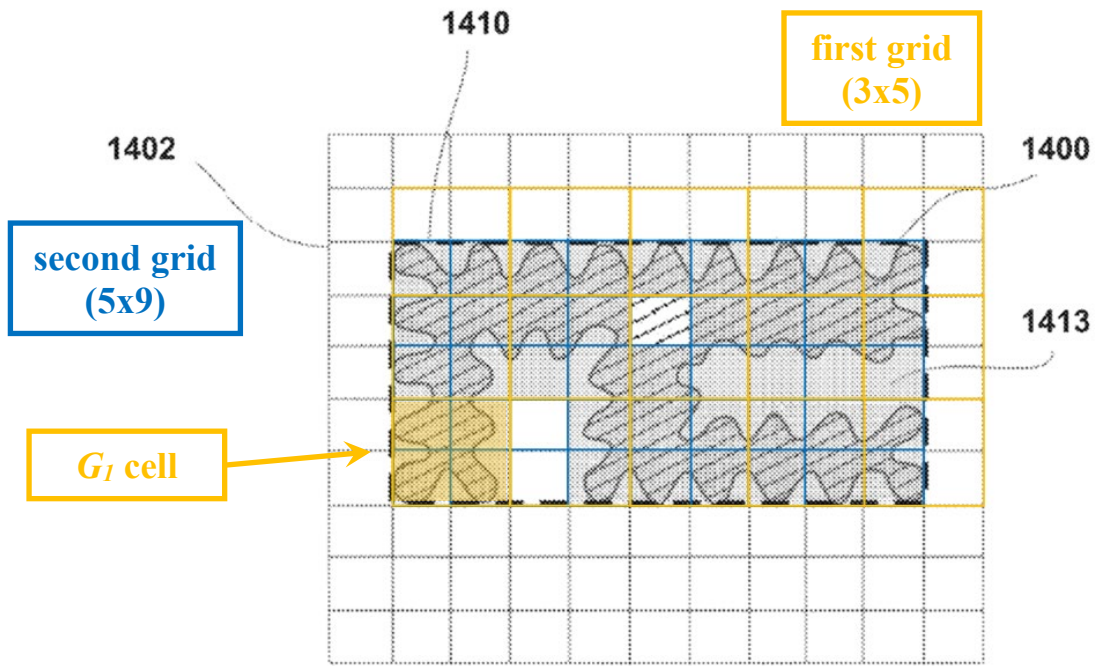

FIG. 14B

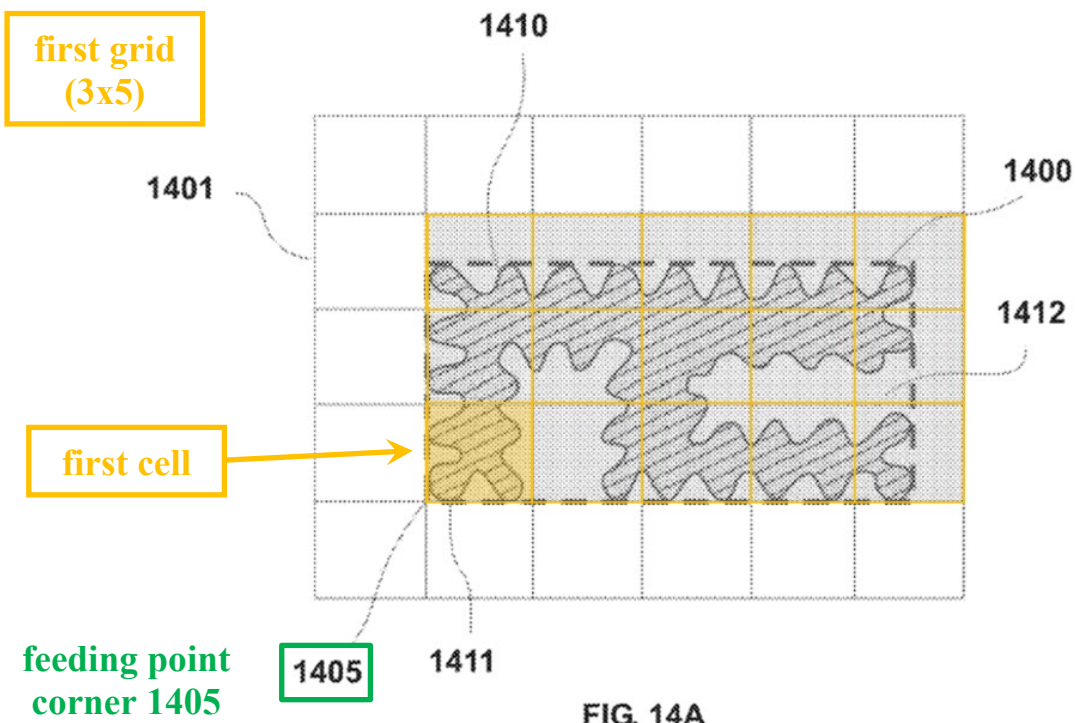
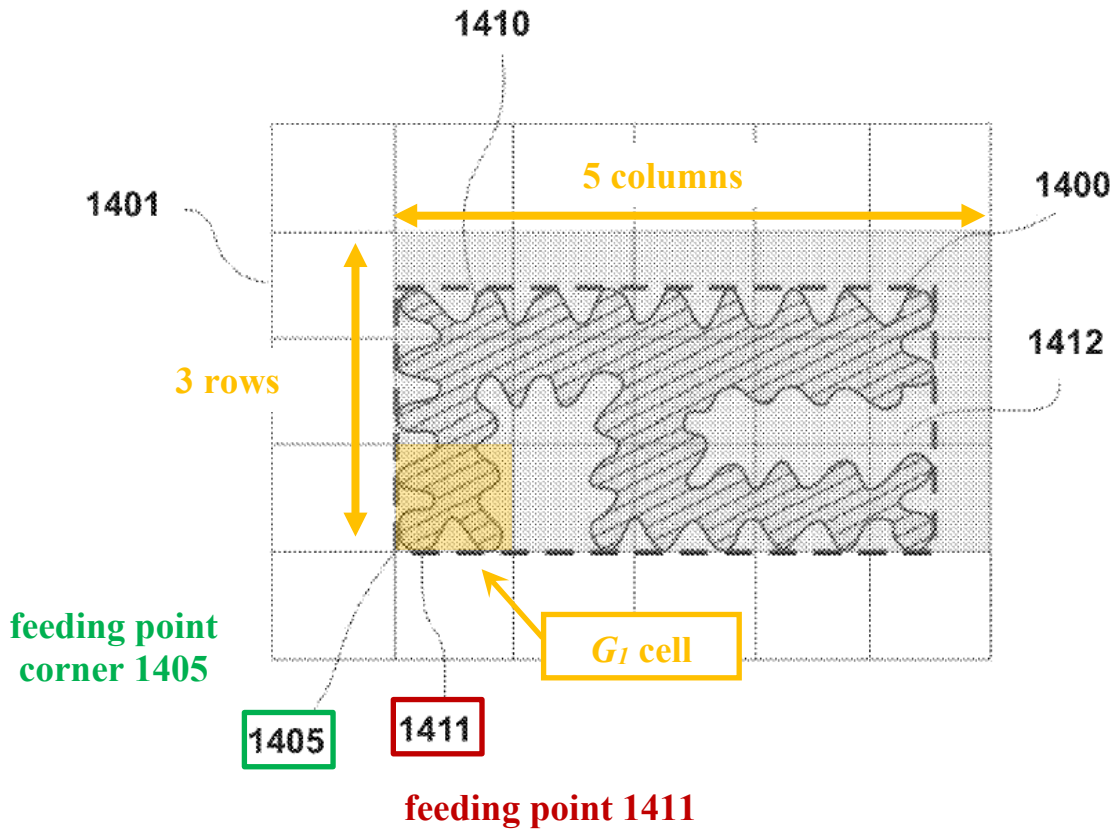

FIG. 14A

85. The patent defines a “feeding point corner” as “the corner of the antenna rectangle closest to the feeding point of the antenna system responsible for the [system’s] operation in its lowest frequency band.” EX1003, 18:27-30. After “placing” the first cell, “other $[G_i]$ cells can be placed uniquely defining the relative position of $[G_i]$ with respect to the antenna rectangle.” EX1003, 19:3-5. As shown below, the relevant cells of a first grid are the minimum set of cells all of the same size as the first cell and encompass the entire antenna contour.



86. The '200 patent says that Figure 14A shows a first grid 1401, with “feeding point 1411, located substantially close to the bottom left corner of the

antenna rectangle 1405 (being thus the feeding point corner).” EX1003, Fig. 14A (annotated above), 34:53-67.

c. Third Grid G_3

87. The third grid (G_3) fits twice as many rows and columns within the *antenna rectangle* as the second grid (G_2), thereby replacing “each cell of... grid G_2 ... with 2-by-2 cells of... grid G_3 [.]” EX1003, 19:62-20:4. Each third grid’s cell has width (W_3) that is half the second grid cell width, and height (H_3) that is half the second grid cell height. *Id.* The ’200 patent states that Figure 14C shows third grid 1403 formed from second grid 1402. EX1003, Figs. 14B, 14C, 34:53-56, 35:12-17.

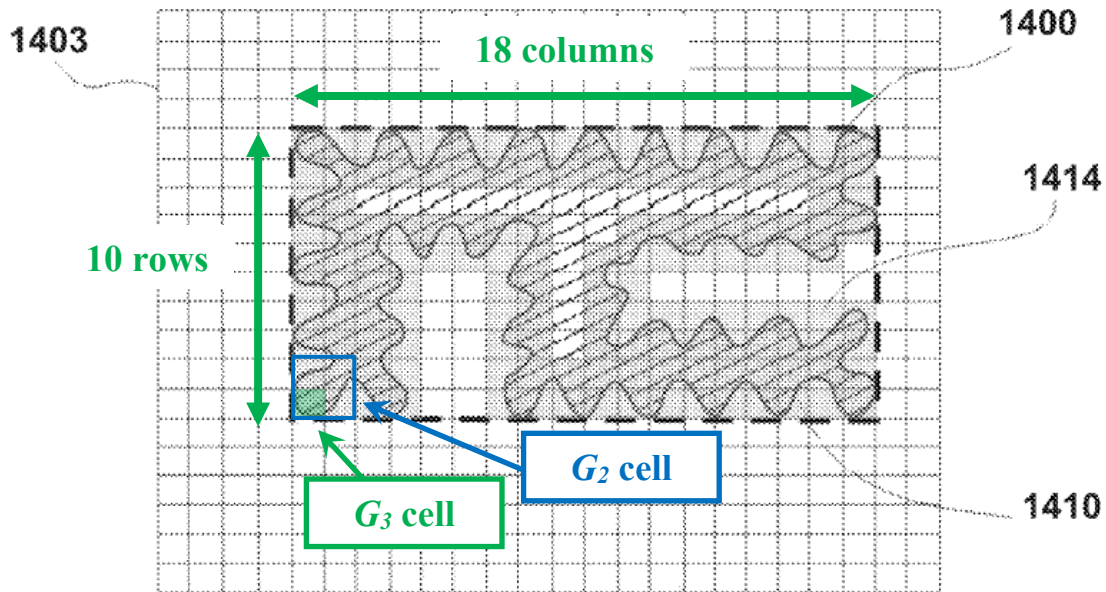

FIG. 14C

2. Calculation

88. The claims recite two “*complexity factors*” named “ F_{21} ” and “ F_{32} .”

The ’200 patent defines each “*complexity factor*” as follows.

a. “ F_{21} ”

89. The ’200 patent computes “ F_{21} ” by:

- [1] counting the number of cells N_1 in grid G_1 that [a] “are at least partially inside the antenna rectangle” and [b] “include at least a point of the antenna contour”; and
- [2] counting the number of cells N_2 in grid G_2 that [a] “are completely inside the antenna rectangle” and [b] “include at least a point of the antenna contour[.]”

EX1003, 19:12-20. The ’200 patent states “in the present invention the boundary of the cell is also part of the cell[.]” EX1003, 19:16-17.

90. The ’200 patent defines *complexity factor* F_{21} as:

$$F_{21} = - \frac{\log(N_2) - \log(N_1)}{\log(1/2)}$$

EX1003, 19:12-25.

91. A POSA would have understood “log” to mean base 10 logarithm. However, since the logarithm in different bases are related by a multiplicative constant, it would not matter what base was used to evaluate this complexity factor equation so long as the same base was used for each logarithm, because the ratio in

the complexity factor equation cancels out the multiplicative factor (highlighted in the examples below). In other words, expressing

$$A = 10^x = 2^y,$$

then

$$\log_{10}(A) = x \log_{10}(10) = x = y \log_{10}(2),$$

and

$$\log_2(A) = x \log_2(10) = y \log_2(2) = y.$$

92. This means, depending on whether the logarithm is base 2 or 10 in this example,

$$x = y \log_{10}(2),$$

$$x \log_2(10) = y$$

93. As a numeric example, suppose $N_2 = 42$ and $N_1 = 15$. Then using a base 10 logarithm,

$$\begin{aligned} F_{21} &= -\left(\frac{\log_{10}(N_2) - \log_{10}(N_1)}{\log_{10}(1/2)}\right) = -\left(\frac{\log_{10}(42) - \log_{10}(15)}{(-1)\log_{10}(2)}\right) \\ &= \left(\frac{\log_{10}(42/15)}{\log_{10}(2)}\right) = \left(\frac{0.447}{0.301}\right) = 1.49. \end{aligned}$$

94. Using a base 2 logarithm gives the same result,

$$F_{21} = -\left(\frac{\log_2(N_2) - \log_2(N_1)}{\log_2(1/2)}\right) = -\left(\frac{\log_2(42) - \log_2(15)}{(-1)\log_2(2)}\right)$$

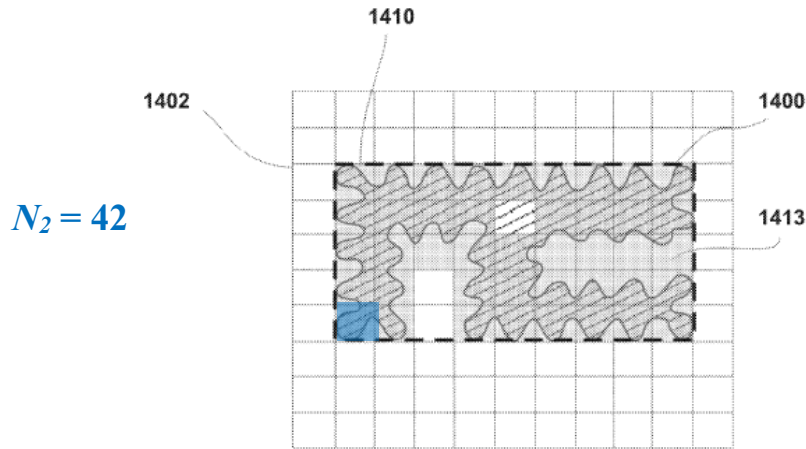

FIG. 14B

97. The complexity factor F_{21} for antenna contour 1410 is thus:

$$\begin{aligned}
 F_{21} &= -\left(\frac{\log(N_2) - \log(N_1)}{\log(1/2)}\right) = -\left(\frac{\log(42) - \log(15)}{(-1)\log(2)}\right) \\
 &= \left(\frac{\log\left(\frac{42}{15}\right)}{\log(2)}\right) = \left(\frac{0.447}{0.301}\right) = 1.49.
 \end{aligned}$$

EX1003, 35:18-24.

98. In performing this calculation, I used the relationship that the logarithm of a product is $\log(AB) = \log(A) + \log(B)$, so that

$$\begin{aligned}
 \log\left(\frac{A}{B}\right) &= \log(A \times B^{-1}) = \log(A) + (-1)\log(B) \\
 &= \log(A) - \log(B).
 \end{aligned}$$

b. “ F_{32} ”

99. The '200 patent computes “ F_{32} ” by further [3] counting the number of cells N_3 in grid G_3 that [a] “are completely inside the antenna rectangle” and [b]

“include at least a point of the antenna contour[.]” EX1003, 20:5-11. The ’200 patent defines *complexity factor* F_{32} as:

$$F_{32} = -\frac{\log(N_3) - \log(N_2)}{\log(1/2)}$$

EX1003, 20:12-16.

100. Using Figure 14’s *antenna contour* 1410, the patent describes a **third grid** (Fig. 14C, 1403) with N_3 =“one hundred and forty-two (142) cells,” shown as shaded group 1414, meeting [3][a]-[b]. EX1003, Figs. 14B-14C, 35:12-17. Unshaded cells in Figure 14C do not meet the G_3 cell counting criteria.

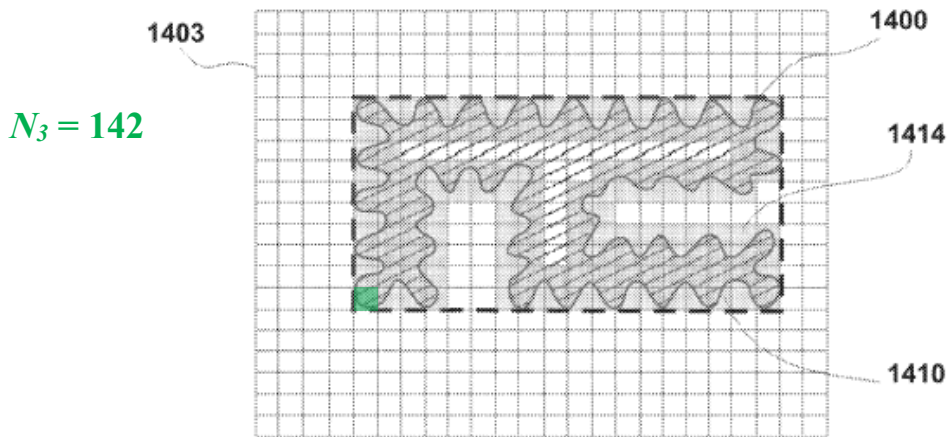

FIG. 14C

101. Using the $N_2 = 42$ result for Figure 14B, the *complexity factor* F_{32} for *antenna contour* 1400 is thus:

$$\begin{aligned} F_{32} &= -\left(\frac{\log(N_3) - \log(N_2)}{\log(1/2)}\right) = -\left(\frac{\log(142) - \log(42)}{(-1)\log(2)}\right) \\ &= \left(\frac{\log(142/42)}{\log(2)}\right) = \left(\frac{0.529}{0.301}\right) = 1.76. \end{aligned}$$

EX1003, 35:25-30.

3. Fractus's ADT Litigation argument

102. In the ADT Litigation, Fractus argued that the '200 patent "explain[s] precisely how to calculate the complexity factors F_{21} and F_{32} [" EX1017, 24. A POSA would have understood that Fractus's ADT Litigation construction concedes that the specification defines "*complexity factor*" and comports with the analysis *supra* §§VIII.E.1-0 applying the specification's instructions.

F. "*wireless device*" (all claims)

103. In the ADT Litigation, Fractus argued (and the court agreed) that "the ordinary meaning of 'wireless device'... refers to the nature of the communication," e.g., that the device communicates wirelessly. EX1020, 11.

G. "*4G communication standard*" (all claims)

104. The claims require antennas capable of operating with a "*4G communication standard*" (claims 1-20): an "*antenna... configured to transmit and receive signals from a 4G communication standard*" (claims 1-5); an "*antenna*

configured operate in... [a] frequency band being used by a 4G communication standard” (claims 6-10); and an “*antenna configured to provide operation in... frequency bands being used by 4G communication standards*” (claims 6-20).

105. As shown below (*infra* §VIII.G.2) Fractus’s litigation arguments take the position that “*4G communication standard*” is met by LTE; an LTE frequency band is “*used by*” a “*4G communication standard*”; and an “*antenna configured to... receive signals from a 4G communication standard*” is met by an antenna covering LTE frequency bands. The prior art in Ground 1 meets these “*4G*” terms under Fractus’s arguments, so that there is no dispute over the meaning of the “*4G*” terms that requires the Board’s resolution in order to decide Ground 1.

106. Ground 2 shows that the full scope of the genus “*4G communication standard*” is unsupported by the written description in the priority documents. This issue can also be decided under Fractus’s litigation arguments, so that there is no dispute over the meaning of the “*4G*” terms that requires the Board’s resolution to decide Ground 2.

107. Regardless, the relevant evidence on the meaning of the “*4G*” terms is explained below.

1. Intrinsic evidence

108. The written description never uses the term “*4G communication standard*.” The ’200 specification equates “4G standards” with “4G services” providing “4G features”:

A MFWD incorporating 3.5G or *4G features* (i.e., comprising 3G and other advanced services such as for instance HSDPA, WiBro, WiFi, WiMAX, UWB or other high-speed wireless standards, *hereinafter 4G services*) might require operation in additional frequency bands corresponding to *said 4G standards*[.]

EX1003, 25:15-20. The antecedent for “said 4G standards” (EX1003, 25:20) is “4G services,” and the “frequency bands corresponding to said 4G standards” comprise “frequency bands of the 4G services[.]” EX1003, 25:15-30. The patent defines a “4G antenna” as an “antenna covering one or more of the 4G services[.]” EX1003, 25:36-38.

109. Thus, a POSA would have understood that “*4G communication standard*” is met by a “wireless standard” for “4G services” and “*antenna... configured to... receive signals from a 4G communication standard*” is met by an antenna that is operable in a frequency range used by a “4G service,” where the “i.e.” signal means that the patent defines a “4G service” as “comprising 3G and other advanced services such as for instance HSDPA, WiBro, WiFi, WiMAX, UWB or other high-speed wireless standards[.]” EX1003, 25:15-20.

2. Fractus's Litigation Arguments

110. In the ADT Litigation, Fractus argued that “antenna functions” for “4G communication standard” meant antenna “compatibility with HSDPA, WiFi, WMax [sic], WiBro, UWB, or other highspeed wireless standards” further including “second-generation (2G) mobile, IMT-2000, [and] wireless local area network (WLAN)” (EX1017, 19-20) while “communication standard” meant “technical specifications relating to mobile or radio communication systems, including but not limited to GSM, UMTS, CDMA, W-CDMA, and LTE.” EX1017, 20 n.9; EX1018, 10 (¶36). Fractus also argued that “receive signals from a 4G communication standard” meant “the antenna could interact with a signal sent by a Fourth generation cellular technology to obtain or receive electromagnetic energy.” EX1017, 18 n.8 (cleaned up); EX1018, 10 (¶37).

111. In the Geotab Litigation, Fractus maps “antenna being configured to transmit and receive signals from a 4G communication standard” in [11.b] and “frequency bands being associated with a 4G communication standard” in claim 1 of the parent '677 patent to LTE bands 2, 4, 5, and 12. EX1024, 21 ('677 patent), 27 ('200 patent, excerpt below); see also [REDACTED]

[REDACTED]

[REDACTED]

[REDACTED].

[11d] The antenna system comprises a first antenna (indicated in red) configured to provide operation in at least LTE 700(B12)/1700-2100(B4)/1900(B2)

Regulatory Band:

❖ Cellular:

- LTE Band 2 : 1850 ~ 1910 MHz
- LTE Band 4 : 1710 ~ 1755 MHz
- LTE Band 5 : 824.0 ~ 849 MHz
- LTE Band 12 : 699 ~ 716 MHz

Source: FCC RF Exposure evaluation report

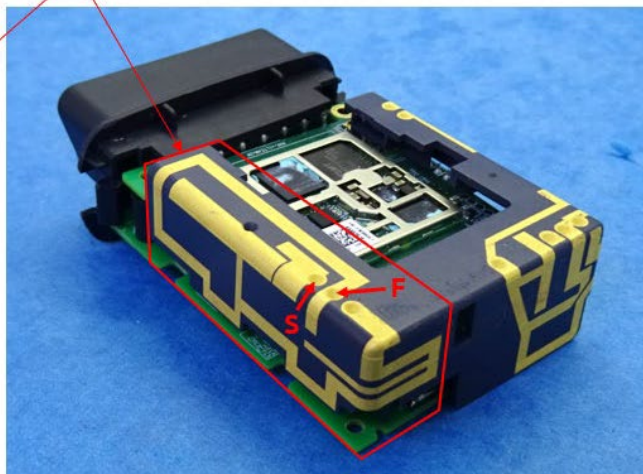

EX1024, 27.

112. Thus, Fractus takes the litigation position that “4G communication standard” is met by LTE.

113. LTE was “an evolution of 3G into an evolved radio access.” EX1039, 3, 21-25. LTE is a “fourth generation cellular technology” so that an antenna that can send/receive signals using LTE meets Fractus’s construction of “receive signals from a 4G communication standard” as “the antenna could interact with a signal sent by a Fourth generation cellular technology to obtain or receive electromagnetic energy.” EX1017, 18 n.8.

IX. GROUND 1: DOU+JING RENDERS OBVIOUS CLAIMS 1-15, 17, AND 19-20

A. Dou (EX1013)

114. Dou describes a wireless handheld device with an internal diversity antenna architecture for wireless devices such as, e.g., a handheld computer, mobile telephone, personal digital assistant (PDA), or pager. Dou, Abstract, [0015]. Dou describes locating a first antenna substantially near the top—and a second antenna located substantially near the bottom—of a device housing and/or internal PCB. Dou, Figs. 2A, 3A, [0017], [0032], [0040].

115. Antenna diversity refers to the use of multiple antennas within a communication system to improve signal reliability and quality. A diversity architecture such as that described in Dou can be implemented in various forms: spatial diversity (using physically separated antennas), pattern diversity (using antennas with different radiation patterns), and/or polarization diversity (using orthogonally polarized elements). These architectures can mitigate the effects of multipath fading, a phenomenon where signal reflections cause destructive interference at the receiver. By receiving multiple versions of the same signal through independent channels, a diversity architecture can select or combine the strongest signal, significantly improving reception quality, reducing bit error rate, and enhancing link robustness. Diversity is especially beneficial in mobile and indoor environments where signal conditions can change rapidly due to movement,

obstruction, or reflection. Indeed, I worked with diversity architectures in my first position at Motorola using automotive cellular radio.

116. Dou describes using antennas tuned for operating at multiple frequency ranges associated with several different services including, e.g., GSM, PCS, WCDMA/UMTS, GPS, NAMPS, “WiFi,” and Bluetooth. Dou, [0022]. The antennas “may be implemented using any type of suitable internal antenna” (Dou, [0028]) and can be of different types. Dou, [0034] (describing using a “monopole” along with any “other suitable antenna”). Dou’s wireless device can include “an additional antenna” of “any suitable type... disposed within the housing[.]” Dou, [0040].

B. Jing (EX1011)

117. Jing teaches a compact multiband “planar monopole antenna with a 2-dimensional structure” for mobile handsets that operates with DCS, PCS, UMTS, and WLAN services. Jing, 2657, 2660, Fig. 1(a) (below).²

² I use figures from Jing’s more legible online version (EX1014, Att. C-1), which is materially identical to EX1011.

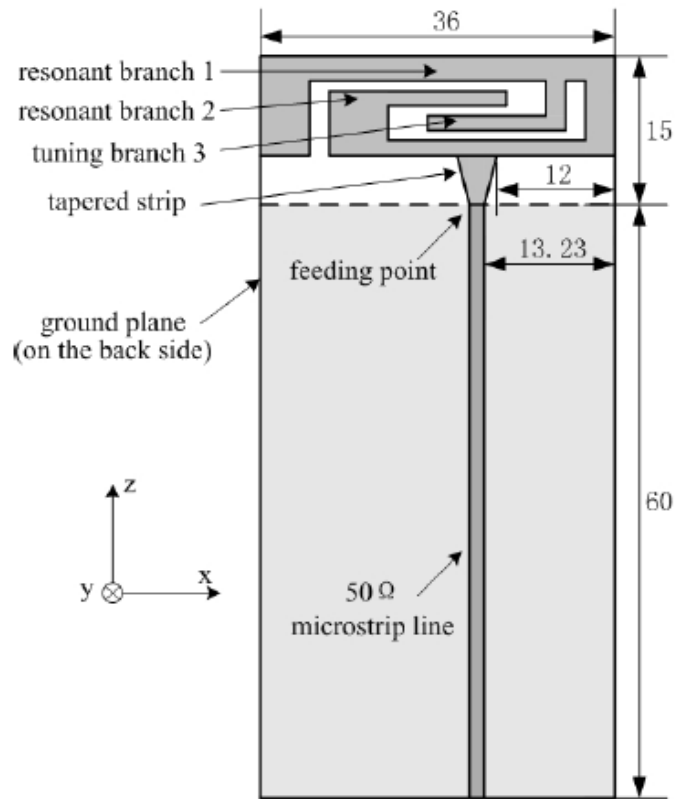

(a)

118. When matched to a suitable electronics (e.g., a transceiver) at VSWR (voltage standing wave ratio) of 2.5:1, Jing's antenna operates at 900-945 MHz, 1690-2250 MHz, and 2350-2800 MHz. Jing, Fig. 3 (measured return loss below), 2657-2658.

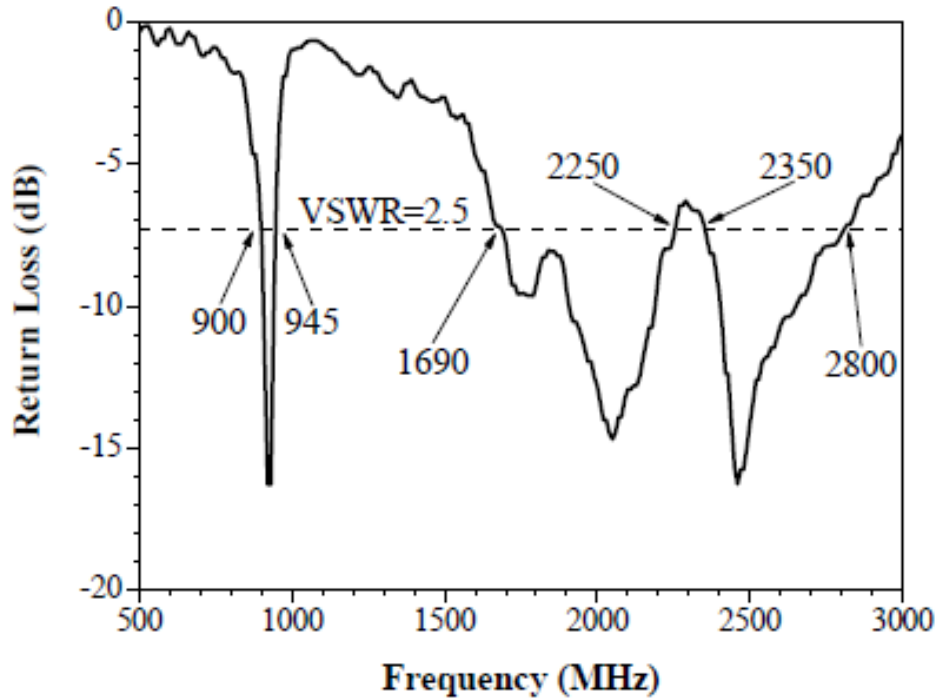

119. At better than (e.g., lower than) VSWR 2.5:1, the antenna covers frequencies used by several communication standards including Zigbee (902-928 MHz, EX1031, 70, Table 23), DCS (Digital Communication System, 1710-1880 MHz), PCS (Personal Communication Services, 1850-1990 MHz), UMTS (Universal Mobile Telecommunications System, 1920-2170 MHz), and WLAN (Wireless Local Area Network, 2400-2484 MHz). Jing, 2657.

120. VSWR, or Voltage Standing Wave Ratio, is used to evaluate how efficiently an antenna is impedance matched to the transmission line or system it is connected to—typically a coaxial cable and a radio transmitter or receiver. It is a dimensionless ratio that quantifies the amount of reflected power due to impedance mismatch between the antenna and the transmission line. When an RF signal is

transmitted down a cable to an antenna, maximum power transfer occurs when the antenna's impedance matches the transmission line's characteristic impedance, often 50 ohms. If there is an impedance mismatch, some of the signal is reflected back toward the source, creating a standing wave pattern along the line.

121. VSWR is defined as: $VSWR = (1 + |\Gamma|) / (1 - |\Gamma|)$, where Γ is the reflection coefficient at the feed point and $|\Gamma|$ ranges from 0 (perfect match) to 1 (total reflection). VSWR values range among: 1.0:1 = perfect match (no reflection); < 2:1 = considered good for most applications (*see* Ciais-Quadband, Fig. 3, 148-150); > 3.5:1 = significant mismatch, poor efficiency. For example, Jing's Fig. 3 provides evidence of a multiband antenna with VSWR = 2.5:1 (i.e., ~18% reflected power) defining the edges of its cited bands.

C. Dou+Jing

122. While Dou describes a wireless device having internally-mounted antennas, it does not describe particular antennas for achieving its wireless devices. Instead, Dou leaves the antenna selection to a POSA.

123. A POSA would have had reasons to use a Jing antenna for each of Dou's first and second antenna. Jing's antenna was designed for internal use in mobile handsets, making it suitable for use as Dou's "internal antenna" 306 and 308 "integrated with the wireless device." Dou, [0033], Figs. 3A-3B (below); Jing, 2657, Fig. 1(a) (below).

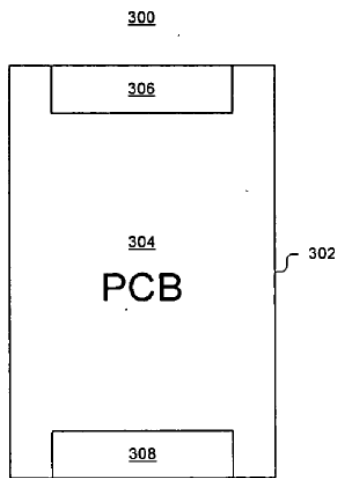

FIG. 3A

Dou

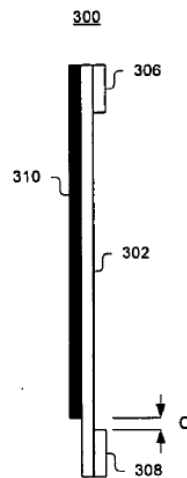
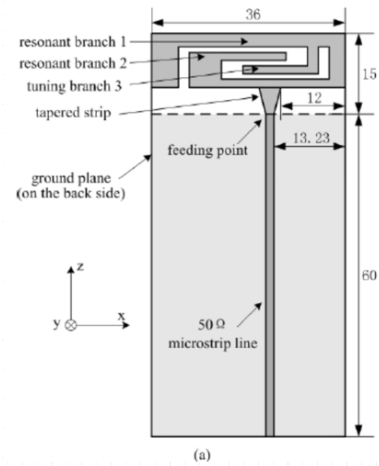

FIG. 3B

Jing



124. Jing’s antenna is a “planar monopole antenna” (Jing, 2657 (Abstract)), which Dou describes using for the first/second antennas. Dou, [0028], [0034].

Jing’s antenna provided operation at frequencies used by well-known communication standards (DCS, PCS, UMTS, Zigbee, WiFi) making it “suitable for mobile phone applications” like Dou’s wireless device. *Supra* §IX.B (Jing); Jing, 2658, Fig. 3; Dou, [0022] (describing exemplary coverage for GSM, PCS, “WCDMA/UMTS,” and “ISM band in 2.4 GHz range for WiFi and Bluetooth”).

125. WiFi is a certification that a system is compatible with WLAN communications. EX1003, 10:27 (WiFi uses IEEE Std. 802.11); EX1060, 1-2 (showing WiFi is a trademark of the Wi-Fi Alliance that certifies “interoperability of IEEE 802.11 products”).

126. In order to implement Duo using Jing's antenna, a POSA would have used a Jing antenna to implement each of Dou's antennas 306 and 308. Dou's PCB 302 optionally has ground plane 310 on the back, just like Jing has a "system ground plane" on the back surface of an FR4 substrate. Dou, Fig. 3B, [0034]; Jing, Fig. 1(a), 2658. POSAs would have recognized that whether the ground plane extends under Dou's antennas depends on the specifications required by the implemented antennas. Dou places antenna 308 at "no less than 5 mm" offset from ground plane 310 just like Jing places its antenna with a 5 mm taper offsetting it from its ground plane. Dou, Fig. 3B, [0034]; Jing, Fig. 1(a), 2657-2658.

127. A POSA would have implemented Dou's antenna 306 using Jing's antenna to achieve Dou's diversity architecture. Dou, [0034] (explaining embodiments not limited to depiction in Fig. 3).

128. As shown in modified Dou Fig. 3B (below), a POSA would have used Jing's teachings to modify Dou's ground plane 310 to replicate Jing's ground plane dimensions of $36 \times 60 \text{ mm}^2$, and limited the extent of Dou's ground plane 310 so that it did not extend behind Jing's antenna at 306, just like Dou does not extend it behind antenna 308. Jing, 2657-2658, Fig. 1(a); Dou, Figs. 3A-3B.

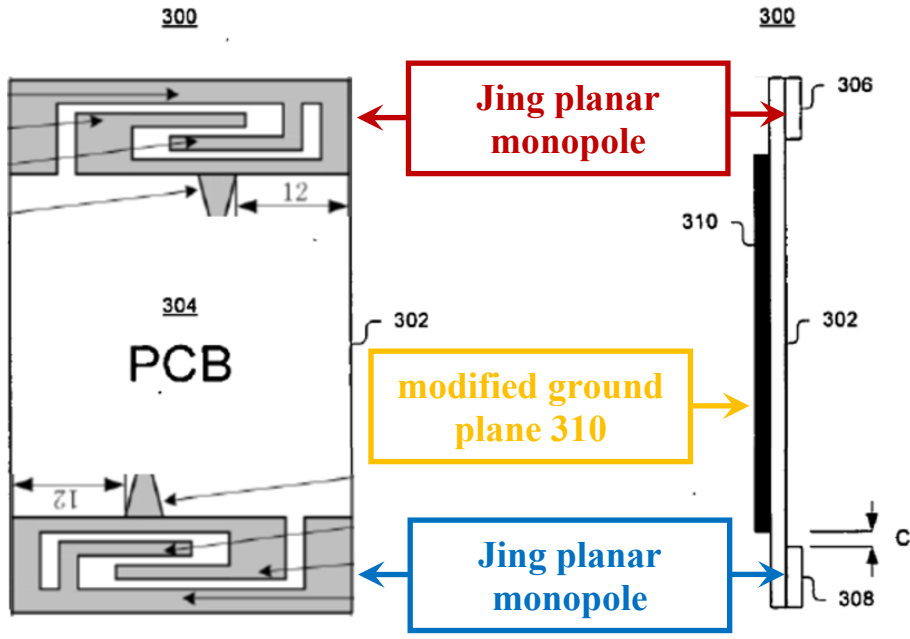

FIG. 3A

FIG. 3B

Dou implemented with Jing

129. Dou describes its wireless device having “three or more antennas... compris[ing] any suitable type of internal antenna” (Dou, [0040]), and describes the wireless device having separate antennas covering GPS (1575 MHz), WiFi (ISM 2.4 GHz), and Bluetooth (ISM 2.4 GHz). Dou, [0022].

130. As I explained above, WiFi is a certification that a system is interoperable with IEEE Std. 802.11 wireless local area networking (WLAN), and thus includes WLAN communications. EX1003, 10:27 (WiFi uses IEEE Std. 802.11). WiFi is a trademark of the Wi-Fi Alliance that certifies “interoperability of IEEE 802.11 products” and “promote[s] them as the global, wireless LAN standard across all market segments.” EX1060, 1-2. A POSA would have had

reasons to include a GPS antenna to provide the GPS wireless services that Dou describes, in frequency ranges (1575 MHz) not covered by Jing's antenna.

EX1048, 2 (GPS performance standard).

131. While Jing's antenna covers the 2.4 GHz ISM band at 2400-2500 MHz, it was conventional to include multiple antennas in a single mobile device to support dedicated communications using different services like WLAN and Bluetooth that used the same frequency range (e.g., the 2.4 GHz ISM band). For example, EX1029 describes a mobile device having *seven* antennas, including separate GPS antenna **64**, WLAN antenna **61**, and Bluetooth antenna **66**. EX1029, Fig. 9 (below), [0044]. Providing separate antennas for WLAN and Bluetooth—even if they used the same 2.4 GHz ISM band—simplified the electronics supporting those services and eliminated the need for switching or multiplexing access to a single antenna.

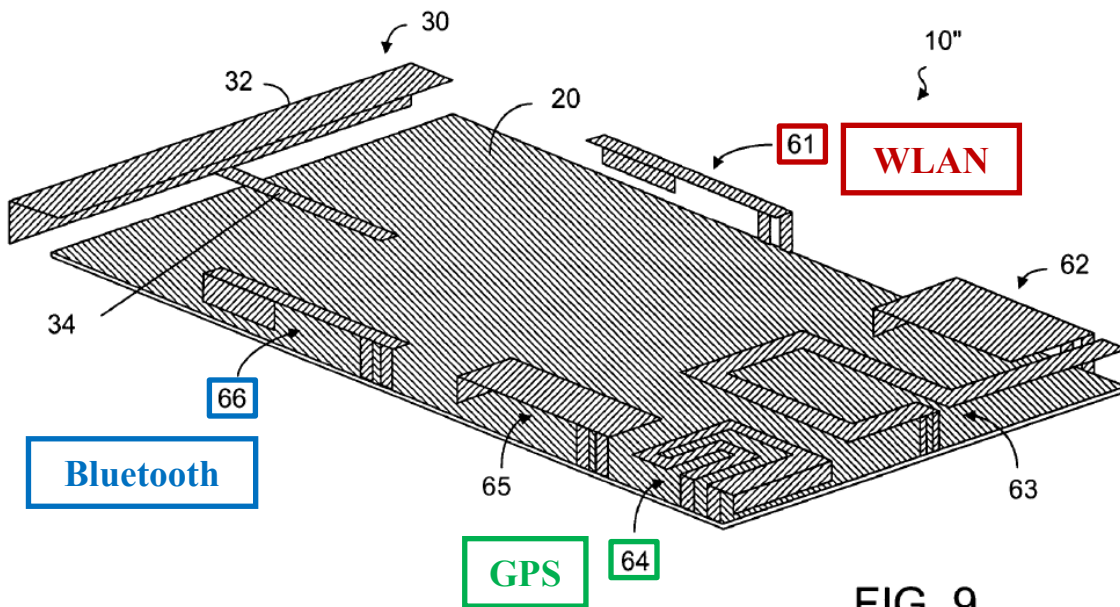

FIG. 9

132. Implementing Dou’s wireless device with Jing’s antenna providing Dou’s first antenna 306 and second antenna 308 (hereinafter “Dou+Jing”) would have combined familiar elements according to known methods with predictable results, and been no more than the “predictable use of prior art elements according to their established functions.” The same is true of adding a GPS and Bluetooth antenna to Dou’s device to provide additional services that Dou describes.

133. POSAs would have reasonably expected success using Jing’s antenna in Dou’s device because Jing designed its antenna for internal use in mobile handsets (Jing, 2657), and Dou expressly contemplates using multiband antennas—like Jing’s—as its first/second internal antenna (e.g., Dou, [0028]-[0029], [0034]). Dou describes antenna placement within the device according to “various performance and design constraints” known to POSAs. Dou, [0030].

Jing describes placing its antenna at the end of a PCB, just like Dou. Jing, Fig. 1(a), 2657; Dou, Figs. 3A-3B, [0031]-[0032]. It was well-within the POSA's ordinary skill to implement Dou's device with Jing's antenna, and the resulting antenna operation was predictable. Dou, [0012], [0063].

134. POSAs would have reasonably expected success including a GPS and a Bluetooth antenna in Dou's wireless device because this was conventional (EX1029, [0044]), Dou explains that "the antenna architecture may comprise three or more antennas" (Dou, [0040]), and Dou specifically describes the wireless device having GPS and Bluetooth coverage.

135. A POSA would have understood that a co-located dedicated Bluetooth antenna was compatible—and would not have interfered—with Jing's WLAN operation in the 2.4 GHz ISM band because—as EX1029 confirms—mobile devices conventionally used separate Bluetooth and WLAN antennas, and because the two services used different transmission techniques that minimized mutual interference. Bluetooth uses frequency hopping, which minimizes signal energy at a single frequency. EX1044, 27 ("A frequency hop transceiver is applied to combat interference and fading."), 69 (physical channel characterized by pseudo-random frequency hopping sequence), 75 (adaptive frequency hopping). A WLAN (e.g., IEEE Std. 802.11b) system senses whether a channel is busy (e.g., in use) before transmitting, which prevents interference from simultaneous transmission

on a channel (e.g., a discrete frequency range). EX1043, 58 (describing carrier sense and energy detection indicating a busy channel).

136. The combination (“Dou+Jing”) thus had at least *four* antennas: two Jing antennas, a GPS antenna, and a Bluetooth antenna, and renders obvious claims 1-15, 17, and 19-20 as shown below.

D. Claim 1

1. Preamble [1.PRE]

1.PRE	A wireless device comprising:
-------	-------------------------------

137. Dou+Jing meets [1.PRE] because Dou describes a wireless device comprising, *e.g.*, a handheld computer, mobile telephone, or PDA. Dou, [0015]-[0016], [0031], claim 1.

2. Limitation [1.a]

1.a	an antenna system comprising a ground plane and at least two antennas within the wireless device, the antenna system comprising:
-----	--

138. Dou+Jing meets “*an antenna system comprising... at least two antennas within the wireless device*” because Dou teaches that wireless device 300 has “an internal diversity antenna architecture comprising a first internal antenna 306 and a second internal antenna 308 disposed on the PCB 304....” Dou, Fig. 3B (annotated below), [0032].

139. Dou+Jing modifies Dou’s ground plane 310, which serves “to improve antenna performance in talk position and reduce SAR.” *Supra* §IX.C (combination), Dou, Fig. 3B (modified below), [0034].

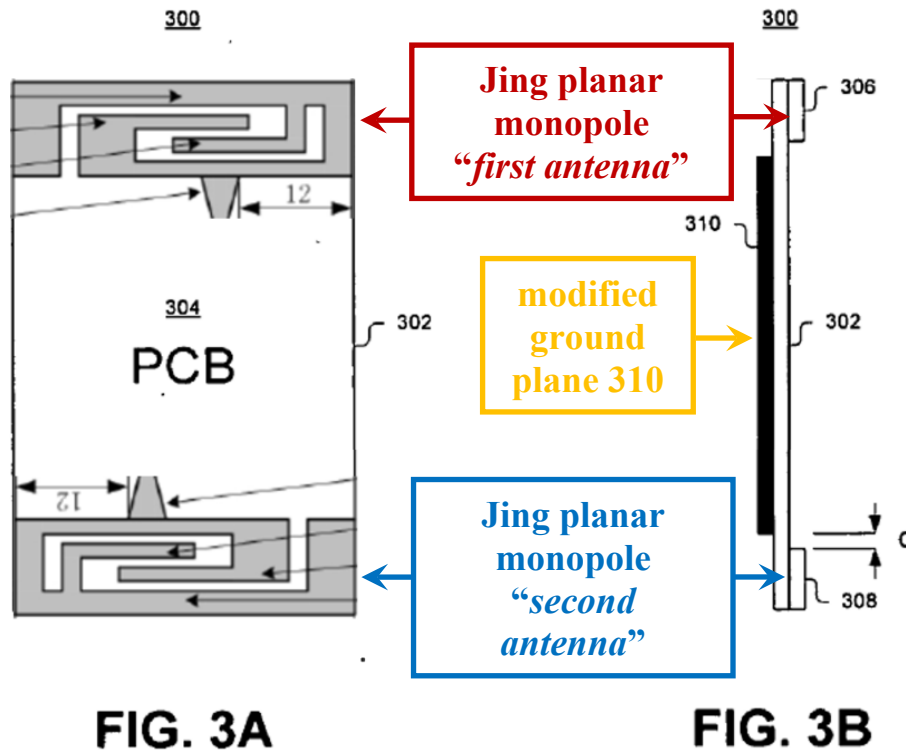

FIG. 3A

FIG. 3B

Dou+Jing

3. Limitation [1.b]

1.b	a first antenna proximate to a first short side of a ground plane rectangle enclosing the ground plane,
-----	---

140. Dou+Jing meets [1.b] because Dou’s antenna 306 (*first antenna*) is “located substantially at the top of... the PCB 304[.]” Dou, [0032]-[0033]. Dou describes ground plane 310 disposed on the back of PCB 304. Dou, Fig. 3B, [0032], [0034].

141. In Dou+Jing, ground plane 310 conforms to the dimensions of the ground plane in Jing, which is coterminous with the FR4 substrate (e.g., with dimensions 36 mm × 60 mm) but not extending beneath Jing’s antenna. Jing, 2657-2658, Fig. 1(a). Jing’s antenna “is printed on” a mobile device’s PCB substrate like Dou’s where ground plane 310 is “[o]n the back surface of the substrate.” Jing, Abstract, 2657-2658, Fig. 1(a); Dou, [0034], Fig. 3B. Jing places its antenna on the substrate’s top surface “*proximate*” to a 36 mm wide edge (*first short side*) of a rectangle enclosing the ground plane on the substrate’s opposite side. Jing, 2658, Fig. 1(a) (below); *supra* §IX.C (combination).

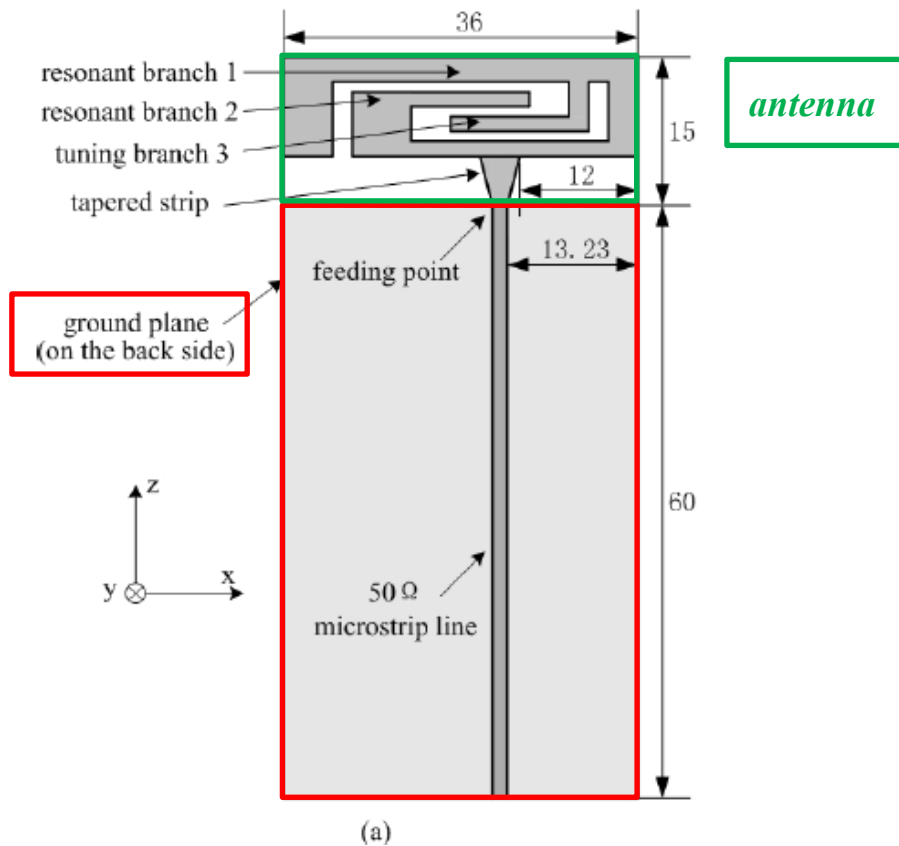

142. In Dou+Jing, modified ground plane 310 is bounded (e.g., *enclos[ed]*) by a 36 mm × 60 mm rectangle (*ground plane rectangle*) as Jing describes. Jing’s antenna implementing Dou’s antenna 306 is “*proximate to a first side*” of that *ground plane rectangle* because it extends from the 36 mm *first short side* of the rectangle enclosing the ground plane. Jing, 2657-2658, Fig. 1(a); Dou, Figs. 3A-3B (as modified below), [0032]-[0034] (antenna is “located substantially at the top of... the PCB 304,” but “the ground plane 310 does not extend underneath” it); *supra* §IX.C (combination).

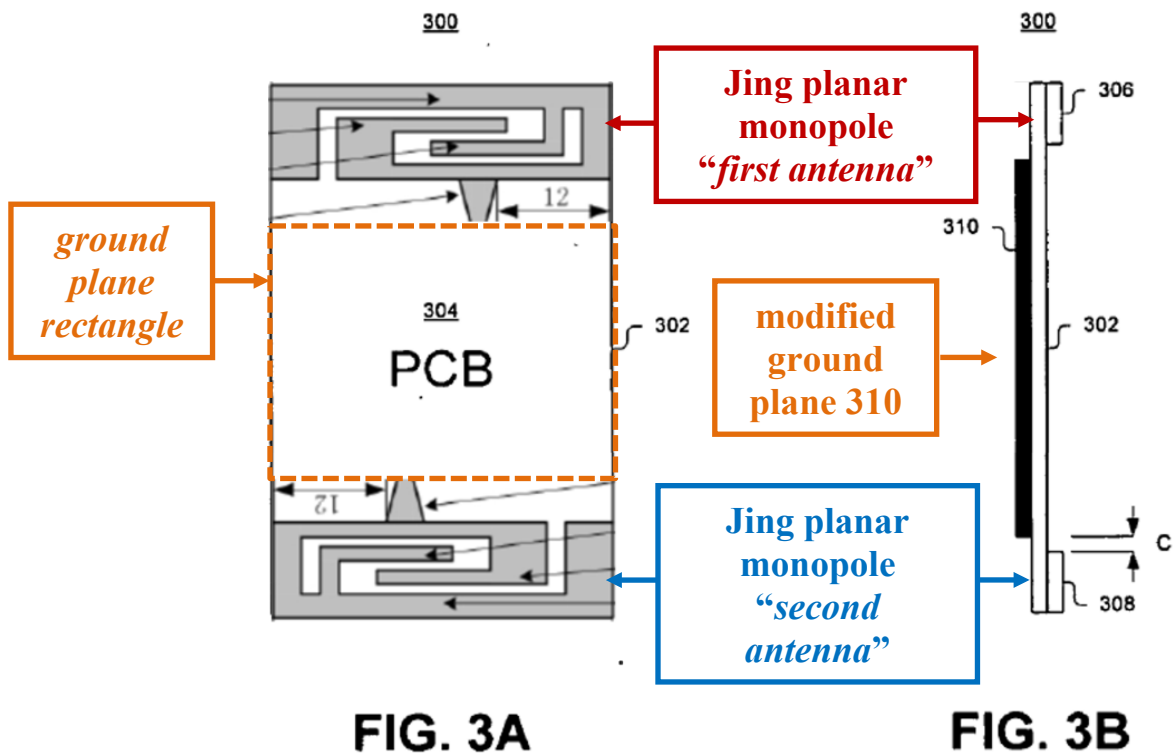

FIG. 3A

FIG. 3B

Dou+Jing

4. Limitation [1.c]

1.c	the first antenna being configured to support at least three frequency bands contained within first and second frequency ranges of the electromagnetic spectrum, the second frequency range being higher in frequency than the first frequency range,
-----	---

143. The plain meaning of “*at least three frequency bands contained within the first and second frequency ranges*” is that the first and second frequency ranges together contain within them “*at least three frequency bands.*” This is also how Fractus construes the same language in its litigation arguments on the parent ’677 patent. EX1024, 20-21.

144. Dou+Jing meets [1.c] because Jing’s antenna (*first antenna*) operates—within the “*electromagnetic spectrum*”—at **1690-2250 MHz** (*first frequency range*) and **2350-2800 MHz** (*second frequency range*), which is “*higher in frequency*” than 1690-2250 MHz. Jing, 2658, Fig. 3 (annotated below).

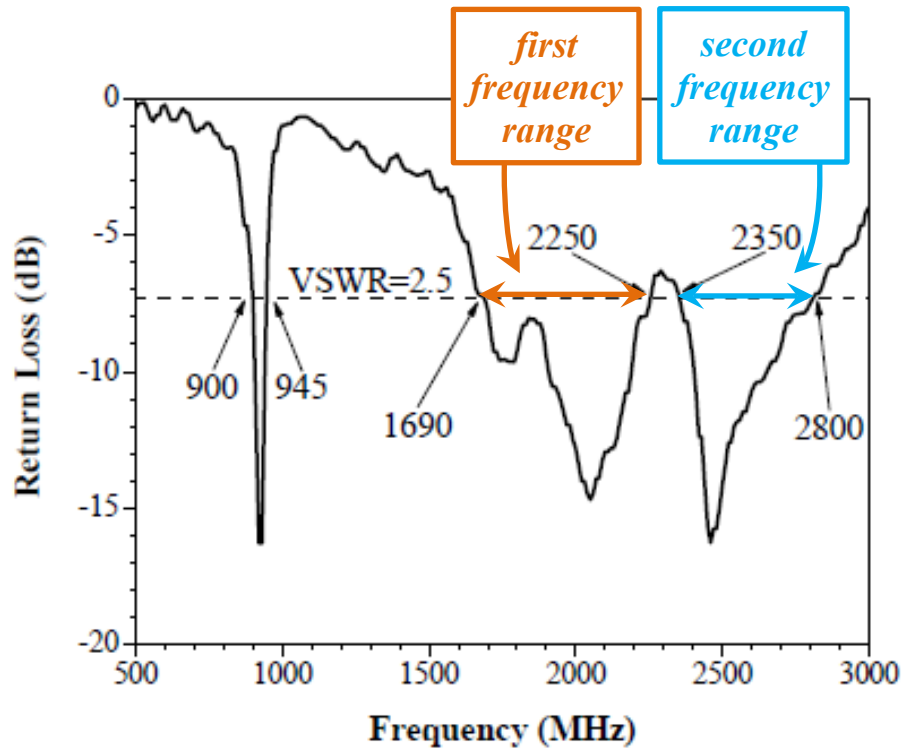

145. Although Jing describes its antenna as supporting frequency bands for DCS, PCS, UMTS, and WLAN (Jing, 2657), in fact the antenna is “*configured to support*” at least twenty-four (24) frequency bands “*contained within*” the frequency ranges it supports.

146. The **1690-2250 MHz** range contains at least **twenty-one** “*frequency bands*” shown in Table 1.

Table 1: Frequency bands within 1690-2250 MHz.

Band	Range (MHz)
DCS1800	1710-1880
PCS1900	1850-1990
UMTS Band I	1920-2170
UMTS Band II	1850-1990
UMTS Band III	1710-1880
UMTS Band IV	1710-2155
UMTS Band a	1900-1920, 2010-2025
UMTS Band b	1850-1910, 1930-1990
UMTS Band c	1910-1930
LTE Band 1	1920-2170
LTE Band 2	1850-1990
LTE Band 3	1710-1880
LTE Band 4	1710-2155
LTE Band 9	1749.9-1879.9
LTE Band 10	1710-2170
LTE Band 33	1900-1920
LTE Band 34	2010-2025
LTE Band 35	1850-1910
LTE Band 36	1930-1990
LTE Band 37	1910-1930
LTE Band 39	1880-1920

Jing, 2658 (DCS, PCS, UMTS); EX1030, 8-9 (DCS1800, PCS1900); EX1039, 139 (reference [100] identifies HSDPA specifications), 497-501, 599 (reference [100] is 3GPP TS 25.308 (EX1032)); EX1032 (UMTS HSDPA description); EX1035, 11-12 (UMTS standard comprises TS 25.101 (EX1033), 25.102 (EX1034), TS 25.308 (EX1032)); EX1033, 12-13 (Table 5.0 “UTRA FDD frequency bands”);

EX1034, 11 (UTRA/TDD frequency bands);³ EX1025, 13, Table 5.5-1 (“E-UTRA operating bands” defining LTE bands); EX1026, 11 (listing LTE FDD and TDD bands).

147. The **2350-2800 MHz** range contains at least **three** “frequency bands” shown in Table 2.

Table 2: Frequency bands within 2350-2800 MHz.

Band	Range (MHz)
ISM 2.4 GHz	2400-2500
LTE Band 7	2500-2690
LTE Band 38	2570-2620

Jing, 2658 (WLAN); EX1024, 27 (Fractus citing LTE bands); EX1025, 13, Table 5.5-1 (“E-UTRA operating bands” defining LTE bands); EX1026, 11 (listing LTE FDD and TDD bands); EX1031, 70 (listing ZigBee bands); EX1039, 497-501; EX1043, 1 (defining the 802.11 band); EX1044, 29 (defining Bluetooth band).

a. UMTS background

148. As background, UMTS (Universal Mobile Telecommunications System) was a 3G mobile communication standard standardized by 3GPP as the successor to GSM. It introduced WCDMA (Wideband Code Division Multiple

³ While Dou refers to “WCDMA/UMTS” in 1710-2170 MHz (Dou, [0022]), as shown in Table 2 the standard defines at least seven distinct “bands” within the 1710-2170 MHz frequency range.

Access) as the radio access technology and featured both circuit-switched and packet-switched domains. HSDPA (High-Speed Downlink Packet Access) is an enhancement to UMTS introduced in 3GPP Release 5, often referred to as 3.5G (although the '200 regards it as 4G). It improves downlink speeds through advanced scheduling, adaptive modulation and coding, and Hybrid ARQ mechanisms. HSDPA is fully integrated into the UMTS framework and uses the same Node B (base station) and frequency bands.

149. Like LTE that followed it, UMTS typically operated in paired FDD bands, where uplink and downlink transmissions occur in separate frequency ranges. For example, Band 1 uses 1920–1980 MHz for uplink and 2110–2170 MHz for downlink, with 190 MHz duplex spacing. EX1033, 12-13 (Table 5.0 “UTRA FDD frequency bands”). These paired bands allow simultaneous two-way communication using separate frequencies. Some UMTS deployments also use TDD (Time Division Duplexing), where uplink and downlink share the same frequency but are separated in time. EX1034, 11 (UTRA/TDD frequency bands).

b. LTE background

150. As background, 3GPP Release 8 (“LTE”) replaced older circuit-switched architectures with a flat, packet-based core network called the Evolved Packet Core (EPC). The radio access component, known as Evolved-UTRA (E-UTRA), introduced a new air interface using OFDMA in the downlink and SC-

FDMA in the uplink, offering improved spectral efficiency, higher throughput, and scalable bandwidths.

151. The LTE architecture includes E-UTRAN, composed of base stations (eNodeBs) that communicate directly with user equipment (UE). LTE does away with traditional circuit-switched voice, instead handling all services over IP. The 3GPP specifications define physical layer, RF requirements, and network interfaces across multiple documents (e.g., TS 36.101, 36.211). E-UTRA was designed as an evolution of UMTS, and even in 2006 it was widely understood by a POSA to be the basis for the upcoming 4G systems, despite the formal ITU definition of 4G arriving later. LTE typically uses Frequency Division Duplexing (FDD), which separates uplink and downlink transmissions into distinct frequency sub-bands. These bands are quoted with full frequency ranges for both uplink and downlink (e.g., Band 3: 1710–1785 MHz UL, 1805–1880 MHz DL) to ensure device compatibility, regulatory compliance, and efficient spectrum planning. EX1025, 13, Table 5.5-1 (“E-UTRA operating bands” defining LTE bands); EX1026, 11 (listing LTE FDD and TDD bands); EX1039, 497-502 (LTE bands).

152. Devices must support both sub-bands in hardware, and the duplex spacing impacts filter design, duplexers, and interference management. Some LTE bands use Time Division Duplexing (TDD), sharing a single frequency band across time-separated uplink and downlink slots.

153. Thus, Jing’s antenna meets [1.c] because it operates in (e.g., is operable to send and receive radiation in) at least twenty-one (21) bands in the *first frequency range* and at least three (3) bands in the *second frequency range*.

5. Limitation [1.d]

1.d	the first antenna being configured to transmit and receive signals from a 4G communication standard,
-----	--

154. Additional to the frequency bands discussed *supra* §IX.D.4 ([1.c]), Jing’s antenna also covers the 900-945 MHz frequency range encompassing the ISM 902-928 MHz frequency band. Jing, 2658, Fig. 3; EX1003, 10:24-34 (discussing ISM 902-928 MHz). Dou+Jing thus meets [1.d] several different ways.

155. *First*, the ’200 patent expressly defines HSDPA as a “4G feature” and “4G service” that it equates with a “4G standard.” EX1003, 25:14-20; *supra* §VIII.G (claim construction). HSDPA is part of the Universal Mobile Telecommunications System (UMTS) and supported by the UMTS frequency bands. EX1039, 139, 599 (EX1032 identifies HSDPA specification); EX1032 (UMTS HSDPA description); EX1035, 11-12 (UMTS standard comprises 3GPP TS 25.101 (EX1033), 25.102 (EX1034), 25.308 (EX1032)).

156. Jing's antenna supports at least seven (7) UMTS frequency bands, and such UMTS signals are each "*signals from a 4G communication standard*" at least because they support HSDPA. *Supra* §IX.D.4 ([1.c]), Table 2.

157. **Second**, the '200 patent expressly identifies "WiBro, WiFi, WiMAX, UWB or other high-speed wireless standards" as "4G services." EX1003, 25:14-18. The specification explains that WiFi encompasses IEEE Std. 802.11 WLAN. EX1003, 10:27. WLAN (e.g., WiFi) and Bluetooth use 2400-2484 MHz within the 2.4 GHz ISM band (2400-2500 MHz), which as explained above Jing's antenna covers. EX1043, 1 (defining the 802.11 standard using 2.4 GHz ISM band); EX1044, 29 (defining Bluetooth standard using 2.4 GHz ISM band). Jing's antenna is capable of transmitting and receiving WLAN and Bluetooth signals, which are each separately "*signals from a 4G communication standard*."

158. **Third**, as the '200 patent recognizes, Zigbee is a "high-speed wireless standard" for wireless networking like WiFi, Bluetooth, and UWB. EX1031, 17-18 (Zigbee uses IEEE Std. 802.15.4 wireless networking layers, provides wireless peer-to-peer communication in mesh networks), 31; EX1003, 10:24-34, 25:14-18. Zigbee is thus a "*4G communication standard*" because it is a "wireless standard" for "4G services" (*supra* §VIII.G). Zigbee uses the ISM bands at 902-928 MHz and 2400-2500 MHz. EX1031, 17 (IEEE 802.15.4-2003, PHY layers at 915 MHz and 2400 MHz), 18, Fig. 1 (same), 70 (Table 23). Jing's antenna is capable of

transmitting and receiving Zigbee signals, which are “signals from a 4G communication standard.” *Supra* §IX.D.4 ([1.c]), Table 1.

159. **Fourth**, as explained *supra* §VIII.G, Fractus argues in litigation that an antenna that can send/receive signals using LTE meets Fractus’s construction of “receive signals from a 4G communication standard” as “the antenna could interact with a signal sent by a Fourth generation cellular technology to obtain or receive electromagnetic energy.” EX1017, 18 n.8. Fractus also argues in litigation that [11.b] “antenna configured to provide operation in at least three frequency bands being used by 4G communication standards” is met by LTE bands. *E.g.*, EX1024, 27 (excerpt below); EX1039, 497-502 (describing LTE frequency bands); *see also* [REDACTED]

[REDACTED]

[REDACTED]

[11d] The antenna system comprises a first antenna (indicated in red) configured to provide operation in at least LTE 700(B12)/1700-2100(B4)/1900(B2)

- Regulatory Band:
- Cellular:
 - LTE Band 2 : 1850 ~ 1910 MHz
 - LTE Band 4 : 1710 ~ 1755 MHz
 - LTE Band 5 : 824.0 ~ 849 MHz
 - LTE Band 12 : 699 ~ 716 MHz

Source: FCC RF Exposure evaluation report

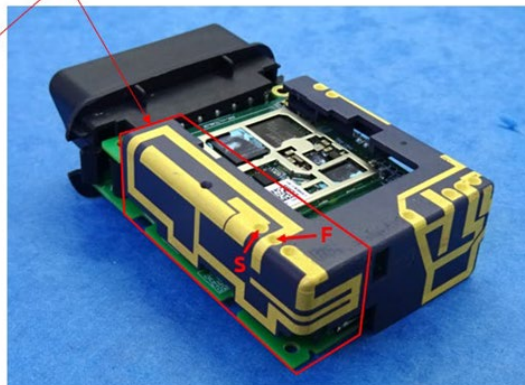

EX1024, 27.

160. Jing’s antenna is capable of transmitting and receiving signals in fourteen (14) LTE bands that are each “*signals from a 4G communication standard*” under Fractus’s litigation arguments. *Supra* §§VIII.G.2, IX.D.4 ([1.c]), Tables 1, 2.

6. Limitation [1.e]

1.e	the first antenna defining a first antenna contour comprising an entire perimeter of the first antenna, and
-----	---

161. Jing’s antenna “*defin[es] a first antenna contour comprising an entire perimeter of the first antenna*” (blue outline in the figure below) just like the perimeter of antenna contour 350 in the ’200 patent’s embodiments in Figure 3 or antenna system 1200 in Figure 12A (below right), meeting [1.e]. EX1003, 7:62-64, 33:65-34:7; *see also* EX1024, 28 (Fractus applying “*antenna contour*”); ; *supra* §§VIII.A (perimeter), VIII.D (antenna contour); Jing, 2658 (“The planar monopole occupies an area of 36x15 mm².”).

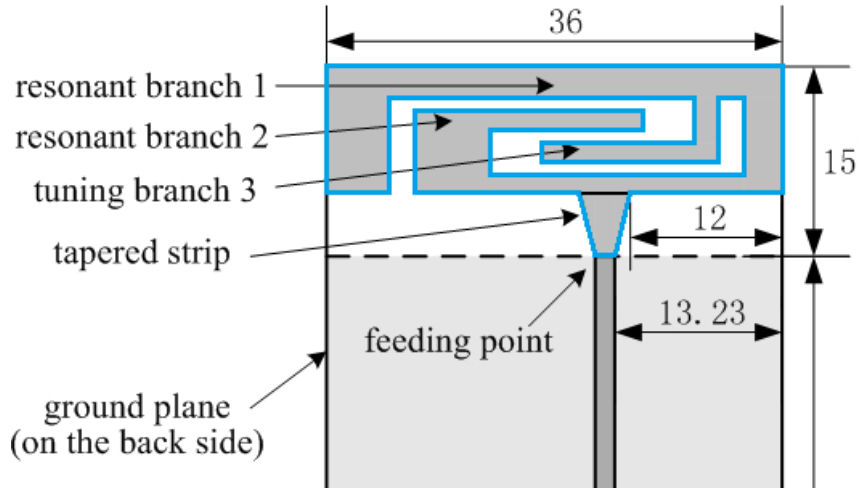

Jing, Fig. 1(a) (in part, annotated)

162. As I explained *supra* §VIII.D, the '200 patent expressly defines an “antenna contour” as “a set of joined and/or disjointed segments” including “the perimeter of one or more antenna elements placed in the antenna rectangle.”

EX1003, 15:16-37. Jing’s antenna rectangle is the 36 mm by 15 mm rectangle above the ground plane shown above in Jing’s Figure 1(a).

163. The contour of Jing’s antenna rectangle is shown below with slant-fill marking the conductive elements bounded by the contour as in the '200 patent (e.g., Figs. 12A, 13A).

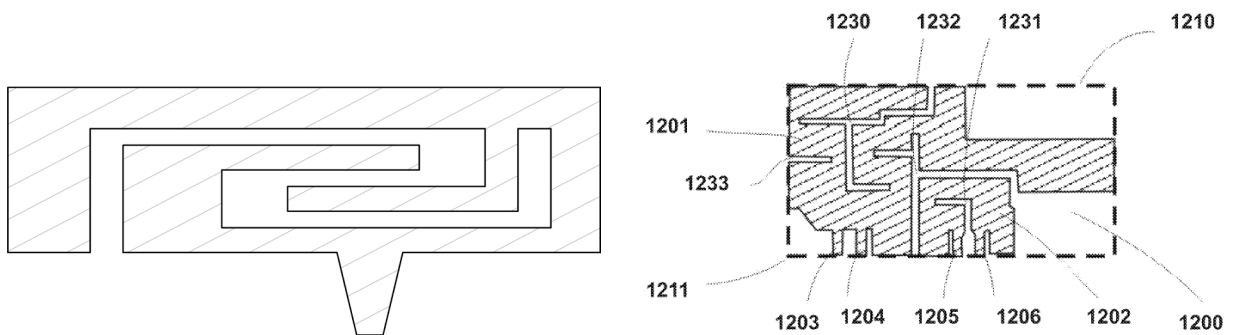

Jing’s antenna contour

FIG. 12A
'200 patent

164. This properly scaled rendering of Jing’s “antenna contour” was generated using the dimensions provided in Jing’s Fig. 1(b) (below), the dimensions that Jing provides for the tapered strip (“a tapered strip of 5-mm length” and “the width of the strip changes linearly from 1.54 mm at the feeding point to 4 mm at the edge of the patch”), and the location of the tapered strip specified in Figure 1(a). Jing, 2657-2658.

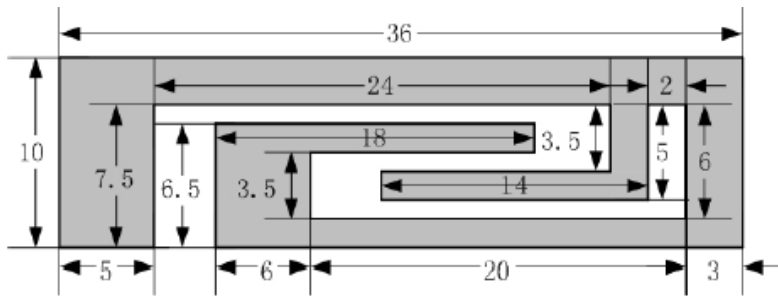

(b)
Jing, Fig. 1(b)

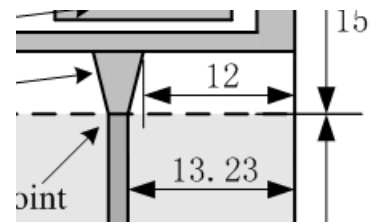

Jing, Fig. 1(a) (in part)

165. A combination of Jing’s teachings in its figures and text yields a properly scaled version showing the full measurements of each portion below:

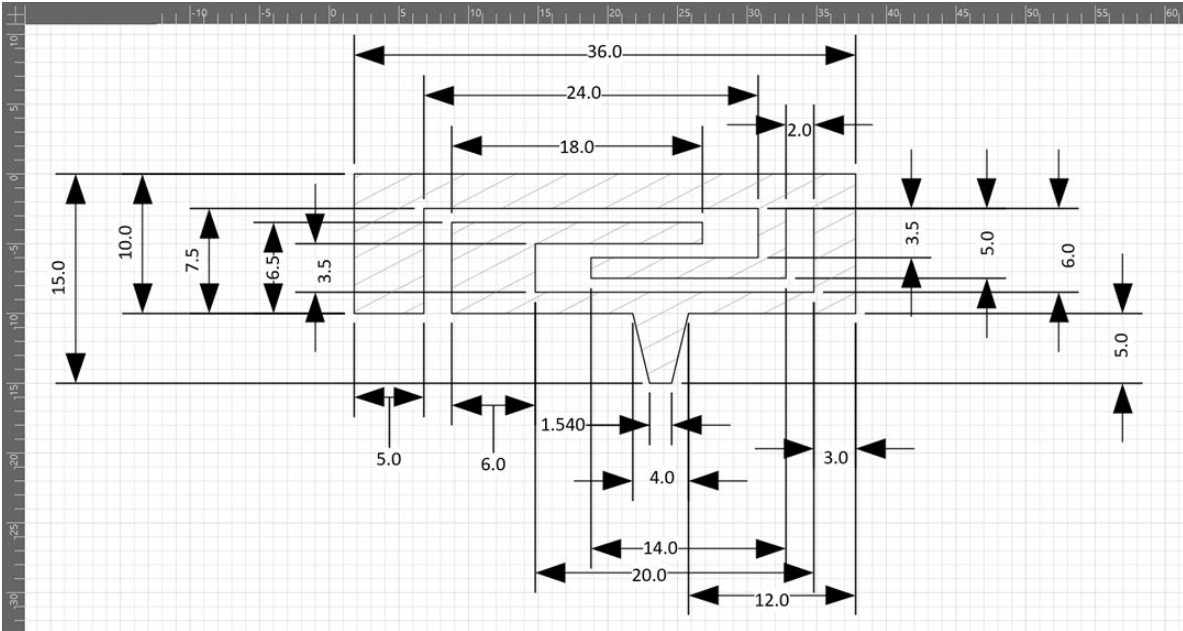

7. Limitation [1.f]

1.f	wherein the first antenna contour has a level of complexity defined by complexity factor F21 having a value of at least 1.20 and complexity factor F32 having a value of at least 1.35; and
-----	---

166. Dou+Jing meets [1.f] because Jing’s antenna contour (“*first antenna contour*”) has *complexity factor* $F_{21} = 1.43$ (“*at least 1.20*”) and $F_{32} = 1.70$ (“*at least 1.35*”).

a. Calculating F_{21}

i. Grid G_2

167. The ’200 patent identifies a preferred embodiment wherein second grid G_2 has nine columns. EX1003, 17:49-51. With a 36 mm × 15 mm *antenna rectangle* (Jing, Fig. 1(a)) **nine columns** yields a cell width $\left(\frac{36\text{ mm}}{9}\right) = 4.0\text{ mm}$.

168. Setting an odd number of “ $2n+1$ ” rows with integer n such that $0 < n < 5$ yields these results, where aspect ratio is the ratio of cell width to cell height (EX1003, 17:28-32, 18:8-10):

# rows	cell height (mm)	aspect ratio
3	$\left(\frac{15 \text{ mm}}{3}\right) = 5.0$	$\left(\frac{4.0}{5.0}\right) = 0.80$
5	$\left(\frac{15 \text{ mm}}{5}\right) = 3.0$	$\left(\frac{4.0}{3.0}\right) = 1.33$

Therefore, three rows provides grid cells “as square as possible,” e.g., an aspect ratio closest to one. *Supra* §VIII.E.1.a (claim construction); EX1003, 17:5-8, 17:28-18:3. Thus, grid G2 with nine (9) columns and three (3) rows has cells “as square as possible[.]”

ii. $N_2 = 27$.

169. The 3 x 9 grid G_2 (blue outline) is superimposed over the Jing’s *antenna contour* below. The ’200 patent states that “in the present invention the boundary of the cell is also part of the cell.” EX1003, 19:13-20. Therefore, all twenty-seven (27) cells in G_2 are included in N_2 because all cells have a boundary that coincides with the *antenna contour*. Thus, all cells “include at least a point of the antenna contour”. EX1003, 19:12-20.; *supra* §VIII.E.2.a.

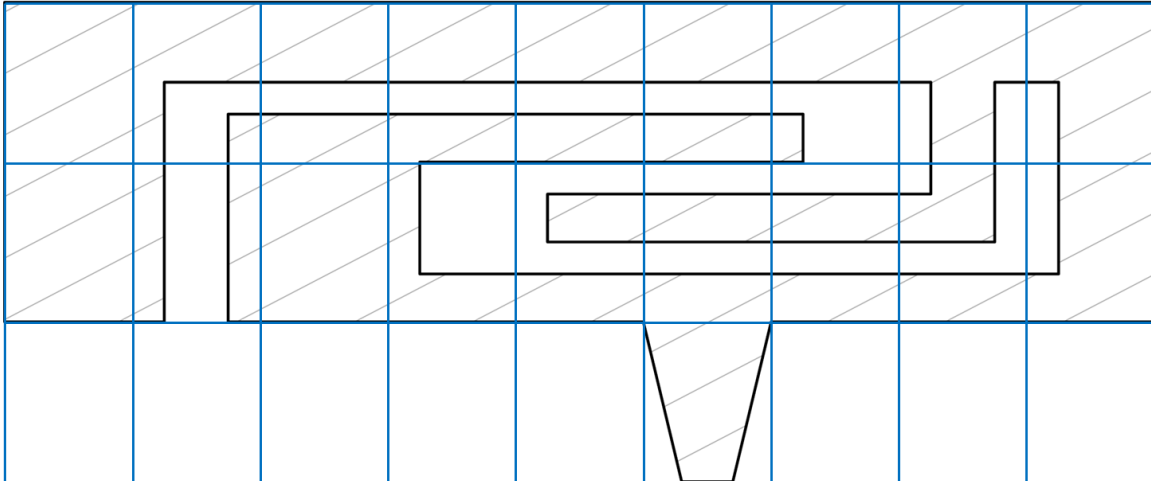

170. In case it is not immediately obvious, I further explain why certain cells “include at least a point of the antenna contour,” based on the below annotated figure. *Supra* §VIII.E.2.a; EX1003, 19:12-20.

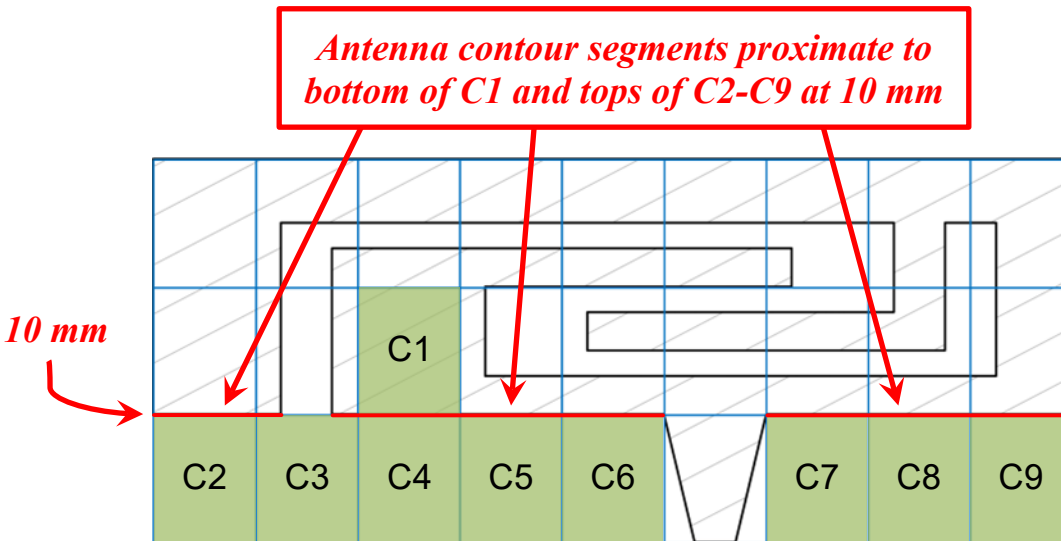

As I determined above, each cell height is 5.0 mm. *Supra* §IX.D.7.a.i. The bottom edge of Jing’s antenna segments above the tapered strip (marked above in red) are at 10 mm (5.0 mm \times 2). Jing, 2657, Figs. 1(a), 1(b). Thus, the bottom edge of cell C1 (at 10 mm) and the top edges of cells C2-C9 (also at 10 mm) match the bottom

edge of the antenna segments above tapered strip, and thus “include at least a point of the antenna contour.”

iii. Grid G_1

171. Jing’s antenna feed is closest to the bottom right corner (“feed point corner”) of the *antenna rectangle*, so as discussed *supra* §VIII.E.1.b grid G_1 is placed from the bottom right corner below. Jing, Fig. 1(a) (below showing “feeding point”); *supra* §VIII.E.1.b; EX1003, 18:24-19:2.

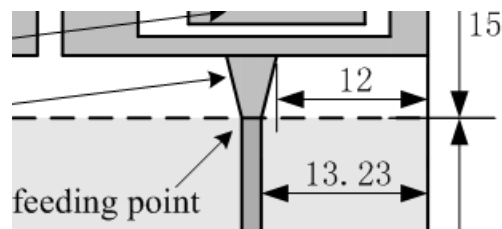

Grouping four G_2 cells (blue grid lines) into a single G_1 cell results in the 2 x 5 grid G_1 shown below (orange grid lines). EX1003, 18:66-19:11.

outline). *Supra* §VIII.E.1.c; EX1003, 19:62-20:4. The G_3 cells have width

$$\left(\frac{36mm}{18}\right) = 2.0 \text{ mm and height } \left(\frac{15mm}{6}\right) = 2.5 \text{ mm.}$$

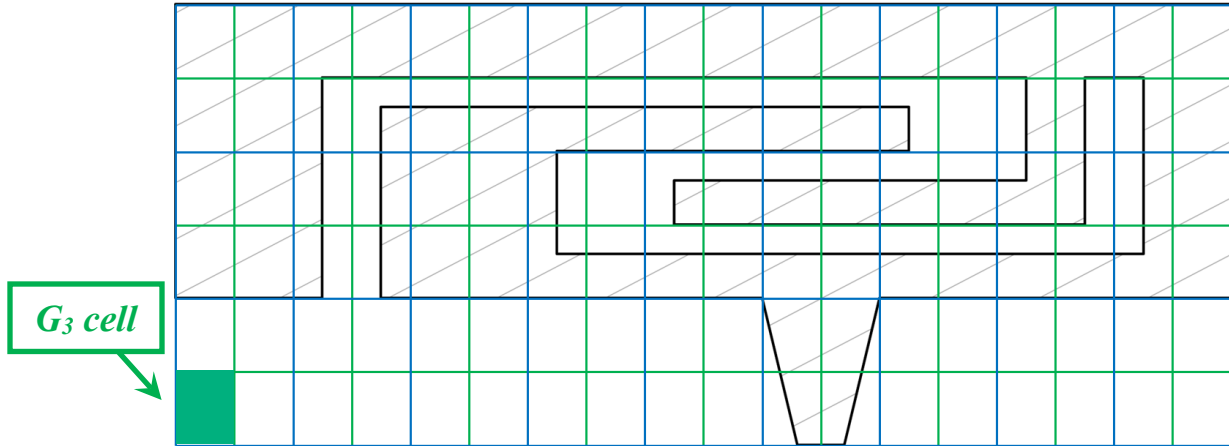

ii. $N_3 = 88$.

175. As shown below 20 numbered G_3 cells do *not* “include at least a point of the antenna contour.” *Supra* §VIII.E.2.b; EX1003, 20:1-11. Thus, the G_3 cell count $N_3 = (108 - 20) = 88$.

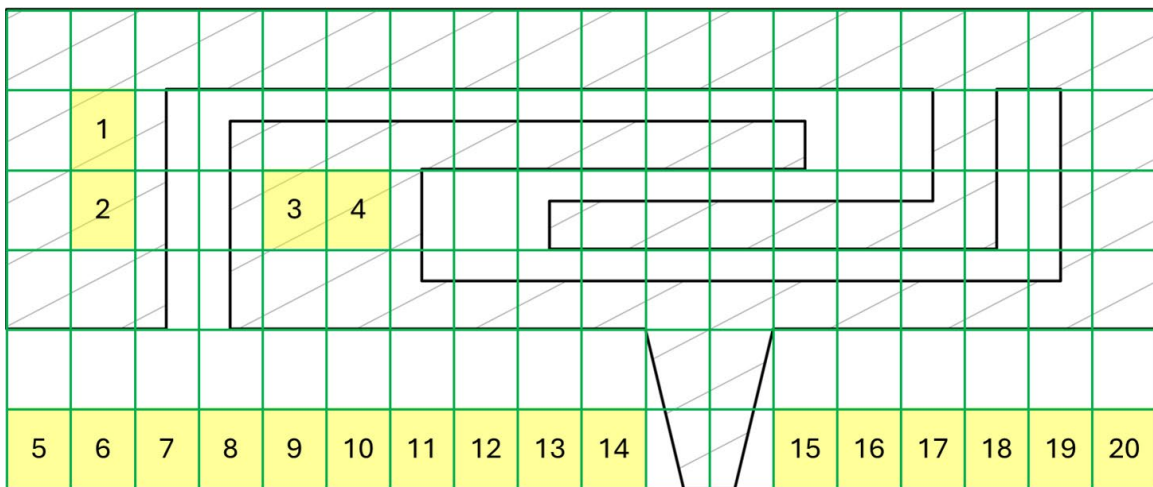

176. Among the cells that I shaded yellow above, cells 1-4 are completely within Jing’s antenna contour, cells 5-20 are completely outside the antenna

contour. Thus, cells 1-20 do not “include at least a point of the antenna contour.”

Supra §VIII.E.2.b; EX1001, 19:61-20:11.

177. In case it is not immediately obvious, I further explain why certain cells “include at least a point of the antenna contour,” based on the below annotated figure. *Supra* §VIII.E.2.a; EX1003, 20:5-11.

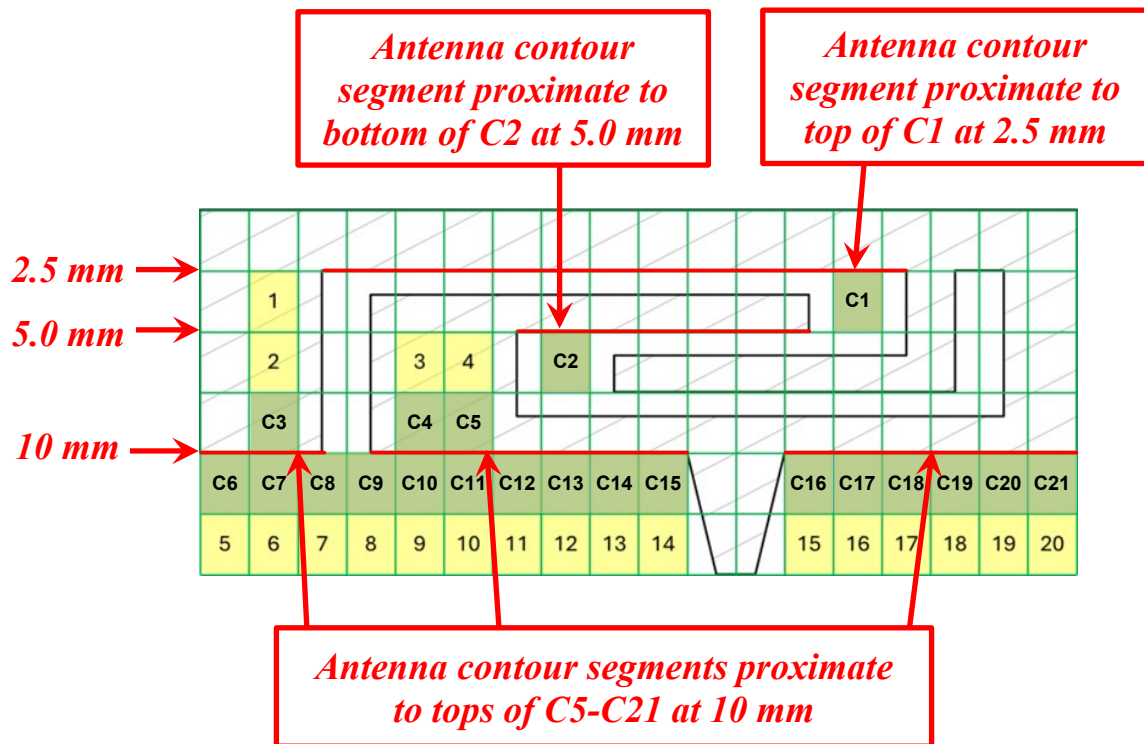

As I determined above, each cell height is 2.5 mm. *Supra* §IX.D.7.b.i. The bottom edge of Jing’s antenna segment marked in red above C1 is at 2.5 mm. Jing, 2657, Figs. 1(a), 1(b). The top edge of Jing’s antenna segment marked in red above C2 is at 5.0 mm (2.5 mm × 2). Jing, 2657, Figs. 1(a), 1(b). The bottom edge of Jing’s antenna segments above C6-C21 marked in red are at 10 mm (2.5 mm × 4). Jing,

2657, Figs. 1(a), 1(b). Thus, an edge of C1-C21 align with an edge of an antenna segment, and thus “include at least a point of the antenna contour.”

iii. Calculation $F_{32} = 1.70$.

178. The *complexity factor* F_{32} for Jing’s *antenna contour* is thus:

$$F_{32} = -\left(\frac{\log(N_3) - \log(N_2)}{\log(1/2)}\right) = -\left(\frac{\log(88) - \log(27)}{(-1)\log(2)}\right)$$

$$= \left(\frac{\log(88/27)}{\log(2)}\right) = \left(\frac{0.513}{0.301}\right) = 1.70.$$

Supra §VIII.E.2.b; EX1003, 20:5-17.

8. Limitation [1.g]

1.g	a second antenna proximate to a first long side of the ground plane rectangle,
-----	--

179. Dou+Jing meets [1.g] because it implements Dou antenna 308 as a Jing antenna (*second antenna*). *Supra* §IX.C (combination). Jing’s antenna is 36 mm wide and extends at each end to the two long edges of PCB 302, as shown below (modified Dou Figs. 3A-3B). Each long edge of PCB 302 coincides with a “*long side of the ground plane rectangle*” that encloses modified ground plane 310 shown below. *Supra* §§IX.C (combination), IX.D.2 ([1.a]).

180. Since Jing’s antenna and ground plane are both 36 mm wide, and positioned next to the ground plane rectangle, using two Jing antennas in Dou’s device locates both antennas “*proximate to*” a short side (36 mm edge) and a “*long*

side” (60 mm edge) of “the ground plane rectangle” (orange outline). *Supra* §IX.C (combination).

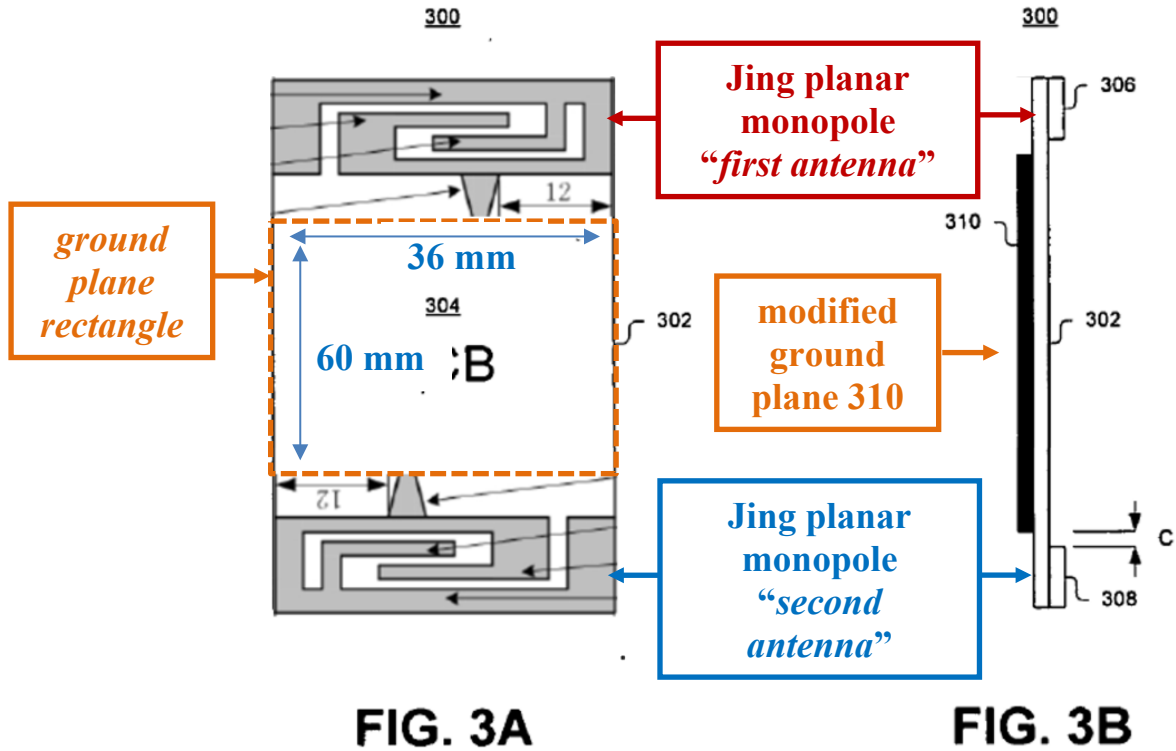

FIG. 3A

FIG. 3B

Dou+Jing

9. Limitation [1.h]

1.h	and wherein the second antenna is configured to receive signals from a 4G communication standard.
-----	---

181. Dou+Jing meets [1.h] because Jing’s antenna (*second antenna, supra* §IX.D.8 ([1.g])) “*is configured to receive signals from a 4G communication standard*” in the same way Jing’s antenna (*first antenna*) does for [1.d] *supra* §IX.D.5.

E. Claim 2

2	[Claim 1's device], wherein the second antenna defines an antenna box that is a minimum-sized parallelepiped that completely encloses a volume of the second antenna and wherein each face of the minimum-sized parallelepiped is tangent to at least one point of the volume of the second antenna, an orthogonal projection of the antenna box along a normal to a face with a largest area of the second antenna defining an antenna rectangle, an aspect ratio of the antenna rectangle being defined as a ratio between a width and a height of the antenna rectangle, and wherein the aspect ratio has a value of at least 2.
---	---

182. Dou+Jing's device comprises Jing's antenna (*second antenna*). *Supra* §§IX.D.8 ([1.g]), IX.C (combination).

183. Jing's antenna is a "planar monopole antenna with a 2-dimensional structure" having an area of "36×15 mm²." Jing, 2657-2658. The claim defines "an antenna box" of Jing's antenna as "a minimum-sized parallelepiped that completely encloses a volume of the first antenna and wherein each face of the minimum-sized parallelepiped is tangent to at least one point of the volume" is the antenna's rectangular area of 36×15 mm². *Supra* §VIII.B (*antenna box*). Thus, "an orthogonal projection of the antenna box along a normal to a face with a largest area of the first antenna defining an antenna rectangle" is a rectangle enclosing a 36×15 mm² area encompassing Jing's antenna. Jing, Fig. 1(a) (detail below).

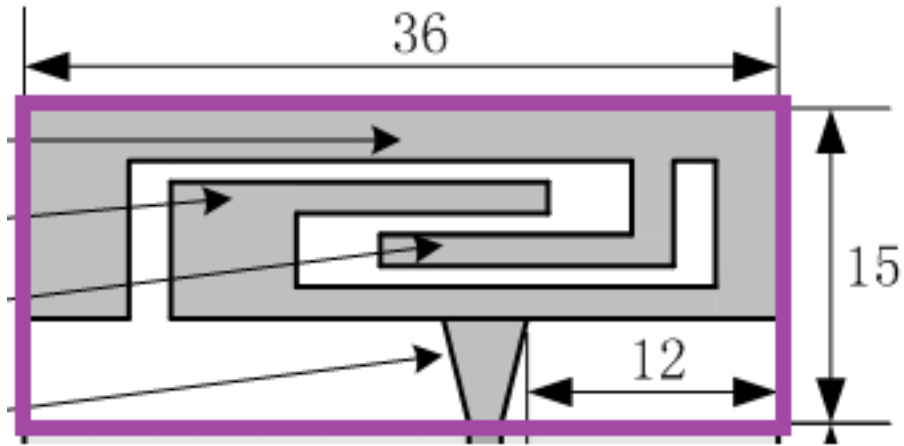

184. The “aspect ratio” of Jing’s “antenna rectangle being defined as a ratio between a width and a height of the antenna rectangle” is $\left(\frac{36}{15}\right) = 2.4 > 2$.

F. Claim 3

[3]	[Claim 2's device], wherein the second antenna defines a second antenna contour comprising an entire perimeter of the second antenna, wherein a length of the second antenna contour is greater than four times a diagonal of the antenna rectangle.
-----	--

185. For the same reasons discussed *supra* §IX.D.6 ([1.e]) for the *first antenna*, Dou's antenna 308 implementing a second Jing antenna "*defines a second antenna contour comprising an entire perimeter of the second antenna.*"

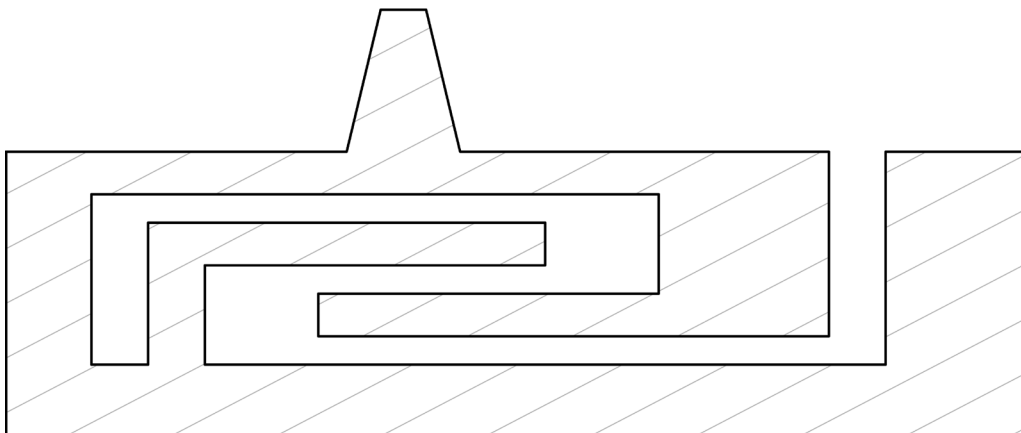

Jing's antenna contour (located as Dou's antenna 308)

186. The *length* of the *entire perimeter* of Jing's antenna contour is defined by Figures 1(a) and 1(b) (below) and Jing's description stating that the 5 mm-high tapered portion is "4 mm at the edge of the patch" and "1.54 mm at the feeding point." Jing, 2657-2658. Figs. 1(a), 1(b).

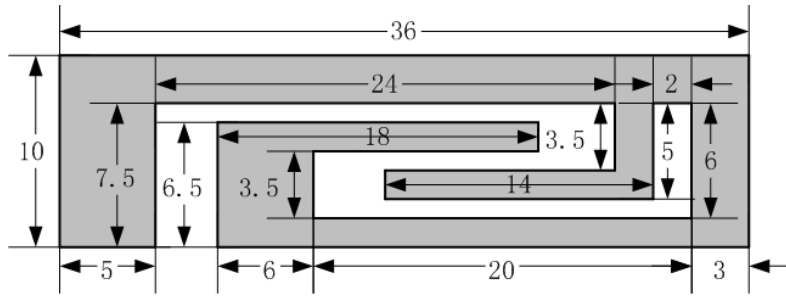

Jing, Fig. 1(b)

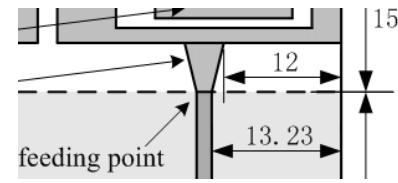

Jing, Fig. 1(a) (in part)

187. Each segment of Jing's *antenna contour* is labeled in the figure below for clarity:

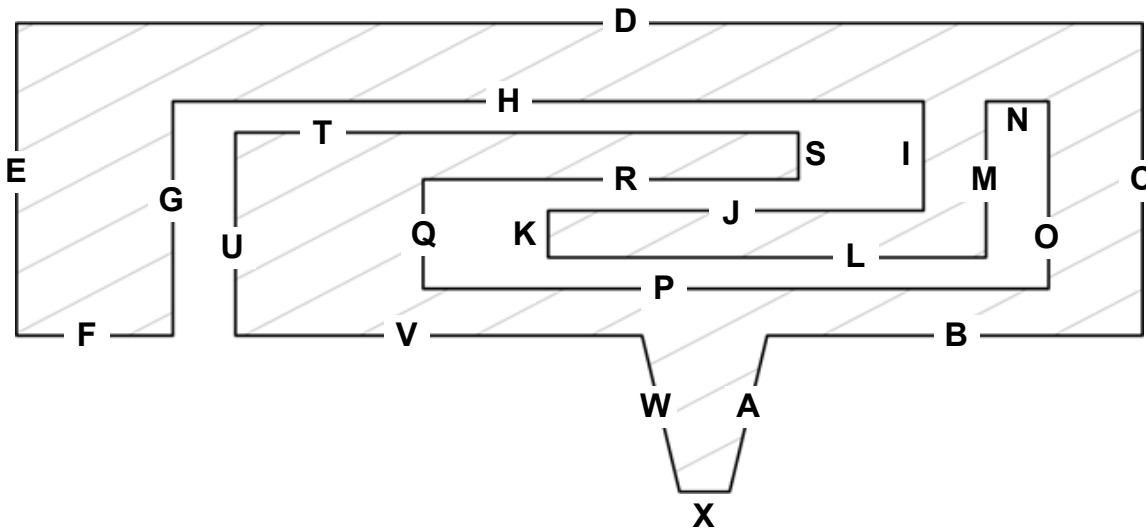

188. The length of segment **V** (13 mm) is determined by subtracting the length of segment **B** (12 mm) (Jing, Fig. 1(a)) and the length where the tapered strip meets the patch (4 mm) (Jing, 2658) from the entire length of the segment that meets the tapered strip (29 mm) (Jing, Fig. 1(b)) (i.e., $V = 13 = 29 - 12 - 4$).

189. The length of segment **X** is specified by Jing as 1.54 mm. Jing, 2658. The lengths of segments **A** and **W** are determined using the length of segment **X** (1.54 mm), the 4 mm length where the tapered strip meets the patch (Jing, 2658),

and the height of the tapered strip (5 mm) (Jing, 2658) by calculating the hypotenuse (**A** and **W**) of the right triangles indicated in green in the figure below, where the top of the triangle (**Z**) is half of the difference between the top of the tapered strip (4 mm) and the bottom of tapered strip (1.54 mm):

$$Z = 1.23 \text{ mm} = \frac{4.0 \text{ mm} - 1.54 \text{ mm}}{2}$$

$$A = W = \sqrt{(5.0 \text{ mm})^2 + (1.23 \text{ mm})^2}$$

$$A = W = 5.15 \text{ mm} = \sqrt{26.51 \text{ mm}^2}$$

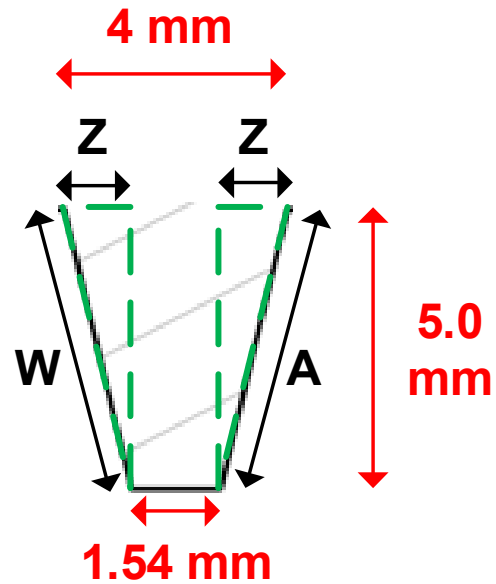

The lengths of segments C-U are provided by Jing's Figure 1(b).

190. The following table provides the lengths (in mm) of segments A-X:

Segment	Length	Segment	Length	Segment	Length
A	5.15	I	3.5	Q	3.5
B	12	J	12	R	12
C	10	K	1.5	S	1.5
D	36	L	14	T	18
E	10	M	5	U	6.5
F	5	N	2	V	13
G	7.5	O	6	W	5.15
H	24	P	20	X	1.54
Total	109.65	Total	64	Total	61.19

Thus, “*a length of the second antenna contour*” for Jing’s antenna is **234.84 mm** (109.65 mm + 64 mm + 61.19 mm).

191. Jing’s *antenna rectangle* is 36 mm by 15 mm which defines “*a diagonal of the antenna rectangle*” of 39 mm as follows:

$$39 \text{ mm} = \sqrt{(36 \text{ mm})^2 + (15 \text{ mm})^2}$$

192. Dou+Jing meets claim 3 because “*a length of the second antenna contour*” (i.e., 234.84 mm) “*is greater than four times a diagonal of the antenna rectangle*” (i.e., $4 \times 39 \text{ mm} = 156 \text{ mm}$).

G. Claims 4, 5

4	[Claim 1's device], wherein the first antenna is configured to support at least four frequency bands.
5	[Claim 1's device], wherein the first antenna is configured to support at least five frequency bands.

193. Dou+Jing meets claims 4 and 5 for the same reasons discussed *supra* §§IX.D.4 ([1.c]), IX.D.5 ([1.d]), since Jing's antenna (*first antenna*) is *configured to support* twenty-four (24) frequency bands.

H. Claim 6

1. Preamble [6.PRE]-[6.a], [6.d]-[6.e], [6.g]

194. Dou+Jing meets Elements [6.PRE]-[6.a], [6.d]-[6.e], and [6.g] for the reasons it meets the corresponding limitations below. EX1028, 1-3.

Element	Corresponding Limitation	Discussion <i>supra</i>
[6.PRE]	[1.PRE]	§IX.D.1
[6.a]	[1.a]	§IX.D.2
[6.d]	[1.e]	§IX.D.6
[6.e]	[1.f]	§IX.D.7
[6.g]	Claim 2	§IX.E

195. Dou+Jing meets the remaining limitations of claim 6 as follows.

2. Limitation [6.b]

6.b	a first antenna configured to provide operation in at least four frequency bands being used by 4G communication standards,
-----	--

196. Dou+Jing meets [6.b] because, as discussed *supra* §IX.D.5 ([1.d]), Dou’s antenna 306 (*first antenna*) implemented using Jing supports at least seven UMTS frequency bands supporting HSDPA, two ZigBee bands (ISM 902-928 and ISM 2400), and fourteen LTE bands, each “*being used by 4G communication standards.*” Jing’s antenna therefore *provides operation in at least twenty-three “frequency bands being used by 4G communication standards.”*

3. Limitation [6.c]

6.c	wherein at least two of the at least four frequency bands are contained within a first frequency range and at least two of the four frequency bands are contained within a second frequency range, the first frequency range being lower in frequency than the second frequency range,
-----	--

197. The antecedent for “four frequency bands” is [6.b]. As discussed *supra* §§IX.D.4-IX.D.5 ([1.c]-[1.d]), Jing’s antenna supports *a first frequency range* at 1690-2250 MHz and *a second frequency range* at 2350-2800 MHz, wherein the “*first frequency range*” (1690-2250 MHz) is “*lower in frequency than the second frequency range*” (2350-2800 MHz). *Supra* §§IX.D.4 ([1.c]); Jing, 2658, Fig. 3.

198. The “*first frequency range*” (1690-2250 MHz) supports twenty-one frequency bands of which the nineteen (19) UMTS and LTE bands are “*used by 4G communication standards*” meeting [6.n], while the “*second frequency range*” (2350-2800 MHz) supports at least three frequency bands, each of which (ISM 2.4 GHz, LTE band 7, and LTE band 38) is “*used by 4G communication standards.*” *Supra* §§IX.D.4 ([1.c]), IX.D.5 ([1.d]), IX.H.2 ([6.b]).

4. Limitation [6.f]

6.f	a second antenna configured to operate in at least one frequency band being used by a 4G communication standard,
-----	--

199. Dou+Jing meets [6.f] because, as discussed *supra* §§IX.D.8 ([1.g]), IX.H.2 ([6.b]), IX.H.3 ([6.c]), Dou’s *second antenna* 308 implementing Jing operates in at least ten “*frequency band[s] being used by a 4G communication standard.*”

5. Limitation [6.h]

6.h	and wherein at least one of the first and second antennas is close to a first short side of a ground plane rectangle enclosing the ground plane.
-----	--

200. Dou+Jing meets [6.h] for the reasons discussed *supra* §§IX.D.3 ([1.b]), IX.D.8 ([1.g]) because Dou+Jing’s antennas 306, 308 are both located “*close to*” the top and bottom, respectively, of “*a first short side of a ground plane rectangle enclosing the ground plane.*”

I. Claim 7

7	[Claim 6's device], wherein the first antenna contour comprises at least 20 segments.
---	---

201. As discussed *supra* §§IX.D.6 ([1.e]), Jing's antenna implemented as Dou's antenna 306 (*first antenna*) has an antenna contour shown below, which comprises 24 (*at least 20*) segments. Jing, Fig. 1(a)-(b).

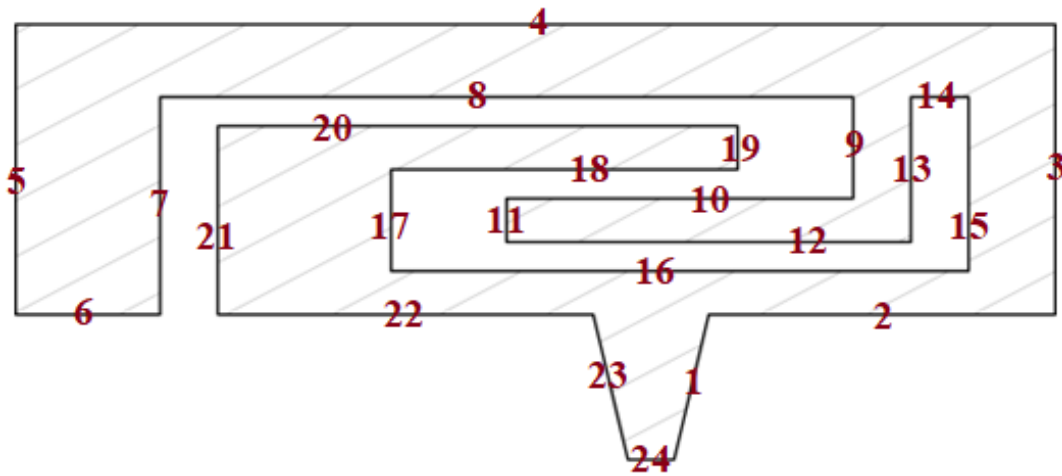

J. Claim 8

8	[Claim 6's device], wherein at least one of the first and second antennas is close to a first long side of the ground plane rectangle.
---	---

202. Dou+Jing meets claim 8 for each *first* and *second* Jing antenna for the reasons discussed *supra* §IX.D.8 ([1.g]).

K. Claim 9

9	[Claim 6’s device], wherein the second antenna defines a second antenna contour comprising an entire perimeter of the second antenna, wherein a length of the second antenna contour is greater than four times a diagonal of the antenna rectangle.
---	--

203. Dou+Jing meets claim 9 for the reasons it meets claim 3. *Supra* §IX.F (claim 3).

L. Claim 10

10	[Claim 6’s device], wherein the antenna system comprises a third antenna configured to provide operation in a wireless communication standard.
----	--

204. Dou+Jing meets claim 10 because it includes a dedicated Bluetooth antenna (*third antenna*). *Supra* §IX.C (combination). The Bluetooth antenna is “*configured to provide operation in a wireless communication standard,*” e.g., Bluetooth. EX1044 (Bluetooth specification).

M. Claim 11

1. Limitations [11.PRE]-[11.f], and [11.h]

205. Dou+Jing meets Elements [11.PRE]-[11.f], and [11.h] for the reasons it meets the corresponding limitations below. EX1028, 4-8.

Element	Corresponding Limitation	Discussion <i>supra</i>
[11.PRE]	[1.PRE]	§IX.D.1
[11.a]	[1.a]	§IX.D.2
[11.b]	[6.b]	§IX.H.2

Element	Corresponding Limitation	Discussion <i>supra</i>
[11.c]	[1.e]	§IX.D.6
[11.d]	Claim 7	§IX.I
[11.e]	[1.f]	§IX.D.7
[11.h]	[1.g], [6.h]	§§IX.D.8, IX.H.5

206. Dou+Jing meets [11.f], wherein Jing’s antenna is the *first antenna*, for the reasons it meets claim 2 (wherein Jing’s antenna is the “*second antenna*”), *supra* §IX.E. Dou+Jing meets the remaining limitations of claim 11 as follows.

2. Limitation [11.g]

11.g	a second antenna configured to provide operation in a first wireless service,
------	---

207. Dou+Jing meets [11.g] for the same reasons discussed *supra* §IX.D.8 ([1.g]) wherein Jing’s antenna is the *second antenna* implementing Dou’s antenna

308. As discussed *supra* §IX.D.4 ([1.c]), Jing’s antenna operates in the 2350-2800 MHz frequency range that supports the ISM 2.4 GHz band. Jing, 2658, Fig. 3.

The ISM 2.4 GHz band is used by the WiFi standard, the ZigBee standard, and the Bluetooth standard, which are each a *wireless service*, meeting [11.g]. EX1003, 10:24-34 (defining “WiFi (IEEE802.11 standards), Bluetooth, [and] ZigBee” as “wireless connectivity” services); EX1031, 70 (listing ZigBee bands); EX1039, 497-501; EX1043, 1 (defining the IEEE802.11b band); EX1044, 29 (defining Bluetooth band).

N. Claim 12

12	[Claim 11's device], wherein the first antenna is configured to support at least four frequency bands.
----	--

208. Dou+Jing meets claims 12 for same reasons it meets claim 4. *Supra* §IX.G; EX1028, 7.

O. Claim 13

13	[Claim 11's device], wherein the first wireless service is a WiFi communication standard.
----	---

209. Dou+Jing meets claim 13 for the reasons it meets [11.g] *supra* §IX.M.2 because Jing's antenna provides operation at 2400-2484 MHz in the ISM 2.4 GHz band for the IEEE 802.11b standard (*first wireless service*), which is “*a WiFi communication standard.*” EX1003, 10:24-34; EX1043, 11, 49-50.

P. Claim 14

14	[Claim 13's device], wherein the first wireless service provides operation in the 2400-2480 MHz frequency range and the 5.1-5.9 GHz frequency range.
----	--

210. Dou+Jing meets claim 14 for the reasons it meets [11.g] and [13] *supra* §IX.M.2, IX.O because WiFi uses IEEE Std. 802.11 wireless networking (*first wireless service*), and IEEE Std. 802.11 includes IEEE Std. 802.11b *operating in* the “2400-2480 MHz frequency range” (EX1043, 11 (defining 802.11b)) and IEEE Std. 802.11a *operating in* “the 5.15–5.25, 5.25–5.35 and

5.725–5.825 GHz unlicensed national information infrastructure (U-NII) bands” (EX1042, 3 (defining 802.11a)). EX1003, 10:24-34 (defining “WiFi (IEEE802.11 standards)”).

Q. Claim 15, 17

15	[Claim 11’s device], wherein the antenna system comprises a third antenna.
17	[Claim 15’s device], wherein the third antenna is configured to provide operation in a second wireless service.

211. Dou+Jing meets claims 15 and 17 because it includes a GPS antenna (*third antenna*), and the GPS antenna is *configured to provide operation* with GPS, which is a *wireless service*. EX1003, 10:46-49 (describing “a geolocation service” as an example *wireless service*); EX1048, 2 (describing GPS as “a positioning and timing service” operating “through the band 1563.42 to 1587.42 MHz”); *supra* §IX.C (combination); Dou, [0022], [0040], [0045]; *see also*

[REDACTED]

[REDACTED]

[REDACTED].

R. Claims 19, 20

19	[Claim 15's device], wherein the antenna system comprises a fourth antenna.
20	[Claim 19's device], wherein the fourth antenna is configured to provide operation in a third wireless service.

212. Dou+Jing meets claims 19 and 20 because its device includes four antennas: two Jing antennas (*first and second antenna, supra* §IX.D.2 ([1.a]), IX.M.1 ([11.b]), IX.M.2 ([11.g]), a GPS antenna (*third antenna, supra* §IX.Q (claim 15)), and a dedicated Bluetooth antenna (*fourth antenna configured to provide operation in a third wireless service*). *Supra* §IX.C (combination); Dou, [0040] (“may comprise *three or more antennas*” including “any suitable type of internal antenna disposed within the housing of a wireless device”); EX1044 (Bluetooth specification).

X. GROUND 2: BALIARDA-543 ANTICIPATES AND/OR RENDERS OBVIOUS CLAIMS 1-20

A. Claims 1-20 Are Not Entitled To Priority Before April 7, 2014.

213. I was asked to form an opinion whether a POSA reading the description with the four corners of U.S. Patent Application No. 11/614,429 (“the ’429 application”) on **December 21, 2006** would have concluded that the description reasonably conveyed that the applicants possessed the idea of an

antenna operating at frequency ranges associated with the frequency bands of LTE including LTE bands 12, 13, and 14 between 698 and 806 MHz.

214. In my opinion, a POSA would not have concluded that the applicants “had possession of the claimed subject matter” in Challenged Claims 1-20 on December 21, 2006, because on that date the LTE standard had not been completed and none of the LTE frequency bands had been defined. As a result, on December 21, 2006 nobody—not the applicants, not a POSA—could have determined whether a wireless device had an antenna that covered or sent or received signals associated with the LTE standard, as later claimed.

215. The ’429 application published January 24, 2008 as EX1040, U.S. Patent Pub. No. 2008/018543 (“Baliarda-543”). For simplicity, in the analysis below I refer to Baliarda-543 when evaluating the ’429 application’s written description.

216. The claims require antennas that are capable of transmitting/receiving signals for 4G communication as specified in “4G communication standards” as follows. These are, collectively, the “4G limitations” or “4G terms.”

- **Claims 1-5:** an antenna—having particular complexity factors (e.g., [1.f])—that is “*configured to transmit and receive signals from a 4G communication standard*”:

1.d	the first <i>antenna</i> being <i>configured to transmit and receive signals from a 4G communication standard</i>
1.h	and wherein the second <i>antenna</i> is <i>configured to receive signals from a 4G communication standard</i>

- **Claims 6-10:** an antenna—having particular complexity factors (e.g., [6.e]) and aspect ratio (e.g., [6.g])—that is “*configured to provide operation in [a] frequency band[] being used by 4G communication standards*”:

6.b	a first <i>antenna configured to provide operation in at least four frequency bands being used by 4G communication standards</i>
6.f	a second <i>antenna configured to operate in at least one frequency band being used by a 4G communication standard</i>

- **Claims 11-20:** a *first* antenna—having particular complexity factors (e.g., [11.e]) and aspect ratio (e.g., [11.f])— that is “*configured to provide operation in... frequency bands being used by a 4G communication standard*”:

11.b	a first <i>antenna configured to provide operation in at least three frequency bands being used by 4G communication standards</i>
------	---

217. As Fractus alleges in litigation, and explained above, LTE is a “wireless standard” for “4G services,” meeting “*4G communication standard.*” *Supra* §VIII.G.2. Thus, an LTE band is a “*frequency band being used by a 4G communication standard.*” *Supra* §VIII.G.2.

218. The '429 application has no written description showing that the applicants on December 21, 2006 possessed the idea of a device having antennas meeting these 4G limitations wherein the 4G communication standard is LTE, or an antenna—having claimed complexity factors or aspect ratio—supporting LTE communications at any then-undefined LTE band, let alone LTE bands within the 698 to 806 MHz spectrum allocated to television.

219. The '429 application has no written description of LTE frequency bands or the 3GPP Technical Specification 36.101 V8.4.0 (2008-12)—published years *after* the '429 application's filing—that defines LTE and its frequency bands. Baliarda-543; EX1025, EX1026, 7 (LTE specification completed in March 2009); EX1039, 497-502.

220. In December 2006, there were discussions ongoing about 4G but what a 4G communication system would look like was undefined. Only years later did ITU's IMT-Advanced in Report ITU-R M.2134, adopted November 2008, define the requirements for a 4G communication system. EX1046. An LTE communication standard was not defined until years after the '429 application was filed. EX1025; EX1026, 7 (LTE specification completed March 2009).

221. In litigation, Fractus argued that the claimed "*4G communication standard*" is met by LTE. *Supra* §VIII.G.2.

222. The '429 application provides no written description supporting the full scope of an “*antenna... being configured to transmit and receive signals from a 4G communication standard*” ([1.d]) or an “*antenna... configured to provide operation in at least [three or four] frequency bands being used by 4G communication standards*” ([6.b] and [11.b]) when the “*4G communication standard*” encompasses LTE. The '429 application provides no description of LTE, LTE frequency bands, or the 3GPP Technical Specification 36.101 V8.4.0 (2008-12)—published years *after* the '429 application's filing—that defines LTE and its frequency bands. Baliarda-543; EX1025; EX1026, 7 (LTE specification completed in March 2009); EX1039, 497-502.

223. On December 21, 2006, the LTE frequency bands *had not even been defined* and what frequency ranges they might eventually use was an “open issue.” EX1038 (February 2007 report), 112 (“Open issues... Is the evolved access system envisioned to work on new and/or existing frequency band?”); EX1037 (November 2006 report), 108 (same); EX1036 (June 2006 report), 84 (same); EX1039, 497-502 (LTE frequency bands); EX1025 (December 2008 document defining LTE bands), EX1026, 7 (LTE specification completed in March 2009).

224. 3GPP archives the version history for TR 23.882 at https://www.3gpp.org/ftp/Specs/archive/23_series/23.882/ (visited May 22, 2025).

225. The 3GPP TR 23.882 development and change control status is described here: <https://portal.3gpp.org/desktopmodules/Specifications/SpecificationDetails.aspx?specificationId=962> (visited May 22, 2025).

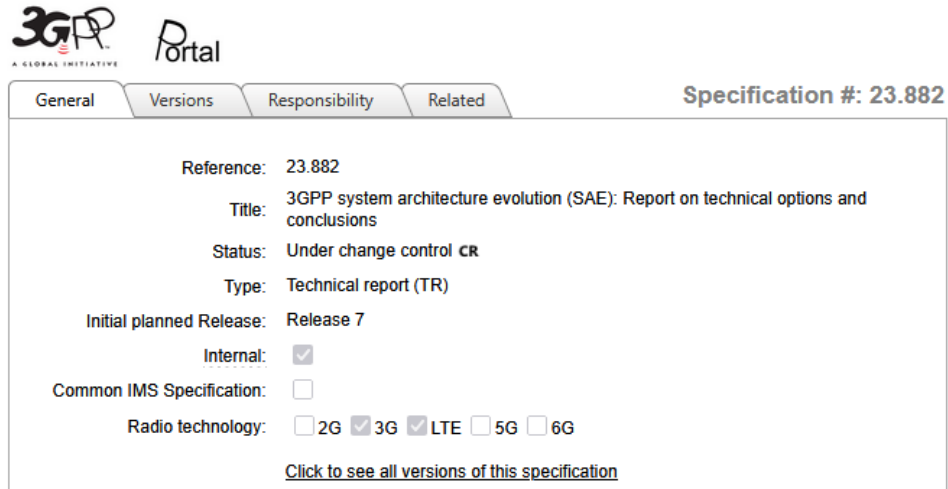

226. 3GPP summarizes the version releases, as relevant here, as follows at <https://portal.3gpp.org/desktopmodules/Specifications/SpecificationDetails.aspx?specificationId=962> (visited May 22, 2025):

Release 7 (Spec is Withdrawn from this Release at SA#36)

Latest Remark: (2015-01-22) Timed out of Rel-7, though the governing WI is (as...

Meetings	Version	Upload date	Comment			
-	1.9.0	2007-04-03			ETSI	TDoc CR
-	1.8.0	2007-02-21			ETSI	TDoc CR
-	1.7.0				ETSI	TDoc CR
-	1.6.1	2006-12-03			ETSI	TDoc CR
-	1.6.0	2006-11-28			ETSI	TDoc CR
-	1.5.0	2006-11-08			ETSI	TDoc CR
-	1.4.2	2006-10-12			ETSI	TDoc CR
RAN#33	1.4.1		RP-060613 for info		ETSI	TDoc CR
-	1.4.0	2006-09-12			ETSI	TDoc CR
-	1.3.0	2006-07-19			ETSI	TDoc CR
-	1.2.3	2006-06-15			ETSI	TDoc CR
-	1.2.2	2006-06-12			ETSI	TDoc CR
-	1.2.1	2006-06-12			ETSI	TDoc CR
-	1.2.0	2006-05-29			ETSI	TDoc CR
-	1.1.0	2006-04-20			ETSI	TDoc CR
SA#31	1.0.0	2006-03-20	SP-060152		ETSI	TDoc CR

227. The archived versions cited herein are highlighted in the excerpted screen capture below.

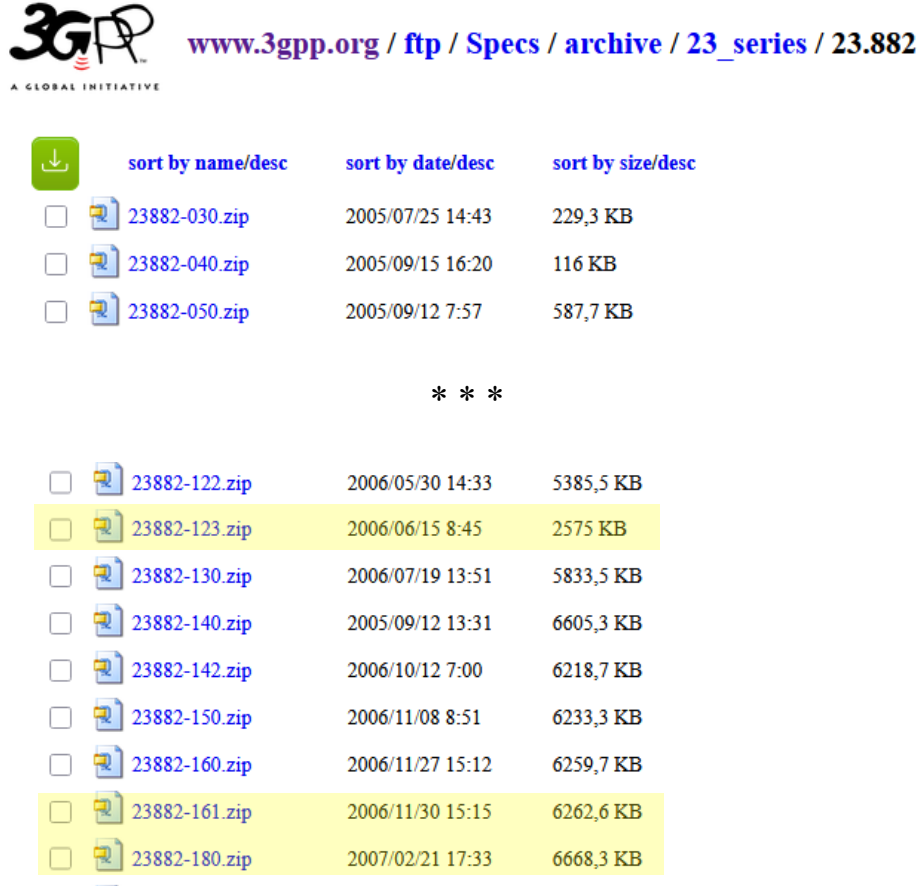

228. 3GPP archived the three reports cited above on these dates, before and after the '429 application's December 21, 2006 filing date:

Exhibit	Document	3GPP archive date
EX1038	3GPP TR 23.882 V1.8.0 (2007-02)	2007-02-21
EX1037	3GPP TR 23.882 V1.6.1 (2006-11)	2006-11-30
EX1036	3GPP TR 23.882 V1.2.3 (2006-06)	2006-06-15

229. POSAs would have understood that LTE band 12 (699-716 MHz uplink and 728-746 MHz downlink, EX1039, 498 (Table 20.1))—whose uplink

portion Fractus *expressly relies upon* for meeting limitation [11.b] in its complaint in the Geotab Litigation (EX1024, 27; *see also* [REDACTED]

[REDACTED])—is part of a frequency range (698-806 MHz) that was *not even available for use with mobile communications* (let alone LTE) until WRC-07 in October-November 2007—*nearly a year after* Fractus’s December 21, 2006 filing date for the ’429 application. EX1041, 1 (WRC-07 took place in Geneva, Switzerland between October 22 and November 16, 2007); EX1039, 501 (“20.1.2 New frequency bands... *WRC-07 identified additional frequency bands* for IMT, which encompasses both IMT-2000 and IMT-Advanced. *Several bands were defined by WRC-07* that will be available partly or fully for deployment on a global basis:... *698-806 MHz was allocated to mobile service* and identified to IMT to some extent in all regions. Together with the band 806-960 MHz identified at WRC-2000, it forms a wide frequency range from 698 to 960 MHz that is partly identified to IMT in all regions, with some variations.”).

230. Within this 698-806 MHz range defined for mobile communications at WRC-07, LTE bands 12, 13, and 14 (EX1039, 498 (Table 20.1)) were “defined for operation mainly for US allocations.” EX1039, 501.

231. Moreover in July 2007—before WRC-07—the spectrum at 698-806 MHz (spanning the frequencies where LTE bands 12, 13, and 14 were later defined) **was occupied by television broadcasters** in TV Channels 52-69. EX1045, 3. In other words, when PO filed the '429 application on December 21, 2006 the 698-806 MHz frequency range **was not available** for use in **any** cellular communication, let alone LTE or 4G communication.

232. Because the LTE frequency band definition was an “open issue” and the frequency ranges for LTE bands had not been selected, a POSA reading the '429 application on December 21, 2006 would have concluded that the applicants did **not** possess a wireless device with an antenna configured to support an LTE frequency band (a “*frequency band[] ... used by a 4G communication standard*”) or “*configured to transmit and receive*” LTE signals (“*signals from a 4G communication standard*”), let alone one that also met the complexity factors and other requirements of the Challenged Claims. On December 21, 2006, when the '429 application was filed, no one could have determined whether any antenna disclosed in the application was configured to support a “*frequency band[] used by*” LTE, or to send/receive LTE signals, because the LTE frequency bands had not yet even been defined.

233. When they filed the '429 application on December 21, 2006 **not even the applicants**—let alone a POSA reading the '429 application's specification—

could have determined whether an antenna was configured to operate at frequency ranges for a “*frequency band[] used by*” LTE, or to send/receive LTE signals, because the LTE frequency bands were undefined. A POSA would have concluded that on December 21, 2006 the applicants did not possess the idea of using an antenna sending or receiving signals in the 698-806 MHz spectrum—including the LTE band 12 that Fractus relies upon in litigation—for communication with any “*4G communication standard*” because on December 21, 2006 those frequencies were not usable for mobile device communications. In short, the applicants did not possess, and the priority documents cannot “describe,” claimed subject matter—antennas sending and receiving signals using LTE protocols on LTE frequency bands, neither of which existed at the time.

234. Thus, it is my opinion that the ’429 application fails to show that the applicants possessed the full scope of “*frequency band[] ... used by a 4G communication standard*” encompassing an LTE frequency band, or the full scope of “*antenna... configured to transmit and receive signals from a 4G communication standard*” that includes LTE (and LTE bands 12, 13, and 14).

235. The ’200 patent claims an antenna with specific “*complexity factors*” related to the antenna’s operating frequencies, but the ’429 application never teaches a POSA how to make or identify such an antenna for LTE because LTE did not exist. Based on the ’429 application’s disclosure no POSA would have

known how to design an LTE antenna, because in December 2006 nobody knew what frequency ranges such an antenna needed to support, or the antenna dimensions needed to support resonances for those unknown frequencies. EX1003, 25:23-26 (antenna has to support “radiation modes” for “frequency bands”).

236. The '429 application's suggestion that 4G would include bands within a 2-11 GHz frequency range (Baliarda-543, [0212]) provides no description of the 698-806 MHz frequency range that would later include LTE bands 12 to 14 (and which Fractus relies upon in litigation).

237. Indeed, the '429 application states that “the integration of an antenna system into the MFWD 100 is further complicated by the presence in the MFWD 100 of additional antennas... for reception of... TV[.]” Baliarda-543, [0096]. This *expressly excluded* an antenna receiving signals at 698-806 MHz from the claimed “antenna system” because on December 21, 2006 the 698-806 MHz frequency range was allocated to television could not be used for cellular communication. From the '429 application's description, it is my opinion that no POSA would have envisioned or recognized the 698-806 MHz frequency range as part of a 4G genus because in December 2006, that frequency range was allocated to television networks and could not be used for cellular communication.

B. Analysis

238. I was instructed by Petitioners’ counsel to assume that Baliarda-543 is prior art to claims 1-20.

239. I was asked to form an opinion whether a POSA would have concluded that the published parent case Baliarda-543, which has the same specification as the ’200 patent, anticipates or renders obvious Challenged Claims 1-20.

240. In forming these opinions, I was asked to consider the perspective of a POSA on **April 7, 2014**. I understand that this is the date on which the applicants filed a continuation of the ’429 application, which is the next continuation application in the ’200 patent’s priority chain, as summarized in EX1003, code (63).

241. In my opinion, a POSA would have concluded that Baliarda-543 anticipates and/or renders obvious each of Challenged Claims 1-20.

242. In the below chart, I identify where Baliarda-543 discloses the subject matter in each limitation in claims 1-20.

’200 claim limitation	Corresponding Disclosure in Baliarda-543
1.PRE	Abstract, [0002]
1.a	Abstract, [0082]-[0084], [0097], [0103], [0152], [0212]-[0217]
1.b	[0137], [0213]-[0215]

'200 claim limitation	Corresponding Disclosure in Baliarda-543
1.c	[0032]-[0035], [0098]-[0100], [0117]-[0118], [0212]-[0215], [0265], [0300], [0324]-[0325], Figs. 12A, 19A
1.d	<i>See</i> [1.c]; [0212]-[0215]
1.e	[0141]-[0144]
1.f	[0178], [0181]-[0183], [0213]
1.g	[0213] and [0228]-[0231]
1.h	<i>See</i> [1.c]; [0212]-[0215]
2	[0114]-[0116], [0133]-[0134], [0154]-[0162], [0213], [0226], [0227], Fig. 1B
3	[0141]-[0144], [0149]-[0151], [0271]
4	<i>See</i> [1.c]
5	<i>See</i> [1.c]
6.PRE	<i>See</i> [1.PRE]
6.a	<i>See</i> [1.a]
6.b	<i>See</i> [1.c] and [1.d]
6.c	<i>See</i> [1.c]
6.d	<i>See</i> [1.e]
6.e	<i>See</i> [1.f]
6.f	<i>See</i> [1.g] and [1.h]
6.g	<i>See</i> claim 2
6.h	<i>See</i> [1.b] and [1.g]
7	[0141]-[0149], [0270], Fig. 12A

'200 claim limitation	Corresponding Disclosure in Baliarda-543
8	<i>See</i> [1.g]
9	<i>See</i> claim 3
10	[0103], [0212]-[0215]
11.PRE	<i>See</i> [1.PRE]
11.a	<i>See</i> [1.a]
11.b	<i>See</i> [1.c] and [1.d]
11.c	<i>See</i> [1.e]
11.d	<i>See</i> claim 7
11.e	<i>See</i> [1.f]
11.f	<i>See</i> claim 2
11.g	<i>See</i> [1.h]
11.h	<i>See</i> [1.g]
12	<i>See</i> [1.c]
13	<i>See</i> [1.c]
14	<i>See</i> [1.c]
15	<i>See</i> claim 10
16	<i>See</i> claim 10
17	<i>See</i> claim 10
18	<i>See</i> claim 10 and [0032]-[0035], [0099] and [0212]
19	<i>See</i> claim 10
20	<i>See</i> claim 10

243. For Limitations [2], [6.g] and [11.f], Baliarda-543 at [0154]-[0162] says that the G_2 grid and the G_2 cell aspect ratio are determined based on the aspect ratio of the antenna rectangle. This describes a 9 column by $(2n + 1)$ row G_2 grid of cells—e.g., having an odd number $(2n + 1)$ of rows where n is an integer between 0 and 5 (for 1 to 11 rows)—wherein the aspect ratio of the cells is as close to 1 as possible. Baliarda-543 therefore describes an antenna rectangle wherein the G_2 grid has 9 columns by 1 row or 3 rows, with each cell as square as possible, which means that Baliarda-543 separately describes an antenna rectangle with an aspect ratio on the order of 9 or 3, e.g., more than 2 as recited in [2], [6.g] and [11.f].

XI. CONCLUSION

244. I declare that all statements made herein of my own knowledge are true, that all statements made on information and belief are believed to be true, and that these statements were made with the knowledge that willful false statements and the like are punishable by fine or imprisonment, or both, under Section 1001 of Title 18 of the United States Code.

245. I declare under penalty of perjury that the foregoing is true and correct.

Dated: June 5, 2025

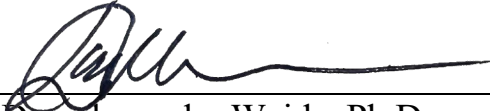
By: 
Daniel van der Weide, Ph.D.

APPENDIX A: MATERIALS CONSIDERED

Exhibit	Description
1001	U.S. Patent No. 11,031,677
1002	Prosecution History of U.S. Patent No. 11,031,677
1003	U.S. Patent No. 11,349,200
1004	Prosecution History of U.S. Patent No. 11,349,200
1005	U.S. Patent No. 12,095,149
1006	Prosecution History of U.S. Patent No. 12,095,149
1007	<i>intentionally left blank</i>
1008	Curriculum Vitae of Daniel van der Weide, Ph.D.
1009	P. Ciaï, R. Staraj, G. Kossiavas, and C. Luxey. "Design of an Internal Quad-Band Antenna for Mobile Phones," <i>IEEE Microwave and Wireless Components Letters</i> , vol. 14, no. 4, pp. 148-150, April 2004 ("Ciaï-Quadband").
1010	P. Ciaï, R. Staraj, G. Kossiavas, and C. Luxey. "Compact Internal Multiband Antenna for Mobile Phone and WLAN Standards," <i>Electronics Letters</i> , vol. 40, no. 15, pp. 920-921, July 2004 ("Ciaï-Multiband")
1011	X. Jing, Z. Du, and K. Gong. "Compact Planar Monopole Antenna for Multi-band Mobile Phones," in <i>2005 Asia-Pacific Microwave Conference Proceedings</i> , vol. 4, p. 2657-2660, IEEE, 2005 ("Jing").
1012	H. Nakano, Y. Sato, H. Mimaki and J. Yamauchi. "An Inverted FL Antenna for Dual-Frequency Operation," <i>IEEE Transactions on Antennas and Propagation</i> , vol. 53, no. 8, pp. 2417-2421, Aug. 2005 ("Nakano")
1013	U.S. Patent App. Pub. No. 2007/0200773 ("Dou")
1014	Declaration of James L. Mullins, Ph.D.

Exhibit	Description
1015	Curriculum Vitae of James L. Mullins, Ph.D.
1016	Plaintiff's Disclosure of Asserted Claims and Infringement Contentions Against Geotab Pursuant to Local Patent Rules 3-1 and 3-2, <i>Fractus, S.A., v. Geotab Inc.</i> , No. 2:24-cv-01008 (E.D. Tex.), served March 12, 2025
1017	D.I. 75, Fractus's Opening Claim Construction Brief, <i>Fractus, S.A. v. ADT LLC</i> , No. 2:22-cv-00412 (E.D. Tex. Nov. 16, 2023)
1018	D.I. 75-1, Exhibit 1 to D.I. 75, Fractus's Opening Claim Construction Brief, <i>Fractus, S.A. v. ADT LLC</i> , No. 2:22-cv-00412 (E.D. Tex. Nov. 16, 2023)
1019	D.I. 92, Joint Claim Construction Chart, <i>Fractus, S.A. v. ADT LLC</i> , No. 2:22-cv-00412 (E.D. Tex. Jan. 4, 2024)
1020	D.I. 115, Claim Construction Order, <i>Fractus, S.A. v. ADT LLC</i> , No. 2:22-cv-00412 (E.D. Tex. Feb. 25, 2024) (Payne, M.J.)
1021	D.I. 127, Order, <i>Fractus, S.A. v. ADT LLC</i> , No. 2:22-cv-00412 (E.D. Tex. Mar. 15, 2024) (Gilstrap, D.J.)
1022	D.I. 82, Defendants ADT LLC and Vivint, Inc.'s Responsive Claim Construction Brief, <i>Fractus, S.A. v. ADT LLC</i> , No. 2:22-cv-00412 (E.D. Tex. Dec. 14, 2023)
1023	D.I. 253, Order, <i>Fractus, S.A. v. ADT LLC</i> , No. 2:22-cv-00412 (E.D. Tex. Oct. 4, 2024) (Gilstrap, D.J.)
1024	D.I. 1, Complaint, <i>Fractus, S.A., v. Geotab Inc.</i> , No. 2:24-cv-01008 (E.D. Tex. Dec. 6, 2024)
1025	3GPP TS 36.101 v8.4.0 (2008-12) Technical Specification: 3rd Generation Partnership Project; Technical Specification Group Radio Access Network; Evolved Universal Terrestrial Radio Access (E-UTRA); User Equipment (UE) radio transmission and reception (Release 8), 2008

Exhibit	Description
1026	Ericsson white paper, "LTE—an introduction," no. 284 23-3124 Uen Rev B (June 2009)
1027	Declaration of Gordon MacPherson
1028	'200 patent Claim Limitation Comparison Chart
1029	U.S. Patent Publication No. 2006/0214857 ("Ollikainen")
1030	ETSI TS 145 005 V4.3.0 (2001-14) Technical Specification: Digital cellular telecommunications system (Phase 2+); Radio transmission and reception (3GPP TS 45.005 version 4.3.0 Release 4)
1031	ZigBee Specification (Jun. 27, 2005)
1032	ETSI TS 125 308 V6.2.0 (2004-09) Technical Specification: Universal Mobile Telecommunications System (UMTS); UTRA High Speed Downlink Packet Access (HSDPA); Overall description; Stage 2 (3GPP TS 25.308 version 6.2.0 Release 6)
1033	ETSI TS 125 101 V6.5.0 (2004-09) Technical Specification: Universal Mobile Telecommunications System (UMTS); User Equipment (UE) radio transmission and reception (FDD) (3GPP TS 25.101 version 6.5.0 Release 6)
1034	ETSI TS 125 102 V6.0.0 (2003-12) Technical Specification: Universal Mobile Telecommunications System (UMTS); User Equipment (UE) radio transmission and reception (TDD) (3GPP TS 25.102 version 6.0.0 Release 6)
1035	ETSI TS 121 101 V6.0.0 (2004-12) Technical Specification: Universal Mobile Telecommunications System (UMTS); Technical Specifications and Technical Reports for a UTRAN-based 3GPP system (3GPP TS 21.101 version 6.0.0 Release 6)
1036	3GPP TR 23.882 V1.2.3 (2006-06) Technical Report: 3rd Generation Partnership Project; Technical Specification Group Services and System Aspects; 3GPP System Architecture Evolution: Report on Technical Options and Conclusions (Release 7)

Exhibit	Description
1037	3GPP TR 23.882 V1.6.1 (2006-11) Technical Report: 3rd Generation Partnership Project; Technical Specification Group Services and System Aspects; 3GPP System Architecture Evolution: Report on Technical Options and Conclusions (Release 7)
1038	3GPP TR 23.882 V1.8.0 (2007-02) Technical Report: 3rd Generation Partnership Project; Technical Specification Group Services and System Aspects; 3GPP System Architecture Evolution: Report on Technical Options and Conclusions (Release 7)
1039	pages from E. Dahlman et al., <i>3G Evolution: HSPA and LTE for Mobile Broadband</i> (Academic Press 2d ed. 2008)
1040	U.S. Patent Publication No. 2008/0018543 (Baliarda-543)
1041	U.S. Department of State, <i>United States Delegation Report: World Radiotelecommunications Conference 2007</i> (2007), available at https://2001-2009.state.gov/documents/organization/108955.pdf (visited May 19, 2025)
1042	IEEE Std. 802.11a-1999, Supplement to the IEEE Standard for Information Technology—Telecommunications and information exchange between systems—Local and metropolitan area networks—Specific requirements— Part 11: Wireless LAN Medium Access Control (MAC) and Physical Layer (PHY) specifications: High-speed Physical Layer in the 5 GHz Band (Dec. 30, 1999)
1043	IEEE Std. 802.11b-1999, Supplement to the IEEE Standard for Information Technology—Telecommunications and information exchange between systems—Local and metropolitan area networks—Specific requirements— Part 11: Wireless LAN Medium Access Control (MAC) and Physical Layer (PHY) specifications: Higher-Speed Physical Layer Extension in the 2.4 GHz Band (Jan. 20, 2000)
1044	Specification of the Bluetooth System version 2.0, volume 2 (issued Nov. 4, 2004)

Exhibit	Description
1045	<p>Second Report and Order, <i>In re Service Rules for the 698-746, 747-762 and 777-792 MHz Bands</i> (WT Docket No. 06-150); <i>Revision of the Commission's Rules to Ensure Compatibility with Enhanced 911 Emergency Calling Systems</i> (CC Docket No. 94-102); <i>Section 68.4(a) of the Commission's Rules Governing Hearing Aid-Compatible Telephones</i> (WT Docket No. 01-309); <i>Biennial Regulatory Review—Amendment of Parts 1, 22, 24, 27, and 90 to Streamline and Harmonize Various Rules Affecting Wireless Radio Services</i> (WT Docket No. 03-264); <i>Former Nextel Communications, Inc. Upper 700 MHz Guard Band Licenses and Revisions to Part 27 of the Commission's Rules</i> (WT Docket No. 06-169); <i>Implementing a Nationwide, Broadband, Interoperable Public Safety Network in the 700 MHz Band</i> (PS Docket No. 06-229); <i>Development of Operational, Technical and Spectrum Requirements for Meeting Federal, State and Local Public Safety Communications Requirements Through the Year 2010</i> (WT Docket No. 96-86); <i>Declaratory Ruling on Reporting Requirement under Commission's Part 1 Anti-Collusion Rule</i> (WT Docket No. 07-166), FCC 07-132 (Jul. 31, 2007), available at https://docs.fcc.gov/public/attachments/FCC-07-132A1.pdf (visited May 21, 2025)</p>
1046	<p>ITU, Report ITU-R M.2134-0: Requirements related to technical performance for IMT-Advanced radio interface(s) (2008), available at https://www.itu.int/pub/R-REP-M.2134-2008/en (visited May 22, 2025)</p>
1047	<p>Reexamination History of U.S. Patent No. 11,349,200</p>
1048	<p>Global Positioning System Standard Positioning Server (SPS) Performance Standard (October 2001), available at https://www.gps.gov/technical/ps/2001-SPS-performance-standard.pdf</p>
1049	<p>Chart 49 to EX1016 [confidential]</p>
1050	<p>Chart 50 to EX1016 [confidential]</p>
1051	<p>Chart 51 to EX1016 [confidential]</p>
1052	<p>Chart 52 to EX1016 [confidential]</p>
1053	<p>Chart 53 to EX1016 [confidential]</p>

Exhibit	Description
1054	Chart 54 to EX1016 [confidential]
1055	Chart 55 to EX1016 [confidential]
1056	Chart 56 to EX1016 [confidential]
1057	Chart 57 to EX1016 [confidential]
1058	Chart 58 to EX1016 [confidential]
1059	Chart 59 to EX1016 [confidential]
1060	Wi-Fi Alliance Press Release, "Wi-Fi Celebrates Its Third Birthday" (Apr. 7, 2003) (Wayback Machine copy dated Sep. 28, 2003)

APPENDIX B: U.S. PATENT NO. 11,349,200 CLAIM LIST

REF	Limitation
1.PRE	A wireless device comprising:
1.a	an antenna system comprising a ground plane and at least two antennas within the wireless device, the antenna system comprising:
1.b	a first antenna proximate to a first short side of a ground plane rectangle enclosing the ground plane,
1.c	the first antenna being configured to support at least three frequency bands contained within first and second frequency ranges of the electromagnetic spectrum, the second frequency range being higher in frequency than the first frequency range,
1.d	the first antenna being configured to transmit and receive signals from a 4G communication standard,
1.e	the first antenna defining a first antenna contour comprising an entire perimeter of the first antenna,
1.f	wherein the first antenna contour has a level of complexity defined by complexity factor F_{21} having a value of at least 1.20 and complexity factor F_{32} having a value of at least 1.35; and
1.g	a second antenna proximate to a first long side of the ground plane rectangle,
1.h	and wherein the second antenna is configured to receive signals from a 4G communication standard.

REF	Limitation
2	The wireless device of claim 1, wherein the second antenna defines an antenna box that is a minimum-sized parallelepiped that completely encloses a volume of the second antenna and wherein each face of the minimum-sized parallelepiped is tangent to at least one point of the volume of the second antenna, an orthogonal projection of the antenna box along a normal to a face with a largest area of the second antenna defining an antenna rectangle, an aspect ratio of the antenna rectangle being defined as a ratio between a width and a height of the antenna rectangle, and wherein the aspect ratio has a value of at least 2.
3	The wireless device of claim 2, wherein the second antenna defines a second antenna contour comprising an entire perimeter of the second antenna, wherein a length of the second antenna contour is greater than four times a diagonal of the antenna rectangle.
4	The wireless device of claim 1, wherein the first antenna is configured to support at least four frequency bands.
5	The wireless device of claim 1, wherein the first antenna is configured to support at least five frequency bands.
6.PRE	A wireless device comprising:
6.a	an antenna system comprising a ground plane and at least two antennas within the wireless device, the antenna system comprising:
6.b	a first antenna configured to provide operation in at least four frequency bands being used by 4G communication standards,

REF	Limitation
6.c	wherein at least two of the at least four frequency bands are contained within a first frequency range and at least two of the four frequency bands are contained within a second frequency range, the first frequency range being lower in frequency than the second frequency range,
6.d	the first antenna defining a first antenna contour comprising an entire perimeter of the first antenna, and
6.e	wherein the first antenna contour has a level of complexity defined by complexity factor F_{21} having a value of at least 1.20 and complexity factor F_{32} having a value of at least 1.35; and
6.f	a second antenna configured to operate in at least one frequency band being used by a 4G communication standard,
6.g	the second antenna defining an antenna box that is a minimum-sized parallelepiped that completely encloses a volume of the second antenna and wherein each face of the minimum-sized parallelepiped is tangent to at least one point of the volume of the second antenna, an orthogonal projection of the antenna box along a normal to a face with a largest area of the second antenna defining an antenna rectangle, an aspect ratio of the antenna rectangle being defined as a ratio between a width and a height of the antenna rectangle, and wherein the aspect ratio has a value of at least 2,
6.h	and wherein at least one of the first and second antennas is close to a first short side of a ground plane rectangle enclosing the ground plane.
7	The wireless device of claim 6, wherein the first antenna contour comprises at least 20 segments.

REF	Limitation
8	The wireless device of claim 6, wherein at least one of the first and second antennas is close to a first long side of the ground plane rectangle.
9	The wireless device of claim 6, wherein the second antenna defines a second antenna contour comprising an entire perimeter of the second antenna, wherein a length of the second antenna contour is greater than four times a diagonal of the antenna rectangle.
10	The wireless device of claim 6, wherein the antenna system comprises a third antenna configured to provide operation in a wireless communication standard.
11.PRE	A wireless device comprising:
11.a	an antenna system comprising a ground plane and at least two antennas within the wireless device, the antenna system comprising:
11.b	a first antenna configured to provide operation in at least three frequency bands being used by 4G communication standards,
11.c	the first antenna defining an antenna contour comprising an entire perimeter of the first antenna,
11.d	the antenna contour comprising at least twenty segments,
11.e	wherein the antenna contour has a level of complexity defined by complexity factor F_{21} having a value of at least 1.20 and complexity factor F_{32} having a value of at least 1.35,

REF	Limitation
11.f	and wherein the first antenna defines an antenna box that is a minimum-sized parallelepiped that completely encloses a volume of the first antenna and wherein each face of the minimum-sized parallelepiped is tangent to at least one point of the volume of the first antenna, an orthogonal projection of the antenna box along a normal to a face with a largest area of the first antenna defining an antenna rectangle, an aspect ratio of the antenna rectangle being defined as a ratio between a width and a height of the antenna rectangle, wherein the aspect ratio has a value of at least 2; and
11.g	a second antenna configured to provide operation in a first wireless service,
11.h	the second antenna being proximate to a side of a ground plane rectangle enclosing the ground plane.
12	The wireless device of claim 11, wherein the first antenna is configured to support at least four frequency bands.
13	The wireless device of claim 11, wherein the first wireless service is a WiFi communication standard.
14	The wireless device of claim 13, wherein the first wireless service provides operation in the 2400-2480 MHz frequency range and the 5.1-5.9 GHz frequency range.
15	The wireless device of claim 11, wherein the antenna system comprises a third antenna.
16	The wireless device of claim 15, wherein the third antenna is configured to provide operation in the first wireless service.

REF	Limitation
17	The wireless device of claim 15, wherein the third antenna is configured to provide operation in a second wireless service.
18	The wireless device of claim 17, wherein the second wireless service provides operation in the 902-928 MHz frequency range.
19	The wireless device of claim 15, wherein the antenna system comprises a fourth antenna.
20	The wireless device of claim 19, wherein the fourth antenna is configured to provide operation in a third wireless service.