

Filed on behalf of Petitioners by:

Adam R. Wichman, Reg. No. 43,988  
Michael Parsons, Reg. No. 58,767  
Shangxing (Simon) Lu, Reg. No. 80,263  
Richard F. Giunta, Reg. No. 36,149  
WOLF, GREENFIELD & SACKS, P.C.  
600 Atlantic Avenue  
Boston, MA 02210  
(617) 646-8000 Phone  
(617) 646-8646 Fax

UNITED STATES PATENT AND TRADEMARK OFFICE

---

BEFORE THE PATENT TRIAL AND APPEAL BOARD

---

GEOTAB INC. AND GEOTAB USA, INC.,  
Petitioners,

v.

FRACTUS, S.A.  
Patent Owner.

---

Case No. IPR2025-01027  
Patent No. 11,349,200

---

**PETITION FOR *INTER PARTES* REVIEW  
UNDER 35 U.S.C. §§ 311-319 AND 37 C.F.R. § 42.1 et seq**

**TABLE OF CONTENTS**

I. INTRODUCTION .....1

II. STANDING CERTIFICATION.....3

III. UNPATENTABILITY GROUNDS.....3

IV. '200 PATENT.....5

    A. POSA .....9

    B. Prosecution History .....9

    C. Challenged Claims.....11

V. CLAIM INTERPRETATION .....11

    A. “*perimeter*” (all claims).....12

    B. “*antenna box*” (claims 2, 6-20) .....13

    C. “*antenna rectangle*” (claims 2-3, 6-20).....14

    D. “*antenna contour*” (all claims) .....14

    E. “*complexity factor,*” “*F<sub>21</sub>,*” “*F<sub>32</sub>*” (all claims) .....16

        1. Grids .....17

        2. Calculation.....22

        3. Fractus’s ADT Litigation argument .....26

    F. “*wireless device*” (all claims) .....26

    G. “*4G communication standard*” terms (all claims).....26

        1. Intrinsic evidence .....28

        2. Fractus’s Litigation Arguments.....29

VI. GROUND 1: Dou+Jing Renders Obvious Claims 1-15, 17, and 19-20 .....31

    A. Dou (EX1013) .....31

    B. Jing (EX1011).....31

    C. Dou+Jing .....33

    D. Analysis .....40

        1. Claim 1 .....40

        2. Claim 2 .....59

        3. Claim 3 .....60

4. Claims 4, 5.....	64
5. Claim 6 .....	64
6. Claim 7 .....	67
7. Claim 8 .....	68
8. Claim 9 .....	68
9. Claim 10 .....	68
10. Claim 11 .....	69
11. Claim 12 .....	70
12. Claim 13 .....	70
13. Claim 14 .....	71
14. Claim 15, 17 .....	71
15. Claims 19, 20.....	72
VII. GROUND 2: BALIARDA-543 ANTICIPATES AND/OR RENDERS OBVIOUS CLAIMS 1-20 .....	73
A. Claims 1-20 Are Not Entitled To Priority Before April 7, 2014. ....	73
B. Analysis .....	81
VIII. <i>Sotera</i> .....	84
IX. Discretionary Denial Is Unwarranted .....	85
X. CONCLUSION.....	86
Appendix A: U.S. Patent No. 11,349,200 Claim List.....	87

## TABLE OF AUTHORITIES

### CASES

<i>10X Genomics v. Bio-Rad Labs.</i> , IPR2020-00086, Paper 8 (April 27, 2020) .....	27
<i>Ariad Pharms., Inc. v. Eli Lilly &amp; Co.</i> , 598 F.3d 1336 (Fed. Cir. 2010) (en banc) .....	73, 80
<i>Arthrex, Inc. v. Smith &amp; Nephew, Inc.</i> , 35 F.4th 1328 (Fed. Cir. 2022) .....	73, 79
<i>Chester v. Miller</i> , 906 F.2d 1574 (Fed. Cir. 1990) .....	81
<i>Google LLC v. Valtrus Innovations Ltd.</i> , IPR2022-01406, Paper 40 (Apr. 3, 2024) .....	74
<i>ICU Medical, Inc. v. Alaris Med. Sys., Inc.</i> , 558 F.3d 1368 (Fed. Cir. 2009) .....	74, 79
<i>KSR Int’l v. Teleflex</i> , 550 U.S. 398 (2007) .....	37, 38
<i>Nidec Motor Corp. v. Zhongshan Broad Ocean Motor Co.</i> , 868 F.3d 1013 (Fed. Cir. 2017) .....	11, 27
<i>Phil-Insul Corp. v. Airlite Plastics Co.</i> , 854 F.3d 1344 (Fed. Cir. 2017) .....	12
<i>Phillips v. AWH Corp.</i> , 415 F.3d 1303 (Fed. Cir. 2005) (en banc) .....	passim
<i>Regents of the Univ. of Cal. v. Broad Inst., Inc.</i> , No. 22-1653, slip op. (Fed. Cir. May 12, 2025) .....	73
<i>Rivera v. Int’l Trade Comm’n</i> , 857 F.3d 1315 (Fed. Cir. 2017) .....	74, 79
<i>Smith &amp; Nephew, Inc. v. Arthrex, Inc.</i> , IPR2017-00275, Paper 36 (May 2, 2018) .....	79

*Sotera Wireless, Inc. v. Masimo Corp.*,  
IPR2020-01019, Paper 12 (Dec. 1, 2020) (precedential as to §II.A)..... 84, 85

**STATUTES**

35 U.S.C. §102.....3, 4  
35 U.S.C. §102(a)(1).....4, 5  
35 U.S.C. §102 (2012) .....5  
35 U.S.C. §102(a) (2012).....4  
35 U.S.C. §102(e) (2012).....4  
35 U.S.C. §103 .....3, 4  
35 U.S.C. §103 (2012) .....3  
35 U.S.C. §282(b) .....11  
Leahy-Smith America Invents Act, Pub. L. 112-29, §3(n)(1)(A), 125 Stat.  
284, 293 (Sep. 16, 2011) .....3

**REGULATIONS**

37 C.F.R. §42.100(b) .....11  
37 C.F.R. §42.104(a).....3  
37 C.F.R. §42.104(b)(3).....27

**OTHER AUTHORITIES**

C. Stewart, Interim Processes for PTAB Workload Management (Mar. 26,  
2025).....85  
Examination Guidelines for Implementing the First Inventor To File  
Provisions of the Leahy-Smith America Invents Act, 78 Fed. Reg. 11059,  
11083 (Feb. 14, 2013) .....3  
PTAB FAQs for Interim Processes for PTAB Workload Management,  
available at <https://www.uspto.gov/patents/ptab/faqs/interim-processes-workload-management> (visited May 28, 2025) .....85

# MANUAL OF PATENT EXAMINING PROCEDURE

United States Patent and Trademark Office, Manual of Patent Examining  
Procedures §2159.02 (9th ed., rev Nov. 2024 [R-01.2024]).....4

## EXHIBIT LIST

<b>Exhibit</b>	<b>Description</b>
1001	U.S. Patent No. 11,031,677
1002	Prosecution History of U.S. Patent No. 11,031,677
1003	U.S. Patent No. 11,349,200
1004	Prosecution History of U.S. Patent No. 11,349,200
1005	U.S. Patent No. 12,095,149
1006	Prosecution History of U.S. Patent No. 12,095,149
1007	Declaration of Daniel van der Weide, Ph.D.
1008	Curriculum Vitae of Daniel van der Weide, Ph.D.
1009	P. Ciais, R. Staraj, G. Kossiavas, and C. Luxey. "Design of an Internal Quad-Band Antenna for Mobile Phones," <i>IEEE Microwave and Wireless Components Letters</i> , vol. 14, no. 4, pp. 148-150, April 2004 ("Ciais-Quadband").
1010	P. Ciais, R. Staraj, G. Kossiavas, and C. Luxey. "Compact Internal Multiband Antenna for Mobile Phone and WLAN Standards," <i>Electronics Letters</i> , vol. 40, no. 15, pp. 920-921, July 2004 ("Ciais-Multiband")
1011	X. Jing, Z. Du, and K. Gong. "Compact Planar Monopole Antenna for Multi-band Mobile Phones," in <i>2005 Asia-Pacific Microwave Conference Proceedings</i> , vol. 4, p. 2657-2660, IEEE, 2005 ("Jing").
1012	H. Nakano, Y. Sato, H. Mimaki and J. Yamauchi. "An Inverted FL Antenna for Dual-Frequency Operation," <i>IEEE Transactions on Antennas and Propagation</i> , vol. 53, no. 8, pp. 2417-2421, Aug. 2005 ("Nakano")
1013	U.S. Patent App. Pub. No. 2007/0200773 ("Dou")
1014	Declaration of James L. Mullins, Ph.D.

Exhibit	Description
1015	Curriculum Vitae of James L. Mullins, Ph.D.
1016	Plaintiff's Disclosure of Asserted Claims and Infringement Contentions Against Geotab Pursuant to Local Patent Rules 3-1 and 3-2, <i>Fractus, S.A., v. Geotab Inc.</i> , No. 2:24-cv-01008 (E.D. Tex.), served March 12, 2025
1017	D.I. 75, Fractus's Opening Claim Construction Brief, <i>Fractus, S.A. v. ADT LLC</i> , No. 2:22-cv-00412 (E.D. Tex. Nov. 16, 2023)
1018	D.I. 75-1, Exhibit 1 to D.I. 75, Fractus's Opening Claim Construction Brief, <i>Fractus, S.A. v. ADT LLC</i> , No. 2:22-cv-00412 (E.D. Tex. Nov. 16, 2023)
1019	D.I. 92, Joint Claim Construction Chart, <i>Fractus, S.A. v. ADT LLC</i> , No. 2:22-cv-00412 (E.D. Tex. Jan. 4, 2024)
1020	D.I. 115, Claim Construction Order, <i>Fractus, S.A. v. ADT LLC</i> , No. 2:22-cv-00412 (E.D. Tex. Feb. 25, 2024) (Payne, M.J.)
1021	D.I. 127, Order, <i>Fractus, S.A. v. ADT LLC</i> , No. 2:22-cv-00412 (E.D. Tex. Mar. 15, 2024) (Gilstrap, D.J.)
1022	D.I. 82, Defendants ADT LLC and Vivint, Inc.'s Responsive Claim Construction Brief, <i>Fractus, S.A. v. ADT LLC</i> , No. 2:22-cv-00412 (E.D. Tex. Dec. 14, 2023)
1023	D.I. 253, Order, <i>Fractus, S.A. v. ADT LLC</i> , No. 2:22-cv-00412 (E.D. Tex. Oct. 4, 2024) (Gilstrap, D.J.)
1024	D.I. 1, Complaint, <i>Fractus, S.A., v. Geotab Inc.</i> , No. 2:24-cv-01008 (E.D. Tex. Dec. 6, 2024)
1025	3GPP TS 36.101 v8.4.0 (2008-12) Technical Specification: 3rd Generation Partnership Project; Technical Specification Group Radio Access Network; Evolved Universal Terrestrial Radio Access (E-UTRA); User Equipment (UE) radio transmission and reception (Release 8), 2008

<b>Exhibit</b>	<b>Description</b>
1026	Ericsson white paper, "LTE—an introduction," no. 284 23-3124 Uen Rev B (June 2009)
1027	Declaration of Gordon MacPherson
1028	'200 patent Claim Limitation Comparison Chart
1029	U.S. Patent Publication No. 2006/0214857 ("Ollikainen")
1030	ETSI TS 145 005 V4.3.0 (2001-14) Technical Specification: Digital cellular telecommunications system (Phase 2+); Radio transmission and reception (3GPP TS 45.005 version 4.3.0 Release 4)
1031	ZigBee Specification (Jun. 27, 2005)
1032	ETSI TS 125 308 V6.2.0 (2004-09) Technical Specification: Universal Mobile Telecommunications System (UMTS); UTRA High Speed Downlink Packet Access (HSDPA); Overall description; Stage 2 (3GPP TS 25.308 version 6.2.0 Release 6)
1033	ETSI TS 125 101 V6.5.0 (2004-09) Technical Specification: Universal Mobile Telecommunications System (UMTS); User Equipment (UE) radio transmission and reception (FDD) (3GPP TS 25.101 version 6.5.0 Release 6)
1034	ETSI TS 125 102 V6.0.0 (2003-12) Technical Specification: Universal Mobile Telecommunications System (UMTS); User Equipment (UE) radio transmission and reception (TDD) (3GPP TS 25.102 version 6.0.0 Release 6)
1035	ETSI TS 121 101 V6.0.0 (2004-12) Technical Specification: Universal Mobile Telecommunications System (UMTS); Technical Specifications and Technical Reports for a UTRAN-based 3GPP system (3GPP TS 21.101 version 6.0.0 Release 6)
1036	3GPP TR 23.882 V1.2.3 (2006-06) Technical Report: 3rd Generation Partnership Project; Technical Specification Group Services and System Aspects; 3GPP System Architecture Evolution: Report on Technical Options and Conclusions (Release 7)

Exhibit	Description
1037	3GPP TR 23.882 V1.6.1 (2006-11) Technical Report: 3rd Generation Partnership Project; Technical Specification Group Services and System Aspects; 3GPP System Architecture Evolution: Report on Technical Options and Conclusions (Release 7)
1038	3GPP TR 23.882 V1.8.0 (2007-02) Technical Report: 3rd Generation Partnership Project; Technical Specification Group Services and System Aspects; 3GPP System Architecture Evolution: Report on Technical Options and Conclusions (Release 7)
1039	pages from E. Dahlman et al., <i>3G Evolution: HSPA and LTE for Mobile Broadband</i> (Academic Press 2d ed. 2008)
1040	U.S. Patent Publication No. 2008/0018543 (Baliarda-543)
1041	U.S. Department of State, <i>United States Delegation Report: World Radiotelecommunications Conference 2007</i> (2007), available at <a href="https://2001-2009.state.gov/documents/organization/108955.pdf">https://2001-2009.state.gov/documents/organization/108955.pdf</a> (visited May 19, 2025)
1042	IEEE Std. 802.11a-1999, Supplement to the IEEE Standard for Information Technology—Telecommunications and information exchange between systems—Local and metropolitan area networks—Specific requirements— Part 11: Wireless LAN Medium Access Control (MAC) and Physical Layer (PHY) specifications: High-speed Physical Layer in the 5 GHz Band (Dec. 30, 1999)
1043	IEEE Std. 802.11b-1999, Supplement to the IEEE Standard for Information Technology—Telecommunications and information exchange between systems—Local and metropolitan area networks—Specific requirements— Part 11: Wireless LAN Medium Access Control (MAC) and Physical Layer (PHY) specifications: Higher-Speed Physical Layer Extension in the 2.4 GHz Band (Jan. 20, 2000)
1044	Specification of the Bluetooth System version 2.0, volume 2 (issued Nov. 4, 2004)
1045	Second Report and Order, <i>In re Service Rules for the 698-746, 747-762 and 777-792 MHz Bands (WT Docket No. 06-150); Revision of the</i>

Exhibit	Description
	<p><i>Commission’s Rules to Ensure Compatibility with Enhanced 911 Emergency Calling Systems (CC Docket No. 94-102); Section 68.4(a) of the Commission’s Rules Governing Hearing Aid-Compatible Telephones (WT Docket No. 01-309); Biennial Regulatory Review–Amendment of Parts 1, 22, 24, 27, and 90 to Streamline and Harmonize Various Rules Affecting Wireless Radio Services (WT Docket No. 03-264); Former Nextel Communications, Inc. Upper 700 MHz Guard Band Licenses and Revisions to Part 27 of the Commission’s Rules (WT Docket No. 06-169); Implementing a Nationwide, Broadband, Interoperable Public Safety Network in the 700 MHz Band (PS Docket No. 06-229); Development of Operational, Technical and Spectrum Requirements for Meeting Federal, State and Local Public Safety Communications Requirements Through the Year 2010 (WT Docket No. 96-86); Declaratory Ruling on Reporting Requirement under Commission’s Part 1 Anti-Collusion Rule (WT Docket No. 07-166), FCC 07-132 (Jul. 31, 2007), available at <a href="https://docs.fcc.gov/public/attachments/FCC-07-132A1.pdf">https://docs.fcc.gov/public/attachments/FCC-07-132A1.pdf</a> (visited May 21, 2025)</i></p>
1046	<p>ITU, Report ITU-R M.2134-0: Requirements related to technical performance for IMT-Advanced radio interface(s) (2008), available at <a href="https://www.itu.int/pub/R-REP-M.2134-2008/en">https://www.itu.int/pub/R-REP-M.2134-2008/en</a> (visited May 22, 2025)</p>
1047	<p>Reexamination History of U.S. Patent No. 11,349,200</p>
1048	<p>Global Positioning System Standard Positioning Server (SPS) Performance Standard (October 2001), available at <a href="https://www.gps.gov/technical/ps/2001-SPS-performance-standard.pdf">https://www.gps.gov/technical/ps/2001-SPS-performance-standard.pdf</a></p>
1049	<p>Chart 49 to EX1016 [confidential]</p>
1050	<p>Chart 50 to EX1016 [confidential]</p>
1051	<p>Chart 51 to EX1016 [confidential]</p>
1052	<p>Chart 52 to EX1016 [confidential]</p>
1053	<p>Chart 53 to EX1016 [confidential]</p>
1054	<p>Chart 54 to EX1016 [confidential]</p>

<b>Exhibit</b>	<b>Description</b>
1055	Chart 55 to EX1016 [confidential]
1056	Chart 56 to EX1016 [confidential]
1057	Chart 57 to EX1016 [confidential]
1058	Chart 58 to EX1016 [confidential]
1059	Chart 59 to EX1016 [confidential]
1060	Wi-Fi Alliance Press Release, “Wi-Fi Celebrates Its Third Birthday” (Apr. 7, 2003) (Wayback Machine copy dated Sep. 28, 2003)

## ABBREVIATIONS

Abbreviation	Description
3GPP	3rd Generation Partnership Project
DCS	Digital Communication Service
DL	downlink
ETSI	European Telecommunication Standards Institute
E-UTRAN	Evolved Universal Terrestrial Radio Access Network
FDD	frequency division duplexing
GPS	Global Positioning System
GSM	Global System for Mobile Communications
HSDPA	High Speed Downlink Packet Access
HSPA	High Speed Packet Access
HSUPA	High Speed Uplink Packet Access
ISM	Industrial, Scientific, and Medical
LTE	Long Term Evolution
NAMPS	Narrowband Advanced Mobile Phone Service
PCB	printed circuit board
PCS	Personal Communication Service
PDA	personal digital assistant
PIFA	planar inverted-F antenna
TDD	time division duplexing
UL	uplink

<b>Abbreviation</b>	<b>Description</b>
UMTS	Universal Mobile Telecommunications System
UTRAN	UMTS Terrestrial Radio Access Network
UWB	ultra-wideband
VSWR	voltage standing wave ratio
WCDMA	Wideband Code Division Multiple Access
WiBro	Wireless Broadband
WiMax	Worldwide Interoperability for Microwave Access
WLAN	wideband local area network
WRC	World Radiocommunication Conference

## MANDATORY NOTICES

### **A. Real Party-In-Interest**

Petitioners Geotab USA Inc. and Geotab Inc. (collectively “Geotab”) are real parties-in-interest under 37 C.F.R. §42.8(b)(1).

### **B. Related Matters**

A decision in this proceeding could affect, or be affected by, the following:

#### **1. United States Patent & Trademark Office**

The application from which U.S. Patent No. 11,349,200 (“the ’200 patent”) issued (U.S. Patent Application No. 17/246,192) is a Continuation of U.S. Patent Application No. 16/832,820 (U.S. Patent No. 11,031,677) filed March 27, 2020, which is a Continuation of U.S. Patent Application No. 15/856,626 (U.S. Patent No. 10,644,380) filed December 28, 2017, which is a Continuation of U.S. Patent Application No. 14/738,090 (U.S. Patent No. 9,899,727) filed June 12, 2015, which is a Continuation of U.S. Patent Application No. 14/246,491 (U.S. Patent No. 9,099,773) filed April 7, 2014, which is a Continuation of U.S. Patent Application No. 11/614,429 (U.S. Patent No. 8,738,103) filed December 21, 2006, which claims priority from Provisional Application No. 60/856,410 filed November 3, 2006 and Provisional Application No. 60/831,544 filed July 18, 2006.

The following applications are Continuations of the ’200 patent:

- U.S. Patent Application No. 17/704,942 (U.S. Patent No. 11,735,810) filed March 25, 2022;
- U.S. Patent Application No. 18/339,523 (U.S. Patent No. 12,095,149) filed June 22, 2023;
- U.S. Patent Reexamination No. 90/019,275 filed October 12, 2023; and
- U.S. Patent Application No. 18/782,669 filed July 24, 2024.

## **2. United States Patent Trial and Appeal Board**

### **a. '200 patent**

The '200 patent was challenged in *Vivint, Inc. v. Fractus, S.A.*, IPR2024-00088, which settled and was terminated before Fractus filed a preliminary patent owner response and before institution decision. *Id.*, Paper 14 (Feb. 20, 2024).

### **b. Related patents**

U.S. Patent Nos. 11,031,677 is the subject of pending IPR2025-01026 ('677 patent), which Petitioners filed contemporaneously with this petition.

## **3. U.S. District Court for the Eastern District of Texas**

### **a. '200 patent**

The '200 patent is currently asserted in (i) *Fractus, S.A. v. Geotab Inc.*, No. 2:24-cv-01008 (E.D. Tex.) (“the Geotab Litigation”). The Geotab Litigation is consolidated with *Fractus, S.A. v. Verizon Connect Inc. et al.*, No. 2:24-cv-01009 (E.D. Tex.) (“the Verizon Litigation”).

The '200 patent was asserted in (i) *Fractus, S.A. v. ADT LLC*, No. 2:22-cv-00412 (E.D. Tex.) (“ADT Litigation”), which was dismissed with prejudice on October 4, 2024 (D.I. 253), and (ii) *Fractus, S.A. v. Vivint, Inc.*, No. 2:22-cv-00413 (E.D. Tex.) (“Vivint Litigation”), which was dismissed with prejudice on February 20, 2024 (D.I. 22).

**b. Related patents**

U.S. Patent Nos. 8,738,103 (a parent to the '200 patent) was asserted in both the ADT and Vivint Litigations.

The '677 patent and U.S. Patent No. 12,095,149 (which issued from, inter alia, a continuation of the '677 patent) are asserted in the Geotab and Verizon Litigations.

**C. Counsel and Service Information - §§42.8(b)(3) and (4)**

Lead Counsel	Adam R. Wichman, Reg. No. 43,988
Backup Counsel	Michael Parsons, Reg. No. 58,767 Shangxing (Simon) Lu, Reg. No. 80,263 Richard F. Giunta, Reg. No. 36,149
Service Information	<u>E-mail</u> : AWichman-PTAB@wolfgreenfield.com MParsons-PTAB@wolfgreenfield.com SLu-PTAB@wolfgreenfield.com RGiunta-PTAB@wolfgreenfield.com  <u>Post and hand delivery</u> : WOLF, GREENFIELD & SACKS, P.C. 600 Atlantic Avenue Boston, MA 02210-2206  <u>Telephone</u> : 617-646-8000 <u>Facsimile</u> : 617-646-8646

A power of attorney is submitted with the Petition. Counsel for Petitioners consents to service of all documents via electronic mail.

Geotab Inc. and Geotab USA, Inc. (“Geotab” or “Petitioners”) request *inter partes* review and cancellation of claims 1-20 (the “Challenged Claims”) of U.S. Patent No. 11,349,200 (EX1003, “the ’200 patent”).

## I. INTRODUCTION

The ’200 patent concerns antennas in wireless devices like mobile phones. The alleged “invention” purports to “provide antenna design parameters that tend to optimize the efficiency of” such antennas. EX1003, 5:21-26. The claims recite design parameters called “complexity factors”—a term coined by the inventors—that purport to characterize the “complexity” of an antenna’s three-dimensional shape.<sup>1</sup> According to the specification, an antenna designer should ensure that a designed antenna has “complexity factors” within certain ranges because that will ensure that the antenna is “optimized.”

Even if there were something inventive about this design methodology (which Petitioners do not concede), that is not what the ’200 patent claims. Instead, every claim concerns a wireless device with an antenna that meets the claimed complexity factors, regardless of whether a designer used those factors during an “antenna system” design process. The ’200 patent does not allege that

---

<sup>1</sup> The “complexity factors” are determined by mathematical calculation using a methodology described in the ’200 patent and explained in detail below.

the inventors were the first to ever design an antenna having “complexity factor” values that fall within the claims. They indisputably were not, as demonstrated by the antennas disclosed by Jing (Ground 1).

That the Examiner failed to appreciate that known antennas met the claimed complexity factors is unsurprising. Given that “complexity factor” was a term coined by the inventors, the Examiner could not have found any reference describing a prior art antenna’s “complexity factor” values. And as will become clear from the explanation below, applying the ’200 patent’s prescribed approach for calculating complexity factor values is a time-consuming process.

Compounding the problem, the applicant overwhelmed the Examiner with volume. The ’200 patent lists **1906** cited references. The record does not reflect that the Examiner calculated the complexity factor values for even a single prior art antenna. The claims issued without the Examiner rejecting a single claim.

The claims are demonstrably unpatentable. **Ground 1** shows that Dou (describing a wireless device with multiple antennas) implemented with Jing (describing a multiband antenna) renders obvious claims 1-15, 17, and 19-20.

Moreover, claims 1-20 are not entitled to an effective filing date before April 2014—the filing date of a **second** non-provisional application in the priority chain—because the **first** non-provisional application, filed in 2006, provides no written description supporting the full scope of an antenna operating at frequencies

and transmitting/receiving signals “*from*” or “*used by*” a “*4G communication standard*” genus. That makes Baliarda-543—the 2008 publication of the first non-provisional application—prior art. Baliarda-543’s disclosure comes *within* the challenged claim scope, even though it does not support *the full scope* of the claims. **Ground 2** shows that Baliarda-543 anticipates and/or renders obvious claims 1-20.

The Board should institute IPR and cancel claims 1-20.

**II. STANDING CERTIFICATION**

The ’200 patent is available for IPR. Petitioners are neither barred nor estopped from requesting IPR of the ’200 patent. 37 C.F.R. §42.104(a).

**III. UNPATENTABILITY GROUNDS**

Petitioners request cancellation of the following claims.

Ground	Reference(s)	Claims	Basis
1	Dou+Jing	1-15, 17, 19-20	§103
2	Baliarda-543	1-20	§§102/103

The AIA applies to *all* claims because, as explained *infra* §VII.A, the ’200 patent contains at least one claim that is not entitled to an effective filing date before March 16, 2013. AIA,<sup>2</sup> Pub. L. 112-29, §3(n)(1)(A), 125 Stat. 284, 293 (Sep. 16, 2011); Examination Guidelines, 78 Fed. Reg. 11059, 11083 (Feb. 14,

---

<sup>2</sup> Leahy-Smith America Invents Act.

2013) (“If there is ever even a single claim to a claimed invention in the application having an effective filing date on or after March 16, 2013, AIA [§§102, 103] apply in determining the patentability of every claimed invention in the application.”); MPEP §2159.02. But every reference used in Ground 1 is still prior art to the ’200 patent even if the AIA does not apply.

Each reference is prior art to the Challenged Claims as follows.

Reference	Priority Date	AIA	pre-AIA
Dou (EX1013)	2006-02-24	§102(a)(1)	§102(e)
Jing (EX1011)	2006-03-20	§102(a)(1)	§102(a)
Baliarda-543 (EX1040)	2008-01-24	§102(a)(1)	

Jing was included in *2005 Asia-Pacific Microwave Conference Proceedings*, volume 4, pp. 2657-2660, IEEE, 2005, published March 20, 2006 on IEEE Explore. EX1011, 2657-2660; EX1027, ¶¶6-8, 11-12, 15, p. 35; EX1014, ¶¶86-100. Jing is pre-AIA §102(a) prior art to every Challenged Claim because it was published before July 18, 2006 and before PO’s alleged conception on June 19, 2006. EX1011, Spine, Front Cover, Inside Front Cover, Library Stamped Page, 2657-2660; EX1014, ¶¶101-116.

In litigation, Patent Owner (“Fractus”) alleged that claims 1-4, 6-7, 9-13, 15, 17, and 19 were conceived by June 19, 2006. EX1016, 1-4. Even if every Challenged Claim was conceived by June 19, 2006 and entitled to the ’200 patent’s

earliest-alleged priority date (July 18, 2006), Dou and Jing are prior art under the foregoing pre-AIA §102 sub-sections. **Ground 1** shows that the Challenged Claims are unpatentable *regardless* of whether the AIA or pre-AIA law applies.

**Ground 2** shows that claims 1-20 are not entitled to priority before April 7, 2014. Under that analysis (*infra* §VII.A), Baliarda-543 (EX1040)—published before April 7, 2013—is AIA §102(a)(1) prior art.

#### IV. '200 PATENT<sup>3</sup>

The '200 patent concerns a “wireless device” with “smartphone functionality” and an “antenna system” “within” the device comprising a “ground plane” and “first” and “second” antennas. The multiband antennas are described as designed to send and receive electromagnetic signals in frequency ranges used by the frequency bands associated with various communication standards. EX1003, 5:30-41, 9:59-10:39, 12:34-36; 13:35-38 (“The resulting antenna structure... allow[s] the operation of the antenna system in multiple frequency bands.”), 25:14-30, 25:61-26:5.

The patent asserts that the antenna system’s design “is intended to use efficiently as much of the volume” within a defined space “in order to obtain superior RF performance... in at least one frequency band.” EX1003, 14:1-6. The

---

<sup>3</sup> All emphasis added unless otherwise indicated.

patent refers to the resulting antenna structure's "geometrical complexity" (EX1003, 14:10-20) and characterizes an antenna design's "level of complexity" in terms of "complexity factor"—which the specification defines as a mathematical calculation based on antenna dimensions using specific analytic steps, as explained *infra* §V.E (claim construction).

The patent asserts,

In accordance with embodiments of the invention, *the level of complexity of an antenna contour can be advantageously parameterized by means of two complexity factors*, hereinafter referred to as  $F_{21}$  and  $F_{32}$ , which capture and characterize certain aspects of the geometrical details of the antenna contour (such as for instance its edge-richness, angle-richness and/or discontinuity-richness) when viewed at different levels of scale.

EX1003, 16:64-17:4. The "[c]omplexity factor  $F_{21}$  is predominantly characterized by capturing the complexity and degree of convolution of features of the antenna contour that appear when the contour is viewed at coarser levels of scale," (EX1003, 19:26-29), whereas "[c]omplexity factor  $F_{32}$  is predominantly characterized by capturing the complexity and degree of convolution of features of the antenna contour that appear when the contour is viewed at finer levels of scale" (EX1003, 20:18-21).

The specification shows a single example antenna, e.g., an "antenna contour" reflecting a physical antenna layout (Figs. 12A, 17H), with a known

frequency response (Fig. 19A), evaluated for “complexity factor” (EX1003, 38:66-40:67).

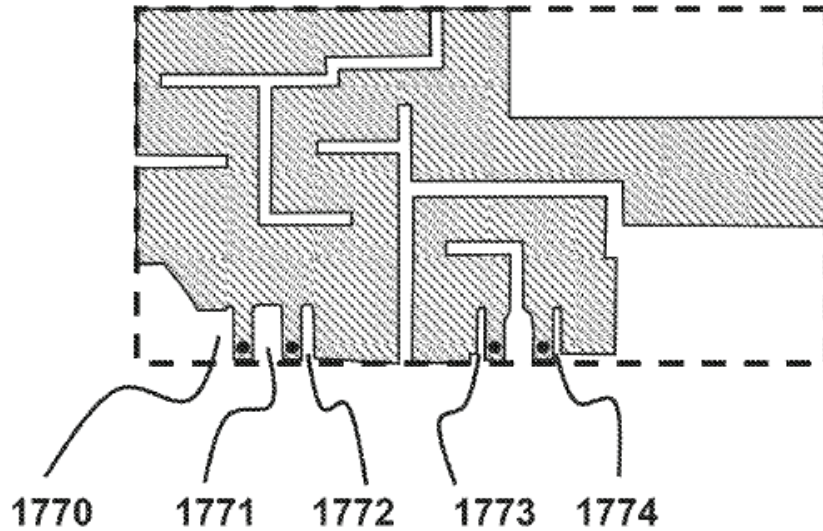


FIG. 17H

This antenna covers—meaning it can send and receive electromagnetic signals at—radio frequencies that are compatible with GSM and UMTS communication standards. EX1003, Fig. 19A, 38:66-39:46, 41:3-41:31. The operable frequency ranges are determined at a given voltage standing wave ratio (VSWR), a design parameter that measures how well the antenna works with the device electronics (e.g., transceiver) that send/receive electrical signals converted to RF radiation. EX1003, 2:3-5; EX1007 (“Weide”), ¶62.

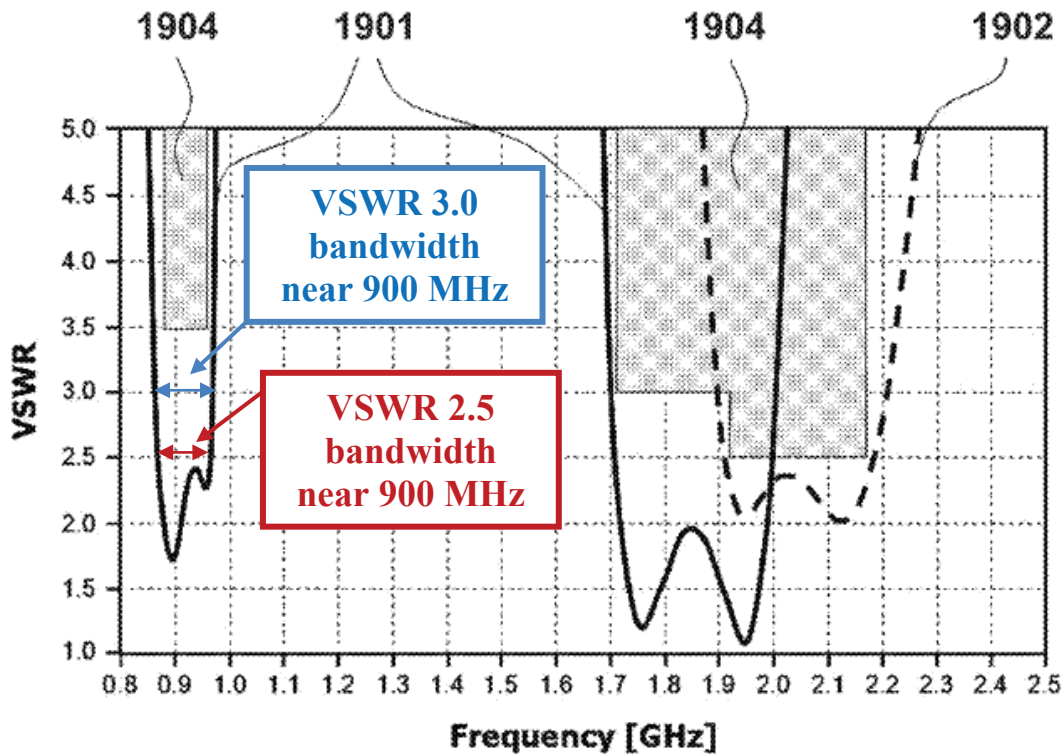


FIG. 19A

A *lower* VSWR means *a better match* between the antenna and the device electronics (e.g., transceiver), making the system more efficient at radiating energy: a perfect match has VSWR 1:1. Weide, ¶63. Figure 19A shows that lower VSWR is associated with a smaller frequency range, illustrating a well-known tradeoff between impedance match (e.g., VSWR) and antenna bandwidth. Weide, ¶63. The specification describes “maximum” VSWR values for frequency ranges associated with GSM and UMTS communication standards (EX1003, 37:22-52, Table 1), and Figure 19A shades regions with VSWR above the specification’s

“maximum” levels at different frequency ranges used with different communication standards. EX1003, 41:11-17; Weide, ¶63.

While the specification describes “complexity factors” for each step of “progressive modification” of an antenna contour from Figures 17A-17H (EX1003, 39:10-41:2, Table 2), the patent never shows the antenna performance—e.g., frequency response—associated with each “progressive modification” or that antenna’s “complexity factors.”

#### **A. POSA**

Petitioners adopt Fractus’s definition of a person having ordinary skill in the art (“POSA”) from the ADT Litigation:

[A] person with at least a bachelor’s degree in electrical engineering, computer science, or a similar degree and at least four years of experience in applied electromagnetics with an emphasis on antennas. Alternatively, the person of ordinary skill in the art would have a master’s degree in electrical engineering (or similar discipline) and at least two years of similar experience.

EX1018, 8-9, ¶32; Weide, ¶¶43, 40-55.

#### **B. Prosecution History**

The claims issued without substantive examination after Applicant filed a terminal disclaimer over U.S. Patent Nos. 8,738,103; 9,099,773; 9,899,727; 11,031,677; and 10,644,380. EX1004, 491-492. The Examiner allowed the claims

without rejection. EX1004, 499-510. In the Allowance, the Examiner stated that none of the considered references—Tran (US 6,989,794), Navsariwala (US 2005/0176390), Sabet (US 2002/0000944), Mikkola (US 2004/0145527), and Cohen (US 6,452,553)—disclose “*wherein the antenna contour has a level of complexity defined by complexity factor  $F_{21}$  having a value of at least 1.20 and complexity factor  $F_{32}$  having a value of at least 1.35.*”

*Ex parte* Reexamination Ser. No. 90/019,275 challenging claims 11-12 was declared January 10, 2024. EX1047, 246-249. The Examiner considered various combinations of U.S. Pub. No. 2004/0137950 (“Bolin”), GB2416625 (“Langley”), U.S. Pub. No. 2004/0051669 (“Rutfors”), and EP1294049 (“Ollikainen”). EX1047, 192-240. Fractus argued against combining Bolin and Langley because Langley’s antenna does not use a ground plane, and Bolin and Langley both provide Bluetooth antennas which would lead to interference. EX1047, 129-138. The Examiner agreed. EX1047, 12-14. The Examiner, however, did not take any position against including separate antennas covering the ISM 2.4 GHz band in which Bluetooth and WiFi both operate, e.g., as disclosed in Ollikainen (EX1029, [0044], Fig. 9).<sup>4</sup> A reexamination certificate issued October 18, 2024, confirming claims 11-12. EX1047, 1.

---

<sup>4</sup> EX1029 is unrelated to the Ollikainen used mentioned in the reexamination.

### C. Challenged Claims

The '200 patent has 20 claims, each concerning a “wireless device.” Appendix A provides a claim list. Claims 1, 6, and 11 are independent.

Claim 1 recites “*wireless device*” comprising an “*antenna system*” ([1.PRE]-[1.a]). The “*antenna system*” comprises “*a ground plane*” ([1.a]) and a “*first*” ([1.b]) and “*second antenna*” ([1.g]). The “*first antenna*” comprises a “*first antenna contour*” with “*complexity factor  $F_{21}$* ” being “*at least 1.20*” and “*complexity factor  $F_{32}$* ” being “*less than 1.35*” ([1.f]). Claims 6 and 11 recite additional limitations concerning first/second antenna frequency coverage, placement, or shape.

Dependent claims add further limitations concerning additional antennas and the shape, frequency coverage, and placement for the various antennas.

### V. CLAIM INTERPRETATION

Claim terms are construed using the standard for civil actions under 35 U.S.C. §282(b), in accordance with the ordinary and customary meaning as understood by POSAs and the patent’s prosecution history. 37 C.F.R. §42.100(b). The Board need only construe claims to the extent needed to resolve disputes between parties. *Nidec Motor Corp. v. Zhongshan Broad Ocean Motor Co.*, 868 F.3d 1013, 1017 (Fed. Cir. 2017). Various terms discussed below require

construction. Remaining terms should be given their ordinary meaning to a POSA and are met by the prior art in each Ground under any reasonable construction.

**A. “*perimeter*” (all claims)**

In the ADT Litigation, the court rejected Fractus’s proposed construction and construed “*perimeter*” as: “boundary of an object” ***excluding*** “any notion of ‘following the shape of the radiating element and extending it as necessary to complete the boundary’” as Fractus had urged. EX1020, 14-17; EX1021. The ADT Litigation was dismissed with prejudice. EX1023. That collaterally estops Fractus from arguing a different construction here. *Phil-Insul Corp. v. Airlite Plastics Co.*, 854 F.3d 1344, 1357-1358 (Fed. Cir. 2017). The court’s construction of “*perimeter*” comports with the ordinary meaning and the Board should apply it. Weide, ¶72.

**B. “antenna box” (claims 2, 6-20)**

The '200 patent says that Fig. 1B's element 103 shows an “antenna box,” stating:

An antenna box... *is herein defined* as being the minimum-sized parallelepiped of square or rectangular faces that completely encloses the antenna volume of space and wherein each one of the faces of the minimum-sized parallelepiped is tangent to at least one point of the volume. Moreover, each possible pair of faces of the minimum-size parallelepiped shares an edge forming an inner angle of 90°.

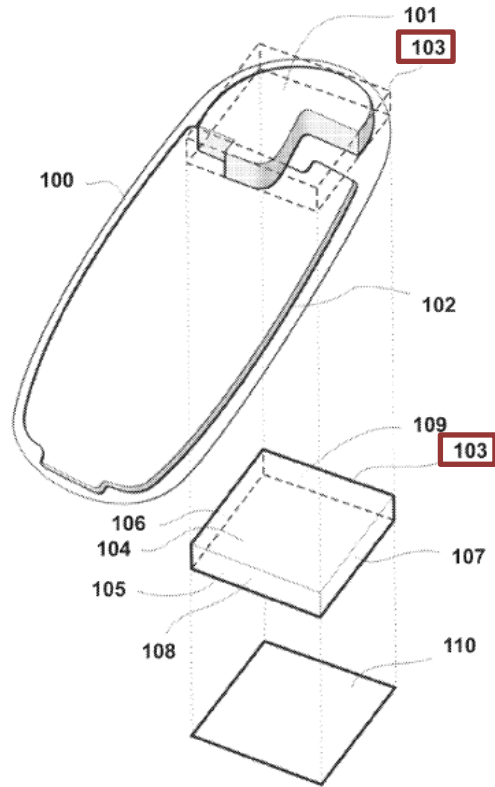


FIG. 1B

EX1003, Fig. 1B, 11:35-49.

The specification comports with “antenna box” as defined in [6.g], and defines “antenna box” as used in the claims. *Phillips v. AWH Corp.*, 415 F.3d 1303, 1316 (Fed. Cir. 2005) (en banc) (“specification may reveal a special definition given to a claim term” wherein “the inventor’s lexicography governs”).

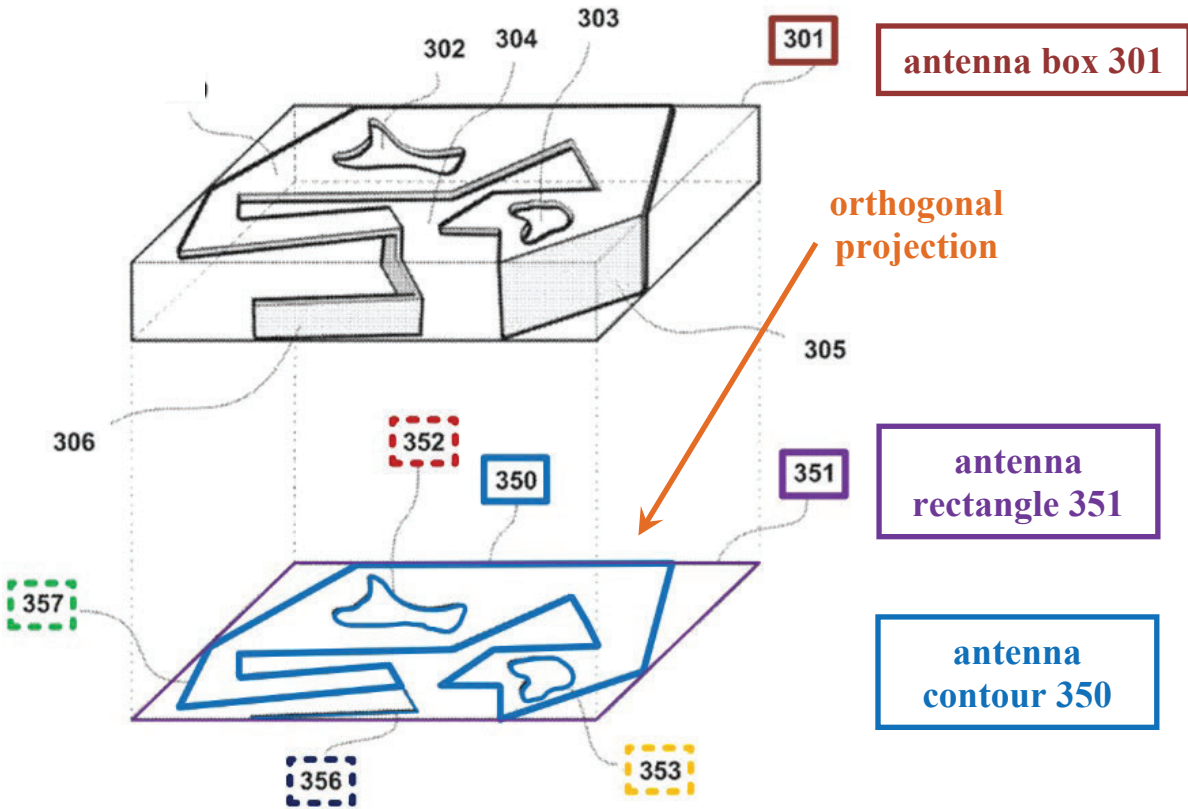
**C. “*antenna rectangle*” (claims 2-3, 6-20)**

The '200 patent states that “an antenna rectangle [] is obtained as the orthogonal projection of the antenna box [] along the normal to the face [of the antenna box] with largest area.” EX1003, 27:20-23; *Phillips*, 415 F.3d at 1316.

**D. “*antenna contour*” (all claims)**

The '200 patent says that Figure 3 shows an “*antenna contour*” 350 (blue outline below) for “antenna element 300” within “*antenna rectangle*” 351 (*supra* §V.C) formed from an orthogonal projection through “*antenna box*” 301 (*supra* §V.B). EX1003, Fig. 3 (annotated below), 27:20-23, 27:57-28:17.

The “*antenna contour*” 350 comprises “disjointed subsets of segments” from “*perimeter 357*” (*supra* §V.A), “segments 356 corresponding to the orthogonal projection of part 306,” and “segments” 352/353 “associated to the *perimeter* of aperture[s]” 302/303, respectively. EX1003, 27:62-28:17.



EX1003, Fig. 3 (annotated)

The '200 patent states, “[t]he antenna contour of the antenna system is a set of joined and/or disjointed segments comprising” (with numbering added):

[1] *the perimeter* of one or more antenna elements *placed in the antenna rectangle*,

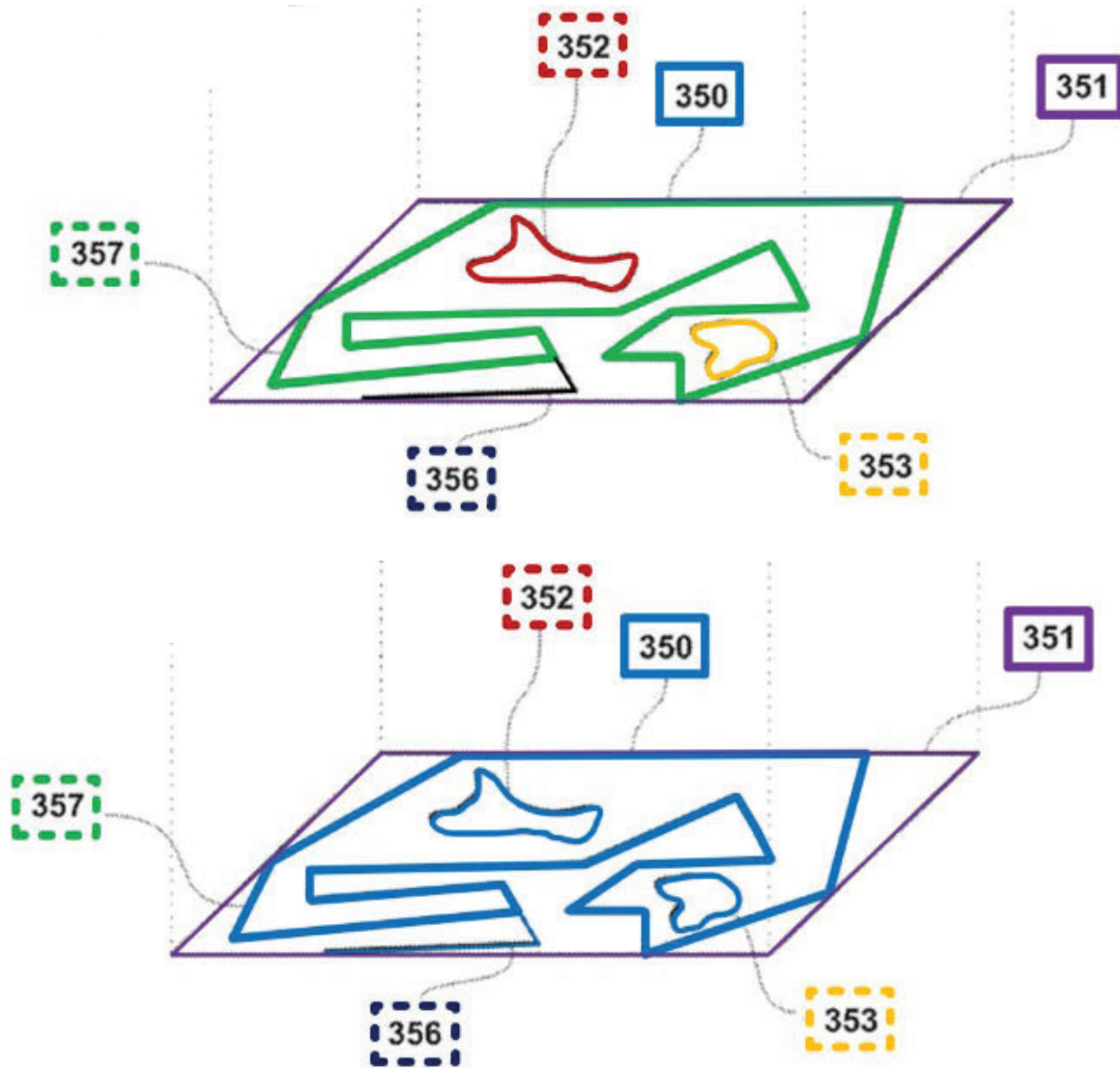
[2] *the perimeter* of closed slots and/or closed apertures defined within the antenna elements, and/or [3] the *orthogonal projection onto the antenna rectangle* of *perimeters* of antenna elements, or *perimeters* of or parts of antenna elements that are *placed in the antenna box* but not in *the antenna rectangle*.

EX1003, 15:16-37 (“Not all the segments that form the antenna contour need to be connected (i.e., to be joined). In some cases, the antenna contour comprises two,

three, four or more disjointed subsets of segments.”); *Phillips*, 415 F.3d at 1316.

Figure 3 shows antenna contour 350 comprising each disjointed subset: [1] *perimeter* 357 and projection 356, [2] *perimeter* 352, and [3] *perimeter* 353.

EX1003, Fig. 3 (annotated detail below).



**E. “complexity factor,” “ $F_{21}$ ,” “ $F_{32}$ ” (all claims)**

Every claim recites a “complexity factor,” which the ’200 patent says is a number that characterizes an “antenna contour.” EX1003, 16:64-17:4; *supra* §V.D.

The “*complexity factors*,” “ $F_{21}$ ” and “ $F_{32}$ ,” have no ordinary meaning in the art. Weide, ¶79. The ’200 patent specification defines these factors as the numerical result of a calculation based on operations involving overlaying a series of three specifically-formulated grids ( $G_1$ ,  $G_2$ , and  $G_3$ , respectively) on the “*antenna rectangle*”—thereby overlaying an “*antenna contour*”—as explained below. EX1003, 17:5-15; *Phillips*, 415 F.3d at 1316.

## 1. Grids

The ’200 patent states that “[g]rids  $G_1$  and  $G_3$  are constructed from grid  $G_2$ [.]” EX1003, 17:26-27. The choice of the second grid dimensions (rows and columns) thus determines the first and third grid dimensions as shown below.

### a. Second Grid $G_2$

The second grid  $G_2$  cell size and aspect ratio—“the ratio between [cell] width and... height”—are chosen to “perfectly tessellate[.]” the “*antenna rectangle*” with “an odd number of columns and an odd number of rows.” EX1003, 17:28-32. The specification associates the *antenna rectangle*’s long side (i.e., “width”) with grid *columns* and the short side (i.e., “height”) with grid *rows*. EX1003, 17:33-56.

Each grid has “substantially square or rectangular cells” (EX1003, 17:5-15), wherein if “two different combinations of a number of columns and a number of rows of cells of the second grid produce a cell as square as possible, a second grid is selected such that the aspect ratio”—the ratio of cell width to cell height—“is

larger than 1.” EX1003, 17:65-18:7. The closer the cell’s aspect ratio is to 1 (e.g., wherein the height and width of the cell are the same), the closer the cell is to square.

The ’200 patent says Figure 14B shows a “second grid” 1402 “tessellat[ing]” antenna rectangle 1400 with 9 columns and 5 rows. EX1003, Fig. 14B (annotated below), 34:53-67, 35:7-11.

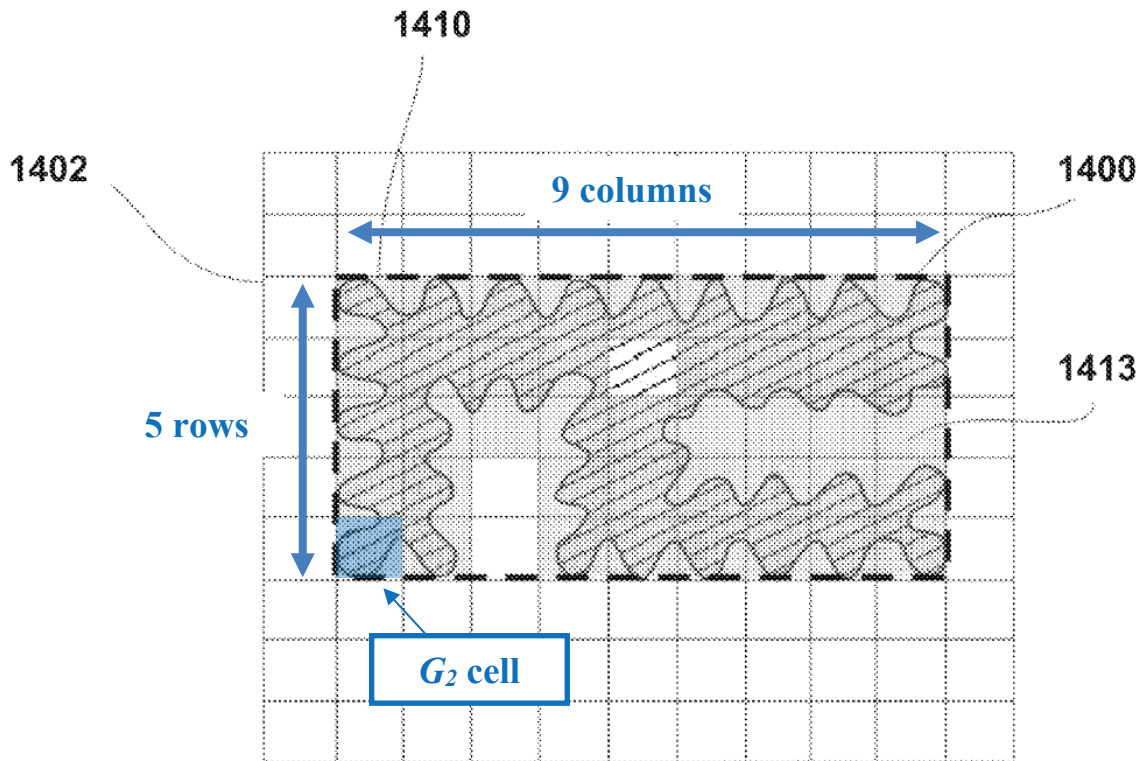


FIG. 14B

**b. First Grid  $G_1$**

The ’200 patent states that “[a] first cell of the grid  $G_1$  is... created by grouping four cells of grid  $G_2$  in such a manner that a corner of the first cell is the

feeding point corner, and the first cell is positioned completely inside the antenna rectangle.” EX1003, 18:66-19:2.

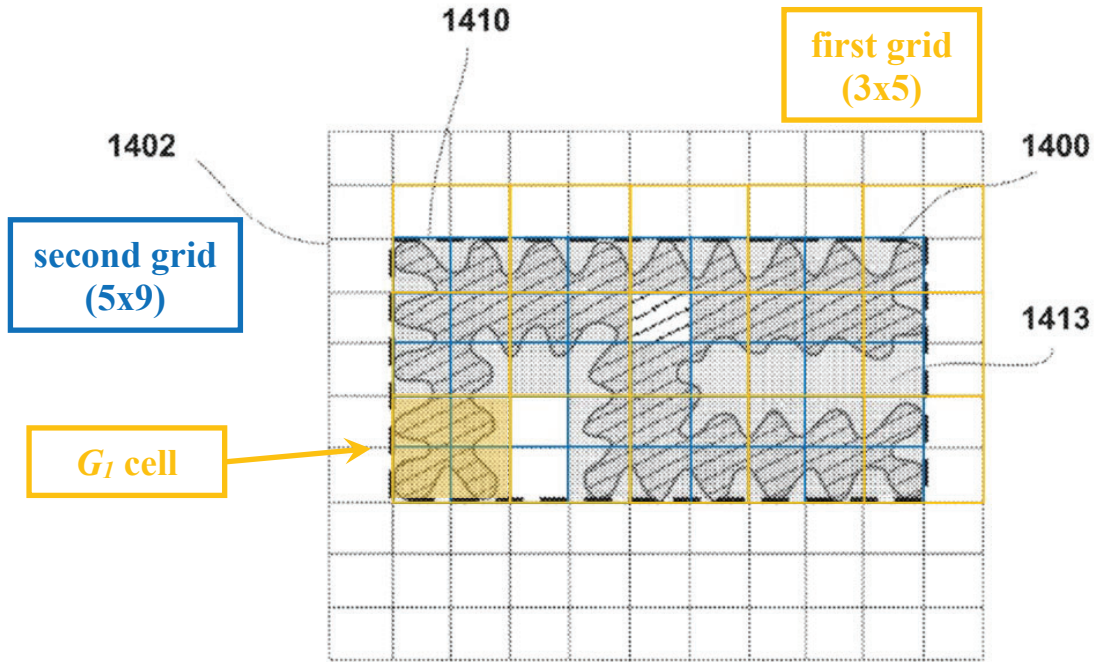
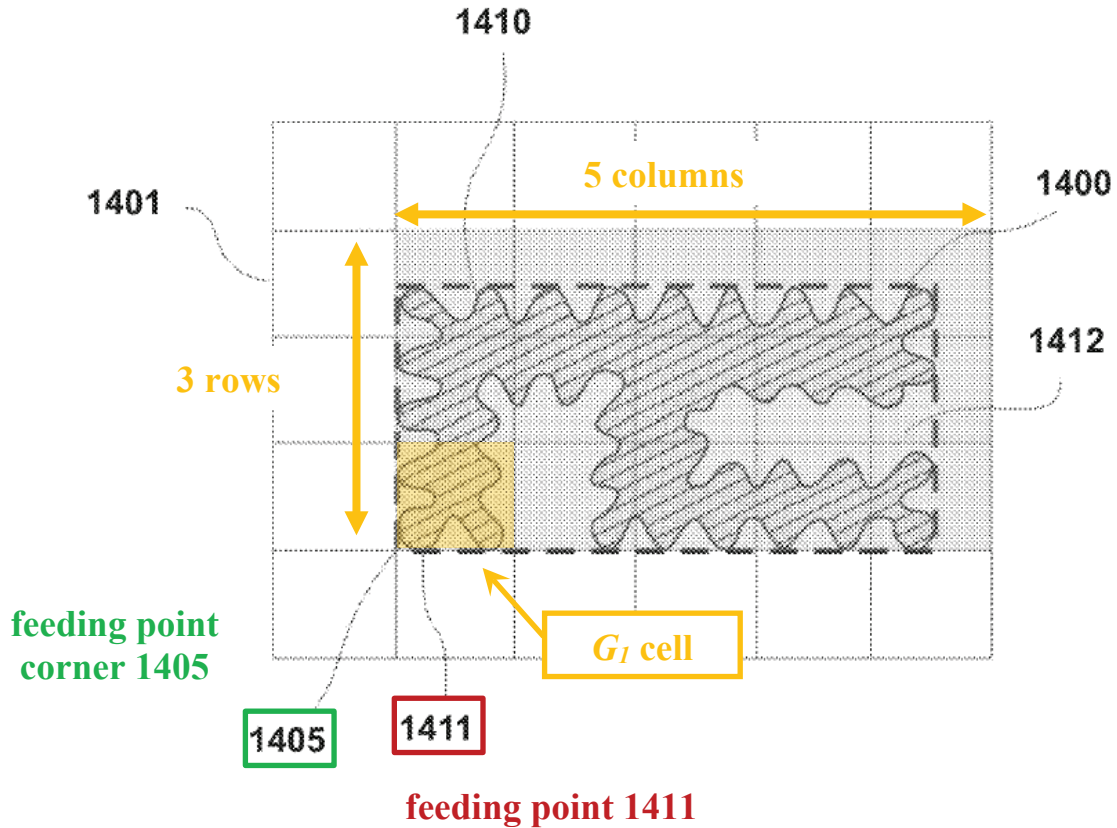


FIG. 14B



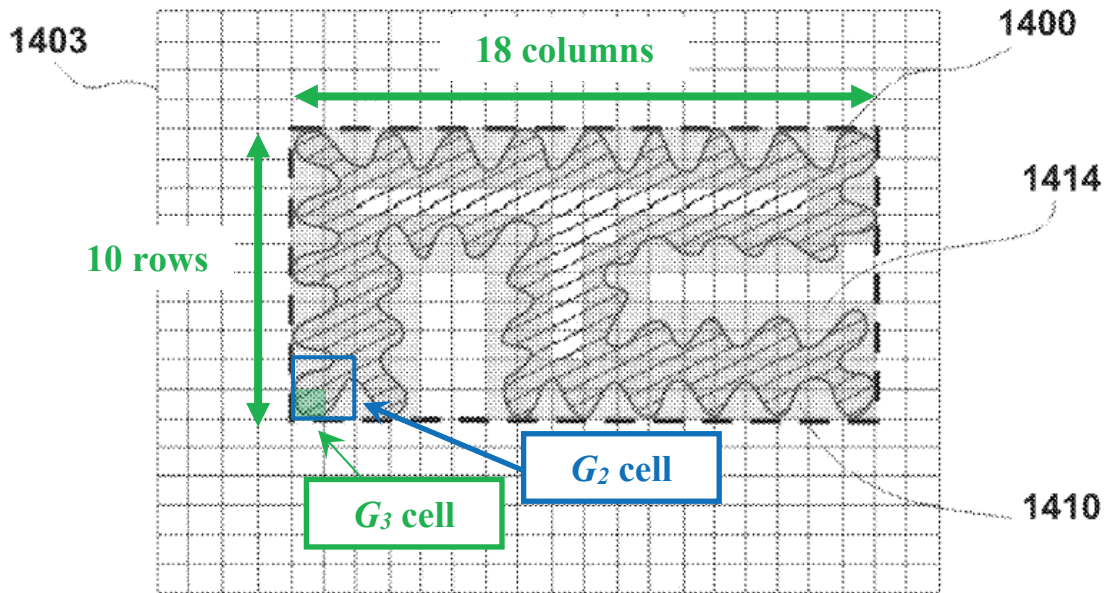
As shown below, the relevant cells of a first grid are the minimum set of cells all of the same size as the first cell and encompass the entire antenna contour.



The '200 patent says that Figure 14A shows a first grid 1401, with “feeding point 1411, located substantially close to the bottom left corner of the antenna rectangle 1405 (being thus the feeding point corner).” EX1003, Fig. 14A (annotated above), 34:53-67.

**c. Third Grid  $G_3$**

The third grid ( $G_3$ ) fits twice as many rows and columns within the *antenna rectangle* as the second grid ( $G_2$ ), thereby replacing “each cell of... grid  $G_2$ ... with 2-by-2 cells of... grid  $G_3$ [.]” EX1003, 19:62-20:4. Each third grid’s cell has width ( $W_3$ ) that is half the second grid cell width, and height ( $H_3$ ) that is half the second grid cell height. *Id.* The ’200 patent states that Figure 14C shows third grid 1403 formed from second grid 1402. EX1003, Figs. 14B, 14C, 34:53-56, 35:12-17.



**FIG. 14C**

**2. Calculation**

The claims recite two “complexity factors” named “ $F_{21}$ ” and “ $F_{32}$ .” The ’200 patent defines each “complexity factor” as follows.

a. “ $F_{21}$ ”

“The complexity factor  $F_{21}$  is computed by”:

- [1] counting the number of cells  $N_1$  in grid  $G_1$  that [a] “are at least partially inside the antenna rectangle” and [b] “include at least a point of the antenna contour”; and
- [2] counting the number of cells  $N_2$  in grid  $G_2$  that [a] “are completely inside the antenna rectangle” and [b] “include at least a point of the antenna contour[.]”

EX1003, 19:12-20. The ’200 patent states “in the present invention the boundary of the cell is also part of the cell[.]” EX1003, 19:16-17.

“The complexity factor  $F_{21}$  is computed by... then applying the following formula:”

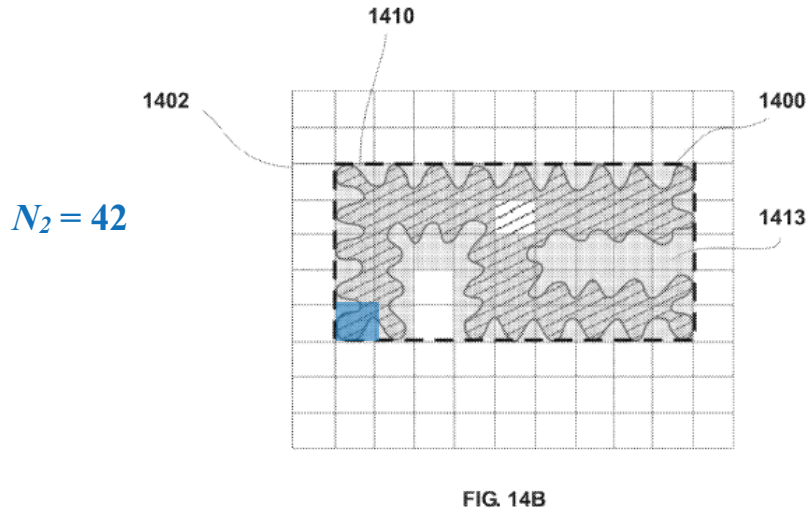
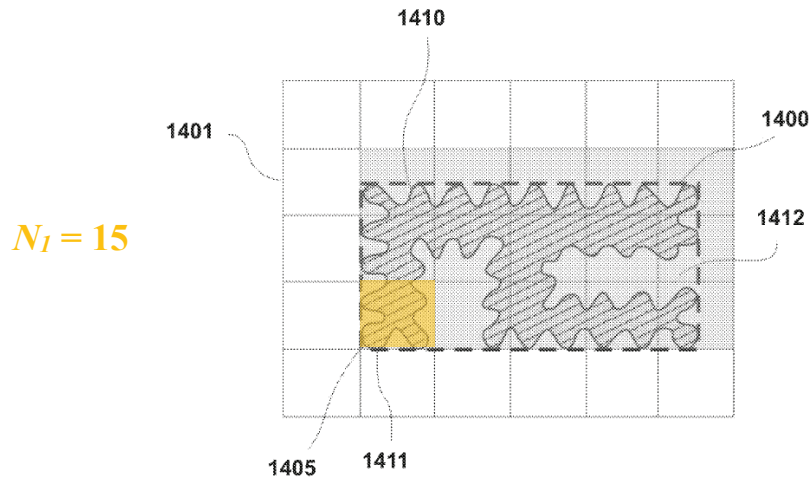
$$F_{21} = -\frac{\log(N_2) - \log(N_1)}{\log(1/2)}$$

EX1003, 19:12-25; *Phillips*, 415 F.3d at 1316; *Weide*, ¶¶90-95.

Using Figure 14’s *antenna contour* 1410, the patent describes:

- a **first grid** (Fig. 14A, 1401) with  $N_1$ =“fifteen (15) cells,” shown as shaded group 1412, meeting [1][a]-[b] above; and
- a **second grid** (Fig. 14B, 1402): with  $N_2$ =“forty-two (42) cells,” shown as shaded group 1413, meeting [2][a]-[b] above. Within *antenna rectangle* 1400, unshaded cells do not meet the requirement to [2][b] “include at least a point of the antenna contour[.]”

EX1003, Figs. 14A-14B, 35:1-11; Weide, ¶96



The complexity factor  $F_{21}$  for antenna contour 1410 is thus:

$$\begin{aligned}
 F_{21} &= -\left(\frac{\log(N_2) - \log(N_1)}{\log(1/2)}\right) = -\left(\frac{\log(42) - \log(15)}{(-1)\log(2)}\right) \\
 &= \left(\frac{\log(42/15)}{\log(2)}\right) = \left(\frac{0.447}{0.301}\right) = 1.49.
 \end{aligned}$$

EX1003, 35:18-24; Weide, ¶¶97-98.

b. “ $F_{32}$ ”

“The complexity factor  $F_{32}$  is computed by” [3] counting the number of cells  $N_3$  in grid  $G_3$  that [a] “are completely inside the antenna rectangle” and [b] “include at least a point of the antenna contour,” EX1003, 20:5-11, “and then applying the following formula:”

$$F_{32} = -\frac{\log(N_3) - \log(N_2)}{\log(1/2)}$$

EX1003, 20:12-16; Weide, ¶99.

Using Figure 14’s *antenna contour* 1410, the patent describes a **third grid** (Fig. 14C, 1403) with  $N_3$ =“one hundred and forty-two (142) cells,” shown as shaded group 1414, meeting [3][a]-[b]. EX1003, Figs. 14B-14C, 35:12-17; Weide, ¶100. Unshaded cells in Figure 14C do not meet the  $G_3$  cell counting criteria.

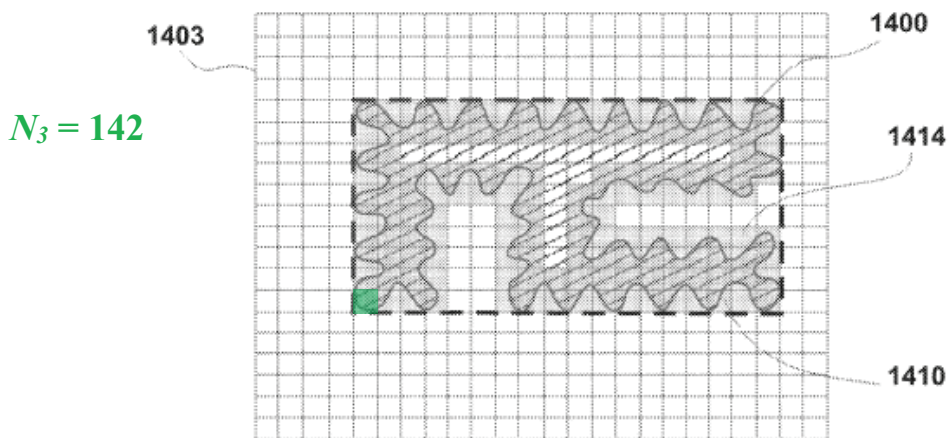


FIG. 14C

Using the  $N_2 = 42$  result for Figure 14B, the *complexity factor*  $F_{32}$  for *antenna contour* 1400 is thus:

$$\begin{aligned} F_{32} &= -\left(\frac{\log(N_3) - \log(N_2)}{\log(1/2)}\right) = -\left(\frac{\log(142) - \log(42)}{(-1)\log(2)}\right) \\ &= \left(\frac{\log(142/42)}{\log(2)}\right) = \left(\frac{0.529}{0.301}\right) = 1.76. \end{aligned}$$

EX1003, 35:25-30; *Phillips*, 415 F.3d at 1316; Weide, ¶101.

### 3. Fractus’s ADT Litigation argument

In the ADT Litigation, Fractus argued that the ’200 patent “explain[s] precisely how to calculate the complexity factors F21 and F32[.]” EX1017, 24. Fractus’s ADT Litigation construction concedes that the specification defines “*complexity factor*” and comports with the analysis *supra* §§V.E.1-V.E.2 applying the specification’s instructions. Weide, ¶102.

#### F. “*wireless device*” (all claims)

In the ADT Litigation, Fractus argued (and the court agreed) that “the ordinary meaning of ‘wireless device’... refers to the nature of the communication,” e.g., that the device can communicate wirelessly. EX1020, 11. The Board should apply that construction here.

#### G. “*4G communication standard*” terms (all claims)

The claims require antennas capable of operating with a “*4G communication standard*” (claims 1-20): an “*antenna... configured to transmit and receive signals*

*from a 4G communication standard*” (claims 1-5); an “*antenna configured operate in... [a] frequency band being used by a 4G communication standard*” (claims 6-10); and an “*antenna configured to provide operation in... frequency bands being used by 4G communication standards*” (claims 6-20).

As shown below (*infra* §V.G.2) Fractus’s litigation arguments take the position that “*4G communication standard*” is met by LTE; an LTE frequency band is “*used by*” a “*4G communication standard*”; and an “*antenna configured to... receive signals from a 4G communication standard*” is met by an antenna covering LTE frequency bands. Weide, ¶105. The prior art in Ground 1 meets these “*4G*” terms under Fractus’s arguments, so that there is no dispute over the meaning of the “*4G*” terms that requires the Board’s resolution in order to decide Ground 1. *10X Genomics v. Bio-Rad Labs.*, IPR2020-00086, Paper 8, 17-19 (April 27, 2020) (claim constructions based on patent owner’s infringement contentions comply with 37 C.F.R. §42.104(b)(3)); *Nidec*, 868 F.3d at 1017.

Ground 2 shows that the full scope of the genus “*4G communication standard*” is unsupported by the written description in the priority documents. Weide, ¶106. This issue can also be decided under Fractus’s litigation arguments, so that there is no dispute over the meaning of the “*4G*” terms that requires the Board’s resolution to decide Ground 2. *Nidec*, 868 F.3d at 1017.

Regardless, the relevant evidence on the meaning of the “4G” terms is explained below.

### 1. Intrinsic evidence

The written description never uses the term “*4G communication standard*.” The ’200 specification equates “4G standards” with “4G services” providing “4G features”:

A MFWD incorporating 3.5G or *4G features* (i.e., comprising 3G and other advanced services such as for instance HSDPA, WiBro, WiFi, WiMAX, UWB or other high-speed wireless standards, *hereinafter 4G services*) might require operation in additional frequency bands corresponding to *said 4G standards*[.]

EX1003, 25:15-20. The antecedent for “said 4G standards” (EX1003, 25:20) is “4G services,” and the “frequency bands corresponding to said 4G standards” comprise “frequency bands of the 4G services[.]” EX1003, 25:15-30. The patent defines a “4G antenna” as an “antenna covering one or more of the 4G services[.]” EX1003, 25:36-38; *Phillips*, 415 F.3d at 1316.

Thus, “*4G communication standard*” is met by a “wireless standard” for “4G services” and “*antenna... configured to... receive signals from a 4G communication standard*” is met by an antenna that is operable in a frequency range used by a “4G service,” where the “i.e.” signal means that the patent defines a “4G service” as “comprising 3G and other advanced services such as for instance

HSDPA, WiBro, WiFi, WiMAX, UWB or other high-speed wireless standards[.]”  
EX1003, 25:15-20; *Phillips*, 415 F.3d at 1316.

## 2. Fractus’s Litigation Arguments

In the ADT Litigation, Fractus argued that “antenna functions” for “4G communication standard” meant antenna “compatibility with HSDPA, WiFi, WiMax, WiBro, UWB, or other highspeed wireless standards” further including “second-generation (2G) mobile, IMT-2000, [and] wireless local area network (WLAN)” (EX1017, 19-20) while “communication standard” meant “technical specifications relating to mobile or radio communication systems, including but not limited to GSM, UMTS, CDMA, W-CDMA, and LTE.” EX1017, 20 n.9; EX1018, 10, ¶36. Fractus also argued that “receive signals from a 4G communication standard” meant “the antenna could interact with a signal sent by a Fourth generation cellular technology to obtain or receive electromagnetic energy.” EX1017, 18 n.8 (cleaned up); EX1018, 10, ¶37.

In the Geotab Litigation, Fractus maps “a 4G communication standard” to LTE bands 2, 4, 5, and 12. EX1024, 21 (’677 patent), 27 (’200 patent, excerpt below); *see also* EX1049, 4-5, 9, 20; EX1050, 4-5, 9, 20; EX1051, 4; EX1052, 3-4, 8, 19-20, 24; EX1053, 4; EX1054, 4; EX1055, 4; EX1056, 3-4, 8, 18; EX1057, 4, 9, 16-17, 21, 31; EX1058, 4-5, 9, 20; EX1059, 3-4, 8, 19-20, 24.

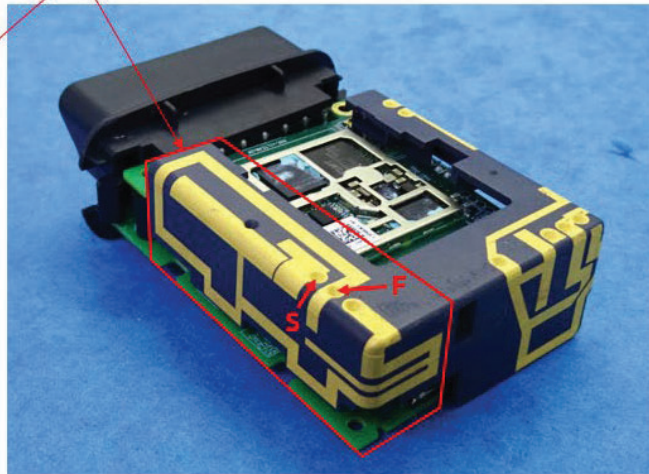
[11d] The antenna system comprises a first antenna (indicated in red) configured to provide operation in at least LTE 700(B12)/1700-2100(B4)/1900(B2)

Regulatory Band:

❖ Cellular:

- LTE Band 2 : 1850 ~ 1910 MHz
- LTE Band 4 : 1710 ~ 1755 MHz
- LTE Band 5 : 824.0 ~ 849 MHz
- LTE Band 12 : 699 ~ 716 MHz

Source: FCC RF Exposure evaluation report



EX1024, 27.

Thus, Fractus takes the litigation position that “4G communication standard” is met by LTE. This comports with LTE, which was “an evolution of 3G into an evolved radio access,” meeting the ordinary meaning of “4G communication standard.” EX1039, 3, 21-25; Weide, ¶¶112-113. LTE is a “fourth generation cellular technology” so that an antenna that can send/receive signals using LTE meets Fractus’s construction of “receive signals from a 4G communication standard” as “the antenna could interact with a signal sent by a Fourth generation cellular technology to obtain or receive electromagnetic energy.” EX1017, 18 n.8; Weide, ¶113.

**VI. GROUND 1: DOU+JING RENDERS OBVIOUS CLAIMS 1-15, 17, AND 19-20**

**A. Dou (EX1013)**

Dou describes wireless devices, e.g., handheld computers, mobile telephones, etc., with internal diversity antenna architectures having three or more antennas including a first antenna located substantially near the top, and a second antenna located substantially near the bottom, of a device housing and/or internal PCB. Dou, Abstract, Figs. 2A, 3A, [0015], [0017], [0032], [0040]; Weide, ¶¶114-115.

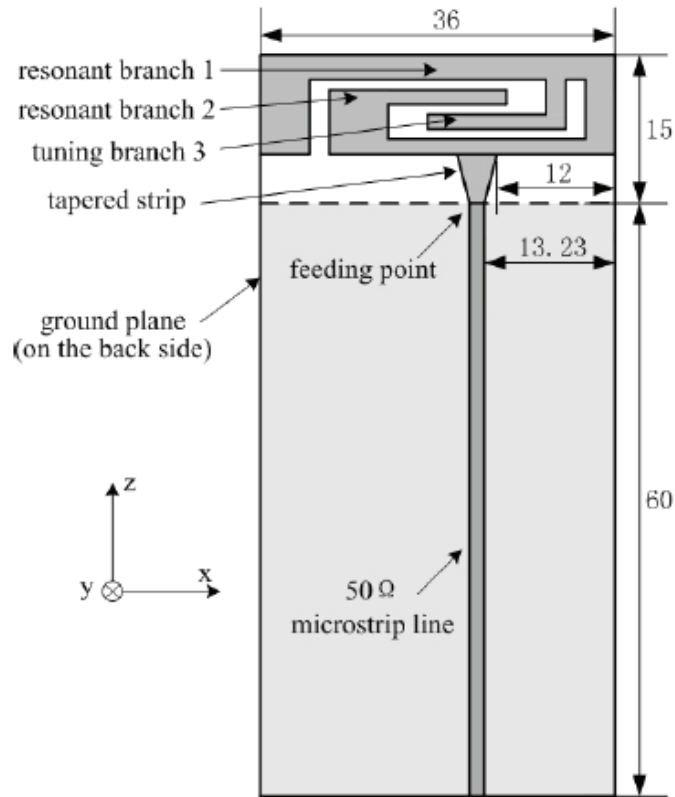
Dou's antennas operate at multiple frequency ranges associated with different communication services, e.g., GSM, PCS, WCDMA/UMTS, GPS, NAMPS, "WiFi," and Bluetooth. Dou, [0022]. The antennas "may be... any type of suitable internal antenna" (Dou, [0028]) of different types. *E.g.*, Dou, [0034], [0040]; Weide, ¶116.

**B. Jing (EX1011)**

Jing teaches a compact multiband "planar monopole antenna with a 2-dimensional structure" for mobile handsets that operates with DCS, PCS, UMTS, and WLAN services. Jing, 2657, 2660, Fig. 1(a) (below).<sup>5</sup>

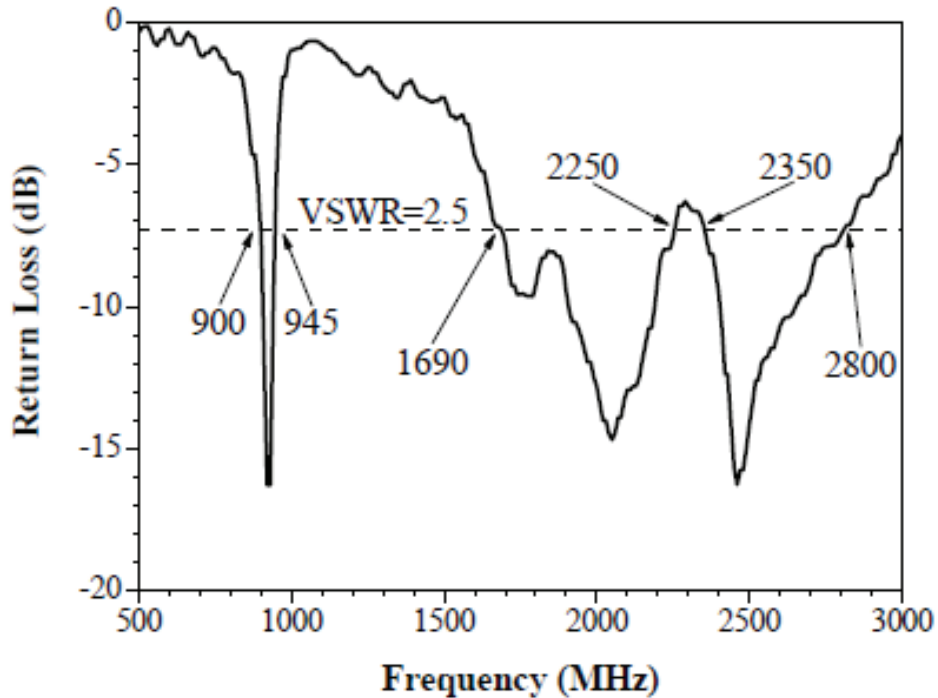
---

<sup>5</sup> The Petition uses figures from Jing's more legible online version (EX1014, Att. C-1), which is materially identical to EX1011.



(a)

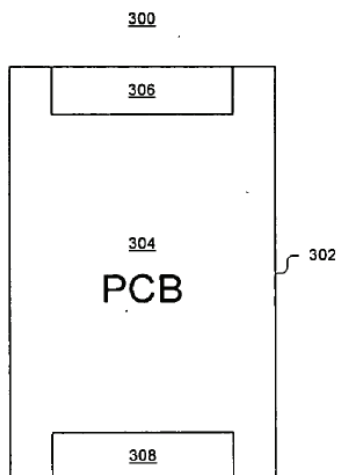
When matched to suitable electronics (e.g., a transceiver) at VSWR (voltage standing wave ratio) of 2.5:1, Jing's antenna operates at 900-945 MHz, 1690-2250 MHz, and 2350-2800 MHz. Jing, Fig. 3 (measured return loss below), 2657-2658; Weide, ¶118-121.



### C. Dou+Jing

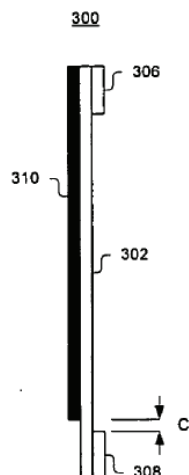
While Dou describes a wireless device having internally-mounted antennas, it does not describe particular antennas for achieving its wireless devices. Instead, Dou leaves antenna selection to a POSA. Weide, ¶122.

A POSA would have had reasons to use a Jing antenna for each of Dou’s first and second antenna. Jing’s antenna was designed for internal use in mobile handsets, making it suitable for use as Dou’s “internal antenna[s]” 306 and 308 “integrated with the wireless device.” Dou, [0033], Figs. 3A-3B (below); Jing, 2657, Fig. 1(a) (below); Weide, ¶123.

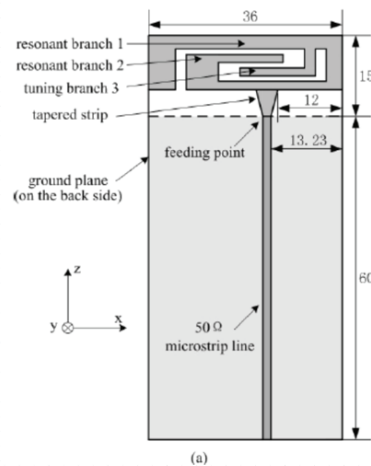


**FIG. 3A**

Dou



**FIG. 3B**



(a)

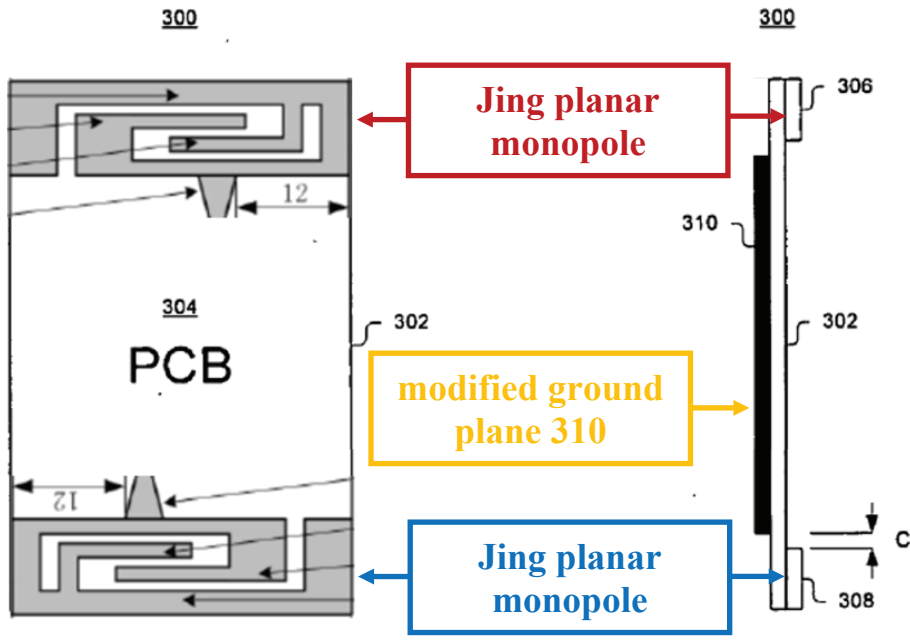
Jing

Jing’s antenna is a “planar monopole antenna” (Jing, 2657 (Abstract)), which Dou describes using for the first/second antennas. Dou, [0034]. Jing’s antenna provided operation at frequencies used by well-known communication standards (DCS, PCS, UMTS, Zigbee, WiFi) making it “suitable for mobile phone applications” like Dou’s device. *Supra* §VI.B (Jing); Jing, 2658, Fig. 3; Dou, [0022] (describing exemplary coverage for PCS, “WCDMA/UMTS,” and “WiFi and Bluetooth”);<sup>6</sup> Weide, ¶124.

<sup>6</sup> WiFi is a certification that a system is compatible with WLAN communications. EX1003, 10:27 (WiFi uses IEEE Std. 802.11); EX1060, 1-2 (showing WiFi is a trademark of the Wi-Fi Alliance that certifies “interoperability of IEEE 802.11 products”); Weide, ¶125.

POSAs would have used Jing as Dou's antennas 306 and 308. Weide, ¶126. Dou's PCB 302 has ground plane 310 on the back, just like Jing has a "system ground plane" on the back surface of an FR4 substrate. Dou, Fig. 3B, [0034]; Jing, Fig. 1(a), 2658; Weide, ¶126. POSAs would have recognized that whether the ground plane extends under Dou's antennas depends on the specifications required by the implemented antennas. Weide, ¶126. Dou places antenna 308 at "no less than 5 mm" offset from ground plane 310 just like Jing places its antenna with a 5 mm taper offsetting it from its ground plane. Dou, Fig. 3B, [0034]; Jing, Fig. 1(a), 2657-2658; Weide, ¶126.

POSAs would have implemented Dou's antenna 306 using Jing's antenna to achieve Dou's diversity architecture. Dou, [0034] (explaining embodiments not limited to depiction in Fig. 3); Weide, ¶127. As shown in modified Dou Figs. 3A-3B (below), a POSA would have used Jing's teachings to modify Dou's ground plane to replicate Jing's ground plane dimensions of  $36 \times 60 \text{ mm}^2$ , and limited the extent of Dou's ground plane 310 so that it did not extend behind Jing's antenna at 306, just like Dou does not extend it behind antenna 308. Jing, 2657-2658, Fig. 1(a); Weide, ¶128.



**FIG. 3A**

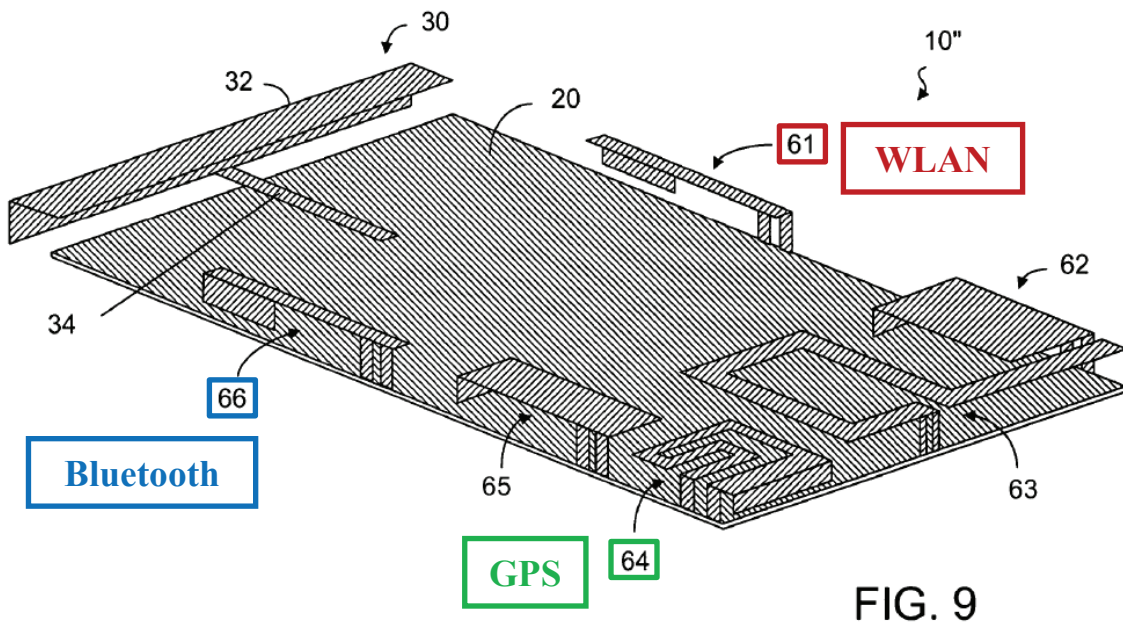
**FIG. 3B**

**Dou implemented with Jing**

Dou’s wireless device may include “three or more antennas... compris[ing] any suitable type of internal antenna” (Dou, [0040]), and describes the wireless device having a separate antennas covering GPS (1575 MHz) and Bluetooth. Dou, [0022]. A POSA would have had reasons to include a GPS antenna to provide the GPS wireless services that Dou describes, in frequency ranges (1575 MHz) not covered by Jing’s antenna. EX1048, 2 (GPS performance standard); Weide, ¶¶129-130.

While Jing’s antenna covers the 2.4 GHz ISM band at 2400-2500 MHz, it was conventional to include multiple antennas in a single mobile device to support

dedicated communications using different services like WiFi (e.g., WLAN) and Bluetooth that used the same frequency range (e.g., the 2.4 GHz ISM band). For example, EX1029 describes a mobile device having *seven* antennas, including separate GPS antenna 64, WLAN antenna 61, and Bluetooth antenna 66. EX1029, Fig. 9 (below), [0044]; Weide, ¶131. Providing separate antennas for WLAN and Bluetooth—even if they used the same 2.4 GHz ISM band—simplified the electronics supporting those services and eliminated the need for switching or multiplexing access to a single antenna. Weide, ¶131.



Implementing Dou’s antennas 306, 308 using Jing (hereinafter “Dou+Jing”) would have combined familiar elements according to known methods with predictable results, *KSR Int’l v. Teleflex*, 550 U.S. 398, 416 (2007), and been no more than the “predictable use of prior art elements according to their established

functions.” *Id.*, 417. The same is true of adding a GPS and Bluetooth antenna to Dou’s device to provide additional services that Dou describes. Weide, ¶132.

POSAs would have reasonably expected success using Jing’s antenna in Dou’s device because Jing designed its antenna for internal use in mobile handsets (Jing, 2657), and Dou expressly contemplates using multiband antennas—like Jing’s—as its first/second internal antenna (e.g., Dou, [0028]-[0029], [0034]). Weide, ¶133. Dou describes antenna placement within the device according to “various performance and design constraints” known to POSAs. Dou, [0030]; Weide, ¶133. Jing describes placing its antenna at the end of a PCB, just like Dou. Jing, Fig. 1(a), 2657; Dou, Figs. 3A-3B, [0031]-[0032]; Weide, ¶133. It was well within the POSA’s ordinary skill to implement Dou’s device with Jing’s antenna, and the resulting antenna operation was predictable. Dou, [0012], [0063]; Weide, ¶133.

POSAs would have reasonably expected success including a GPS and a Bluetooth antenna in Dou’s wireless device because this was conventional (EX1029, [0044]), Dou explains that “the antenna architecture may comprise three or more antennas” (Dou, [0040]), and Dou specifically describes the wireless device having GPS and Bluetooth coverage. Weide, ¶134.

A POSA would have understood that a co-located dedicated Bluetooth antenna was compatible—and would not have interfered—with Jing’s WLAN

operation in the 2.4 GHz ISM band because—as EX1029 confirms—mobile devices conventionally used separate Bluetooth and WLAN antennas, and because the two services used different transmission techniques that minimized mutual interference. Weide, ¶135. Bluetooth uses frequency hopping, which minimizes signal energy at a single frequency. EX1044, 27 (“A frequency hop transceiver is applied to combat interference and fading.”), 69 (physical channel characterized by pseudo-random frequency hopping sequence), 75 (adaptive frequency hopping); Weide, ¶135. A WLAN (e.g., IEEE Std. 802.11b) system senses whether a channel is busy (e.g., in use) before transmitting, which prevents interference from simultaneous transmission on a channel (e.g., a discrete frequency range). EX1043, 58 (describing carrier sense and energy detection indicating a busy channel); Weide, ¶135.

The combination (“Dou+Jing”) thus had at least *four* antennas: two Jing antennas, a GPS antenna, and a Bluetooth antenna, and renders obvious claims 1-15, 17, and 19-20 as shown below. Weide, ¶136.

## D. Analysis

### 1. Claim 1

#### a. Preamble

[1.PRE]	A wireless device comprising:
---------	-------------------------------

Dou+Jing meets [1.PRE] because Dou describes a wireless device comprising, *e.g.*, a handheld computer, mobile telephone, or PDA. Dou, [0015]-[0016], [0031], claim 1; Weide, ¶137.

#### b. Element [1.a]

[1.a]	an antenna system comprising a ground plane and at least two antennas within the wireless device, the antenna system comprising:
-------	--

Dou+Jing meets “*an antenna system comprising ... at least two antennas within the wireless device*” because Dou’s device 300 has “an internal diversity antenna architecture comprising a first internal antenna 306 and a second internal antenna 308 disposed on the PCB 304....” Dou, Fig. 3B (annotated below), [0032]. Weide, ¶138.

Dou+Jing modifies Dou’s ground plane 310, which serves “to improve antenna performance in talk position and reduce SAR.” *Supra* §VI.C (combination), Dou, Fig. 3B (modified below), [0034]; Weide, ¶139.

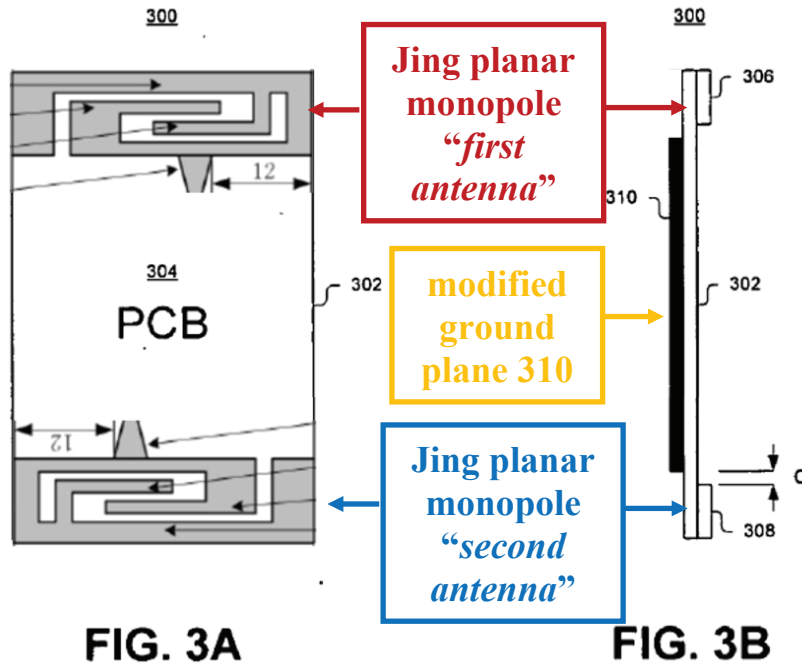


FIG. 3A

FIG. 3B

Dou+Jing

c. Element [1.b]

[1.b]	a first antenna proximate to a first short side of a ground plane rectangle enclosing the ground plane,
-------	---

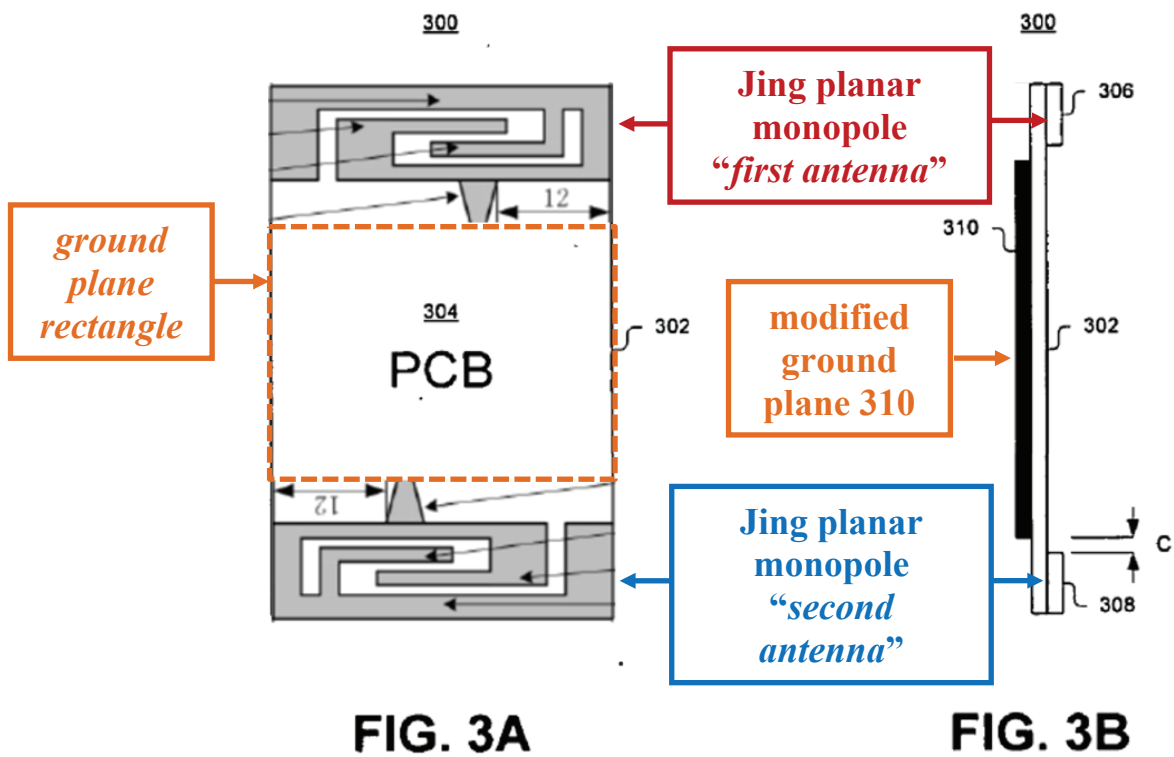
Dou+Jing meets [1.b] because Dou's antenna 306 (*first antenna*) is "located substantially at the top of... the PCB 304[.]" Dou, [0032]-[0033]. Dou describes ground plane 310 disposed on the back of PCB 304. Dou, Fig. 3B, [0032], [0034].

In Dou+Jing, ground plane 310 conforms to the dimensions of the ground plane in Jing, which is coterminous with the FR4 substrate (e.g., with dimensions 36 mm × 60 mm) but not extending beneath Jing's antenna. Jing, 2657-2658, Fig. 1(a). Jing places its antenna on the substrate's top surface "*proximate*" to a 36 mm wide edge (*first short side*) of a rectangle enclosing the ground plane on the

substrate's opposite side. Jing, 2658, Fig. 1(a) (below). *Supra* §VI.C

(combination); Weide, ¶141.

In Dou+Jing, modified ground plane 310 is bounded (e.g., *enclos[ed]*) by a 36 mm × 60 mm rectangle (*ground plane rectangle*) as Jing describes. Weide, ¶142. Jing's antenna implementing Dou's antenna 306 is "*proximate to a first side*" of that *ground plane rectangle* because it extends from the 36 mm *first short side* of the rectangle enclosing the ground plane. Jing, 2657-2658, Fig. 1(a); Dou, Figs. 3A-3B (as modified below), [0032]-[0034] (antenna is "located substantially at the top of... the PCB 304," but "the ground plane 310 does not extend underneath" it); *supra* §VI.C (combination); Weide, ¶142.



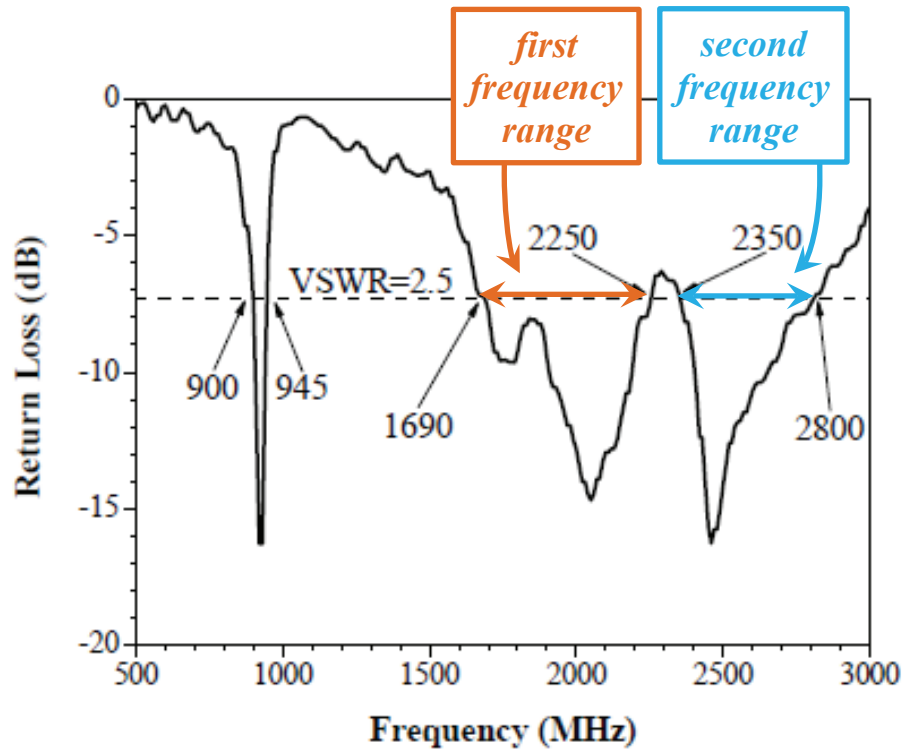
Dou+Jing

**d. Element [1.c]**

[1.c]	the first antenna being configured to support at least three frequency bands contained within first and second frequency ranges of the electromagnetic spectrum, the second frequency range being higher in frequency than the first frequency range,
-------	---

The plain meaning of “*at least three frequency bands contained within the first and second frequency ranges*” is that the first and second frequency ranges together contain within them “*at least three frequency bands.*” This is also how Fractus construes the same language in its litigation arguments on the parent ’677 patent. EX1024, 20-21; Weide, ¶143.

Dou+Jing meets [1.c] because Jing’s antenna (*first antenna*) operates—within the “*electromagnetic spectrum*”—at 1690-2250 MHz (*first frequency range*) and 2350-2800 MHz (*second frequency range*), which is “*higher in frequency*” than 1690-2250 MHz. Jing, 2658, Fig. 3 (annotated below); Weide, ¶144.



The 1690-2250 MHz range contains at least **twenty-one** “frequency bands” shown in Table 1.

**Table 1: Frequency bands within 1690-2250 MHz.**

<b>Band</b>	<b>Range (MHz)</b>
DCS1800	1710-1880
PCS1900	1850-1990
UMTS Band I	1920-2170
UMTS Band II	1850-1990
UMTS Band III	1710-1880
UMTS Band IV	1710-2155
UMTS Band a	1900-1920, 2010-2025
UMTS Band b	1850-1910, 1930-1990
UMTS Band c	1910-1930
LTE Band 1	1920-2170
LTE Band 2	1850-1990
LTE Band 3	1710-1880
LTE Band 4	1710-2155
LTE Band 9	1749.9-1879.9
LTE Band 10	1710-2170
LTE Band 33	1900-1920
LTE Band 34	2010-2025
LTE Band 35	1850-1910
LTE Band 36	1930-1990
LTE Band 37	1910-1930
LTE Band 39	1880-1920

Jing, 2658 (DCS, PCS, UMTS); EX1030, 8-9 (DCS1800, PCS1900); EX1039, 139 (reference [100] identifies HSDPA specifications), 497-501, 599 (reference [100] is 3GPP TS 25.308 (EX1032)); EX1032 (UMTS HSDPA description); EX1035, 11-12 (UMTS standard comprises TS 25.101 (EX1033), 25.102 (EX1034), 25.308 (EX1032)); EX1033, 12-13 (Table 5.0 “UTRA FDD frequency bands”); EX1034,

11 (UTRA/TDD frequency bands);<sup>7</sup> EX1025, 13, Table 5.5-1 (“E-UTRA operating bands” defining LTE bands); EX1026, 11 (listing LTE FDD and TDD bands); Weide, ¶¶146, 148-152.

The **2350-2800 MHz** range contains at least **three** “frequency bands” shown in Table 2.

**Table 2: Frequency bands within 2350-2800 MHz.**

<b>Band</b>	<b>Range (MHz)</b>
ISM 2.4 GHz	2400-2500
LTE Band 7	2500-2690
LTE Band 38	2570-2620

Jing, 2658 (WLAN); EX1024, 27 (Fractus citing LTE bands); EX1025, 13, Table 5.5-1 (“E-UTRA operating bands” defining LTE bands); EX1026, 11 (listing LTE FDD and TDD bands); EX1031, 70 (listing ZigBee bands); EX1039, 497-501; EX1043, 1 (defining the 802.11 band); EX1044, 29 (defining Bluetooth band); Weide, ¶¶147, 150-152.

Thus, Jing’s antenna meets [1.c] because it operates in (e.g., is operable to send and receive radiation in) at least twenty-one (21) bands in the *first frequency range* and at least three (3) bands in the *second frequency range*. Weide, ¶153.

---

<sup>7</sup> While Dou refers to “WCDMA/UMTS” in 1710-2170 MHz (Dou, [0022]), as shown in Table 1 the standard defines at least seven distinct “bands” within the 1710-2170 MHz frequency range. Weide, ¶145.

e. Element [1.d]

[1.d]	the first antenna being configured to transmit and receive signals from a 4G communication standard,
-------	--

Additional to the frequency bands discussed *supra* §VI.D.1.d ([1.c]), Jing’s antenna also covers the 900-945 MHz frequency range encompassing the ISM 902-928 MHz frequency band. Jing, 2658, Fig. 3; EX1003, 10:24-34 (discussing ISM 902-928 MHz); Weide, ¶154. Dou+Jing thus meets [1.d] several different ways.

**First**, the ’200 patent expressly defines HSDPA as a “4G feature” and “4G service” that it equates with a “4G standard.” EX1003, 25:14-20; *supra* §V.G (claim construction). HSDPA is part of the Universal Mobile Telecommunications System (UMTS) and supported by the UMTS frequency bands. EX1039, 139, 599 (EX1032 identifies HSDPA specification); EX1032 (UMTS HSDPA description); EX1035, 11-12 (UMTS standard comprises 3GPP TS 25.101 (EX1033), 25.102 (EX1034), 25.308 (EX1032)); Weide, ¶155.

Jing’s antenna supports at least seven (7) UMTS frequency bands, and such UMTS signals are each “*signals from a 4G communication standard*” at least because they support HSDPA. *Supra* §VI.D.1.d ([1.c]), Table 1; Weide, ¶156.

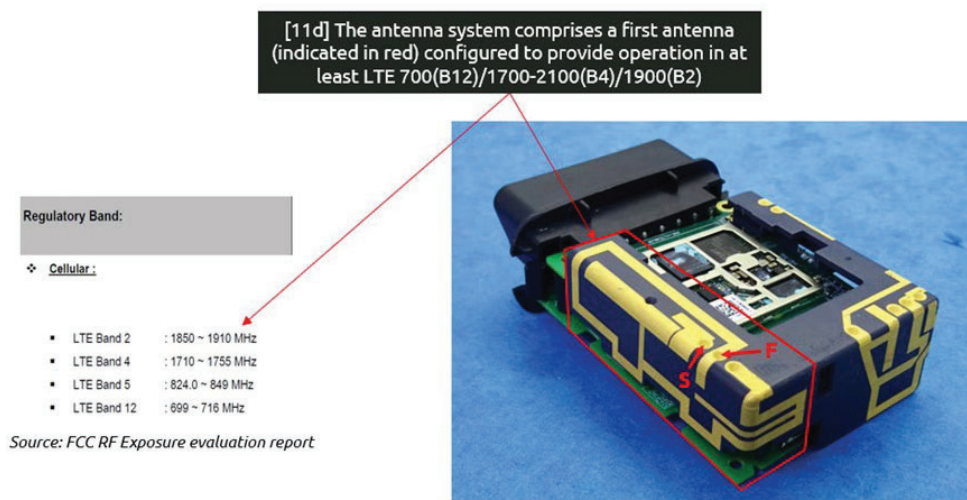
**Second**, the ’200 patent expressly identifies “WiBro, WiFi, WiMAX, UWB or other high-speed wireless standards” as “4G services.” EX1003, 25:14-18. The specification explains that WiFi encompasses IEEE Std. 802.11 WLAN. EX1003,

10:27; Weide, ¶157. WLAN (e.g., WiFi) and Bluetooth use 2400-2484 MHz within the 2.4 GHz ISM band (2400-2500 MHz), which Jing’s antenna covers, as explained above. EX1043, 1 (defining the 802.11 standard using 2.4 GHz ISM band); EX1044, 29 (defining Bluetooth standard using 2.4 GHz ISM band); Weide, ¶157. Jing’s antenna is capable of transmitting and receiving WLAN and Bluetooth signals, which are each separately “*signals from a 4G communication standard.*” Weide, ¶157.

**Third**, as the ’200 patent recognizes, Zigbee is a “high-speed wireless standard” for wireless networking like WiFi, Bluetooth, and UWB. EX1031, 17-18 (Zigbee uses IEEE Std. 802.15.4 wireless networking layers, provides wireless peer-to-peer communication in mesh networks), 31; EX1003, 10:24-34, 25:14-18. Zigbee is thus a “*4G communication standard*” because it is a “wireless standard” for “4G services” (*supra* §V.G). Weide, ¶158. Zigbee uses the ISM bands at 902-928 MHz and 2400-2500 MHz. EX1031, 17 (IEEE 802.15.4-2003, PHY layers at 915 MHz and 2400 MHz), 18, Fig. 1 (same), 70 (Table 23); Weide, ¶158. Jing’s antenna is capable of transmitting and receiving Zigbee signals, which are “*signals from a 4G communication standard.*” *Supra* §VI.D.1.d ([1.c]), Table 2; Weide, ¶158.

**Fourth**, as explained *supra* §V.G, Fractus argues in litigation that an antenna that can send/receive signals using LTE meets Fractus’s construction of

“receive signals from a 4G communication standard” as “the antenna could interact with a signal sent by a Fourth generation cellular technology to obtain or receive electromagnetic energy.” EX1017, 18 n.8; Weide, ¶159. Fractus also argues in litigation that [11.b] “antenna configured to provide operation in at least three frequency bands being used by 4G communication standards” is met by LTE bands. E.g., EX1024, 27 (excerpt below); EX1039, 497-502 (describing LTE frequency bands); see also EX1049, 4-5, 9, 20; EX1050, 4-5, 9, 20; EX1051, 4; EX1052, 3-4, 8, 19-20, 24; EX1053, 4; EX1054, 4; EX1055, 4; EX1056, 3-4, 8, 18; EX1057, 4, 9, 16-17, 21, 31; EX1058, 4-5, 9, 20; EX1059, 3-4, 8, 19-20, 24.



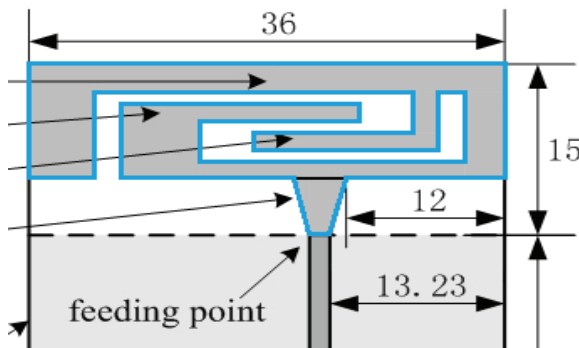
EX1024, 27.

Jing’s antenna is capable of transmitting and receiving signals in fourteen (14) LTE bands that are each “signals from a 4G communication standard” under Fractus’s litigation arguments. *Supra* §§V.G.2, VI.D.1.d ([1.c]), Tables 1, 2; Weide, ¶160.

f. Element [1.e]

[1.e]	the first antenna defining a first antenna contour comprising an entire perimeter of the first antenna, and
-------	---

Jing’s antenna “*defin[es] a first antenna contour comprising an entire perimeter of the first antenna*” just like the perimeter of antenna contour 350 in the ’200 patent’s embodiments in Figure 3 or antenna system 1200 in Figure 12A (below right), meeting [1.e]. EX1003, 7:62-64, 33:65-34:7; *see also* EX1024, 28 (Fractus applying “*antenna contour*”); EX1049, 6 (same); EX1058, 6 (same); *supra* §§V.A (perimeter), V.D (antenna contour); Jing, 2658 (“The planar monopole occupies an area of 36x15 mm<sup>2</sup>.”); Weide, ¶¶161-162.



Jing, Fig. 1(a) (in part, annotated)

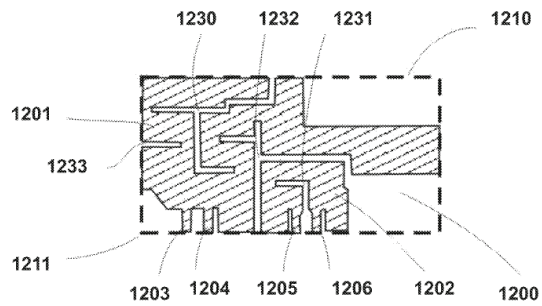
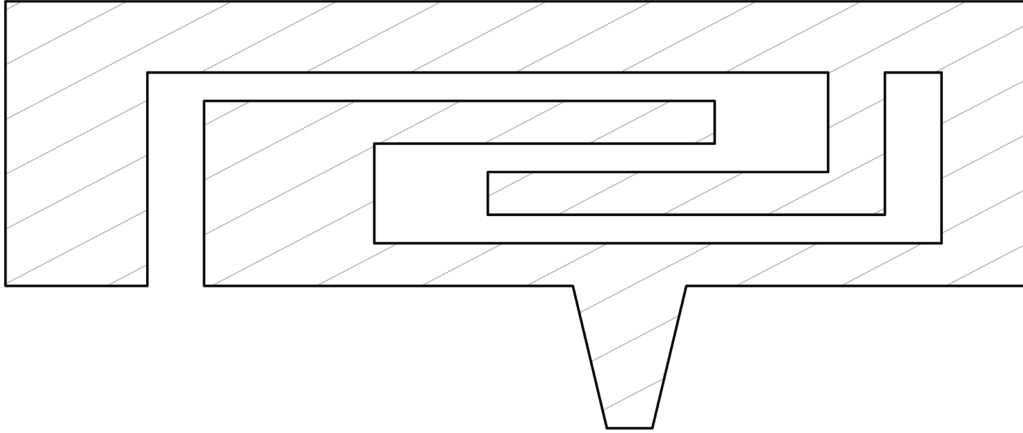


FIG. 12A

’200 patent

Jing’s antenna contour is shown below with slant-fill marking the conductive elements bounded by the contour as in the ’200 patent (e.g., Figs. 12A, 13A). Weide, ¶¶163-165.



**g. Element [1.f]**

[1.f]	wherein the first antenna contour has a level of complexity defined by complexity factor $F_{21}$ having a value of at least 1.20 and complexity factor $F_{32}$ having a value of at least 1.35; and
-------	---

Dou+Jing meets [1.f] because Jing’s antenna contour (“*first antenna contour*”) has *complexity factor*  $F_{21} = 1.43$  (“*at least 1.20*”) and  $F_{32} = 1.70$  (“*at least 1.35*”). Weide, ¶166.

**i. Calculating  $F_{21}$**

**(1) Grid  $G_2$**

The ’200 patent identifies a preferred embodiment wherein second grid  $G_2$  has nine columns. EX1003, 17:49-51. With a 36 mm × 15 mm *antenna rectangle* (Jing, Fig. 1(a)) **nine columns** yields a cell width  $\left(\frac{36\text{ mm}}{9}\right) = 4.0$  mm. Weide, ¶167.

Setting an odd number of “ $2n+1$ ” rows with integer  $n$  such that  $0 < n < 5$  yields these results, where aspect ratio is the ratio of cell width to cell height (EX1003, 17:28-32, 18:8-10):

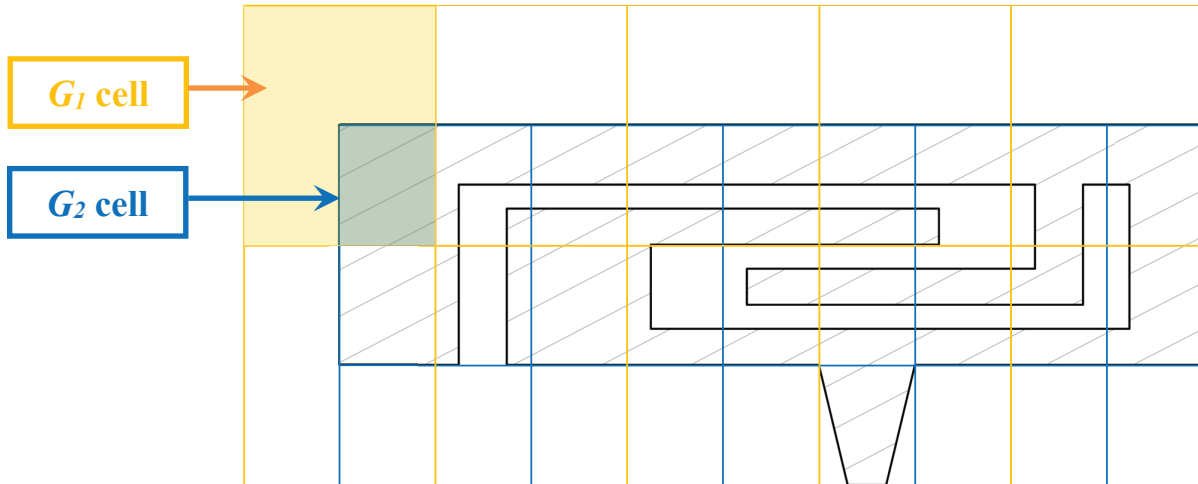
# rows	cell height (mm)	aspect ratio
3	$\left(\frac{15 \text{ mm}}{3}\right) = 5.0$	$\left(\frac{4.0}{5.0}\right) = 0.80$
5	$\left(\frac{15 \text{ mm}}{5}\right) = 3.0$	$\left(\frac{4.0}{3.0}\right) = 1.33$

Therefore, **three** rows provides grid cells “as square as possible,” e.g., an aspect ratio closest to one. *Supra* §V.E.1.a (claim construction); EX1003, 17:5-8, 17:28-18:3; Weide, ¶167. Thus, grid  $G_2$  with **nine (9) columns** and **three (3) rows** has cells “as square as possible[.]” Weide, ¶168.

(2)  $N_2 = 27$ .

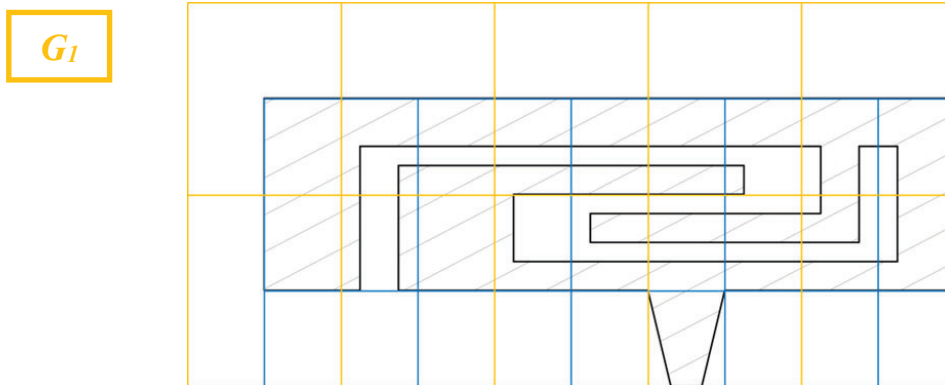
The 3 x 9 grid  $G_2$  (blue outline) is superimposed over the Jing’s *antenna contour* below. Weide, ¶169. The ’200 patent states that “in the present invention the boundary of the cell is also part of the cell.” EX1003, 19:12-20. Therefore, all twenty-seven (27) cells in  $G_2$  are included in  $N_2$  because all cells have a boundary that coincides with the *antenna contour*. Weide, ¶¶169-170. Thus, all cells





(4)  $N_I = 10$ .

All cells within  $G_I$  “include at least a point of the antenna contour,” making  $N_1 = 10$ . *Supra* §V.E.2.a; EX1003, 19:12-20; Weide, ¶172.



(5) Calculation  $F_{21} = 1.43$ .

The complexity factor  $F_{21}$  for Jing’s antenna contour is thus:

$$\begin{aligned}
 F_{21} &= -\left(\frac{\log(N_2) - \log(N_1)}{\log(1/2)}\right) = -\left(\frac{\log(27) - \log(10)}{(-1)\log(2)}\right) \\
 &= \left(\frac{\log(27/10)}{\log(2)}\right) = \left(\frac{0.431}{0.301}\right) = 1.43.
 \end{aligned}$$

*Supra* §V.E.2.a; EX1003, 19:12-25; Weide, ¶173.

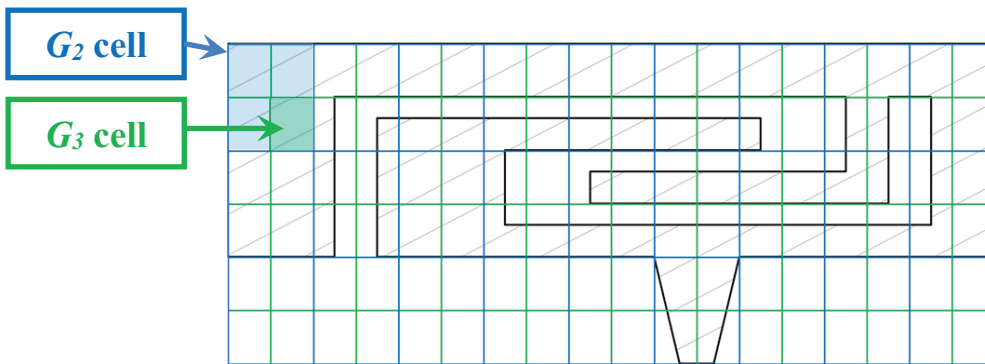
## ii. Calculating $F_{32}$

### (1) Grid $G_3$

Grid  $G_3$  is 6 rows by 18 columns (e.g., twice as many rows and columns as  $G_2$ ) so that a single  $G_2$  cell (blue outline) contains four  $G_3$  cells (green outline).

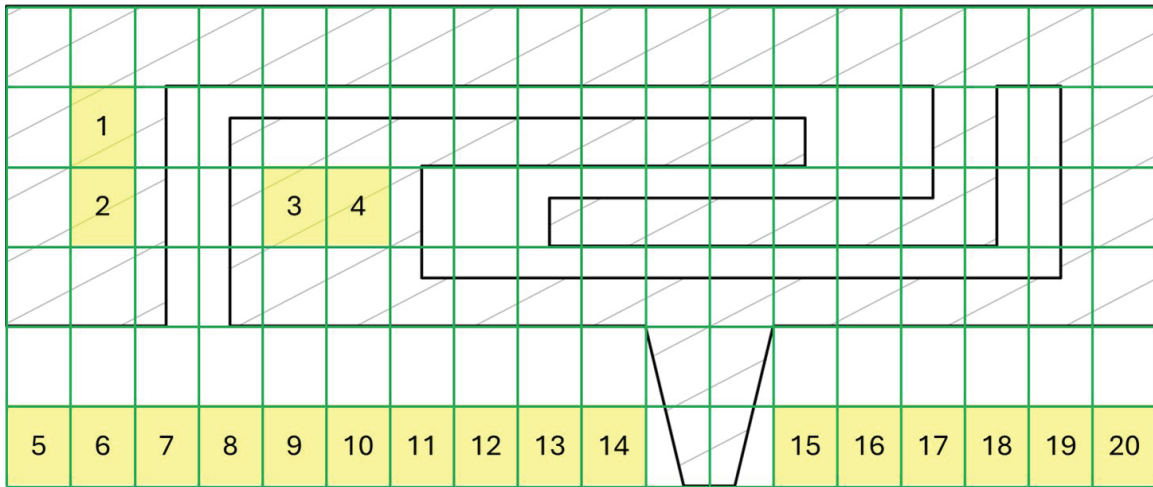
*Supra* §V.E.1.c; EX1003, 19:62-20:4; Weide, ¶174. The  $G_3$  cells have width

$\left(\frac{36mm}{18}\right) = 2.0$  mm and height  $\left(\frac{15mm}{6}\right) = 2.5$  mm. Weide, ¶174.



(2)  $N_3 = 88$ .

As shown below 20 numbered  $G_3$  cells do *not* “include at least a point of the antenna contour.” *Supra* §V.E.2.b; EX1003, 20:1-11; Weide, ¶175. Thus, the  $G_3$  cell count  $N_3 = (108 - 20) = 88$ . Weide, ¶¶175-177.



(3) Calculation  $F_{32} = 1.70$ .

The complexity factor  $F_{32}$  for Jing’s antenna contour is thus:

$$\begin{aligned}
 F_{32} &= -\left(\frac{\log(N_3) - \log(N_2)}{\log(1/2)}\right) = -\left(\frac{\log(88) - \log(27)}{(-1)\log(2)}\right) \\
 &= \left(\frac{\log(88/27)}{\log(2)}\right) = \left(\frac{0.513}{0.301}\right) = 1.70.
 \end{aligned}$$

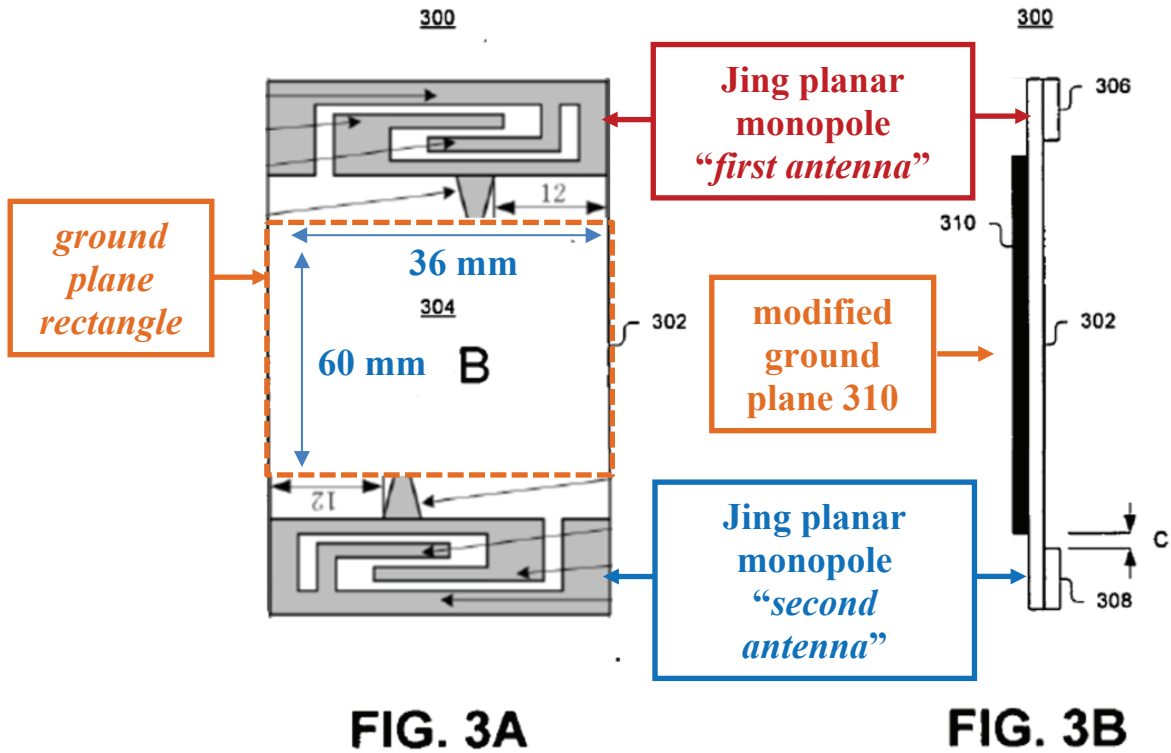
*Supra* §V.E.2.b; EX1003, 20:5-17; Weide, ¶178.

**h. Element [1.g]**

[1.g]	a second antenna proximate to a first long side of the ground plane rectangle,
-------	--

Dou+Jing meets [1.g] because it implements Dou antenna 308 as a Jing antenna (*second antenna*). *Supra* §VI.C (combination); Weide, ¶179. Jing’s antenna is 36 mm wide and extends at each end to the two long edges of PCB 302, as shown below (modified Dou Figs. 3A-3B). Each long edge of PCB 302 coincides with a “*long side of the ground plane rectangle*” that encloses modified ground plane 310 shown below. *Supra* §§VI.C (combination), VI.D.1.b ([1.a]); Weide, ¶179.

Since Jing’s antenna and ground plane are both 36 mm wide, and positioned next to the ground plane rectangle, using two Jing antennas in Dou’s device locates both antennas “*proximate to*” a short side (36 mm edge) and a “*long side*” (60 mm edge) of “*the ground plane rectangle*” (orange outline). *Supra* §VI.C (combination); Weide, ¶180.



**FIG. 3A**

**FIG. 3B**

Dou+Jing

**i. Element [1.h]**

[1.h]	and wherein the second antenna is configured to receive signals from a 4G communication standard.
-------	---

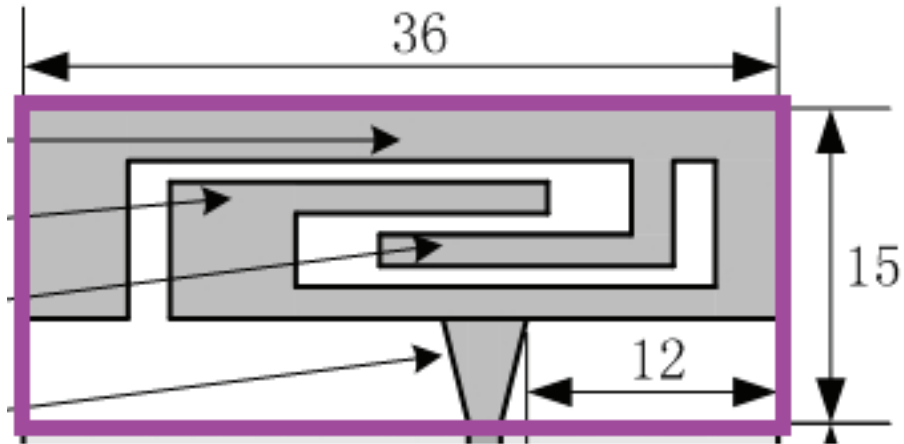
Dou+Jing meets [1.h] because Jing’s antenna (*second antenna, supra* §VI.D.1.h ([1.g])) “*is configured to receive signals from a 4G communication standard*” in the same way Jing’s antenna (*first antenna*) does for [1.d] *supra* §VI.D.1.e. Weide, ¶181.

## 2. Claim 2

[2]	[Claim 1's device], wherein the second antenna defines an antenna box that is a minimum-sized parallelepiped that completely encloses a volume of the second antenna and wherein each face of the minimum-sized parallelepiped is tangent to at least one point of the volume of the second antenna, an orthogonal projection of the antenna box along a normal to a face with a largest area of the second antenna defining an antenna rectangle, an aspect ratio of the antenna rectangle being defined as a ratio between a width and a height of the antenna rectangle, and wherein the aspect ratio has a value of at least 2.
-----	---

Dou+Jing's device comprises Jing's antenna (*second antenna*). *Supra* §§VI.D.1.h ([1.g]), VI.C (Dou+Jing). Weide, ¶182.

Jing's antenna is a "planar monopole antenna with a 2-dimensional structure" having an area of  $36 \times 15 \text{ mm}^2$ . Jing, 2657. Accordingly, the "*antenna box*" of Jing's antenna ("*a minimum-sized parallelepiped that completely encloses a volume of the first antenna and wherein each face of the minimum-sized parallelepiped is tangent to at least one point of the volume*") is the antenna's rectangular area of  $36 \times 15 \text{ mm}^2$ . *Supra* §V.B (*antenna box*); Weide, ¶183. Thus, "*an orthogonal projection of the antenna box along a normal to a face with a largest area of the first antenna defining an antenna rectangle*" is a rectangle enclosing a  $36 \times 15 \text{ mm}^2$  area encompassing Jing's antenna. Jing, Fig. 1(a) (detail below); Weide, ¶183.

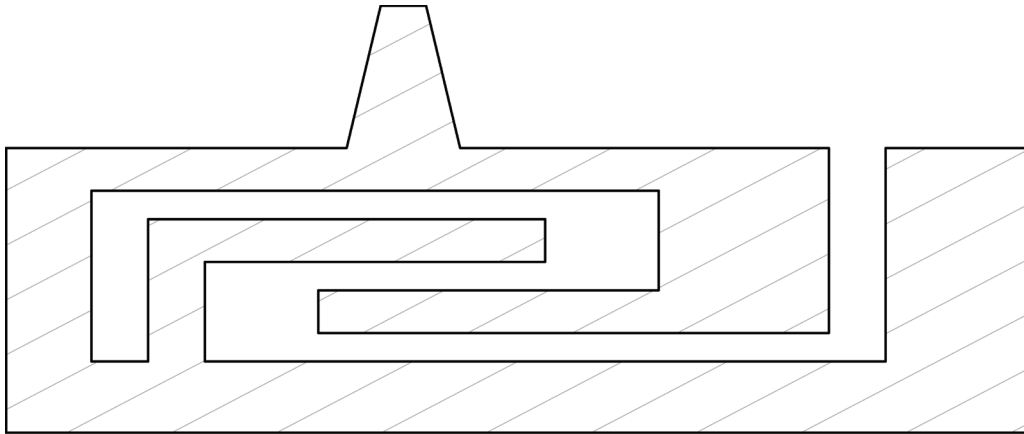


The “*aspect ratio*” of Jing’s “*antenna rectangle being defined as a ratio between a width and a height of the antenna rectangle*” is  $\left(\frac{36}{15}\right) = 2.4 > 2$ . Weide, ¶184. This meets claim 2.

### 3. Claim 3

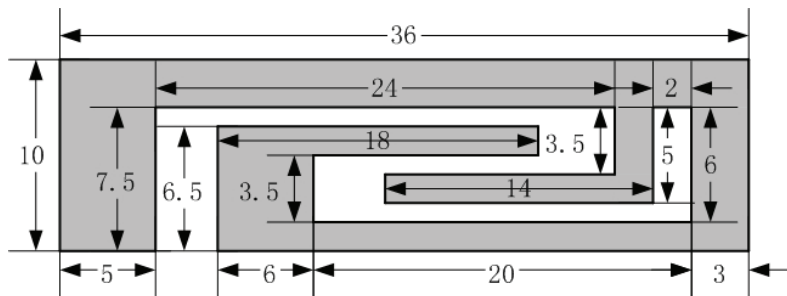
[3]	[Claim 2’s device], wherein the second antenna defines a second antenna contour comprising an entire perimeter of the second antenna, wherein a length of the second antenna contour is greater than four times a diagonal of the antenna rectangle.
-----	--

For the same reasons discussed *supra* §VI.D.1.f ([1.e]) for the *first antenna*, Dou’s antenna 308 implementing a second Jing antenna “*defines a second antenna contour comprising an entire perimeter of the second antenna.*” Weide, ¶185.

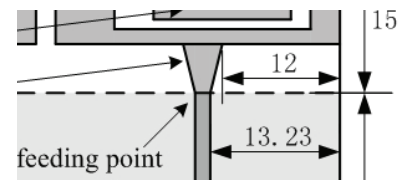


Jing's antenna contour (located as Dou's antenna 308)

The length of Jing's antenna contour is defined by Jing's measurements in Figures 1(a) and 1(b) (below) and Jing's description stating that the 5 mm-high tapered portion is "4 mm at the edge of the patch" and "1.54 mm at the feeding point." Jing, 2657-2658. Figs. 1(a), 1(b). Weide, ¶186.

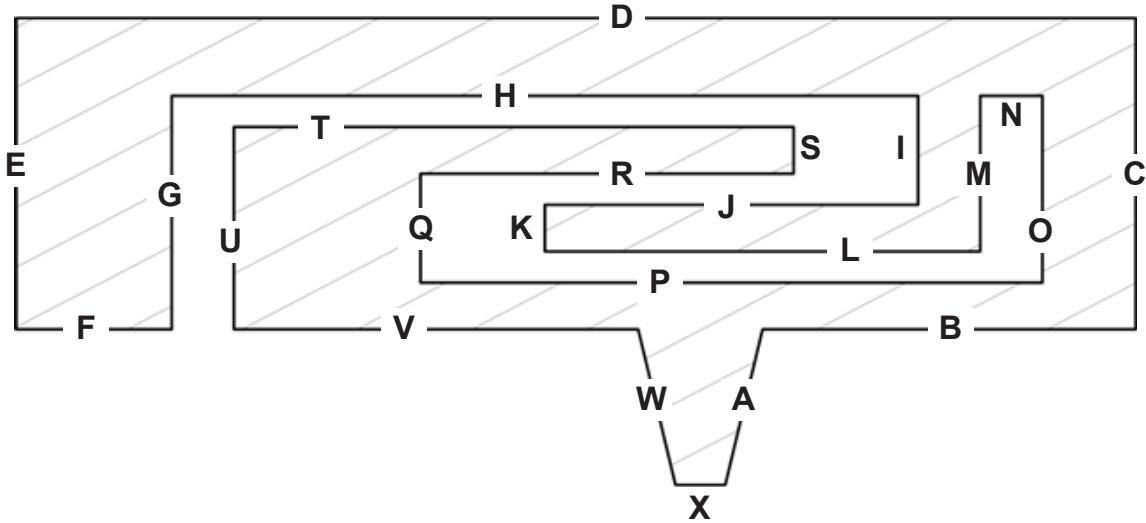


Jing, Fig. 1(b)



Jing, Fig. 1(a) (in part)

Each segment of Jing's *antenna contour* is labeled in the figure below for clarity:



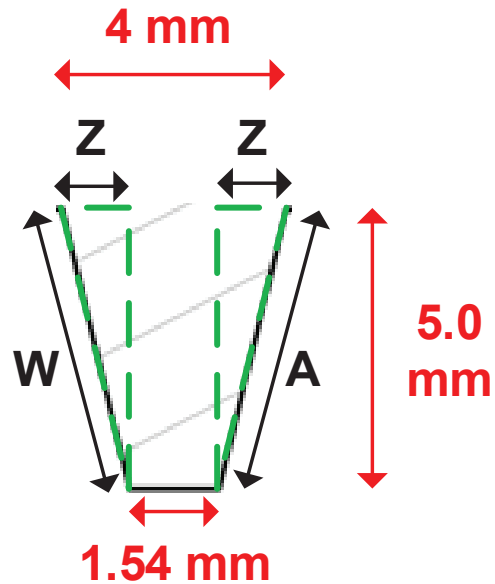
The length of segment **V** (13 mm) is determined by subtracting the length of segment **B** (12 mm) (Jing, Fig. 1(a)) and the length where the tapered strip meets the patch (4 mm) (Jing, 2658) from the entire length of the segment that meets the tapered strip (29 mm) (Jing, Fig. 1(b)) (i.e.,  $V = 13 = 29 - 12 - 4$ ). Weide, ¶188.

The length of segment **X** is specified by Jing as 1.54 mm. Jing, 2658. The lengths of segments **A** and **W** are determined using the length of segment **X** (1.54 mm), the 4 mm length where the tapered strip meets the patch (Jing, 2658), and the height of the tapered strip (5 mm) (Jing, 2658) by calculating the hypotenuse (**A** and **W**) of the right triangles indicated in green in the figure below, where the top of the triangle (**Z**) is half of the difference between the top of tapered strip (4 mm) and the bottom of tapered strip (1.54 mm):

$$Z = 1.23 \text{ mm} = \frac{4.0 \text{ mm} - 1.54 \text{ mm}}{2}$$

$$A = W = \sqrt{(5.0 \text{ mm})^2 + (1.23 \text{ mm})^2}$$

$$A = W = 5.15 \text{ mm} = \sqrt{26.51 \text{ mm}^2}$$



The lengths of segments C-U are provided by Jing's Figure 1(b). Weide, ¶189.

The following table provides the lengths (in mm) of segments A-X:

Segment	Length	Segment	Length	Segment	Length
A	5.15	I	3.5	Q	3.5
B	12	J	12	R	12
C	10	K	1.5	S	1.5
D	36	L	14	T	18
E	10	M	5	U	6.5
F	5	N	2	V	13
G	7.5	O	6	W	5.15
H	24	P	20	X	1.54
<b>Total</b>	<b>109.65</b>	<b>Total</b>	<b>64</b>	<b>Total</b>	<b>61.19</b>

Thus, Jing's "length of the second antenna contour" is **234.84 mm** (109.65 mm + 64 mm + 61.19 mm). Weide, ¶190.

Jing’s *antenna rectangle* is 36 mm by 15 mm which defines “*a diagonal of the antenna rectangle*” of 39 mm as follows:

$$39 \text{ mm} = \sqrt{(36 \text{ mm})^2 + (15 \text{ mm})^2}$$

Weide, ¶191.

Dou+Jing meets claim 3 because “*a length of the second antenna contour*” (i.e., 234.84 mm) “*is greater than four times a diagonal of the antenna rectangle*” (i.e.,  $4 \times 39 \text{ mm} = 156 \text{ mm}$ ). Weide, ¶192.

#### 4. Claims 4, 5

[4]	[Claim 1’s device], wherein the first antenna is configured to support at least four frequency bands.
[5]	[Claim 1’s device], wherein the first antenna is configured to support at least five frequency bands.

Dou+Jing meets claims 4 and 5 for the same reasons discussed *supra* §§VI.D.1.d ([1.c]), VI.D.1.e ([1.d]), since Jing’s antenna (*first antenna*) is *configured to support* twenty-four (24) frequency bands. Weide, ¶193.

#### 5. Claim 6

##### a. Elements [6.PRE]-[6.a], [6.d]-[6.e], [6.g]

Dou+Jing meets Elements [6.PRE]-[6.a], [6.d]-[6.e], and [6.g] for the reasons it meets the corresponding limitations below. EX1028, 1-3; Weide, ¶194.

Element	Corresponding Limitation	Discussion <i>supra</i>
[6.PRE]	[1.PRE]	§VI.D.1.a

Element	Corresponding Limitation	Discussion <i>supra</i>
[6.a]	[1.a]	§VI.D.1.b
[6.d]	[1.e]	§VI.D.1.f
[6.e]	[1.f]	§VI.D.1.g
[6.g]	Claim 2	§VI.D.2

Dou+Jing meets the remaining limitations of claim 6 as follows.

**b. Element [6.b]**

[6.b]	a first antenna configured to provide operation in at least four frequency bands being used by 4G communication standards,
-------	--

Dou+Jing meets [6.b] because, as discussed *supra* §VI.D.1.e ([1.d]), Dou’s antenna 306 (*first antenna*) implemented using Jing supports at least seven UMTS frequency bands supporting HSDPA, two ZigBee bands (ISM 902-928 and ISM 2400), and fourteen LTE bands, each “*being used by 4G communication standards.*” Weide, ¶196. Jing’s antenna therefore *provides operation in at least* twenty-three “*frequency bands being used by 4G communication standards.*” Weide, ¶196.

**c. Element [6.c]**

[6.c]	wherein at least two of the at least four frequency bands are contained within a first frequency range and at least two of the four frequency bands are contained within a second frequency range, the first frequency range being lower in frequency than the second frequency range,
-------	--

The antecedent for “four frequency bands” is [6.b]. As discussed *supra* §§VI.D.1.d-VI.D.1.e ([1.c]-[1.d]), Jing’s antenna supports *a first frequency range* at 1690-2250 MHz and *a second frequency range* at 2350-2800 MHz, wherein the “*first frequency range*” (1690-2250 MHz) is “*lower in frequency than the second frequency range*” (2350-2800 MHz). *Supra* §§VI.D.1.d ([1.c]); Jing, 2658, Fig. 3; Weide, ¶197.

The “*first frequency range*” (1690-2250 MHz) supports twenty-one frequency bands of which the nineteen (19) UMTS and LTE bands are “*used by 4G communication standards*” meeting [6.b], while the “*second frequency range*” (2350-2800 MHz) supports at least three frequency bands, each of which (ISM 2.4 GHz, LTE band 7, and LTE band 38) is “*used by 4G communication standards.*” *Supra* §§VI.D.1.d ([1.c]), VI.D.1.e ([1.d]), VI.D.5.b ([6.b]); Weide, ¶198.

**d. Element [6.f]**

[6.f]	a second antenna configured to operate in at least one frequency band being used by a 4G communication standard,
-------	--

Dou+Jing meets [6.f] because, as discussed *supra* §§VI.D.1.h ([1.g]), VI.D.5.b ([6.b]), VI.D.5.c ([6.c]), Dou’s *second antenna* 308 implementing Jing operates in at least ten “*frequency band[s] being used by a 4G communication standard.*” Weide, ¶199.

e. Element [6.h]

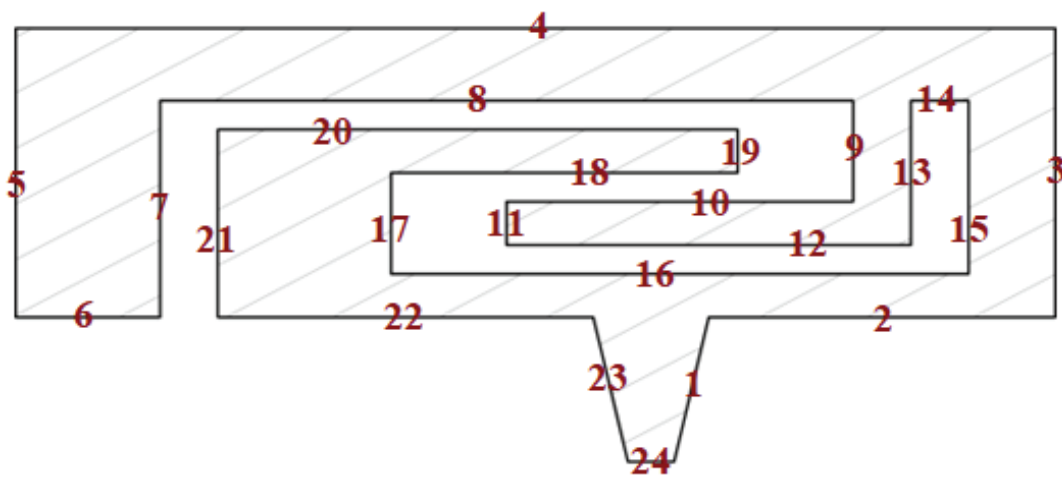
[6.h]	and wherein at least one of the first and second antennas is close to a first short side of a ground plane rectangle enclosing the ground plane.
-------	--

Dou+Jing meets [6.h] for the reasons discussed *supra* §§VI.D.1.c ([1.b]), VI.D.1.h ([1.g]) because Dou+Jing’s antennas 306, 308 are both located “*close to*” the top and bottom, respectively, of “*a first short side of a ground plane rectangle enclosing the ground plane.*” Weide, ¶200.

6. Claim 7

[7]	[Claim 6’s device], wherein the first antenna contour comprises at least 20 segments.
-----	---

As discussed *supra* §§VI.D.1.f ([1.e]), Jing’s antenna implemented as Dou’s antenna 306 (*first antenna*) has an antenna contour shown below, which comprises 24 (*at least 20*) segments. Jing, Fig. 1(a)-(b); Weide, ¶201.



## 7. Claim 8

[8]	[Claim 6's device ], wherein at least one of the first and second antennas is close to a first long side of the ground plane rectangle.
-----	---

Dou+Jing meets claim 8 for each *first* and *second* Jing *antenna* for the reasons discussed *supra* §VI.D.1.h ([1.g]). Weide, ¶202.

## 8. Claim 9

[9]	[Claim 6's device], wherein the second antenna defines a second antenna contour comprising an entire perimeter of the second antenna, wherein a length of the second antenna contour is greater than four times a diagonal of the antenna rectangle.
-----	--

Dou+Jing meets claim 9 for the reasons it meets claim 3. *Supra* §VI.D.3 (claim 3); Weide, ¶203.

## 9. Claim 10

[10]	[Claim 6's device], wherein the antenna system comprises a third antenna configured to provide operation in a wireless communication standard.
------	--

Dou+Jing meets claim 10 because it includes a dedicated Bluetooth antenna (*third antenna*). *Supra* §VI.C (Dou+Jing); Weide, ¶204. The Bluetooth antenna is “*configured to provide operation in a wireless communication standard,*” e.g., Bluetooth. EX1044 (Bluetooth specification); Weide, ¶204.

**10. Claim 11**

**a. Elements [11.PRE]-[11.f], and [11.h]**

Dou+Jing meets Elements [11.PRE]-[11.f], and [11.h] for the reasons it meets the corresponding limitations below. EX1028, 4-8; Weide, ¶205.

<b>Element</b>	<b>Corresponding Limitation</b>	<b>Discussion <i>supra</i></b>
[11.PRE]	[1.PRE]	§VI.D.1.a
[11.a]	[1.a]	§VI.D.1.b
[11.b]	[6.b]	§VI.D.5.b
[11.c]	[1.e]	§VI.D.1.f
[11.d]	Claim 7	§VI.D.6
[11.e]	[1.f]	§VI.D.1.g
[11.h]	[1.g], [6.h]	§§VI.D.1.h, VI.D.5.e

Dou+Jing meets [11.f], wherein Jing’s antenna is the *first antenna*, for the reasons it meets claim 2 (wherein Jing’s antenna is the “*second antenna*”), *supra* §VI.D.2; Weide, ¶206. Dou+Jing meets the remaining limitations of claim 11 as follows.

**b. Element [11.g]**

[11.g]	a second antenna configured to provide operation in a first wireless service,
--------	---

Dou+Jing meets [11.g] for the same reasons discussed *supra* §VI.D.1.h ([1.g]) wherein Jing’s antenna is the *second antenna* implementing Dou’s antenna 308. Weide, ¶207. As discussed *supra* §VI.D.1.d ([1.c]), Jing’s antenna operates

in the 2350-2800 MHz frequency range that supports the ISM 2.4 GHz band. Jing, 2658, Fig. 3. The ISM 2.4 GHz band is used by the WiFi standard, the ZigBee standard, and the Bluetooth standard, which are each a *wireless service*, meeting [11.g]. EX1003, 10:24-34 (defining “WiFi (IEEE802.11 standards), Bluetooth, [and] ZigBee” as “wireless connectivity” services); EX1031, 70 (listing ZigBee bands); EX1039, 497-501; EX1043, 1 (defining the IEEE802.11b band); EX1044, 29 (defining Bluetooth band); Weide, ¶207.

**11. Claim 12**

12	[Claim 11’s device], wherein the first antenna is configured to support at least four frequency bands.
----	--

Dou+Jing meets claims 12 for same reasons it meets claim 4. *Supra* §VI.D.4; EX1028, 7; Weide, ¶208.

**12. Claim 13**

[13]	[Claim 11’s device], wherein the first wireless service is a WiFi communication standard.
------	---

Dou+Jing meets claim 13 for the reasons it meets [11.g] *supra* §VI.D.10.b because Jing’s antenna provides operation at 2400-2484 MHz in the ISM 2.4 GHz band for the IEEE 802.11b standard (*first wireless service*), which is “a *WiFi communication standard*.” EX1003, 10:24-34; EX1043, 11, 49-50; Weide, ¶209.

### 13. Claim 14

[14]	[Claim 13’s device], wherein the first wireless service provides operation in the 2400-2480 MHz frequency range and the 5.1-5.9 GHz frequency range.
------	--

Dou+Jing meets claim 14 for the reasons it meets [11.g] and [13] *supra* §§VI.D.10.b, VI.D.12 because WiFi uses IEEE Std. 802.11 wireless networking (*first wireless service*), and IEEE Std. 802.11 includes IEEE Std. 802.11b *operating in* the “2400-2480 MHz frequency range” (EX1043, 11 (defining 802.11b)) and IEEE Std. 802.11a *operating in* “the 5.15–5.25, 5.25–5.35 and 5.725–5.825 GHz unlicensed national information infrastructure (U-NII) bands” (EX1042, 3 (defining 802.11a)). EX1003, 10:24-34 (defining “WiFi (IEEE802.11 standards)”); Weide, ¶210.

### 14. Claim 15, 17

[15]	[Claim 11’s device], wherein the antenna system comprises a third antenna.
[17]	[Claim 15’s device], wherein the third antenna is configured to provide operation in a second wireless service.

Dou+Jing meets claims 15 and 17 because it includes a GPS antenna (*third antenna*), and the GPS antenna is *configured to provide operation* with GPS, which is a *wireless service*. EX1003, 10:46-49 (describing “a geolocation service” as an example *wireless service*); EX1048, 2 (describing GPS as “a positioning and timing service” operating “through the band 1563.42 to 1587.42

MHz”); *supra* §VI.C (Dou+Jing); Dou, [0022], [0040], [0045]; *see also* EX1049, 32 (Fractus citing GPS as a “wireless service”); EX1050, 32 (same); EX1051, 16 (same); EX1054, 13-14 (same); EX1055, 13-14 (same); EX1056, 61 (same); EX1057, 43 (same); EX1058, 32 (same); Weide, ¶211.

**15. Claims 19, 20**

[19]	[Claim 15’s device], wherein the antenna system comprises a fourth antenna.
[20]	[Claim 19’s device], wherein the fourth antenna is configured to provide operation in a third wireless service.

Dou+Jing meets claims 19 and 20 because its device includes four antennas: two Jing antennas (*first and second antenna, supra* §§VI.D.1.b ([1.a]), VI.D.10.a ([11.b]), VI.D.10.b ([11.g])), a GPS antenna (*third antenna, supra* §VI.D.14 (claim 15)), and a dedicated Bluetooth antenna (*fourth antenna configured to provide operation in a third wireless service*). *Supra* §VI.C (combination); Dou, [0040] (“may comprise **three or more antennas**” including “any suitable type of internal antenna disposed within the housing of a wireless device”); EX1044 (Bluetooth specification); Weide, ¶212.

## VII. GROUND 2: BALIARDA-543 ANTICIPATES AND/OR RENDERS OBVIOUS CLAIMS 1-20

### A. Claims 1-20 Are Not Entitled To Priority Before April 7, 2014.

The '200 patent is a continuation of, *inter alia*, Application No. 11/614,429 (“the '429 application”) (EX1003, code (63)), filed December 21, 2006, published January 24, 2008 (EX1040, U.S. Patent Pub. No. 2008/018543, “Baliarda-543”).

For any Challenged Claim to be entitled to the '429 application's filing date, the '429 application must provide written description supporting that claim.

*Arthrex v. Smith & Nephew*, 35 F.4th 1328, 1343 (Fed. Cir. 2022).

Written description requires that the disclosure within the four corners of '429 application “reasonably conveys to [a POSA] that the inventor had possession of the [later-claimed] claimed subject matter as of the filing date,” e.g., December 21, 2006. *Regents of the Univ. of Cal. v. Broad Inst.*, No. 22-1653, slip op., 24 (Fed. Cir. May 12, 2025); *Ariad Pharms. v. Eli Lilly*, 598 F.3d 1336, 1351 (Fed. Cir. 2010) (en banc) (“The test requires an objective inquiry into the four corners of the specification from the perspective of a [POSA] to show that the inventor actually invented the invention claimed.”) (cleaned up).

The written description must support the full scope of the claimed subject matter. *Arthrex*, 35 F.4th at 1343-1344 (no written description supporting full scope of “first member including *an eyelet*” where priority document failed to

describe a flexible eyelet); *Rivera v. Int'l Trade Comm'n*, 857 F.3d 1315, 1319-1321 (Fed. Cir. 2017) (specification “did not provide the necessary written description support for the **full breadth** of the asserted claims” where claims were broadly drawn to a “container... adapted to hold brewing material” but the specification only disclosed a “pod adapter assembly” or “receptacle” designed to hold a “pod”), 1322 (“The specification here does not teach a container with an integrated filter, and so, does not provide written description support for such a container[.]”); *ICU Medical v. Alaris Med. Sys.*, 558 F.3d 1368, 1377-78 (Fed. Cir. 2009) (no written description for full scope of “a needleless connector valve comprising a body and a seal” without “any spike limitation” where priority document only described medical valves **with** spikes); *Google LLC v. Valtrus Innovations Ltd.*, IPR2022-01406, Paper 40, 60-61 (Apr. 3, 2024) (no written description supporting full scope of “computing domains” where priority document provided no description of virtual machines).

In December of 2006, there were discussions ongoing about 4G but what a 4G communication system would look like was undefined. Only years later did ITU's IMT-Advanced in Report ITU-R M.2134, adopted November 2008, define the requirements for a 4G communication system. EX1046; Weide, ¶220. An LTE communication **standard** was not defined until years after the '429

application was filed. EX1025; EX1026, 7 (LTE specification completed March 2009); Weide, ¶220.

*Claims 1-5* require that an antenna be “*configured to transmit and receive signals from a 4G communication standard*” ([1.d]), *claims 6-10* require that an antenna be “*configured to provide operation in at least four frequency bands being used by 4G communication standards*” ([6.b]), and *claims 11-20* require an antenna be “*configured to provide operation in at least three frequency bands being used by 4G communication standards*” ([11.b]). In litigation, Fractus argued that the claimed “*4G communication standard*” is met by LTE. *Supra* §V.G.2. The Board should hold Fractus to its litigation position that an LTE band is a “*frequency band associated with*”—e.g., ***being used by***— “*a 4G communication standard,*” which is fatal to the patentability of the claims challenged in Ground 2 for reasons explained below. *Supra* §V.G.2.

The '429 application provides no written description supporting the full scope of an “*antenna... being configured to transmit and receive signals from a 4G communication standard*” ([1.d]) or an “*antenna... configured to provide operation in at least [three or four] frequency bands being used by 4G communication standards*” ([6.b] and [11.b]) when the “*4G communication standard*” encompasses LTE. The '429 application provides no description of LTE, LTE frequency bands, or the 3GPP Technical Specification 36.101 V8.4.0 (2008-12)—

published years *after* the '429 application's filing—that defines LTE and its frequency bands. Baliarda-543; EX1025; EX1026, 7 (LTE specification completed in March 2009); EX1039, 497-502; Weide, ¶222.

On December 21, 2006, the LTE frequency bands *had not even been defined* and what frequency ranges they might eventually use was an “open issue.” EX1038 (February 2007 report), 112 (“Open issues... Is the evolved access system envisioned to work on new and/or existing frequency band?”); EX1037 (November 2006 report), 108 (same); EX1036 (June 2006 report), 84 (same); EX1039, 497-502 (LTE frequency bands); EX1025 (December 2008 document defining LTE bands), EX1026, 7 (LTE specification completed in March 2009); Weide, ¶¶223-228.

Indeed, LTE band 12 (699-716 MHz uplink and 728-746 MHz downlink, EX1039, 498 (Table 20.1))—whose uplink portion Fractus *expressly relies upon* for meeting limitation [11.b] in its complaint in the Geotab Litigation (EX1024, 27; *see also* EX1049, 4-5, 9, 20; EX1050, 4-5, 9, 20; EX1051, 4, EX1052, 3-4, 8, 19-20, 24; EX1053, 4; EX1054, 4; EX1055, 4; EX1056, 3-4, 8, 18; EX1057, 4, 9, 16-17, 21, 31; EX1058, 4-5, 9, 20; EX1059, 3-4, 8, 19-20, 24)—is part of a frequency range (698-806 MHz) that was *not even available for use with mobile communications* (let alone LTE) until WRC-07 in October-November 2007—*nearly a year after* Fractus's December 21, 2006 filing date for the '429

application. EX1041, 1 (WRC-07 took place in Geneva, Switzerland between October 22 and November 16, 2007); EX1039, 501 (“20.1.2 New frequency bands... *WRC-07 identified additional frequency bands* for IMT, which encompasses both IMT-2000 and IMT-Advanced. *Several bands were defined by WRC-07* that will be available partly or fully for deployment on a global basis:... *698-806 MHz was allocated to mobile service* and identified to IMT to some extent in all regions. Together with the band 806-960 MHz identified at WRC-2000, it forms a wide frequency range from 698 to 960 MHz that is partly identified to IMT in all regions, with some variations.”); Weide, ¶229. Within this 698-806 MHz range defined for mobile communications at WRC-07, LTE bands 12, 13, and 14 (EX1039, 498 (Table 20.1)) were “defined for operation mainly for US allocations.” EX1039, 501; Weide, ¶230.

Moreover in July 2007—before WRC-07—the spectrum at 698-806 MHz (spanning the frequencies where LTE bands 12, 13, and 14 were later defined) *was occupied by television broadcasters* in TV Channels 52-69. EX1045, 3. In other words, when PO filed the ’429 application on December 21, 2006 the 698-806 MHz frequency range *was not available* for use in *any* cellular communication, let alone LTE or 4G communication. Weide, ¶231.

Because the LTE frequency band definition was an “open issue” and the frequency ranges for LTE bands had not been selected, a POSA reading the ’429

application on December 21, 2006 would have concluded that the applicants did *not* possess a wireless device with an antenna configured to support an LTE frequency band (a “*frequency band[] ... used by a 4G communication standard*”) or “*configured to transmit and receive*” LTE signals (“*signals from a 4G communication standard*”), let alone one that also met the complexity factors and other requirements of the Challenged Claims. Weide, ¶232. On December 21, 2006, when the ’429 application was filed, no one could have determined whether any antenna disclosed in the application was configured to support a “*frequency band[] used by*” LTE, or to send/receive LTE signals, because the LTE frequency bands had not yet even been defined. Weide, ¶232.

A POSA would have concluded that the applicants did not possess an antenna configured to send or receive signals in the 698-806 MHz spectrum—including LTE band 12 that Fractus relies upon in litigation—for communication with any “*4G communication standard*” because those frequencies were not usable for any mobile device communications at the time of filing. Weide, ¶233. In short, the applicants did not possess, and the priority documents cannot “describe,” claimed subject matter—antennas sending and receiving signals using LTE protocols on LTE frequency bands, neither of which existed at the time. Weide, ¶233.

The '429 application thus fails to provide written description for the full scope of “*frequency band[] ... used by a 4G communication standard*” encompassing an LTE frequency band, or the full scope of “*antenna... configured to transmit and receive signals from a 4G communication standard*” that includes LTE (and LTE bands 12, 13, and 14). *Arthrex*, 35 F.4th at 1343-44; *Rivera*, 857 F.3d at 1321-22; *ICU Medical*, 558 F.3d at 1377; *Weide*, ¶234. Claims 1-20 are thus not entitled to priority to the '429 application's filing date. *Arthrex*, 35 F.4th at 1343.

A specification does not satisfy the written description requirement for a broad claim by merely describing a single embodiment. In *Smith & Nephew v. Arthrex*, IPR2017-00275, Paper 36, 27-28 (May 2, 2018), the claim recited a “first member” that covered both a flexible loop and a fixed aperture. The priority documents only disclosed a fixed aperture. The Board refused to give the claim an earlier effective-filing date because the priority documents did not provide a written description supporting the full scope of the claim including the flexible loop. *Id.*, 40; *generally id.*, 27-40. The Federal Circuit affirmed. *Arthrex*, 35 F.4th at 1343-1344.

Even if the '429 application describes a species of 4G, that is not enough to support the broad genus (antenna working with 4G communication standard) that the '200 patent claims. Written description for the 4G genus requires either (1)

“structural features common to the members” of the genus or (2) “a representative number of species falling within the scope” of the genus so that a POSA “can visualize or recognize the members” of it. *Ariad*, 598 F.3d at 1350 (internal citation omitted).

The '429 application fails both *Ariad* tests. The '200 patent claims an antenna with specific “*complexity factors*” related to the antenna’s operating frequencies, but the '429 application never teaches a POSA how to make or identify such an antenna for LTE because LTE did not exist. Based on the '429 application’s disclosure no POSA would have known how to design an LTE antenna, because in December 2006 nobody knew what frequency ranges such an antenna needed to support, or the antenna dimensions needed to support resonances for those unknown frequencies. EX1003, 25:23-26 (antenna has to support “radiation modes” for “frequency bands”); Weide, ¶235.

The '429 application’s suggestion that 4G would include bands within a 2-11 GHz frequency range (Baliarda-543, [0212]) provides no description of the 698-806 MHz frequency range that would later include LTE bands 12 to 14 (and which Fractus relies upon in litigation). Weide, ¶236. Indeed, the '429 application states that “the integration of an antenna system into the MFWD 100 is further complicated by the presence in the MFWD 100 of additional antennas... for reception of... TV[.]” Baliarda-543, [0096]. This *expressly excluded* an antenna

receiving signals at 698-806 MHz from the claimed “antenna system” because on December 21, 2006, the 698-806 MHz frequency range was allocated to television and could not be used for cellular communication. From the ’429 application’s description no POSA would have envisioned or recognized the 698-806 MHz frequency range as part of a 4G genus. Weide, ¶237.

The next application in the ’200 patent’s priority chain was U.S. Patent Application No. 14/246,491, filed April 7, 2014 as a continuation of the ’429 application. EX1003, code (63). Thus, the earliest possible effective filing date for claims 1-20 is **April 7, 2014**.

## **B. Analysis**

The published parent case Baliarda-543 (EX1040) is AIA §102(a)(1) prior art to claims 1-20 because it published January 24, 2008, more than a year before the earliest possible April 7, 2014 effective-filing date. Baliarda-543, code (43). Because Baliarda-543’s specification is materially identical to the ’200 patent, it discloses species within each Challenged Claim even though it does not disclose the full scope of each claim to a broad genus. *See Chester v. Miller*, 906 F.2d 1574, 1577 (Fed. Cir. 1990) (“no impermissible anomaly or logical inconsistency” in treating a parent application as prior art that invalidates “broader claims” it did not adequately describe); Weide, ¶¶238-240. To the extent the Board finds that

Baliarda-543 does not expressly recite any claimed subject matter, it renders such claims obvious. Weide, ¶¶241-242.

'200 claim limitation	Corresponding Disclosure in Baliarda-543
1.PRE	Abstract, [0002]
1.a	Abstract, [0082]-[0084], [0097], [0103], [0152], [0212]-[0217]
1.b	[0137], [0213]-[0215]
1.c	[0032]-[0035], [0098]-[0100], [0117]-[0118], [0212]-[0215], [0265], [0300], [0324]-[0325], Figs. 12A, 19A
1.d	<i>See</i> [1.c]; [0212]-[0215]
1.e	[0141]-[0144]
1.f	[0178], [0181]-[0183], [0213]
1.g	[0213] and [0228]-[0231]
1.h	<i>See</i> [1.c]; [0212]-[0215]
2	[0114]-[0116], [0133]-[0134], [0154]-[0162], [0213], [0226]-[0227], Fig. 1B
3	[0141]-[0144], [0149]-[0151], [0271]
4	<i>See</i> [1.c]
5	<i>See</i> [1.c]
6.PRE	<i>See</i> [1.PRE]
6.a	<i>See</i> [1.a]
6.b	<i>See</i> [1.c] and [1.d]
6.c	<i>See</i> [1.c]

<b>'200 claim limitation</b>	<b>Corresponding Disclosure in Baliarda-543</b>
6.d	<i>See</i> [1.e]
6.e	<i>See</i> [1.f]
6.f	<i>See</i> [1.g] and [1.h]
6.g	<i>See</i> claim 2
6.h	<i>See</i> [1.b] and [1.g]
7	[0141]-[0149], [0270], Fig. 12A
8	<i>See</i> [1.g]
9	<i>See</i> claim 3
10	[0103], [0212]-[0215]
11.PRE	<i>See</i> [1.PRE]
11.a	<i>See</i> [1.a]
11.b	<i>See</i> [1.c] and [1.d]
11.c	<i>See</i> [1.e]
11.d	<i>See</i> claim 7
11.e	<i>See</i> [1.f]
11.f	<i>See</i> claim 2
11.g	<i>See</i> [1.h]
11.h	<i>See</i> [1.g]
12	<i>See</i> [1.c]
13	<i>See</i> [1.c]
14	<i>See</i> [1.c]

'200 claim limitation	Corresponding Disclosure in Baliarda-543
15	<i>See claim 10</i>
16	<i>See claim 10</i>
17	<i>See claim 10</i>
18	<i>See claim 10 and [0032]-[0035], [0099] and [0212]</i>
19	<i>See claim 10</i>
20	<i>See claim 10</i>

For Limitations [2], [6.g] and [11.f], Baliarda-543 at [0154]-[0162] says that the  $G_2$  grid and the  $G_2$  cell aspect ratio are determined based on the aspect ratio of the antenna rectangle. This describes a 9 column by  $(2n + 1)$  row  $G_2$  grid of cells—e.g., having an odd number  $(2n + 1)$  of rows where  $n$  is an integer between 0 and 5 (for 1 to 11 rows)—wherein the aspect ratio of the cells is as close to 1 as possible. Baliarda-543 therefore describes an antenna rectangle wherein the  $G_2$  grid has 9 columns by 1 row or 3 rows, with each cell as square as possible, which means that Baliarda-543 separately describes an antenna rectangle with an aspect ratio on the order of 9 or 3, e.g., more than 2 as recited in [2], [6.g] and [11.f]. Weide, ¶243.

### VIII. *SOTERA*

Petitioners stipulate that if IPR is instituted on this Petition they will not pursue, in the Texas Litigation, any ground raised or that reasonably could have

been raised in IPR. *Sotera Wireless v. Masimo*, IPR2020-01019, Paper 12, 18-19 (Dec. 1, 2020) (precedential as to §II.A).

## **IX. DISCRETIONARY DENIAL IS UNWARRANTED**

There is no basis for discretionary denial. Petitioners rely on the Director’s March 26, 2025 Memorandum concerning Interim Processes for PTAB Workload Management<sup>8</sup> and the Board’s guidance concerning “the new interim processes relating to institution in AIA proceedings”<sup>9</sup> wherein “the Director... will determine whether discretionary denial of institution is appropriate” in separate briefing filed after a Notice of Filing Date Accorded.

Petitioners reserve the right to respond to any Patent Owner discretionary denial arguments in opposition briefing under the March 26, 2025 Interim Process.

---

<sup>8</sup> Available at <https://www.uspto.gov/sites/default/files/documents/InterimProcesses-PTABWorkloadMgmt-20250326.pdf> (visited April 30, 2025).

<sup>9</sup> FAQ, available at <https://www.uspto.gov/patents/ptab/faqs/interim-processes-workload-management> (visited April 30, 2025); USPTO Boardside Chat (Apr. 17, 2025), available at <https://www.uspto.gov/about-us/events/learn-about-new-interim-processes-relating-institution-aia-proceedings> (visited April 30, 2025).

**X. CONCLUSION**

The Board should institute review and cancel claims 1-20.

Respectfully submitted,  
*Geotab Inc. and Geotab USA, Inc.*

Dated: June 6, 2025 By: /Adam R. Wichman/  
Adam R. Wichman, Reg. No. 43,988  
WOLF, GREENFIELD & SACKS, P.C.

**APPENDIX A: U.S. PATENT NO. 11,349,200 CLAIM LIST**

<b>REF</b>	<b>Limitation</b>
1.PRE	A wireless device comprising:
1.a	an antenna system comprising a ground plane and at least two antennas within the wireless device, the antenna system comprising:
1.b	a first antenna proximate to a first short side of a ground plane rectangle enclosing the ground plane,
1.c	the first antenna being configured to support at least three frequency bands contained within first and second frequency ranges of the electromagnetic spectrum, the second frequency range being higher in frequency than the first frequency range,
1.d	the first antenna being configured to transmit and receive signals from a 4G communication standard,
1.e	the first antenna defining a first antenna contour comprising an entire perimeter of the first antenna,
1.f	wherein the first antenna contour has a level of complexity defined by complexity factor $F_{21}$ having a value of at least 1.20 and complexity factor $F_{32}$ having a value of at least 1.35; and
1.g	a second antenna proximate to a first long side of the ground plane rectangle,
1.h	and wherein the second antenna is configured to receive signals from a 4G communication standard.

REF	Limitation
2	The wireless device of claim 1, wherein the second antenna defines an antenna box that is a minimum-sized parallelepiped that completely encloses a volume of the second antenna and wherein each face of the minimum-sized parallelepiped is tangent to at least one point of the volume of the second antenna, an orthogonal projection of the antenna box along a normal to a face with a largest area of the second antenna defining an antenna rectangle, an aspect ratio of the antenna rectangle being defined as a ratio between a width and a height of the antenna rectangle, and wherein the aspect ratio has a value of at least 2.
3	The wireless device of claim 2, wherein the second antenna defines a second antenna contour comprising an entire perimeter of the second antenna, wherein a length of the second antenna contour is greater than four times a diagonal of the antenna rectangle.
4	The wireless device of claim 1, wherein the first antenna is configured to support at least four frequency bands.
5	The wireless device of claim 1, wherein the first antenna is configured to support at least five frequency bands.
6.PRE	A wireless device comprising:
6.a	an antenna system comprising a ground plane and at least two antennas within the wireless device, the antenna system comprising:
6.b	a first antenna configured to provide operation in at least four frequency bands being used by 4G communication standards,

REF	Limitation
6.c	wherein at least two of the at least four frequency bands are contained within a first frequency range and at least two of the four frequency bands are contained within a second frequency range, the first frequency range being lower in frequency than the second frequency range,
6.d	the first antenna defining a first antenna contour comprising an entire perimeter of the first antenna, and
6.e	wherein the first antenna contour has a level of complexity defined by complexity factor $F_{21}$ having a value of at least 1.20 and complexity factor $F_{32}$ having a value of at least 1.35; and
6.f	a second antenna configured to operate in at least one frequency band being used by a 4G communication standard,
6.g	the second antenna defining an antenna box that is a minimum-sized parallelepiped that completely encloses a volume of the second antenna and wherein each face of the minimum-sized parallelepiped is tangent to at least one point of the volume of the second antenna, an orthogonal projection of the antenna box along a normal to a face with a largest area of the second antenna defining an antenna rectangle, an aspect ratio of the antenna rectangle being defined as a ratio between a width and a height of the antenna rectangle, and wherein the aspect ratio has a value of at least 2,
6.h	and wherein at least one of the first and second antennas is close to a first short side of a ground plane rectangle enclosing the ground plane.
7	The wireless device of claim 6, wherein the first antenna contour comprises at least 20 segments.

REF	Limitation
8	The wireless device of claim 6, wherein at least one of the first and second antennas is close to a first long side of the ground plane rectangle.
9	The wireless device of claim 6, wherein the second antenna defines a second antenna contour comprising an entire perimeter of the second antenna, wherein a length of the second antenna contour is greater than four times a diagonal of the antenna rectangle.
10	The wireless device of claim 6, wherein the antenna system comprises a third antenna configured to provide operation in a wireless communication standard.
11.PRE	A wireless device comprising:
11.a	an antenna system comprising a ground plane and at least two antennas within the wireless device, the antenna system comprising:
11.b	a first antenna configured to provide operation in at least three frequency bands being used by 4G communication standards,
11.c	the first antenna defining an antenna contour comprising an entire perimeter of the first antenna,
11.d	the antenna contour comprising at least twenty segments,
11.e	wherein the antenna contour has a level of complexity defined by complexity factor $F_{21}$ having a value of at least 1.20 and complexity factor $F_{32}$ having a value of at least 1.35,

REF	Limitation
11.f	and wherein the first antenna defines an antenna box that is a minimum-sized parallelepiped that completely encloses a volume of the first antenna and wherein each face of the minimum-sized parallelepiped is tangent to at least one point of the volume of the first antenna, an orthogonal projection of the antenna box along a normal to a face with a largest area of the first antenna defining an antenna rectangle, an aspect ratio of the antenna rectangle being defined as a ratio between a width and a height of the antenna rectangle, wherein the aspect ratio has a value of at least 2; and
11.g	a second antenna configured to provide operation in a first wireless service,
11.h	the second antenna being proximate to a side of a ground plane rectangle enclosing the ground plane.
12	The wireless device of claim 11, wherein the first antenna is configured to support at least four frequency bands.
13	The wireless device of claim 11, wherein the first wireless service is a WiFi communication standard.
14	The wireless device of claim 13, wherein the first wireless service provides operation in the 2400-2480 MHz frequency range and the 5.1-5.9 GHz frequency range.
15	The wireless device of claim 11, wherein the antenna system comprises a third antenna.
16	The wireless device of claim 15, wherein the third antenna is configured to provide operation in the first wireless service.

<b>REF</b>	<b>Limitation</b>
17	The wireless device of claim 15, wherein the third antenna is configured to provide operation in a second wireless service.
18	The wireless device of claim 17, wherein the second wireless service provides operation in the 902-928 MHz frequency range.
19	The wireless device of claim 15, wherein the antenna system comprises a fourth antenna.
20	The wireless device of claim 19, wherein the fourth antenna is configured to provide operation in a third wireless service.

## CERTIFICATE OF WORD COUNT

Pursuant to 37 C.F.R. § 42.24, the undersigned certifies that the foregoing Petition for *Inter Partes* Review contains 12,528 words excluding a table of contents, a table of authorities, Mandatory Notices under § 42.8, a certificate of service or word count, or appendix of exhibits or claim listing. Petitioner has relied on the word count feature of the word processing system used to create this paper in making this certification.

Date: June 6, 2025

/Dara Del Rosario/  
Dara Del Rosario  
Paralegal Name  
WOLF, GREENFIELD & SACKS, P.C.

**CERTIFICATE OF SERVICE UNDER 37 C.F.R. §§ 42.6(E)(4), 42.55(A)**

I certify that on June 6, 2025, a copy of a redacted version of the foregoing document, including any public redacted exhibits or appendices filed therewith, is being served via *Overnight FedEx* at the following correspondence address of record for the patent:

EDELL, SHAPIRO & FINNAN, LLC  
9801 Washingtonian Blvd.  
Suite 750  
Gaithersburg, MD 20878

Date: June 6, 2025

/Dara Del Rosario/  
Dara Del Rosario  
Paralegal  
WOLF, GREENFIELD & SACKS, P.C.