

# VisionTrack VT3500-AI

Infringement where the main antenna is considered the first antenna

\* The photos used for the **VisionTrack VT3500-AI** correspond to the **Streamax AD Plus**, since both devices have the same architecture and same antenna geometries.

**CONFIDENTIAL**

# US 11,349,200 - VisionTrack VT3500-AI

## Claim 6

[6-preamble] A wireless device comprising [6a] an antenna system comprising [6b] a ground plane and [6c] at least two antennas within the wireless device, the antenna system comprising:

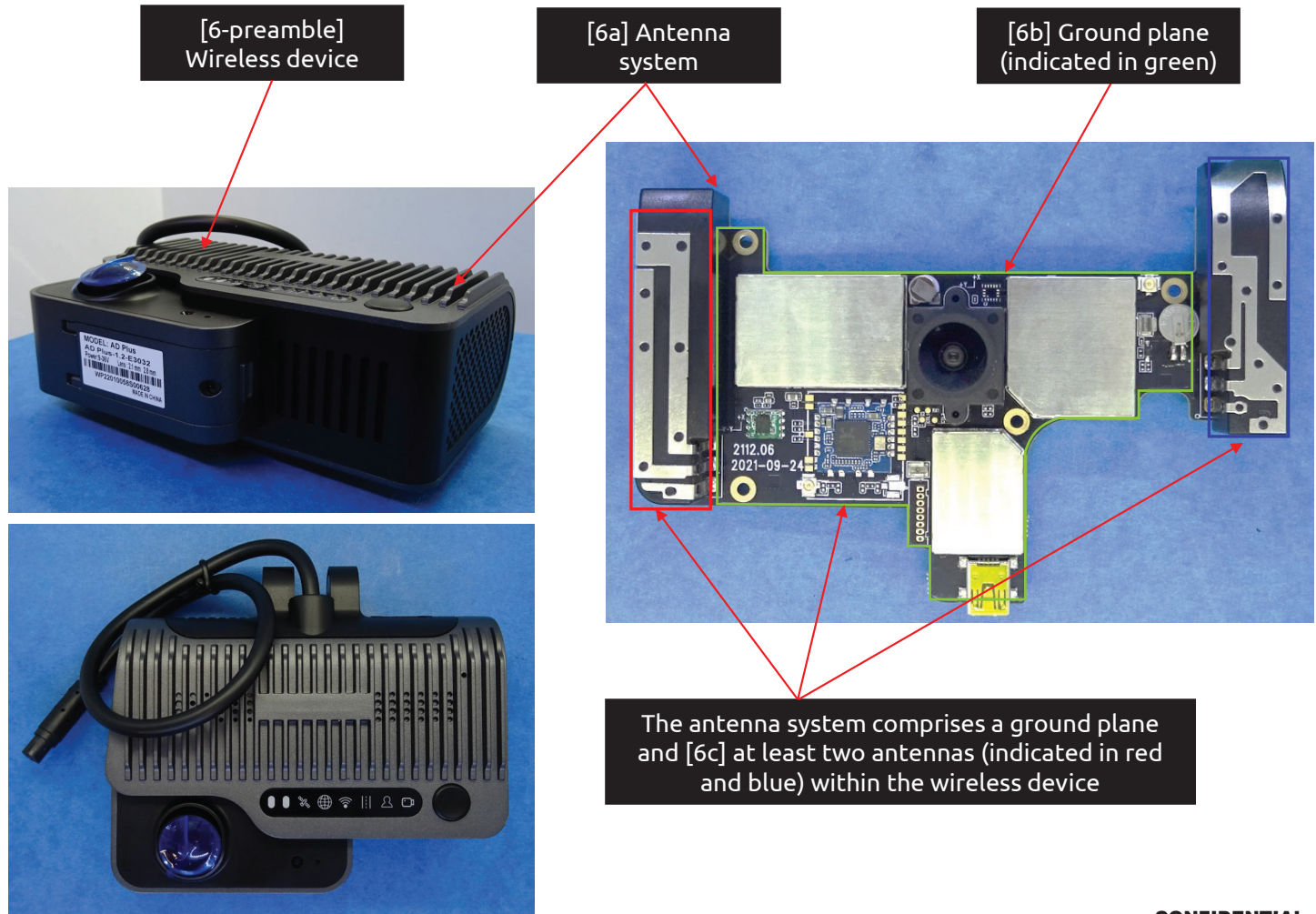

CONFIDENTIAL

# US 11,349,200 - VisionTrack VT3500-AI

## Claim 6

[6d] a first antenna configured to provide operation in at least four frequency bands being used by 4G communication standards, wherein

Antenna system

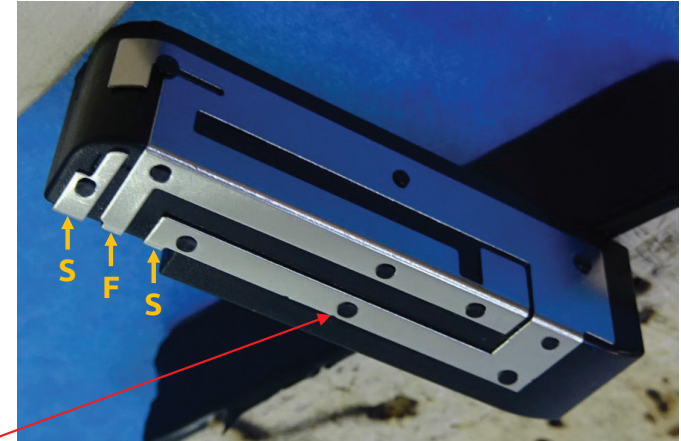
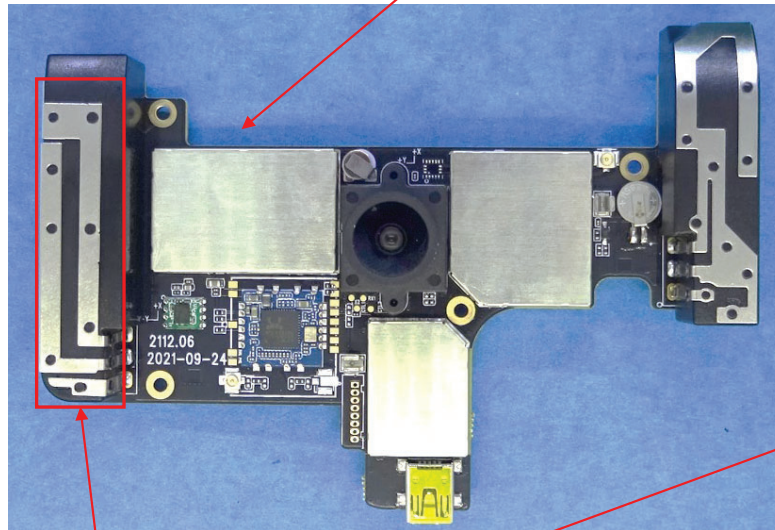

[6d] The antenna system comprises a first antenna (indicated in red) configured to provide operation in at least LTE 700(B12)/850(B5)/1700-2100(B4)/1900(B2)

	Mode
LTE Band 12	WCDMA Band 2
LTE Band 13	WCDMA Band 5
LTE Band 14	LTE Band 2
LTE Band 66	LTE Band 4
LTE Band 71	LTE Band 5

Source: RF Test Report

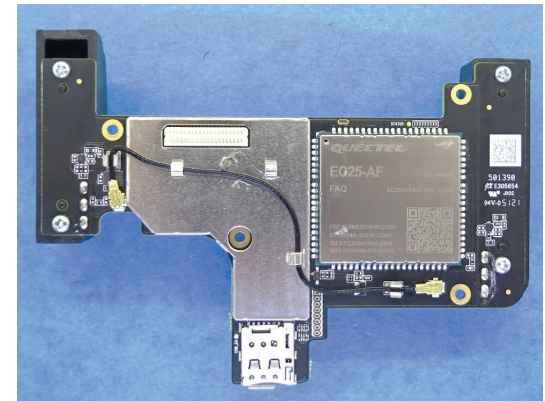

**CONFIDENTIAL**

# US 11,349,200 - VisionTrack VT3500-AI

## Claim 6

[6e] at least two of the at least four frequency bands are contained within a first frequency range and [6f] at least two of the at least four frequency bands are contained within a second frequency range, [6g] the first frequency range being lower in frequency than the second frequency range,

[6e] At least two of the at least four frequency bands are contained within a first frequency range (filled in red) and [6f] at least two of the at least four frequency bands are contained within a second frequency range (filled in blue)

Mode	
LTE Band 12	WCDMA Band 2
LTE Band 13	WCDMA Band 5
LTE Band 14	LTE Band 2
LTE Band 66	LTE Band 4
LTE Band 71	LTE Band 5

Source: RF Test Report

[6g] The first frequency range being lower in frequency than the second frequency range

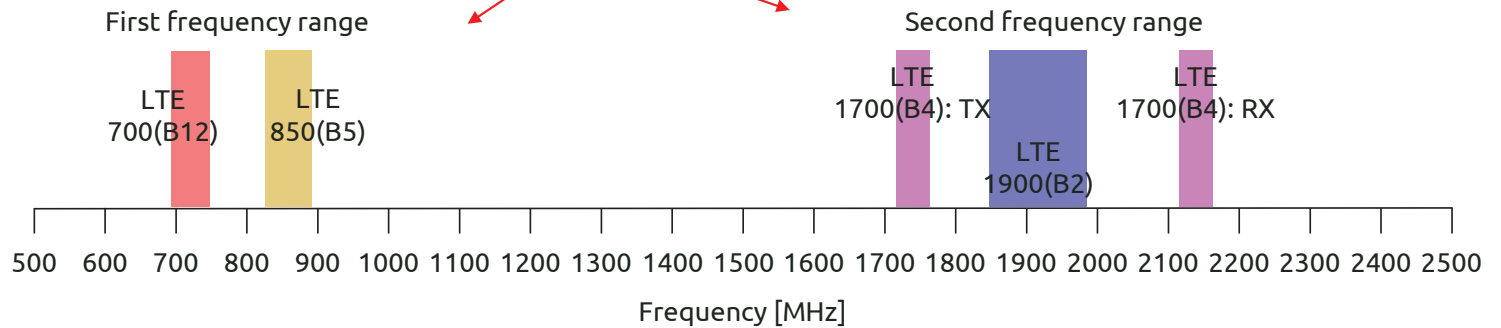

CONFIDENTIAL

## US 11,349,200 - VisionTrack VT3500-AI

### Claim 6

[6h] the first antenna defining a first antenna contour comprising an entire perimeter of the first antenna, and

[6h] The first antenna defines a first antenna contour (indicated in blue and red) comprising an entire perimeter of the first antenna

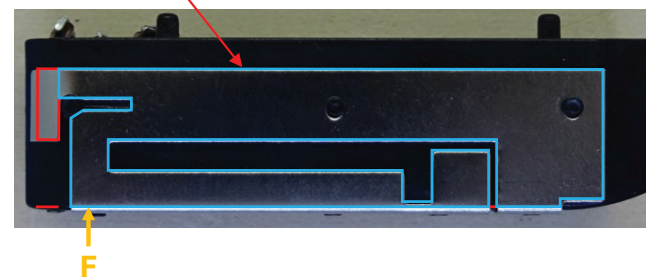
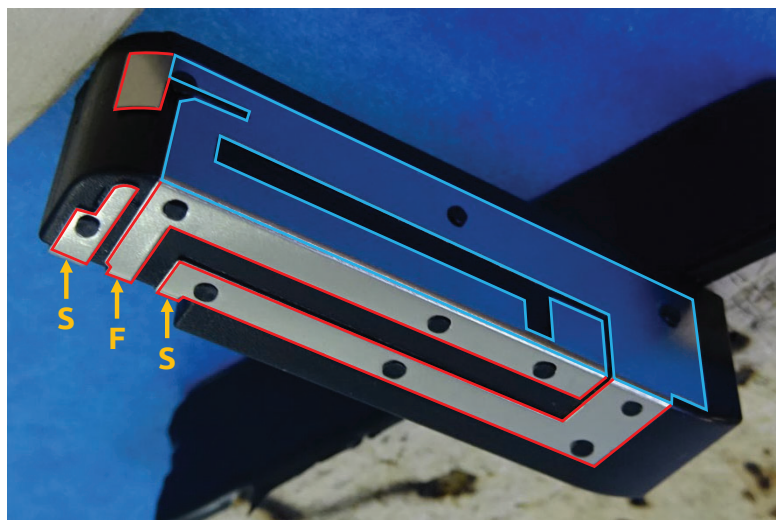

CONFIDENTIAL

# US 11,349,200 - VisionTrack VT3500-AI

## Claim 6

[6i] wherein the first antenna contour has a level of complexity defined by complexity factor  $F_{21}$  having a value of at least 1.20 and

[6i] The first antenna contour has a level of complexity defined by complexity factor  $F_{21}$  having a value of at least 1.20

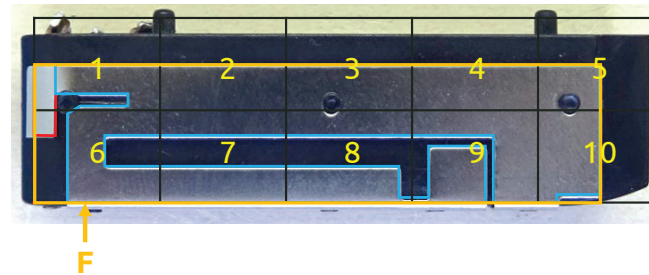

$$F_{21} = -\frac{\log(N_2) - \log(N_1)}{\log\left(\frac{1}{2}\right)} = -\frac{\log(27) - \log(10)}{\log\left(\frac{1}{2}\right)} = 1.43 \geq 1.20$$



CONFIDENTIAL

# US 11,349,200 - VisionTrack VT3500-AI

## Claim 6

[6j] complexity factor  $F_{32}$  having a value of at least 1.35; and

[6j] The first antenna contour has a level of complexity defined by complexity factor  $F_{32}$  having a value of at least 1.35

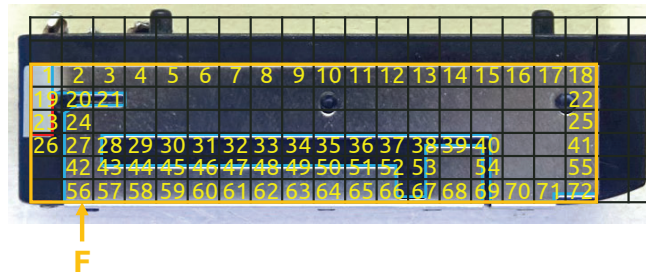

$N_3 = 72$  cells

$$F_{32} = -\frac{\log(N_3) - \log(N_2)}{\log\left(\frac{1}{2}\right)} = -\frac{\log(72) - \log(27)}{\log\left(\frac{1}{2}\right)} = 1.41 \geq 1.35$$

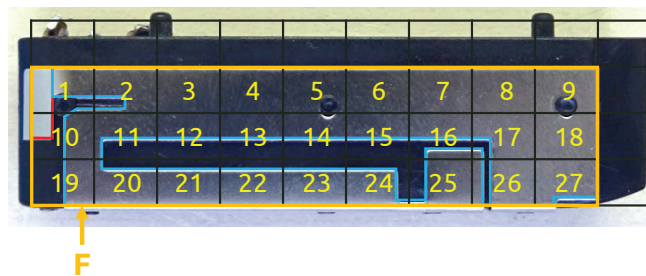

$N_2 = 27$  cells

CONFIDENTIAL

# US 11,349,200 - VisionTrack VT3500-AI

## Claim 6

[6k] a second antenna configured to operate in at least one frequency band being used by a 4G communication standard,

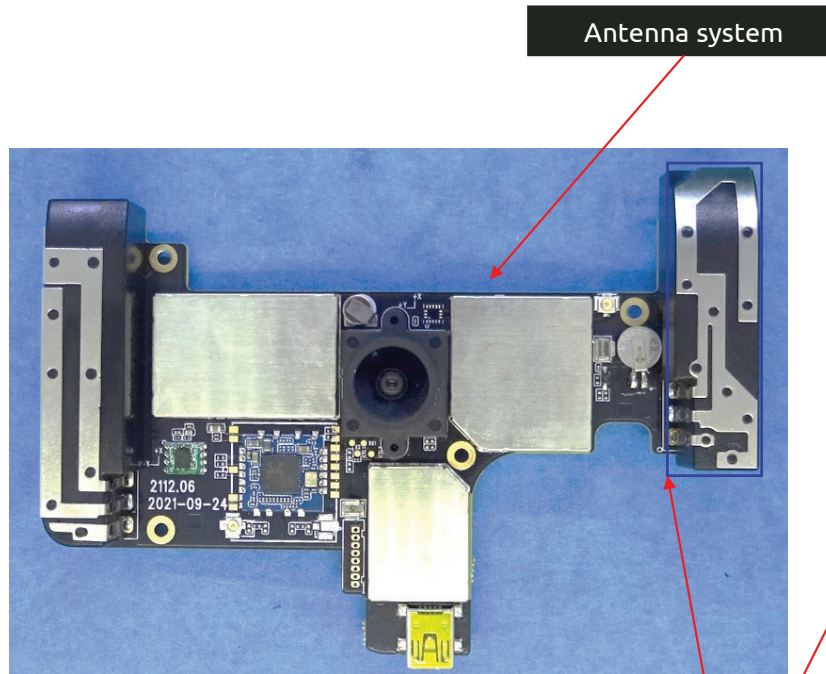

Mode	
LTE Band 12	WCDMA Band 2
LTE Band 13	WCDMA Band 5
LTE Band 14	LTE Band 2
LTE Band 66	LTE Band 4
LTE Band 71	LTE Band 5

Source: RF Test Report

[6k] The antenna system comprises a second antenna (indicated in blue) configured to operate in at least LTE 700(B12)

**CONFIDENTIAL**

## US 11,349,200 - VisionTrack VT3500-AI

### Claim 6

[6l] the second antenna defining an antenna box that is a minimum-sized parallelepiped that completely encloses a volume of the second antenna and [6m] wherein each face of the minimum-sized parallelepiped is tangent to at least one point of the volume of the second antenna,

[6l] The second antenna defines an antenna box (outlined in pink) that is a minimum-sized parallelepiped that completely encloses a volume of the second antenna



[6m] Each face of the minimum-sized parallelepiped is tangent to at least one point of the volume of the second antenna

**CONFIDENTIAL**

## US 11,349,200 - VisionTrack VT3500-AI

### Claim 6

[6n] an orthogonal projection of the antenna box along a normal to a face with a largest area of the second antenna defining  
[6o] an antenna rectangle,

[6o] Antenna rectangle  
(filled in green)

[6n] An orthogonal projection of the antenna box along a normal to a face\* with a largest area of the second antenna

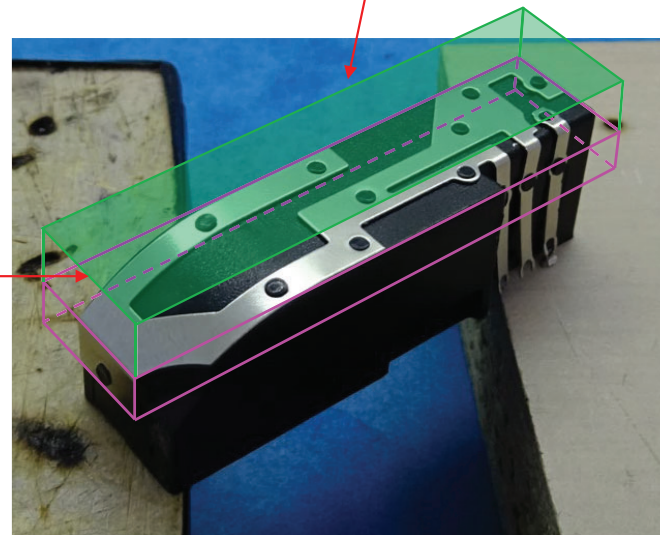

\*Normal to a face means perpendicular to the face

**CONFIDENTIAL**

## US 11,349,200 - VisionTrack VT3500-AI

### Claim 6

[6p] an aspect ratio of the antenna rectangle being defined as a ratio between a width and a height of the antenna rectangle, and wherein the aspect ratio has a value of at least 2, and

[6p] Aspect ratio of the antenna rectangle being defined as a ratio between a width and a height of the antenna rectangle, and wherein the aspect ratio has a value of  $46.4/12 = 3.9 \geq 2$

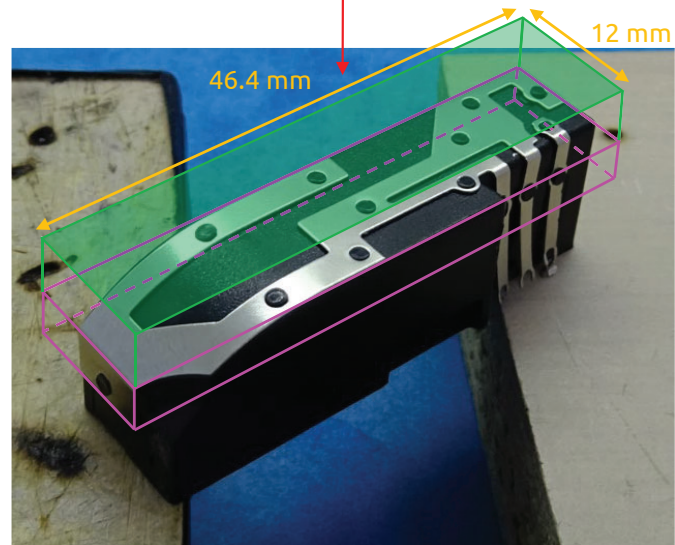

CONFIDENTIAL

## US 11,349,200 - VisionTrack VT3500-AI

### Claim 6

[6q] wherein at least one of the first and second antennas is close to a first short side of a ground plane rectangle enclosing the ground plane.

[6q] At least the first antenna is close to a first short side of a ground plane rectangle (indicated with a dashed green line) enclosing the ground plane

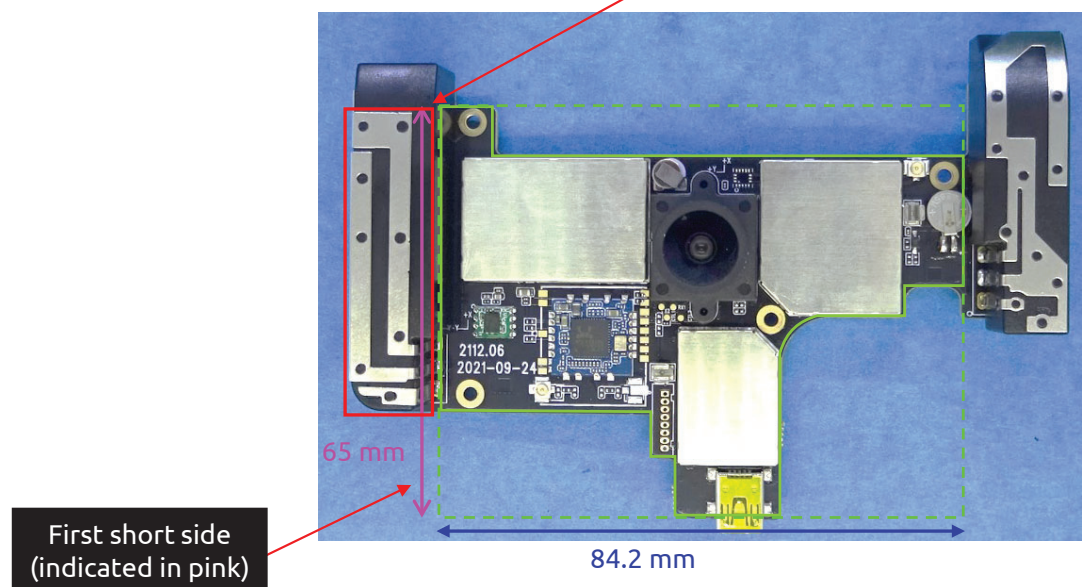

CONFIDENTIAL

# US 11,349,200 - VisionTrack VT3500-AI

## Claim 7

[7a] The wireless device of claim 6, wherein the first antenna contour comprises at least 20 segments.

[7a] The first antenna contour (indicated in blue and red) comprises at least 20 segments

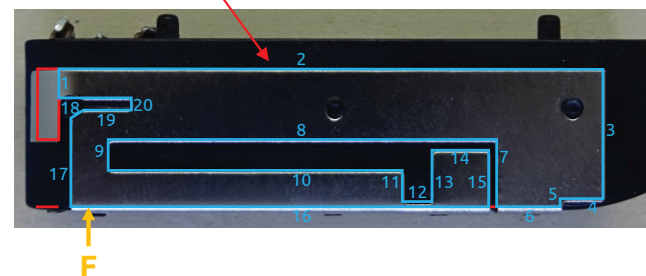
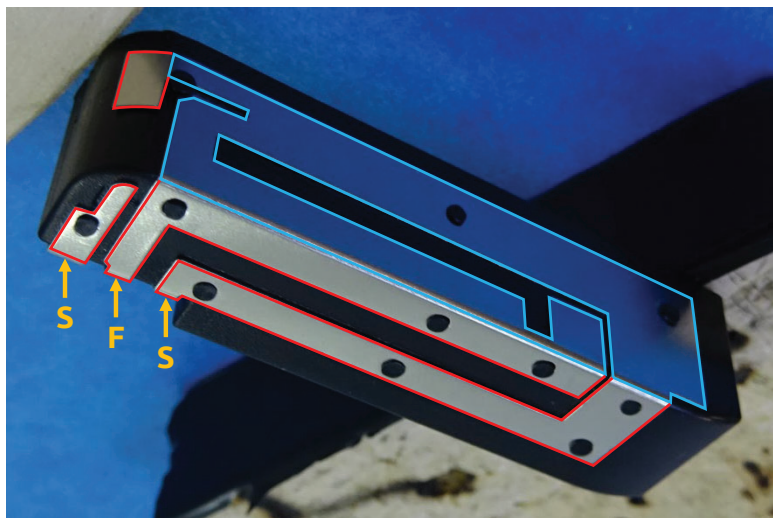

CONFIDENTIAL

## US 11,349,200 - VisionTrack VT3500-AI

### Claim 9

[9a] The wireless device of claim 6, wherein the second antenna defines a second antenna contour comprising an entire perimeter of the second antenna,

[9a] The second antenna defines a second antenna contour (indicated in blue and red) comprising an entire perimeter of the second antenna

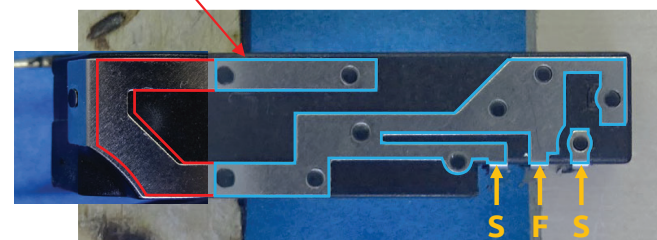

CONFIDENTIAL

# US 11,349,200 - VisionTrack VT3500-AI

## Claim 9

[9b] wherein a length of the second antenna contour is greater than four times a diagonal of the antenna rectangle.

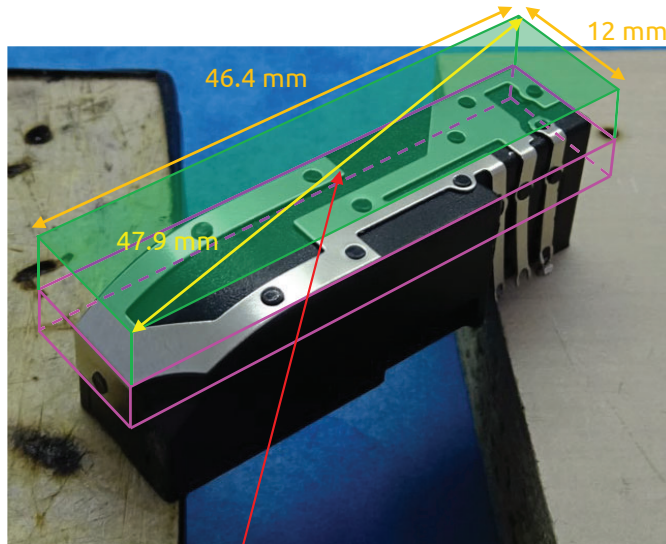

Diagonal of the antenna rectangle = 47.9 mm

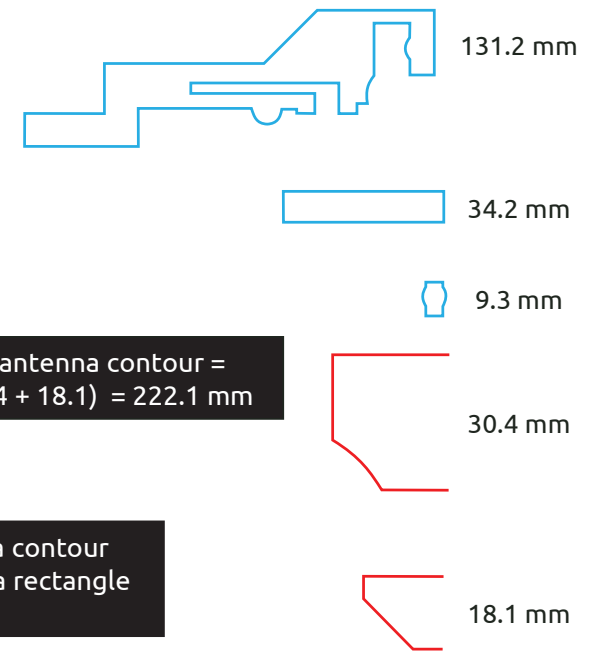
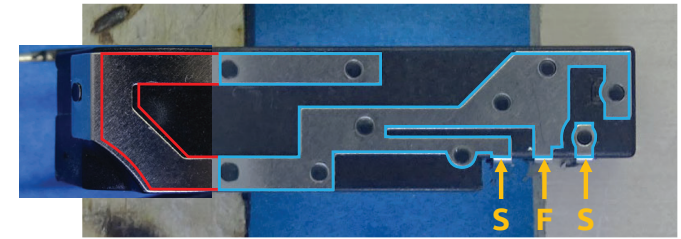

Length of the second antenna contour =  $(131.2 + 34.2 + 9.3 + 30.4 + 18.1) = 222.1$  mm

[9b] The length of the second antenna contour (222.1 mm) > 4\*Diagonal of the antenna rectangle (4\*47.9 = 191.6 mm)

**CONFIDENTIAL**

# US 11,349,200 - VisionTrack VT3500-AI

## Claim 10

[10a] The wireless device of claim 6, wherein the antenna system comprises a third antenna configured to provide operation in a wireless communication standard.

[10a] The antenna system comprises a third antenna (indicated in yellow) configured to provide operation in at least a wireless communication standard: WiFi

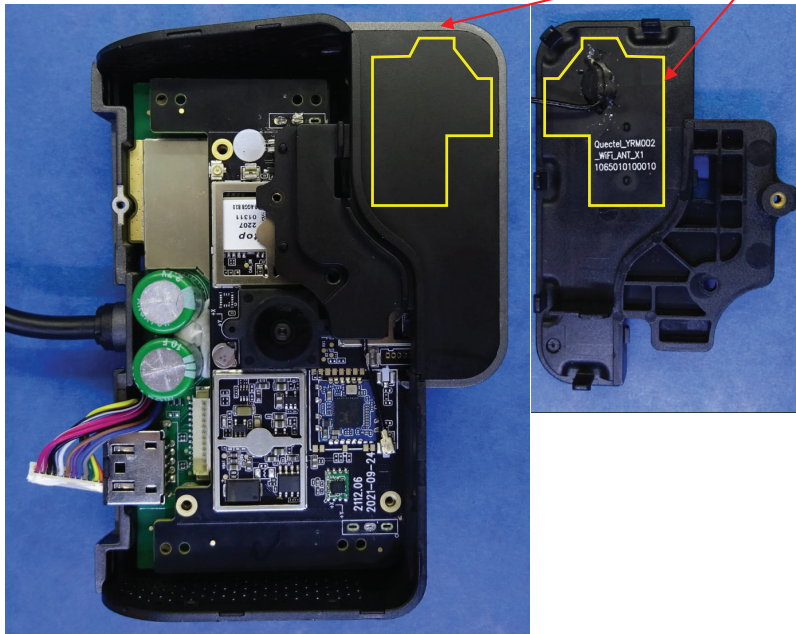

Mode
2.4G WiFi
5.8G WIFI

Source: RF Test Report

CONFIDENTIAL

# VisionTrack VT3500-AI

## Infringement where the diversity antenna is considered the first antenna

\* The photos used for the **VisionTrack VT3500-AI** correspond to the **Streamax AD Plus**, since both devices have the same architecture and same antenna geometries.

**CONFIDENTIAL**

# US 11,349,200 - VisionTrack VT3500-AI

## Claim 6

[6-preamble] A wireless device comprising [6a] an antenna system comprising [6b] a ground plane and [6c] at least two antennas within the wireless device, the antenna system comprising:

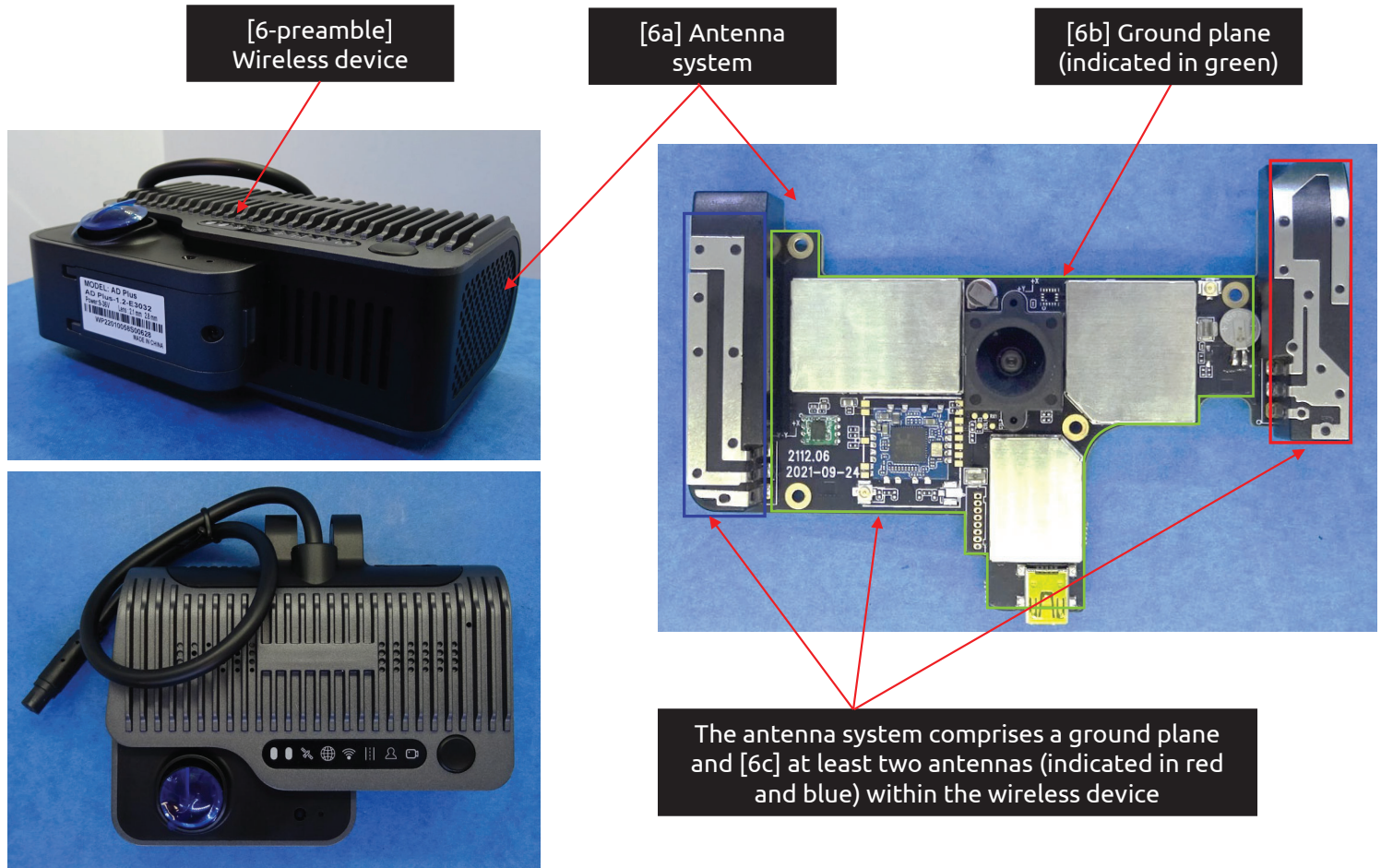

CONFIDENTIAL

# US 11,349,200 - VisionTrack VT3500-AI

## Claim 6

[6d] a first antenna configured to provide operation in at least four frequency bands being used by 4G communication standards, wherein

Antenna system

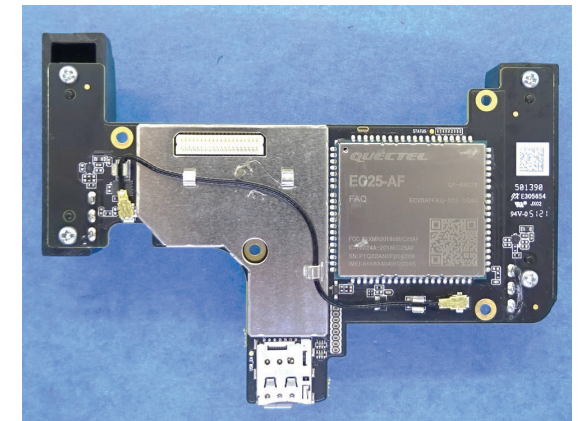
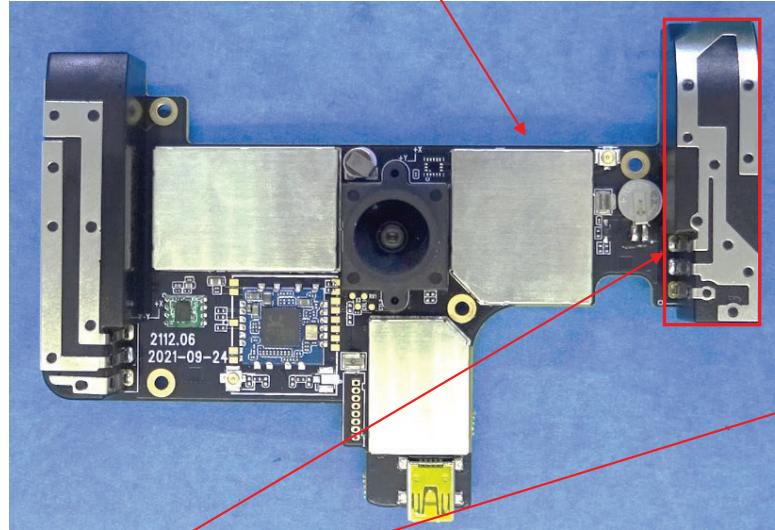

[6d] The antenna system comprises a first antenna (indicated in red) configured to provide operation in at least LTE 700(B12)/850(B5)/2100(B4)/1900(B2)

Mode

LTE Band 12	WCDMA Band 2
LTE Band 13	WCDMA Band 5
LTE Band 14	LTE Band 2
LTE Band 66	LTE Band 4
LTE Band 71	LTE Band 5

Source: RF Test Report

**CONFIDENTIAL**

# US 11,349,200 - VisionTrack VT3500-AI

## Claim 6

[6e] at least two of the at least four frequency bands are contained within a first frequency range and [6f] at least two of the at least four frequency bands are contained within a second frequency range, [6g] the first frequency range being lower in frequency than the second frequency range,

[6e] At least two of the at least four frequency bands are contained within a first frequency range (filled in red) and [6f] at least two of the at least four frequency bands are contained within a second frequency range (filled in blue)

Mode	
LTE Band 12	WCDMA Band 2
LTE Band 13	WCDMA Band 5
LTE Band 14	LTE Band 2
LTE Band 66	LTE Band 4
LTE Band 71	LTE Band 5

Source: RF Test Report

[6g] The first frequency range being lower in frequency than the second frequency range

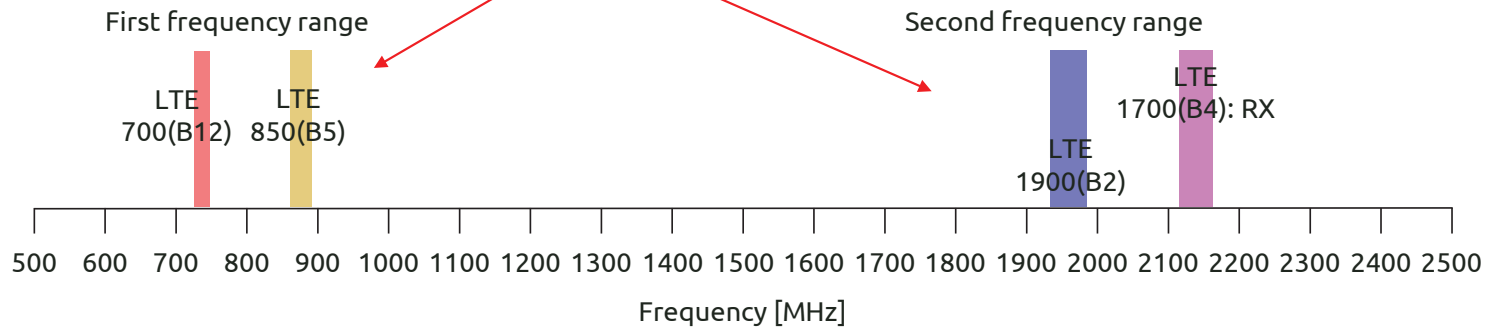

CONFIDENTIAL

# US 11,349,200 - VisionTrack VT3500-AI

## Claim 6

[6h] the first antenna defining a first antenna contour comprising an entire perimeter of the first antenna, and

[6h] The first antenna defines a first antenna contour (indicated in blue and red) comprising an entire perimeter of the first antenna

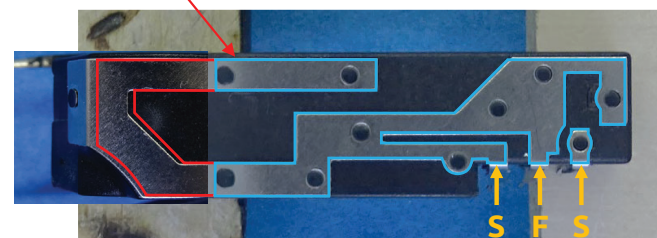

CONFIDENTIAL

# US 11,349,200 - VisionTrack VT3500-AI

## Claim 6

[6i] wherein the first antenna contour has a level of complexity defined by complexity factor  $F_{21}$  having a value of at least 1.20 and

[6i] The first antenna contour has a level of complexity defined by complexity factor  $F_{21}$  having a value of at least 1.20

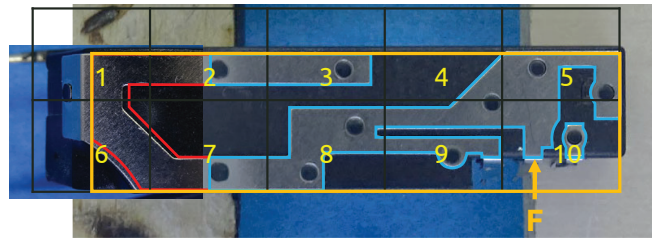

$N_1 = 10 \text{ cells}$

$$F_{21} = -\frac{\log(N_2) - \log(N_1)}{\log(1/2)} = -\frac{\log(25) - \log(10)}{\log(1/2)} = 1.32 \geq 1.20$$

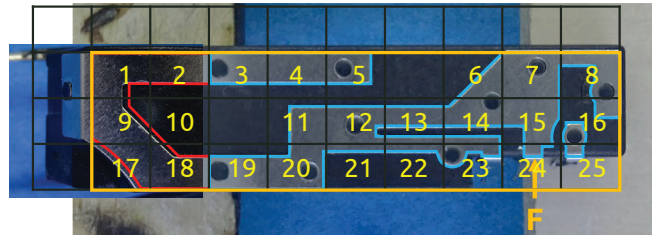

$N_2 = 25 \text{ cells}$

CONFIDENTIAL

# US 11,349,200 - VisionTrack VT3500-AI

## Claim 6

[6j] complexity factor  $F_{32}$  having a value of at least 1.35; and

[6j] The first antenna contour has a level of complexity defined by complexity factor  $F_{32}$  having a value of at least 1.35

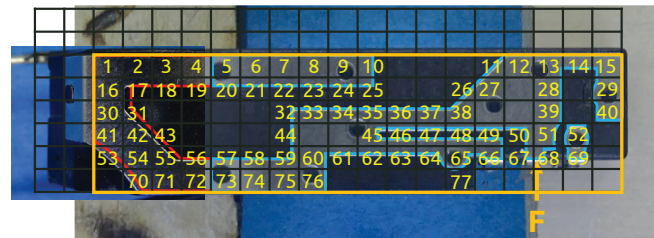

$N_3 = 77$  cells

$$F_{32} = -\frac{\log(N_3) - \log(N_2)}{\log\left(\frac{1}{2}\right)} = -\frac{\log(77) - \log(25)}{\log\left(\frac{1}{2}\right)} = 1.62 \geq 1.35$$

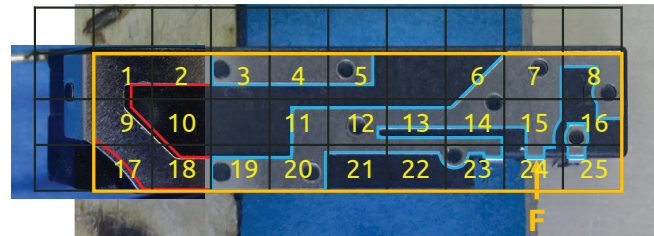

$N_2 = 25$  cells

CONFIDENTIAL

# US 11,349,200 - VisionTrack VT3500-AI

## Claim 6

[6k] a second antenna configured to operate in at least one frequency band being used by a 4G communication standard,

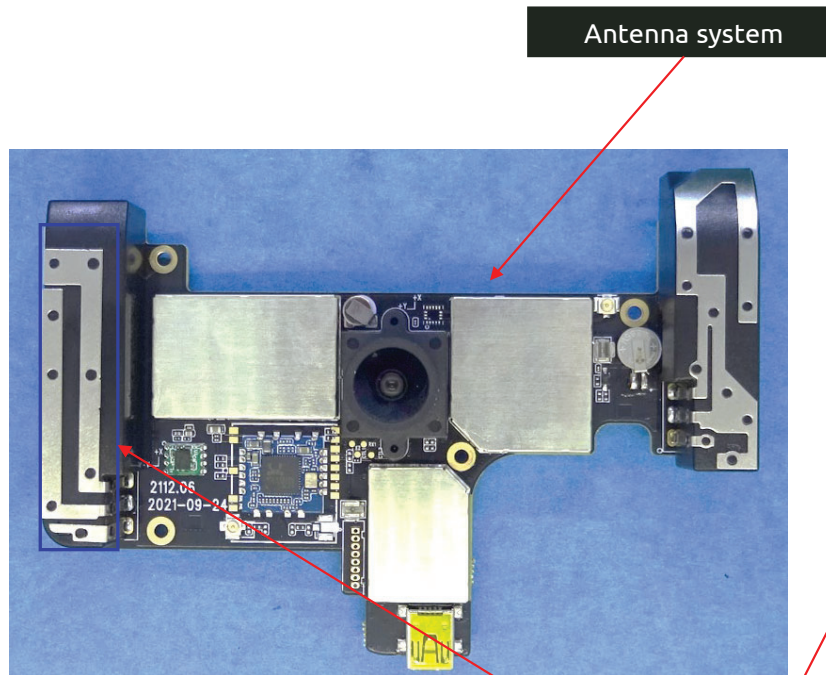

Mode	
LTE Band 12	WCDMA Band 2
LTE Band 13	WCDMA Band 5
LTE Band 14	LTE Band 2
LTE Band 66	LTE Band 4
LTE Band 71	LTE Band 5

Source: RF Test Report

[6k] The antenna system comprises a second antenna (indicated in blue) configured to operate in at least LTE 700(B12)

CONFIDENTIAL

## US 11,349,200 - VisionTrack VT3500-AI

### Claim 6

[6l] the second antenna defining an antenna box that is a minimum-sized parallelepiped that completely encloses a volume of the second antenna and [6m] wherein each face of the minimum-sized parallelepiped is tangent to at least one point of the volume of the second antenna,

[6l] The second antenna defines an antenna box (outlined in pink) that is a minimum-sized parallelepiped that completely encloses a volume of the second antenna

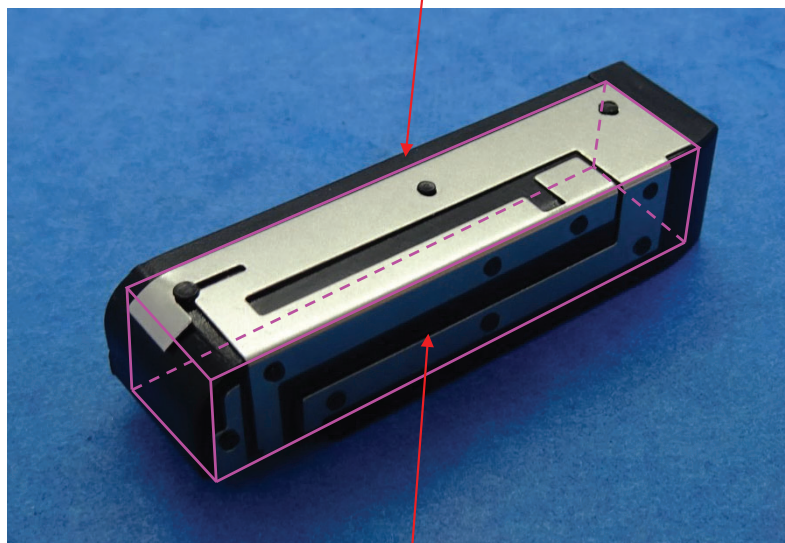

[6m] Each face of the minimum-sized parallelepiped is tangent to at least one point of the volume of the second antenna

**CONFIDENTIAL**

## US 11,349,200 - VisionTrack VT3500-AI

### Claim 6

[6n] an orthogonal projection of the antenna box along a normal to a face with a largest area of the second antenna defining  
[6o] an antenna rectangle,

[6n] An orthogonal projection of the antenna box along a normal to a face\* with a largest area of the second antenna

[6o] Antenna rectangle  
(filled in green)

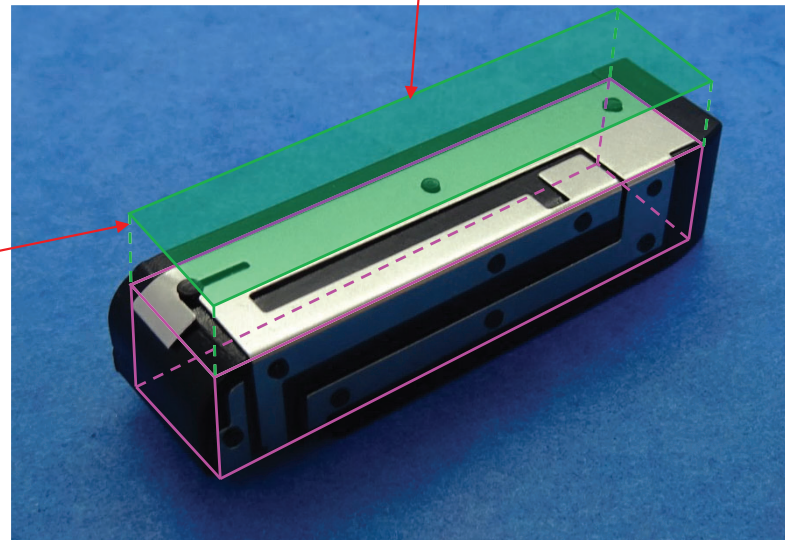

\*Normal to a face means perpendicular to the face

**CONFIDENTIAL**

## US 11,349,200 - VisionTrack VT3500-AI

### Claim 6

[6p] an aspect ratio of the antenna rectangle being defined as a ratio between a width and a height of the antenna rectangle, and wherein the aspect ratio has a value of at least 2, and

[6p] Aspect ratio of the antenna rectangle being defined as a ratio between a width and a height of the antenna rectangle, and wherein the aspect ratio has a value of  $48.4/11.5 = 4.2 \geq 2$

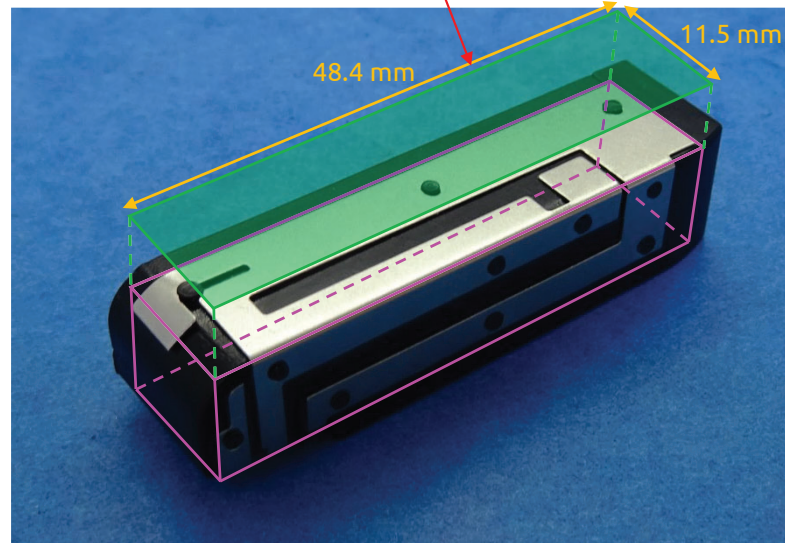

CONFIDENTIAL

# US 11,349,200 - VisionTrack VT3500-AI

## Claim 6

[6q] wherein at least one of the first and second antennas is close to a first short side of a ground plane rectangle enclosing the ground plane.

[6q] At least the first antenna is close to a first short side of a ground plane rectangle (indicated with a dashed green line) enclosing the ground plane

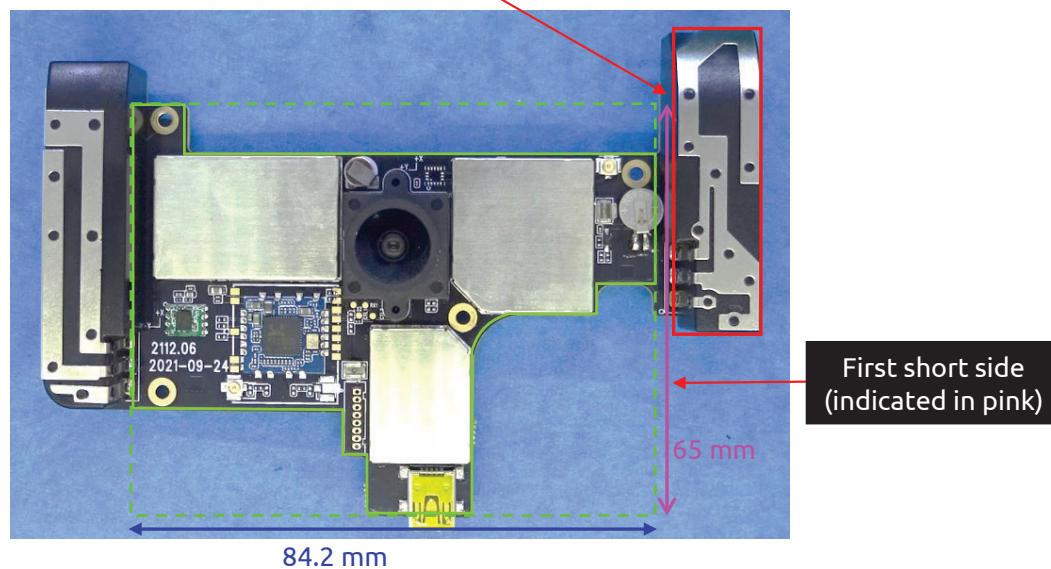

CONFIDENTIAL

# US 11,349,200 - VisionTrack VT3500-AI

## Claim 7

[7a] The wireless device of claim 6, wherein the first antenna contour comprises at least 20 segments.

[7a] The first antenna contour (indicated in blue and red) comprises at least 20 segments

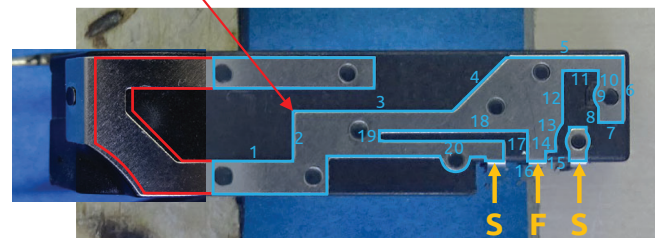

CONFIDENTIAL

# US 11,349,200 - VisionTrack VT3500-AI

## Claim 9

[9a] The wireless device of claim 6, wherein the second antenna defines a second antenna contour comprising an entire perimeter of the second antenna,

[9a] The second antenna defines a second antenna contour (indicated in blue and red) comprising an entire perimeter of the second antenna

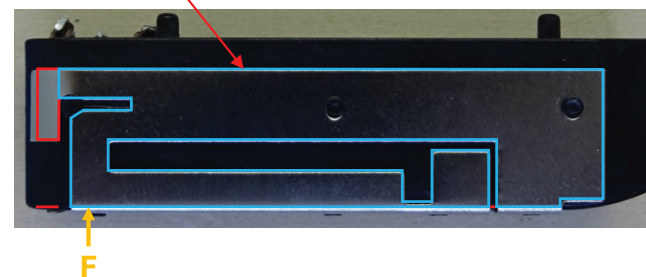
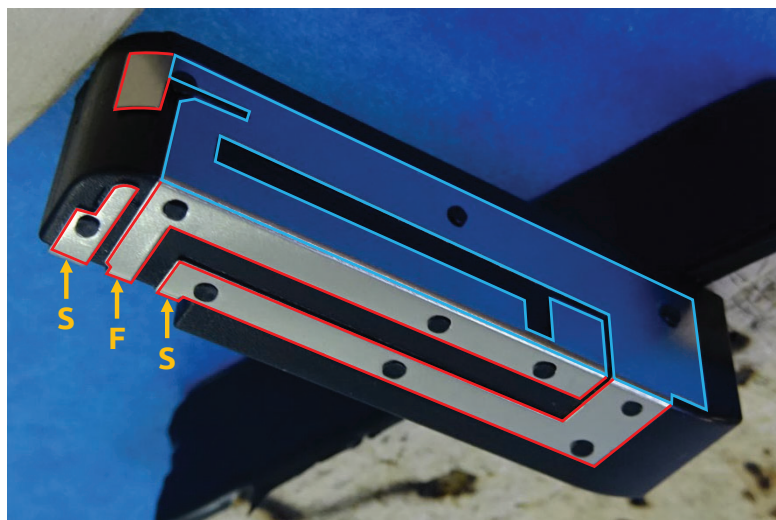

CONFIDENTIAL

# US 11,349,200 - VisionTrack VT3500-AI

## Claim 9

[9b] wherein a length of the second antenna contour is greater than four times a diagonal of the antenna rectangle.

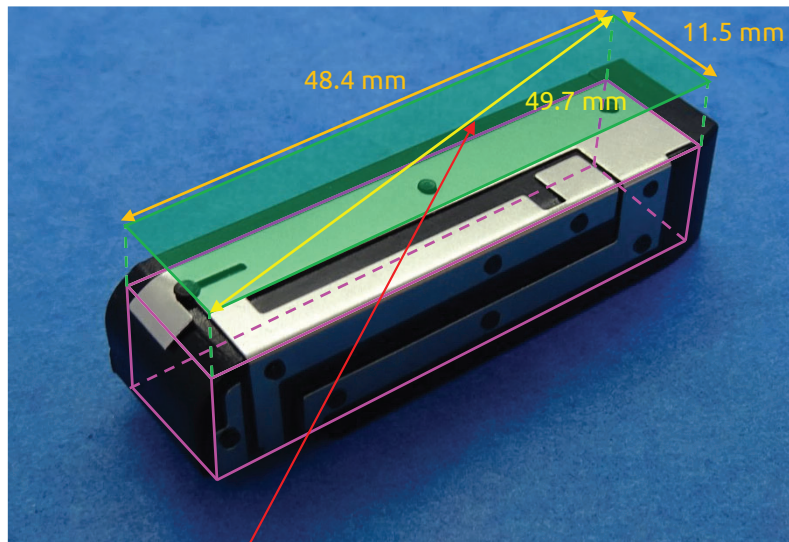

Diagonal of the antenna rectangle = 49.7 mm

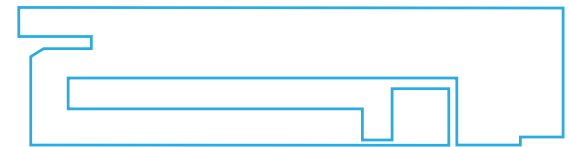
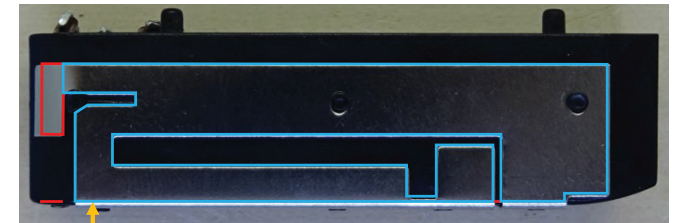

203.8 mm

15.4 mm

2.5 mm

0.4 mm

Length of the second antenna contour =  $(203.8 + 15.4 + 2.5 + 0.4) = 222.1$  mm

[9b] The length of the second antenna contour (222.1 mm) > 4\*Diagonal of the antenna rectangle (4\*49.7 = 198.8 mm)

CONFIDENTIAL

# US 11,349,200 - VisionTrack VT3500-AI

## Claim 10

[10a] The wireless device of claim 6, wherein the antenna system comprises a third antenna configured to provide operation in a wireless communication standard.

[10a] The antenna system comprises a third antenna (indicated in yellow) configured to provide operation in at least a wireless communication standard: WiFi

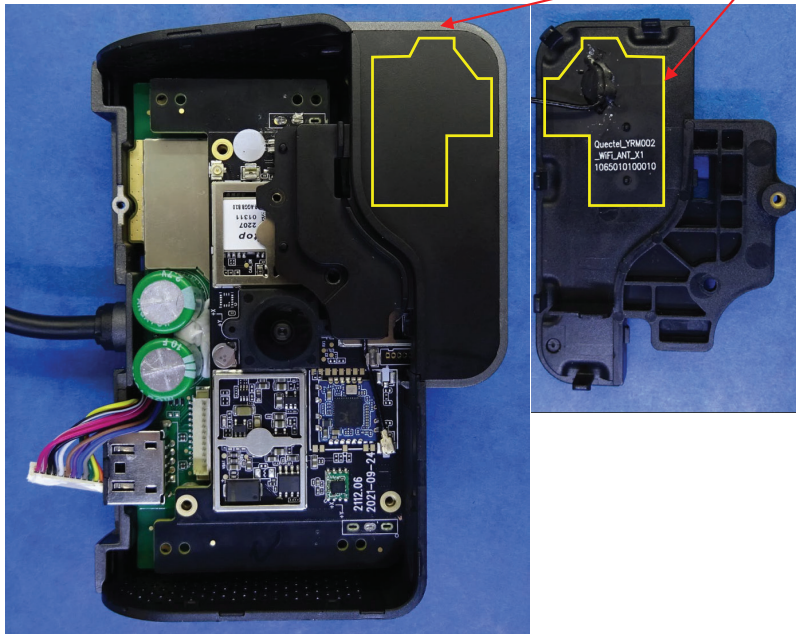

Mode
2.4G WiFi
5.8G WIFI

Source: RF Test Report

CONFIDENTIAL