

# 3GPP TS 36.101V1.0.0(2007-12)

---

*Technical Specification*

**3rd Generation Partnership Project;  
Technical Specification Group Radio Access Network;  
Evolved Universal Terrestrial Radio Access (E-UTRA);  
User Equipment (UE) radio transmission and reception;  
(Release 8)**

---



The present document has been developed within the 3<sup>rd</sup> Generation Partnership Project (3GPP™) and may be further elaborated for the purposes of 3GPP.

The present document has not been subject to any approval process by the 3GPP Organizational Partners and shall not be implemented. This Specification is provided for future development work within 3GPP only. The Organizational Partners accept no liability for any use of this Specification. Specifications and reports for implementation of the 3GPP™ system should be obtained via the 3GPP Organizational Partners Publications Offices.

Fractus Exhibit 2024

Geotab v. Fractus

Keywords

EUTRA, User Equipment (UE), radio, RF requirements

**3GPP**

Postal address

---

3GPP support office address

---

650 Route des Lucioles - Sophia Antipolis  
Valbonne - FRANCE  
Tel.: +33 4 92 94 42 00 Fax: +33 4 93 65 47 16

Internet

---

<http://www.3gpp.org>

---

**Copyright Notification**

---

No part may be reproduced except as authorized by written permission.  
The copyright and the foregoing restriction extend to reproduction in all media.

© 2006, 3GPP Organizational Partners (ARIB, ATIS, CCSA, ETSI, TTA, TTC).  
All rights reserved.

# Contents

Foreword.....	6
1 Scope.....	7
2 References.....	8
3 Definitions, symbols and abbreviations.....	9
3.1 Definitions.....	9
3.2 Symbols.....	9
3.3 Abbreviations.....	10
4 General.....	11
4.1 Relationship between Minimum Requirements and Test Requirements.....	11
5 Frequency bands and channel arrangement.....	12
5.1 General.....	12
5.2 Frequency bands.....	12
5.3 TX–RX frequency separation.....	12
5.4 Channel arrangement.....	12
5.4.1 Channel spacing.....	12
5.4.2 Channel bandwidth.....	<a href="#">1342</a>
5.4.2.1 Nominal channel bandwidth.....	<a href="#">1342</a>
5.4.2.2 Additional channel bandwidth.....	<a href="#">1442</a>
5.4.3 Channel raster.....	<a href="#">1542</a>
5.4.4 Channel number.....	<a href="#">1542</a>
5.4.5 EARFCN.....	<a href="#">1642</a>
6 Transmitter characteristics.....	<a href="#">1743</a>
6.1 General.....	<a href="#">1743</a>
6.2 Transmit power.....	<a href="#">1743</a>
6.2.1 Maximum Output Power (MOP).....	<a href="#">1743</a>
6.2.2 UE Power class.....	<a href="#">1743</a>
6.2.3 Maximum Power Reduction (MPR).....	<a href="#">1844</a>
6.2.4 Additional Maximum Power Reduction (A-MPR).....	<a href="#">1844</a>
6.3 Output power dynamics.....	<a href="#">1945</a>
6.3.1 Power control.....	<a href="#">1945</a>
6.3.2 Minimum output power.....	<a href="#">1945</a>
6.3.3 Transmit ON/OFF power.....	<a href="#">2046</a>
6.4 Control and monitoring functions.....	<a href="#">2046</a>
6.4.1 Out-of-synchronization handling of output power.....	<a href="#">2046</a>
6.5 Transmit signal quality.....	<a href="#">2046</a>
6.5.1 Frequency Error.....	<a href="#">2046</a>
6.5.2 Transmit modulation.....	<a href="#">2046</a>
6.5.2.1 Error Vector Magnitude.....	<a href="#">2046</a>
6.5.2.1.1 Minimum requirement.....	<a href="#">2046</a>
6.5.2.2 IQ-component.....	<a href="#">2147</a>
6.5.2.2.1 Minimum requirements.....	<a href="#">2147</a>
6.5.2.3 In-band emissions.....	<a href="#">2147</a>
6.5.2.3.1 Minimum requirements.....	<a href="#">2147</a>
6.6 Output RF spectrum emissions.....	<a href="#">2147</a>
6.6.1 Occupied bandwidth.....	<a href="#">2248</a>
6.6.2 Out of band emission.....	<a href="#">2248</a>
6.6.2.1 Spectrum emission mask.....	<a href="#">2248</a>
6.6.2.1.1 Minimum requirement.....	<a href="#">2248</a>
6.6.2.2 Additional Spectrum Emission Mask.....	<a href="#">2349</a>
6.6.2.2.1 Minimum requirement (network signalled value “NS_03”).....	<a href="#">2349</a>
6.6.2.2.2 Minimum requirement (network signalled value “NS_04”).....	<a href="#">2349</a>
6.6.2.2.3 Minimum requirement (network signalled).....	<a href="#">2420</a>
6.6.2.3 Adjacent Channel Leakage Ratio.....	<a href="#">2420</a>

6.6.2.3.1	Minimum requirement E-UTRA.....	2420
6.6.2.3.2	Minimum requirements UTRA.....	2524
6.6.2.4	Additional ACLR requirements.....	2524
6.6.2.4.1	Minimum requirements (network signalled value “NS_02”).....	2524
6.6.3	Spurious emissions.....	2622
6.6.3.1	Minimum requirements .....	2622
6.6.3.2	Spurious emission band UE co-existence.....	2622
6.6.3.3	Additional spurious emissions.....	2723
6.6.3.3.1	Minimum requirement (network signalled value “NS_05”).....	2723
6.6.3.3.2	Minimum requirements (network signalled).....	2723
6.7	Transmit intermodulation .....	2723
7	Receiver characteristics.....	2925
7.1	General.....	2925
7.2	Diversity characteristics.....	2925
7.3	Reference sensitivity power level .....	2925
7.3.1	Minimum requirements (QPSK).....	2925
7.3.2	Maximum Sensitivity Reduction (MSR).....	3026
7.4	Maximum input level.....	3026
7.4.1	Minimum requirements .....	3127
7.5	Adjacent Channel Selectivity (ACS) .....	3127
7.5.1	Minimum requirements .....	3127
7.6	Blocking characteristics.....	3228
7.6.1	In-band blocking .....	3228
7.6.1.1	Minimum requirements .....	3228
7.6.2	Out of-band blocking .....	3329
7.6.2.1	Minimum requirements .....	3329
7.6.3	Narrow band blocking.....	3430
7.6.3.1	Minimum requirements .....	3430
7.7	Spurious response .....	3534
7.7.1	Minimum requirements.....	3534
7.8	Intermodulation characteristics .....	3534
7.8.1	Wide band Intermodulation.....	3534
7.8.1.1	Minimum requirements .....	3534
7.8.2	Narrow band Intermodulation .....	3632
7.8.2.1	Minimum requirements .....	3632
7.9	Spurious emissions .....	3632
7.9.1	Minimum requirements.....	3632
8	Performance requirement .....	3733
8.1	General.....	3733
8.1.1	Dual-antenna receiver capability.....	3733
8.1.1.1	Simultaneous unicast and MBMS operations.....	3733
8.1.1.2	Dual-antenna receiver capability in idle mode .....	3733
<b>Annex A (normative): Measurement channels .....</b>		<b>3834</b>
A.1	General.....	3834
A.2	UL reference measurement channels .....	3834
A.3	DL reference measurement channels .....	3834
<b>Annex B (normative): Propagation conditions .....</b>		<b>3935</b>
B.1	General.....	3935
B.2	Propagation channels .....	3935
B.2.1	Static propagation condition .....	3935
B.2.2	Multi-path fading propagation conditions.....	3935
B.2.2.1	Delay profiles.....	3935
B.2.2.2	Doppler spectrum .....	4035
B.2.2.3	Multi-Antenna channel models .....	4235
B.2.2.4	Combinations of channel model parameters .....	4635
<b>Annex C (normative): Downlink Physical Channels.....</b>		<b>4736</b>
C.1	General.....	4736
C.2	Set-up.....	4736

C.3 Connection..... [4736](#)

**Annex D (normative): Characteristics of the interfering signal..... [4837](#)**

D.1 General..... [4837](#)

D.2 Interference signals..... [4837](#)

**Annex E (normative): Environmental conditions..... [4938](#)**

E.1 General..... [4938](#)

E.2 Environmental..... [4938](#)

E.2.1 Temperature..... [4938](#)

E.2.2 Voltage..... [4938](#)

E.2.3 Vibration..... [5039](#)

**Annex F (informative): Change history..... [5140](#)**

---

## Foreword

This Technical Specification (TS) has been produced by the 3<sup>rd</sup> Generation Partnership Project (3GPP).

The contents of the present document are subject to continuing work within the TSG and may change following formal TSG approval. Should the TSG modify the contents of the present document, it will be re-released by the TSG with an identifying change of release date and an increase in version number as follows:

Version x.y.z

Where:

- x the first digit:
  - 1 presented to TSG for information;
  - 2 presented to TSG for approval;
  - 3 or greater indicates TSG approved document under change control.
- y the second digit is incremented for all changes of substance, i.e. technical enhancements, corrections, updates, etc.
- z the third digit is incremented when editorial only changes have been incorporated in the document.

---

# 1 Scope

The present document establishes the User Equipment (UE) minimum RF characteristics of E-UTRA for both FDD and TDD modes

---

## 2 References

The following documents contain provisions which, through reference in this text, constitute provisions of the present document.

- References are either specific (identified by date of publication, edition number, version number, etc.) or non-specific.
- For a specific reference, subsequent revisions do not apply.
- For a non-specific reference, the latest version applies. In the case of a reference to a 3GPP document (including a GSM document), a non-specific reference implicitly refers to the latest version of that document *in the same Release as the present document*.

- [1] 3GPP TR 21.905
- [2] ETSI ETR 273: "Electromagnetic compatibility and Radio spectrum Matters (ERM); Improvement of radiated methods of measurement (using test sites) and evaluation of the corresponding measurement uncertainties; Part 1: Uncertainties in the measurement of mobile radio equipment characteristics; Subpart 2: Examples and annexes".
- [3] Recommendation ITU-R SM.329-10, "Unwanted emissions in the spurious domain"
- [4] Recommendation ITU-R M.1225, "Guidelines for Evaluation of Radio Transmission Technologies for IMT-2000", ITU-R, 1997.
- [5] 3GPP TR 25.943 V6.0.0 (2004-12), "Deployment aspects (Release 6)".
- [6] 3GPP TR 25.913: "Requirements for Evolved UTRA and UTRAN".
- [7] 3GPP TS 45.005 V7.8.0 (2006-11), "3rd Generation Partnership Project; Technical Specification Group GSM/EDGE Radio Access Network; Radio transmission and reception (Release 7)".
- [8] R4-070752, "Proposal for LTE channel models"
- [9] 3GPP TR 25.943 V6.0.0 (2004-12), "Deployment aspects (Release 6)".

## 3 Definitions, symbols and abbreviations

### 3.1 Definitions

For the purposes of the present document, the following terms and definitions apply.

<defined term> : <definition>.

For the purposes of the present document, the terms and definitions given in TR 21.905 [x] and the following apply. A term defined in the present document takes precedence over the definition of the same term, if any, in TR 21.905 [x].

**Channel edge:** The lowest and highest frequency of the carrier, separated by the channel bandwidth.

**Channel bandwidth:** The RF bandwidth supporting a single E-UTRA RF carrier with the transmission bandwidth configured in the uplink or downlink of a cell. The channel bandwidth is measured in MHz and is used as a reference for transmitter and receiver RF requirements.

**Maximum Output Power:** The mean power level per carrier of UE measured at the antenna connector in a specified reference condition.

**Mean power:** When applied to E-UTRA transmission this is the power measured in the operating system bandwidth of the carrier. The period of measurement shall be at least one subframe (1ms) for frame structure type 1 and one subframe (0.675ms) for frame structure type 2 excluding the guard interval, unless otherwise stated.

**Occupied bandwidth:** The width of a frequency band such that, below the lower and above the upper frequency limits, the mean powers emitted are each equal to a specified percentage  $\beta/2$  of the total mean power of a given emission.

**Output power:** The mean power of one carrier of the UE, delivered to a load with resistance equal to the nominal load impedance of the transmitter.

**Reference bandwidth:** The bandwidth in which an emission level is specified.

**Transmission bandwidth:** Bandwidth of an instantaneous transmission from a UE or BS, measured in Resource Block units.

**Transmission bandwidth configuration:** The highest transmission bandwidth allowed for uplink or downlink in a given channel bandwidth, measured in Resource Block units.

### 3.2 Symbols

For the purposes of the present document, the following symbols apply:

$BW_{\text{Channel}}$	Channel bandwidth
$F$	Frequency
$F_{\text{Interferer (offset)}}$	Frequency offset of the interferer
$F_{\text{Interferer}}$	Frequency of the interferer
$F_C$	Frequency of the carrier centre frequency
$F_{\text{DL\_low}}$	The lowest frequency of the downlink operating band
$F_{\text{DL\_high}}$	The highest frequency of the downlink operating band
$F_{\text{UL\_low}}$	The lowest frequency of the uplink operating band
$F_{\text{UL\_high}}$	The highest frequency of the uplink operating band
$N_{\text{DL}}$	Downlink EARFCN
$N_{\text{offs-DL}}$	Offset used for calculating downlink EARFCN
$N_{\text{offs-UL}}$	Offset used for calculating uplink EARFCN
$N_{\text{RB}}$	Transmission bandwidth configuration, expressed in units of resource blocks
$N_{\text{UL}}$	Uplink EARFCN
$R_{\text{av}}$	Minimum average throughput per RB
$P_{\text{Interferer}}$	Modulated mean power of the interferer
$\Delta F_{\text{OOB}}$	$\Delta$ Frequency of Out Of Band emission

### 3.3 Abbreviations

For the purposes of the present document, the abbreviations given in TR 21.905 [1] and the following apply. An abbreviation defined in the present document takes precedence over the definition of the same abbreviation, if any, in TR 21.905 [1].

ACLR	Adjacent Channel Leakage Ratio
ACS	Adjacent Channel Selectivity
A-MPR	Additional Maximum Power Reduction
AWGN	Additive White Gaussian Noise
BS	Base Station
CW	Continuous Wave
DL	Downlink
EARFCN	E-UTRA Absolute Radio Frequency Channel Number
E-UTRA	Evolved UMTS Terrestrial Radio Access
EUTRAN	Evolved UMTS Terrestrial Radio Access Network
EVM	Error Vector Magnitude
FDD	Frequency Division Duplex
FRC	Fixed Reference Channel
HD-FDD	Half- Duplex FDD
MCS	Modulation and Coding Scheme
MOP	Maximum Output Power
MPR	Maximum Power Reduction
MSR	Maximum Sensitivity Reduction
OOB	Out-of-band
PA	Power Amplifier
REFSENS	Reference Sensitivity power level
SNR	Signal-to-Noise Ratio
TDD	Time Division Duplex
UE	User Equipment
UL	Uplink
UMTS	Universal Mobile Telecommunications System
UTRA	UMTS Terrestrial Radio Access
UTRAN	UMTS Terrestrial Radio Access Network

Other abbreviations used in the present document are listed in 3GPP TR 21.905 [1].

---

## 4 General

### 4.1 Relationship between Minimum Requirements and Test Requirements

The Minimum Requirements given in this specification make no allowance for measurement uncertainty. The test specification TS 36.xxx section y defines Test Tolerances. These Test Tolerances are individually calculated for each test. The Test Tolerances are used to relax the Minimum Requirements in this specification to create Test Requirements.

The measurement results returned by the Test System are compared - without any modification - against the Test Requirements as defined by the shared risk principle.

The Shared Risk principle is defined in ITU-R M.1545 [3].

## 5 Frequency bands and channel arrangement

### 5.1 General

The channel arrangements presented in this clause are based on the frequency bands and channel bandwidths defined in the present release of specifications.

NOTE: Other frequency bands and channel bandwidths may be considered in future releases.

### 5.2 Frequency bands

E-UTRA is designed to operate in the frequency bands defined in Table 5.2-1.

Table 5.2-1 E-UTRA frequency bands

E-UTRA Band	Uplink (UL) eNode B receive UE transmit	Downlink (DL) eNode B transmit UE receive	UL-DL Band separation	Duplex Mode
	F <sub>UL_low</sub> – F <sub>UL_high</sub>	F <sub>DL_low</sub> – F <sub>DL_high</sub>	F <sub>DL_low</sub> - F <sub>UL_high</sub>	
1	1920 MHz – 1980 MHz	2110 MHz – 2170 MHz	130 MHz	FDD
2	1850 MHz – 1910 MHz	1930 MHz – 1990 MHz	20 MHz	FDD
3	1710 MHz – 1785 MHz	1805 MHz – 1880 MHz	20 MHz	FDD
4	1710 MHz – 1755 MHz	2110 MHz – 2155 MHz	355 MHz	FDD
5	824 MHz – 849 MHz	869 MHz – 894 MHz	20 MHz	FDD
6	830 MHz – 840 MHz	875 MHz – 885 MHz	35 MHz	FDD
7	2500 MHz – 2570 MHz	2620 MHz – 2690 MHz	50 MHz	FDD
8	880 MHz – 915 MHz	925 MHz – 960 MHz	10 MHz	FDD
9	1749.9 MHz – 1784.9 MHz	1844.9 MHz – 1879.9 MHz	60 MHz	FDD
10	1710 MHz – 1770 MHz	2110 MHz – 2170 MHz	340 MHz	FDD
11	1427.9 MHz – 1452.9 MHz	1475.9 MHz – 1500.9 MHz	23 MHz	FDD
12	[TBD] – [TBD]	[TBD] – [TBD]	[TBD]	FDD
13	[TBD] – [TBD]	[TBD] – [TBD]	[TBD]	FDD
14	[TBD] – [TBD]	[TBD] – [TBD]	[TBD]	FDD
...				
33	1900 MHz – 1920 MHz	1900 MHz – 1920 MHz	N/A	TDD
34	2010 MHz – 2025 MHz	2010 MHz – 2025 MHz	N/A	TDD
35	1850 MHz – 1910 MHz	1850 MHz – 1910 MHz	N/A	TDD
36	1930 MHz – 1990 MHz	1930 MHz – 1990 MHz	N/A	TDD
37	1910 MHz – 1930 MHz	1910 MHz – 1930 MHz	N/A	TDD
38	2570 MHz – 2620 MHz	2570 MHz – 2620 MHz	N/A	TDD

### 5.3 TX–RX frequency separation

### 5.4 Channel arrangement

#### 5.4.1 Channel spacing

The spacing between carriers will depend on the deployment scenario, the size of the frequency block available and the channel bandwidths. The nominal channel spacing between two adjacent E-UTRA carriers is defined as following:

$$\text{Nominal Channel spacing} = (\text{BW}_{\text{Channel}(1)} + \text{BW}_{\text{Channel}(2)})/2$$

where  $\text{BW}_{\text{Channel}(1)}$  and  $\text{BW}_{\text{Channel}(2)}$  are the channel bandwidths of the two respective E-UTRA carriers. The channel spacing can be adjusted to optimize performance in a particular deployment scenario

### 5.4.2 Channel bandwidth

Requirements in present document are specified for the channel bandwidths listed in Table 5.4-1.

**Table 5.4-1 Transmission bandwidth configuration  $N_{RB}$  in E-UTRA channel bandwidths**

Channel bandwidth $BW_{Channel}$ [MHz]	1.4	1.6	3	3.2	5	10	15	20
FDD mode	6	n/a	15	n/a	25	50	75	100
TDD mode [Frame Structure Type 1]	[6]	[TBD]	[15]	[TBD]	25	50	75	100
TDD mode [Frame Structure Type 2]	[TBD]	[7]	[TBD]	[16]	25	50	75	100

Figure 5.4-1 shows the relation between the Channel bandwidth ( $BW_{Channel}$ ) and the Transmission bandwidth configuration ( $N_{RB}$ ). The channel edges are defined as the lowest and highest frequencies of the carrier separated by the channel bandwidth, i.e. at  $F_c \pm BW_{Channel} / 2$ .

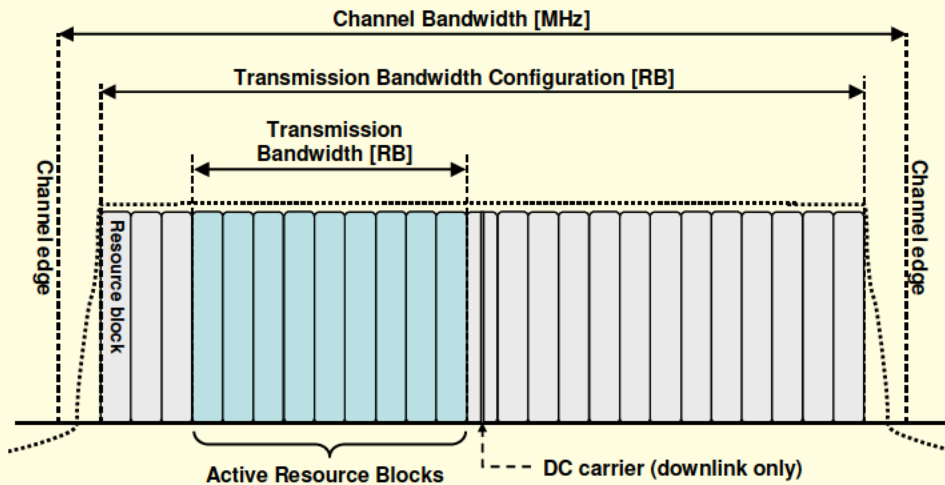

**Figure 5.4-1 Definition of Channel Bandwidth and Transmission Bandwidth Configuration.**

#### 5.4.2.1 Nominal channel bandwidth

Table 5.4.2-1 specifies the nominal channel bandwidth which are supported for the E-UTRA band

Table 5.4.2-1: E-UTRA channel bandwidth

E-UTRA band / channel bandwidth								
E-UTRA Band	1.4 MHz	1.6 MHz	3 MHz	3.2 MHz	5 MHz	10 MHz	15 MHz	20 MHz
1					√	√	√	√
2	√		√		√	√		
3	√		√		√	√		
4	√		√		√	√	√	√
5	√		√		√	[N]		
6					√	[N]		
7					√	√	[N]	
8	√		√		√	[N]		
9					√	√	[N]	[N]
10					√	√	√	√
11					√			
12								
13								
14								
...								
33					FFS	FFS		
34					FFS	FFS		
35	FFS	FFS	FFS	FFS	FFS	FFS	FFS	FFS
36	FFS	FFS	FFS	FFS	FFS	FFS	FFS	FFS
37	FFS	FFS	FFS	FFS	FFS	FFS	FFS	FFS
38					FFS	FFS		

#### 5.4.2.2 Additional channel bandwidth

The following additional channel bandwidth can be supported if certain relaxations of the UE performance are allowed or UE functionality is limited. These relaxations and limitations are TBD.

Table 5.4.4.2-1: Additional E-UTRA channel bandwidth

E-UTRA band / channel bandwidth								
E-UTRA Band	1.4 MHz	1.6 MHz	3 MHz	3.2 MHz	5 MHz	10 MHz	15 MHz	20 MHz
1								
2							√	√
3							√	√
4								
5						[√]	√	√
6						[√]		
7							[√]	√
8						[√]		
9							[√]	[√]
10								
11						√	√	√
12								
13								
14								
...								
33								
34								
35								
36								
37								
38								

### 5.4.3 Channel raster

The channel raster is 100 kHz for all bands, which means that the carrier centre frequency must be an integer multiple of 100 kHz.

### 5.4.4 Channel number

The carrier frequency in the uplink and downlink is designated by the E-UTRA Absolute Radio Frequency Channel Number (EARFCN). The carrier frequency in MHz for the downlink is given by the following equation, where  $F_{DL\_low}$  and  $N_{Offs-DL}$  are given in table 5.4.4-1 and  $N_{DL}$  is the downlink EARFCN.

$$F_{DL} = F_{DL\_low} + 0.1(N_{DL} - N_{Offs-DL})$$

The carrier frequency in MHz for the uplink is given by the following equation where  $F_{UL\_low}$  and  $N_{Offs-UL}$  are given in table 5.4.4-1 and  $N_{UL}$  is the uplink EARFCN.

$$F_{UL} = F_{UL\_low} + 0.1(N_{UL} - N_{Offs-UL})$$

Table 5.4.4-1 E-UTRA channel numbers

Band	Downlink			Uplink		
	F <sub>DL_low</sub>	N <sub>Offs-DL</sub>	Range of N <sub>DL</sub>	F <sub>UL_low</sub>	N <sub>Offs-UL</sub>	Range of N <sub>UL</sub>
1	2110	0	0 – 599	1920	13000	13000 – 13599
2	1930	600	600 – 1199	1850	13600	13600 – 14199
3	1805	1200	1200 – 1949	1710	14200	14200 – 14949
4	2110	1950	1950 – 2399	1710	14950	14950 – 15399
5	869	2400	2400 – 2649	824	15400	15400 – 15649
6	875	2650	2650 – 2749	830	15650	15650 – 15749
7	2620	2750	2750 – 3449	2500	15750	15750 – 16449
8	925	3450	3450 – 3799	880	16450	16450 – 16799
9	1844.9	3800	3800 – 4149	1749.9	16800	16800 – 17149
10	2110	4150	4150 – 4749	1710	17150	17150 – 17749
11	1475.9	4750	4750 – 4999	1427.9	17750	17750 – 17999
...						
33	1900	26000	26000 – 26184	1900	26000	26000 – 26184
34	2010	26185	26185 – 26319	2010	26185	26185 – 26319
35	1850	26320	26320 – 26904	1850	26320	26320 – 26904
36	1930	26905	26905 – 27489	1930	26905	26905 – 27489
37	1910	27490	27490 – 27674	1910	27490	27490 – 27674
38	2570	27675	27675 – 28159	2570	27675	27675 – 28159

## 5.4.5 EARFCN

## 6 Transmitter characteristics

### 6.1 General

Unless otherwise stated, the transmitter characteristics are specified at the antenna connector of the UE with a single transmit antenna. For UE with integral antenna only, a reference antenna with a gain of 0 dBi is assumed.

### 6.2 Transmit power

#### 6.2.1 Maximum Output Power (MOP)

The Maximum Output Power (MOP) defined in Table 6.2.1-1 is the broadband transmit power of the UE, i.e. the power in the channel bandwidth (clause 5.2) for all transmit bandwidth configurations (resource blocks).

**Table 6.2.1-1: Maximum Output Power (MOP)**

Class	Power (dBm)
1	
2	[+27]
3	[+25]
4	

#### 6.2.2 UE Power class

The following UE Power Classes define the nominal maximum output power. The nominal power is defined as the broadband transmit power of the UE, i.e. the power in the channel bandwidth (clause 5.2) of the radio access mode. The period of measurement shall be at least one [timeslot/ frame/TTI].

**Table 6.2.2-1: UE Power Class**

E-UTRA Band	Class 1 (dBm)	Tolerance (dB)	Class 2 (dBm)	Tolerance (dB)	Class 3 (dBm)	Tolerance (dB)	Class 4 (dBm)	Tolerance (dB)
1					[23]	[±2]		
2					[23]	[±2]		
3					[23]	[±2]		
4					[23]	[±2]		
5					[23]	[±2]		
6					[23]	[±2]		
7					[23]	[±2]		
8					[23]	[±2]		
9					[23]	[±2]		
10					[23]	[±2]		
11					[23]	[±2]		
12					[23]	[±2]		
13					[23]	[±2]		
14					[23]	[±2]		
...								
33					[23]	[±2]		
34					[23]	[±2]		
35					[23]	[±2]		
36					[23]	[±2]		
37					[23]	[±2]		
38					[23]	[±2]		

The transmission bandwidth configuration (resource blocks) for the maximum output power specified in Table 6.2.2-1 is defined in Table 6.2.2-2 below for QPSK modulation.

**Table 6.2.2-2: UE Power Class / channel bandwidth / transmission configuration**

UE Power Class	Channel bandwidth / Transmission bandwidth configuration [RB]							
	1.4 MHz	1.6 MHz	3.0 MHz	3.2 MHz	5 MHz	10 MHz	15 MHz	20 MHz
1								
2								
3	≤ TBD	≤ TBD	≤ TBD	≤ TBD	≤ 8	≤ 12	≤ 16	≤ 18
4								

### 6.2.3 Maximum Power Reduction (MPR)

For UE Power Class 3, the allowed Maximum Power Reduction (MPR) for the nominal maximum output power in 6.2.2 due to higher order modulation and transmit bandwidth configuration (resource blocks) is specified in Table 6.2.3-1.

**Table 6.2.3-1: Maximum Power Reduction (MPR) for PC 3**

Modulation	Channel bandwidth / Transmission bandwidth configuration [RB]								MPR (dB)
	1.4 MHz	1.6 MHz	3.0 MHz	3.2 MHz	5 MHz	10 MHz	15 MHz	20 MHz	
QPSK	TBD		TBD		> 8	> 12	> 16	> 18	≤ 1
16 QAM	TBD		TBD		≤ [8]	≤ [12]	≤ [16]	≤ [18]	≤ 1
16 QAM	TBD		TBD		> [8]	> [12]	> [16]	> [18]	≤ 2

### 6.2.4 Additional Maximum Power Reduction (A-MPR)

Additional ACLR and spectrum emission requirements can be signalled by the network to indicate that the UE shall meet also additional requirements in a specific deployment scenario. To meet these additional requirements the concept of A-MPR is introduced.

For UE Power Class 3 the specific requirements and identified sub-clauses are specified in table 6.2.4-1 along with the allowed A-MPR values that may be used to meet these requirements. The allowed A-MPR values specified below are in addition to the allowed MPR requirements specified in clause 6.2.3.

Table 6.2.4-1: Additional Maximum Power Reduction (A-MPR) / Spectrum Emission requirements

Network Signalling value	Requirements (sub-clause)	E-UTRA Band	Channel bandwidth (MHz)	Resources Blocks	A-MPR (dB)	Comment
NS_01	-	-	-			Reserved
NS_02	6.6.2.3.1	1, 6, 9,10,11	10	> [30]	≤ 2	UTRA <sub>ACL2bis</sub>
NS_03	6.6.2.2.1	2, 4,10	3	>[5]		FCC Part 22 OOB
	6.6.2.2.1	2, 4,10	5	>[5]		FCC Part 22 OOB
	6.6.2.2.1	2, 4,10	10	>[7]		FCC Part 22 OOB
	6.6.2.2.1	2, 4,10	15	TBD		FCC Part 22 OOB
	6.6.2.2.1	2, 4,10	20	TBD		FCC Part 22 OOB
NS_04	6.6.2.2.2	TBD	TBD	TBD		FCC Part 27 OOB
NS_05	6.6.3.3.1	1 <sup>2</sup>	10,15,20	> [50] for QPSK	≤ 1	PHS protection
NS_06	-	-	-			Reserved
..						
NS_32	-	-	-	-	-	

Note:  $0 \leq A\text{-MPR} \leq 3$

Note2: Applicable when the edge of the assigned E-UTRA UL channel bandwidth frequency is larger than or equal to 1920MHz + the Channel BW assigned. Operations below this point are for further study.

## 6.3 Output power dynamics

### 6.3.1 Power control

### 6.3.2 Minimum output power

The minimum controlled output power of the UE is defined as the broadband transmit power of the UE, i.e. the power in the channel bandwidth (clause 5.2) for all transmit bandwidth configurations (resource blocks), when the power is set to a minimum value.

#### 6.3.2.1 Minimum requirement

The minimum output power is defined as the mean power in one sub-frame (1ms). The minimum output power shall be less than [-30] dBm.

### 6.3.3 Transmit ON/OFF power

## 6.4 Control and monitoring functions

### 6.4.1 Out-of-synchronization handling of output power

## 6.5 Transmit signal quality

### 6.5.1 Frequency Error

The UE modulated carrier frequency shall be accurate to within  $\pm 0.1$  PPM observed over a period of one sub-frame (1ms) for generic frame structure type 1 and one sub-frame (0.675ms) for frame structure type 2 excluding the guard period (Cyclic prefix).

### 6.5.2 Transmit modulation

Transmit modulation defines the modulation quality for expected in-channel RF transmissions from the UE. This transmit modulation limit is specified in terms of; an Error Vector Magnitude (EVM) for the allocated resources blocks (RB), an I/Q component and an in-band emissions for the non-allocated RB.

#### 6.5.2.1 Error Vector Magnitude

The Error Vector Magnitude is a measure of the difference between the reference waveform and the measured waveform. This difference is called the error vector. Before calculating the EVM the measured waveform is corrected by the sample timing offset and RF frequency offset. Then the IQ origin offset is removed from the measured waveform.

The measured waveform is further modified by selecting the absolute phase and absolute amplitude of the Tx chain. The EVM result is defined after the front-end IDFT as the square root of the ratio of the mean error vector power to the mean reference power expressed as a %. The measurement interval is one [timeslot] except when the mean power between slots is expected to change whereupon the measurement interval is reduced by []  $\mu$ s at each end of the slot.

The IQ origin offset shall be removed from the evaluated signal before calculating the EVM; however, the removed relative IQ origin offset power (relative carrier leakage power) also has to satisfy the applicable requirement.

##### 6.5.2.1.1 Minimum requirement

The RMS average of the basic EVM measurements for [10 consecutive sub-frames] for the different modulations schemes shall not exceed the values specified in Table 6.5.2.1.1-1 for the parameters defined in Table 6.5.2.1.1-2.

**Table 6.5.2.1.1-1: Minimum requirements for Error Vector Magnitude**

Parameter	Unit	Level
QPSK	%	17.5
16QAM	%	12.5
64QAM	%	[tbd]

**Table 6.5.2.1.1-2: Parameters for Error Vector Magnitude**

Parameter	Unit	Level
UE Output Power	dBm	$\geq -30$
Operating conditions		Normal conditions
Power control step size	dB	[tbd]
Basic measurement period (Note 1,2)	[slot]	[ ] ms
Note 1: Less any [ ] $\mu$ s transient periods		
Note 2: [ ] ms for generic frame structure FS1 and [ ] ms for FS2		

## 6.5.2.2 IQ-component

The IQ origin offset is the phase and amplitude of an additive sinusoid waveform that has the same frequency as the reference waveform carrier frequency.

### 6.5.2.2.1 Minimum requirements

The relative carrier leakage power (IQ origin offset power) shall not exceed the values specified in Table 6.5.2.2.1-1.

**Table 6.5.2.2.1-1: Minimum requirements for Relative Carrier Leakage Power**

LO Leakage	Parameters	Relative Limit (dBc)
	For output power $>0$ dBm	-25
	For output power $\leq 0$ dBm	-20

## 6.5.2.3 In-band emissions

### 6.5.2.3.1 Minimum requirements

## 6.6 Output RF spectrum emissions

The output UE transmitter spectrum consists of the three components; the emission within the occupied bandwidth (channel bandwidth), the Out Of Band (OOB) emissions and the far out spurious emission domain.

Figure 6.6-1: Transmitter RF spectrum

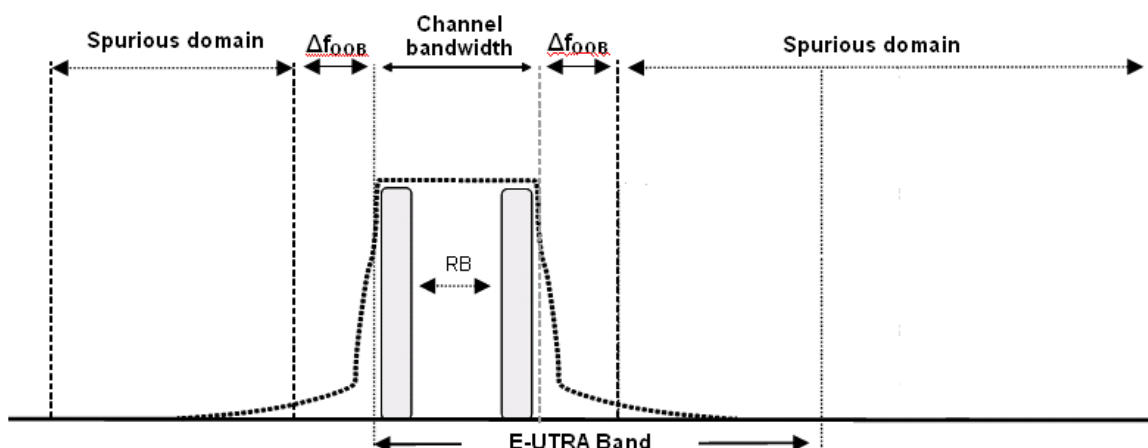

### 6.6.1 Occupied bandwidth

Occupied bandwidth is defined as the bandwidth containing 99 % of the total integrated mean power of the transmitted spectrum on the assigned channel. The occupied bandwidth for all transmission bandwidth configurations (Resources Blocks) shall be less than the channel bandwidth specified in Table 6.6.1-1

Table 6.6.1-1: Occupied channel bandwidth

	Occupied channel bandwidth / channel bandwidth							
	1.4 MHz	1.6 MHz	3.0 MHz	3.2 MHz	5 MHz	10 MHz	15 MHz	20 MHz
Channel bandwidth [MHz]	1.4	1.6	3	3.2	5	10	15	20

### 6.6.2 Out of band emission

The Out of band emissions are unwanted emissions immediately outside the assigned channel bandwidth resulting from the modulation process and non-linearity in the transmitter but excluding spurious emissions. This out of band emission limit is specified in terms of a spectrum emission mask and an Adjacent Channel Leakage power Ratio.

#### 6.6.2.1 Spectrum emission mask

The spectrum emission mask of the UE applies to frequencies ( $\Delta f_{OOB}$ ) starting from the  $\pm$  edge of the assigned E-UTRA channel bandwidth. For frequencies greater than ( $\Delta f_{OOB}$ ) as specified in Table 6.6.2.1.1-1 the spurious requirements in clause 6.6.3 are applicable.

##### 6.6.2.1.1 Minimum requirement

The power of any UE emission shall not exceed the levels specified in Table 6.6.2.1.1-1 for the specified channel bandwidth.

**Table 6.6.2.1.1-1: General E-UTRA spectrum emission mask**

$\Delta f_{\text{OBS}}$ (MHz)	Spectrum emission limit (dBm)/ Channel bandwidth								Measurement bandwidth
	1.4 MHz	1.6 MHz	3.0 MHz	3.2 MHz	5 MHz	10 MHz	15 MHz	20 MHz	
$\pm 0-1$	[TBD]	[TBD]	[TBD]	[TBD]	-15	-18	-20	-21	30 kHz
$\pm 1-2.5$	[-10]	[-10]	[-10]	[TBD]	-10	-10	-10	-10	1 MHz
$\pm 2.5-5$	[-25]	[-25]	[-10]	[-10]	-10	-10	-10	-10	1 MHz
$\pm 5-6$			[-25]	[-25]	-13	-13	-13	-13	1 MHz
$\pm 6-10$					-25	-13	-13	-13	1 MHz
$\pm 10-15$						-25	-13	-13	1 MHz
$\pm 15-20$							-25	-13	1 MHz
$\pm 20-25$								-25	1 MHz

Note: As a general rule, the resolution bandwidth of the measuring equipment should be equal to the measurement bandwidth. However, to improve measurement accuracy, sensitivity and efficiency, the resolution bandwidth may be smaller than the measurement bandwidth. When the resolution bandwidth is smaller than the measurement bandwidth, the result should be integrated over the measurement bandwidth in order to obtain the equivalent noise bandwidth of the measurement bandwidth.

### 6.6.2.2 Additional Spectrum Emission Mask

This requirement is specified in terms of an “additional spectrum emission” requirement.

#### 6.6.2.2.1 Minimum requirement (network signalled value “NS\_03”)

Additional spectrum emission requirements are signalled by the network to indicate that the UE shall meet an additional requirement for a specific deployment scenario as part of the cell handover/broadcast message.

When “NS\_03” is indicated in the cell, the power of any UE emission shall not exceed the levels specified in Table 6.6.2.2-1.

**Table 6.6.2.2.1-1: Additional requirements (FCC Part 22)**

$\Delta f_{\text{OBS}}$ (MHz)	Spectrum emission limit (dBm)/ Channel bandwidth								Measurement bandwidth
	1.4 MHz	1.6 MHz	3.0 MHz	3.2 MHz	5 MHz	10 MHz	15 MHz	20 MHz	
$\pm 0-1$	[TBD]	[TBD]	[TBD]	[TBD]	-15	-20	-25	-30	30 kHz
$\pm 1-2.5$	[TBD]	[TBD]	[TBD]	[TBD]	-13	-13	-13	-13	1 MHz
$\pm 2.5-5$	[TBD]	[TBD]	[TBD]	[TBD]	-13	-13	-13	-13	1 MHz
$\pm 5-6$	[TBD]	[TBD]	[TBD]	[TBD]	-13	-13	-13	-13	1 MHz
$\pm 6-10$	[TBD]	[TBD]	[TBD]	[TBD]	-13	-13	-13	-13	1 MHz
$\pm 10-15$	[TBD]	[TBD]	[TBD]	[TBD]	-13	-13	-13	-13	1 MHz
$\pm 15-20$	[TBD]	[TBD]	[TBD]	[TBD]	-13	-13	-13	-13	1 MHz
$\pm 10-25$	[TBD]	[TBD]	[TBD]	[TBD]	-13	-13	-13	-13	1 MHz

Note: As a general rule, the resolution bandwidth of the measuring equipment should be equal to the measurement bandwidth. However, to improve measurement accuracy, sensitivity and efficiency, the resolution bandwidth may be smaller than the measurement bandwidth. When the resolution bandwidth is smaller than the measurement bandwidth, the result should be integrated over the measurement bandwidth in order to obtain the equivalent noise bandwidth of the measurement bandwidth.

#### 6.6.2.2.2 Minimum requirement (network signalled value “NS\_04”)

Additional spectrum emission requirements are signalled by the network to indicate that the UE shall meet an additional requirement for a specific deployment scenario as part of the cell handover/broadcast message.

When “NS\_04” is indicated in the cell, the power of any UE emission shall not exceed the levels specified in Table 6.6.2.2-1.

**Table 6.6.2.2-1: Additional requirements (FCC Part 27)**

$\Delta f_{00B}$ (MHz)	Spectrum emission limit (dBm)/ Channel bandwidth								Measurement bandwidth
	1.4 MHz	1.6 MHz	3.0 MHz	3.2 MHz	5 MHz	10 MHz	15 MHz	20 MHz	
$\pm 0-1$	[TBD]	[TBD]	[TBD]	[TBD]	-15	-20	-25	-30	30 kHz
$\pm 1-2.5$	[TBD]	[TBD]	[TBD]	[TBD]	-15	-15	-15	-15	1 MHz
$\pm 2.5-5.5$	[TBD]	[TBD]	[TBD]	[TBD]	-15	-15	-15	-15	1 MHz
$\pm 5.5-6$	[TBD]	[TBD]	[TBD]	[TBD]	-25	-25	-25	-25	1 MHz
$\pm 6-10$	[TBD]	[TBD]	[TBD]	[TBD]	-25	-25	-25	-25	1 MHz
$\pm 10-15$	[TBD]	[TBD]	[TBD]	[TBD]	-25	-25	-25	-25	1 MHz
$\pm 15-20$	[TBD]	[TBD]	[TBD]	[TBD]	-25	-25	-25	-25	1 MHz
$\pm 10-25$	[TBD]	[TBD]	[TBD]	[TBD]	-25	-25	-25	-25	1 MHz

Note: As a general rule, the resolution bandwidth of the measuring equipment should be equal to the measurement bandwidth. However, to improve measurement accuracy, sensitivity and efficiency, the resolution bandwidth may be smaller than the measurement bandwidth. When the resolution bandwidth is smaller than the measurement bandwidth, the result should be integrated over the measurement bandwidth in order to obtain the equivalent noise bandwidth of the measurement bandwidth.

6.6.2.2.3 Minimum requirement (network signalled)

6.6.2.3 Adjacent Channel Leakage Ratio

Adjacent Channel Leakage power Ratio (ACLR) is the ratio of the filtered mean power centred on the assigned channel frequency to the filtered mean power centred on an adjacent channel frequency. ACLR requirements are specified for two scenarios for an adjacent E-UTRA and /or UTRA channel as shown in Figure 6.6.2.3 -1.

**Figure 6.6.2.3-1: Adjacent Channel Leakage requirements**

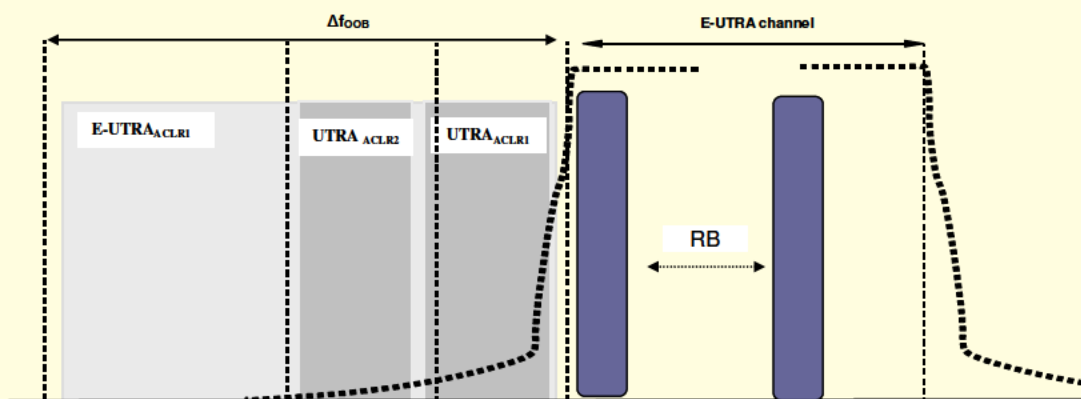

6.6.2.3.1 Minimum requirement E-UTRA

E-UTRA Adjacent Channel Leakage power Ratio (E-UTRA<sub>ACLR</sub>) is the ratio of the filtered mean power centred on the assigned channel frequency to the filtered mean power centred on an adjacent channel frequency. The E-UTRA on channel and adjacent channel power is measured with a [rectangular measurement bandwidth filter.]

**Table 6.6.2.3.1-1: General requirements for E-UTRA<sub>ACLR</sub>**

	Channel bandwidth / E-UTRA <sub>ACLR1</sub> / measurement bandwidth							
	1.4 MHz	1.6 MHz	3.0 MHz	3.2 MHz	5 MHz	10 MHz	15 MHz	20 MHz
E-UTRA <sub>ACLR1</sub>	30 dB	30 dB	30 dB	30 dB	30 dB	30 dB	30 dB	30 dB
E-UTRA channel Measurement bandwidth					[4.5] MHz	[9.0] MHz	[13.5] MHz	[18] MHz

### 6.6.2.3.2 Minimum requirements UTRA

UTRA Adjacent Channel Leakage power Ratio (UTRA<sub>ACLR</sub>) is the ratio of the filtered mean power centred on the assigned E-UTRA channel frequency to the filtered mean power centred on an adjacent(s) UTRA channel frequency.

UTRA Adjacent Channel Leakage power Ratio is specified for both the first UTRA 5 MHz adjacent channel (UTRA<sub>ACLR1</sub>) and the 2<sup>nd</sup> UTRA 5MHz adjacent channel (UTRA<sub>ACLR2</sub>). The UTRA channel is measured with a 3.84 MHz RRC bandwidth filter with roll-off factor  $\alpha = 0.22$ . The E-UTRA channel is measured with a [rectangular measurement bandwidth filter]

**Table 6.6.2.3.2-1: Additional requirements**

	Channel bandwidth / UTRA <sub>ACLR1/2</sub> / measurement bandwidth							
	1.4 MHz	1.6 MHz	3.0 MHz	3.2 MHz	5 MHz	10 MHz	15 MHz	20 MHz
UTRA <sub>ACLR1</sub>	33 dB	33 dB	33 dB	33 dB	33 dB	33 dB	33 dB	33 dB
UTRA <sub>ACLR2</sub>	-	-	-	-	36 dB	36 dB	36 dB	36 dB
E-UTRA channel Measurement bandwidth		-	-	-	[4.5] MHz	[9.0] MHz	[13.5] MHz	[18] MHz
UTRA channel Measurement bandwidth	-	-	-	-	3.84 MHz	3.84 MHz	3.84 MHz	3.84 MHz

### 6.6.2.4 Additional ACLR requirements

This requirement is specified in terms of an additional UTRA<sub>ACLR2</sub> requirement.

#### 6.6.2.4.1 Minimum requirements (network signalled value "NS\_02")

"NS\_02" is signalled by the network to indicate that the UE shall meet this additional requirement for a specific deployment scenario as part of the cell handover/broadcast message.

The Additional ACLR requirements is specified for the 2<sup>nd</sup> UTRA 5MHz adjacent channel (UTRA<sub>ACLR2</sub>). The UTRA channel is measured with a 3.84 MHz RRC bandwidth filter with roll-off factor  $\alpha = 0.22$ . The E-UTRA channel is measured with a [rectangular measurement bandwidth filter.]

**Table 6.6.2.3.2-1: Additional requirements (UTRA<sub>ACL2</sub>)**

	Channel bandwidth / UTRA <sub>ACL2</sub> / measurement bandwidth							
	1.4 MHz	1.6 MHz	3.0 MHz	3.2 MHz	5 MHz	10 MHz	15 MHz	20 MHz
UTRA <sub>ACL2bis</sub>	-	-	-	-	43 dB	43 dB	-	-
E-UTRA channel Measurement bandwidth	-	-	-	-	[4.5] MHz	[9.0] MHz	-	-
UTRA channel Measurement bandwidth	-	-	-	-	3.84 MHz	3.84 MHz	-	-

For E-UTRA TDD mode, operation in an adjacent UTRA TDD channels not possible with synchronized and synchronized operation due to different time slot structures.

### 6.6.3 Spurious emissions

Spurious emissions are emissions which are caused by unwanted transmitter effects such as harmonics emission, parasitic emission, intermodulation products and frequency conversion products, but exclude out of band emissions. The spurious emission limits are specified in terms of general requirements inline with SM.329 and a E-UTRA operating band requirement to address UE co-existence.

#### 6.6.3.1 Minimum requirements

The spurious emission limits apply for the frequency ranges that are more than  $\Delta f_{\text{OoB}}$  (MHz) from the edge of the channel bandwidth.

**Table 6.6.3.1-1: Boundary between E-UTRA  $\Delta f_{\text{OoB}}$  and spurious emission domain**

Channel bandwidth	1.4 MHz	1.6 MHz	3.0 MHz	3.2 MHz	5 MHz	10 MHz	15 MHz	20 MHz
$\Delta f_{\text{OoB}}$ (MHz)	[tbd]	[tbd]	[tbd]	[tbd]	10	15	20	25

The spurious emission limits in Table 6.6.3.1-2 apply for all transmitter band configurations (RB) and channel bandwidths.

**Table 6.6.3.1-2: Spurious emissions limits**

Frequency Range	Maximum Level	Measurement Bandwidth
$9 \text{ kHz} \leq f < 150 \text{ kHz}$	-36 dBm	1 kHz
$150 \text{ kHz} \leq f < 30 \text{ MHz}$	-36 dBm	10 kHz
$30 \text{ MHz} \leq f < 1000 \text{ MHz}$	-36 dBm	100 kHz
$1 \text{ GHz} \leq f < 12.75 \text{ GHz}$	-30 dBm	1 MHz

#### 6.6.3.2 Spurious emission band UE co-existence

This clause specifies the requirements for the specified E-UTRA band

Table 6.6.3.2-1: Requirements

E-UTRA Band	Frequency Range	Maximum Level	Measurement Bandwidth	Channel bandwidth
1	-			
2	-			
3	-			
4	-			
5	-			
6	-			
7	-			
8	-			
9	-			
10	-			
11	-			
12	-			
13	-			
14	-			
...				
33	-			
34	-			
35	-			
36	-			
37	-			
38	-			

### 6.6.3.3 Additional spurious emissions

These requirements are specified in terms of an additional spectrum emission requirement.

#### 6.6.3.3.1 Minimum requirement (network signalled value “NS\_05”)

Additional spurious emission requirements are signalled by the network to indicate that the UE shall meet an additional requirement for a specific deployment scenario as part of the cell handover/broadcast message.

When “NS\_05” is indicated in the cell, the power of any UE emission shall not exceed the levels specified in Table 6.6.3.3.1-1.

Table 6.6.3.3.1-1: Additional requirements (PHS)

$\Delta f_{\text{OOB}}$ (MHz)	Channel bandwidth / Spectrum emission limit (dBm)								Measurement bandwidth
	1.4 MHz	1.6 MHz	3.0 MHz	3.2 MHz	5 MHz	10 MHz	15 MHz	20 MHz	
$F_{\text{UL\_low}}$ $F_{\text{UL\_high}}$	-41	-41	-41	-41	-41	-41	-41 <sup>1</sup>	-41 <sup>1</sup>	300 KHz

Note1: Applicable when the edge of the assigned E-UTRA UL channel bandwidth frequency is larger than or equal to 1920MHz + the Channel BW assigned. Operations below this point are for further study.

#### 6.6.3.3.2 Minimum requirements (network signalled)

## 6.7 Transmit intermodulation

The transmit intermodulation performance is a measure of the capability of the transmitter to inhibit the generation of signals in its non linear elements caused by presence of the wanted signal and an interfering signal reaching the transmitter via the antenna.



---

## 7 Receiver characteristics

### 7.1 General

Unless otherwise stated the receiver characteristics are specified at the antenna connector(s) of the UE. For UE(s) with an integral antenna only, a reference antenna(s) with a gain of 0 dBi is assumed for each antenna port(s). UE with an integral antenna(s) may be taken into account by converting these power levels into field strength requirements, assuming a 0 dBi gain antenna. The levels of the test signal applied to each of the antenna connectors shall be as defined in the respective sections below.

All the parameters in clause 7 are defined using the DL reference measurement channel specified in Annex C and fixed power allocation for the RB(s).

The ACS, blocking, spurious emissions and intermodulation requirements in sections 7.5, 7.6, 7.7 and 7.8 are defined for full band width signals i.e. for signals where all resource blocks are allocated for a specific user.

### 7.2 Diversity characteristics

The requirements in Section 7 assume that the receiver is equipped with two Rx port as a baseline. Requirements for 4 ports are FFS.

### 7.3 Reference sensitivity power level

The reference sensitivity power level REFSENS is the minimum mean power applied to both the UE antenna ports at which the mean throughput  $R_{av}$  shall meet or exceed the requirements for the specified reference measurement channel.

#### 7.3.1 Minimum requirements (QPSK)

The throughput  $R_{av}$  shall meet or exceed the minimum requirements specified in table 7.3.1-1 for the specified REFSENS.

**Table 7.3.1-1: Reference sensitivity QPSK**

E-UTRA BAND	Channel bandwidth															
	1.4 MHz		1.6 MHz		3 MHz		3.2 MHz		5 MHz		10 MHz		15 MHz		20 MHz	
	REFSENS / $R_{av}$		REFSENS / $R_{av}$		REFSENS / $R_{av}$		REFSENS / $R_{av}$		REFSENS / $R_{av}$		REFSENS / $R_{av}$		REFSENS / $R_{av}$		REFSENS / $R_{av}$	
1																
2																
3																
4																
5																
6																
7																
8																
9																
10																
11																
12																
13																
14																
...																
33																
34																
35																
36																
37																
38																
Note: 1. The transmitter shall be set to maximum output power level 2. Reference measurement channel is [Annex C QPSK R=1/3]																

### 7.3.2 Maximum Sensitivity Reduction (MSR)

For some operating bands, it is anticipated that the transmitter noise falling in the receive band will be dependant on the channel bandwidth and will degrade the reference sensitivity depending on the operating bandwidth, TX power and FDD or TDD operation configured by the scheduler. This section is for FFS.

### 7.4 Maximum input level

This is defined as the maximum mean power received at the UE antenna port, at which the specified throughput  $R_{av}$  shall meet or exceed the minimum requirements for the specified reference measurement channel.

## 7.4.1 Minimum requirements

The throughput  $R_{av}$  shall meet or exceed the minimum requirements specified in table 7.4.1-1 for the specified wanted signal mean power

**Table 7.4.1-1: Maximum input level**

Rx Parameter	Units	Channel bandwidth							
		1.4 MHz	1.6 MHz	3 MHz	3.2 MHz	5 MHz	10 MHz	15 MHz	20 MHz
Wanted signal mean power	dBm	-25							
$R_{av}$	kbps								
Note:									
1. The transmitter shall be set to 4dB below the supported maximum output power.									
2. Reference measurement channel is [Annex C 64QAM R=3/4]									

## 7.5 Adjacent Channel Selectivity (ACS)

### 7.5.1 Minimum requirements

Adjacent Channel Selectivity (ACS) is a measure of a receiver's ability to receive a E-UTRA signal at its assigned channel frequency in the presence of an adjacent channel signal at a given frequency offset from the centre frequency of the assigned channel. ACS is the ratio of the receive filter attenuation on the assigned channel frequency to the receive filter attenuation on the adjacent channel(s).

The UE shall fulfil the minimum requirement specified in Table 7.5.1-1 for all values of an adjacent channel interferer up to  $-25$  dBm. However it is not possible to directly measure the ACS, instead the lower and upper range of test parameters are chosen in Table 7.5.1-2 and Table 7.5.1-3 where the throughput  $R_{av}$  shall meet or exceed the values specified in Table 7.5.1-1.

**Table 7.5.1-1: Adjacent channel selectivity**

Rx Parameter	Units	Channel bandwidth							
		1.4 MHz	1.6 MHz	3 MHz	3.2 MHz	5 MHz	10 MHz	15 MHz	20 MHz
ACS	dB	33.0	33.0	33.0	33.0	33.0	33.0	30	[27]
$R_{av}$	kbps								

[In the tables below it is assumed that 0dB SNR is required to demodulate the signal with required TP performance and 2dB IM is used.]

Table 7.5.1-2: Test parameters for Adjacent channel selectivity, Case 1

Rx Parameter	Units	Channel bandwidth							
		1.4 MHz	1.6 MHz	3 MHz	3.2 MHz	5 MHz	10 MHz	15 MHz	20 MHz
Wanted signal mean power	dBm	REFSENS + 14 dB							
$P_{\text{Interferer}}$	dBm	REFSENS + [45]dB		REFSENS + [45]dB		REFSENS + [45]dB*	REFSENS + [45]dB*	REFSENS + [42]dB*	REFSENS + [39]dB*
$BW_{\text{Interferer}}$	MHz	1.4	1.6	3	3.2	5	5	5	5
$F_{\text{Interferer}}$ (offset)	MHz	1.4	1.6	3	3.2	5	7.5	10	12.5
Note:									
1. The transmitter shall be set to 4dB below the supported maximum output power.									
2. Reference measurement channel is [Annex C QPSK R=1/3]									
3. *FDD only									

Table 7.5.1-3: Test parameters for Adjacent channel selectivity, Case 2

Rx Parameter	Units	Channel bandwidth							
		1.4 MHz	1.6 MHz	3 MHz	3.2 MHz	5 MHz	10 MHz	15 MHz	20 MHz
Wanted signal mean power	dBm	[-56.0]	[-56.0]	[-56.0]	[-56.0]	[-56.0]	[-56.0]	[-53.0]	[-50.0]
$P_{\text{Interferer}}$	dBm	-25							
$BW_{\text{Interferer}}$	MHz	1.4	1.6	3	3.2	5	5	5	5
$F_{\text{Interferer}}$ (offset)	MHz	1.4	1.6	3	3.2	5	7.5	10	12.5
Note:									
1. The transmitter shall be set to 24dB below the supported maximum output power.									
2. Reference measurement channel is [Annex C QPSK R=1/3]									

## 7.6 Blocking characteristics

The blocking characteristic is a measure of the receiver's ability to receive a wanted signal at its assigned channel frequency in the presence of an unwanted interferer on frequencies other than those of the spurious response or the adjacent channels, without this unwanted input signal causing a degradation of the performance of the receiver beyond a specified limit. The blocking performance shall apply at all frequencies except those at which a spurious response occur.

### 7.6.1 In-band blocking

In-band blocking is defined for an unwanted interfering signal falling into the UE receive band or into the first 15 MHz below or above the UE receive band at which the specified throughput  $R_{av}$  shall meet or exceed the minimum requirements.

#### 7.6.1.1 Minimum requirements

The requirements are specified in terms of a minimum information bit throughput  $R_{av}$  for the parameters specified in Table 7.6.1.1-1. Using this configuration the throughput shall meet or exceed the minimum requirements specified in Table 7.6.1.1-2

Table 7.6.1.1-1: In band blocking parameters

Rx Parameter	Units	Channel bandwidth							
		1.4 MHz	1.6 MHz	3 MHz	3.2 MHz	5 MHz	10 MHz	15 MHz	20 MHz
Wanted signal mean power	dBm	REFSENS + channel bandwidth specific value below							
		3		3		3	3	4	6
$BW_{\text{Interferer}}$	MHz	1.4		3		5	5	5	5
$F_{\text{Interferer}}$ Case 1 (Offset)	MHz	2.1		4.5		7.5	7.5	7.5	7.5
$F_{\text{Interferer}}$ Case 2 (Offset)	MHz	3.5		7.5		12.5	12.5	12.5	12.5
$R_{\text{av}}$	kbps								
Note:									
1. The transmitter shall be set to 4dB below the supported maximum output power.									
2. Reference measurement channel is [Annex C QPSK R=1/3]									

Table 7.6.1.1-2: In-band blocking

E-UTRA band	Parameter	Units	Case 1	Case 2
	$P_{\text{Interferer}}$	dBm	-56	-44
	$F_{\text{Interferer}}$ (Offset)	MHz	$= -BW/2 - F_{\text{offset, case 1}}$ & $= +BW/2 + F_{\text{offset, case 1}}$	$\leq -BW/2 - F_{\text{offset, case 2}}$ & $\geq +BW/2 + F_{\text{offset, case 2}}$
1, 2, 3, 4, 5 7, 8, 9, 10	$F_{\text{Interferer}}$	MHz	$F_{\text{DL\_low}} - 7.5$ to $F_{\text{DL\_high}} + 7.5$ (Note 3)	$F_{\text{DL\_low}} - 15$ to $F_{\text{DL\_high}} + 15$
6	$F_{\text{Interferer}}$	MHz	$F_{\text{DL\_low}} - 7.5$ to $F_{\text{DL\_high}} + 7.5$ (Note 2 & 3)	$F_{\text{DL\_low}} - 15$ to $F_{\text{DL\_high}} + 15$ (Note 3)
Note				
1. The interfering modulated signal is 5MHz E-UTRA signal as described in Annex D for channel bandwidths $\geq 5$ MHz				
2. For each carrier frequency the requirement is valid for two frequencies, the carrier frequencies $-BW/2 - F_{\text{offset, case 1}}$ & $+BW/2 + F_{\text{offset, case 1}}$ .				
3. For Band 6, the unwanted modulated interfering signal does not fall inside the UE receive band, but within the first 15 MHz below or above the UE receive band				

## 7.6.2 Out of-band blocking

Out-of-band band blocking is defined for an unwanted CW interfering signal falling more than 15 MHz below or above the UE receive band. For the first 15 MHz below or above the UE receive band the appropriate in-band blocking or adjacent channel selectivity in sub-clause 7.5.1 and sub-clause 7.6.1 shall be applied.

### 7.6.2.1 Minimum requirements

The requirements are specified in terms of a minimum information bit throughput  $R_{\text{av}}$  for the parameters specified in Table 7.6.2.1-1. Using this configuration the throughput shall meet or exceed the minimum requirements specified in Table 7.6.2.1-2.

For Table 7.6.2.1-2 in frequency range 1, 2 and 3, up to [TBD] exceptions are allowed for spurious response frequencies in each assigned frequency channel when measured using a 1MHz step size. For these exceptions the requirements of clause 7.7 Spurious response are applicable.

For Table 7.6.2.1-2 in frequency range 4, up to [TBD] exceptions are allowed for spurious response frequencies in each assigned frequency channel when measured using a 1MHz step size. For these exceptions the requirements of clause 7.7 Spurious response are applicable.

Table 7.6.2.1-1: Out-of-band blocking parameters

Rx Parameter	Units	Channel bandwidth							
		1.4 MHz	1.6 MHz	3 MHz	3.2 MHz	5 MHz	10 MHz	15 MHz	20 MHz
Wanted signal mean power	dBm	REFSENS + channel bandwidth specific value below							
$R_{av}$	kbps	3	3	3	3	3	3	4	6
Note:									
1. The transmitter shall be set to 4dB below the supported maximum output power.									
2. Reference measurement channel is [Annex C QPSK R=1/3]									

Table 7.6.2.1-2: Out of band blocking

E-UTRA band	Parameter	Units	Frequency			
			range 1	range 2	range 3	range 4
	$P_{Interferer}$	dBm	[-44]	[-30]	[-15]	[-15]
1, 2, 3, 4, 5 6,7, 8, 9, 10	$F_{Interferer}$ (CW)	MHz	$F_{DL\_low} -15$ to $F_{DL\_low} -60$	$F_{DL\_low} -60$ to $F_{DL\_low} -85$	$F_{DL\_low} -85$ to 1 MHz	-
			$F_{DL\_high} +15$ to $F_{DL\_high} +60$	$F_{DL\_high} +60$ to $F_{DL\_high} +85$	$F_{DL\_high} +85$ to +12750 MHz	-
2, 5	$F_{Interferer}$	MHz	-	-	-	$F_{UL\_low} - F_{UL\_high}$
Note:						

## 7.6.3 Narrow band blocking

This requirement is measure of a receiver's ability to receive a E-UTRA signal at its assigned channel frequency in the presence of an unwanted narrow band CW interferer at a frequency, which is less than the nominal channel spacing.

### 7.6.3.1 Minimum requirements

The requirements are specified in terms of a minimum information bit throughput  $R_{av}$  for the parameters specified in Table 7.6.3.1-1.

Table 7.6.3.1-1: Narrow-band blocking

Rx Parameter	Units	Channel bandwidth							
		1.4 MHz	1.6 MHz	3 MHz	3.2 MHz	5 MHz	10 MHz	15 MHz	20 MHz
Wanted signal mean power	dBm	REFSENS + channel bandwidth specific value below							
$P_{Interferer}$ (CW)	dBm	[19]	[19]	[15]	[15]	[13]	[10]	[11]	[13]
$F_{Interferer}$ (Offset)	MHz	[0.9+d]	[1.0+d]	[1.7+d]	[1.8+d]	[2.7+d]	[5.2+d]	[7.7+d]	[10.2+d]
$R_{av}$	Kbps								
Note:									
1. The transmitter shall be set to 4dB below the supported maximum output power.									
2. Reference measurement channel is [Annex C QPSK R=1/3]									
3. FDD only >5 MHz									
4. d= frequency off set. Value of d is TBD.									

## 7.7 Spurious response

Spurious response is a measure of the receiver's ability to receive a wanted signal on its assigned channel frequency without exceeding a given degradation due to the presence of an unwanted CW interfering signal at any other frequency at which a response is obtained i.e. for which the out of band blocking limit as specified in sub-clause 7.6.2 is not met.

### 7.7.1 Minimum requirements

The requirements are specified in terms of a minimum information bit throughput  $R_{av}$  for the parameters specified in Table 7.7.1-1. Using this configuration the throughput shall meet or exceed the minimum requirements specified in table 7.7.1-2.

**Table 7.7.1-1: Spurious response parameters**

Rx Parameter	Units	Channel bandwidth							
		1.4 MHz	1.6 MHz	3 MHz	3.2 MHz	5 MHz	10 MHz	15 MHz	20 MHz
Wanted signal mean power	dBm	REFSENS + channel bandwidth specific value below							
$R_{av}$	kbps	3	3	3	3	3	3	4	6
Note:									
1. The transmitter shall be set to 4dB below the supported maximum output power.									
2. Reference measurement channel is [Annex C QPSK R=1/3 ]									

**Table 7.7.1-2: Spurious Response**

Parameter	Unit	Level
$P_{Interferer}$ (CW)	dBm	-44
$F_{Interferer}$	MHz	Spurious response frequencies

## 7.8 Intermodulation characteristics

Intermodulation response rejection is a measure of the capability of the receiver to receive a wanted signal on its assigned channel frequency in the presence of two or more interfering signals which have a specific frequency relationship to the wanted signal.

### 7.8.1 Wide band Intermodulation

The wide band intermodulation requirement is defined following the same principles using modulated E-UTRA carrier and CW signal as interferer.

#### 7.8.1.1 Minimum requirements

The throughput  $R_{av}$  shall meet or exceed the minimum requirements specified in table 7.8.1-1 for the specified wanted signal mean power in the presence of two interfering signals

Table 7.8.1.1-1: Wide band Intermodulation

Rx Parameter	Units	Channel bandwidth							
		1.4 MHz	1.6 MHz	3 MHz	3.2 MHz	5 MHz	10 MHz	15 MHz	20 MHz
Wanted signal mean power	dBm	REFSENS + channel bandwidth specific value below							
		[9]	[8]	[5]	[5]	3	3	4	6
$P_{\text{Interferer 1 (CW)}}$	dBm	-46							
$P_{\text{Interferer 2 (Modulated)}}$	dBm	-46							
$BW_{\text{Interferer 2}}$		1.4	1.6	3	3.2	5			
$F_{\text{Interferer 1 (Offset)}}$	MHz	-BW/2 - 2.1 / +BW/2 + 2.1	BW/2 - 2.4 / +BW/2 + 2.4	-BW/2 - 4.5 / +BW/2 + 4.5	BW/2 - 4.8 / +BW/2 + 4.8	-BW/2 - 7.5 / +BW/2 + 7.5			
$F_{\text{Interferer 2 (Offset)}}$	MHz	$2 * F_{\text{Interferer 1}}$							
$R_{\text{av}}$	kbps								
Note:									
1. The transmitter shall be set to 4dB below the supported maximum output power.									
2. Reference measurement channel is [Annex C QPSK R=1/3]									
3. The interfering modulated signal is 5MHz E-UTRA signal as described in Annex D for channel bandwidth $\geq 5\text{MHz}$									

## 7.8.2 Narrow band Intermodulation

### 7.8.2.1 Minimum requirements

## 7.9 Spurious emissions

The spurious emissions power is the power of emissions generated or amplified in a receiver that appear at the UE antenna connector.

### 7.9.1 Minimum requirements

The power of any narrow band CW spurious emission shall not exceed the maximum level specified in Table 7.9-1

Table 7.9-1: General receiver spurious emission requirements

Frequency Band	Measurement Bandwidth	Maximum level	Note
$30\text{MHz} \leq f < 1\text{GHz}$	100 kHz		
$1\text{GHz} \leq f \leq 12.75\text{GHz}$	1 MHz		

---

## 8 Performance requirement

### 8.1 General

#### 8.1.1 Dual-antenna receiver capability

8.1.1.1 Simultaneous unicast and MBMS operations

8.1.1.2 Dual-antenna receiver capability in idle mode

---

## Annex A (normative): Measurement channels

A.1 General

A.2 UL reference measurement channels

A.3 DL reference measurement channels

## Annex B (normative): Propagation conditions

### B.1 General

### B.2 Propagation channels

#### B.2.1 Static propagation condition

#### B.2.2 Multi-path fading propagation conditions

The multipath propagation conditions consist of several parts:

- A delay profile in the form of a “tapped delay-line”, characterized by a number of taps at fixed positions on a sampling grid. The profile can be further characterized by the r.m.s. delay spread and the maximum delay spanned by the taps.
- A Doppler spectrum, characterized by a spectrum shape and a maximum Doppler frequency that is determined from the mobile speed
- A set of correlation matrices defining the correlation between the UE and BS antennas in case of multi-antenna systems.

In this clause, a limited set of conditions is defined for each of the parts listed above. Channel models used in performance evaluation are then formed by combining delay profile with a Doppler spectrum, with the addition of correlation properties in case of a multi-antenna scenario.

##### B.2.2.1 Delay profiles

The delay profiles are selected to be representative of *low*, *medium* and *high* delay spread environments. The profiles for *low* and *medium* delay spread are based on the ITU Pedestrian A and Vehicular A channel models respectively, originally defined for the ITU-R evaluation of IMT-2000 [8]. The high delay spread model is based on the Typical Urban model used for GSM [7] and in some of the evaluation work for LTE.

The resulting model parameters are summarized in Table B.2.2.1 and the tapped delay line models are shown in Tables B.2.2.2, B.2.2.3 and B.2.2.4.

The models are defined on a [10 ns] sampling grid. They can be adapted to any desired sampling grid used in a simulation or test setup using the procedure defined to align sampling grids shown in Annex B of TR 25.943 [9].

**Table B.2.2.1-1 Summary of delay profiles for LTE channel models**

Model	Number of channel taps	Delay spread (r.m.s.)	Maximum excess tap delay (span)
Extended Pedestrian A (EPA)	7	45 ns	410 ns
Extended Vehicular A model (EVA)	9	357 ns	2510 ns
Extended Typical Urban model (ETU)	9	991 ns	5000 ns

**Table B.2.2.1-2 Extended Pedestrian A model (EPA)**

Excess tap delay [ns]	Relative power [dB]
0	0.0
30	-1.0
70	-2.0
90	-3.0
110	-8.0
190	-17.2
410	-20.8

**Table B.2.2.1-3 Extended Vehicular A model (EVA)**

Excess tap delay [ns]	Relative power [dB]
0	0.0
30	-1.5
150	-1.4
310	-3.6
370	-0.6
710	-9.1
1090	-7.0
1730	-12.0
2510	-16.9

**Table B.2.2.1-4 Extended Typical Urban model (ETU)**

Excess tap delay [ns]	Relative power [dB]
0	-1.0
50	-1.0
120	-1.0
200	0.0
230	0.0
500	0.0
1600	-3.0
2300	-5.0
5000	-7.0

## B.2.2.2 Doppler spectrum

The Doppler spectrum is modelled using the well known *Clarke* or *Classical Doppler spectrum* [7]. This is the same as the one used for the UTRA performance requirements:

$$p(f) = \begin{cases} \frac{P}{\pi f_{d,\max} \sqrt{1 - \left(\frac{f}{f_{d,\max}}\right)^2}} & \text{if } |f| < f_{d,\max} \\ 0 & \text{if } |f| \geq f_{d,\max} \end{cases} \quad (1)$$

where  $P$  is the net power, and  $f_{d,\max}$  denotes the maximum Doppler frequency, and

$$f_{d,\max} = f_c \frac{v}{c} \quad (2)$$

where  $v$  is the speed of the mobile,  $f_c$  is the carrier frequency and  $c$  is the speed of light.

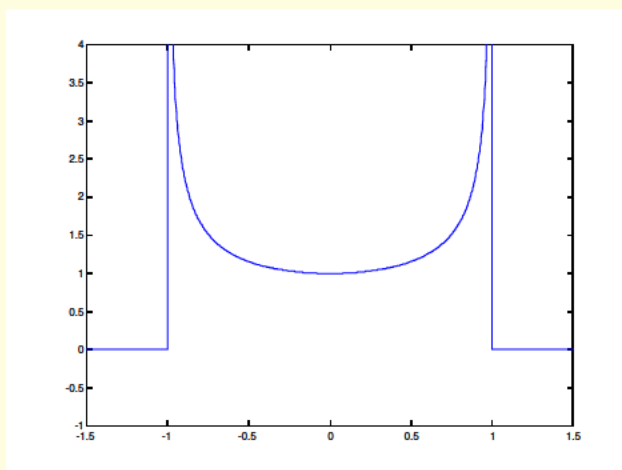

Figure B.2.2.1 The Clarke or Classical Doppler spectrum as a function of normalised Doppler frequency.

When defining the Doppler frequency  $f_{d,max}$  to use for E-UTRA performance requirements, a principle similar to what was used for UTRA can be implemented. Each propagation condition is based on a max Doppler frequency and not on a specific UE speed. A set of three Doppler frequencies spanning the requirement range as *high*, *middle* and *low* Doppler frequencies is selected:

- The LTE requirements for mobility in TR 25.913 [6] state that “Mobility across the cellular network shall be maintained at speeds from 120 km/h to 350 km/h (or even up to 500 km/h depending on the frequency band).” It is also stated that this “...represents a special case such as high speed train environment.” The maximum carrier frequency over all frequency bands is  $f_c = 2690$  MHz and the corresponding maximum Doppler frequency at  $v = 350$  km/h is  $f_D = 843$  Hz.
- There are more common high speed scenarios for moderately high mobile speeds. It is stated in TR 25.913 [6] that high performance should be maintained up to mobile speeds of 120 km/h. The corresponding maximum Doppler frequency for  $f_c = 2690$  MHz is  $f_D = 299$  Hz. Based on this, the *high Doppler frequency* is selected as **300 Hz**.
- TR 25.913 [6] also state that “The E-UTRAN shall support mobility across the cellular network and should be optimized for low mobile speed from 0 to 15 km/h.” For testing purposes, too low mobile speeds are not attractive, since testing times may be very long. The lowest Doppler frequency in UTRA propagation conditions is 5.4 Hz, corresponding to between 2.3 and 7 km/h in the existing frequency bands. Based on this, the *low Doppler frequency* is selected as **5 Hz**.
- An intermediate Doppler frequency can be set at the “logarithmic” average of the 5 and 900 Hz, being 67 Hz. Based on this, the *medium Doppler frequency* is selected as **70 Hz**.

The UE speed that the Doppler frequencies will correspond to will vary between the Operating bands, as shown in Tables B.2.2.5 and B.2.2.6 (informative), where the carrier frequencies at the centre of each uplink and downlink band are used to derive the corresponding UE speeds.

Table B.2.2.5 Uplink Doppler frequencies and corresponding UE speeds (informative).

Operating Band	UL Frequencies UE transmit, Node B receive	Propagation condition (Doppler) Corresponding UE speed [km/h]		
		Low (5 Hz)	Mid (70 Hz)	High (300 Hz)
1	1920 - 1980 MHz	2.8	39	166
2	1850 - 1910 MHz	2.9	40	172
3	1710 - 1785 MHz	3.1	43	185
4	1710 - 1755 MHz	3.1	44	187
5	824 - 849 MHz	6.5	90	387
6	830 - 840 MHz	6.5	91	388
7	2500 - 2570 MHz	2.1	30	128
8	880 - 915 MHz	6.0	84	361
9	1749.9 - 1784.9 MHz	3.1	43	183
10	1710 - 1770 MHz	3.1	43	186

Table B.2.2.6 Downlink Doppler frequencies and corresponding UE speeds (informative).

Operating Band	UL Frequencies UE transmit, Node B receive	Propagation condition (Doppler) Corresponding UE speed [km/h]		
		Low (5 Hz)	Mid (70 Hz)	High (300 Hz)
1	2110 - 2170 MHz	2.5	35	151
2	1930 - 1990 MHz	2.8	39	165
3	1805 - 1880 MHz	2.9	41	176
4	2110 - 2155 MHz	2.5	35	152
5	869 - 894 MHz	6.1	86	368
6	875 - 885 MHz	6.1	86	368
7	2620 - 2690 MHz	2.0	28	122
8	925 - 960 MHz	5.7	80	344
9	1844.9 - 1879.9 MHz	2.9	41	174
10	2110 - 2170 MHz	2.5	35	151

Table B.2.2.7 Doppler frequencies and corresponding UE speeds for TDD operating band (informative).

Operating Band	UL Frequencies UE transmit, Node B receive	Propagation condition (Doppler) Corresponding UE speed [km/h]		
		Low (5 Hz)	Mid (70 Hz)	High (300 Hz)
33	1900 – 1920 MHz	2.8	40	170
	2010 – 2025 MHz	2.7	37	161
34	1850 – 1910 MHz	2.9	40	172
	1930 – 1990 MHz	2.8	39	165
36	1910 – 1930 MHz	2.8	39	169
37	2570 – 2620 MHz	2.1	29	125

## B.2.2.3 Multi-Antenna channel models

### B.2.2.3.1 Background

The LTE MIMO channel model is defined by applying the same correlation matrix to the multipaths defined in Section B.2.2.1. Three types of correlations are defined namely high, medium and low correlation. The low correlation matrix will have no correlation and simply becomes the identity matrix. The following discussion then concentrates on the high and medium correlation types. No particular antenna configurations are provided although it is implicitly assumed that linear spatial arrays of 1, 2, or 4 elements are used at eNB and UE. The correlation matrices are specified via an eNB spatial correlation between adjacent antennas  $\alpha$  and a UE spatial correlation between adjacent antennas  $\beta$ .

For the 2 x 2 LTE channel model, the antenna configurations for high and medium correlation types are provided as follows:

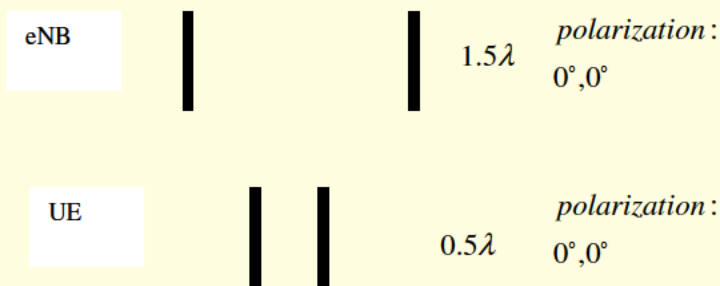

Figure B.2.2.1 High correlation antenna configuration

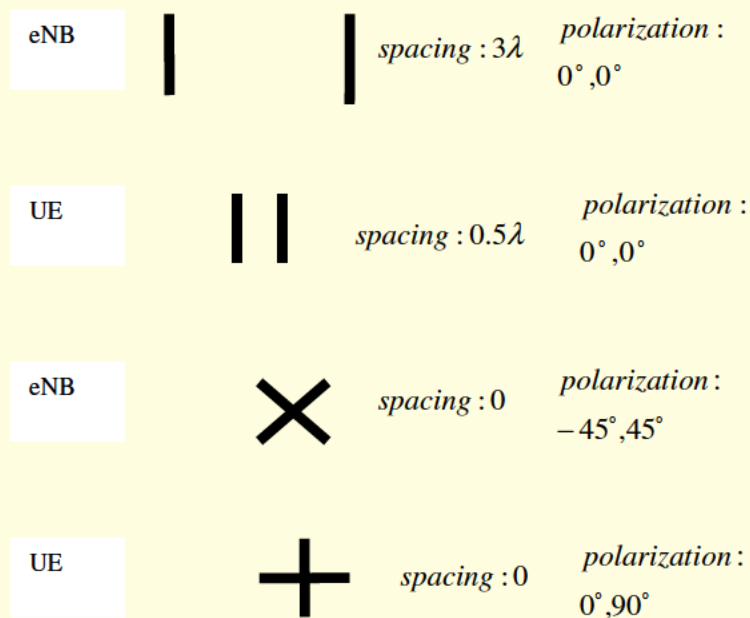

Figure B.2.2.2 Medium correlation antenna configuration

The correlation matrix for the eNB with two antennas is represented as follows:

$$R_{eNB} = \begin{pmatrix} 1 & \alpha \\ \alpha^* & 1 \end{pmatrix}$$

and with one antenna, the correlation matrix for the eNB reduces to:

$$R_{eNB} = 1$$

The correlation matrix for UE is represented as follows:

$$R_{UE} = \begin{pmatrix} 1 & \beta \\ \beta^* & 1 \end{pmatrix}$$

The parameters  $\alpha$  and  $\beta$  are defined in Table B.2.2.1 and define the spatial correlation between the antennas at the eNB and UE.

We define the channel spatial correlation matrix for 2x2 case,  $R_{spat}$ , as:

$$R_{spat} = R_{eNB} \otimes R_{UE} = \begin{bmatrix} 1 & \alpha \\ \alpha^* & 1 \end{bmatrix} \otimes \begin{bmatrix} 1 & \beta \\ \beta^* & 1 \end{bmatrix} = \begin{bmatrix} 1 & \beta & \alpha & \alpha\beta \\ \beta^* & 1 & \alpha\beta^* & \alpha \\ \alpha^* & \alpha^*\beta & 1 & \beta \\ \alpha^*\beta^* & \alpha^* & \beta^* & 1 \end{bmatrix}$$

and for the 1x2 case:

$$R_{spat} = R_{UE} = \begin{bmatrix} 1 & \beta \\ \beta^* & 1 \end{bmatrix}$$

For cases with more antennas at either eNB or UE or both, the channel spatial correlation matrix can still be expressed as the Kronecker product of  $R_{eNB}$  and  $R_{UE}$  according to  $R_{spat} = R_{eNB} \otimes R_{UE}$ . Due to the size of  $R_{spat}$  for these cases the explicit [elements have](#) not be given here.

The  $\alpha$  and  $\beta$  for different correlation types are given in Table B.2.2.1.

Table B.2.2.1

Low correlation		Medium Correlation		High Correlation	
$\alpha$	$\beta$	$\alpha$	$\beta$	$\alpha$	$\beta$
0	0	0.3 [- 0.2016  +0.6132i 1]	0.9 [- 0.4193+ 0.2400i 1]	0.9 [0.5297 + 0.7013i]	0.9 [-0.4193 + 0.2400i]

Based on the antenna configurations shown in Figures B.2.2.1 and B.2.2.2, the polarization matrices for the high and medium correlation types are

$$\Gamma_{high} = \begin{pmatrix} 1 & 1 & 1 & 1 \\ 1 & 1 & 1 & 1 \\ 1 & 1 & 1 & 1 \\ 1 & 1 & 1 & 1 \end{pmatrix}$$

$$\Gamma_{medium} = \begin{pmatrix} 1 & 0 & 0.7264 & 0 \\ 0 & 1 & 0 & -0.7264 \\ 0.7264 & 0 & 1 & 0 \\ 0 & -0.7264 & 0 & 1 \end{pmatrix}$$

The final correlation matrix  $R$  is determined by extracting those elements which are the products of the spatial correlation coefficient and the polarization correlation coefficient with the same Tx and Rx antenna index where

$$R = R_{UE} \otimes \Gamma \otimes R_{eNB}$$

and it can be further shown that the final correlation matrix can be obtained from

$$R = \Gamma \bullet (R_{UE} \otimes R_{eNB}) = \Gamma \bullet R_{spat}$$

where  $\bullet$  is the matrix element-wise product.

### B.2.2.3.2 Correlation Matrix Defintions

The correlation matrices for high correlation for 1x2 and 2x2 respectively are:

$$R_{high} = \begin{pmatrix} [1] & [1] \\ [1] & [1] \end{pmatrix} R_{high} = \begin{pmatrix} 1 & 0.9 \\ 0.9 & 1 \end{pmatrix}$$

$$R_{high} = \begin{pmatrix} 1 & 0.9 & 0.9 & 0.81 \\ 0.9 & 1 & 0.81 & 0.9 \\ 0.9 & 0.81 & 1 & 0.9 \\ 0.81 & 0.9 & 0.9 & 1 \end{pmatrix}$$

The correlation matrices for medium correlation for 2x2 is:

$$R_{medium} = \begin{pmatrix} [1] & [0.5] \\ [0.5] & [1] \end{pmatrix}$$

$$R_{medium} = \begin{pmatrix} [1] & [0] & [0.7264] & [0] \\ [0] & [1] & [0] & [-0.7264] \\ [0.7264] & [0] & [1] & [0] \\ [0] & [-0.7264] & [0] & [1] \end{pmatrix} R_{medium} = \begin{pmatrix} 1 & 0.9 & 0.3 & 0.27 \\ 0.9 & 1 & 0.27 & 0.3 \\ 0.3 & 0.27 & 1 & 0.9 \\ 0.27 & 0.3 & 0.9 & 1 \end{pmatrix}$$

The correlation matrices for low correlation is (no correlation) for 1x2 and 2x2 respectively are:

$$R_{low} = \begin{pmatrix} 1 & 0 \\ 0 & 1 \end{pmatrix}$$

$$R_{low} = \begin{pmatrix} 1 & 0 & 0 & 0 \\ 0 & 1 & 0 & 0 \\ 0 & 0 & 1 & 0 \\ 0 & 0 & 0 & 1 \end{pmatrix}$$

### B.2.2.3.3 Correlation Matrix Application

### B.2.2.4 Combinations of channel model parameters

A set of baseline combinations of channel model parameters are introduced. These offer a selection from the range of parameters, in order to reduce the total number of channel models to be used in simulating and defining the LTE receiver performance.

Delay spread	Doppler frequency	Model	Comment
[Low]	[Low]	[EPA 5Hz]	[Low delay spread model representing small cell and indoor cases.]
[Medium]	[Low]	[EVA 5Hz]	
[Medium]	[Medium]	[EVA 70Hz]	
[High]	[Medium]	[ETU 70Hz]	[Represents high delay spread environments, with a delay span of the same order as the cyclic prefix.]
[High]	[High]	[ETU 300Hz]	
TBD	[High]	TBD	[A high speed train scenerio is for further study.]

## Annex C (normative): Downlink Physical Channels

- C.1 General
- C.2 Set-up
- C.3 Connection

## Annex D (normative): Characteristics of the interfering signal

### D.1 General

When the channel band width is wider or equal to 5MHz, a modulated 5MHz full band width E-UTRA down link signal and CW signal are used as interfering signals when RF performance requirements for E-UTRA UE receiver are defined. For channel band widths below 5MHz, the band width of modulated interferer should be equal to band width of the received signal.

### D.2 Interference signals

Table D.2-1 describes the modulated interferer for different channel band width options.

**Table D.2-1: Description of modulated E-UTRA interferer**

	Channel bandwidth							
	1.4 MHz	1.6 MHz	3 MHz	3.2 MHz	5 MHz	10 MHz	15 MHz	20 MHz
RB	6	7	15	16	25	50	75	100
BW <sub>Interferer</sub>	1.4 MHz	1.6 MHz	3 MHz	3.2 MHz	5 MHz	5 MHz	5 MHz	5 MHz

## Annex E (normative): Environmental conditions

### E.1 General

This normative annex specifies the environmental requirements of the UE. Within these limits the requirements of the present documents shall be fulfilled.

### E.2 Environmental

The requirements in this clause apply to all types of UE(s).

#### E.2.1 Temperature

The UE shall fulfil all the requirements in the full temperature range of:

**Table E.2.1-1**

+15°C to +35°C	for normal conditions (with relative humidity of 25 % to 75 %)
-10°C to +55°C	for extreme conditions (see IEC publications 68-2-1 and 68-2-2)

Outside this temperature range the UE, if powered on, shall not make ineffective use of the radio frequency spectrum. In no case shall the UE exceed the transmitted levels as defined in clause 6.2 for extreme operation.

#### E.2.2 Voltage

The UE shall fulfil all the requirements in the full voltage range, i.e. the voltage range between the extreme voltages.

The manufacturer shall declare the lower and higher extreme voltages and the approximate shutdown voltage. For the equipment that can be operated from one or more of the power sources listed below, the lower extreme voltage shall not be higher, and the higher extreme voltage shall not be lower than that specified below.

**Table E.2.2-1**

Power source	Lower extreme voltage	Higher extreme voltage	Normal conditions voltage
AC mains	0,9 * nominal	1,1 * nominal	nominal
Regulated lead acid battery	0,9 * nominal	1,3 * nominal	1,1 * nominal
Non regulated batteries:			
Leclanché	0,85 * nominal	Nominal	Nominal
Lithium	0,95 * nominal	1,1 * Nominal	1,1 * Nominal
Mercury/nickel & cadmium	0,90 * nominal		Nominal

Outside this voltage range the UE if powered on, shall not make ineffective use of the radio frequency spectrum. In no case shall the UE exceed the transmitted levels as defined in clause 6.2 for extreme operation. In particular, the UE shall inhibit all RF transmissions when the power supply voltage is below the manufacturer declared shutdown voltage.

## E.2.3 Vibration

The UE shall fulfil all the requirements when vibrated at the following frequency/amplitudes.

**Table E.2.3-1**

<b>Frequency</b>	<b>ASD (Acceleration Spectral Density) random vibration</b>
5 Hz to 20 Hz	0,96 m <sup>2</sup> /s <sup>3</sup>
20 Hz to 500 Hz	0,96 m <sup>2</sup> /s <sup>3</sup> at 20 Hz, thereafter –3 dB/Octave

Outside the specified frequency range the UE, if powered on, shall not make ineffective use of the radio frequency spectrum. In no case shall the UE exceed the transmitted levels as defined in TS 36.101 for extreme operation.

