

UNITED STATES PATENT AND TRADEMARK OFFICE

BEFORE THE PATENT TRIAL AND APPEAL BOARD

IMPERATIVE CARE, INC.,
Petitioner,

v.

INARI MEDICAL, INC.,
Patent Owner.

Case No. IPR2025-01025
U.S. Patent No. 11,974,910

SUPPLEMENTAL DECLARATION OF BRIAN BROWN

TABLE OF CONTENTS

I. INTRODUCTION1

II. BACKGROUND AND QUALIFICATIONS4

III. BASES OF MY OPINION.....8

 A. Materials Considered.....8

 B. Relevant Legal Principles.....8

IV. SUMMARY OF OPINIONS11

V. THE '910 PATENT11

 A. Overview11

 B. Prosecution History21

 C. Person of Ordinary Skill in the Art24

 D. Claim Construction.....25

VI. REFERENCES25

 A. Garrison25

 B. Laub.....35

 C. Aklog.....38

VII. GROUNDS 1-3: THE COMBINATION OF GARRISON AND LAUB AND/OR AKLOG DOES NOT RENDER OBVIOUS ANY OF CLAIMS 1-6, 8, 11-15, OR 18-2041

 A. A POSITA Would Not Have Been Motivated to Modify Garrison to Arrive at Petitioner’s Purported Arrangement Adding Two Valves to Figure 33 of Garrison46

 B. A POSITA Would Not Have Modified Garrison’s System to Treat PE or to Include a Second Inner Catheter Having a “Size of 16 French or Greater” Because Petitioner’s References Teach that Such a System Would Endanger the Patient Without Blood Return72

C. A POSITA Would Not Have Modified Garrison to Include a Catheter Having a Second Inner Catheter With “Size of 16 French or Greater” Because Such a Modification Would Prevent Garrison’s System from Being Positioned in The Cerebral Vasculature85

VIII. GROUNDS 4-9: THE COMBINATIONS OF GARRISON AND LAUB AND/OR AKLOG FURTHER IN VIEW OF HARTLEY OR PASHA AKLOG DOES NOT RENDER OBVIOUS ANY OF CLAIMS 3, 6-7, 12, 18, OR 2090

IX. SECONDARY CONSIDERATIONS90

X. CONCLUSION.....90

I, **Brian Brown**, declare as follows:

I. INTRODUCTION

1. My name is Brian Brown. I have been retained by counsel for Patent Owner Inari Medical, Inc., (“Patent Owner” or “Inari”) as an independent expert consultant in this *inter partes* review (IPR) proceeding, IPR2025-01025, concerning U.S. Patent 11,974,910 (“the ’910 Patent”; EX1001), pending before the U.S. Patent and Trademark Office, Patent Trial and Appeal Board (“Board”).
2. I previously provided a declaration (EX2003) in support of Patent Owner’s Preliminary Response (“Opening Declaration”) which I incorporate by reference. In my Opening Declaration, I addressed certain aspects of the challenged claims and the prior art. This Supplemental Declaration is meant to supplement and clarify points in my Opening Declaration, as well as to respond to the Institution Decision and arguments raised in Petitioner’s Reply to Patent Owner’s Preliminary Response. As I explained in my Opening Declaration, I understand that Imperative Care, Inc. (“Petitioner” or “Imperative”) has filed a petition for *inter partes review* before the Board asserting:

Ground 1: Claims 1-6, 8, 11-15, and 18-20 of the ’910 Patent are unpatentable under 35 U.S.C. § 103 as obvious over U.S. Patent Application Publication No. 2015/0173782 to Garrison et al.

(EX1006; “Garrison”) in combination with U.S. Patent Application Publication No. 2017/0043066 (EX1012; “Laub”);

Ground 2: Claims 1-6, 8, 11-15, and 18-20 of the ’910 Patent are unpatentable under 35 U.S.C. § 103 as obvious over Garrison in combination with U.S. Patent No. 8,734,374 to Aklog (EX1005; “Aklog”);

Ground 3: Claims 1-6, 8, 11-15, and 18-20 of the ’910 Patent are unpatentable under 35 U.S.C. § 103 as obvious over Garrison in combination with Laub and Aklog;

Ground 4: Claims 6-7 and 20 of the ’910 Patent are unpatentable under 35 U.S.C. § 103 as obvious over Garrison in combination with Laub and U.S. Patent Application Publication No. 2003/0116731 to Hartley (EX1008; “Hartley”);

Ground 5: Claims 6-7 and 20 of the ’910 Patent are unpatentable under 35 U.S.C. § 103 as obvious over Garrison in combination with Aklog and Hartley;

Ground 6: Claims 6-7 and 20 of the ’910 Patent are unpatentable under 35 U.S.C. § 103 as obvious over Garrison in combination with Laub, Aklog, and Hartley;

Ground 7: Claims 3, 12, and 18 of the '910 Patent are unpatentable under 35 U.S.C. § 103 as obvious over Garrison in combination with Laub and non-patent literature by Ahmed Pasha et al. and titled "Successful Management of Acute Massive Pulmonary Embolism Using Angiovac Suction Catheter Technique in a Hemodynamically Unstable Patient, 15 Cardiovasc. Revasc." (EX1049; "Pasha");

Ground 8: Claims 3, 12, and 18 of the '910 Patent are unpatentable under 35 U.S.C. § 103 as obvious over Garrison in combination with Aklog and Pasha; and

Ground 9: Claims 3, 12, and 18 of the '910 Patent are unpatentable under 35 U.S.C. § 103 as obvious over Garrison in combination with Aklog, Laub, and Pasha.

I have been asked by counsel for Patent Owner to opine on the patentability of the Claims of the '910 Patent.

3. Along with my years of education, research, and experience, my opinions are based on investigation and study of relevant materials. The materials that I evaluated in support of this Declaration include all exhibits cited in this Declaration and in the Petition.

4. I may rely upon these materials, my knowledge and experience, and/or additional materials to rebut arguments raised by Petitioner. Further, I may also consider additional documents and information in forming any necessary opinions, including documents that may not yet have been provided to me.
5. My analysis of the materials produced in this matter is ongoing, and I will continue to review any new material as it is provided. This Declaration represents only those opinions I have formed to date. I reserve the right to revise, supplement, and/or amend my opinions stated herein based on new information and on my continuing analysis of the materials already provided.
6. My work in this case is being billed at my normal hourly consulting rate, with reimbursement for actual expenses. My compensation is not related to the outcome of this proceeding. I have no personal interest in the outcome of the case.

II. BACKGROUND AND QUALIFICATIONS

7. My qualifications for forming the opinions set forth in this Declaration are summarized here and explained in more detail in my curriculum vitae, which I provide as a first attachment to my Declaration.
8. I received a Bachelor of Science in Mechanical Engineering from North Dakota State University, with an emphasis on electromechanical automation. As part of my studies, I took classes covering many different engineering areas

Declaration of Brian Brown

including chemistry, physics, advanced mathematics, statistics, software engineering and architecture, statics, dynamics, thermodynamics, robotics, technical writing, material science, fluid dynamics and engineering design. After my studies, I joined Hutchinson Technology as a machine design engineer. After a few years at Hutchinson, I joined Boston Scientific/SciMED in 1990 and began working with their medical device product lines, including stents and cardiovascular implants.

9. Beginning with my time at SciMED, I have over 30 years of research and development experience working in the cardiovascular and medical device industries across a wide variety of application areas including development of neurovascular, cardiovascular, peripheral vascular, and pulmonary aspiration thrombectomy devices.
10. For 24 years, I served in various roles at SciMED Life Systems and Boston Scientific, including multiple research and development engineering positions in various application areas including catheters, stents, guidewires, thrombectomy systems, and cardiovascular implants. For my final 10 years at Boston Scientific, I served as the global vice president of R&D Interventional Cardiology, where I was tasked to direct worldwide cardiovascular research and development activities for accelerated launches of implantable stents,

drug delivery technologies, structural heart devices, disposable catheters, and adjunctive products.

11. Starting in 1991, in collaboration with Possis Medical and SciMED Life Systems, I designed and developed a drive unit to supply high pressure water jet and aspiration to a thrombectomy catheter. From 1992 to 1993, as part of my work, I developed and patented several thrombus removal catheters designed for aspiration, irrigation, and mechanical interaction with thrombi.
12. I also held various leadership roles at medical device and diagnostics companies, including Chief Technology Officer at OvaGene Oncology and Vice President of R&D and Operations at both Cogentix Medical, Inc. and Sunshine Heart, Inc, focused on advancing the medical device and diagnostics industries.
13. For the past 6 years, I have served as a technical consultant for various early-stage medical device companies as the founder and President of Brown-Tech, LLC, including QXMedical, Peytant Solutions, and CardioMech. I am also one of the founding partners for Northern Nitinol, LLC, which is a company that focuses on nitinol design and prototyping for medical device components.
14. I was the two-time recipient of the Boston Scientific Patent of the Year award, recognized as one of Minnesota's leading inventors by Twin City Business Magazine in 2013, elected to College of Fellows, American Institute for

Medical and Biological Engineering, and served as an Advisor to the University of Minnesota Office of Technology Commercialization. I also served as a mentor to students enrolled in the University of Minnesota Design of Medical Device program.

15. I am a named inventor on approximately sixty issued U.S. medical device patents covering a wide variety of technologies, including two aspiration thrombectomy patents and several others on stent geometries, nitinol, balloon catheters, infusion catheters, and ePTFE processing. I am an inventor of U.S. Patent No. 5,419,774 on a thrombus extraction device for quickly removing thrombus from a saphenous vein graft, and U.S. Patent No. 5,417,703 on an intravascular device for removing vascular occlusion material.
16. During my career, I developed a range of medical devices from low profile neurovascular catheters for the treatment of neurovascular disease and embolic stroke to large profile catheters for the treatment of peripheral vascular disease (PVD), deep vein thrombosis (DVT), pulmonary embolism (PE), and structural heart disease (SHD). Larger profile catheters were used for the treatment of PVD, DVT, PE, and SHD to accommodate the delivery of larger therapeutic devices (balloons, stents, valves) to the large diameter vessels. Many of the catheter systems I developed included hemostasis valves, of various designs, on the proximal end to facilitate the introduction of ancillary devices

(guidewires, snares, ultrasound, etc.) and the coaxial introduction of a catheter within a catheter to cross challenging anatomy or to extend to distal treatment sites.

III. BASES OF MY OPINION

A. Materials Considered

17. The opinions included in this Declaration are based on the documents I reviewed, my professional judgment, and my education and experience.
18. In forming the opinions expressed in this Declaration, I reviewed all the materials listed in the second attachment I have provided to my Declaration, and any other material I refer to in this Declaration in support of my opinions.

B. Relevant Legal Principles

19. I am not an attorney but, in preparing and forming my opinions, I have been informed of certain legal principles. I have applied my understanding of those principles and taken them into account when forming the opinions I describe. My understanding of the relevant legal principles is summarized below.
20. I understand that claim terms are generally given their ordinary and customary meaning as understood by a person of ordinary skill in the art at the time of the invention when read in the context of the specification and prosecution history, unless a patentee sets out a different definition or clearly disavows claim scope.

21. I further understand that extrinsic evidence such as expert and inventor testimony, dictionaries, and learned treatises can help determine the meaning of claim terms, although that evidence is less significant than the claims, specification, and prosecution history, and the extrinsic evidence cannot be used to contradict the intrinsic evidence.
22. I have been informed that Petitioner bears the burden of proving unpatentability by a preponderance of evidence. I have been told that this means that Petitioner must prove that more likely than not that the Claims of the '910 Patent are obvious over Garrison in combination with one or more of Laub, Aklog, Hartley, and Pasha.
23. I understand that my opinions regarding patentability are from the viewpoint of a person having ordinary skill in the field of the technology of the patent as of the time of the invention. For the purposes of this Declaration, I have assumed that date is the earliest priority date of the '910 Patent, August 13, 2018. Petitioner also applied August 13, 2018, as the priority date for the '910 Patent. Petition, pg.18.
24. I understand that if the differences between the claimed invention and the prior art are such that the claimed invention as a whole would have been obvious before the effective filing date of the claimed invention to a person having

ordinary skill in the art to which the claimed invention pertains, the claimed invention is obvious.

25. I understand there are four fact-based inquiries involved in determining patent obviousness. These include: (1) the scope and content of the prior art; (2) the differences between the claimed invention and the prior art; (3) the level of ordinary skill in the art; and (4) objective indicia of non-obviousness. I have been informed that examples of objective indicia include unexpected results, commercial success of the invention, whether the invention satisfied a long felt need in the industry, failure of others to find a solution to the problem at hand, commercial acquiescence via licensing, professional approval, unexpected results, and copying and praise by infringers.
26. I understand that even if all limitations of a claimed invention are disclosed by the prior art combination, the patent challenger must demonstrate an apparent reason to combine the known elements in the fashion of the patent claim at issue and that a person of ordinary skill in the art would have reasonable expectation of success in pursuing that combination.
27. I understand that a prior art reference teaches away from a proposed modification when a person of ordinary skill in the art would be discouraged from following the path set out in the reference or would be led in a direction divergent from the path followed by and claimed in the patent.

IV. SUMMARY OF OPINIONS

28. For the reasons I discuss below, I believe that the Claims of the '910 Patent are not rendered obvious by any combination of the prior art asserted in the Petition.

V. THE '910 PATENT

A. Overview

29. Thrombi and emboli are blood clots that cause blockages (also called occlusions) of blood vessels or arteries. Blocking blood flow results in oxygen deprivation of tissues that results in tissue death. Clot blockages can cause many very serious health conditions if the clot is located in a critical blood vessel, including stroke (blocking blood flow to or from the brain), pulmonary embolism (blocking the flow of deoxygenated blood to the lungs), heart attacks (blocking blood flow to the heart), and other serious conditions. Venous thromboembolism (VTE) and the related health conditions, e.g., deep vein thrombosis (DVT) and pulmonary embolism (PE), are a huge problem, affecting approximately 900,000 people in the United States every year. (See <https://www.cdc.gov/blood-clots/data-research/factsstats/index.html>.) Venous thromboembolism is, in fact, a leading cause of preventable hospital deaths in the United States and worldwide, causing 60,000-100,000 deaths per year in the United States alone. (See <https://www.cdc.gov/blood-clots/data-research/factsstats/index.html>.)

30. A blood clot is essentially a living polymer, comprising a matrix of intertwined and cross-linked strands within which are situated red and white blood cells, platelets and numerous other proteins and components. The mechanical properties of a clot are influenced by the relative percentages of other materials and red blood cells, and clots that are highly fibrous (and highly organized) and have lower red blood cell content tend to be firmer and more cohesive than clots of a higher red cell content. Such clots have also been found to have a higher coefficient of friction, or in other words to be “stickier.” These firm and sticky clots can be challenging to remove from a vessel.
31. Clots that are less organized and with a high red cell content have been found to be less cohesive, more friable (i.e., more easily crumbled) and to have a lower coefficient of friction than the more organized and stickier clots previously described. Fresher (younger) clots are typically characterized as more friable, softer and less organized, whereas older (mature) clots are characterized as more organized, firmer, and stickier. These properties mean that fresher and softer clots may be easier to dislodge from the site of occlusion.
32. DVT is a type of blood clot (thrombus) that typically forms in the deep veins of a limb, such as the leg. EX1001, 1:46-51. Thromboembolism occurs when part or all of a thrombus breaks away from the blood vessel wall. This blood clot (now called an embolus) is then carried in the direction of blood flow.

When the embolus travels from the vein towards the heart and then lungs, a PE may result if such embolus lodges in an artery or branch thereof of the lungs. *Id.* at 1:57-67. Because of their location and how they are formed DVT and PE clots tend to be larger, older, more highly organized, and more fibrous than arterial clots, such as clots in the cerebral vasculature that cause strokes.

33. Treatment of PE and DVT has long been a challenge, with the existing methods of treatment failing to significantly improve patient mortality rates over the last five decades. For example, PE and DVT have traditionally been treated with drugs, e.g., anticoagulants (also called blood thinners), streptokinase (also called SK manufactured by pharmaceutical makers including GSK and BBT Biotech GmbH), urokinase (also called Abbokinase or Kinlytic, manufactured by companies including Abbott Laboratories), or other drugs in a class of agents called “thrombolytics” (or just “lytics”) that break down and dissolve the clot over hours or days, but do not physically remove the clot material from the body. EX1001, 2:26-32. Doctors can treat patients with lytics by introducing the drugs through an IV line or, more preferably for many cases, applying the lytics at the site of the clot using a perfusion catheter placed at the clot. To this day, the use of either anticoagulants or lytics (particularly for certain types of more acute cases) are the most common and recommended treatments for PE and DVT in guidelines by medical organizations

such as the American College of Chest Physicians, European Society of Cardiology, American Heart Association, and the Society of Interventional Radiology.

34. Lytics have many disadvantages. First, they can take many hours to work. EX1001, 2:28-29. Second, because the clots are not actually removed from the body, portions of the clot can break off and travel to a different location within the body rather than being eliminated entirely. Additionally, using lytics can cause hemorrhages and serious risks of death, necessitating ICU stays for treatments and monitoring. *Id.* at 2:30-32. Lytic treatments also are very expensive, as they require longer hospital stays, and they cannot be used for many patients because of conditions related to increased risk of bleeding (e.g., active bleeding, recent brain bleed/hemorrhage, recent brain or spine surgery, severe hypertension, severe kidney disease, etc.).
35. Anticoagulant drugs also have many disadvantages. The side effects include bleeding risk and loss of bone density. Anticoagulants also are not effective against existing clots, merely preventing clots from forming or continuing to form (to some degree).
36. The '910 Patent is directed to clot treatment systems for aspirating clot material—such as PE—from the vasculature of a patient that offer significant benefits over such conventional treatments. EX1001, 4:17-19. For example, the

'910 Patent describes various aspiration systems that generate (pre-charge or store) negative (vacuum) pressure before applying the vacuum to an aspiration catheter positioned near clot material (e.g., PE or DVT) in a patient's blood vessel to generate large suction forces (and corresponding fluid flow velocities) needed to effectively aspirate and remove the clot material from the patient. *Id.* at 4:34-50. The generated suction forces and corresponding fluid flow velocities are greater than conventional systems allowing the aspiration systems to more effectively remove the clot material, even when the clot material is strongly lodged or attached within the blood vessel in the instance of, for example, chronic PE or chronic DVT. *Id.* at 4:42-47 & 10:14-27.

37. I understand that Patent Owner has come to call their methodology of applying pre-charged vacuum "whoosh," so named based on the sound the catheter system makes when the pre-charged vacuum is applied to the catheter to aspirate blood and clot material.
38. The '910 Patent claims clot treatment systems for removing a PE from the vasculature of a patient including a first clot aspiration assembly and a second clot aspiration assembly. EX1001, cls.1 & 11. The first clot aspiration assembly includes a first catheter and a first pressure source for generating suction in (i.e., aspirating) the first catheter, and the second clot aspiration assembly similarly includes a second catheter and a second pressure source for

generating suction in (i.e., aspirating) the second catheter. *Id.* The second catheter is advanceable (i.e., insertable) through the first catheter. *Id.* The second catheter has a distal portion that is positioned proximate the PE in the vasculature of the patient. *Id.*

39. The second pressure source is connected to the second catheter via a fluid control device (e.g., stopcock) that is closed when vacuum pressure is generated by the second pressure source and subsequently opened to apply the built-up (i.e., pre-charged) vacuum to the second catheter to aspirate blood and at least a portion of the PE into the second catheter and out of the patient. *Id.* That is, the second clot aspiration assembly is arranged and operated to apply a pre-charged vacuum through the second catheter to effectively remove the PE. The second catheter of the second clot aspiration assembly has a size of 16 French or greater to, for example, facilitate high flow rates that effectively aspirate the PE even when it is strongly adhered within the blood vessel. *Id.* at cls. 1 & 11, 9:36-10:27. In Claim 1, the first clot aspiration assembly is similarly connected to the first catheter via a fluid control device that is closed when vacuum pressure is generated and built up by the first pressure source and subsequently opened to apply the built-up vacuum to the first catheter. *Id.* at cl. 1.

40. Figure 11 of the '910 Patent shows such a system for treating PE having a first clot aspiration assembly 20 and a second clot aspiration assembly 30 advanced through the first clot aspiration assembly 20:

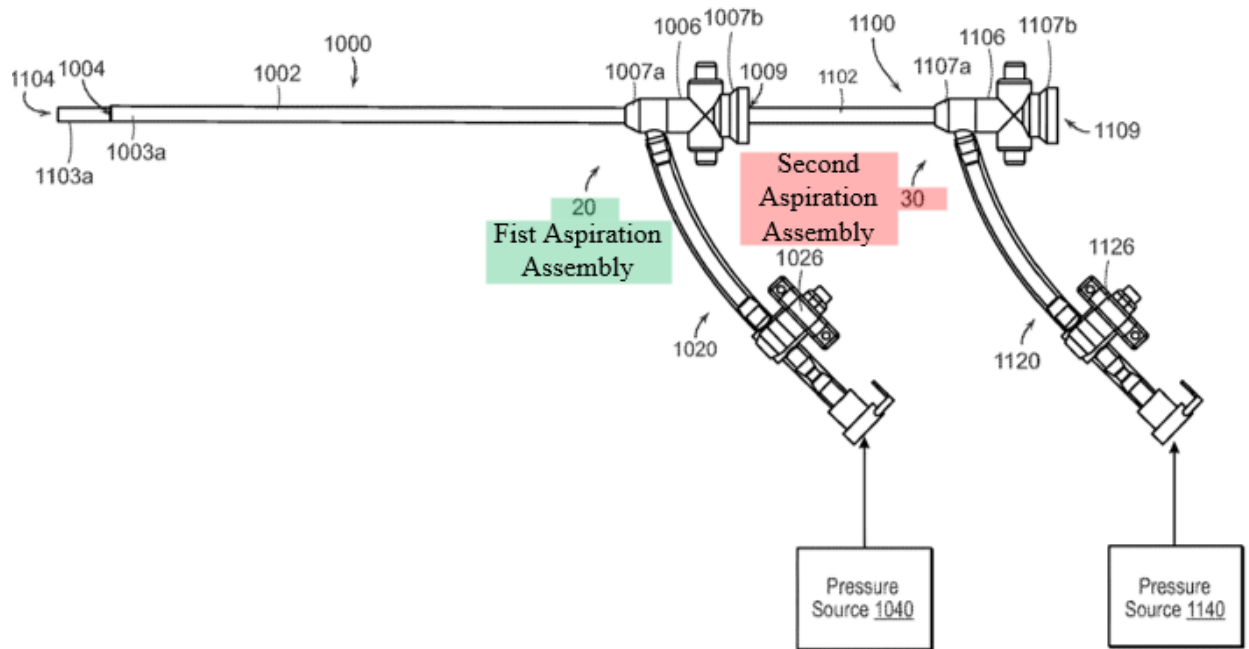

FIG. 11

The first clot aspiration assembly 20 includes a first catheter 1002 connected to a first pressure source 1040 via a first fluid control device 1026, and the second clot aspiration assembly 30 has a second catheter 1102 connected to a second pressure source 1140 via a second fluid control device 1126:

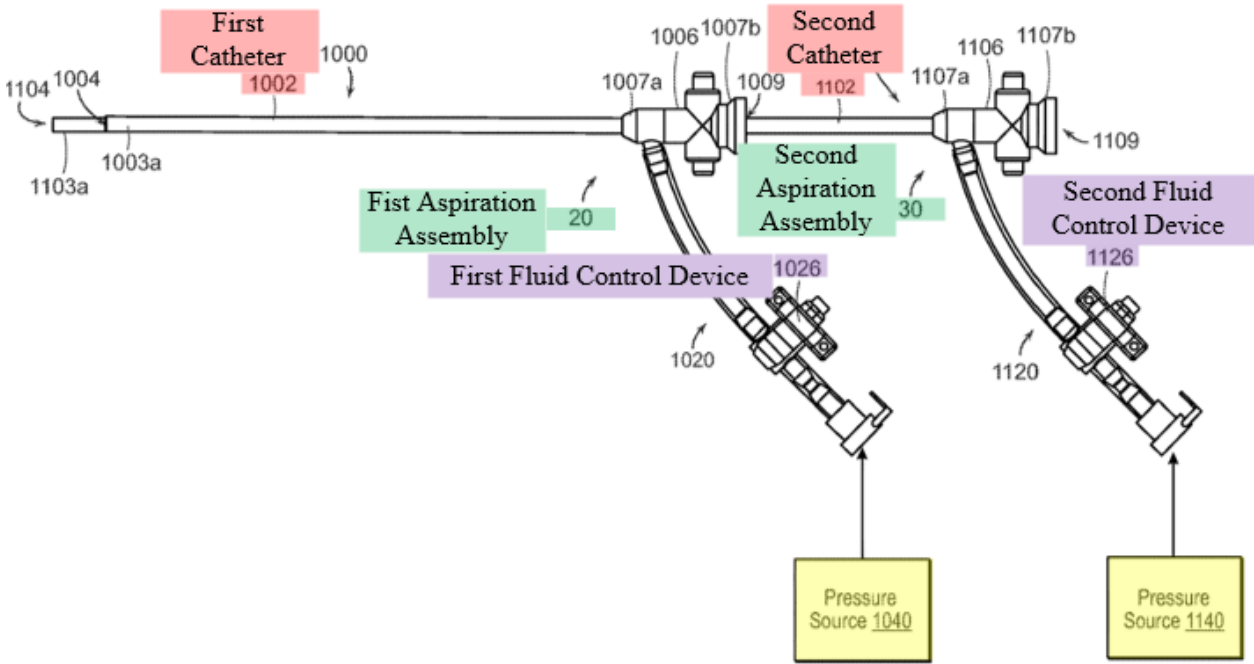

FIG. 11

41. As shown in Figure 13A of the '910 Patent, a distal portion 1103a of the second catheter 1102 is advanced (i.e., telescoped) through the first catheter 1002 and intravascularly positioned proximate to a PE:

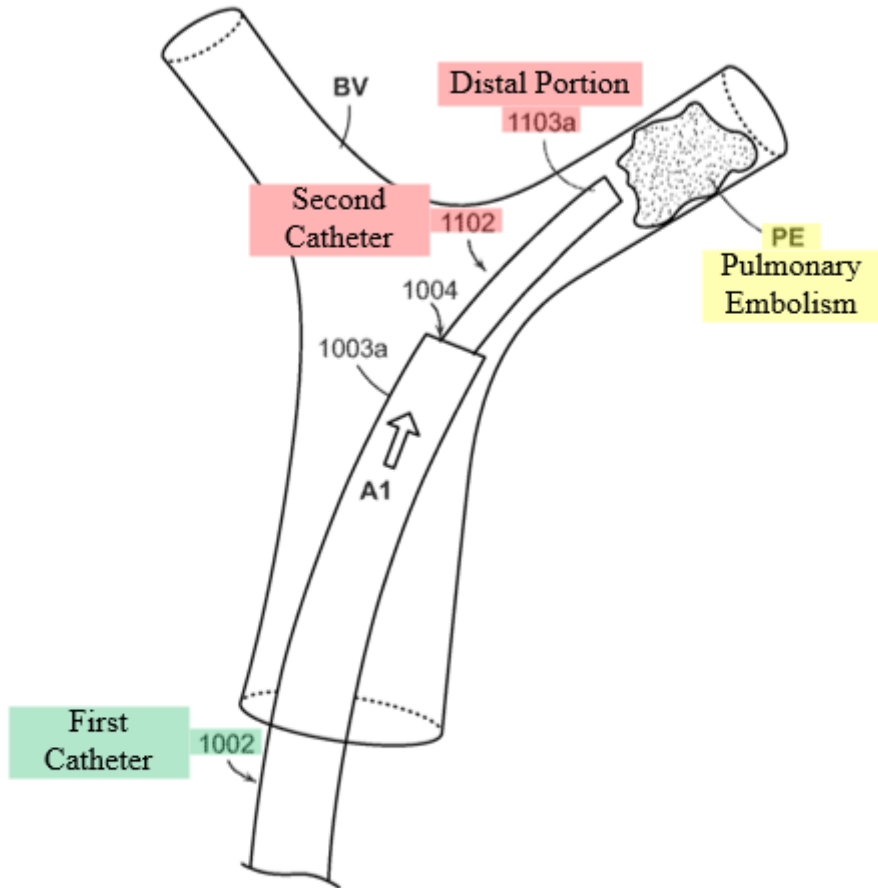

FIG. 13A

The second pressure source 1140 is then activated to generate vacuum pressure while the second fluid control device 1126 is closed to “build-up or pre-charge a vacuum for subsequent application to the second catheter 1102.” EX1001, 23:21–29. That built-up vacuum pressure is then applied to the second catheter 1102 by opening the second fluid control device 1126 to aspirate at least a portion of the PE into and through the second catheter 1102 as shown in Figure 13B:

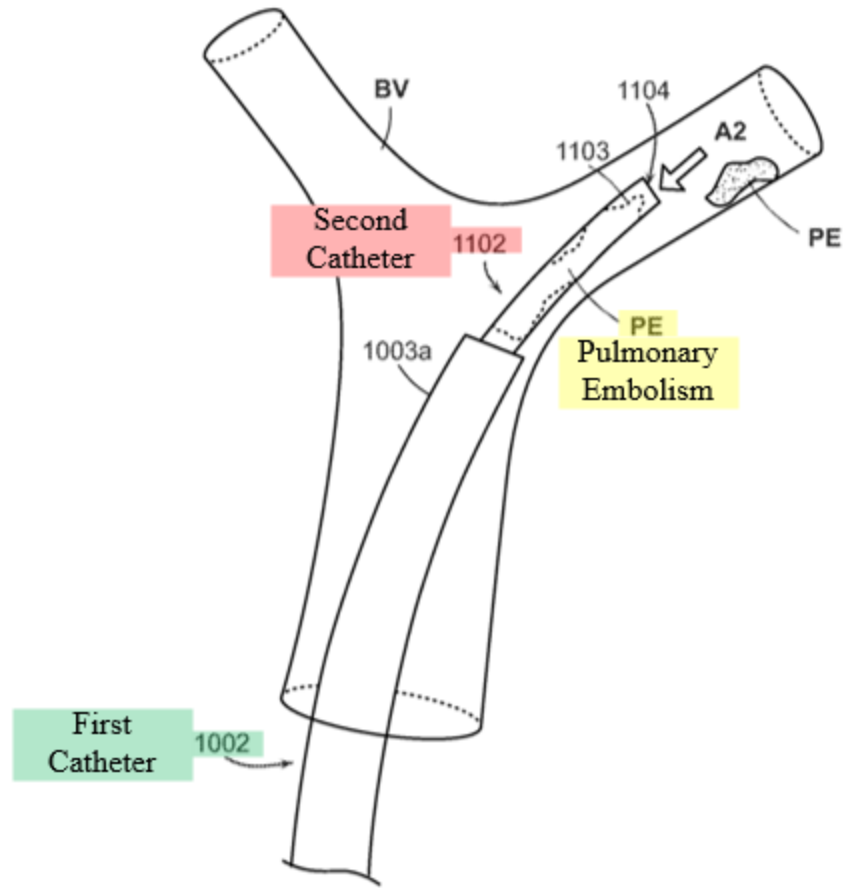

FIG. 13B

Id. at 23:30-40. The '910 Patent explains that “pre-charging or storing the vacuum before applying the vacuum to the lumen 1104 of the second catheter 1102 is expected to generate greater suction forces (and corresponding fluid flow velocities) at and/or near the distal portion 1103a of the second catheter 1102 compared to simply activating the second pressure source 1140 while it is fluidly connected to the second catheter 1102.” *Id.* at 23:40-47.

42. The '910 Patent explains that the first pressure source and the second pressure source can either be a pump, or alternatively a different pressure source such as a syringe: “the pressure source can be a pump (e.g., an electric pump coupled to a vacuum chamber) while, in other embodiments, the pressure source can include one or more syringes that can be actuated or otherwise activated by a user ... to generate and store a vacuum therein.” *Id.* at 7:36-41. Thus, in different embodiments of the '910 Patent, the pressure sources are either a pump or a syringe.

B. Prosecution History

43. I have reviewed the prosecution history of the '910 Patent, including the only Office Action mailed November 5, 2023 (EX1002, pgs.373-380), the Amendments and Response to the Office Action filed February 6, 2025 (*Id.* at pgs.141-149), and the Notice of Allowance mailed July 18, 2023 (*Id.* at pgs.43-50). In the Office action, the Examiner allowed independent claims 1 and 11 (which became Claims 1 and 11 of the '910 Patent challenged here), but relied on the same primary reference relied on by Petitioner here—Garrison—to reject original independent claim 18 as anticipated under 35 U.S.C. § 102(a)(1). *Id.* at pg.375. The Examiner found the claims to be allowable over Garrison because Garrison fails to disclose “a second catheter advanceable through the first catheter; a second pressure source; and a fluid control device

between the second catheter and the second pressure source’.” *Id.* at pg.377. I agree as I explain below.

44. In response to the Office action, Inari canceled independent claim 18 and amended allowable independent claims 1 and 11 (which, again, became Claims 1 and 11 of the '910 Patent challenged here) to narrow those allowed claims to clot treatment systems “for treating clot material comprising a pulmonary embolism” and wherein the second (e.g., inner and thus smaller) catheter “has a size of 16 French or greater” and “is shaped to be intravascularly advanced through the vasculature of the patient such that the distal portion of the second catheter is positioned proximate to the pulmonary embolism.” *Id.* at pgs.142-145. That is, Inari specifically narrowed the claims to treating PE with large catheters (16 French and greater). In the response, Inari explained that:

[I]ndependent claims 1 and 11, as amended, are further patentable over Garrison for at least the reasons discussed during the January 25th videoconference interview with the Examiner and his supervisor in related U.S. Patent Application No. 18/329,450, and specifically the Examiner’s comments in the Applicant-Initiated Interview Summary mailed January 31, 2024 that “Attorney and Examiner agree that incorporating more structural claim language, i.e. diameter of the catheter, would make the claim 1 allowable over the prior art Garrison.”

Id. at pgs.147-148. Accordingly, it is apparent to me that Inari substantively discussed the disclosure of Garrison in an interview with the same Examiner in a related application claiming similar subject matter, and further narrowed the allowed claims by amendment based on discussions with the Examiner about Garrison to treating PE with large catheters.

45. Following Inari's amendment and response to the Office action, the Examiner agreed and further explained why the claims are patentable over Garrison in the Notice of Allowance:

Claims 1 and 11 are allowable for reciting, inter alia, "a clot treatment system for treating clot material comprising a pulmonary embolism in the vasculature of a patient" and "wherein the second catheter has a size of 16 French or greater".

Garrison (US 20150173782 A1) ... fails to teach a ["clot treatment system for treating clot material comprising a pulmonary embolism in the vasculature of a patient" and "wherein the second catheter has a size of 16 French or greater". The clot treatment device of Garrison is configured for a neurovascular application and not for larger vasculature such as pulmonary embolism. It would be unreasonable to modify the clot treatment device of Garrison to be used for pulmonary embolisms. There is no prior art that teaches all of the limitations. Therefore, claims 1 and 11 are allowable.

Id. at pg.49.

46. As I explain below, I agree with the Examiner that a person of ordinary skill in the art (a “POSITA”) would not have modified Garrison to treat PE, including because a POSITA would not redesign Garrison to increase the size of its catheters because it would make the catheter unsuitable for the cerebrovascular treatments that are Garrison’s goal.

C. Person of Ordinary Skill in the Art

47. My opinion on the level of ordinary skill in the art is based upon my personal knowledge and experience as well as my consideration of such things as the education and experience level of persons of skill working in the field. I disagree that a POSITA would have had only “an undergraduate degree in mechanical engineering or a related engineering discipline and 2-4 years of catheter design experience and, where necessary, would have consulted with a physician regarding the methods of treatment.” Petition, pg.18. Rather, a POSITA would have been (1) a person with a Bachelor of Science degree in engineering or an equivalent field, with two to four years of academic or industry experience in the mechanical thrombectomy industry or comparable industry experience who would, where necessary or desired, work or consult with others including a physician to develop thrombectomy devices (including for smaller arteries); or (2) an interventional radiologist or pulmonologist with at least three years of experience developing and/or using medical

devices in thrombectomy procedures (including for smaller arteries), and who would, where necessary, work or consult with others including an engineer to develop such a medical device. A person with less education but more relevant practical experience, or more relevant education but less practical experience, may also meet this standard. I was also at least a person of ordinary skill in the art as of the priority date of the '910 Patent according to both standards, and my opinions herein are the same under either standard.

D. Claim Construction

48. Petitioner proposes a construction only for the term “filament” recited in dependent Claim 7. Petition, pg.19. Because my analysis here focuses on the patentability of independent Claims 1 and 11, and not on Claim 7 specifically, I have not provided a construction of “filament” at this time in this matter, but I have in other matters.

VI. REFERENCES

A. Garrison

49. Garrison is directed to systems for treating acute ischemic stroke caused by small cerebral clots in the cerebral arterial vasculature rather than, for example, treating large clots (e.g., PE) in the venous vasculature that is much larger in diameter than the cerebral vessels, as described in the '910 Patent. EX1006, ¶[0002]. For example, Figure 33 (reproduced below) of Garrison shows an arterial access device 2010 that provides access to the common carotid artery

(CCA), and a smaller in diameter catheter 2030 inserted through the arterial access device 2010 such that a distal tip of the catheter 2030 is positioned in the middle cerebral artery (MCA). EX1006, ¶[0131]. The arterial access device 2010 is connected to a flow line 2025, which is connected in series to a filter 3418, a check valve 3419, a source of aspiration 3125 (a peristaltic pump), and a receptacle 3100, respectively. *Id.* The catheter 2030 is similarly connected to a flow line 2045, a filter 3418, a check valve 3419, a source of aspiration 3425 (a peristaltic pump), and a receptacle 3105. *Id.*

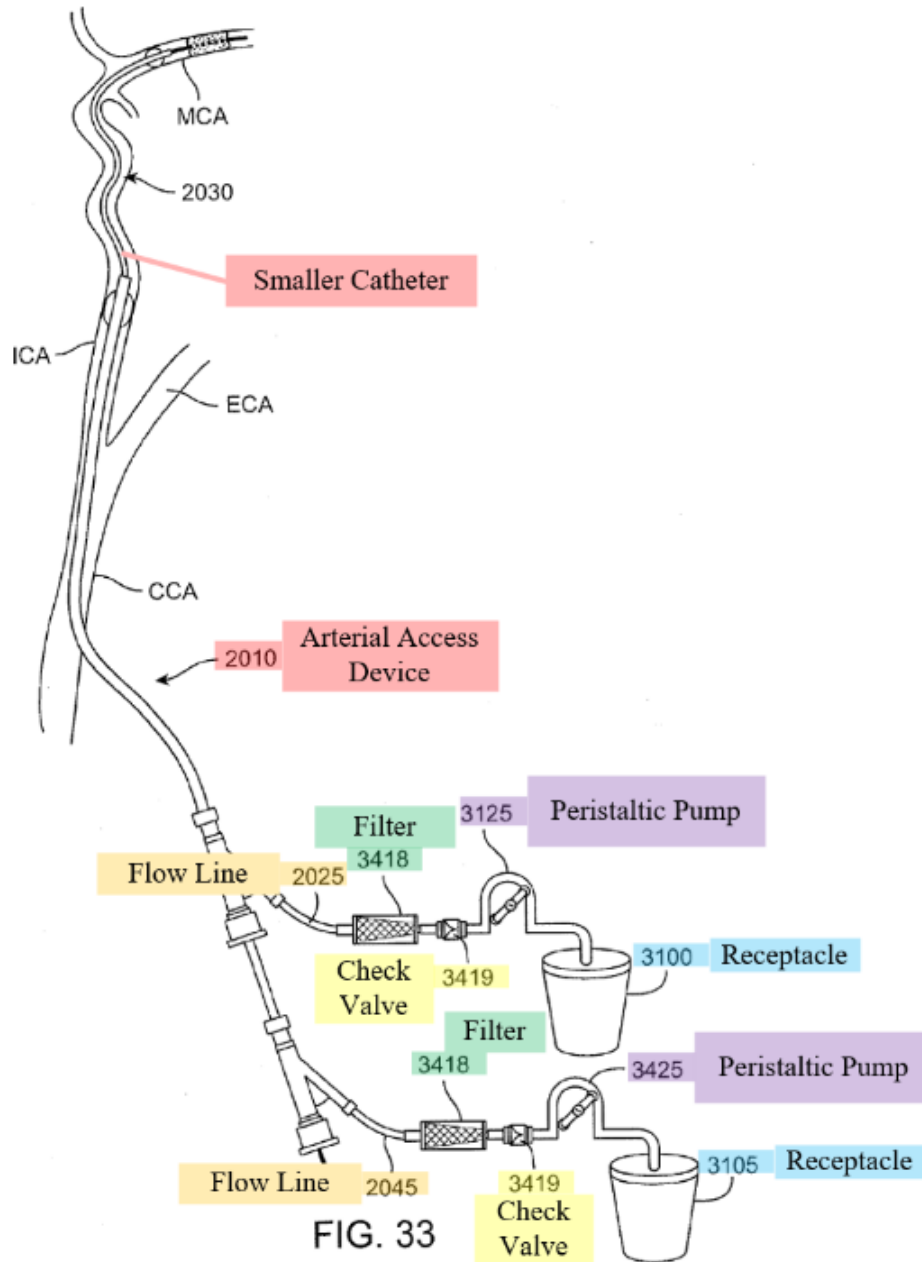

As can be seen above, Figure 33 does not include any valve in either flow path between the peristaltic pumps and connected catheter would allow for building up and then releasing vacuum pressure.

50. Figure 34 of Garrison (reproduced below) shows a similar system in which “both the arterial access device 2010 and catheter 2030 are connected to the

same aspiration source 3430 via flow lines 2025 and 2045, respectively.” *Id.* at ¶[0132]. A “valve 3325 controls which device is connected to the aspiration source 3430 [t]he valve may enable one device, the other device, both devices, or neither device to be connected to the aspiration source at any given time.” *Id.* Downstream of the aspiration source 3430 is a receptacle for receiving and holding aspirated blood.

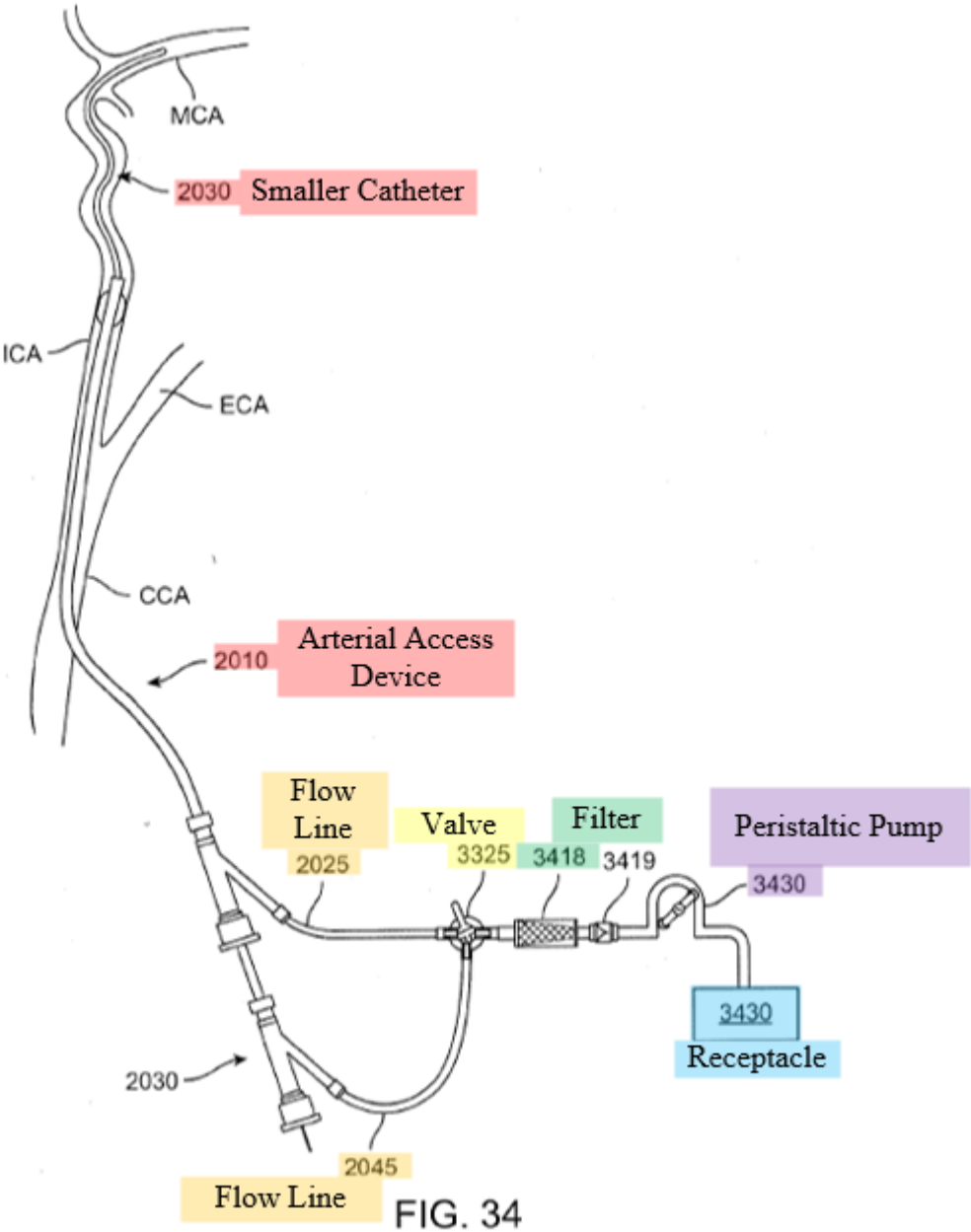

51. A POSITA would recognize that the aspiration sources 3125/3425 in Figures 33 and 34 are peristaltic pumps based on their depiction including compressible tubing and a rotatable shaft connected to a rotor that carries multiple

rollers for compressing the tubing as I have labeled in the enlargement to Figure 34 below:

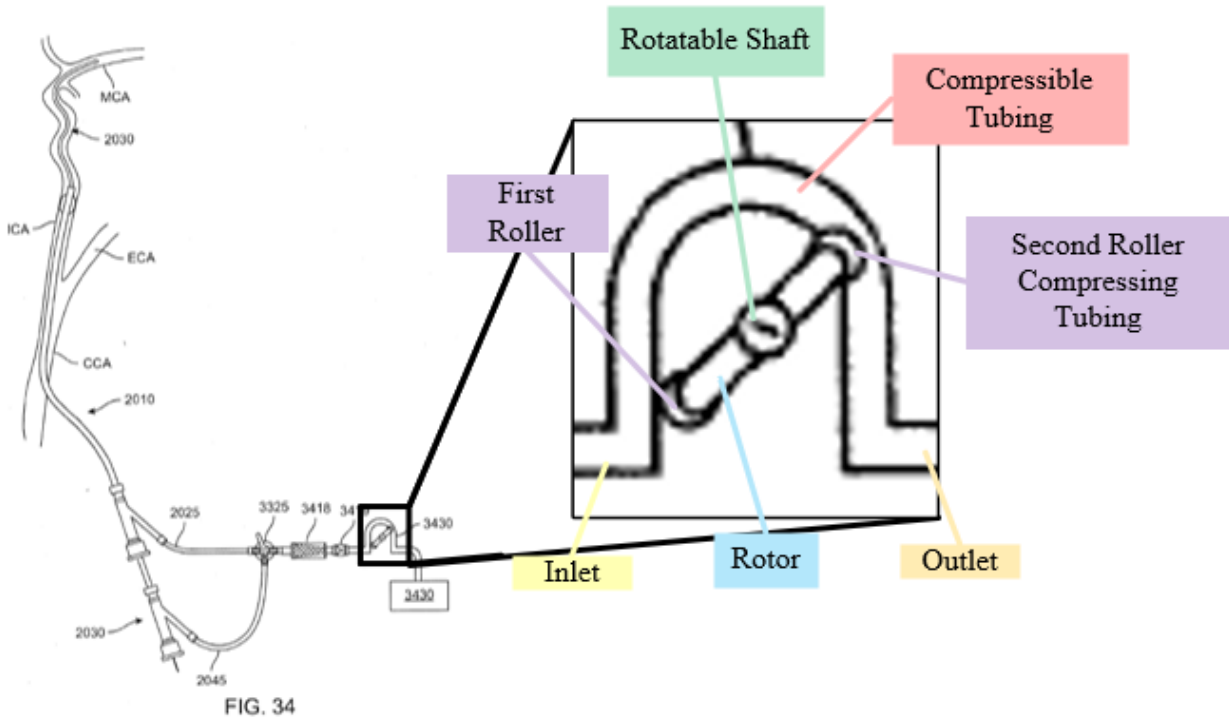

A POSITA would understand that the peristaltic pump is a positive displacement pump that operates by rotating the shaft to rotate the rotor such that the rollers compress and seal the tubing during passes along the length of the tubing, alternating the compression and relaxation of the tubing, and drawing content in and propelling product away from the pump to: (1) generate negative pressure to draw fluid through one or both of the flow lines 2025/2045 through the inlet of the pump, (2) transport the fluid through the pump, and (3) expel the fluid through the outlet of the pump for delivery to the receptacle 3430. A POSITA would further understand that peristaltic pumps

advantageously contain blood entirely within the tubing as it moves through the peristaltic pump such that the blood does not directly contact any of the pump parts. This permits the pump to be reused in subsequent medical procedures because the tubing (which is the only portion contaminated by blood) can be easily removed from the pump and discarded after the procedure. For example, the blood does not contact an impeller or other movable part as in other types of pumps, such as a centrifugal pump. The pump can then be reused with new tubing.

52. Garrison discloses that “[t]he receptacle 3100 and source of aspiration 3125 may be separate or may be combined into a single device such as a syringe.” EX1006, ¶[0131]. A syringe is the one example Garrison provides of a combined receptacle and source of aspiration. Garrison distinguishes between such embodiments and an aspiration pump as distinct alternatives by disclosing that the “active source of aspiration may be an aspiration pump, a regular or locking syringe, a hand-held aspirator, hospital suction, **or** the like.” EX1006, ¶[0134] (my emphasis added); *see also id.* at ¶[0071] (“aspiration source such as a pump or a syringe”).
53. Garrison discloses “one embodiment” of a syringe-based system in which “a locking syringe (for example a VacLok Syringe) is attached to the flow controller and the plunger is pulled back into a locked position by the user while

the connection to the flow line is closed prior to the thrombectomy step of the procedure.” *Id.* at ¶[0134]. Accordingly, when the syringe is used in that one embodiment, the syringe is attached directly to the flow controller (e.g., valve) to “enable the maximum level of aspiration” by reducing any dead volume between the syringe and the valve. *Id.* Then, “[d]uring the procedure when the tip of the aspiration device ... is near or at the face of the occlusion, the user may open the connection to the aspiration syringe ... [t]his would enable the maximum level of aspiration in a rapid fashion with one user.” *Id.* In this embodiment, the locking syringe is actuated with the connection to the flow line closed such that vacuum is generated in the syringe.

54. With reference to the embodiments shown in Figures 33 and 34 of Garrison and the different locking syringe embodiment disclosed (but not illustrated) in paragraph [0134], Garrison goes on to explain that those embodiments are disadvantageous:

One disadvantage of current sources of aspiration is that the aspirated blood is received into an external reservoir or syringe. This blood is generally discarded at the end of the procedure, and as such represents blood loss from the patient. In addition, pumps such as centrifugal or peristaltic pumps are known to cause damage to blood cells. Although it is possible to return blood from the external reservoir to the patient, the blood has been exposed to air or has been static for a period of time, and there is risk of

thrombus formation or damage to the blood cells. Usually, aspirated blood is not returned to the patient to avoid risk of thromboembolism.

Id. at ¶[0135]. That is, when blood is pumped to a downstream receptacle as shown in Figures 33 and 34, or directly collected in a syringe, such as the one described in paragraph [0134], the blood is not suitable for reinfusion to the patient because the blood remains static and/or is exposed to air such that it can clot or blood cells can otherwise be damaged.

55. To address that disadvantage, Garrison discloses a different system in Figure 36 “which is configured not to harm blood cells and which may be configured to return blood to the central venous system in real time during the procedure, so there is no reservoir in which the blood remains static.” *Id.* at ¶[0136]. Figure 36 illustrates a pump device 3250 connected to either or both of the flow lines of the arterial access device or smaller inner catheter and includes a housing that encloses a chamber that is not fluidically connected to the catheter:

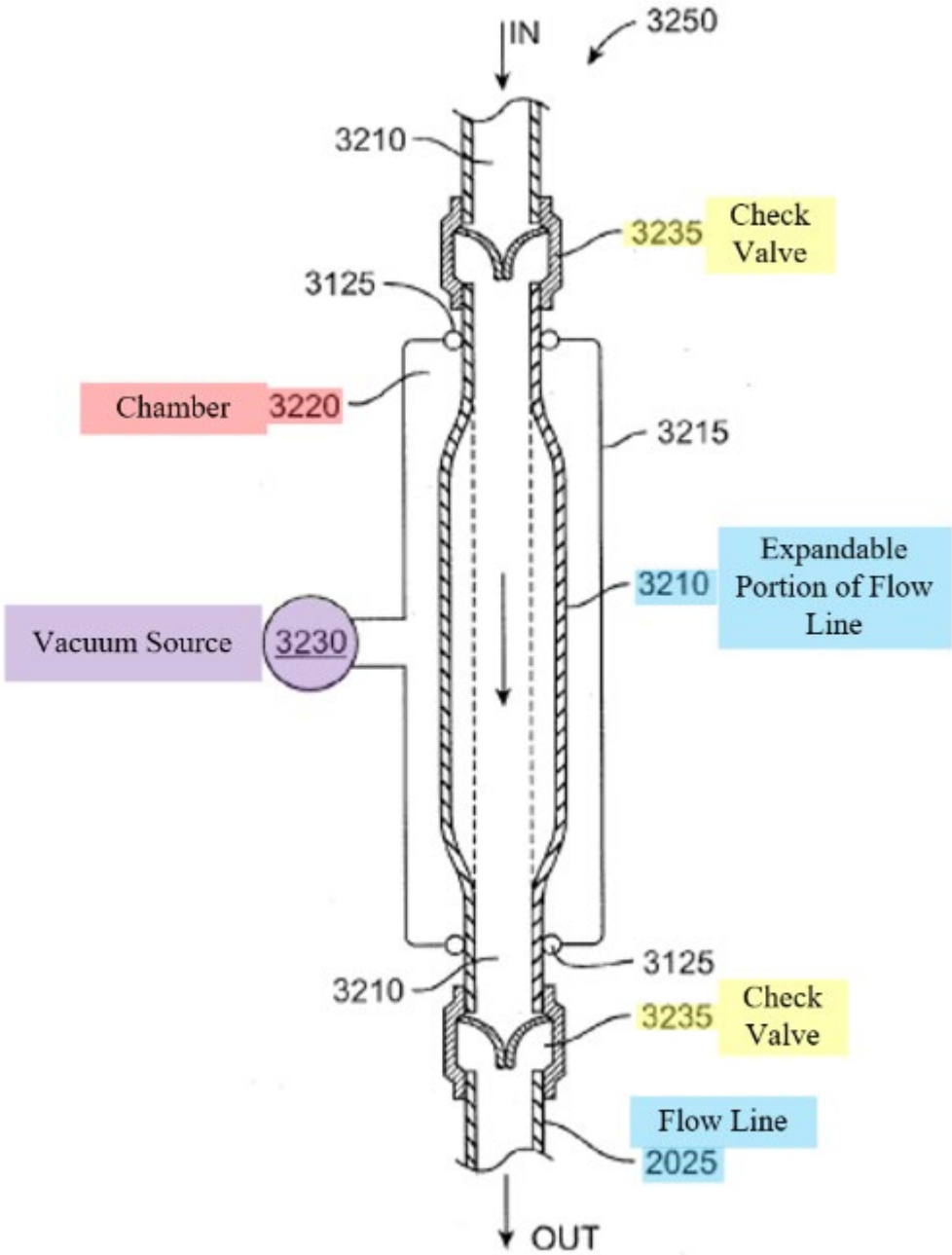

FIG. 36

EX1006, ¶[0136].

- 56. The chamber 3220 is connected to a vacuum source 3230, which is configured to generate (1) negative pressure in the chamber 3220 to cause the expandable

portion 3210 of the flow line 2025 to expand to draw blood into the expandable portion 3210 through the upstream one-way check valve 3235 and (2) subsequent normalized pressure in the chamber 3220 to permit the expandable portion 3210 to contract to expel blood from the expandable portion 3210 through the downstream one-way check valve 3235. *Id.* at ¶¶[0136]-[0137]. So, like a peristaltic pump or a centrifugal pump, the pump device 3250 operates to pull blood through an inlet and subsequently expel blood through an outlet. The pump device is “configured to return blood to the central venous system in real time during the procedure, so there is no reservoir in which the blood remains static” by operating the vacuum source so as to oscillate the expandable portion between the expanded and retracted states to, together with the one-way check valves, thereby drive fluid through the flow line. *Id.* Thus, a POSITA would understand that the pump device 3250 is designed to continuously operate to shuttle blood into the inlet and out of the outlet without delay. The pump in Figure 36 is another type of positive displacement pump like a peristaltic pump, but that operates without rollers that compress tubing.

B. Laub

57. Laub discloses a “system for removing thrombi and other unwanted material from the body of a patient, particularly from the patient’s vasculature” and,

more particularly, a system “to remove clots from patients suffering from or at risk of pulmonary embolisms.” EX1012, ¶[0005]. The embodiment of Laub relied on by Petitioner is shown in Figure 1A (reproduced below) and includes a single aspiration catheter 200 in fluid communication with a filter 300, a pump 400, and a return catheter 500:

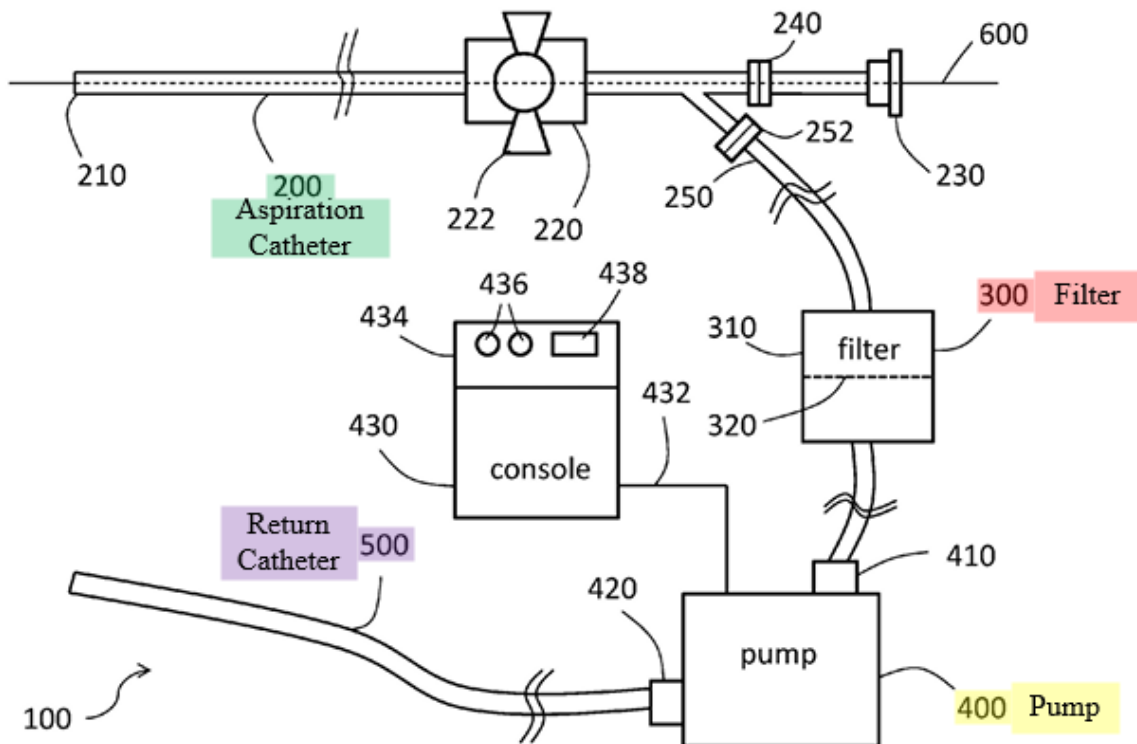

FIG. 1A

Id. at ¶[0024]. Because there is no valve in the flow path, the pump 400 operates to continuously suction blood and thrombi through the aspiration catheter 200 and the filter 300 and then drive the filtered blood through the return catheter 500 back into the patient. *Id.* In other words, it does not generate a stored vacuum pressure. Accordingly, Laub discloses that “[i]n preferred

embodiments, pump 400 is a centrifugal pump” while “[i]n other embodiments, pump 400 may be a rotary pump, peristaltic pump, roller pump, or other form of pump known in the art.” *Id.* at ¶[0041].

58. Laub discloses that the aspiration catheter 200 can have a wide range of sizes, but emphasizes that “[i]n certain preferred embodiments, aspiration catheter has a French size of equal to or greater than 10 Fr to allow for aspiration of large thrombi and/or other solid materials from the patient.” *Id.* at ¶[0028]. A POSITA would understand that a PE is a large clot. Laub also discloses a wide range of flow rates including flow rates up to 6 liters per minute. *Id.* at ¶¶[0043]-[0044].
59. Because of those large flow rates enabled by a large catheter, Laub correctly recognizes the need for blood reinfusion: “Without returning the blood back to the patient, such high flow rates could quickly result in exsanguination of the patient.” *Id.* at ¶[0045]. That is, the patient will bleed out and die or go into shock if the blood is not returned. “By returning the aspirated blood back to the patient, embodiments of the present system 100 allows for aspiration while minimizing the blood loss of the patient.” *Id.* Laub also discloses that “reinfusing the patient’s blood continuously during aspiration allows for greater suction pressure and/or flow rates (e.g., 2-4 L/min) which can assist in dislodging and removing larger clots and/or tumors than would otherwise be

possible.” *Id.* Accordingly, a POSITA would understand that Laub’s system is intended to be operated to continuously aspirate and return blood at a high flow rate so that large clots, such as PE, can be removed. Laub discloses that its system would endanger the patient if blood were not returned.

C. Aklog

60. A POSITA would understand Aklog’s system to be largely the same as Laub’s, and Petitioner recognizes that stating that “[s]imilarly, Aklog discloses systems and methods for removing clot material from ‘the pulmonary circulation (e.g., pulmonary arteries), systemic venous circulation (e.g., vena cavae, pelvic veins, leg veins, neck and arm veins) or arterial circulation (e.g., aorta or its large and medium branches).’” Petition, pgs.24-25 (emphasis added). Indeed, like Laub, the embodiments of Aklog relied on in the Petition and shown in Figures 1, 6, and 7 of Aklog (Figure 1 reproduced below) include a single aspiration catheter (cannula) 10 in fluid communication with a filter device 14, a pump 15, and a reinfusion catheter (cannula) 16:

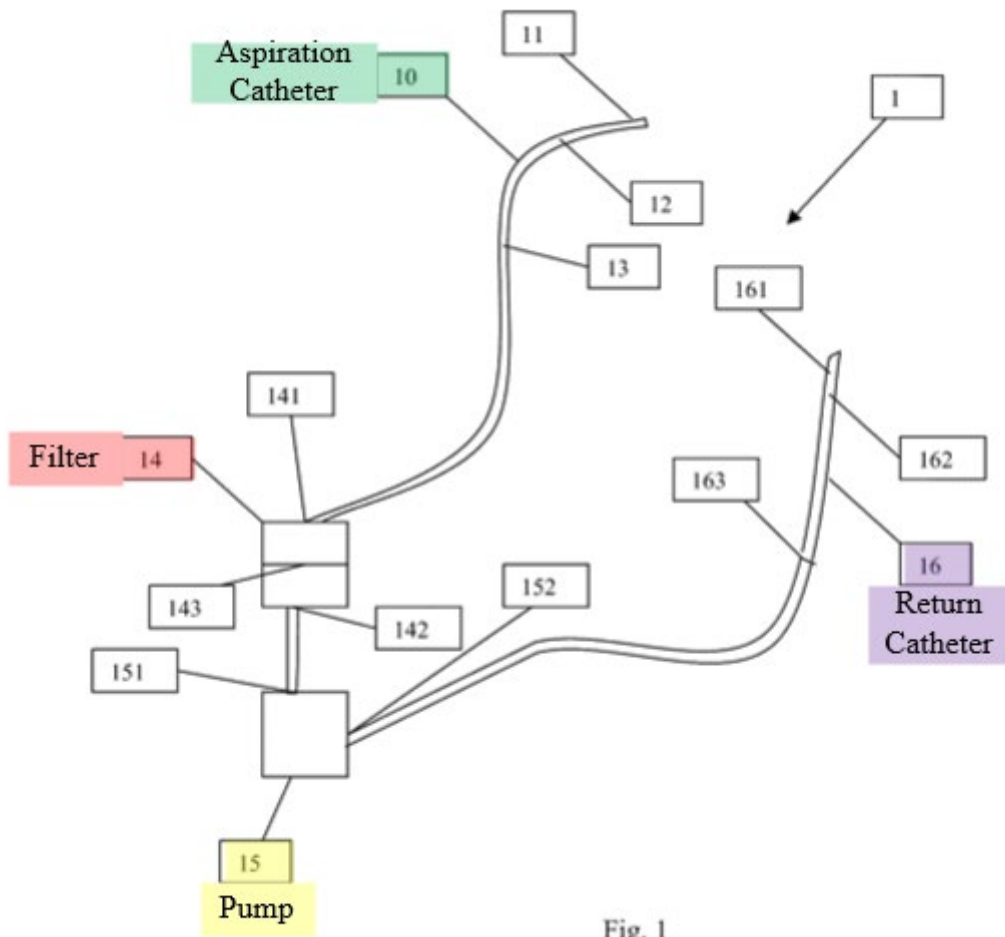

Fig. 1

EX1005, 11:24-12:34. As in Laub, because there is no valve in the flow path, the pump 15 operates to continuously suction blood and thrombi through the aspiration catheter 10 and the filter device 14 and then drive the filtered blood through the reinfusion catheter 16 into the patient. *Id.* Aklog also does not disclose any other mechanism for building up a stored vacuum pressure either, employing a continuous pump.

61. The aspiration catheter 10 “may be of any sufficient size, so long as it can be accommodated within a predetermined vessel, such as a medium to large size

blood vessel.” *Id.* at 11:12-15. For example, “the suction cannula 10 may be designed to remove at least 10 cm³ of undesirable material substantially en bloc.” *Id.* at 11:18-20. A POSITA would understand that a clot of 10 cm³ is much larger than neurovascular clots and more akin to the size of a PE. And, “[b]ecause the normal rate of blood flow through the heart and large blood vessels can be significant, suction cannula 11 and reinfusion cannula 16, when used around the heart and other large vessels, may displace a relatively large volume of fluid into and out of the patient's circulatory system.” *Id.* at 19:57-62.

62. Given the large clots that Aklog is designed to treat, Aklog correctly recognizes that “[i]f the catheter is enlarged to accommodate the larger structure and material, such a catheter may aspirate an unacceptable volume of blood, resulting in excessive fluid loss and/or shock in the patient.” *Id.* at 7:23-26. That is, the patient will be harmed due to excessive blood removal if the blood is not returned. To address this, Aklog’s system “simultaneously reinfuse[s] aspirated (i.e., removed) and filtered fluid, such as blood, back into the patient on a substantially continuous basis to minimize any occurrences of fluid loss and/or shock.” *Id.* at 5:19-23. Aklog further teaches that the “suction and reinfusion of blood can occur, in an embodiment, continuously for a desired duration to minimize fluid loss in the patient.” EX1005, 5:20-23. Accordingly,

like Laub, a POSITA would understand that Aklog's system is intended to be operated to continuously aspirate and return blood so that large clots can be removed. Aklog discloses that its system would endanger the patient if blood were not returned.

VII. GROUNDS 1-3: THE COMBINATION OF GARRISON AND LAUB AND/OR AKLOG DOES NOT RENDER OBVIOUS ANY OF CLAIMS 1-6, 8, 11-15, OR 18-20

63. Petitioner and its expert, Mr. Thornton, allege that Garrison in combination with Laub (ground 1) or Aklog (ground 2) or Laub and Aklog (ground 3) renders obvious Claims 1-6, 8, 11-15, and 18-20 of the '910 Patent. I disagree for the reasons I discuss in further detail in this section.
64. As I explained above, I understand that for a patent claim to be rendered obvious, the differences between the claimed invention and the prior art must be such that the claimed invention as a whole would have been obvious before the effective filing date of the claimed invention to a person having ordinary skill in the art to which the claimed invention pertains, the claimed invention is obvious. Even if all limitations of a claimed invention are disclosed by the prior art combination, Petitioner must demonstrate an apparent reason to combine the known elements in the fashion of the patent claim at issue and that a person of ordinary skill in the art would have reasonable expectation of success in pursuing that combination. A prior art reference teaches away from a

modification of a prior art reference when a person of ordinary skill in the art would be discouraged from following the path set out in the reference, or would be led in a direction divergent from the path followed by and claimed in the patent.

65. But Petitioner picks and chooses features of various embodiments to manufacture a purported system that Garrison does not disclose and that is contrary to Garrison's disclosure. Specifically, Petitioner relies on Garrison for disclosing all the features of independent Claims 1 and 11 except "for treating clot material comprising a pulmonary embolism" and wherein the second (e.g., inner telescoping) catheter "has a size of 16 French or greater" and "is shaped to be intravascularly advanced through the vasculature of the patient such that the distal portion of the second catheter is positioned proximate to the pulmonary embolism." That is, Petitioner asserts that Garrison discloses all the features of Claims 1 and 11 aside from treating PE with large catheters having a size of 16 French or greater.
66. But, Garrison does not disclose or suggest the "first fluid control device" or the second "fluid control device" recited in independent Claim 1, or the "fluid control device" recited in independent Claim 11, let alone the buildup and subsequent release of stored vacuum pressure recited in Claims 1 and 11 (i.e., "[generating] vacuum pressure while the ... fluid control device is in the first

position” and “wherein, upon movement of the ... fluid control device from the first position to the second position, the vacuum pressure is applied to the ... catheter to generate suction at the distal portion of the ... catheter”). Because Garrison does not disclose such fluid control devices, Petitioner provides a demonstrative illustration of Figure 33 that is not found in Garrison that adds two of the single valve 3325 shown in Figure 34 (a 3-way or 4-way stopcock) into the system of Figure 33. Petition, pg.51; *see also id.* at pg.72 (relying on the same demonstrative regarding independent Claim 11). But, a POSITA would not have included those valves in the system of Figure 33 and operated Garrison’s pumps in Figure 33 to build up vacuum pressure while the valves were closed because that would starve Garrison’s pumps (e.g., peristaltic, centrifugal, or positive displacement pumps) of fluid likely damaging the bloods and any blood in the system.

67. And, while Garrison discloses the buildup and release of vacuum pressure, that is only for one embodiment using a syringe connected directly to a flow controller described in paragraph [0134] to “enable the maximum level of aspiration.” That embodiment is different than the embodiment shown in Figure 33 relied on by Petitioner because it utilizes a syringe rather than a peristaltic or other pump, and the syringe is connected directly to a flow controller rather than via a filter and a check valve like the peristaltic pumps shown in Figure

33. A POSITA would not have used a syringe in place of the pumps 3125/3425 in Petitioner's modified Figure 33 because the intervening filters, check valves 3419, and associated tubing would provide a dead space that would act to lessen aspiration rather than "enable the maximum level of aspiration."
68. Moreover, Petitioner's purported addition of valves to Figure 33 (1) would not provide any increased control or function different than simply operating Garrison's peristaltic pumps separately, (2) would provide dangerous flow paths for sucking air into the system through the unconnected port of the 3-way or 4-way stopcock that could be reinfused into the patient to cause an air embolism, and (3) would not enable a "maximum level of aspiration" because unlike a syringe with a large fixed volume to store the vacuum pressure for aspiration, a peristaltic pump's aspiration level is controlled by its operational speed and is void of a large fixed volume to store the vacuum pressure.
69. A POSITA also would not have used Petitioner's modified system or any of the embodiments of Garrison relied on by Petitioner to treat PE—even if the catheter were "upsized"—because while Petitioner's references with larger catheters recognize the criticality of blood reintroduction to patient health and safety when treating PE, Garrison expressly discloses that the embodiments relied on by Petitioner are not suitable for blood reintroduction. EX1006,

¶[0135]. And, a POSITA would understand that operating Petitioner’s purported modified system in Figure 33 of Garrison with valves closed would further damage blood when the pumps in that embodiment run with the valves closed—starving the pumps of fluid.

70. Finally, a POSITA would not have upsized Garrison’s catheters to have a size of “16 French or greater” as recited in independent Claims 1 and 11 because such a modification would render Garrison’s system unsuitable for its intended purpose of treating cerebral clot, and more particularly, clot in the middle cerebral artery as shown in, for example, Figures 33 and 34 of Garrison. Put simply, when upsized as Petitioner suggests, Garrisons’ catheters would be too large to fit into the vessels they are intended to be positioned in.
71. Accordingly, for those reasons and the reasons set forth below, it is my opinion that independent Claims 1 and 11 are not rendered obvious by Garrison in combination with Laub and/or Aklog. Dependent Claims 2-6 and 8 depend from independent Claim 1, and dependent Claims 12-15 and 18-20 depend from independent Claim 11. Therefore, these claims are also not rendered obvious by Garrison in combination with Laub and/or Aklog because they incorporate all the features of their respective independent Claims 1 or 11.

A. A POSITA Would Not Have Been Motivated to Modify Garrison to Arrive at Petitioner’s Purported Arrangement Adding Two Valves to Figure 33 of Garrison

72. As I explain in §V.A. above, both independent Claims 1 and 11 require “pre-charged” aspiration in which vacuum is built up when a fluid control device is in a first position to disconnect a pressure source from a catheter, then subsequently moved to a second position that fluidly connects the pressure to the catheter such that the vacuum is applied to the catheter. To effectuate that buildup and release of vacuum pressure in both aspiration catheter assemblies Claim 1 recites two fluid control devices, a “first fluid control device” and a “second fluid control device.” Specifically, independent Claim 1 requires:

a first fluid control device between the first catheter and the first pressure source, wherein the first fluid control device is movable between (a) a first position in which the first pressure source is fluidly disconnected from the first catheter and (b) a second position in which the first pressure source is fluidly connected to the first catheter,

wherein the first pressure source is configured to generate vacuum pressure while the first fluid control device is in the first position, and

wherein, upon movement of the first fluid control device from the first position to the second position, the vacuum pressure is applied to the first catheter to generate suction at a distal portion of the first catheter; and

a second fluid control device between the second catheter and the second pressure source, wherein the second fluid control device is movable between (a) a first position in which the second pressure source is fluidly disconnected from the second catheter and (b) a second position in which the second pressure source is fluidly connected to the second catheter,

wherein the second pressure source is configured to generate vacuum pressure while the second fluid control device is in the first position, and

wherein, upon movement of the second fluid control device from the first position to the second position, the vacuum pressure is applied to the second catheter to generate suction at the distal portion of the second catheter to aspirate blood and at least a portion of the pulmonary embolism into the second catheter.

Independent Claim 11 similarly requires:

a fluid control device between the second catheter and the second pressure source, wherein the fluid control device is movable between (a) a first position in which the second pressure source is fluidly disconnected from the second catheter and (b) a second position in which the second pressure source is fluidly connected to the second catheter,

wherein the second pressure source is configured to generate vacuum pressure while the fluid control device is in the first position, and

wherein, upon movement of the fluid control device from the first position to the second position, the vacuum pressure is applied to the second catheter to generate suction at the distal portion of the second catheter to aspirate blood and at least a portion of the pulmonary embolism into the second catheter.

73. Petitioner points to the various embodiments shown in Figures 33 and 34 and described in paragraphs [0131]-[0135] of Garrison to allege that Garrison discloses those features of Claims 1 and 11. But Petitioner picks and chooses features of various embodiments to manufacture a purported system that Garrison does not disclose and that is contrary to Garrison's disclosure and contrary to how a POSITA would have configured and operated Garrison's systems. I understand, the Board initially saw no "flaw in Petitioner's alleged mixing and matching of embodiments of Garrison." Institution Decision, p.32. But, below I address the Board's initial reasoning and I add further context to my Opening Declaration and explain why a POSITA would not have mixed and matched those embodiments as Petitioner alleges to arrive at their purported modification. Namely, a POSITA would not have used the peristaltic or like pumps in Petitioner's modification to Figure 33 of Garrison to build

up vacuum pressure with a valve closed because that would damage those pumps and blood in that system. And, a POSITA would not have used Garrison's syringe from paragraph [0134] in those embodiments because it would not "enable the maximum level of aspiration" as alleged by Petitioner.

74. More specifically, Petitioner relies on Figure 33 of Garrison for allegedly disclosing the "first clot aspiration assembly" including a "first catheter" and a "first pressure source," and the "second clot aspiration assembly" including a "second catheter" a "second pressure source" as shown in their annotated Figures below:

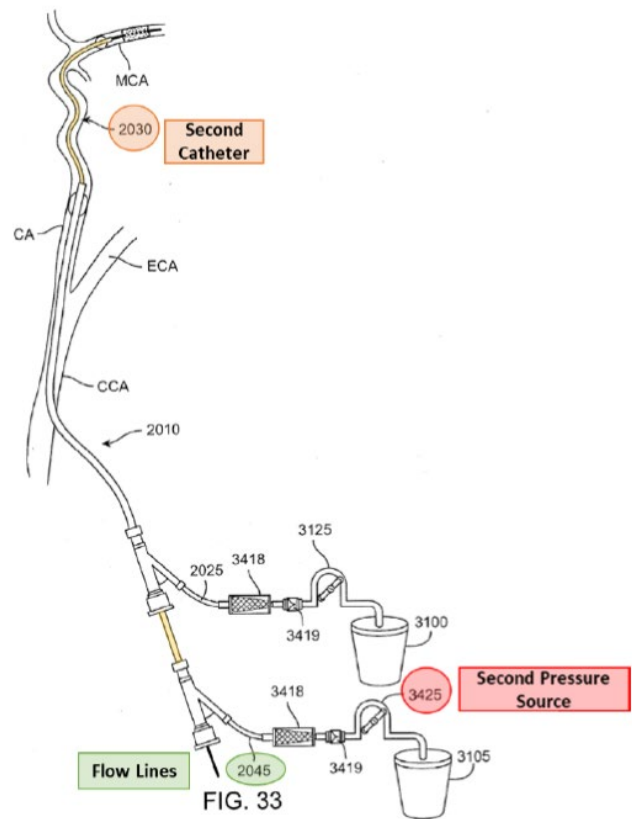
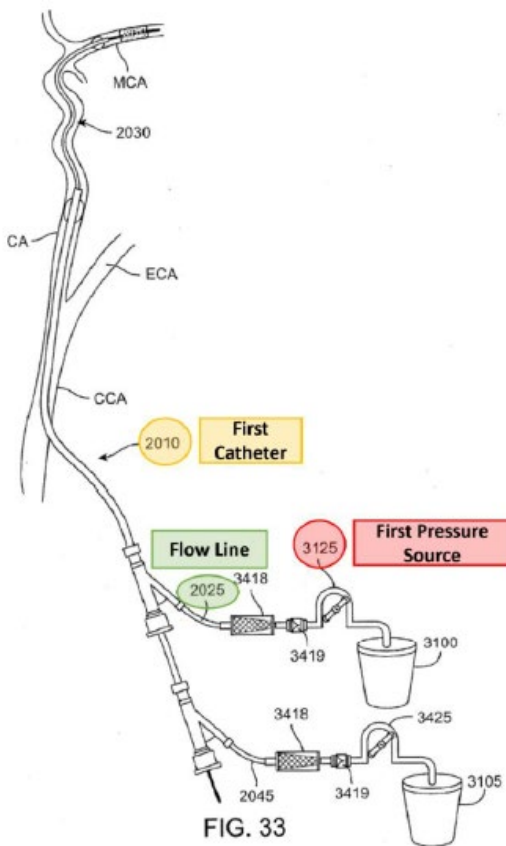

Petition, pgs.34-35 & 39-42. But, in the embodiment of Figure 33, the first pressure source 3125 is directly and always fluidly connected to the first catheter 2010 (via a check valve 3419 and a filter 3418) **without** any “first fluid control device” that “is movable between (a) a first position in which the first pressure source is fluidly disconnected from the first catheter and (b) a second position in which the first pressure source is fluidly connected to the first catheter,” as recited in independent Claim 1. EX1006, ¶[0131]. And, likewise, the second pressure source 3425 is directly and always fluidly connected to the second catheter 2030 (via a check valve 3419 and a filter 3418) **without** any “second fluid control device” that “is movable between (a) a first position in which the second pressure source is fluidly disconnected from the second catheter and (b) a second position in which the second pressure source is fluidly connected to the second catheter,” as recited in independent Claim 1 and similarly recited in independent Claim 11. *Id.* Accordingly, that Figure 33 cannot disclose any pressure source that is “configured to generate vacuum pressure” when a fluid control device is closed as recited in the Claims of the ’910 Patent—there is no fluid control device.

75. Because Figure 33 does not disclose any “fluid control device,” Petitioner next turns to Figure 34 of Garrison to find a valve as shown in their annotated Figure below:

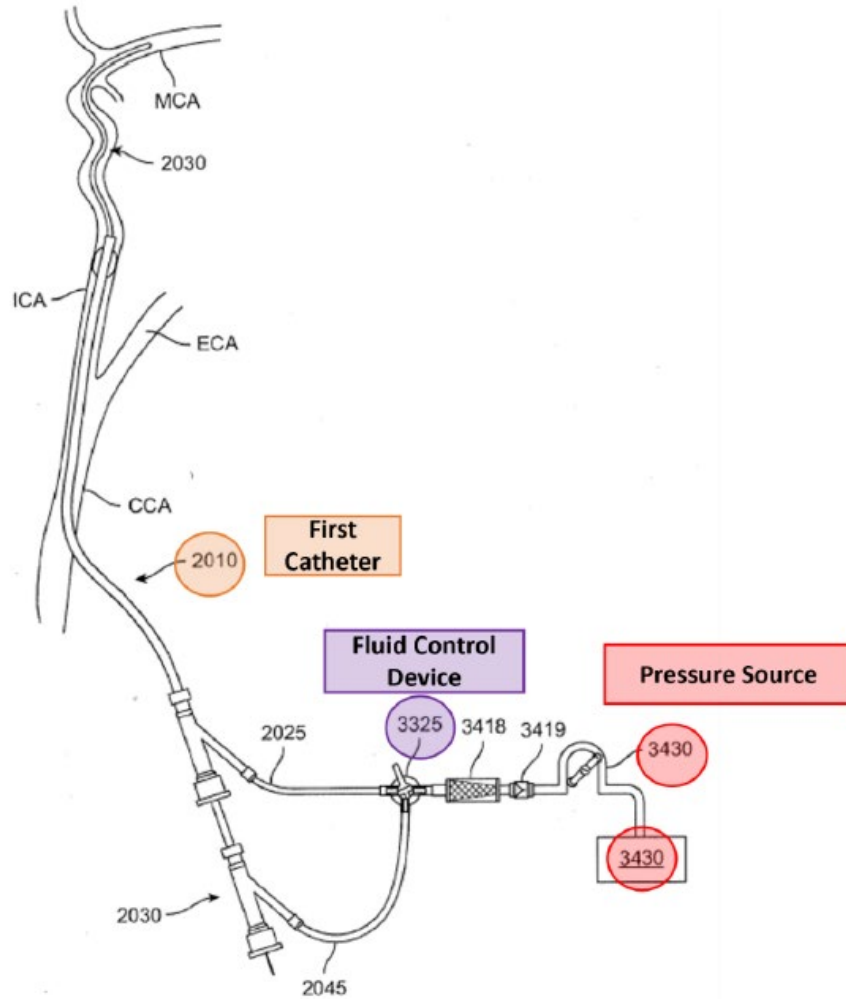
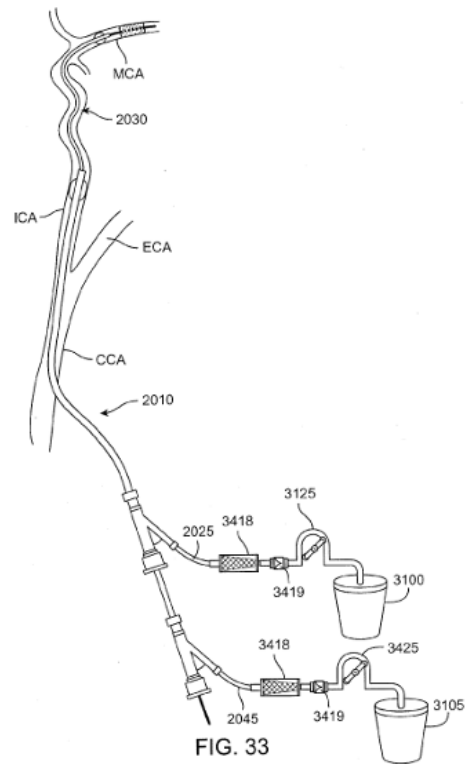
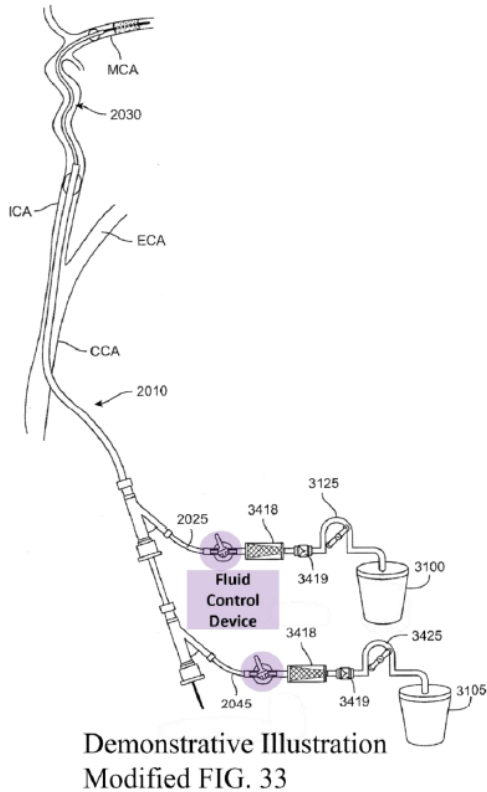

FIG. 34

Petition, pgs.35-37 & 49-54. In Figure 34, “both the arterial access device 2010 and the catheter 2030 are connected to the same aspiration source 3430” and the “valve 3325 controls which device is connected to the aspiration source 3430 ... [t]he valve may enable one device, the other device, both devices, or neither device to be connected to the aspiration source at any given time.” EX1006, ¶[0132]. That is, because the arterial access device 2010 and the catheter 2030 are connected to the same aspiration source 3430, the valve

3325 is used to control the connection of those catheters to the pressure source 3430. There is no disclosure in Garrison of using the valve 3325 to build up vacuum pressure when the valve is closed. And a POSITA would not have operated Garrison's system in such a manner because, as I explain below, doing so would cease fluid flow to the inlet of Garrison's pump and thereby starve the pump of fluid, potentially damaging the pump and harming blood in Garrison's system. Instead, a POSITA would understand the valve 3325 to simply enable selection of the appropriate catheter for aspiration. I note also that the Examiner found independent claims 1 and 11 (which matured into issued Claims 1 and 11 of the '910 Patent challenged here) to be allowable over Garrison precisely because Garrison fails to disclose "a second catheter advanceable through the first catheter; a second pressure source; and a fluid control device between the second catheter and the second pressure source," as recited in Claims 1 and 11. EX1002, pg.377. I agree.

76. Next, Petitioner creates a new demonstrative Figure not found in Garrison to allegedly show the features of independent Claims 1 and 11—first duplicating the valve 3325 shown in Figure 34 and then importing two of the valves 3325 into Figure 33.



Petitioner's Demonstrative FIG. 33.

Unmodified FIG. 33.

77. Petition, pg.51; *see also id.* at pgs.71-72 (relying on the same demonstrative regarding independent Claim 11). And, because Figure 33 does not have any valve such that there could not be any buildup of vacuum pressure with a valve, and there is no disclosure in Garrison of using the valve 3325 in Figure 34 to build up vacuum pressure when the valve is closed, Petitioner relies on yet a different embodiment of Garrison described in paragraph [0134] to allegedly show the claimed buildup and release of vacuum pressure:

In one embodiment, a locking syringe (for example a VacLok Syringe) is attached to the flow controller and the plunger is pulled back into a locked position by the user while the

connection to the flow line is closed prior to the thrombectomy step of the procedure. During the procedure when the tip of the aspiration device (either the arterial access device or the catheter) is near or at the face of the occlusion, the user may open the connection to the aspiration syringe. This would enable the maximum level of aspiration in a rapid fashion with one user.

EX1006, ¶[0134]; Petition, pgs.37-39 & 54-57. But that disclosure is for generating vacuum pressure with a syringe rather than with a peristaltic pump as shown in Figures 33 and 34 of Garrison, and that syringe is “attached” to the flow controller rather than a filter 3418 and a check valve 3419 like the peristaltic pumps in Figures 33 and 34. And, as I explain below, a POSITA would have understood that arrangement of the syringe described in paragraph [0134] to maximize the level of aspiration—while an arrangement in which the syringe is not directly connected to the flow controller would not maximize the level of aspiration.

78. A POSITA would not have been motivated to arrive at Petitioner’s purported combination shown in its demonstrative illustration of Figure 33 adding two valves into that system to build up vacuum pressure by mixing and matching Garrison’s various embodiments for several reasons. First, Garrison discloses various embodiments that utilize different aspiration sources, and in Figure 33 and 34 of Garrison, those aspiration sources are peristaltic pumps as I explain

above in §VI.A. Garrison also discloses similar pumps like centrifugal pumps. EX1006, ¶[0135]. But, contrary to Petitioner's explanation for its modified Figure 33 of Garrison, a POSITA would not have configured or operated Garrison's system to generate vacuum pressure using such pumps while those added valves were closed. Petition, pgs.54-55 & 37-38.

79. Namely, a POSITA would understand that such centrifugal and/or positive displacement continuous pumps are not intended to operate without fluid flow to their inlet. A POSITA would understand that running/operating a centrifugal, peristaltic, rotary, or a similar pump as disclosed by Garrison (and Laub (EX1012, ¶[0041]) and Aklog (EX1005, 12:9-14)) with the fluid inlet (i.e., suction inlet) closed as in Petitioner's proposed combination would starve the pump of fluid, causing the pump to run dry and potentially damaging the pump. In particular, without fluid flowing through the pump, the pump would "run dry" and experience significantly increased friction, cavitation, and overheating, potentially leading to mechanical failure. More specifically, with Garrison's added valves closed in Petitioner's purported combination, Garrison's pumps 3125/3425 would be unable to move fluid therethrough, thereby risking creating a vacuum that causes remaining fluid to boil and vaporize, destroying seals and bearings of the pump, while also cavitating and generating cavitation bubbles that could violently collapse within the pump and

damage the pump. Likewise, without fluid to remove heat, the internal casing temperature of Garrison's pump would rise rapidly, leading to eventual component failure. And, without fluid lubricating the pump components, the internal adjoining surfaces of Garrison's pumps could seize.

80. A POSITA would have readily understood for all the foregoing reasons that the continuous peristaltic/centrifugal pumps of Garrison would not be operated with a valve to the pump inlet closed shutting off fluid flow as Petitioner alleges. It is for precisely that reason that neither Garrison, Laub, or Aklog disclose any such valve for use with their continuous pumps. Garrison describes the pumps in Figures 33-34 as conventional "current sources of aspiration." EX1006, ¶[0135]. I understand that one such commercially available and conventional blood pump at the time of the invention of the '910 Patent was the Bio-Pump™ BP-50. Instructions for use for the BP-50 pump¹ describe the pump as a "centrifugal blood pump" having an inlet and outlet:

¹ While these instructions are dated September 12, 2018—after the priority date of the '910 Patent—I believe they reflect what POSA would have understood of how the BP-50 pump (which was commercially available as early as 1985 well before the priority date of the '910 Patent) should and should not be operated.

Figure 1. • Figura 1. • Figure 1.

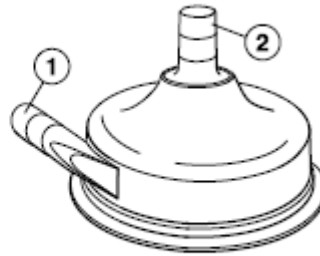

EN 1 Outlet
 2 Inlet

EX2009, pgs.5-6. And, as a POSITA would expect based on the operation of such pumps, I note that the instructions for use for the BP-50 pump specifically warned and instructed users: (1) “[d]o not operate the centrifugal blood pump for more than 30 s in the absence of flow ... [t]he temperature within the pump could rise,” (2) “[a]ttach tubing in a manner that prevents kinks or restrictions that may alter flow,” and (3) “[d]o not operate the centrifugal blood pump unprimed; damage to the internal components will occur.” *Id.* at pgs.7-8. I also note that similar instructions for using the BP-50 pump (or like pumps such as the larger BP-80 version) warn against operating the pump dry (without liquid therein) as would occur in Petitioner’s proposed combinations. EX2012, pgs.3, 5, 11. That is, the instructions for use for the BP-50 pump and other conventional blood pumps confirm what a POSITA would have understood—operating Garrison’s continuous centrifugal/positive displacement pumps without fluid flow therethrough (i.e., in the absence of flow, with kinks

or restrictions, and/or unprimed) as in Petitioner's proposed modification to Figure 33 could damage the pumps.

81. Similarly, I understand that another commercially available blood pump at the time of the invention was the ROTAFLOW Centrifugal Pump from Maquet, the instructions for use for which disclose that the "ROTAFLOW Centrifugal Pump (RF-32) has a spinning rotor with flow channels which imparts rotary motion to the incoming blood, directing it through a spiral housing to the out-flow port":

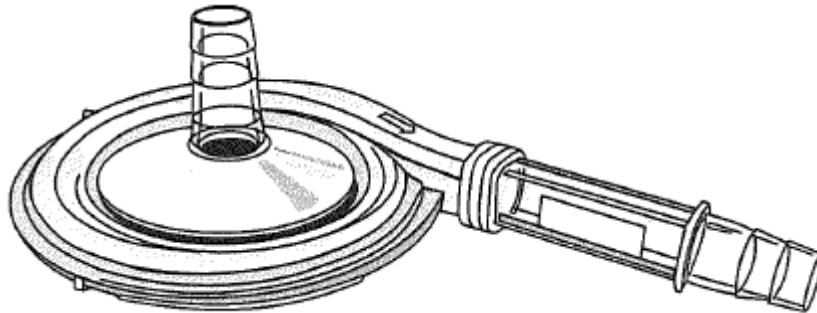

EX2010 , pgs.1 & 4. Again, unsurprisingly, the instructions for use for the ROTAFLOW Centrifugal Pump warned and instructed users: (1) "attach tubing in such a manner as to prevent kinks or any restrictions that may alter flow and (2) "[r]educe the pump speed to the minimum speed before clamping the tube, then turn the flow regulator to zero." *Id.* at pgs.4-5. That is, just like a POSITA would have understood, the ROTAFLOW pump is not intended to be operated without flow to its inlet. Those instructions for use likewise

confirm that a POSITA would have understood that operating Garrison's continuous centrifugal/positive displacement pumps without fluid flow therethrough (i.e., with kinks or restrictions, or with clamped tubing) as in Petitioner's proposed modification to Figure 33 is not advised.

82. Accordingly, a POSITA would not have modified Garrison to include two different valves that could and would operate to close off fluid flow while those pumps run as in Petitioner's proposed combination shown in its demonstrative illustration of Figure 33 because operating that modified system with the valves closed would likely damage the pumps.
83. And, while Garrison discloses the different locking syringe embodiment in paragraph [0134], that embodiment would not have led a POSITA to arrive at Petitioner's proposed modification of Figure 33 of Garrison. In particular, a syringe does not have continually moving parts like the continuous peristaltic pump in Figure 33 that can be damaged in the same manner when a valve is closed. And, while Garrison generally discloses that the aspiration source may be a pump or syringe, a POSA would not have substituted a syringe for the aspiration sources 3125,3425 in Figure 33 because it would lessen rather than maximize vacuum in the locking syringe embodiment of paragraph [0134], where Garrison discloses that the syringe is "attached" directly to a flow controller rather than indirectly via a filter and a check valve like the peristaltic

pump in Figure 34. EX1006, ¶[0134]. That arrangement maximizes the level of aspiration because there is a minimal volume (little or no dead space) between the syringe and valve (e.g., just the minimal space between the syringe tip and valve). In contrast, in Petitioner's proposed combination (using a syringe like paragraph [0134]), the filter 3418, check valve 3419, and associated tubing is between each syringe and the two valves 3325 such that the total volume between each of Garrison's syringes and Petitioner's added valves is greater than directly connecting the syringe to Garrison's valve. Put differently, the filter 3418, check valve 3419, and tubing increase the available volume for evacuation if Garrison's syringes were attached in place of the peristaltic pumps in Figure 33. That increased volume decreases the maximum achievable vacuum pressure because removing the same volume of fluid (Garrison's syringe volume) from a larger volume (including the filter 3418, check valve 3419, and associated tubing) rather than a smaller volume (the direct connection to the flow controller as Garrison teaches), results in less vacuum pressure. Specifically:

$$Pressure_{Final} = Pressure_{Initial} \left(\frac{Volume_{Initial} - \Delta Volume_{Removed}}{Volume_{Initial}} \right)$$

84. Accordingly, the initial volume controls the final vacuum pressure such that Petitioner's purported arrangement with syringes instead of the peristaltic pumps in Figure 33 would generate less vacuum pressure and a

correspondingly smaller “level of aspiration” than Garrison’s express disclosure of attaching the syringe to the flow controller where there is no intervening fluid volume with regard to paragraph [0134].

85. Taken altogether, a POSITA would not have been motivated to arrive at the configuration shown in Petitioner’s demonstrative illustration of Figure 33 of Garrison because closing Petitioner’s valves (allegedly added there) to operate Garrison’s peristaltic (or like) pumps 3125/3425 with those valves closed would damage the pumps. Even if aspiration power were momentarily increased by including a valve, a POSITA still would not have included such a valve because any subsequent aspiration might be hindered by degradation of the pump from starvation of fluid to the pump. And, a POSITA would not have used a syringe like in paragraph [0134] of Garrison in the arrangement of Figure 33 with the “fluid control device ... in the same position in modified Figure 33 [] (i.e., between the filter and the catheter as in Figure 34” (Petition, p.52) because that would significantly decrease the level of aspiration due to the intervening volume of the filters 3418, check valves 3419, and associated tubing—not enable the “maximum level of aspiration”—as Petitioner repeatedly touts as a motivation to combine. *Id.* at p38, 51, 53, 55.
86. Likewise, Petitioner’s assertion that a POSITA would have included valves in Figure 33 of Garrison, closed those valves while generating vacuum pressure

using the peristaltic pumps 3125/3425 in Figure 33, and subsequently opened those valves to apply vacuum pressure to “achieve ‘the maximum level of aspiration in a rapid fashion’” ignores the fundamental difference between a syringe and a peristaltic pump regarding the maximum achievable level of vacuum. Petition, pgs.51, 53; EX1003, ¶116. A syringe includes a barrel in which vacuum pressure is generated when a plunger is withdrawn. EX1006, ¶[0134]. That barrel has a fixed volume and that volume sets and thus limits the “maximum level of aspiration.” Therefore, when the syringe plunger is withdrawn with the flow controller closed as described in paragraph [0134] of Garrison, the maximum level of vacuum in the syringe is achieved because the full barrel is evacuated.

87. In contrast, peristaltic pumps like those shown in Figure 33 (and centrifugal and other positive displacement pumps) or do not have a fixed volume that limits the “maximum level of aspiration” but instead include a rotor rotated by a shaft such that rollers compress and seal tubing, alternating the compression and relaxation of the tubing to draw content into the pump through an inlet and propel that content away from the pump through an outlet:

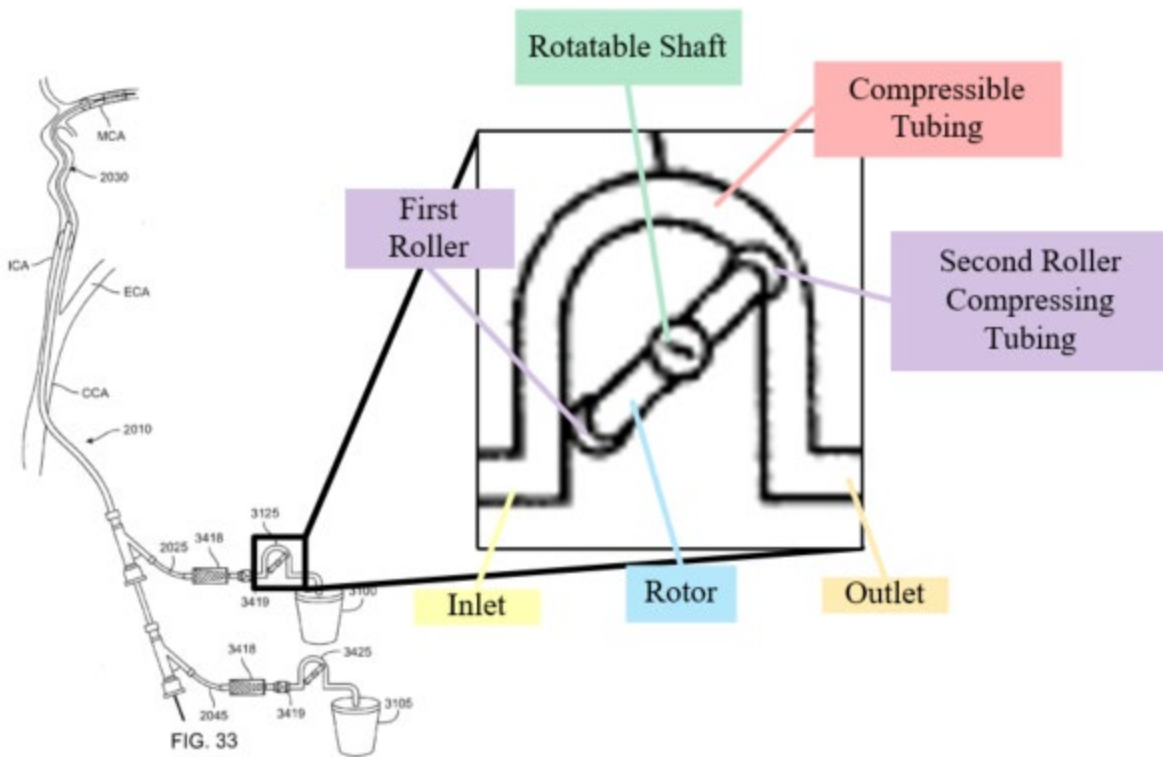

Generally, continuous pumps like peristaltic, centrifugal, and other positive displacement pumps operate to continuously shuttle fluid through a tube or conduit with a roller, vain, or the like. Accordingly, there is no fixed volume of the peristaltic pump that can be evacuated like a syringe if a valve were closed to generate a “maximum level of aspiration.” Any “maximum level of aspiration” is dictated by the speed of the pump—i.e., how quickly the rotor rotates to drive material through the pump—and there is not a fixed volume in the peristaltic pump like a syringe that would be evacuated to generate vacuum if a valve were included and closed.

88. Laub confirms this by disclosing that in a system using a pump (like Garrison) including a peristaltic pump (EX1012, ¶[0041]) the pump is controlled to generate different negative pressures (*id.* at ¶[0042]) and flow rates (*id.* at ¶[0043]-[0044]). In fact, Laub discloses that in the context of using large catheters and treating PE, “reinfusing the patient’s blood **continuously during aspiration allows for greater suction pressure and/or flow rates** (e.g., 2-4 L/min) which can assist in dislodging and removing larger clots and/or tumors than would otherwise be possible.” *Id.* at ¶[0045] (emphasis added). That is, Laub discloses that to achieve the “maximum level of aspiration” the system is operated continuously—which is the opposite of Petitioner’s proposed combination including a valve that is opened and closed. For those reasons, a POSITA would not have included valves in Figure 33 of Garrison to achieve maximum aspiration using the peristaltic pumps in those embodiments and would have, instead, simply increased the operational speed of the peristaltic pumps or operated the system continuously and not with valves opening and closing if increased or maximal aspiration were desired.
89. Indeed, including valves in Garrison’s system as Petitioner asserts would prevent continuous return and minimize aspiration pressure based on Laub. And, as I explain in further detail below in §VII.B., in the context of the Claims—large catheters used to treat PE—blood return is critical to patient safety and

a POSA would further not have modified Garrison's system in Figure 33 to include two valves instead of no valves because doing so would increase stasis of the blood in the system (i.e., non-continuous aspiration) and further exacerbate the unsuitability of the blood to be returned to the patient. EX1005, ¶[0135].

90. Next, because the arterial access device 2010 and the catheter 2030 are connected to the same pressure source 3430 in Figure 34, the valve 3325 “enables one device, the other device, both devices, or neither device to be connected to the aspiration source at any given time.” EX1006, ¶[0132]. A POSITA would understand that such control—i.e., switching the connection between the catheters to a single aspiration source—is not needed when the catheters are connected to separate aspiration sources (peristaltic pumps) as shown in Figure 33 because each peristaltic pump can be operated independently (e.g., turned off and turned on) such that there is no reason to include the valve 3325 from Figure 34. For example:

1. *Aspiration enabled to “one device”*: The peristaltic pump 3125 can be turned off to cease aspiration of the first catheter 2010 and the peristaltic pump 3425 can be turned on to aspirate the second catheter 2030.
2. *Aspiration enabled to the “other device”*: The peristaltic pump 3125 can be turned on to aspirate the first catheter

2010 and the peristaltic pump 3425 can be turned off to cease aspiration of the second catheter 2030.

3. *Aspiration enabled to “both devices”*: The peristaltic pump 3125 can be turned on to aspirate the first catheter 2010 and the peristaltic pump 3425 can be turned on to aspirate the second catheter 2030.
4. *Aspiration enabled to “neither device”*: The peristaltic pump 3125 can be turned off to cease aspiration of the first catheter 2010 and the peristaltic pump 3425 can be turned off to cease aspiration of the second catheter 2030.

Put differently, the valve 3325 of Figure 34 is used to control the connection of the catheters 2010 and 2030 to the same aspiration source, and that functionality is not needed when the catheters 2010 and 2030 are connected to different aspiration sources as shown in Figure 33.

91. Accordingly, Petitioner and its expert are incorrect that “a POSITA would have been motivated to position the valve at this location based on the description in Figure 34 that positioning the valve here allows the physician to effectively control suction through the catheters.” Petition, pg.52; EX1003, ¶114. That description in Figure 34 pertains to embodiments where the catheters are connected to the same—not different—pressure sources and, like I explain above, the physician can “effectively control suction through the

catheters” in Figure 33 by operating the separate pressure sources independently in that Figure.

92. For the same reasons Petitioner and its expert are also incorrect that “incorporating two separate valves into the system with two separate pressure sources would have given physicians more flexibility when using the device” by, for example, enabling “the user [to] control these independent pressure sources separately.” Petition, pg.52; EX1003, ¶115. Again, the pressure sources in Figure 33 can be operated independently without the inclusion of the valves Petitioner invents, such that a POSITA would not have been motivated to do so. Inclusion of the two additional valves requires an operator to operate two valves and two aspiration sources, i.e., turn on or off the aspiration source and also toggle the valve to operate the system, which needlessly complicates control and increases the difficulty of the procedure.
93. I see that Board preliminarily found these arguments unavailing because a POSA may “see a potential benefit in providing means to control each flow line (separate from, for example, directly turning the pressure sources on or off at the pressure source).” Institution Decision, pg.33. But, a POSA would understand any such benefit to be significantly outweighed by Petitioner’s proposed configuration in which Garrison’s continuous pumps shown in Figure 33 run without inlet flow—leading to pump damage.

94. Moreover, in Petitioner’s proposed combination “**the same valve (as shown in Figure 34)** [is] between each pressure source and catheter.” Petition, pg.51 (emphasis added). But a POSITA would not have been motivated to use the valve 3325 from Figure 34 in Figure 33—let alone include two of them—for the additional reason that the valve 3325 is a 3-way or 4-way stopcock or flow controller, which, as explained above is to allow connecting a single source of aspiration to two separate catheters. EX1006, ¶[0132]. Specifically, in Figure 34 the valve 3325 is attached to three separate tubing sections (i.e., the flow line 2025 to the arterial access device 2010, the flow line 2045 to the catheter 2030, and tubing to the filter 3418) and thus includes at least three different ports to connect to those tubing sections. But, in Petitioner’s combination each of the valves 3325 is attached only to two tubes (i.e., for one valve the flow line 2025 to the arterial access device 2010 and the tubing to the filter 3418, and for the other valve the flow line 2045 to the catheter 2030 and the tubing to the filter 3418) and controls the flow through a single flow line such that the valve 3325 (e.g., 3-way or 4-way stopcock or flow controller) would have at least one port not connected to anything and open to the surrounding environment.

95. More specifically, below I provide a schematic illustration of the different ports of the valve 3325 in Figure 34 and associated flow paths through the valve:

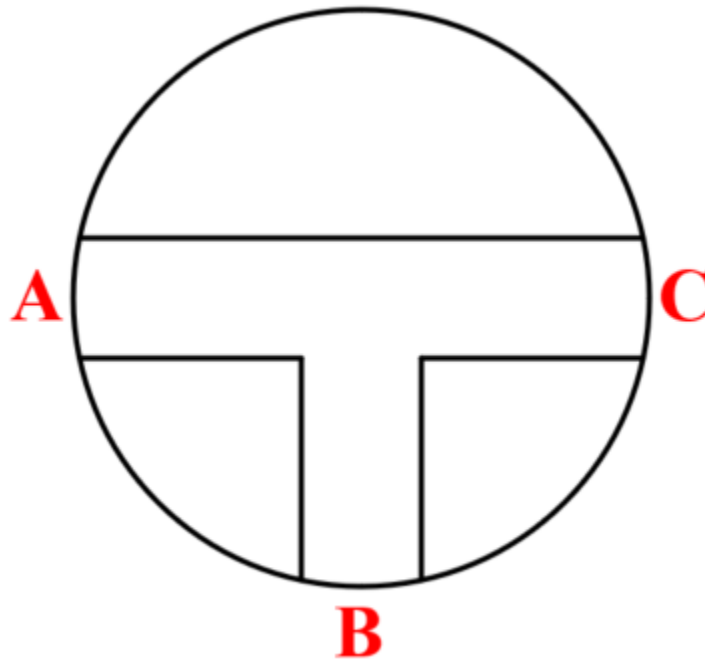

Port A connects to the flow line 2025 to the arterial access device 2010, port B connects to the flow line 2045 to the catheter 2030, and port C connects to the tubing to the filter 3418 and the aspiration source 3430. When the valve “enable[s] one device ... to be connected to the aspiration source” it connects only port A to port C to fluidly connect the aspiration source 3430 to the arterial access device 2010. EX1006, ¶[0132]. When the valve “enable[s] ... the other device ... to be connected to the aspiration source” it connects only port B to port C to fluidly connect the aspiration source 3430 to the catheter 2030.

Id. When the valve “enable[s] ... both devices ... to be connected to the aspiration source” it connects both ports A and B to port C to fluidly connect the aspiration source 3430 to the arterial access device 2010 and the catheter 2030. *Id.* Finally, when the valve “enable[s] ... neither device ... to be connected to the aspiration source” it connects neither port A nor port B to port C. *Id.*

96. In Petitioner’s proposed arrangement one of port A or port B would not be connected to anything (because there are only two tubes connected to each valve in Petitioner’s demonstrative illustration) and thus open to the surrounding environment. A POSITA would not include such a valve with a non-connected port in Garrison’s system first because it would complicate Garrison’s system and second because it would potentially endanger the patient. Specifically, if the valve were actuated to connect the non-connected port to the aspiration source, the system would needlessly suck air through the port and the aspiration source and drive it into the downstream receptacle. This would occur in two states of the valve: when both ports A and B are connected to the aspiration source via port C, and when the unconnected one of ports A and B is individually connected to the aspiration source via port C. As I explain detail below in §VII.B., a POSITA would understand based on Petitioner’s references that real-time blood return is critical when treating PE using large

catheters, and Petitioner asserts that a POSITA would operate Garrison with “a blood return solution” that operates “in real time during the procedure” when “upsizing Garrisons’ catheters to aspirate PEs.” Petition, pg.33; EX1006, ¶[0135]. But, a POSITA would understand the danger of potentially reinfusing air into the patient in Petitioner’s proposed modification to Figure 33 of Garrison. Namely, if either of Petitioner’s two valves 3325 were actuated to connect the pressure source to the unconnected port, air would be reinfused into the patient in real-time causing a dangerous and potentially deadly air embolism. For these reasons, a POSITA would not have used the valve 3325 of Figure 34 in Figure 33 as Petitioner asserts.

97. For the foregoing reasons, it is my opinion that Figure 33 and related description of Garrison relied on by Petitioner do not disclose the “first fluid control device” and the “second fluid control device” of independent Claim 1, or the “fluid control device” of independent Claim 11, or the buildup and subsequent release of vacuum pressure recited in those Claims (i.e., “[generating] vacuum pressure while the ... fluid control device is in the first position” and “wherein, upon movement of the ... fluid control device from the first position to the second position, the vacuum pressure is applied to the ... catheter to generate suction at the distal portion of the ... catheter”). And, it is my opinion that a POSITA would not have modified Figure 33 to include the two valves from

Figure 34 shown in Petitioner’s demonstrative illustration to somehow enable the claimed buildup and subsequent release of vacuum pressure because including such valves (1) would harm Garrison’s pumps via fluid starvation, (2) would not provide any increased control or function different than simply operating Garrison’s peristaltic pumps separately, (3) would provide dangerous flow paths for sucking air into the system through the unconnected port of the 3-way or 4-way stopcock that could be reinfused into the patient to cause an air embolism, and (4) would not enable a “maximum level of aspiration” because unlike a syringe, a peristaltic pump’s aspiration level is controlled by its operational speed rather than a fixed volume.

B. A POSITA Would Not Have Modified Garrison’s System to Treat PE or to Include a Second Inner Catheter Having a “Size of 16 French or Greater” Because Petitioner’s References Teach that Such a System Would Endanger the Patient Without Blood Return

98. Petitioner provides a modification to Figure 33 of Garrison—not found in Garrison as I explain in §VII.A. above—based on various embodiments in Figures 33 and 34 and paragraph [0134] of Garrison and asserts that that modification discloses all the features of independent Claims 1 and 11 except “for treating clot material comprising a pulmonary embolism” and wherein the second (e.g., inner telescoping) catheter “has a size of 16 French or greater” and “is shaped to be intravascularly advanced through the vasculature of the patient such that the distal portion of the second catheter is positioned

proximate to the pulmonary embolism.” Petitioner asserts that “[w]hile Garrison focuses on the ‘treatment of cerebral occlusions,’ a POSITA would have found it obvious to use and optimize Garrison’s clot treatment system to treat PE based on Laub or Aklog” and that a “POSITA would have found it obvious to upsize Garrison’s catheters from 8 French or 10 French to 16 French and greater than 16F for the larger first/outer catheter based on Laub and Aklog.” Petition, pgs.23-34 & 42-48.

99. But, a POSITA would not have used Petitioner’s modified system or any of the embodiments of Garrison relied on by Petitioner to treat PE—even if the catheter were “upsized”—because Petitioner’s references recognize the criticality of blood reintroduction to patient health and safety when treating PE, and Garrison expressly discloses that the embodiments relied on by Petitioner are not suitable for blood reintroduction. Moreover, Petitioner’s proposed combination, including adding valves to Figure 33 of Garrison, would actually add further opportunity for blood damage, particularly when those pumps operate without fluid flow to their inlet as described above.
100. As I explain in §VI.B. above, Laub discloses a system for removing clots, including PE, from a patient including a pump 400 that operates to continuously suction blood and thrombi through an aspiration catheter 200 and a filter

300 and then drive the filtered blood through a return catheter 500 back into the patient:

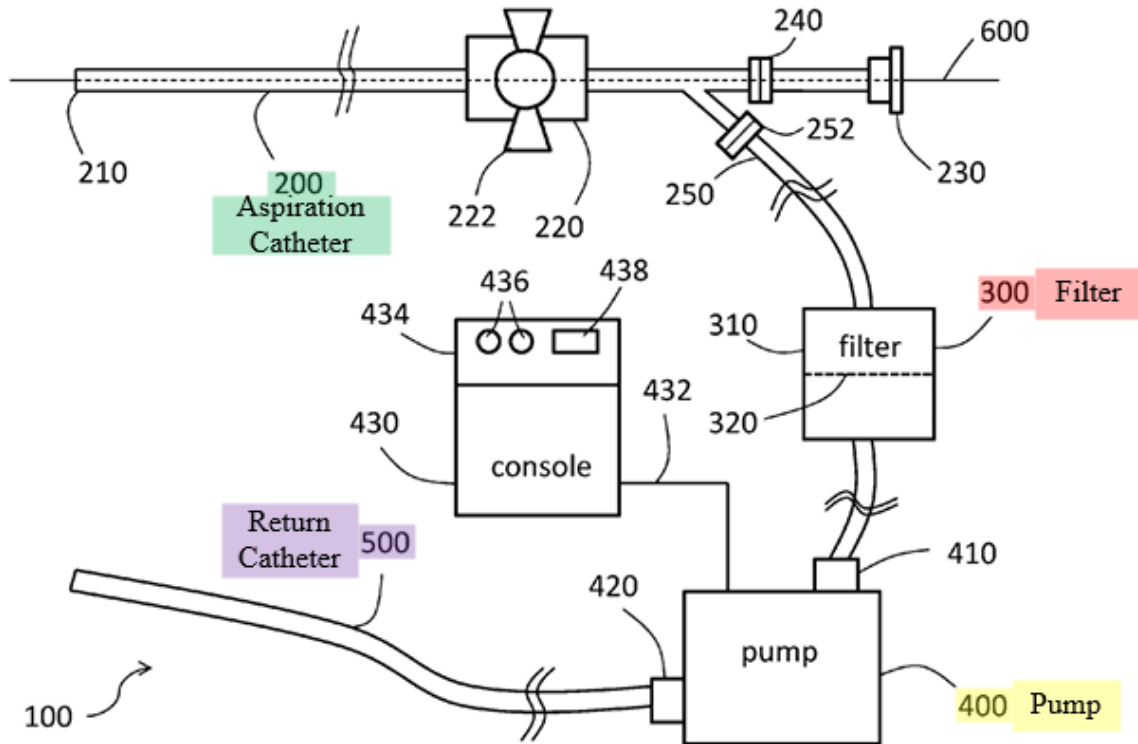

FIG. 1A

- EX1012, ¶¶[0005], [0024]. To effectively treat PE and other large clots, Laub discloses a relatively large aspiration catheter (in “preferred embodiments, aspiration catheter has a French size of equal to or greater than 10 Fr to allow for aspiration of large thrombi and/or other solid materials from the patient”) and high aspiration flow rates (up to “6000 mL/min”). *Id.* at ¶¶[0028], [0044].
101. Because of those large flow rates enabled at least partially by utilizing a large catheter, Laub correctly recognizes the necessity for blood reinfusion because of the large volume of blood removed from the patient: “Without returning

the blood back to the patient, such high flow rates could quickly result in exsanguination of the patient.” *Id.* at ¶[0045]. That is, the patient will bleed out and die or go into shock if the blood is not returned. “By returning the aspirated blood back to the patient, embodiments of the present system 100 allows for aspiration while minimizing the blood loss of the patient.” *Id.* Accordingly, a POSITA would understand from Laub that when using large catheters to treat PE, blood return is critical and that without it, such a system would endanger the patient.

102. As I explain in §VI.C. above, Aklog discloses a system for removing large clots, that like Laub includes a pump 15 that operates to continuously suction blood and thrombi through an aspiration catheter 10 and a filter device 14 and then drive the filtered blood through a reinfusion catheter 16 into the patient:

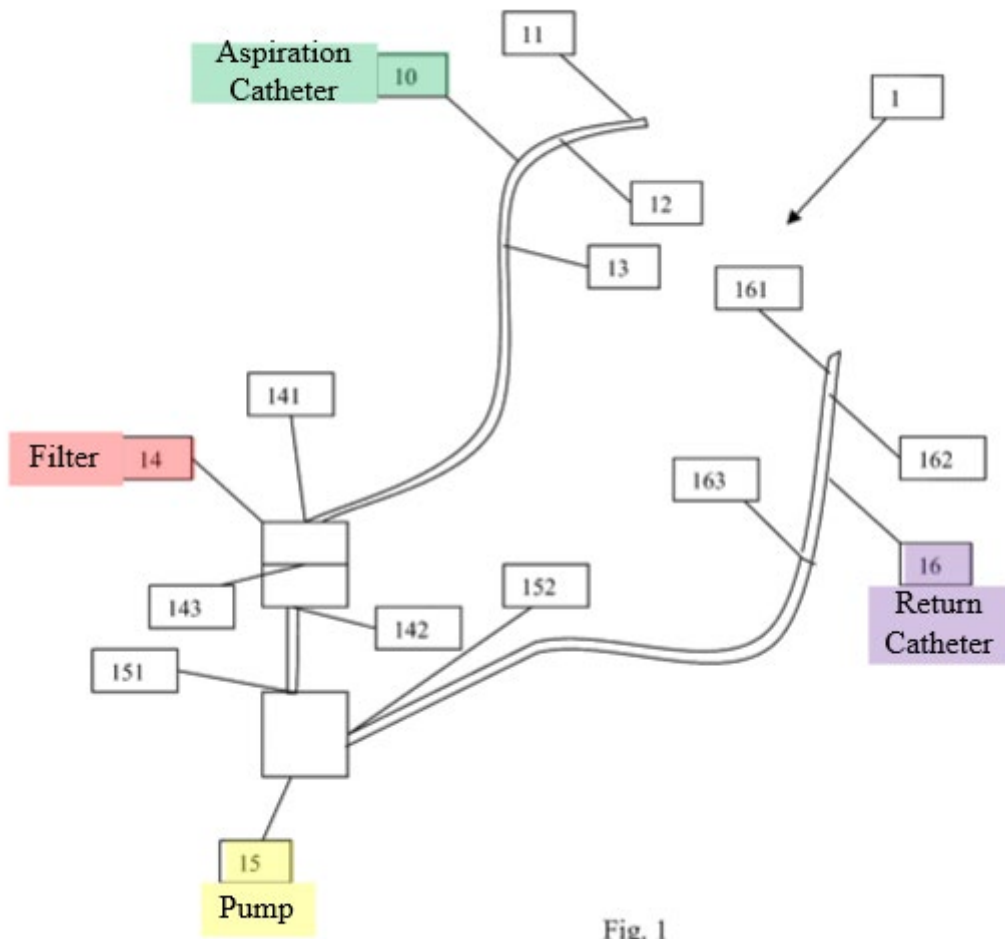

Fig. 1

EX1005, 11:24-12:34.

103. To effectively treat PE and other large clots, Aklog discloses a relatively large aspiration catheter (“the suction cannula 10 may be designed to remove at least 10 cm³ of undesirable material substantially en bloc”) and high aspiration volumes/flow rates (“suction cannula 11 ... when used around the heart and other large vessels, may displace a relatively large volume of fluid into and out of the patient's circulatory system”). *Id.* at 11:18-20, 19:57-62.

104. Because of those large aspiration volumes enabled at least partially by utilizing a large catheter, Aklog correctly recognizes the need for blood reinfusion: “[i]f the catheter is enlarged to accommodate the larger structure and material, such a catheter may aspirate an unacceptable volume of blood, resulting in excessive fluid loss and/or shock in the patient.” *Id.* at 7:23-26. That is, the patient will be harmed due to excessive blood removal if the blood is not returned. To address this, Aklog’s system “simultaneously reinfuse[s] aspirated (i.e., removed) and filtered fluid, such as blood, back into the patient on a substantially continuous basis to minimize any occurrences of fluid loss and/or shock.” *Id.* at 5:19-23. Accordingly, a POSITA would also understand from Aklog that when using large catheters to treat PE, blood return is critical and that without it, such a system would endanger the patient.

105. Both Laub and Aklog recognize the necessity to reintroduce blood when using large catheters to treat PE. But, Garrison itself discloses that the very embodiments relied on by Petitioner in Figures 33 and 34 and paragraph [0134] (the locking syringe embodiment) are not suitable for returning blood:

One disadvantage of current sources of aspiration is that the aspirated blood is received into an external reservoir or syringe. This blood is generally discarded at the end of the procedure, and as such represents blood loss from the patient. In addition, pumps such as centrifugal or peristaltic pumps are known to cause

damage to blood cells. Although it is possible to return blood from the external reservoir to the patient, the blood has been exposed to air or has been static for a period of time, and there is risk of thrombus formation or damage to the blood cells. Usually, aspirated blood is not returned to the patient to avoid risk of thromboembolism.

EX1006, ¶[0135]. In Figure 33 relied on by Petitioner, blood is pumped to the receptacles 3100/3105 (“external reservoir[s]”) where it remains “static” and is “exposed to air” such that it is not suitable for blood return. In Figure 34 relied on by Petitioner for disclosing a “fluid control device,” blood is likewise pumped to the receptacle 3430 (an “external reservoir”) where it remains “static” and is “exposed to air” such that it is not suitable for blood return. In the locking syringe embodiment disclosed in paragraph [0134], blood is aspirated into the syringe where it remains “static” such that it is not suitable for blood return. And, in Petitioner’s demonstrative to Figure 33 adding two of the single valve 3325 shown in Figure 34, the valves would add further stasis to Garrison’s system, causing the blood to remain static within the flow lines 2025/2045 distal to the valves when the valves are closed as I show below:

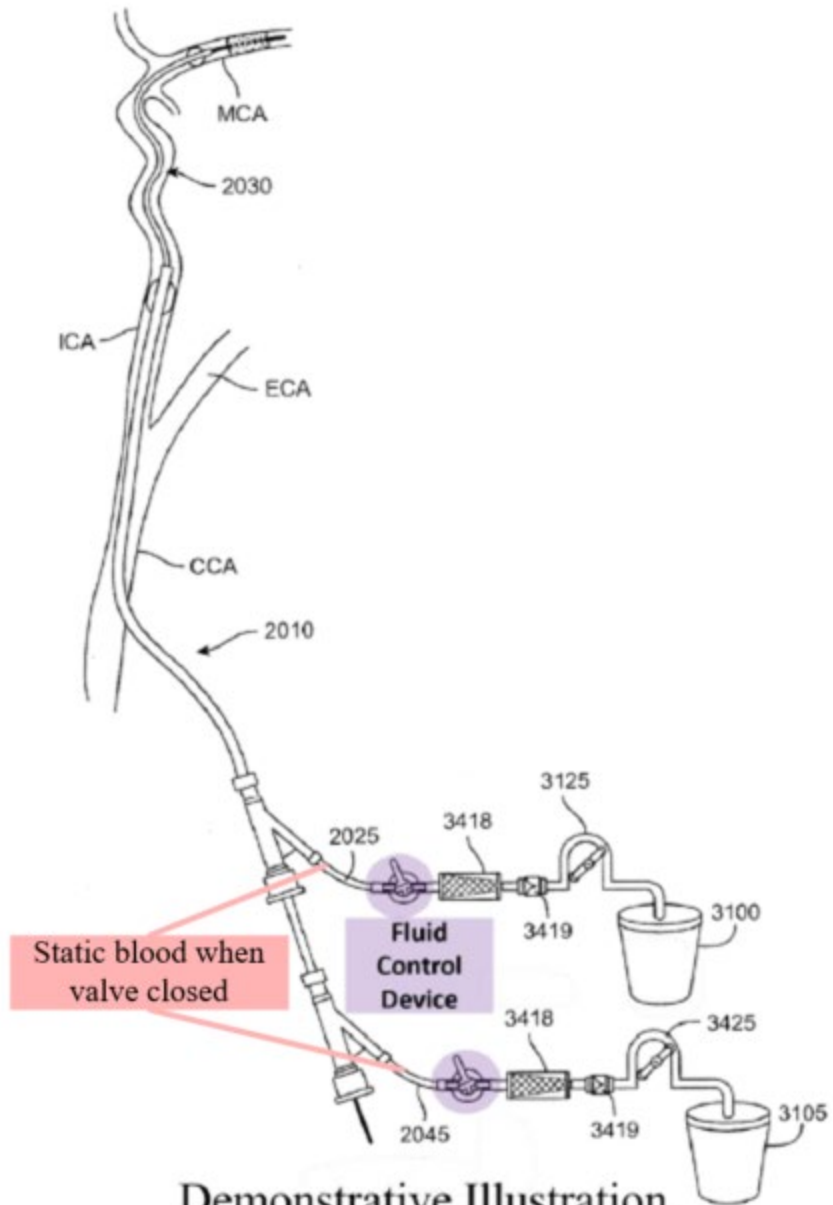

Demonstrative Illustration
Modified FIG. 33

106. Accordingly, a POSITA would understand based on Garrison’s express disclosure that in each embodiment of Garrison relied on by Petitioner the aspirated blood is not suitable for blood return and should be “discarded at the end of the procedure.” EX1006, ¶[0135]. For this reason, a POSITA would not

have “found it obvious to use and optimize Garrison’s clot treatment system to treat PE based on Laub or Aklog” or “found it obvious to upsize Garrison’s catheters from 8 French or 10 French to 16 French or greater based on Laub and Aklog” because Laub and Aklog each emphasize the critical nature of blood return for patient health when treating PE using large catheters—and Garrison discloses that the embodiments relied on by Petitioner are not suitable for blood return. Petition, pgs.23-34 & 42-48. As such, a POSITA would not optimize Garrison’s system in a manner not disclosed by Garrison and in a manner discouraged by Garrison and both Laub and Aklog.

107. What’s more, utilizing the embodiment in Petitioner’s proposed modifications to Figure 33 of Garrison would further harm blood if it were to be returned as taught by Laub and Aklog to treat PE. For example, a POSITA would understand that utilizing Garrison’s pump(s) to generate vacuum pressure with the added valves closed as in Petitioner’s modification to Figure 33 of Garrison would be dangerous to the patient by harming blood meant for return. As I explain in section §VII.A. directly above, closing a valve to Garrison’s peristaltic pumps shown in Figure 33 and operating those pumps would likely damage those pumps due to pump starvation—i.e., no fluid flow through the fluid inlet of the pump. Even if those pumps could somehow be operated without damage in such a state, a POSITA would understand that such an operating

state would damage the blood in Garrison's system such that it was even more unsuitable and unsafe for blood return.

108. Specifically, the same conditions such as increased friction, overheating, etc., that act to damage the pump in a starvation (i.e., no-inflow) state as in Petitioner's purported combination would also act to damage blood already in the system. For example, a POSITA would understand that heating blood or repeatedly contacting that blood could lead to blood damage. I note that in alignment with that understanding, the instructions for use for the BP-50 pump specifically warned that "in the absence of flow ... [t]he temperature within the pump could rise and *increased cellular damage* may result." EX2009, pg.7 (my emphasis added). Likewise, the instructions for use for the ROTAFLOW Centrifugal Pump instructed the user to reduce flow to zero to prevent hemolysis of blood (i.e., the destruction of red blood cells) when a tube to the pump is clamped: "when clamping the tube: ... turn the flow regulator to zero *to prevent hemolysis*." EX2010, pg.5 (my emphasis added). Those instructions confirm that a POSITA would have understood that operating the aspiration sources 3125/3425 of Garrison with Petitioner's added valves closed as in Petitioner's proposed modification to Figure 33 of Garrison would further damage blood in that system.

109. I see that in the Institution Decision, the Board preliminarily found that Patent

Owner's arguments in its Preliminary Response regarding blood return did "not undermine Petitioner's challenge at this stage" based on a number of preliminary observations (1)-(5). Institution Decision, pgs.37-38. I disagree with those preliminary observations; a POSITA would not have found it obvious—and in fact would have found it disadvantageous and dangerous—to duplicate Garrison's valve 3325 and add those valves to Figure 33 to build up vacuum pressure as proposed by Petitioner.

110. More specifically, the Board's preliminary observation (1) that Garrison teaches an embodiment in Figure 36 that is compatible with blood return actually reinforces that a POSITA would not have added a valve—let alone two valves—to Figure 33 of Garrison as proposed by Petitioner. Institution Decision, pg.37. Indeed, Garrison expressly contrasts the embodiments relied on by Petitioner (Figures 34 and paragraph [0134]) that are unsuitable for blood return with the embodiment in Figure 36 "which is configured not to harm blood cells and which may be configured to return blood to the central venous system *in real time* during the procedure, so there is no reservoir in which the blood remains static." EX1006, ¶[0136] (my emphasis added). So just, like Laub and Aklog, Garrison's embodiment in Figure 36 that is suitable for blood return operates to continuously return blood without any intervening valve that is closed to generate vacuum. *See*, e.g., EX1012, ¶[0045] ("reinfusing the

patient's blood continuously during aspiration allows for greater suction pressure and/or flow rates (e.g., 2-4 L/min) which can assist in dislodging and removing larger clots and/or tumors than would otherwise be possible.”); EX1005, 5:19-23 (which “simultaneously reinfuse[s] aspirated (i.e., removed) and filtered fluid, such as blood, back into the patient on a substantially continuous basis to minimize any occurrences of fluid loss and/or shock.”). A POSITA would not have used a valve in Figure 36 of Garrison—a positive displacement pump—with the inlet clamped to starve the pump of fluid flow for the same reasons I explain above (i.e., pump damage, blood damage). And, each of Garrison, Laub, and Aklog disclose continuous aspiration and reinfusion when blood is returned to the patient. A POSITA would understand such systems to be incompatible with the challenged Claims including the treatment of PE, a “16 French or greater” inner catheter, and the “fluid control device[s]” that enable vacuum pressure to be generated “while the ... fluid control device is in the first position” inhibiting fluid flow therethrough because the fluid control device would prevent continuous reinfusion and aspiration.

111. Regarding the Board's preliminary observation (2) that Laub and Aklog “teach that aspirated blood (including blood aspirated with conventional pumps, like centrifugal or peristaltic pumps) can safely be returned to the

patient,” even so neither those references nor Garrison disclose that blood can safely be returned in a system like Petitioner’s proposed combinations including a valve between the aspiration catheter and a peristaltic/centrifugal/positive displacement pump. Institution Decision, pg.38. Indeed, as I detail above, a POSITA would have understood that such a modification would further damage the blood for reinfusion to the patient.

112. Similarly regarding the Board’s preliminary observation (3), even if Laub and Aklog can run “intermittently,” a POSITA would understand that intermittent operation does not mean using a valve to shut off fluid flow and build vacuum pressure while those pumps operate. Institution Decision, pg.38. Instead, intermittent operation simply means turning the pump on or off with the pump inlet and pump outlet unobstructed (i.e., without closure of any valve) to prevent pump starvation and the negative consequences I describe above.
113. Likewise, regarding the Board’s preliminary observation (4), a POSITA would not have added valves to Figure 33 of Garrison and operated that modified system to build up pressure as alleged by Petitioner to provide any “rapid burst of suction pressure” based on the potential for pump and blood damage. Institution Decision, pg.38. Finally, regarding the Board’s preliminary observation (5) that “the valve closure and vacuum generation would seem to be a temporary step to enable a rapid burst of suction—*without blood being*

withdrawn from the patient during this brief window,” a POSITA would understand that it is precisely because blood or other fluid is not being withdrawn while the pump operates in Petitioner’s proposed combination that pump damage and blood damage would occur. *Id.* (my emphasis added).

114. Petitioner simply asserts that “Garrison already accounts for one challenge POSITAs encountered when moving from smaller to larger aspiration catheters – a larger catheter ‘may aspirate an unacceptable volume of blood, resulting in excessive fluid loss and/or shock in the patient’” based on the embodiment in Figure 36 of Garrison. Petition, pg.33. But, as I explain above, a POSITA would understand that embodiment not to include any “fluid control device” as recited in Claims 1 and 11 to prevent pump and blood damage, and to enable continuous aspiration and reinfusion. And, that embodiment is different than the embodiment in Figures 33 and 34.

C. A POSITA Would Not Have Modified Garrison to Include a Catheter Having a Second Inner Catheter With “Size of 16 French or Greater” Because Such a Modification Would Prevent Garrison’s System from Being Positioned in The Cerebral Vasculature

115. A POSITA would also not “have found it obvious to upsize Garrison’s catheters from 8 French or 10 French to 16 French or greater for the second (smaller) inner catheter and larger than 16F for the larger outer (first) catheter based on Laub and Aklog” because doing so would render Garrison unsuitable for its express purpose of treating cerebral clots. Petition, pg.42. As Petitioner

admits, “Garrison focuses on the ‘treatment of cerebral occlusions.’” *Id.* at pg.24. Indeed, Garrison discloses “methods and systems for transcarotid access of the cerebral arterial vasculature and treatment of cerebral occlusions.” EX1006, ¶[0002]. Because the cerebral vasculature is much smaller than the vasculature for treating pulmonary embolism, Garrison only discloses catheters much smaller than 16 French, such as 6 or 8 French. *See id.* at ¶[0063] (“In an embodiment, the sheath body 222 can have an inner diameter of about 0.087” and an outer diameter of about 0.104”, corresponding to a 6 French sheath size. In another embodiment, the sheath body 222 has an inner diameter of about 0.113” and an outer diameter of about 0.13”, corresponding to an 8 French sheath size.”).

116. In Figures 33 and 34 of Garrison relied on by Petitioner, the inner catheter 2030 is positioned in the middle cerebral artery (MCA) to treat a cerebral clot therein:

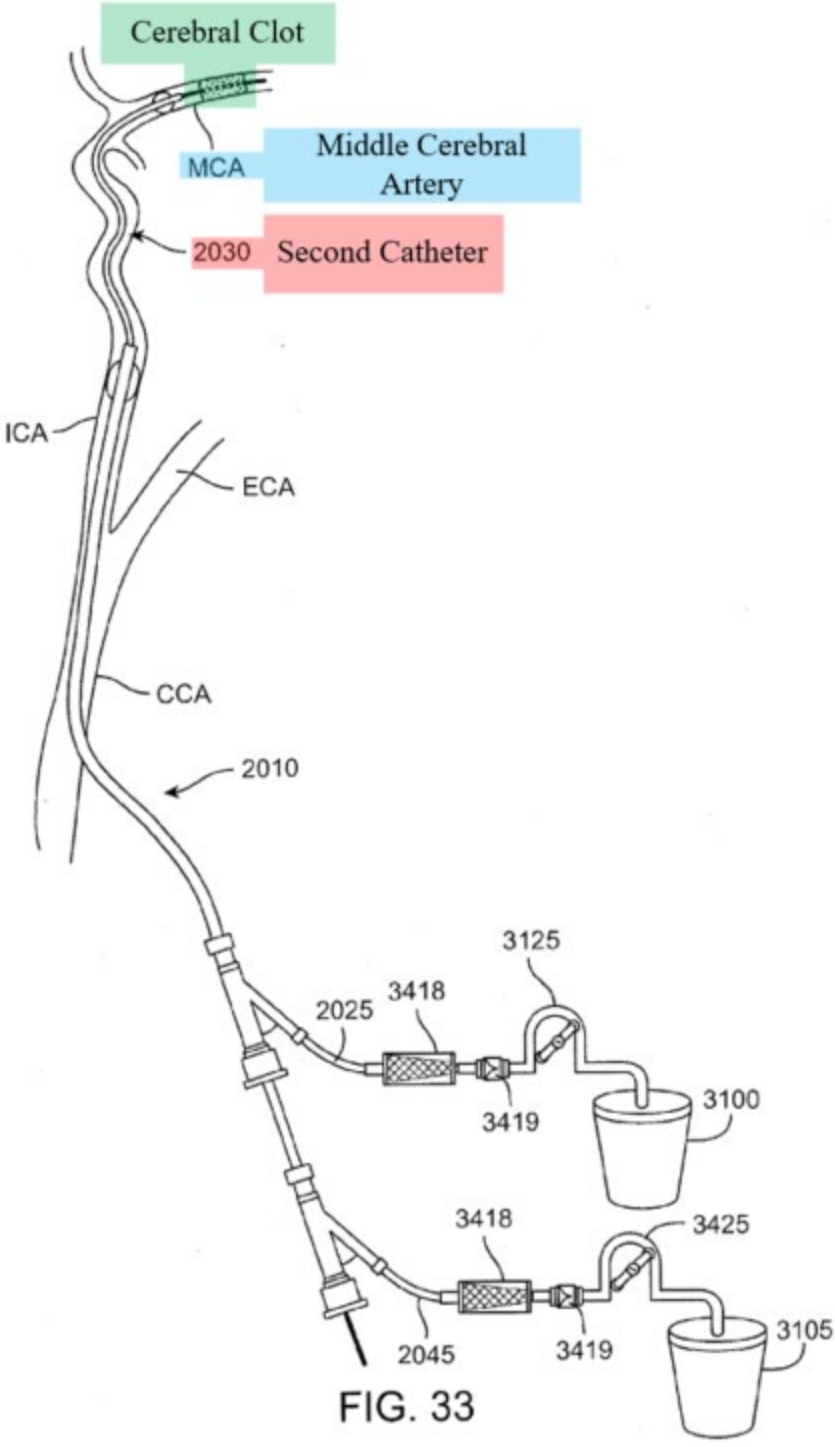

A POSITA would understand that if the catheter 2030 were upsized to have a size of “16 French or greater” as recited in Claims 1 and 11, the catheter 2030

could not be positioned in the MCA and would not be able to treat the cerebral clot therein. For example, the mean diameter of the MCA is about $2.55 \pm .42$ mm. EX2004, pgs.5-7. 16 French is 5.1 mm in diameter (1 French is $\sim 1/3$ mm diameter) which is substantially $\sim 200\%$ greater than the mean vessel diameter of the MCA. For clarity, French is a measurement of the circumference of a catheter in millimeters such that a 1 French catheter has a circumference of 1 mm and a diameter of $= (1 \text{ mm}) / (\pi)$, or $\sim 1/3$ mm diameter. Accordingly, if the catheter 2030 were “16 French or greater” in size it would not be able to fit into the MCA. *See id.* at pg.2. (noting that if the MCA was close to the size of the catheter “the catheter may have struggled to fit appropriately within the vessel”). A POSITA would also understand that trying to advance a 16 French or greater catheter into the MCA would likely endanger the patient because it could damage the MCA. Put another way, upsizing Garrison’s catheter from 8 French or smaller to 16 French or greater would massively increase the cross-sectional area of the catheter by four times.

117. Similarly, with a 16 French or greater inner catheter, a POSITA would understand that the outer “first catheter” through which the inner catheter is advanced must be larger to allow the inner catheter to fit therethrough. In Figures 33 and 34 of Garrison, the arterial access device 2010 (i.e., Petitioner’s alleged “first catheter”) is positioned in the internal carotid artery (ICA). The largest

mean diameter of the ICA is 4.74 ± 0.64 mm. *Id.* at pgs.5-6. But even assuming a 1 French size difference between the catheters, if the arterial access device 2010 were 17 French (5.4 mm) it would not fit in the ICA ($5.4 \text{ mm} > 4.74 \pm 0.64 \text{ mm}$).

118. Accordingly, a POSITA would not have upsized the catheter 2030 of Garrison because it would render Garrison's system unsuitable for its intended purpose of treating cerebral clot, and more particularly, clot in the MCA. I note also, the Examiner of the '910 understood these distinctions, explaining in the Notice of Allowance:

Claims 1 and 11 are allowable for reciting, inter alia, "a clot treatment system for treating clot material comprising a pulmonary embolism in the vasculature of a patient" and "wherein the second catheter has a size of 16 French or greater".

Garrison (US 20150173782 A1) ... fails to teach a ["clot treatment system for treating clot material comprising a pulmonary embolism in the vasculature of a patient" and "wherein the second catheter has a size of 16 French or greater". The clot treatment device of Garrison is configured for a neurovascular application and not for larger vasculature such as pulmonary embolism. It would be unreasonable to modify the clot treatment device of Garrison to be used for pulmonary embolisms. There is no prior art that teaches all of the limitations. Therefore, claims 1 and 11 are allowable.

EX1002, pg.49. That is, the Examiner correctly found that it would be unreasonable to modify Garrison to include a 16 French catheter or to treat PE.

VIII. GROUNDS 4-9: THE COMBINATIONS OF GARRISON AND LAUB AND/OR AKLOG FURTHER IN VIEW OF HARTLEY OR PASHA AKLOG DOES NOT RENDER OBVIOUS ANY OF CLAIMS 3, 6-7, 12, 18, OR 20

119. As I explain §VII. above, independent Claims 1 and 11 are not rendered obvious by Garrison in combination with Laub and/or Aklog. Dependent Claims 3 and 6-7 depend from independent Claim 1, and dependent Claims 12, 18, and 20 depend from independent Claim 11. Petitioner does not allege that Hartley (grounds 3-6; Claims 6-7 and 20) or Pasha (grounds 7-9; Claims 3, 12, and 18) disclose any of the features of independent Claims 1 or 11. Therefore, these claims are also not rendered obvious by Garrison in combination with Laub and/or Aklog and further in view of Hartley (grounds 4-6) or Pasha (grounds 7-9) because they incorporate all the features of their respective independent Claims 1 or 11.

IX. SECONDARY CONSIDERATIONS

120. I have not rendered any opinions on secondary considerations of non-obviousness at this time, but reserve the right to do so.

X. CONCLUSION

121. For all the above reasons, I find that Petitioner has not met its burden of demonstrating the unpatentability of any challenged claim. Accordingly, I

understand that Patent Owner requests the Board confirm the patentability of
Claims 1–20.

Declaration of Brian Brown

I, Brian Brown, declare that all statements made herein of my knowledge are true, and that all statements made on information and belief are believed to be true, and that these statements were made with the knowledge that willful false statements and the like so made are punishable by fine or imprisonment, or both, under Section 1001 of Title 18 of the United States Code.

Respectfully submitted,

Dated: *12 MAR 2026*

By:



Brian Brown

ATTACHMENT 1

Brian J. Brown

C (763) 458-8551

bb.browntech@gmail.com

Professional Experience

Brown-Tech , LLC. Hanover, MN **Sept 2017-Present**
President

- Technical Consultant for early stage medical device companies in the areas of product design and intellectual property development (clients: Peytant Solutions, QXMedical, CardioMech)
- Subject Matter Expert for Medical Device patent cases ranging from litigation to Inter Partes Reviews. Responsible for case document reviews, product testing, testing reports, POSA declarations, depositions and testimony.

Brown-Tech , LLC. (Nitinol) Maple Plain, MN **Mar 2018-July 2020**
President

- Specialized contract Nitinol design and prototyping for small to large nitinol projects.
- Expertise in the areas of design, laser cutting, shape setting, grit blasting, electro-polishing, passivation and testing.
- Over 25 years of expertise with nitinol stents, guidewires, structural heart, heart failure and misc. components.

Cogentix Medical Inc. Minnetonka, MN **Nov 2016 - June 2017**
VP of R&D and Operations

Pelvic Health medical device company developing and commercializing neurostimulators, endoscopes and sphincter bulking agents.

- Responsible for production, R&D, supply chain, planning, QC and Customer Care in MN, NY, and MA
- Owned cross functional leadership of New Business Development and Strategic Growth activities
- Provided oversight of Corporate intellectual property portfolio, outside counsel activities, and patents

OvaGene Oncology Irvine CA and Edina, MN **2016**
Chief Technology Officer

A Point of Care (POC) molecular diagnostic company focused on developing and commercializing a diagnostic (Dx) microfluidic chip capable of running self-contained, protein based diagnostic assays.

- Developed a commercial version of a research lab POC Dx prototype
- Sr. Staff member responsible for R&D, Intellectual Property, Operations, Quality, Regulatory, Facilities, and IT.

Sunshine Heart, Inc Eden Prairie, MN **June 2014 - Jan 2016**
Sr. Vice President Technology and Operations

An early-stage, publicly traded medical device company focused on developing, manufacturing and commercializing the C-Pulse System for the treatment of Class III and ambulatory Class IV heart failure.

- Sr. Staff member responsible for R&D, Operations, Facilities, and IT.
- Led the organizational development /optimization of electromechanical, mechanical, sensor and software components for a Class III permanent implant supported by an external controller.
- Led the portfolio planning and technology roadmap efforts for strategic planning
- Provided oversight of Corporate intellectual property portfolio, outside counsel activities, and patents

Boston Scientific Corporation / SciMED, Maple Grove, MN Feb 1990 – Jan 2014
R&D, Vice President, Cardiovascular (2004-2014)

Directed worldwide Cardiovascular research and development activities for accelerated launches of implantable stents, drug delivery technologies, structural heart devices, disposable catheters and adjunctive products.

- Developed, sustained, and optimized a \$200M/yr. international R&D organization to bring the right new technologies / products to the market
- Aligned company's technology development, M&A activities, and IP portfolio
- Initiated Bio Design partnerships with regional / global research institutions to identify / develop disruptive technologies to fuel future growth.

R&D, Sr. Director, Stents

Created R&D stent and drug elution centers of excellence in MN and Ireland (2001- 2004)

- Championed / built a stent organization bringing BSC's first internally developed nitinol and stainless steel stents to the market.
- Constructed / maintained a world class dual site drug elution organization capturing 70% of the global market launching the Taxus and Promus portfolio of stent products.
- Identified / engaged the technical assessment of business opportunities and integration of new licenses / acquisitions.

Prior History

Previously at Boston Scientific / SciMED held positions of R&D Director Catheters, R&D Director / Manager Stents, Operations Manager Guidewires, Sr. Process Development Engineer, and Sr. Machine Design Engineer. Highlights included developing BSC's core competency in nitinol, stent design, laser cutting, electropolishing, crimping, and fatigue testing. Many ground breaking design, clinical and regulatory competencies were developed to support Boston Scientific's first cardiovascular permanent implants.

Hutchinson Technology (Sep 1984-Jan 1990) as Machine Design Engineer / Supervisor responsible for building and leading equipment / process automation for a rapidly growing company. Examples include automated passivation lines, plating lines, photochemical etching lines, and laser equipment.

Education / Affiliations

North Dakota State University, Fargo, ND

Bachelor of Science, Mechanical Engineering with an emphasis on electro-mechanical automation.

Notable Achievements

- **~60 issued US Patents** in stent geometries, nitinol, balloon catheters, thrombectomy catheters, infusion catheters, and ePTFE processing.
- **Boston Scientific Patent of the Year award, two-time winner**
- **Recognized as one of Minnesota's leading inventors** by the Twin Cities Business Magazine (Jan 13)
- **Developed Boston Scientific's first product development process and design control tools.**
- **Elected to College of Fellows**, American Institute for Medical and Biological Engineering
- **Advisor to University of MN Office of Technology Commercialization** to advance the commercialization of university developed ideas
- **Mentor** for students enrolled in the University of MN Design of Medical Device program.

USA PATENT NUMBER	TITLE	Listed Inventor	GRANT DATE
5358493	VASCULAR ACCESS CATHETER AND METHODS FOR MANUFACTURE THEREOF	Brian J Brown	25-Oct-94
5417703	THROMBECTOMY DEVICES AND METHODS OF USING SAME	Brian J Brown	23-May-95
5419774	THROMBUS EXTRACTION DEVICE	Brian J Brown	30-May-95
5507995	PROCESS FOR MAKING A CATHETER	Brian J Brown	16-Apr-96
5800517	STENT DELIVERY SYSTEM WITH STORAGE SLEEVE	Brian J Brown	1-Sep-98
6013091	STENT CONFIGURATIONS	Brian J Brown	11-Jan-00
6059810	ENDOVASCULAR STENT AND METHOD	Brian J Brown	9-May-00
6096056	FUGITIVE STENT SECUREMENT MEANS	Brian J Brown	1-Aug-00
6123720	STENT DELIVERY SYSTEM WITH STORAGE SLEEVE	Brian J Brown	26-Sep-00
6261319	STENT	Brian J Brown	17-Jul-01
6348060	FUGITIVE STENT SECUREMENT MEANS	Brian J Brown	19-Feb-02
6348065	LONGITUDINALLY FLEXIBLE EXPANDABLE STENT	Brian J Brown	19-Feb-02
6409753	FLEXIBLE STENT	Brian J Brown	25-Jun-02
6416538	STENT CONFIGURATIONS	Brian J Brown	9-Jul-02
6428569	MICRO STRUCTURE STENT CONFIGURATIONS	Brian J Brown	6-Aug-02
6451052	TISSUE SUPPORTING DEVICES	Brian J Brown	17-Sep-02
6471672	SELECTIVE HIGH PRESSURE DILATION BALLOON	Brian J Brown	29-Oct-02
6478816	STENT	Brian J Brown	12-Nov-02
6551351	SPIRAL WOUND STENT	Brian J Brown	22-Apr-03
6582461	IMPROVED TISSUE SUPPORTING DEVICES	Brian J Brown	24-Jun-03
6602226	LOW-PROFILE STENT DELIVERY SYSTEM AND APPARATUS	Brian J Brown	5-Aug-03
6638468	METHOD OF REDUCING THE WALL THICKNESS OF A PTFE TUBE	Brian J Brown	28-Oct-03
6702843	STENT DELIVERY DEVICE WITH BALLOONS	Brian J Brown	9-Mar-04
6776793	LONGITUDINALLY FLEXIBLE EXPANDABLE STENT	Brian J Brown	17-Aug-04
6818014	IMPROVED LONGITUDINALLY FLEXIBLE EXPANDABLE STENT	Brian J Brown	16-Nov-04
6852123	MICRO STRUCTURE STENT CONFIGURATIONS	Brian J Brown	8-Feb-05
6911038	MATCHED BALLOON TO STENT SHORTENING	Brian J Brown	28-Jun-05
6913619	IMPROVED LONGITUDINALLY FLEXIBLE EXPANDABLE STENT	Brian J Brown	5-Jul-05
6939119	METHOD OF REDUCING THE WALL THICKNESS OF A PTFE TUBE AND PRODUCT FORMED THEREBY	Brian J Brown	6-Sep-05
6945993	STENT	Brian J Brown	20-Sep-05
6962603	IMPROVED LONGITUDINALLY FLEXIBLE EXPANDABLE STENT	Brian J Brown	8-Nov-05
6970734	FLEXIBLE MARKER BANDS	Brian J Brown	29-Nov-05
6981985	STENT BUMPER STRUTS	Brian J Brown	3-Jan-06
6981986	IMPROVED LONGITUDINALLY FLEXIBLE EXPANDABLE STENT	Brian J Brown	3-Jan-06
7060089	MULTI-LAYER STENT	Brian J Brown	13-Jun-06
7204848	LONGITUDINALLY FLEXIBLE EXPANDABLE STENT	Brian J Brown	17-Apr-07
7229470	FLEXIBLE STENT	Brian J Brown	12-Jun-07
7318836	COVERED STENT	Brian J Brown	15-Jan-08
7326243	AN IMPROVED STENT	Brian J Brown	5-Feb-08
7331986	INTRALUMINAL MEDICAL DEVICE HAVING IMPROVED VISIBILITY	Brian J Brown	19-Feb-08
7335225	[IMPROVED] STENT CONFIGURATIONS	Brian J Brown	26-Feb-08
7488343	MEDICAL DEVICES	Brian J Brown	10-Feb-09
7491225	SYSTEM AND METHOD FOR DEPLOYING A DRUG-ELUTING EXTERNAL BODY AND TISSUE SCAFFOLD	Brian J Brown	17-Feb-09

IPR2025-01025
First Attachment to Declaration of Brian Brown

USA PATENT NUMBER	TITLE	Listed Inventor	GRANT DATE
7637938	FLEXIBLE STENT	Brian J Brown	29-Dec-09
7731746	AN IMPROVED STENT	Brian J Brown	8-Jun-10
7879082	MICRO STRUCTURE STENT CONFIGURATIONS	Brian J Brown	1-Feb-11
7914570	NON-SHORTENING HELICAL STENT	Brian J Brown	29-Mar-11
7951187	[IMPROVED] STENT CONFIGURATIONS	Brian J Brown	31-May-11
7988717	LONGITUDINALLY FLEXIBLE EXPANDABLE STENT	Brian J Brown	2-Aug-11
7988720	LONGITUDINALLY FLEXIBLE EXPANDABLE STENT	Brian J Brown	2-Aug-11
8038705	INTRALUMINAL MEDICAL DEVICE HAVING IMPROVED VISIBILITY	Brian J Brown	18-Oct-11
8043366	OVERLAPPING STENT	Brian J Brown	25-Oct-11
8114146	LONGITUDINALLY FLEXIBLE EXPANDABLE STENT	Brian J Brown	14-Feb-12
8147538	COVERED STENT	Brian J Brown	3-Apr-12
8206432	STENT	Brian J Brown	26-Jun-12
8221491	IMPROVED TISSUE SUPPORTING DEVICES	Brian J Brown	17-Jul-12
8348992	IMPROVED LONGITUDINALLY FLEXIBLE EXPANDABLE STENT	Brian J Brown	8-Jan-13
8377111	MEDICAL DEVICES	Brian J Brown	19-Feb-13
8449597	LONGITUDINALLY FLEXIBLE EXPANDABLE STENT	Brian J Brown	28-May-13
8668731	STENT	Brian J Brown	11-Mar-14
8685053	TETHER EQUIPPED CATHETER	Brian J Brown	1-Apr-14
8728147	LONGITUDINALLY FLEXIBLE EXPANDABLE STENT	Brian J Brown	20-May-14

ATTACHMENT B

MATERIALS CONSIDERED

EXHIBIT/PAPER No.	DESCRIPTION
EX1001	U.S. Patent No. 11,974,910 (“the ’910 patent”)
EX1002	’910 Patent Prosecution History
EX1003	Expert Declaration of Troy Thornton
EX1004	Resume of Troy Thornton
EX1005	U.S. Patent No. 8,734,374 B2 to Aklog et al. (“Aklog”)
EX1006	U.S. Patent Publication No. 2015/0173782 A1 to Garrison et al. (“Garrison”)
EX1007	WIPO Publication No. WO 2006/124307 A2 to Goff et al. (“Goff”)
EX1008	U.S. Patent Publication No. 2003/0116731 A1 to Hartley (“Hartley”)
EX1009	U.S. Patent No. 6,776,770 B2 to Trerotola (“Trerotola”)
EX1010	U.S. Patent Publication No. 2010/0042118 A1 to Garrison et al.
EX1011	U.S. Patent No. 8,535,283 B2 to Heaton et al. (“Heaton”)
EX1012	U.S. Patent Publication No. 2017/0043066 A1 to Laub (“Laub”)
EX1013	U.S. Patent Publication US 2003/0225379 A1 to Schaffer et al. (“Schaffer”)
EX1014	U.S. Patent No. 5,938,645 to Gordon (“Gordon”)
EX1015	U.S. Patent Publication No. 2014/0296868 A1 to Garrison et al.
EX1016	U.S. Patent No. 7,998,104 B2 to Chang (“Chang”)
EX1017	U.S. Patent No. 8,157,760 B2 to Criado et al. (“Criado”)
EX1018	U.S. Patent No. 6,481,439 B1 to Lewis et al.
EX1019	U.S. Patent No. 8,075,510 B2 to Aklog et al.

EXHIBIT/PAPER No.	DESCRIPTION
EX1020	WIPO Publication No. WO 2018/019829 A1 to Brady et al. (“Brady”)
EX1021	U.S. Patent Application No. 16/117,519 (the “519 application”)
EX1022	Expert Declaration of Dr. Aquilla S. Turk, III, DO
EX1023	Resume of Dr. Aquilla Turk, III, D.O.
EX1024	Shani, Jacob M.D., et al., Mechanical Manipulation of Thrombus: Coronary Thrombectomy, Intracoronary Clot Displacement, and Transcatheter Aspiration, 72 Am. J. Cardiol. 116G-118G (1993)
EX1025	Bose, A et al., The Penumbra System: A Mechanical Device for the Treatment of Acute Stroke due to Thromboembolism, 29 Am. J. Neuroradiol. 1409-1413 (Aug. 2008)
EX1026	Turk, Aquilla S. et al., Initial clinical experience with the ADAPT technique: A direct aspiration first pass technique for stroke thrombectomy, 6 J. NeuroIntervent. Surg. 231-237 (2014)
EX1027	Turk, Aquilla S. et al., ADAPT FAST study: a direct aspiration first pass technique for acute stroke thrombectomy, 6 J. NeuroIntervent. Surg. 260-264 (2014)
EX1028	April 24, 2024 Letter from Inari to Imperative Care
EX1029	Turk, Aquilla S. et al., Aspiration thrombectomy versus stent retriever thrombectomy as first-line approach for large vessel occlusion (COMPASS): a multicentre, randomized, open label, blinded outcome, non-inferiority trial, 393 Lancet 998-1008 (March 2019)
EX1030	Save, Jeffrey L., Time is Brain – Quantified, American Heart Association Journals, available at http://www.stokeaha.org (2005).
EX1031	U.S. Patent No. 9,980,813 B1 to Eller (“Eller”)
EX1032	US 2018/0064453 A1 (“Garrison II”)
EX1033	US 2005/0054995 A1 (“Barzell”)

EXHIBIT/PAPER No.	DESCRIPTION
EX1034	Decision Granting Institution of <i>Inter Partes</i> Review for U.S. Patent No. 11,697,011 (Paper 7) in <i>Imperative Care, Inc. v. Inari Medical, Inc.</i> , IPR2024-01157 (P.T.A.B. Jan. 23, 2025)
EX1035	Decision Granting Institution of <i>Inter Partes</i> Review for U.S. Patent No. 11,697,012 (Paper 6) in <i>Imperative Care, Inc. v. Inari Medical, Inc.</i> , IPR2025-00156 (P.T.A.B. Apr. 22, 2025)
EX1036	U.S. Patent No. 12,109,384 B2 to Merritt et al.
EX1037	Patent Owner’s Exhibit 2002 filed in <i>Imperative Care, Inc. v. Inari Medical, Inc.</i> , IPR2025-00289 (P.T.A.B.)
EX1038	Indigo Aspiration System-Penumbra Engine Pump and Canister, 510(k) No. K180105 (Mar. 8, 2018) (“Indigo Aspiration System”)
EX1039	AXS Universal Aspiration Set Brochure (2017)
EX1040	VacLok Negative Pressure Syringe Brochure
EX1041	O. Nikoubashman et al., Under Pressure: Comparison of Aspiration Techniques for Endovascular Mechanical Thrombectomy, 39 Am. J. Neuroradiol. 905-909 (May 2018) (“Nikoubashman”)
EX1042	Inari’s Supplemental Infringement Contentions (without claim charts) from <i>Inari Medical, Inc. v. Imperative Care, Inc.</i> , No. 24- cv-3117 (N.D. Cal.) (served February 7, 2025)
EX1043	Inari’s Notice of Motion and Motion for Leave to File Third Amended Complaint (Dkt. #88) in <i>Inari Medical, Inc. v. Imperative Care, Inc.</i> , 24-cv-03117-EKL (N.D. Cal.) (filed March 5, 2025)
EX1044	Case Management & Scheduling Order (Dkt. #54) in <i>Inari Medical, Inc. v. Imperative Care, Inc.</i> , 24-cv-03117-EKL (N.D. Cal.) (issued December 19, 2024)
EX1045	Decision Denying Institution of <i>Inter Partes</i> Review for U.S. Patent No. 11,744,691 (Paper 10) in <i>Imperative Care, Inc. v. Inari Medical, Inc.</i> , IPR2024-01257 (P.T.A.B. Feb. 7, 2025)
EX1046	U.S. Patent No. 7,984,730 B2 to Ziv et al.

EXHIBIT/PAPER No.	DESCRIPTION
EX1047	Imperative Care’s Opposition to Inari’s Motion for Leave to File Third Amended Complaint (Dkt. #98) in <i>Inari Medical, Inc. v. Imperative Care, Inc.</i> , 24-cv-03117-EKL (N.D. Cal.) (filed March 26, 2025)
EX1048	Imperative Care’s Notice of Motion and Motion to Stay Pending <i>Inter Partes</i> Review (Dkt. #100) in <i>Inari Medical, Inc. v. Imperative Care, Inc.</i> , 24-cv-03117-EKL (N.D. Cal.) (filed April 2, 2025)
EX1049	Ahmed Pasha et al., Successful Management of Acute Massive Pulmonary Embolism Using Angiovac Suction Catheter Technique in a Hemodynamically Unstable Patient, 15 <i>Cardiovasc. Revasc. Med.</i> 240-243 (2014)
EX1050	Certified File History of U.S. Patent Application 10/371,190 (Schaffer File History)
EX1051	Maureen Kohi, Catheter Directed Interventions for Acute Deep Vein Thrombosis, 6 <i>Cardiovasc. Diagn. Ther.</i> 599-611 (2016)
EX1052	Interview Summary from U.S. Patent Application No. 18/329,450 dated January 31, 2024
EX1053	Claim Construction Expert Report of Troy Thornton in <i>Inari Medical, Inc. v. Imperative Care, Inc.</i> , 24-cv-03117-EKL (N.D. Cal.)
EX1054	Decision Denying Patent Owner’s Request for Discretionary Denial (Paper 9) in <i>Imperative Care, Inc. v. Inari Medical, Inc.</i> , IPR202-500289 (P.T.A.B. June 12, 2025)
EX1055	Decision Referring the Petition to the Board (Paper 9) in <i>Imperative Care, Inc. v. Inari Medical, Inc.</i> , IPR2025-00728 (P.T.A.B. July 31, 2025)
EX1056	Order Denying Motion for Preliminary Injunction (Dkt. #136) in <i>Inari Medical, Inc. v. Imperative Care, Inc.</i> , 24-cv-03117-EKL (N.D. Cal.) (issued September 29, 2025)
EX1057	Joint Stipulation to Continue to Stay of Litigation Pending IPR Decisions and Vacate Upcoming Case Management Conference (Dkt. #139) in <i>Inari Medical, Inc. v. Imperative Care, Inc.</i> , 24-cv-03117-EKL (N.D. Cal.) (dated January 21, 2026)

EXHIBIT/PAPER No.	DESCRIPTION
EX1058	Order Granting Joint Stipulation to Continue the Stay of Litigation Pending IPR Decisions and Vacate Upcoming Case Management Conference (Dkt. #140) in <i>Inari Medical, Inc. v. Imperative Care, Inc.</i> , 24-cv-03117-EKL (N.D. Cal.) (issued January 21, 2026)
EX2001	Notice of Allowance from U.S. Patent Application No. 18/329,450
EX2002	U.S. Patent Application Publication No. 2018/0042623 to Batiste (“Batiste”)
EX2004	Mirza, M., Kummer, K., Touchette, J., McCarthy, R., Rai, A., Brouwer, P., & Gilvarry, M. (2024). Variability in Intracranial vessel Diameters and Considerations for Neurovascular Models: A Systematic Review and Meta-Analysis. <i>Stroke Vascular and Interventional Neurology</i> , 4(4). https://doi.org/10.1161/svin.123.001177
EX2005	Order Granting in Part Motion to Stay, <i>Inari Medical, Inc. v. Imperative Care, Inc.</i> , No. 5:24-cv-03117-EKL (N.D. Cal. Sept. 29, 2025), ECF No. 137
EX2006	Hearing Transcript, dated February 6, 2026
EX2007	<i>Reserved</i>
EX2008	Supplemental Declaration of Brian Brown
EX2009	Instructions for Use for Medtronic Bio-Bump™ BP-50, CBBP-50
EX2010	Instructions for Use for Maquet Getinge Group ROTAFLOW Centrifugal Pump
EX2011	40 Year Bio Pump Timeline
EX2012	OPERATING INSTRUCTIONS for the Pump Drive BVP-BP for centrifugal blood pump heads BP-50/BP-80 and SP-45
EX2013	Deposition Transcript of Troy L. Thornton (February 18, 2026)
EX2014	Deposition Transcript of Troy L. Thornton (February 19, 2026)
EX2015	Deposition Transcript of Aquilla S. Turk (February 25, 2026)
EX2016	Declaration of Dr. Christopher S. Morris
EX2017	Redacted version of Declaration of Brian Brown, Inari Medical,

	Inc. v. Imperative Care, Inc., No. 5:24-cv-03117-EKL (N.D. Cal. July 24, 2024), ECF No. 24-2
Paper 2	Petition for Inter Partes Review
Paper 15	Decision Granting Institution of <i>Inter Partes Review</i>