



US008535283B2

(12) **United States Patent**
Heaton et al.

(10) **Patent No.:** **US 8,535,283 B2**
(45) **Date of Patent:** **Sep. 17, 2013**

(54) **SYSTEM AND METHOD FOR APPLYING
REDUCED PRESSURE AT A TISSUE SITE**

2,969,057 A 1/1961 Simmons
3,066,672 A 12/1962 Crosby, Jr. et al.
3,084,691 A * 4/1963 Stoner 604/134

(75) Inventors: **Keith Patrick Heaton**, Poole (GB); **Ian James Hardman**, Bournemouth (GB)

(Continued)

FOREIGN PATENT DOCUMENTS

(73) Assignee: **KCI Licensing, Inc.**, San Antonio, TX (US)

AU 550575 A1 8/1982
AU 745271 4/1999

(Continued)

(*) Notice: Subject to any disclaimer, the term of this patent is extended or adjusted under 35 U.S.C. 154(b) by 276 days.

OTHER PUBLICATIONS

N.A. Bagautdinov, "Variant of External Vacuum Aspiration in the Treatment of Purulent Diseases of the Soft Tissues," *Current Problems in Modern Clinical Surgery: Interdepartmental Collection*, edited by V. Ye Volkov et al. (Chuvashia State University, Cheboksary, U.S.S.R. 1986);pp. 94-96.

(Continued)

(21) Appl. No.: **12/069,262**

(22) Filed: **Feb. 8, 2008**

Primary Examiner — Susan Su

Prior Publication Data

US 2008/0200905 A1 Aug. 21, 2008

Related U.S. Application Data

(60) Provisional application No. 60/900,555, filed on Feb. 9, 2007.

(51) **Int. Cl.**
A61M 27/00 (2006.01)

(52) **U.S. Cl.**
USPC **604/319**; 604/322; 604/543

(58) **Field of Classification Search**
USPC 604/313, 315, 316, 543, 540, 541, 604/328

See application file for complete search history.

(57) **ABSTRACT**

The illustrative embodiments described herein are directed to a manually-actuated pump and method for applying reduced pressure at a tissue site. The manually-actuated pump includes at least one variable volume chamber that is manually compressible into a plurality of positions. The manually-actuated pump includes a fixed volume chamber in communication with the at least one variable volume chamber. The manually-actuated pump also includes a filter housing having a hydrophobic filter that prevents liquid from entering the at least one variable volume chamber. The fixed volume chamber is coupled to the at least one variable volume chamber via the filter housing. The filter housing is located in between the at least one variable volume chamber and the fixed volume chamber. The fixed volume chamber has reduced pressure that is applied to the tissue site in response to a movement of the at least one variable volume chamber from a compressed position in the plurality of positions to an uncompressed position in the plurality of positions.

(56) **References Cited**

U.S. PATENT DOCUMENTS

1,355,846 A 10/1920 Rannells
2,547,758 A 4/1951 Keeling
2,632,443 A 3/1953 Leshner
2,682,873 A 7/1954 Evans et al.
2,910,763 A 11/1959 Lauterbach

24 Claims, 11 Drawing Sheets

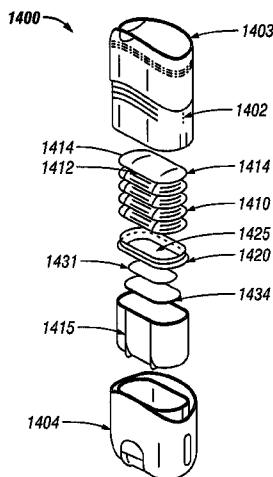

Imperative Care v. Inari Medical
U.S. Patent 11,974,910
Imperative Care Ex. 1011

(56)

References Cited

U.S. PATENT DOCUMENTS

3,367,332 A	2/1968	Groves	4,969,880 A	11/1990	Zamierowski
3,376,868 A	4/1968	Mondiadis	4,981,474 A	1/1991	Bopp et al.
3,520,300 A	7/1970	Flower Jr.	4,985,019 A	1/1991	Michelson
3,568,675 A	3/1971	Harvey	5,019,059 A *	5/1991	Goldberg et al. 604/317
3,648,692 A	3/1972	Wheeler	5,024,653 A *	6/1991	Kohnke 604/35
3,682,180 A	8/1972	McFarlane	5,037,397 A	8/1991	Kalt et al.
3,742,952 A	7/1973	Magers et al.	5,086,170 A	2/1992	Luheshi et al.
3,774,611 A	11/1973	Tussey et al.	5,092,858 A	3/1992	Benson et al.
3,779,243 A	12/1973	Tussey et al.	5,100,396 A	3/1992	Zamierowski
3,826,254 A	7/1974	Mellor	5,102,404 A	4/1992	Goldberg et al.
3,875,941 A *	4/1975	Adair 604/540	5,112,323 A	5/1992	Winkler et al.
4,080,970 A	3/1978	Miller	5,134,994 A	8/1992	Say
4,096,853 A	6/1978	Weigand	5,149,331 A	9/1992	Ferdman et al.
4,098,434 A	7/1978	Uhlig	5,167,613 A	12/1992	Karami et al.
4,132,332 A *	1/1979	Wassilieff 222/387	5,176,663 A	1/1993	Svedman et al.
4,139,004 A	2/1979	Gonzalez, Jr.	5,215,522 A	6/1993	Page et al.
4,141,361 A	2/1979	Snyder	5,226,877 A	7/1993	Epstein
4,165,748 A	8/1979	Johnson	5,232,453 A	8/1993	Plass et al.
4,184,510 A	1/1980	Murry et al.	5,261,893 A	11/1993	Zamierowski
4,233,969 A	11/1980	Lock et al.	5,278,100 A	1/1994	Doan et al.
4,245,630 A	1/1981	Lloyd et al.	5,279,550 A	1/1994	Habib et al.
4,256,109 A	3/1981	Nichols	5,298,015 A	3/1994	Komatsuzaki et al.
4,261,363 A	4/1981	Russo	5,304,129 A *	4/1994	Forgach 604/74
4,275,721 A	6/1981	Olson	5,318,548 A *	6/1994	Filshie 604/319
4,278,089 A	7/1981	Huck et al.	5,342,329 A	8/1994	Croquevielle
4,284,079 A	8/1981	Adair	5,342,376 A	8/1994	Ruff
4,297,995 A	11/1981	Golub	5,344,415 A	9/1994	DeBusk et al.
4,333,468 A	6/1982	Geist	5,358,494 A	10/1994	Svedman
4,372,297 A	2/1983	Perlin	5,437,622 A	8/1995	Carion
4,373,519 A	2/1983	Errede et al.	5,437,651 A	8/1995	Todd et al.
4,382,441 A	5/1983	Svedman	5,527,293 A	6/1996	Zamierowski
4,392,853 A	7/1983	Muto	5,542,939 A	8/1996	Onodera et al.
4,392,858 A	7/1983	George et al.	5,549,584 A	8/1996	Gross
4,419,097 A	12/1983	Rowland	5,554,011 A	9/1996	Bales et al.
4,460,354 A	7/1984	Weilbacher et al.	5,556,375 A	9/1996	Ewall
4,465,485 A	8/1984	Kashmer et al.	5,592,948 A *	1/1997	Gatten 600/576
4,475,909 A	10/1984	Eisenberg	5,607,388 A	3/1997	Ewall
4,480,638 A	11/1984	Schmid	5,636,643 A	6/1997	Argenta et al.
4,525,166 A	6/1985	Leclerc	5,645,081 A	7/1997	Argenta et al.
4,525,374 A	6/1985	Vaillancourt	5,645,540 A *	7/1997	Henniges et al. 604/320
4,529,402 A *	7/1985	Weilbacher et al. 604/133	5,714,696 A *	2/1998	Yeamans 73/863.84
4,540,412 A	9/1985	Van Overloop	5,718,355 A	2/1998	Garby et al.
4,543,100 A	9/1985	Brodsky	5,819,990 A	10/1998	Cimentepe et al.
4,548,202 A	10/1985	Duncan	5,827,246 A	10/1998	Bowen
4,551,139 A	11/1985	Plaas et al.	5,830,198 A *	11/1998	Henniges et al. 604/320
4,569,348 A	2/1986	Hasslinger	6,024,120 A	2/2000	Yam et al.
4,578,060 A *	3/1986	Huck et al. 604/133	6,024,731 A	2/2000	Seddon et al.
4,605,399 A	8/1986	Weston et al.	6,071,267 A	6/2000	Zamierowski
4,608,041 A	8/1986	Nielsen	6,135,116 A	10/2000	Vogel et al.
4,640,688 A	2/1987	Hauser	6,174,306 B1	1/2001	Fleischmann
4,642,088 A *	2/1987	Gunter 604/6.15	6,241,747 B1	6/2001	Ruff
4,643,719 A *	2/1987	Garth et al. 604/73	6,261,276 B1 *	7/2001	Reitsma 604/319
4,655,754 A	4/1987	Richmond et al.	6,287,316 B1	9/2001	Agarwal et al.
4,664,652 A	5/1987	Weilbacher	6,345,623 B1	2/2002	Heaton et al.
4,664,662 A	5/1987	Webster	6,485,007 B1	11/2002	Duelli
4,710,165 A	12/1987	McNeil et al.	6,488,643 B1	12/2002	Tumey et al.
4,733,659 A	3/1988	Edenbaum et al.	6,493,568 B1	12/2002	Bell et al.
4,743,232 A	5/1988	Kruger	6,553,998 B2	4/2003	Heaton et al.
4,758,220 A	7/1988	Sundblom et al.	6,626,891 B2	9/2003	Ohmstede
4,787,888 A	11/1988	Fox	6,648,862 B2	11/2003	Watson
4,798,583 A *	1/1989	Beck et al. 604/48	6,656,149 B2	12/2003	Ladd
4,826,494 A	5/1989	Richmond et al.	6,745,765 B2	6/2004	Kullik et al.
4,828,546 A	5/1989	McNeil et al.	6,814,079 B2	11/2004	Heaton et al.
4,838,883 A	6/1989	Matsuura	6,979,324 B2	12/2005	Bybordi et al.
4,840,187 A	6/1989	Brazier	7,004,915 B2	2/2006	Boynton et al.
4,863,449 A	9/1989	Therriault et al.	7,070,584 B2	7/2006	Johnson et al.
4,872,450 A	10/1989	Austad	7,625,362 B2 *	12/2009	Boehringer et al. 604/305
4,878,901 A	11/1989	Sachse	8,007,257 B2	8/2011	Heaton et al.
4,897,081 A	1/1990	Poirier et al.	2002/0065494 A1	5/2002	Lockwood et al.
4,903,726 A	2/1990	Martin et al.	2002/0077661 A1	6/2002	Saadat
4,906,233 A	3/1990	Moriuchi et al.	2002/0115951 A1	8/2002	Norstrem et al.
4,906,240 A	3/1990	Reed et al.	2002/0120185 A1	8/2002	Johnson
4,919,654 A	4/1990	Kalt et al.	2002/0143286 A1	10/2002	Tumey
4,941,882 A	7/1990	Ward et al.	2002/0198504 A1	12/2002	Risk, Jr. et al.
4,953,565 A	9/1990	Tachibana et al.	2003/0040687 A1 *	2/2003	Boynton et al. 601/6
			2004/0064132 A1	4/2004	Boehringer et al.
			2004/0243105 A1 *	12/2004	Swan et al. 604/543
			2005/0004534 A1	1/2005	Lockwood et al.
			2005/0070858 A1	3/2005	Lockwood et al.

2005/0087556 A1 4/2005 Signorini
 2005/0137539 A1 6/2005 Biggie et al.
 2005/0197639 A1 9/2005 Mombrinie
 2005/0261642 A1 11/2005 Weston
 2005/0261643 A1 11/2005 Bybordi et al.
 2006/0025727 A1 2/2006 Boehringer et al.
 2006/0216171 A1 9/2006 Hernandez
 2006/0229586 A1 10/2006 Faries, Jr.
 2007/0214692 A1 9/2007 Ferrara
 2008/0183156 A1* 7/2008 Yoo 604/541
 2008/0306456 A1* 12/2008 Riesinger 604/316

FOREIGN PATENT DOCUMENTS

AU 755496 2/2002
 CA 2005436 6/1990
 CN 2142728 Y 9/1993
 CN 1571682 A 1/2005
 CN 2745582 Y 12/2005
 CN 2829771 Y 10/2006
 DE 26 40 413 A1 3/1978
 DE 43 06 478 A1 9/1994
 DE 295 04 378 U1 10/1995
 EP 0100148 A1 2/1984
 EP 0117632 A2 9/1984
 EP 0161865 A2 11/1985
 EP 0358302 A2 3/1990
 EP 1018967 B1 8/2004
 GB 692578 6/1953
 GB 2 195 255 A 4/1988
 GB 2 197 789 A 6/1988
 GB 2 220 357 A 1/1990
 GB 2 235 877 A 3/1991
 GB 2 333 965 A 8/1999
 GB 2 329 127 B 8/2000
 JP S59-19144 2/1984
 JP 60050296 A 3/1985
 JP 4129536 4/1992
 SG 71559 4/2002
 WO WO 80/02182 10/1980
 WO WO 87/04626 8/1987
 WO WO 90/10424 9/1990
 WO WO 93/09727 5/1993
 WO WO 94/20041 9/1994
 WO WO 96/05873 2/1996
 WO WO 97/18007 5/1997
 WO WO 99/13793 3/1999
 WO WO 2006/114648 A2 11/2006
 WO WO 2007/013064 A1 2/2007
 WO WO 2007/133618 A2 11/2007
 WO WO 2009/135171 A2 11/2009

OTHER PUBLICATIONS

K.F. Jeter, T.E. Tintle, and M. Chariker, Managing Draining Wounds and Fistulae: "New and Established Methods," *Chronic Wound Care*, edited by D. Krasner (Health Management Publications, Inc., King of Prussia, PA 1990), pp. 240-246.
 G. Živadinović, V. Đukić, Ž. Maksimović, Đ. Radak, and P. Peška, "Vacuum Therapy in the Treatment of Peripheral Blood Vessels," *Timok Medical Journal* 11 (1986), pp. 161-164.
 F.E. Johnson, "An Improved Technique for Skin Graft Placement Using a Suction Drain," *Surgery, Gynecology, and Obstetrics* 159 (1984), pp. 584-585.
 A.A. Safronov, Dissertation Abstract, *Vacuum Therapy of Trophic Ulcers of the Lower Leg with Simultaneous Autoplasty of the Skin* (Central Scientific Research Institute of Traumatology and Orthopedics, Moscow, U.S.S.R. 1967).
 M. Schein, R. Saadia, J.R. Jamieson, and G.A.G. Decker, "The 'Sandwich Technique' in the Management of the Open Abdomen," *British Journal of Surgery* 73 (1986), pp. 369-370.
 D.E. Tribble, An Improved Sump Drain-Irrigation Device of Simple Construction, *Archives of Surgery* 105 (1972) pp. 511-513.
 M.J. Morykwas, L.C. Argenta, E.I. Shelton-Brown, and W. McGuirt, "Vacuum-Assisted Closure: A New Method for Wound Control and Treatment: Animal Studies and Basic Foundation," *Annals of Plastic Surgery* 38 (1997), pp. 553-562 (Morykwas I).

C.E. Tennants, "The Use of Hypermia in the Postoperative Treatment of Lesions of the Extremities and Thorax," *Journal of the American Medical Association* 64 (1915), pp. 1548-1549.
 Selections from W. Meyer and V. Schmieden, *Bier's Hyperemic Treatment in Surgery, Medicine, and the Specialties: A Manual of Its Practical Application*, (W.B. Saunders Co., Philadelphia, PA 1909), pp. 17-25, 44-64, 90-96, 167-170, and 210-211.
 NPD 1000 Negative Pressure Wound Therapy System, Kalypto Medical, pp. 1-4.
 Louis C. Argenta, MD and Michael J. Morykwas, PhD; "Vacuum-Assisted Closure: A New Method for Wound Control and Treatment: Clinical Experience"; *Annals of Plastic Surgery*, vol. 38, No. 6, Jun. 1997; pp. 563-576.
 Susan Mendez-Eastmen, RN; "When Wounds Won't Heal" RN Jan. 1998, vol. 61 (1); Medical Economics Company, Inc., Montvale, NJ, USA; pp. 20-24.
 James H. Blackburn, II, MD, et al; "Negative-Pressure Dressings as a Bolster for Skin Grafts"; *Annals of Plastic Surgery*, vol. 40, No. 5, May 1998, pp. 453-457.
 John Masters; "Reliable, Inexpensive and Simple Suction Dressings"; Letter to the Editor, *British Journal of Plastic Surgery*, 1998, vol. 51 (3), p. 267; Elsevier Science/the British Association of Plastic Surgeons, UK.
 S.E. Greer, et al "The Use of Subatmospheric Pressure Dressing Therapy to Close Lymphocutaneous Fistulas of the Groin" *British Journal of Plastic Surgery* (2000), 53, pp. 484-487.
 George V. Letsou, MD., et al; "Stimulation of Adenylate Cyclase Activity in Cultured Endothelial Cells Subjected to Cyclic Stretch"; *Journal of Cardiovascular Surgery*, 31, 1990, pp. 634-639.
 Orringer, Jay, et al; "Management of Wounds in Patients with Complex Enterocutaneous Fistulas"; *Surgery, Gynecology & Obstetrics*, Jul. 1987, vol. 165, pp. 79-80.
 International Search Report for PCT International Application PCT/GB95/01983; Nov. 23, 1995.
 PCT International Search Report for PCT International Application PCT/GB98/02713; Jan. 8, 1999.
 PCT Written Opinion, PCT International Application PCT/GB98/02713; Jun. 8, 1999.
 PCT International Examination and Search Report, PCT International Application PCT/GB96/02802; Jan. 15, 1998 & Apr. 29, 1997.
 PCT Written Opinion, PCT International Application PCT/GB96/02802; Sep. 3, 1997.
 Dattilo, Philip P., Jr., et al; "Medical Textiles: Application of an Absorbable Barbed Bi-directional Surgical Suture"; *Journal of Textile and Apparel, Technology and Management*, vol. 2, Issue 2, Spring 2002, pp. 1-5.
 Kostyuchenok, B.M., et al; "Vacuum Treatment in the Surgical Management of Purulent Wounds"; *Vestnik Khirurgi*, Sep. 1986, pp. 18-21 and 6 page English translation thereof.
 Davydov, Yu. A., et al; "Vacuum Therapy in the Treatment of Purulent Lactation Mastitis"; *Vestnik Khirurgi*, May 14, 1986, pp. 66-70, and 9 page English translation thereof.
 Yusupov, Yu. N., et al; "Active Wound Drainage", *Vestnik Khirurgi*, vol. 138, Issue 4, 1987, and 7 page English translation thereof.
 Davydov, Yu. A., et al; "Bacteriological and Cytological Assessment of Vacuum Therapy for Purulent Wounds"; *Vestnik Khirurgi*, Oct 1988, pp. 48-52, and 8 page English translation thereof.
 Davydov, Yu. A., et al; "Concepts for the Clinical-Biological Management of the Wound Process in the Treatment of Purulent Wounds by Means of Vacuum Therapy"; *Vestnik Khirurgi*, Jul. 7, 1980, pp. 132-136, and 8 page English translation thereof.
 Chariker, Mark E., M.D., et al; "Effective Management of incisional and cutaneous fistulae with closed suction wound drainage"; *Contemporary Surgery*, vol. 34, Jun. 1989, pp. 59-63.
 Egnell Minor, Instruction Book, First Edition, 300 7502, Feb. 1975, pp. 24.
 Egnell Minor: Addition to the Users Manual Concerning Overflow Protection—Concerns all Egnell Pumps, Feb. 3, 1983, pp. 2.
 Svedman, P.: "Irrigation Treatment of Leg Ulcers", *The Lancet*, Sep. 3, 1983, pp. 532-534.
 Chinn, Steven D. et al.: "Closed Wound Suction Drainage", *The Journal of Foot Surgery*, vol. 24, No. 1, 1985, pp. 76-81.

Arnljots, Björn et al.: "Irrigation Treatment in Split-Thickness Skin Grafting of Intractable Leg Ulcers", *Scand J. Plast Reconstr. Surg.*, No. 19, 1985, pp. 211-213.

Svedman, P.: "A Dressing Allowing Continuous Treatment of a Biosurface", *IRCS Medical Science: Biomedical Technology, Clinical Medicine, Surgery and Transplantation*, vol. 7, 1979, p. 221.

Svedman, P. et al.: "A Dressing System Providing Fluid Supply and Suction Drainage Used for Continuous or Intermittent Irrigation", *Annals of Plastic Surgery*, vol. 17, No. 2, Aug. 1986, pp. 125-133. International Search Report and Written Opinion date mailed Sep. 11, 2009; PCT Application No. PCT/US2009/042598.

V.A. Solovev et al., Guidelines, *The Method of Treatment of Immature External Fistulas in the Upper Gastrointestinal Tract*, editor-in-chief Prov. V.I. Parahonyak (S.M. Kirov Gorky State Medical Institute, Gorky, U.S.S.R. 1987) ("Solovev Guidelines").

V.A. Kuznetsov & N.a. Bagautdinov, "Vacuum and Vacuum-Sorption Treatment of Open Septic Wounds," in *II All-Union Conference on Wounds and Wound Infections: Presentation Abstracts*, edited by B.M. Kostyuchenok et al. (Moscow, U.S.S.R. Oct. 28-29, 1986) pp. 91-92 ("Bagautdinov II").

V.A. Solovev, Dissertation Abstract, *Treatment and Prevention of Suture Failures after Gastric Resection* (S.M. Kirov Gorky State Medical Institute, Gorky, U.S.S.R. 1988) ("Solovev Abstract").

PCT International Search Report for International Application No. PCT/US2008/001727 dated Jun. 30, 2008.

Restriction Requirement date mailed May 21, 2010 in U.S. Appl. No. 11/974,534.

Response to Restriction Requirement filed Jun. 21, 2010 in U.S. Appl. No. 11/974,534.

Partial Search Report date mailed Jul. 21, 2010 for PCT Application No. PCT/US2009/050126.

Non-Final Office Action date mailed Sep. 1, 2010 for U.S. Appl. No. 11/974,534.

Response filed Nov. 30, 2010 for U.S. Appl. No. 11/974,534.

Restriction Requirement date mailed Sep. 30, 2011 for U.S. Appl. No. 12/434,475.

Response filed Oct. 24, 2011 for U.S. Appl. No. 12/434,475.

Non-Final Office Action date mailed Dec. 5, 2011 for U.S. Appl. No. 12/434,579.

Non-Final Office Action date mailed Dec. 29, 2011 for U.S. Appl. No. 12/434,475.

Final Office Action date mailed Feb. 16, 2011 for U.S. Appl. No. 11/974,534.

Response filed Mar. 29, 2011 for U.S. Appl. No. 11/974,534.

Notice of Allowance date mailed Apr. 28, 2011 for U.S. Appl. No. 11/974,534.

Restriction Requirement date mailed Aug. 10, 2011 for U.S. Appl. No. 12/434,579.

Response filed Sep. 9, 2011 for U.S. Appl. No. 12/434,579.

* cited by examiner

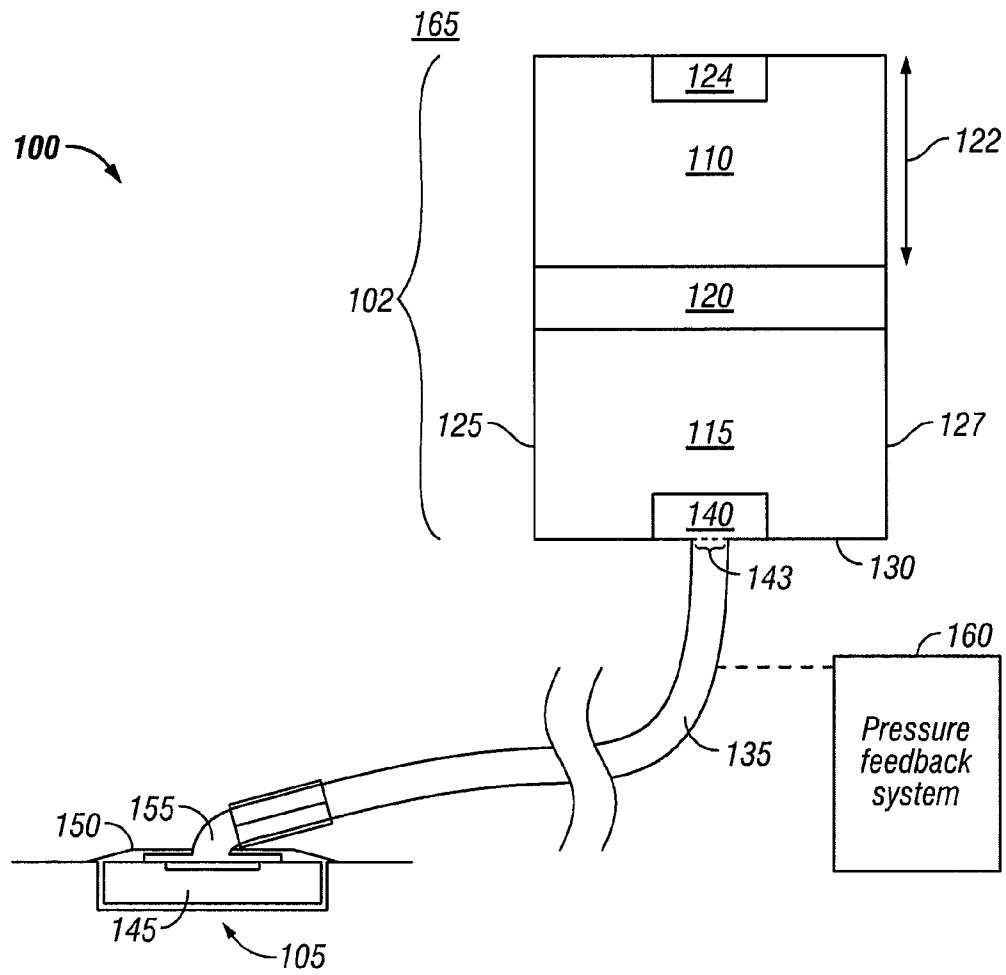

FIG. 1

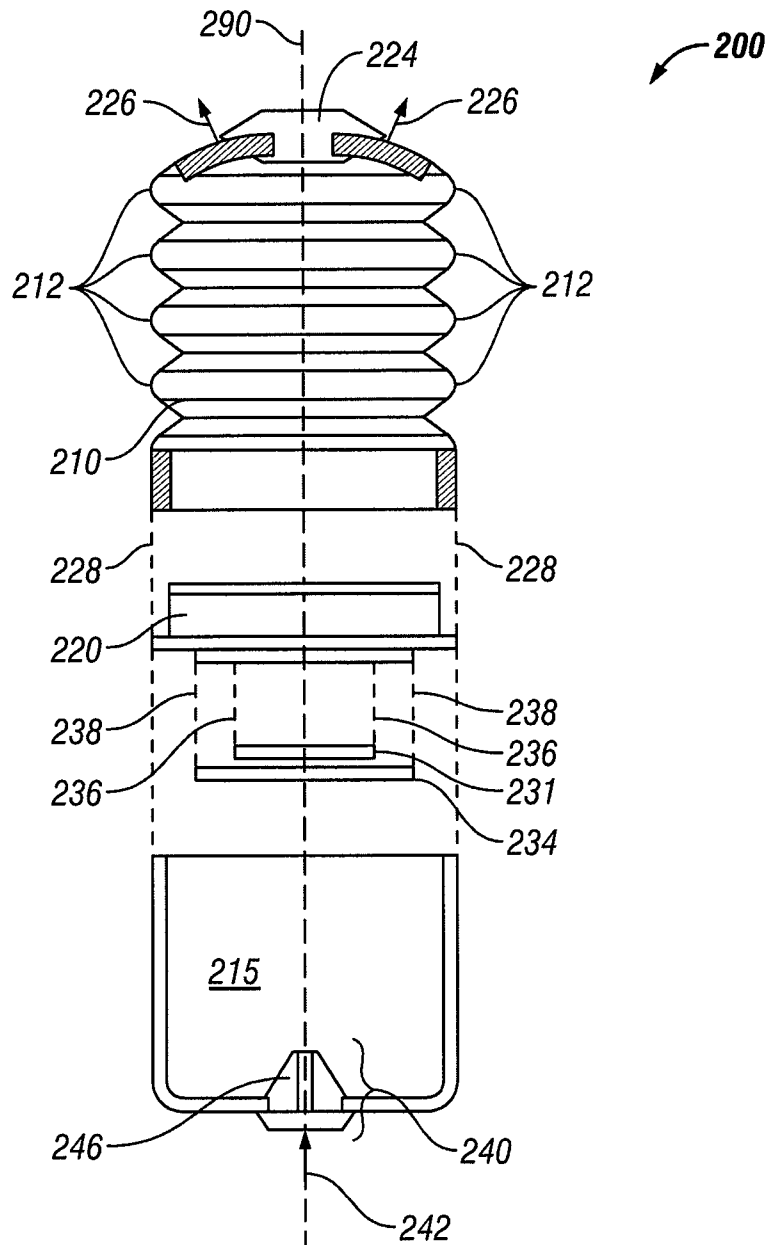

FIG. 2

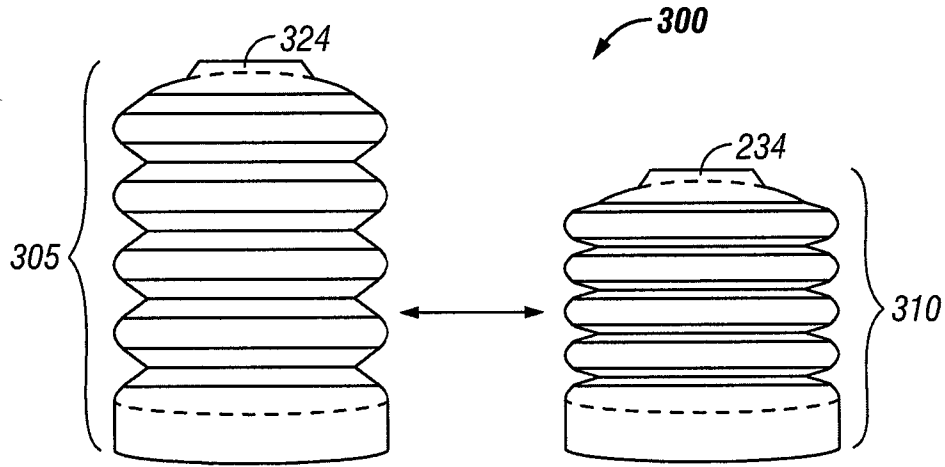

FIG. 3

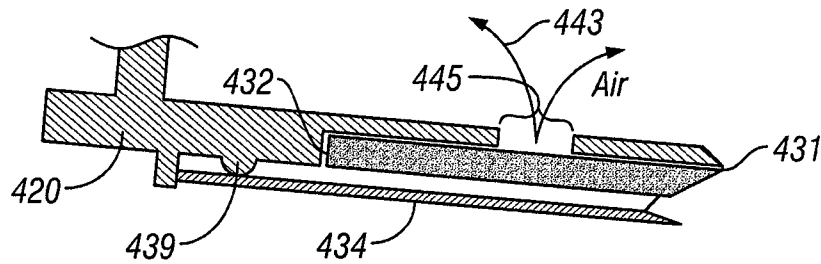

FIG. 4

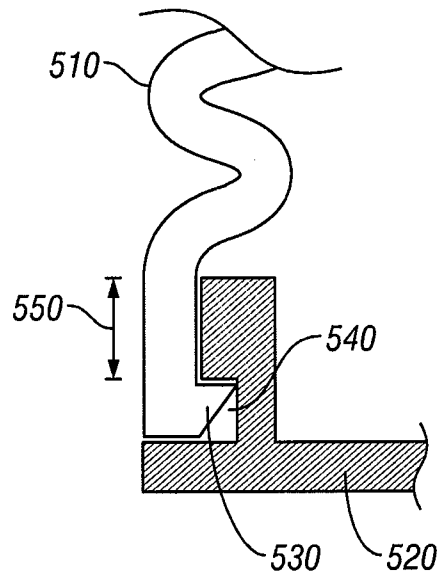

FIG. 5

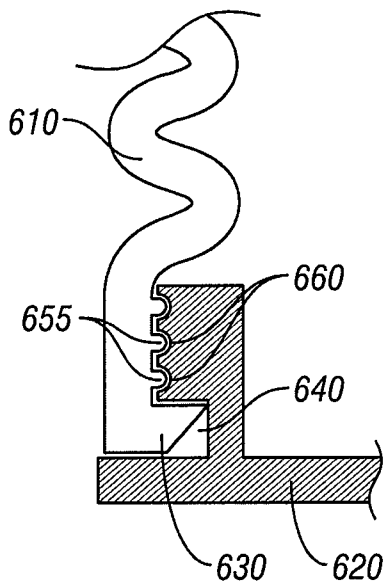

FIG. 6

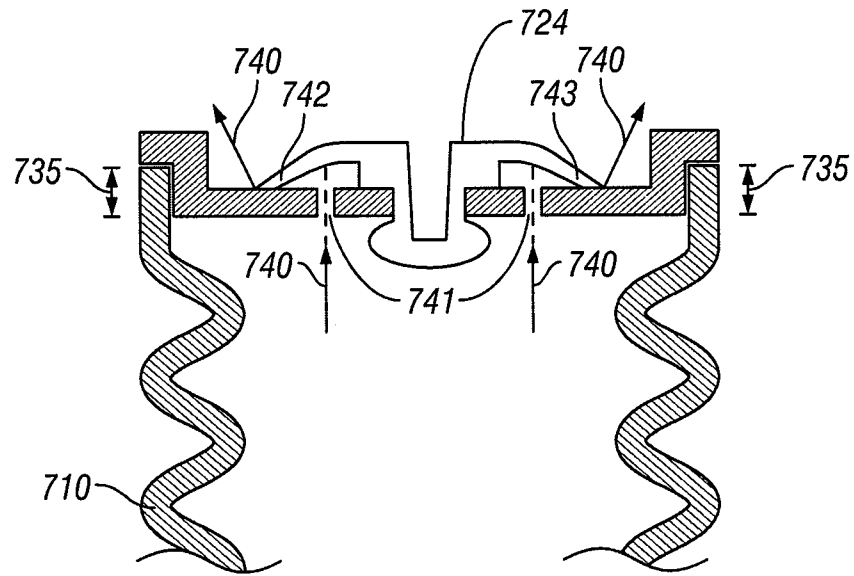

FIG. 7

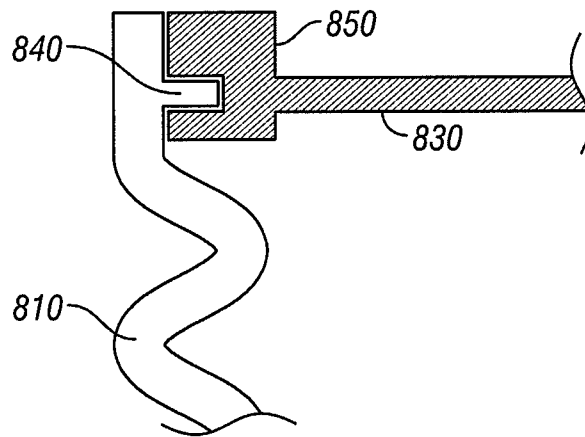

FIG. 8

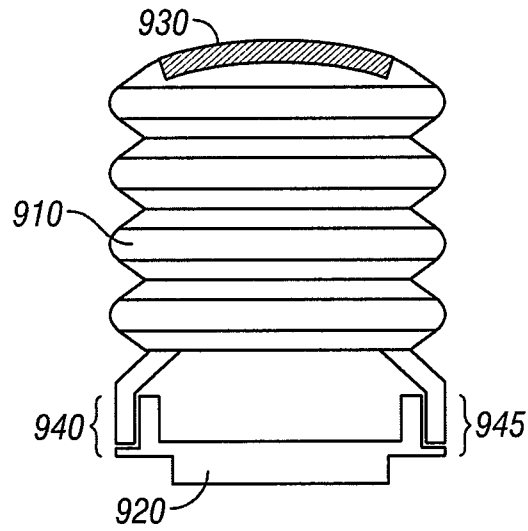

FIG. 9

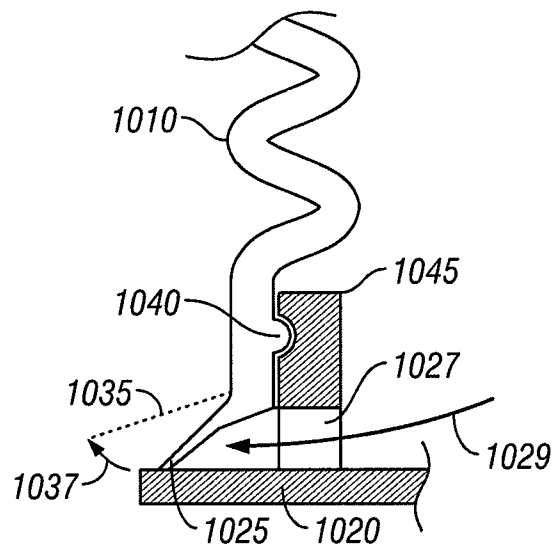

FIG. 10

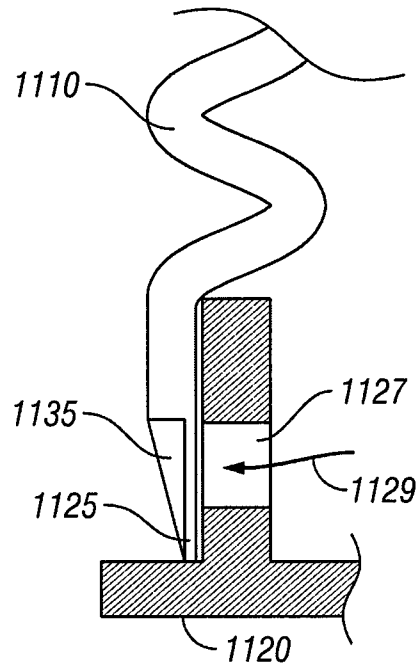

FIG. 11

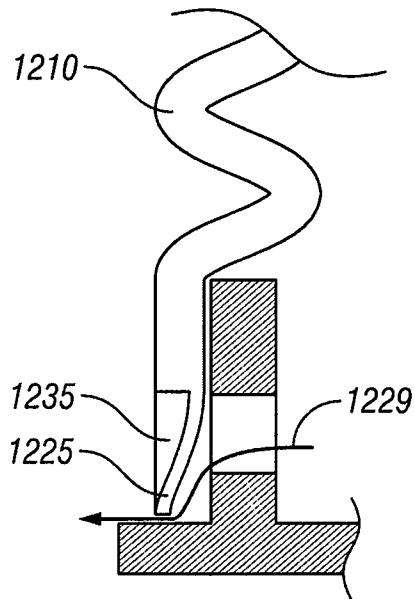

FIG. 12

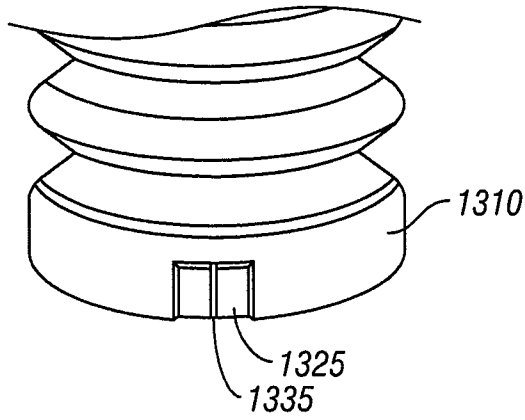

FIG. 13

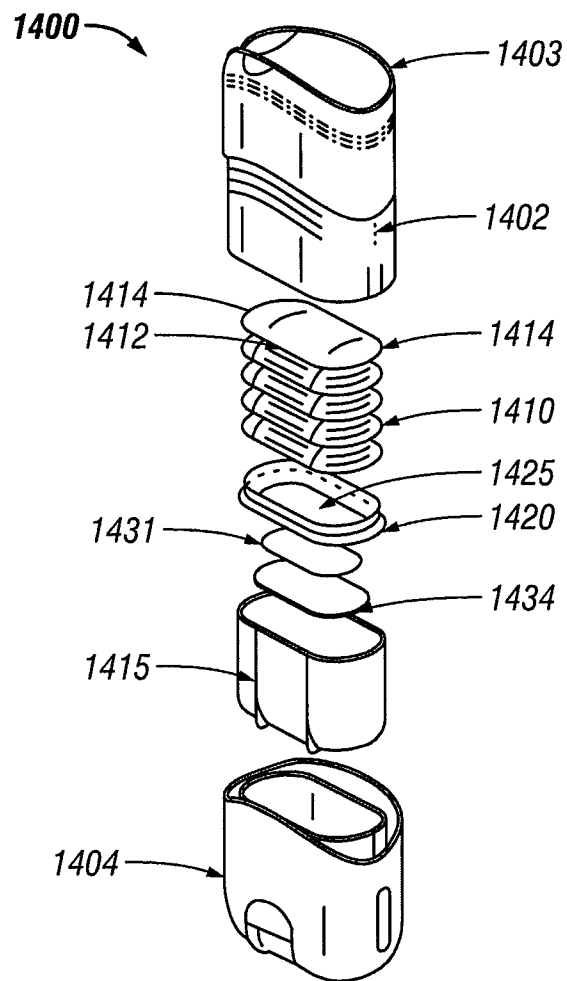

FIG. 14

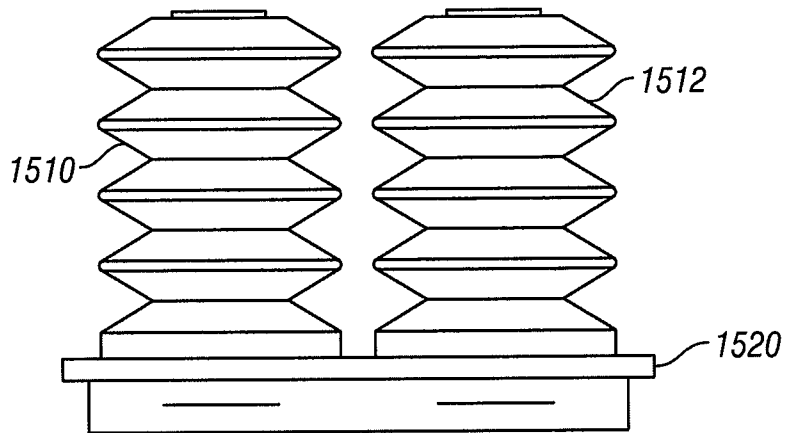

FIG. 15

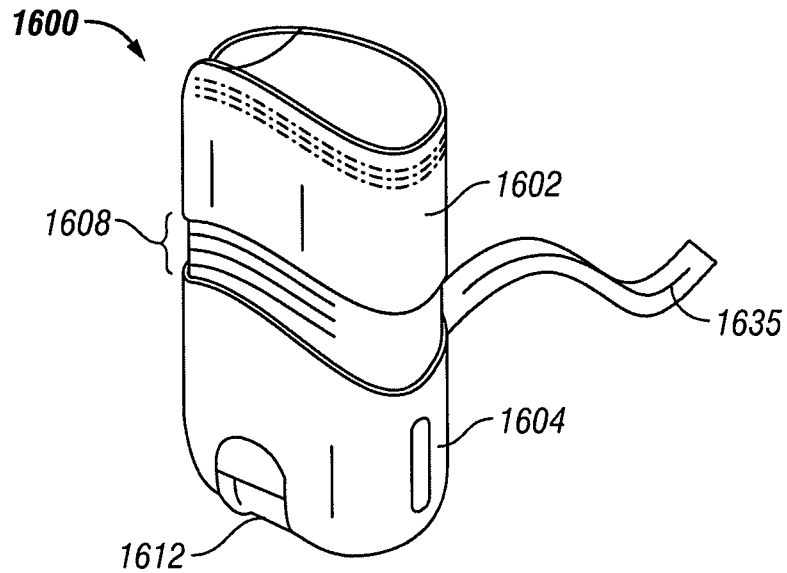

FIG. 16

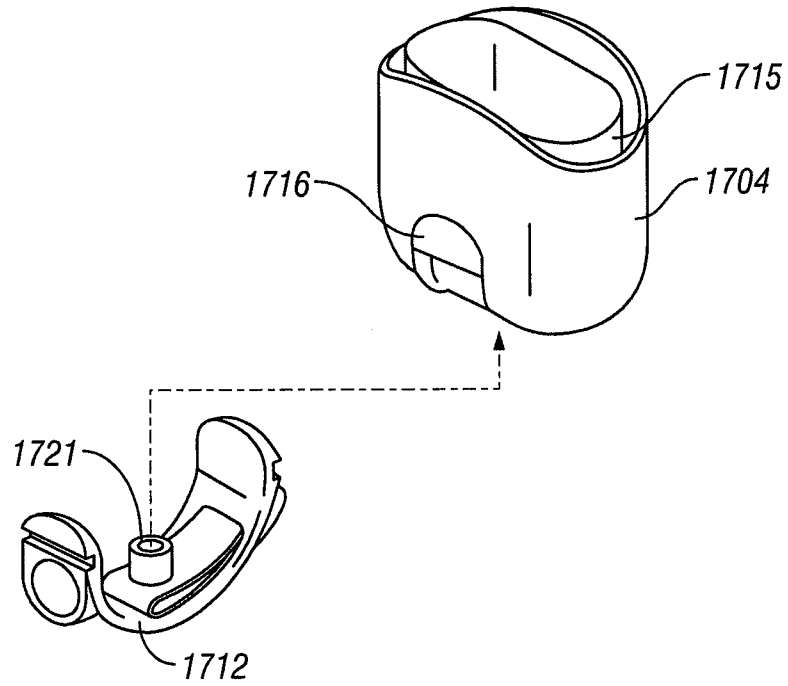

FIG. 17

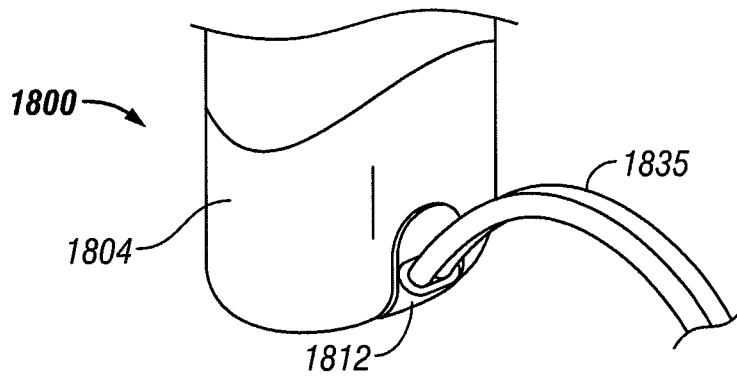

FIG. 18

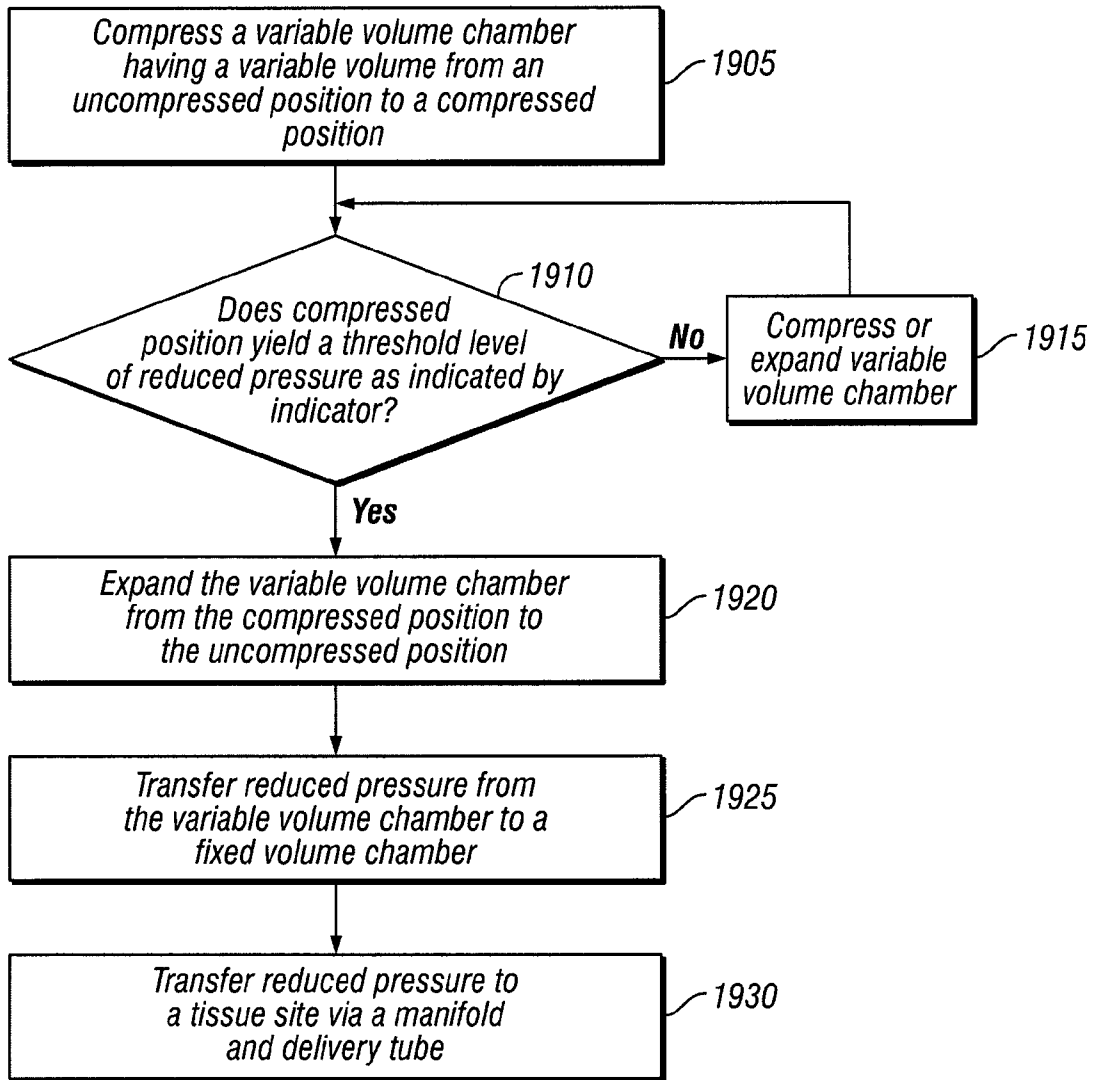

FIG. 19

1

SYSTEM AND METHOD FOR APPLYING REDUCED PRESSURE AT A TISSUE SITE

CROSS-REFERENCE TO RELATED APPLICATIONS

This application claims the benefit of the U.S. Provisional Application No. 60/900,555, filed Feb. 9, 2007, which is hereby incorporated by reference.

BACKGROUND OF THE INVENTION

1. Field of the Invention

The present invention relates generally to the field of tissue treatment, and more specifically to a system and method for applying reduced pressure at a tissue site.

2. Description of Related Art

Clinical studies and practice have shown that providing a reduced pressure in proximity to a tissue site augments and accelerates the growth of new tissue at the tissue site. The applications of this phenomenon are numerous, but application of reduced pressure has been particularly successful in treating wounds. The treatment of wounds using reduced pressure is sometimes referred to in the medical community as “negative pressure tissue treatment,” “reduced pressure therapy,” or “vacuum therapy.” This type of treatment provides a number of benefits, including faster healing, and increased formulation of granulation tissue.

Reduced pressure treatment systems are often applied to large, highly exudating wounds present on patients undergoing acute or chronic care, as well as other severe wounds that are not readily susceptible to healing without application of reduced pressure. Low-severity wounds that are smaller in volume and produce less exudate have generally been treated using advanced dressings instead of reduced pressure treatment.

Currently, the use of reduced pressure treatment is not considered a viable or affordable option for low-severity wounds due to the manpower required to monitor and change system components, the requirement for trained medical personnel overseeing treatment, and the high cost of treatment. For example, the complexity of current reduced pressure treatment systems precludes a person with little or no specialized knowledge from administering such treatment to oneself or others. The size and power consumption characteristics of current reduced pressure treatment systems also limit the mobility of both the treatment system and the person to whom the treatment is being applied. Also, the high cost of current reduced pressure treatment systems can preclude the accessibility of such treatment systems to some users. Current reduced pressure treatment systems are also typically non-disposable after each treatment, and require electrical components or other powered devices in order to generate the reduced pressure used in treatment.

While reduced pressure could be applied to low-volume and low-exudating wounds using traditional reduced pressure treatment systems, a need exists for a more simple system that allows reduced pressure treatment to be administered without specialized medical training. A need further exists for a system that uses little power and is compact, allowing a user of the system to remain mobile and participate in normal day-to-day activities. Finally, a system is needed that is inexpensive so that the system can economically be used by a single patient and then disposed of following the end of treatment for that patient.

BRIEF SUMMARY OF THE INVENTION

To alleviate the existing problems with reduced pressure treatment systems, the illustrative embodiments described

2

herein are directed to a manually-actuated pump and method for applying reduced pressure at a tissue site. The manually-actuated pump includes at least one variable volume chamber that is manually compressible into a plurality of positions.

5 The manually-actuated pump includes a fixed volume chamber in communication with the at least one variable volume chamber. The manually-actuated pump also includes a filter housing having a hydrophobic filter that prevents liquid from entering the at least one variable volume chamber. The fixed volume chamber is coupled to the at least one variable volume chamber via the filter housing. The filter housing is located in between the at least one variable volume chamber and the fixed volume chamber. The fixed volume chamber has reduced pressure that is applied to the tissue site in response to a movement of the at least one variable volume chamber from a compressed position in the plurality of positions to an uncompressed position in the plurality of positions.

The illustrative embodiments also provide a method for applying reduced pressure at a tissue site. The method compresses at least one variable volume chamber from an uncompressed position in a plurality of positions to a compressed position in the plurality of positions. The method, in response to expanding the at least one variable volume chamber from the compressed position to the uncompressed position, transfers reduced pressure from the at least one variable volume chamber to a fixed volume chamber via a filter housing having a hydrophobic filter that prevents liquid from entering the at least one variable volume chamber. The method applies the reduced pressure to the tissue site in response to transferring the reduced pressure from the at least one variable volume chamber to the fixed volume chamber. Other objects, features, and advantages of the invention will become apparent with reference to the drawings, detailed description, and claims that follow.

BRIEF DESCRIPTION OF THE DRAWINGS

FIG. 1 illustrates a block diagram of an apparatus for applying reduced pressure at a tissue site in accordance with an illustrative embodiment of the present invention;

FIG. 2 illustrates a perspective view of an apparatus for applying reduced pressure at a tissue site in accordance with an illustrative embodiment of the present invention;

FIG. 3 illustrates a perspective view of a compressible pump in an apparatus for applying reduced pressure at a tissue site in accordance with an illustrative embodiment of the present invention;

FIG. 4 illustrates a cross-sectional view of a filter housing in an apparatus for applying reduced pressure at a tissue site in accordance with an illustrative embodiment of the present invention;

FIG. 5 illustrates a cross-sectional view of an interlocking seal in an apparatus for applying reduced pressure at a tissue site in accordance with an illustrative embodiment of the present invention;

FIG. 6 illustrates a cross-sectional view of an interlocking seal in an apparatus for applying reduced pressure at a tissue site in accordance with an illustrative embodiment of the present invention;

FIG. 7 illustrates a cross-sectional view of an outlet valve in an apparatus for applying reduced pressure at a tissue site in accordance with an illustrative embodiment of the present invention;

FIG. 8 illustrates a cross-sectional view of a connection joint in an apparatus for applying reduced pressure at a tissue site in accordance with an illustrative embodiment of the present invention;

3

FIG. 9 illustrates a perspective view of outlet valves on a compressible pump in an apparatus for applying reduced pressure at a tissue site in accordance with an illustrative embodiment of the present invention;

FIG. 10 illustrates a cross-sectional view of an outlet valve in an apparatus for applying reduced pressure at a tissue site in accordance with an illustrative embodiment of the present invention;

FIG. 11 illustrates a cross-sectional view of an outlet valve in an apparatus for applying reduced pressure at a tissue site in accordance with an illustrative embodiment of the present invention;

FIG. 12 illustrates a cross-sectional view of an outlet valve in an apparatus for applying reduced pressure at a tissue site in accordance with an illustrative embodiment of the present invention;

FIG. 13 illustrates a perspective view of an outlet valve in an apparatus for applying reduced pressure at a tissue site in accordance with an illustrative embodiment of the present invention;

FIG. 14 illustrates a perspective view of an apparatus for applying reduced pressure at a tissue site in accordance with an illustrative embodiment of the present invention;

FIG. 15 illustrates a perspective view of two compressible pumps in an apparatus for applying reduced pressure at a tissue site in accordance with an illustrative embodiment of the present invention;

FIG. 16 illustrates a perspective view of an apparatus for applying reduced pressure at a tissue site in accordance with an illustrative embodiment of the present invention;

FIG. 17 illustrates a perspective view of a casing in an apparatus for applying reduced pressure at a tissue site in accordance with an illustrative embodiment of the present invention;

FIG. 18 illustrates a perspective view of a casing in an apparatus for applying reduced pressure at a tissue site in accordance with an illustrative embodiment of the present invention;

FIG. 19 illustrates a flowchart illustrating a process for applying reduced pressure at a tissue site in accordance with an illustrative embodiment of the present invention.

DETAILED DESCRIPTION OF THE ILLUSTRATIVE EMBODIMENTS

In the following detailed description of the illustrative embodiments, reference is made to the accompanying drawings that form a part hereof. These embodiments are described in sufficient detail to enable those skilled in the art to practice the invention, and it is understood that other embodiments may be utilized and that logical structural, mechanical, electrical, and chemical changes may be made without departing from the spirit or scope of the invention. To avoid detail not necessary to enable those skilled in the art to practice the embodiments described herein, the description may omit certain information known to those skilled in the art. The following detailed description is, therefore, not to be taken in a limiting sense, and the scope of the present invention is defined only by the appended claims.

The illustrative embodiments described herein provide an apparatus and method for applying reduced pressure at a tissue site. Reduced pressure generally refers to a pressure less than the ambient pressure at a tissue site that is being subjected to treatment. In most cases, this reduced pressure will be less than the atmospheric pressure of the location at which the patient is located. Although the terms “vacuum” and “negative pressure” may be used to describe the pressure

4

applied to the tissue site, the actual pressure applied to the tissue site may be significantly less than the pressure normally associated with a complete vacuum. Consistent with this nomenclature, an increase in reduced pressure or vacuum pressure refers to a relative reduction of absolute pressure, while a decrease in reduced pressure or vacuum pressure refers to a relative increase of absolute pressure.

The manually-actuated pump includes at least one variable volume chamber that is manually compressible into a plurality of positions. The manually-actuated pump includes a fixed volume chamber in communication with the at least one variable volume chamber. The manually-actuated pump also includes a filter housing having a hydrophobic filter that prevents liquid from entering the at least one variable volume chamber. The fixed volume chamber is coupled to the at least one variable volume chamber via the filter housing. As used herein, the term “coupled” includes coupling via a separate object. For example, the fixed volume chamber may be coupled to the at least one variable volume chamber if both the fixed volume chamber and the at least one variable volume chamber are coupled to a third object, such as a filter housing. The term “coupled” also includes “directly coupled,” in which case the two objects touch each other in some way. The term “coupled” also encompasses two or more components that are continuous with one another by virtue of each of the components being formed from the same piece of material.

The filter housing is located in between the at least one variable volume chamber and the fixed volume chamber. The fixed volume chamber has reduced pressure that is applied to the tissue site in response to a movement of the at least one variable volume chamber from a compressed position in the plurality of positions to an uncompressed position in the plurality of positions.

Turning now to FIG. 1, reduced pressure treatment system 100, which applies reduced pressure to a tissue site 105, is shown according to an illustrative embodiment. Tissue site 105 may be the bodily tissue of any human, animal, or other organism, including bone tissue, adipose tissue, muscle tissue, dermal tissue, vascular tissue, connective tissue, cartilage, tendons, ligaments, or any other tissue. While tissue site 105 may include a wound, diseased tissue, or defective tissue, the tissue site may also be healthy tissue that is not wounded, diseased, or defective. The application of reduced pressure to tissue site 105 may be used to promote the drainage of exudate and other liquids from tissue site 105, as well as stimulate the growth of additional tissue. In the case in which tissue site 100 is a wound site, the growth of granulation tissue and removal of exudates and bacteria promotes healing of the wound. The application of reduced pressure to non-wounded or non-defective tissue, including healthy tissue, may be used to promote the growth of tissue that may be harvested and transplanted to another tissue location.

Reduced pressure treatment system 100 includes pump 102. Pump 102 includes a variable volume chamber 110 and fixed volume chamber 115, which are coupled to one another via filter housing 120. Variable volume chamber 110 has a variable volume that is affected by the compression of compressible pump along axis 122. Variable volume chamber 110 may also be compressed along other axes.

Variable volume chamber 110 may be manually-actuated. That is, the compression of variable volume chamber 110 may be performed by any living organism. For example, variable volume chamber 110 may be manually pushed, squeezed, or otherwise compressed by a human hand, finger, or other limb. Variable volume chamber 110 may be any type

5

of manually-actuated chamber. For example, variable volume chamber 110 may be a compressible bellows have corrugated side walls.

In one embodiment, variable volume chamber 110 is compressible into a plurality of positions, each of which may define a different volume for variable volume chamber 110. For example, variable volume chamber 110 may have a fully uncompressed position at which variable volume chamber 110 has the greatest volume. In this example, variable volume chamber 110 may also have a fully compressed position at which variable volume chamber 110 has the smallest volume. Variable volume chamber 110 may also have any position between the fully uncompressed position and the fully compressed position. Thus, the uncompressed and compressed positions may be any positions at or between the fully uncompressed position and the fully compressed position in which the uncompressed position has a greater volume than the compressed position.

Variable volume chamber 110 includes outlet valve 124. Outlet valve 124 permits the passage of gas, such as air, out of variable volume chamber 110. Outlet valve 124 also prevents gas from entering variable volume chamber 110. This, when the volume of variable volume chamber 110 is reduced due to the compression of compressible pump from an uncompressed position to a compressed position, gas is forced out of variable volume chamber 110. Outlet valve 124 may be any type of valve capable of permitting the passage of gas out of variable volume chamber 110 while preventing the passage of gas into variable volume chamber 110. A non-limiting example of valve 124 is an umbrella valve, duckbill valve, ball valve, diaphragm valve, and any type of one-way valve.

Although FIG. 1 shows variable volume chamber 110 as having a single outlet valve 124, variable volume chamber 110 may have any number of outlet valves. Also, although FIG. 1 shows outlet valve 124 at the end portion of variable volume chamber 110, outlet valve 124 may be located on any portion of variable volume chamber 110, such as the side walls of variable volume chamber 110. In one embodiment, outlet valve 124 is located at an end of variable volume chamber 110 that is opposite of the end at which filter housing 120 is located. Additional details regarding outlet valve 124 will be provided in FIGS. 2, 7, and 9-13 below.

Pump 102 also includes fixed volume chamber 115. Fixed volume chamber 115 is capable of containing any fluid, such as gases and liquids, as well as fluids that contain solids. For example, fixed volume chamber 115 may contain exudates from tissue site 105. In one example, fixed volume chamber 115 has a substantially fixed volume. Fixed volume chamber 115 may be made of any material capable of providing fixed volume chamber 115 with a substantially fixed volume, including metal, plastic, or hardened rubber.

Fixed volume chamber 115 includes side walls 125 and 127, which are coupled to end wall 130. Side walls 125 and 127 may be contiguously formed with an end wall 130 such that no joint exists between side walls 125 and 127 and end wall 130. In addition, side walls 125 and 127 may be welded, screwed, glued, bolted, air-lock sealed, or snapped onto end wall 130.

Fixed volume chamber 115 is coupled to variable volume chamber 110 by filter housing 120. Fixed volume chamber 115 and variable volume chamber 110 may be coupled to filter housing 120 in a variety of ways. For example, fixed volume chamber 115 or variable volume chamber 110 may be welded, screwed, glued, bolted, air-lock sealed, or snapped onto filter housing 120. Fixed volume chamber 115 or variable volume chamber 110 may also be part of the same material as filter housing 120, thereby eliminating the need

6

for joints or seals between fixed volume chamber 115 and filter housing 120. In another example, variable volume chamber 110 may be sealed to filter housing 120 using an interlocking seal. Additional details regarding the coupling of filter housing 120 with fixed volume chamber 115 or variable volume chamber 110 are described below in FIGS. 2, 5, 6, 10-13, and 14.

Filter housing 120 is capable of including one or more filters. In one embodiment, filter housing 120 includes a hydrophobic filter that prevents liquid from entering variable volume chamber 110 from fixed volume chamber 115. However, as described below, the hydrophobic filter permits the passage of air such that reduced pressure may be transferred from variable volume chamber 110 to fixed volume chamber 115. Filter housing 120 may also include an odor filter that restrains or prevents the transmission of odor from fixed volume chamber 115 to variable volume chamber 110. Additional details regarding the hydrophobic filter and odor filter will be provided in FIGS. 2, 4, and 14 below.

Fixed volume chamber 115 is coupled to delivery tube 130 via inlet valve 140. Inlet valve 140 is located at inlet point 143. Inlet valve 140 permits the passage of fluid, such as exudate, into fixed volume chamber 115 at inlet point 143. Inlet valve 140 also restrains the passage of fluid out of fixed volume chamber 115 at inlet point 143. Inlet valve 140 may be any type of valve, such as an umbrella valve, duck bill valve, or a combination thereof.

Inlet valve 124 may be located at the center of end wall 130. Although FIG. 1 shows fixed volume chamber 115 as having a single inlet valve 140, fixed volume chamber 115 may have any number of inlet valves. Also, although FIG. 1 shows inlet valve 140 at end wall 130 of fixed volume chamber 115, outlet valve 140 may be located on any portion of fixed volume chamber 115, such as side walls 125 and 127 of fixed volume chamber 115. Additional details regarding inlet valve 140 will be provided in FIGS. 2 and 17 below.

Delivery tube 140 is any tube through which a fluid may flow. Delivery tube 135 may be made from any material, and may include one or more paths or lumens through which fluid may flow. For example, delivery tube 135 may include two lumens. In this example, one lumen may be used for the passage of exudate from tissue site 105 to fixed volume chamber 115. The other lumen may be used to deliver fluids, such as air, antibacterial agents, antiviral agents, cell-growth promotion agents, irrigation fluids, or other chemically active agents, to tissue site 105. The fluid source from which these deliverable fluids originate is not shown in FIG. 1.

Delivery tube 135 may be fixedly attached to fixed volume chamber 115 at inlet point 143. Also, delivery tube 135 may be detachable from fixed volume chamber 115 at inlet point 143. For example, delivery tube 135 may be snapped onto fixed volume chamber 115. Additional details regarding the coupling the delivery tube 135 to fixed volume chamber 115 will be provided in FIGS. 2 and 16-18 below.

The opposite end of delivery tube 135 is coupled to a manifold 145. Manifold 145 may be a biocompatible, porous material that is capable of being placed in contact with tissue site 105 and distributing reduced pressure to the tissue site 105. Manifold 145 may be made from foam, gauze, felted mat, or any other material suited to a particular biological application. Manifold 145 may include a plurality of flow channels or pathways to facilitate distribution of reduced pressure or fluids to or from the tissue site.

In one embodiment, manifold 145 is a porous foam and includes a plurality of interconnected cells or pores that act as flow channels. The porous foam may be a polyurethane, open-cell, reticulated foam such as GranuFoam manufac-

tured by Kinetic Concepts, Inc. of San Antonio, Tex. If an open-cell foam is used, the porosity may vary, but is preferably about 400 to 600 microns. The flow channels allow fluid communication throughout the portion of manifold 145 having open cells. The cells and flow channels may be uniform in shape and size, or may include patterned or random variations in shape and size. Variations in shape and size of the cells of manifold result in variations in the flow channels, and such characteristics may be used to alter the flow characteristics of fluid through manifold 145.

In one embodiment, manifold 145 may further include portions that include "closed cells." These closed-cell portions of manifold 145 contain a plurality of cells, the majority of which are not fluidly connected to adjacent cells. Closed-cell portions may be selectively disposed in manifold 145 to prevent transmission of fluids through perimeter surfaces of manifold 145.

Manifold 145 may also be constructed from bioresorbable materials that do not have to be removed from a patient's body following use of reduced pressure treatment system 100. Suitable bioresorbable materials may include, without limitation, a polymeric blend of polylactic acid (PLA) and polyglycolic acid (PGA). The polymeric blend may also include without limitation polycarbonates, polyfumarates, and caprolactones. Manifold 145 may further serve as a scaffold for new cell-growth, or a scaffold material may be used in conjunction with manifold 145 to promote cell-growth. A scaffold is a substance or structure used to enhance or promote the growth of cells or formation of tissue, such as a three-dimensional porous structure that provides a template for cell growth. Illustrative examples of scaffold materials include calcium phosphate, collagen, PLA/PGA, coral hydroxy apatites, carbonates, or processed allograft materials. In one example, the scaffold material has a high void-fraction (i.e. a high content of air).

Manifold 145 may be secured to tissue site 105 using sealing member 150. Sealing member 150 may be a cover that is used to secure manifold 145 at tissue site 105. While sealing member 150 may be impermeable or semi-permeable, in one example sealing member 150 is capable of maintaining a reduced pressure at tissue site 105 after installation of the sealing member 150 over manifold 145. Sealing member 150 may be a flexible drape or film made from a silicone based compound, acrylic, hydrogel or hydrogel-forming material, or any other biocompatible material that includes the impermeability or permeability characteristics desired for tissue site 105.

In one embodiment, sealing member 150 is configured to provide a sealed connection with the tissue surrounding manifold 145 and tissue site 105. The sealed connection may be provided by an adhesive positioned along a perimeter of sealing member 150 or on any portion of sealing member 150 to secure sealing member 150 to manifold 145 or the tissue surrounding tissue site 105. The adhesive may be pre-positioned on sealing member 150 or may be sprayed or otherwise applied to sealing member 150 immediately prior to installing sealing member 150.

In some cases, sealing member 150 may not be required to seal tissue site 105. For example, tissue site 105 may be capable of being "self-sealed" to maintain reduced pressure. In the case of subcutaneous and deep tissue wounds, cavities, and fistulas, maintenance of reduced pressure at tissue site 105 may be possible without the use of sealing member 150. Since tissue often encases or surrounds these types of tissue sites, the tissue surrounding the tissue site acts effectively as a sealing member.

In one embodiment, delivery tube 135 is coupled to manifold 145 via connection member 155. Connection member 155 permits the passage of fluid from manifold 145 to delivery tube 135, and vice versa. For example, exudates collected from tissue site 105 using manifold 145 may enter delivery tube 135 via connection member 155. In another embodiment, reduced pressure treatment system 100 does not include connection member 155. In this embodiment, delivery tube 135 may be inserted directly into sealing member 150 such that an end of delivery tube 135 is adjacent to manifold 145.

Reduced pressure treatment system 100 may also include pressure feedback system 160. Pressure feedback system 160 may be operably associated with the other components of reduced pressure treatment system 100 to provide information to a user of reduced pressure treatment system 100 that indicates a relative or absolute amount of pressure that is being delivered to tissue site 105. Pressure feedback system 160 allows a user to accurately track the amount of reduced pressure that is being generated by reduced pressure treatment system 100. Non-limiting examples of pressure feedback systems include pop valves that activate when the reduced pressure rises above a selected value, low power electronic indicators powered by miniature cells, dial indicators that indicate specific pressure values that are being applied to the tissue site, deflection pop valves, polymers with various deflection characteristics, and films that move relative to one another to produce visual identifiers indicating the relative or absolute pressure values being generated by reduced pressure treatment system 100. An example of a film-based system may include a yellow film anchored to a first part of pump 102 that is capable of movement relative to a blue film anchored to a second part. When the first and second parts are moved relative to one another to apply a reduced pressure, the yellow and blue films overlap to create a green indicator. As the pressure increases and the films move away from one another, the loss of the green color indicates that the pressure has increased (i.e. more reduced pressure needs to be applied).

Also, although pressure feedback system 160 is shown as separate from the other components of reduced pressure treatment system 100, pressure feedback system 160 may form an integral part of any of the components of reduced pressure treatment system 100. Additional details regarding pressure feedback system 160 will be described in FIGS. 14 and 16 below. In addition to the above-mentioned components and systems, reduced pressure treatment system 100 may include valves, regulators, switches, and other electrical, mechanical, and fluid components to facilitate administration of reduced pressure treatment to tissue site 105.

A desiccant or absorptive material may be disposed within fixed volume chamber 115 to trap or control fluid once the fluid has been collected. In the absence of fixed volume chamber 115, a method for controlling exudate and other fluids may be employed in which the fluids, especially those that are water soluble, are allowed to evaporate from manifold 145.

In one embodiment, variable volume chamber 110 is moved from an uncompressed position to a compressed position, thereby decreasing the volume of variable volume chamber 110. As a result, gas is expelled from variable volume chamber 110 through outlet valve 124. Because gas cannot enter variable volume chamber 110 via outlet valve 124, gas cannot enter variable volume chamber 110 from surrounding space 165. Thus, as variable volume chamber 110 expands from the compressed position to the uncompressed position, gas is transferred from fixed volume chamber 115 to variable volume chamber 110. The movement of variable volume

9

chamber **110** from a compressed position to an uncompressed position may be caused by any expansion force. In an illustrative example in which the side walls of variable volume chamber **110** are corrugated side walls, the expansion force may be caused by the tendency of the corrugations in the corrugated side walls to move away from one another and thereby return variable volume chamber **110** to the uncompressed position. The expansion force may also be caused by an independent biasing member, such as a spring or foam component, that is located within or without variable volume chamber **110**. In another example, the resiliency of non-corrugated side walls of variable volume chamber **110** may be used to move variable volume chamber **110** to an uncompressed position.

Liquid, such as exudate, is prevented from being transferred from fixed volume chamber **115** to variable volume chamber **110** by a filter, such as a hydrophobic filter, in filter housing **120**. Because fixed volume chamber **115** is sealed from surrounding space **165**, a reduced pressure is generated in fixed volume chamber **115** as variable volume chamber **110** expands from the compressed position to the uncompressed position. This reduced pressure is then transferred to tissue site **105** via delivery tube **135** and manifold **145**. This reduced pressure may be maintained at tissue site **105** using sealing member **150**.

This process of moving variable volume chamber **110** from an uncompressed to a compressed position, and vice versa, in order to achieve a reduced pressure at tissue site **105** may be repeated. In particular, variable volume chamber **110** may undergo multiple compression/expansion cycles until fixed volume chamber **115** is filled with liquid, such as exudate, from tissue site **105**. The multi-chamber configuration of pump **102**, which includes variable volume chamber **110** and fixed volume chamber **115**, permits compressible pump to be compressed regardless of the amount of liquid in fixed volume chamber **115**. As a result, the desired pressure may be achieved during the compression/expansion cycles regardless of the amount of liquid in fixed volume chamber **115**.

Turning now to FIG. 2, pump **200**, which is a non-limiting example of pump **102** in FIG. 1, is shown in accordance with an illustrative embodiment. Pump **200** may be used as a substitute for pump **102** in FIG. 1.

Pump **200** includes compressible bellows **210**. Compressible bellows **210** is a non-limiting example of variable volume chamber **110** in FIG. 1. Compressible bellows **210** may be moved into a plurality of positions, such as an uncompressed position and a compressed position. Compressible bellows **210** is formed from corrugated side walls with corrugations **212**. Corrugations **212** may move toward and away from one another, resulting in a compression and expansion of compressible bellows **210**. For example, compressible bellows **210** may move from a compressed position to an uncompressed position due to the expansion force provided by a decrease in the linear density of corrugations **212**. This expansion force may be provided by the tendency of corrugations **212** to move away from one another.

In addition, compressible bellows **210** may be composed of any material that allows the compression and expansion of compressible bellows **210**. The expansion force provided by the corrugated side walls may depend on the material from which compressible bellows **210** is composed. Thus, the amount of pressure provided by compressible bellows **210** to a tissue site, such as tissue site **105** in FIG. 1, may also depend on the material from which compressible bellows **210** is composed. Factors that may affect the amount of pressure provided by compressible bellows **210** include material hardness, elasticity, thickness, resiliency, and permeability. A

10

material may also be selected based on the degree of pressure decay experienced by pump **200** as compressible bellows **210** moves from a compressed position to an uncompressed position. The expansion force provided by the corrugated side walls may also depend on the design of compressible bellows **210**. The variance in cross-section of compressible bellows **210** affects the amount of obtainable reduced pressure as well as the input input pressure required to initiate compressible bellows **210**.

In one non-limiting example, compressible bellows **210** is composed of Shore 65A. Shore 65 A may be capable of providing between 125 and 150 mm Hg of pressure. These levels of pressure may also be capable of being maintained for at least six hours. For higher pressures, harder materials, such as Shore 85 A, may be used. By varying the material from which compressible bellows **210** is composed, pressures of 250 mm Hg, as well as pressures above 400 mm Hg, may be achieved using compressible bellows **210**.

Although compressible bellows **210** is shown to have a circular cross sectional shape, compressible bellows **210** may have any cross sectional shape. For example, the cross sectional shape of compressible bellows **210** may be an oval or polygon, such as a pentagon, hexagon, or octagon.

Compressible bellows **210** includes outlet valve **224**. Outlet valve **224** is a non-limiting example of outlet valve **124** in FIG. 1. Gas exits compressible bellows **210** via outlet valve **224** in response to a movement of bellow pump **210** from an uncompressed position to a compressed position. Outlet valve **224** may be located anywhere on compressible bellows **210**. For example, outlet valve **224** may be located on an end of compressible bellows **210** that is opposite of the end at which filter housing **220** is located. Outlet valve **224** may also be centrally disposed on an end wall of compressible bellows **210**. The directional flow of the gas from compressible bellows **210** is indicated by arrows **226**. Outlet valve **224** prevents gas from entering compressible bellows **210**. In FIG. 2, outlet valve **224** is an umbrella valve, although valve **224** may be any type of valve. Additional details regarding outlet valve **224** are described in FIG. 7 below.

As indicated by dotted lines **228**, compressible bellows **210** is coupled to filter housing **220**. Compressible bellows **210** may be welded, screwed, glued, bolted, air-lock sealed, or snapped onto filter housing **220**. Additional details regarding the coupling between compressible bellows **210** and filter housing **220** are described in FIGS. 5 and 6 below.

Filter housing **220** is a non-limiting example of filter housing **120** in FIG. 1. Filter housing may be composed of any material, such as plastic, metal, rubber, or any other material capable of holding one or more filters. Filter housing **220** contains odor filter **231**, which is attached to filter housing **220** as indicated by dotted lines **236**. Odor filter **231** may be screwed, glued, bolted, air-lock sealed, snapped onto, or otherwise placed adjacent to filter housing **220**. Also, filter housing **220** may include a groove into which odor filter **231** is placed.

Odor filter **231** restrains or prevents the transmission of odor from fixed volume chamber **215** to compressible bellows **210**. Such odor may be the result of exudate or other liquid contained in fixed volume chamber **215**. In one embodiment, odor filter **231** is a carbon odor filter. In this embodiment, the carbon odor filter may include charcoal. Although FIG. 2 depicts odor filter **231** as a having a flattened shape, odor filter **231** may have any shape capable of restraining or preventing the transmission of odor from fixed volume chamber **215** to compressible bellows **210**. For example, odor filter **231** may have circular, ovalar, or polygonal disk shape.

11

Filter housing 220 also includes hydrophobic filter 234, which is attached to filter housing 220 as indicated by dotted lines 238. Hydrophobic filter 234 may be screwed, glued, bolted, air-lock sealed, snapped onto, ultrasonically welded, or otherwise placed adjacent to filter housing 220. In one example, odor filter 231 is sandwiched between filter housing 220 and hydrophobic filter 234. In the example in which hydrophobic filter 234 is secured to filter housing 220, odor filter 231 may be secured as a result of being sandwiched between filter housing 220 and hydrophobic filter 234. Odor filter 231 and hydrophobic filter 234 may be coupled to a side of filter housing 220 that is nearer to fixed volume chamber 215, as shown in FIG. 2.

Hydrophobic filter 234 prevents liquid, such as exudate, from entering compressible bellows 210. However, hydrophobic filter 234 allows the passage of gas, such as air, such that reduced pressure may be transferred from compressible bellows 210 and fixed volume chamber 215. Hydrophobic filter 234 may be composed from any of a variety of materials, such as expanded polytetrafluoroethene.

Pump 200 includes fixed volume chamber 215. Fixed volume chamber 215 is a non-limiting example of fixed volume chamber 115 in FIG. 1. Fixed volume chamber 215 has a fixed volume and may contain any liquid, such as exudate from a tissue site, such as tissue site 105 in FIG. 1. Fixed volume chamber 215 may be welded, screwed, glued, bolted, air-lock sealed, or snapped onto filter housing 220.

Fixed volume chamber 215 includes inlet valve 240. Inlet valve 240 is a non-limiting example of inlet valve 140 in FIG. 1. As shown in FIG. 2, inlet valve 240 is centrally located at an end wall of fixed volume chamber 215. Also, inlet valve 240 and outlet valve 224 are each located along central longitudinal axis 290, which traverses the center of pump 200.

Any liquid, such as exudate, may flow from a manifold, such as manifold 145 in FIG. 1, into fixed volume chamber 215 via inlet valve 240. The flow of liquid into fixed volume chamber 215 via inlet valve 240 is indicated by arrow 242. Inlet valve 240 also restrains or prevents the passage of liquid out of fixed volume chamber 215 at the point at which inlet valve 240 is located.

Any of a variety of valves may be used to achieve the functionality of inlet valve 240. In one embodiment, top portion 246 of inlet valve 240 is a duck bill valve. Inlet valve 240 may also be an umbrella valve, duckbill valve, ball valve, diaphragm valve, and any type of one-way valve.

Liquid flow into fixed volume chamber 215 is caused by the reduced pressure in fixed volume chamber 215. The reduced pressure in fixed volume chamber 215 is caused by the reduced pressure transferred from compressible bellows 210 to fixed volume chamber 215. As compressible bellows 210 is moved from a compressed position to an uncompressed position, gas is transferred from fixed volume chamber 215 to compressible bellows 210. As a result, reduced pressure is transferred to fixed volume chamber 215 from compressible bellows 210 in response to a movement of compressible bellows 210 from a compressed position to an uncompressed position. As compressible bellows 210 is moved from an uncompressed position to a compressed position, gas moves out of compressible bellows 210 via outlet valve 224. Such compression/expansion cycles may be repeated to apply a desired amount of reduced pressure to a tissue site, such as tissue site 105 in FIG. 1.

Turning now to FIG. 3, bellows pump 300, which is a non-limiting example of bellows pump 200 in FIG. 2, is shown in accordance with an illustrative embodiment. In FIG. 3, compressible bellows 300 is shown in two different positions in the range of positions that may be achieved by com-

12

pressible bellows 300. In particular, compressible bellows 300 is shown in uncompressed position 305 and compressed position 310. Compressible bellows 300 has a greater volume in uncompressed position 305 than in compressed position 310.

As compressible bellows 300 is compressed from uncompressed position 305 to compressed position 310, the gas in compressible bellows 300 is expelled through outlet valve 324, which is a non-limiting example of outlet valve 224 in FIG. 2. The volume of compressible bellows 300 decreases during transition 315.

As compressible bellows 300 expands from compressed position 310 to uncompressed position 305, gas does not enter compressible bellows 300 via outlet valve 324 because outlet valve 324 allows air only to exit compressible bellows 300. Instead, gas enters bellows pump from a fixed volume chamber, such as fixed volume chamber 215 in FIG. 2, to which compressible bellows 300 is coupled. The volume of compressible bellows 300 increases as compressible bellows 300 expands from compressed position 310 to uncompressed position 305.

The expansion force necessary to expand compressible bellows 300 is provided by an expansion or biasing force. The material from which compressible bellows 300 is composed is elastically deformed when compressible bellows 300 is in compressed position 310. Elastic properties of the material from which compressible bellows 300 is composed biases the corrugations included on compressible bellows 300 to move away from one another such that compressible bellows 300 expands to uncompressed position 305. As compressible bellows 300 expands, the sealed nature of the variable volume chamber results in a reduced pressure being created within the variable volume chamber. The reduced pressure may then be transmitted through a hydrophobic filter to a fixed volume chamber, which, in turn, transmits the reduced pressure to a tissue site.

Turning now to FIG. 4, a portion of filter housing 420, which is a non-limiting example of filter housing 220 in FIG. 2, is shown in accordance with an illustrative embodiment. Odor filter 431, which is a non-limiting example of odor filter 231 in FIG. 2, fits onto filter housing 420 at groove 432. Hydrophobic filter 434, which is a non-limiting example of hydrophobic filter 234 in FIG. 2, is ultrasonically welded to filter housing 420 at protrusion 439. However, as described above, hydrophobic filter 234 may be coupled to filter housing 420 in a variety of ways. Odor filter 431 is sandwiched in between filter housing 420 and hydrophobic filter 434 at groove 432, and may or may not be independently attached to filter housing 420.

As indicated by arrows 443, gas, such as air, is permitted to flow through hydrophobic filter 434 and odor filter 431, via gap 445. However, hydrophobic filter 434 prevents liquid, such as exudate, from passing through gap 445. Also, odor filter 431 prevents odor from passing through gap 445.

Turning now to FIG. 5, an interlocking seal between compressible bellows 510, which is a non-limiting example of compressible bellows 210 in FIG. 2, and filter housing 520, which is a non-limiting example of filter housing 220 in FIG. 2, is shown in accordance with an illustrative embodiment. The interlocking seal shown in FIG. 5 allows compressible bellows 510 to be snapped onto filter housing 520, while maintaining an air-tight seal for the proper operation of the reduced pressure treatment system. Compressible bellows 510 includes snap protrusion 530. Filter housing 520 includes undercut 540 into which snap protrusion 530 may be inserted. The large area of contact between compressible bellows 510

13

and filter housing 520, as indicated by span 550, assists in maintaining a proper seal between compressible bellows 510 and filter housing 520.

Turning now to FIG. 6, an interlocking seal between compressible bellows 610, which is a non-limiting example of compressible bellows 210 in FIG. 2, and filter housing 620, which is a non-limiting example of filter housing 220 in FIG. 2, is shown in accordance with an illustrative embodiment. Similar to the interlocking seal in FIG. 5, filter housing 620 includes undercut 640 into which snap protrusion 630 of compressible bellows 610 may be inserted. However, in contrast to FIG. 5, the illustrative embodiment of the interlocking seal in FIG. 6 shows that compressible bellows 610 includes ribs 655. Filter housing 620 also includes indentations 660, into which ribs 655 may be inserted. The use of interlocking ribs 655 and indentations 660 may help create a tighter seal between compressible bellows 610 and filter housing 620.

Turning now to FIG. 7, outlet valve 724, which is a non-limiting example of outlet valve 224 in FIG. 2, is shown in accordance with an illustrative embodiment. Outlet valve 724 is coupled to end wall 730 of compressible bellows 710, which is a non-limiting example of compressible bellows 210 in FIG. 2. End wall 730 may be made of metal, plastic, rubber, or any other material. In FIG. 7, end wall 730 may be welded onto compressible bellows 710 at the spans indicated by spans 735. However, end wall 730 may also be screwed, glued, bolted, air-lock sealed, or snapped onto compressible bellows 710.

Gas, such as air, flows out of compressible bellows 710 as indicated by arrows 740. In particular, gas flows out of compressible bellows 710 through gaps 741 and then pass through the space between outlet valve flaps 742 and 743 and end wall 730. However, because flaps 742 and 743 are only opened by the flow of gas out of compressible bellows 710, gas cannot enter compressible bellows 710 through outlet valve 724. In FIG. 7, outlet valve 724 is an umbrella valve. However, outlet valve 724 may be any valve capable of allowing gas to pass out of compressible bellows 710 while restraining or preventing gas from passing out of compressible bellows 710.

Turning now to FIG. 8, a connection between end wall 830, which is a non-limiting example of end wall 730 in FIG. 7, and compressible bellows 810, which is a non-limiting example of compressible bellows 710 in FIG. 7, is shown in accordance with an illustrative embodiment. In contrast to FIG. 7, the illustrative embodiment of FIG. 8 shows protrusion 840 included on compressible bellows 810. End wall 830 also includes indentation 850 into which protrusion 840 may be inserted. The use of protrusion 840 and indentation 850 may help create a tighter seal between compressible bellows 810 and end wall 830, as well as help reduce the amount of welding necessary to couple compressible bellows 810 to end wall 830.

Turning now to FIG. 9, compressible bellows 910, which is a non-limiting example of compressible bellows 210 in FIG. 2, is shown in accordance with an illustrative embodiment. Compressible bellows 910 is coupled to filter housing 920, which is a non-limiting example of filter housing 220 in FIG. 2. In FIG. 9, end wall 930 of compressible bellows 910 does not include an outlet valve. Instead, compressible bellows 910 includes outlet valves at the portions of compressible bellows 910 indicated by brackets 940 and 945. In addition, compressible bellows 910 may include one or more outlet valves around the perimeter of compressible bellows 910 indicated by brackets 940 and 945. Additional details regarding the outlet valves at the portion of compressible bellows 910 indicated by brackets 940 and 945 is described in FIGS. 10-13 below.

14

Turning now to FIG. 10, an umbrella outlet valve that is part of compressible bellows 1010, which is a non-limiting example of compressible bellows 910 in FIG. 9, is shown in accordance with an illustrative embodiment. The outlet valve includes flap 1025. Filter housing 1020, which is a non-limiting example of filter housing 920 in FIG. 9, includes gap 1027. Upon moving compressible bellows 1010 from an uncompressed position to a compressed position, gas flows out of compressible bellows through gap 1027 as indicated by arrow 1029. The flow of gas lifts flap 1025 into open position 1035, as indicated by arrow 1037, thereby allows the passage of gas out of compressible bellows 1010. When air is not flowing out of compressible bellows 1010, such as when compressible bellows is moving from a compressed position to an uncompressed position, flap 1025 is in contact with filter housing 1020 such that gas may not flow into compressible bellows 1010.

In this embodiment, compressible bellows 1010 may also have protrusion 1040, which fits into indentation 1045 of filter housing 1020. The fitting of protrusion 1040 into indentation 1045 helps to maintain a snap fit between compressible bellows 1010 and filter housing 1020.

Turning now to FIG. 11, an outlet valve located on compressible bellows 1110 at the general portion of compressible bellows 1110 that contacts filter housing 1120 is shown in accordance with an illustrative embodiment. Compressible bellows 1110 is a non-limiting example of compressible bellows 910 in FIG. 9, and filter housing 1120 is a non-limiting example of filter housing 920 in FIG. 9.

Upon compression of compressible bellows 1110 from an uncompressed position to a compressed position, gas attempts to flow out of compressible bellows 1110 through gap 1127 as indicated by arrow 1129. The gas encounters flap 1125, which includes rib 1135. The strength of rib 1135, which may depend on the thickness or material of rib 1135, determines the amount of force that must be exerted by the gas in order to bend flap 1125 such that air can escape compressible bellows 1110. Thus, the strength of rib 1135 also determines the amount of pressure that is created by compressible bellows 1110, and which is ultimately transferred to a tissue site, such as tissue site 105 in FIG. 1.

Turning now to FIG. 12, the outlet valve of FIG. 11 in an open position is shown in accordance with an illustrative embodiment. The flow of gas, which is indicated by arrow 1229, has exerted sufficient force upon flap 1225 of compressible bellows 1210 such that flap 1225 has been bent to allow for the release of gas from compressible bellows 1210. In particular, the force exerted by the flow of gas is sufficient to overcome the strengthening force of rib 1235.

Turning now to FIG. 13, an outlet valve located on a side wall of bellow pump 1310, which is a non-limiting example of compressible bellows 1110 and 1210 in FIGS. 11 and 12, respectively, is shown in accordance with an illustrative embodiment. FIG. 13 shows flap 1325, which is a non-limiting example of flaps 1125 and 1225 in FIGS. 11 and 12, respectively. FIG. 13 also shows rib 1335, which is a non-limiting example of ribs 1135 and 1235 in FIGS. 11 and 12, respectively. As described above, rib 1335 may be used to adjust the force required to open flap 1325, thereby varying the amount of pressure that may be created by bellow pump 1310.

Turning now to FIG. 14, reduced pressure treatment system 1400, which is encased by a casing having top casing portion 1402 and bottom casing portion 1404, is shown in accordance with an illustrative embodiment. Reduced pressure treatment system 1400 includes pump 1488, which

15

includes compressible bellows **1410**, filter housing **1420**, odor filter **1431**, hydrophobic filter **1434**, and variable volume chamber **1415**.

FIG. **14** shows the orientation of the different components of reduced pressure treatment system **1400** relative to one another. Compressible bellows **1410**, which is a non-limiting example of compressible bellows **210** in FIG. **2**, may be inserted into top casing portion **1402**. Top casing portion also includes grip **1403**. Grip **1403** may be composed of rubber, plastic, or any other material capable of improving tactile grip on top casing portion **1402**.

The cross sectional shape of compressible bellows **1410** is an oval. In particular, compressible bellows **1410** has an elongated middle portion **1412** and rounded end portions **1414**. The cross sectional shape of compressible bellows **1410** allows compressible bellows **1410** to fit into top casing portion **1402**. The cross sectional shape of compressible bellows **1410** may vary depending on the shape of the casing for the reduced pressure treatment system.

Compressible bellows **1410** couples to filter housing **1420**, which is a non-limiting example of filter housing **220** in FIG. **2**. Filter housing **1420** includes grid mesh **1425** through which gas may flow.

Odor filter **1431** and hydrophobic filter **1434**, which are non-limiting examples of odor filter **231** and hydrophobic filter **234** in FIG. **2**, respectively, fit into filter housing **1420** as described in the previous Figures. Fixed volume chamber **415**, which is a non-limiting example of fixed volume chamber **215** in FIG. **2**, couples to filter housing **1420**. Fixed volume chamber **415** may be inserted into bottom casing portion **1404**.

Top casing portion **1402** and bottom casing portion **1404** may be composed of any material. For example, top casing portion **1402** and bottom casing portion **1404** may be composed of materials that are suitable to protect the inner components of reduced pressure treatment system **1400**. Non-limiting examples of the material from which top casing portion **1402** and bottom casing portion **1404** may be composed include plastic, metal, or rubber.

Turning now to FIG. **15**, compressible bellows **1510** and **1512**, each of which is a non-limiting example of compressible bellows **210** in FIG. **2**, is shown in accordance with an illustrative embodiment. Compressible bellows **1510** and **1512** can replace the oval compressible bellows **1410** in FIG. **14**. Thus, compressible bellows **1510** and **1512** may be configured to be inserted into a top casing portion, such as top casing portion **1402** in FIG. **14**. Each of compressible bellows **1510** and **1512** are coupled to filter housing **1520**, which is a non-limiting example of filter housing **1420** in FIG. **14**.

The use of two compressible bellows **1510** and **1512** allows the reduced pressure treatment system in which compressible bellows **1510** and **1512** are employed to continue functioning in the event that one of the compressible bellows leaks or otherwise fails. The use of compressible bellows **1510** and **1512** may also improve manufacturing efficiency in the construction of a reduced pressure treatment system. For example, the manufacture of compressible bellows **1510** and **1512** having a circular cross-section may be easier than the manufacture of a single compressible bellows having an elongated cross section that allows the single compressible bellows to fit inside top casing portion **1402**.

Turning now to FIG. **16**, reduced pressure treatment system **1600**, which is a non-limiting example of reduced pressure treatment system **1400** in FIG. **14**, is shown in accordance with an illustrative embodiment. Reduced pressure treatment system **1600** shows reduced pressure treatment system **1400** when reduced pressure treatment system **1400** has

16

been assembled. In reduced pressure treatment system **1600**, top and bottom casing portions **1602** and **1604** encase the various components of reduced pressure treatment system **1600**, such as a compressible bellows, filter housing, odor filter, hydrophobic filter, and fixed volume chamber. Top and bottom casing portions **1602** and **1604** are non-limiting examples of top and bottom casing portions **1402** and **1404** in FIG. **14**, respectively.

Reduced pressure treatment system **1600** also includes visual indicators **1608**. Visual indicators **1608** indicate to a user an amount of reduced pressure to be delivered to a tissue site, such as tissue site **105** in FIG. **1**. In particular, the lines of visual indicators **1608** indicate the degree to which top casing portion **1602** has been compressed relative to bottom casing portion **1604**, and therefore also indicates the degree to which the one or more compressible bellows inside top casing portion **1502** has been compressed. Using visual indicators **1608**, a user can consistently deliver a desired amount of reduced pressure to a tissue site.

Reduced pressure treatment system also includes end cap **1612**. End cap **1512** fits onto bottom casing portion **1604** and may be coupled to delivery tube **1635**, which is a non-limiting example of delivery tube **135** in FIG. **1**. Additional details regarding end cap **1512** will be described in FIGS. **17** and **18** below.

Turning now to FIG. **17**, the fitting between bottom casing portion **1704**, which is a non-limiting example of bottom casing portion **1604** in FIG. **14**, and end cap **1712**, which is a non-limiting example of end cap **1612** in FIG. **16**, is shown in accordance with an illustrative embodiment. End cap **1712** fits onto bottom casing portion **1704** at bottom casing portion end groove **1716**. End cap **1712** includes inlet valve connector **1721**, which may be coupled to an inlet valve on fixed volume chamber **1715**. Thus, liquid, such as exudate, may be delivered to fixed volume chamber **1715** through a delivery tube via inlet valve connector **1721**. End cap **1712** may be welded, screwed, glued, bolted, air-lock sealed, snapped, or otherwise coupled to bottom casing portion **1704**.

Turning now to FIG. **18**, bottom casing portion **1804**, which is a non-limiting example of bottom casing portion **1704** in FIG. **17**, is shown coupled to end cap **1812**, which is a non-limiting example of end cap **1712** in FIG. **17**, in accordance with an illustrative embodiment. In FIG. **17**, end cap **1812** is shown to be attached to bottom casing portion **1804** and delivery tube **1835**. Delivery tube **1835** is a non-limiting example of delivery tube **135** in FIG. **1**. In this illustrative embodiment of FIG. **17**, delivery tube **1835** extends upwardly toward bottom casing portion **1804** at the point at which delivery tube **1835** protrudes from end cap **1812**. This upward orientation of delivery tube **1835** may allow a user to place reduced pressure delivery system **1800** in convenient or otherwise desirable locations, such as on a clothes garment. In one example, reduced pressure treatment system **1800** may be placed in a pocket, sock, or on a belt during treatment. When used on a belt, the casing of reduced pressure treatment system **1800** may also include a belt clip.

Turning now to FIG. **19**, a process that may be implemented by a manually-actuated pump, such as pump **102** in FIG. **1** or any other illustrative embodiment of the reduced pressure treatment system described above, is shown in accordance with an illustrative embodiment.

The process compresses a variable volume chamber having a variable volume from an uncompressed position to a compressed position (step **1905**). The process determines whether the compressed position yields a threshold level of reduced pressure as indicated by an indicator, such as visual indicators **1608** in FIG. **16** (step **1910**). If the process determines that the

17

compressed position does not yield a threshold level of reduced pressure as indicated by an indicator, the process further compresses or expands the variable volume chamber (step 1915). The process then returns to step 1910.

If the process determines that the compressed position yields a threshold level of reduced pressure as indicated by an indicator, the process may then expand the variable volume chamber from the compressed position to the uncompressed position (step 1920). The process transfers reduced pressure from the variable volume chamber to a fixed volume chamber (step 1925). The process may then transfer the reduced pressure to a tissue site via a manifold and delivery tube (step 1930).

The flowcharts and block diagrams in the different depicted embodiments illustrate the architecture, functionality, and operation of some possible implementations of the apparatus and methods. In some alternative implementations, the function or functions noted in the block may occur out of the order noted in the figures. For example, in some cases, two blocks shown in succession may be executed substantially concurrently, or the blocks may sometimes be executed in the reverse order, depending upon the functionality involved.

The illustrative embodiments described herein separate the chambers in which exudates and other liquids are collected from the reduced-pressure-generating chamber. Thus, the compressible pumps are capable of being re-charged (i.e. the flexible bellows can be re-depressed) even when liquids are present in the fixed volume chamber. When the fixed volume chamber becomes completely full of exudate or other liquids, the fixed volume chamber may then be emptied before additional reduced pressure may be applied by the compressible pump. Also, the illustrative embodiments, unlike traditional manually-activated systems, are capable of delivering a measured and consistent amount of pressure to a tissue site during a particular reduced pressure treatment cycle. The illustrative embodiments are further capable of consistently repeating the targeted pressure each time the compressible pump is recharged. These pressure delivery capabilities exist regardless of the orientation or location of the fixed volume chamber.

We claim:

1. A manually-actuated pump for applying reduced pressure at a tissue site, the manually-actuated pump comprising:
 a casing having a top casing portion and a bottom casing portion;
 at least one variable volume chamber disposed within the casing that is manually compressible into a plurality of positions;
 a fixed volume chamber disposed within the casing and being in communication with the at least one variable volume chamber; and
 a filter housing disposed within the casing between the fixed volume chamber and the at least one variable volume chamber, the filter housing having a hydrophobic filter that prevents liquid from entering the at least one variable volume chamber, the fixed volume chamber having reduced pressure that is applied to the tissue site in response to a movement of the at least one variable volume chamber from a compressed position in the plurality of positions to an uncompressed position in the plurality of positions;
 wherein the top casing portion is configured to slide relative to the bottom casing portion as the at least one variable volume chamber moves from the compressed position to the uncompressed position.

18

2. The apparatus of claim 1, wherein the filter housing includes an odor filter that restrains a transmission of odor from the fixed volume chamber to the at least one variable volume chamber.

3. The apparatus of claim 2, wherein the odor filter is a carbon odor filter comprising charcoal.

4. The apparatus of claim 3, wherein the hydrophobic filter and the odor filter are coupled to a side of the filter housing that is nearer to the fixed volume chamber.

5. The apparatus of claim 4, wherein the odor filter is sandwiched between the filter housing and the hydrophobic filter.

6. The apparatus of claim 1, wherein the at least one variable volume chamber is at least one bellows, and wherein the at least one bellows comprises at least one corrugated side wall to form at least one compressible bellows.

7. The apparatus of claim 6, wherein the at least one corrugated side wall comprises an elastic resilient material, wherein the movement of the at least one variable volume chamber from the compressed position to the uncompressed position is caused by an expansion force, and wherein the expansion force is caused by an expansion of the at least one corrugated side wall.

8. The apparatus of claim 6, wherein the at least one compressible bellows has an oval cross sectional shape.

9. The apparatus of claim 1, wherein the liquid is exudate at the tissue site, further comprising:

a manifold, wherein the reduced pressure in the fixed volume chamber causes the exudate to move from the tissue site to the fixed volume chamber via the manifold.

10. The apparatus of claim 9, wherein the fixed volume chamber further comprises:

an inlet valve at an inlet point, wherein the exudate flows from the manifold into the fixed volume chamber via the inlet valve, and wherein the inlet valve prevents the exudate from exiting the fixed volume chamber at the inlet point.

11. The apparatus of claim 10, wherein the inlet valve is located at the center of a bottom wall of the fixed volume chamber.

12. The apparatus of claim 11, further comprising:

a delivery tube coupling the fixed volume chamber to the manifold, wherein the exudate moves from the manifold to the fixed volume chamber through the delivery tube.

13. The apparatus of claim 12, wherein the at least one variable volume chamber further comprises:

at least one outlet valve, wherein gas exits the at least one variable volume chamber via the at least one outlet valve in response to a second movement of the at least one variable volume chamber from the uncompressed position to the compressed position, and wherein the at least one outlet valve prevents gas from entering the at least one variable volume chamber through the at least one outlet valve.

14. The apparatus of claim 13, wherein the at least one outlet valve and the inlet valve are located along a central longitudinal axis of the manually-actuated pump.

15. The apparatus of claim 13, wherein the at least one outlet valve is centrally located on a top wall of the at least one variable volume chamber.

16. The apparatus of claim 13, wherein the at least one outlet valve is located on at least one side wall of the at least one variable volume chamber.

17. The apparatus of claim 1, wherein the at least one variable volume chamber is sealingly coupled to the filter housing by at least one interlocking seal.

19

18. The apparatus of claim 1, wherein the at least one variable volume chamber has a larger volume in the uncompressed position than in the compressed position.

19. The apparatus of claim 1, further comprising:

a pressure feedback system, wherein the pressure feedback system indicates an amount of reduced pressure being applied by the at least one variable volume chamber.

20. A manually-actuated pump for applying reduced pressure at a tissue site, the manually-actuated pump comprising: a casing having a top casing portion and a bottom casing portion;

at least one compressible bellows positioned in the casing that is compressible into a plurality of positions, the at least one compressible bellows having at least one corrugated side wall, the at least one corrugated side wall comprising an elastic resilient material;

a fixed volume chamber positioned in the casing having an inlet valve at an inlet point, wherein exudate flows from the tissue site into the fixed volume chamber via the inlet valve, the inlet valve preventing the exudate from exiting the fixed volume chamber at the inlet point, the inlet valve being located at the center of a bottom wall of the fixed volume chamber;

a filter housing positioned in the casing and disposed between the fixed volume chamber and the at least one compressible bellows, the filter housing having a hydrophobic filter that prevents exudate from entering the at least one compressible bellows and a carbon odor filter that restrains a transmission of odor from the fixed volume chamber to the at least one compressible bellows via the filter housing, the fixed volume chamber having reduced pressure that is applied to the tissue site in response to a movement of the at least one compressible bellows from a compressed position in the plurality of positions to an uncompressed position in the plurality of positions, the movement being caused by an expansion force from the at least one corrugated side wall; and

at least one outlet valve through which gas exits the at least one compressible bellows in response to a second movement of the at least one compressible bellows from the uncompressed position to the compressed position, the at least one outlet valve preventing the gas from entering the at least one compressible bellows through the at least one outlet valve;

20

wherein the to casing portion is configured to slide relative to the bottom casing portion as the at least one variable volume chamber moves from the compressed position to the uncompressed position.

21. A manually-actuated pump for applying reduced pressure at a tissue site, the manually-actuated pump comprising: at least one variable volume chamber that is manually compressible into a plurality of positions;

a fixed volume chamber in communication with the at least one variable volume chamber;

a filter housing having a hydrophobic filter that prevents liquid from entering the at least one variable volume chamber, the filter housing being located in between the at least one variable volume chamber and the fixed volume chamber, the fixed volume chamber having reduced pressure that is applied to the tissue site in response to a movement of the at least one variable volume chamber from a compressed position in the plurality of positions to an uncompressed position in the plurality of positions; and

a casing enclosing the at least one variable volume chamber, the fixed volume chamber, and the filter housing; wherein the at least one variable volume chamber and the fixed volume chamber are directly coupled to the filter housing; and

wherein the casing has two portions configured to slide relative to each other as the at least one variable volume chamber moves from the compressed position to the uncompressed position.

22. The manually-actuated pump of claim 21, wherein the at least one variable volume chamber further comprises:

at least one outlet valve, wherein gas exits the at least one variable volume chamber via the at least one outlet valve in response to a second movement of the at least one variable volume chamber from the uncompressed position to the compressed position, and wherein the at least one outlet valve prevents gas from entering the at least one variable volume chamber through the at least one outlet valve.

23. The manually-actuated pump of claim 21, further comprising:

a pressure feedback system, wherein the pressure feedback system indicates an amount of reduced pressure being applied by the at least one variable volume chamber.

24. The manually-actuated pump of claim 21, wherein the at least one variable volume chamber is at least one bellows.

* * * * *