

Filed May 19, 2025

On behalf of **Imperative Care, Inc.**

By: Joshua J. Stowell (Reg. No. 64,096)
Joseph R. Re (Reg. No. 31,291)
Brian C. Barnes (Reg. No. 75,805)
KNOBBE, MARTENS, OLSON & BEAR, LLP
2040 Main Street, 14th Floor
Irvine, CA 92614
Tel.: (949) 760-0404
Fax: (949) 760-9502
Email: BoxImperative333@knobbe.com

UNITED STATES PATENT AND TRADEMARK OFFICE

BEFORE THE PATENT TRIAL AND APPEAL BOARD

IMPERATIVE CARE, INC.,
Petitioner,

v.

INARI MEDICAL, INC.,
Patent Owner.

Case IPR2025-01021
Patent No. 11,969,333

**PETITION FOR *INTER PARTES* REVIEW OF
U.S. PATENT NO. 11,969,333**

TABLE OF CONTENTS

Page No(s).

I.	INTRODUCTION	1
II.	THE '333 PATENT	7
	A. Overview	7
	B. Prosecution History	11
	C. Earliest Possible Priority Date.....	13
III.	LEVEL OF ORDINARY SKILL	13
IV.	CLAIM CONSTRUCTION	13
V.	STATEMENT OF RELIEF REQUESTED	15
	A. IPR Grounds	15
	B. The Asserted References Are Prior Art	17
	C. The Asserted References Are Analogous Art	17
VI.	FOUNDATIONS 1A, 2A, 3A, 4A – LAUB, AKLOG, AND GARRISON.....	18
	A. Claim 1	18
	1. Preamble.....	18
	a. Laub	18
	b. Aklog	19
	c. Garrison and Laub Or Aklog	20
	2. Advancing Aspiration Catheter.....	30

TABLE OF CONTENTS
(cont'd)

	Page No.
a. Laub	30
b. Aklog	32
c. Garrison and Laub or Aklog	34
3. Generating Vacuum Pressure With Valve In First Position.....	36
a. Garrison	36
b. Laub or Aklog and Garrison.....	38
4. Moving The Valve From First To Second Position.....	41
5. Filter	43
B. Claim 2	43
1. Laub.....	43
2. Aklog.....	43
3. Garrison and Laub or Aklog	44
C. Claim 3	44
1. Laub.....	45
2. Aklog.....	45
3. Garrison and Laub or Aklog	45
D. Claim 4	45
E. Claim 5	46

TABLE OF CONTENTS
(cont'd)

	Page No.
1. Laub.....	46
2. Aklog.....	47
3. Garrison.....	47
F. Claim 9	48
G. Claim 10	49
1. Garrison.....	50
2. Laub and Garrison.....	51
3. Aklog and Garrison.....	52
H. Claim 14	52
1. Laub.....	53
2. Aklog.....	53
3. Garrison.....	54
I. Claim 15	55
1. Laub.....	55
2. Aklog.....	55
3. Garrison.....	56
J. Claim 16	56
1. Garrison.....	56

TABLE OF CONTENTS
(cont'd)

	Page No.
2. Laub and Aklog.....	58
K. Claim 18	60
1. Laub.....	61
2. Aklog.....	61
3. Garrison and Laub or Aklog	62
L. Claim 19	62
M. Claims 20-24, 28-29, 33-35, 37-38	63
1. Laub.....	63
2. Aklog.....	64
3. Garrison and Laub or Aklog	64
VII. GROUND 1B, 2B, 3B, 4B – LAUB, AKLOG, AND GARRISON WITH GOFF	65
A. Claim 6	65
B. Claim 7	72
C. Claim 8	72
1. Laub.....	73
2. Aklog.....	74
3. Garrison.....	74
D. Claim 17	75

TABLE OF CONTENTS
(cont'd)

	Page No.
E. Claims 25-27 and 36.....	76
VIII. GROUND 1C-1D, 2C-2D, 3C-3D, 4C-4D – LAUB, AKLOG, AND GARRISON WITH SCHAFFER AND OPTIONALLY HARTLEY.....	77
A. Claim 11	77
1. Schaffer	78
2. Schaffer and Hartley	83
B. Claim 12	88
C. Claims 30-31	89
IX. SECONDARY CONSIDERATIONS	90
X. <i>SOTERA</i> STIPULATION.....	90
XI. MANDATORY NOTICES, GROUNDS FOR STANDING, AND FEE PAYMENT	90
A. Real Parties-In-Interest (37 C.F.R. §42.8(b)(1)).....	90
B. Related Matters (37 C.F.R. §42.8(b)(2)).....	90
C. Lead and Backup Counsel (37 C.F.R. §42.8(b)(3)).....	92
D. Service Information (37 C.F.R. §42.8(b)(4)).....	92
E. Grounds for Standing (37 C.F.R. §42.104).....	93
F. Payment of Fees (37 C.F.R. §42.15(a))	93
XII. CONCLUSION.....	93

TABLE OF AUTHORITIES

Page No(s).

<i>Apple v. Fintiv</i> , IPR2020-00019, Paper 11 (PTAB Mar. 20, 2020)	90
<i>Imperative Care v. Inari Medical, Inc.</i> , IPR2024-01157, Paper 5 (Oct. 29, 2024)	79, 85
<i>KSR Int’l Co. v. Teleflex Inc.</i> , 550 U.S. 398 (2007).....	<i>passim</i>
<i>In re Nilssen</i> , 851 F.2d 1401 (Fed. Cir. 1988)	18
<i>Phillips v. AWH Corp.</i> , 415 F.3d 1303 (Fed. Cir. 2005)	13
<i>Unwired Planet, LLC v. Google Inc.</i> , 841 F.3d 995 (Fed. Cir. 2016)	17

OTHER AUTHORITIES

35 U.S.C. §102	17
37 C.F.R. §1.11	79
37 C.F.R. §42.100	13

LIST OF EXHIBITS

Exhibit No.	Description
1001	U.S. Patent No. 11,969,333 (“the ’333 patent”)
1002	’333 Patent Prosecution History
1003	Expert Declaration of Troy Thornton
1004	Resume of Troy Thornton
1005	U.S. Patent No. 8,734,374 B2 to Aklog et al. (“Aklog”)
1006	U.S. Patent Publication No. 2015/0173782 A1 to Garrison et al. (“Garrison”)
1007	WIPO Publication No. WO 2006/124307 A2 to Goff et al. (“Goff”)
1008	U.S. Patent Publication No. 2003/0116731 A1 to Hartley (“Hartley”)
1009	U.S. Patent No. 6,776,770 B2 to Trerotola (“Trerotola”)
1010	U.S. Patent Publication No. 2010/0042118 A1 to Garrison et al.
1011	U.S. Patent No. 8,535,283 B2 to Heaton et al. (“Heaton”)
1012	U.S. Patent Publication No. 2017/0043066 A1 to Laub (“Laub”)
1013	U.S. Patent Publication US 2003/0225379 A1 to Schaffer et al. (“Schaffer”)
1014	U.S. Patent No. 5,938,645 to Gordon (“Gordon”)
1015	U.S. Patent Publication No. 2014/0296868 A1 to Garrison et al.
1016	U.S. Patent No. 7,998,104 B2 to Chang (“Chang”)
1017	U.S. Patent No. 8,157,760 B2 to Criado et al. (“Criado”)
1018	U.S. Patent No. 6,481,439 B1 to Lewis et al. (“Lewis”)
1019	U.S. Patent No. 8,075,510 B2 to Aklog et al.

Exhibit No.	Description
1020	WIPO Publication No. WO 2018/019829 A1 to Brady et al. (“Brady”)
1021	U.S. Patent Application No. 16/117,519 (the “519 application”)
1022	Expert Declaration of Dr. Aquilla S. Turk, III, DO
1023	Resume of Dr. Aquilla Turk, III, D.O.
1024	Shani, Jacob M.D., et al., Mechanical Manipulation of Thrombus: Coronary Thrombectomy, Intracoronary Clot Displacement, and Transcatheter Aspiration, 72 Am. J. Cardiol. 116G-118G (1993)
1025	Bose, A et al., The Penumbra System: A Mechanical Device for the Treatment of Acute Stroke due to Thromboembolism, 29 Am. J. Neuroradiol. 1409-1413 (Aug. 2008)
1026	Turk, Aquilla S. et al., Initial clinical experience with the ADAPT technique: A direct aspiration first pass technique for stroke thrombectomy, 6 J. NeuroIntervent. Surg. 231-237 (2014)
1027	Turk, Aquilla S. et al., ADAPT FAST study: a direct aspiration first pass technique for acute stroke thrombectomy, 6 J. NeuroIntervent. Surg. 260-264 (2014)
1028	April 24, 2024 Letter from Inari to Imperative Care
1029	Turk, Aquilla S. et al., Aspiration thrombectomy versus stent retriever thrombectomy as first-line approach for large vessel occlusion (COMPASS): a multicentre, randomized, open label, blinded outcome, non-inferiority trial, 393 Lancet 998-1008 (March 2019)
1030	Save, Jeffrey L., Time is Brain – Quantified, American Heart Association Journals, available at http://www.stokeaha.org (2005).
1031	U.S. Patent No. 9,980,813 B1 to Eller (“Eller”)
1032	US 2018/0064453 A1 (“Garrison II”)
1033	US 2005/0054995 A1 (“Barzell”)

Exhibit No.	Description
1034	Decision Granting Institution of <i>Inter Partes</i> Review for U.S. Patent No. 11,697,011 (Paper 7) in <i>Imperative Care, Inc. v. Inari Medical, Inc.</i> , IPR2024-01157 (P.T.A.B. Jan. 23, 2025)
1035	Decision Granting Institution of <i>Inter Partes</i> Review for U.S. Patent No. 11,697,012 (Paper 6) in <i>Imperative Care, Inc. v. Inari Medical, Inc.</i> , IPR2025-00156 (P.T.A.B. Apr. 22, 2025)
1036	U.S. Patent No. 12,109,384 B2 to Merritt et al.
1037	Patent Owner’s Exhibit 2002 filed in <i>Imperative Care, Inc. v. Inari Medical, Inc.</i> , IPR2025-00289 (P.T.A.B.)
1038	Indigo Aspiration System-Penumbra Engine Pump and Canister, 510(k) No. K180105 (Mar. 8, 2018) (“Indigo Aspiration System”)
1039	AXS Universal Aspiration Set Brochure (2017)
1040	VacLok Negative Pressure Syringe Brochure
1041	O. Nikoubashman et al., Under Pressure: Comparison of Aspiration Techniques for Endovascular Mechanical Thrombectomy, 39 Am. J. Neuroradiol. 905-909 (May 2018) (“Nikoubashman”)
1042	Inari’s Supplemental Infringement Contentions (without claim charts) from <i>Inari Medical, Inc. v. Imperative Care, Inc.</i> , No. 24-cv-3117 (N.D. Cal.) (served February 7, 2025)
1043	Inari’s Notice of Motion and Motion for Leave to File Third Amended Complaint (Dkt. #88) in <i>Inari Medical, Inc. v. Imperative Care, Inc.</i> , 24-cv-03117-EKL (N.D. Cal.) (filed March 5, 2025)
1044	Case Management & Scheduling Order (Dkt. #54) in <i>Inari Medical, Inc. v. Imperative Care, Inc.</i> , 24-cv-03117-EKL (N.D. Cal.) (issued December 19, 2024)
1045	Decision Denying Institution of <i>Inter Partes</i> Review for U.S. Patent No. 11,744,691 (Paper 10) in <i>Imperative Care, Inc. v. Inari Medical, Inc.</i> , IPR2024-01257 (P.T.A.B. Feb. 7, 2025)
1046	U.S. Patent No. 7,984,730 B2 to Ziv et al.
1047	Imperative Care’s Opposition to Inari’s Motion for Leave to File Third Amended Complaint (Dkt. #98) in <i>Inari Medical, Inc. v.</i>

Exhibit No.	Description
	<i>Imperative Care, Inc.</i> , 24-cv-03117-EKL (N.D. Cal.) (filed March 26, 2025)
1048	Imperative Care’s Notice of Motion and Motion to Stay Pending <i>Inter Partes</i> Review (Dkt. #100) in <i>Inari Medical, Inc. v. Imperative Care, Inc.</i> , 24-cv-03117-EKL (N.D. Cal.) (filed April 2, 2025)
1049	Ahmed Pasha et al., Successful Management of Acute Massive Pulmonary Embolism Using Angiovac Suction Catheter Technique in a Hemodynamically Unstable Patient, 15 <i>Cardiovasc. Revasc. Med.</i> 240-243 (2014)
1050	Certified File History of U.S. Patent Application 10/371,190 (Schaffer File History)
1051	Maureen Kohi, Catheter Directed Interventions for Acute Deep Vein Thrombosis, 6 <i>Cardiovasc. Diagn. Ther.</i> 599-611 (2016)

Petitioner Imperative Care, Inc. (“Petitioner”) requests *inter partes* review (“IPR”) of Claims 1-12, 14-31, and 33-38 of U.S. Patent No. 11,969,333 (“the ’333 patent,” Ex. 1001), which is assigned to Inari Medical, Inc. (“Patent Owner” or “PO”).

I. INTRODUCTION

Patent Owner has asserted Claims 1-4, 6-12, 14-23, 25-31, and 33-38 against Petitioner in the co-pending district court litigation (the “Litigation”). *See* Ex. 1042 (PO’s infringement contentions). The Litigation is in its early stages and no trial date has been set. (*See* Ex. 1043, 2 (representing that “discovery is at an early stage”); Ex. 1044 (setting case schedule to claim construction).) PO has also alleged that Petitioner’s future products may infringe Claims 5 and 24. Therefore, Petitioner challenges the patentability of these claims in this IPR.

The accumulation of unwanted material, such as blood clots, in a patient’s vasculature can cause serious conditions, including stroke and death. Over the last several decades, medical device companies have developed devices and methods to remove such undesirable material from the vasculature, including catheter-based systems that aspirate (i.e., suction) the material from the blood vessel.

The ’333 patent claims methods of aspirating clot material to treat a pulmonary embolism (“PE”) or deep vein thrombosis (“DVT”). However, the patent provides little description regarding what is new and nonobvious about the claimed

methods. The patent generically states, “there exists a need for improved systems and methods for embolic extraction” and argues that prior art systems were “highly complex,” “cause trauma to the treatment vessel,” and “may not completely capture and/or collect all of the clot material.” (Ex. 1001, 2:33-46.) Yet, the ’333 patent does not explain how the claimed methods address these alleged shortcomings.

Instead, the claims merely recite a method of treating clots using conventional aspiration components, including an aspiration source (e.g., pump or syringe) [red], an aspiration catheter [orange], a filter [blue], a valve positioned in the fluid path [purple], and a hemostasis valve [yellow]:

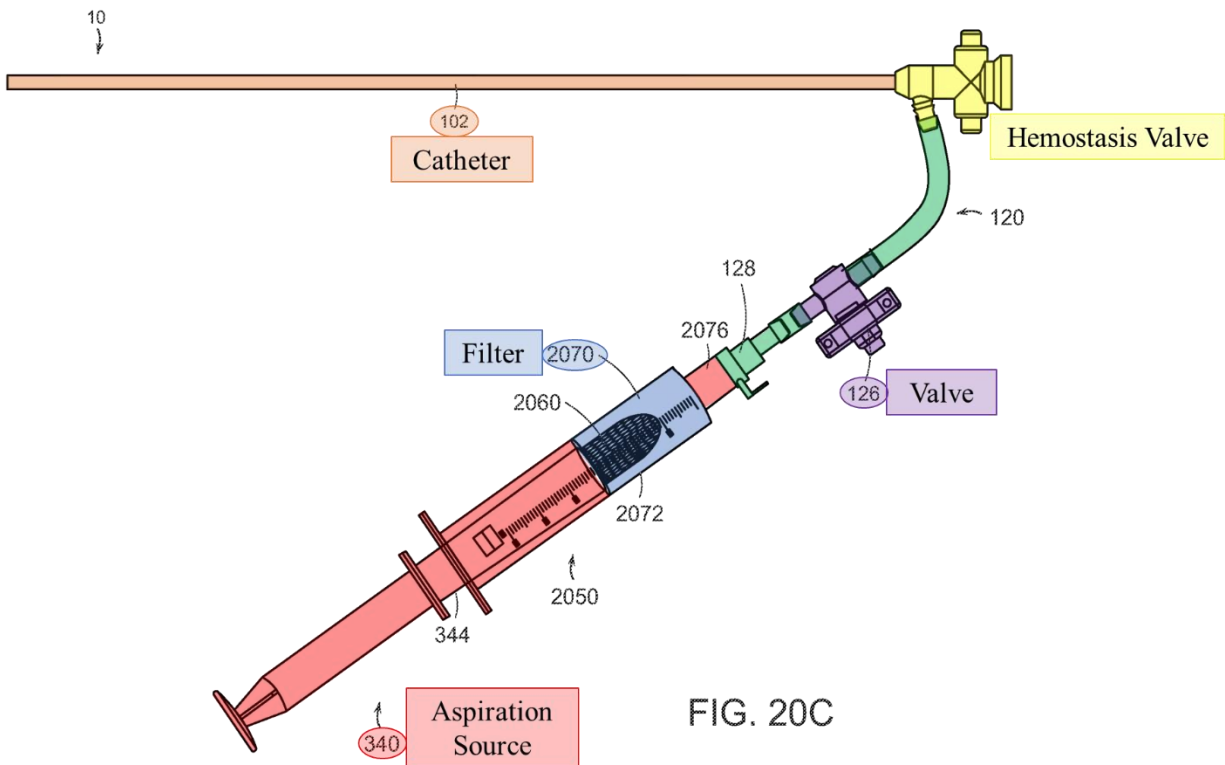

(*Id.*, Fig. 20C.) Aspiration catheters having these conventional components were known before August 2018, the earliest claimed priority date of the ’333 patent.

Laub, a prior art patent application published in February 2017, discloses an aspiration “system for removing thrombi and other unwanted material from the body of a patient, particularly from the patient’s vasculature.” (Ex. 1012, [0005].) Laub describes using its system to treat PE or DVT. (*Id.*, [0005], [0025].) Like the aspiration systems in the ’333 patent, Laub’s system includes an aspiration catheter 200 [orange], a fluid path 250 [green] that places the catheter in communication with a pump 400 [red], and a filter [blue] positioned between the catheter and pump:

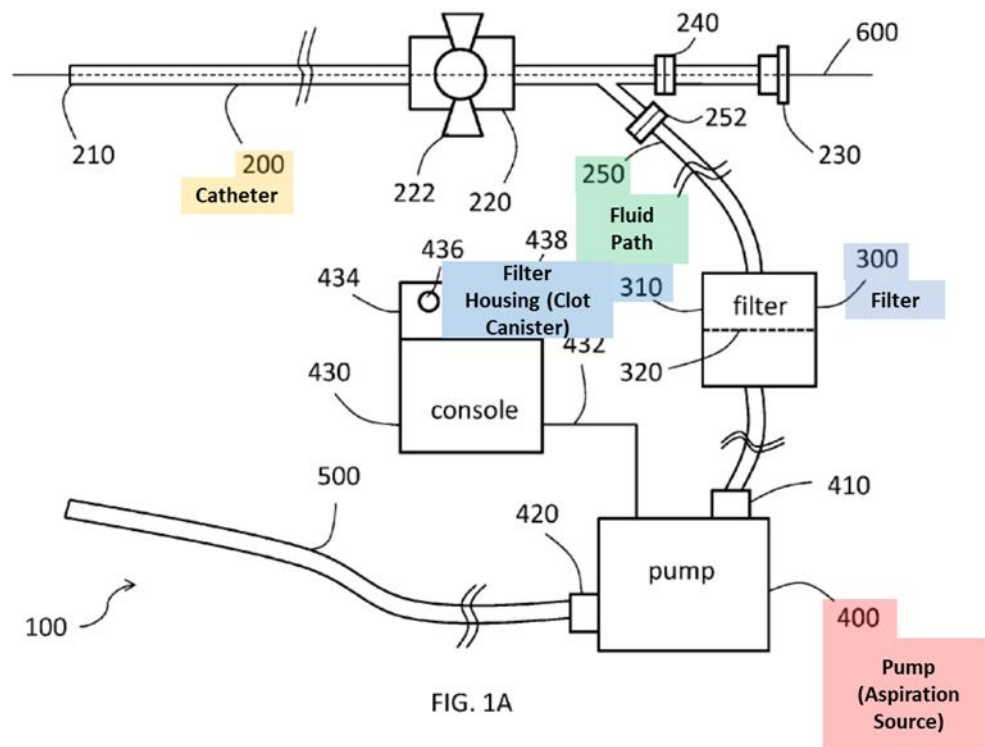

(Ex. 1012, [0024], [0039]-[0040], Fig. 1A.) Laub was *not* of record during prosecution of the ’333 patent.

Aklog's parent (Patent No. 8,075,510), which does not include Figure 7 above, was listed on an IDS but not applied by the Examiner.

The '333 patent claims also recite the steps of (1) generating vacuum pressure within the clot canister while a valve along the fluid path is in a first position that inhibits flow along the fluid path and (2) moving the valve to a second position to open the valve and apply vacuum pressure to aspirate the clot material into clot canister. The '333 patent speculates that “pre-charging or storing the vacuum before applying the vacuum to the lumen 104 of the catheter 102 is expected to generate greater suction forces (and corresponding fluid flow velocities) at and/or near the distal portion 103a of the catheter 102 compared to simply activating the pressure source 140.” (Ex. 1001, 6:55-7:23.) However, as shown below, aspiration catheters that could release a stored vacuum were not new.

Garrison, a prior art patent application published in June 2015, describes an aspiration system for removing unwanted material from a patient's vasculature. Garrison's aspiration system includes the same components as Claim 1 of the '333 patent: an aspiration source [red], an aspiration catheter [orange], a clot canister with a filter [blue], hemostasis valves [yellow], and a user-actuatable valve [purple] that is closed while the aspiration source generates vacuum pressure and opened after the pressure is generated to cause aspiration through the catheter.

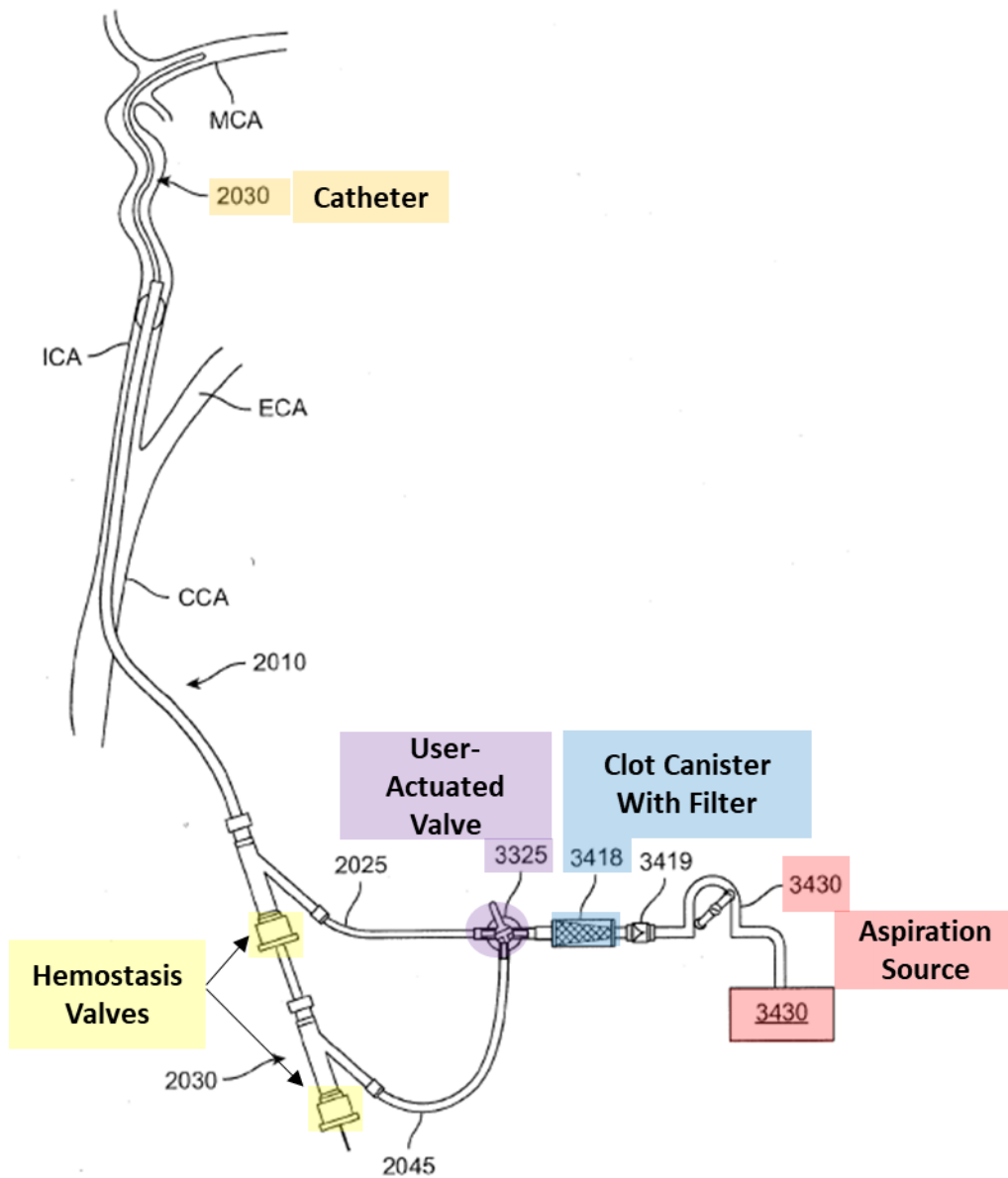

FIG. 34

(Ex. 1006, [0134], Fig. 34.)

The '333 patent claims are directed to methods of treating a PE or DVT. Garrison discloses methods of removing cerebral occlusions but does not specifically mention PE or DVT. However, as shown herein, similar aspiration

systems were disclosed in both Laub and Aklog for treating PE and DVT, and a person of ordinary skill in the art (“POSITA”) would have found it obvious to incorporate Garrison’s valve (e.g., stopcock) into Laub’s or Aklog’s systems to enable “the maximum level of aspiration in a rapid fashion.” (*Id.*, [0134].) POSITAs would have also found it obvious to use and optimize Garrison’s aspiration system to treat PE or DVT based on Laub and Aklog.

Fundamentally, the challenged claims merely recite methods of using known aspiration systems or combinations of known aspiration systems with prior art components according to their known functions to predictably aspirate known clots. *KSR Int’l Co. v. Teleflex Inc.*, 550 U.S. 398, 416 (2007). The prior art grounds identified in this Petition show a reasonable likelihood that one or more claims of the ’333 patent are unpatentable. Thus, Petitioner requests that the Board institute this IPR to reconsider the patentability of the ’333 patent.

II. THE ’333 PATENT

A. Overview

The ’333 patent describes an aspiration system for intravascular removal of clot material. (Ex. 1001, 4:17-4:33.) The ’333 patent alleges that the system can treat various clots including PE, cerebral embolism, and DVT. (*Id.*, 4:51-4:58.) The aspiration system comprises an “assembly 10” including “catheter subsystem 100”, “pressure source 140,” and “tubing subsystem 120.” (*Id.*, 5:28-5:30.)

The catheter subsystem includes an aspiration catheter 102 [orange] “comprising an elongated shaft defining a lumen 104,” and a “valve 106” [yellow] with a “lumen 109 extending therethrough.” (*Id.*, 5:23-5:50.) The valve “is configured to maintain hemostasis during a clot removal procedure by preventing fluid [blood] flow in the proximal direction through the valve 106.” (*Id.*)

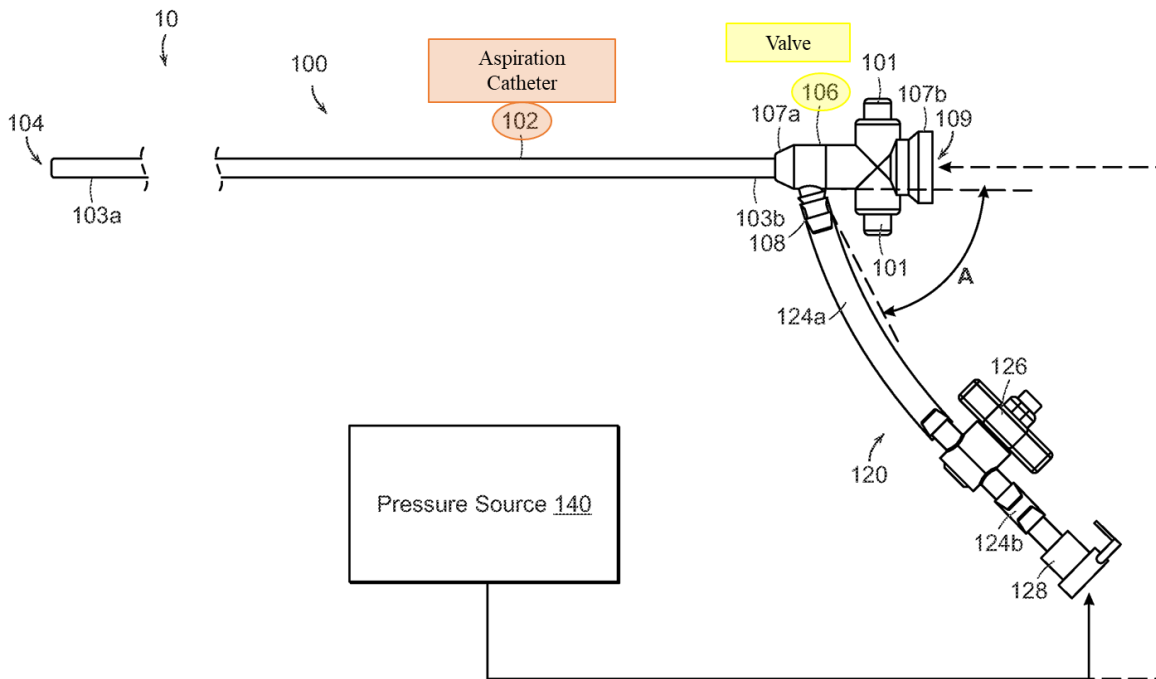

FIG. 1

(*Id.*, Fig. 1.)

The pressure source [red, below] is “configured to generate (e.g., form, create, charge, build-up, etc.) a vacuum (e.g., negative relative pressure) and store the vacuum for subsequent application to the catheter subsystem 100.” (*Id.*, 6:57-6:60.) “[T]he pressure source can be a pump (e.g., an electric pump coupled to a vacuum

chamber) while, in other embodiments, the pressure source can include one or more syringes” (*Id.*, 7:33-7:41.)

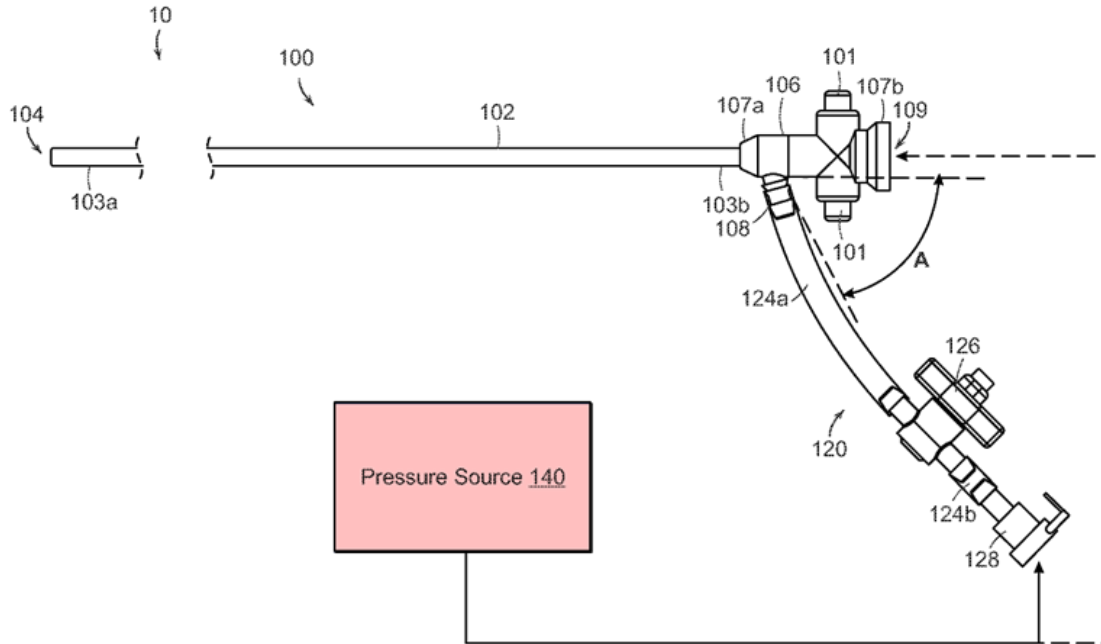

FIG. 1

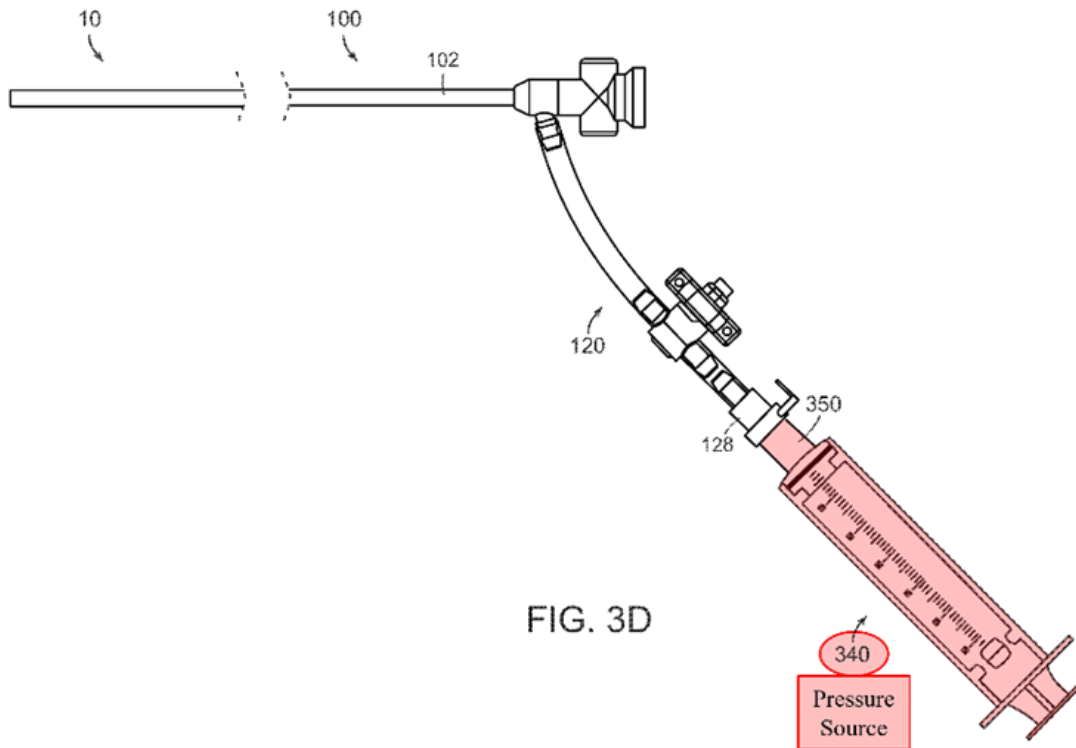

FIG. 3D

(*Id.*, Figs. 1, 3D.) The tubing subsystem “fluidly couples the catheter subsystem 100 to the pressure source 140.” (*Id.*, 6:6-6:7.) The tubing subsystem can include “one or more tubing sections 124,” at least one “fluid control device 126” such a stopcock, and at least one “connector 128 for fluidly coupling the tubing subsystem 120 to the pressure source 140 and/or other suitable components.” (*Id.*, 6:6-6:23.)

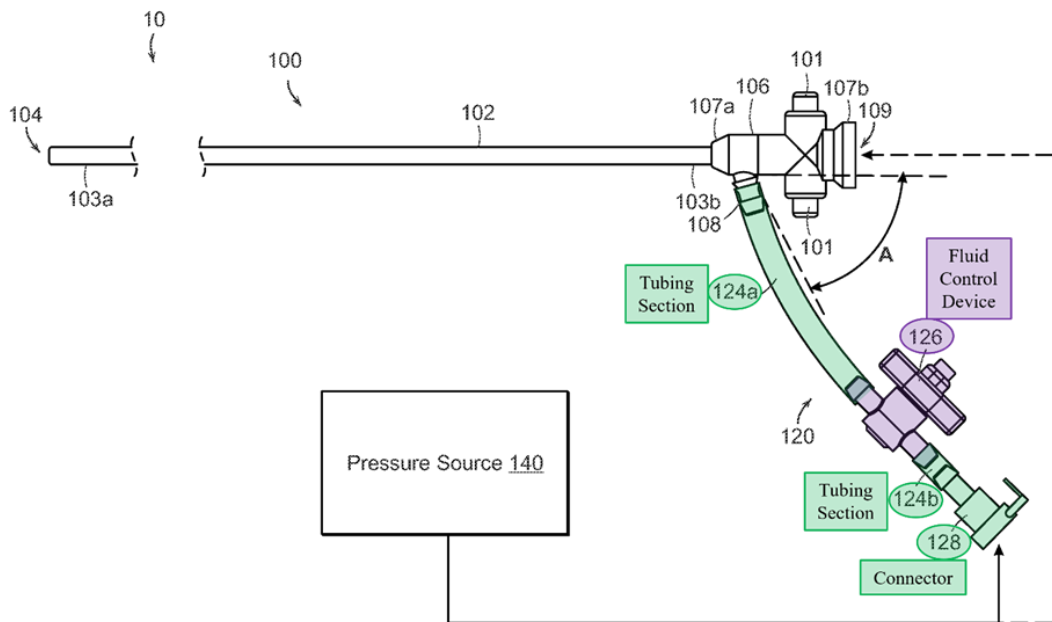
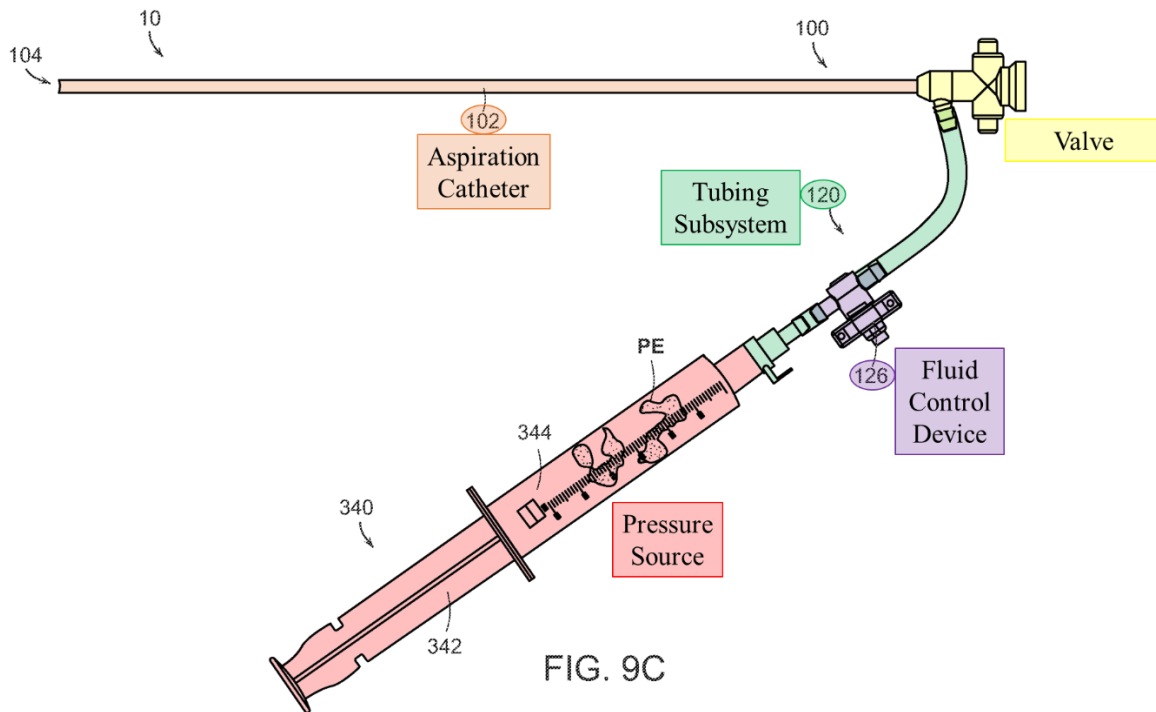

FIG. 1

(*Id.*, Fig. 1.)

During operation, a user “can first close the fluid control device 126 before activating the pressure source 140 to build up vacuum pressure within the pressure source 140 (e.g., a vacuum chamber of the pressure source 140).” (*Id.*, 6:62-6:66.) After pressure is generated, “the user can actuate (e.g., twist a handle of) the fluid control device 126 to open the fluid control device 126.” (*Id.*, 18:42-18:48.)

Opening the fluid control device 126 will “fluidly connect the pressure source 140 to the catheter subsystem 100 and thereby apply or release the vacuum stored in the pressure source 140 to the lumen 104 of the catheter 102.” (*Id.*, 7:1-7:8.)



(*Id.*, Fig. 9C.)

B. Prosecution History

The Examiner rejected the original Claims 1-6, 11-14, 16-18, and 20-22 as obvious in view of US 2018/0064453 A1 (“Garrison II”)¹ (Ex. 1032) in combination

¹ Garrison II is not in the same patent family as Garrison (Ex. 1006) and does not disclose the embodiments relied on in this Petition, including those in Figures 33-34. *Infra* §§VI.A.2.

with US 2005/0054995 A1 (“Barzell”) (Ex. 1033) and US 8535283 B2 (“Heaton”) (Ex. 1011). (Ex. 1002, 156-173.) The Examiner found that Garrison II disclosed every limitation of the independent claim except: (1) a filter positioned within the clot canister and configured to filter blood from the clot material and (2) a flow path extending from the lumen of the aspiration catheter, through the clot canister, and to the aspiration source. (*Id.*, 157-159.) The Examiner cited Barzell for a filter and Heaton for the flow path. (*Id.*, 159-160.)

Following the Examiner’s rejection, PO conducted an interview and filed an amendment cancelling all pending claims and adding new Claims 23-60 (which issued as Claims 1-38). (*Id.*, 98-100, 109-115.) During the interview, PO argued that a POSITA would not have found it obvious to treat PE or DVT with the aspiration system in Garrison II as modified by Barzell and Heaton. (*Id.*, 98-100, 116.) Relying on PO’s representations, the Examiner allowed the new claims, stating that a POSITA “would not have looked to use the Garrison device” to treat PE or DVT and that “the device of Garrison would not be combinable with the device of Garrison [SIC] to teach a method of treating [PE] or [DVT].” (*Id.*, 46-47.) The Examiner cited no evidentiary support but merely stated: “Garrison [II] specifically teaches the aspiration catheter being used for neurovascular procedures.” (*Id.*, 47.)

C. Earliest Possible Priority Date

The '333 patent claims priority to two provisional applications 62/554,931 and 62/718,269, both filed August 13, 2018, which is the earliest possible priority date for the '333 patent. (Ex. 1001.) Petitioner applies this earliest priority date in this Petition; however, Petitioner reserves its right to challenge the priority date of the '333 patent in subsequent proceedings.

III. LEVEL OF ORDINARY SKILL

A POSITA in August 2018 would have had an undergraduate degree in mechanical engineering or a related engineering discipline and 2-4 years of catheter design experience and, where necessary, would have consulted with a physician regarding the methods of treatment. (Ex. 1003, ¶35.)

IV. CLAIM CONSTRUCTION

The claim terms should receive their ordinary and customary meaning as understood by a POSITA at the time of filing and in accordance with the specification and the prosecution history. 37 C.F.R. §42.100(b); *see Phillips v. AWH Corp.*, 415 F.3d 1303 (Fed. Cir. 2005). However, “the specification may reveal a special definition given to a claim term by the patentee that differs from the meaning it would otherwise possess [and i]n such cases, the inventor's lexicography governs.” *Id.* at 1316.

Claims 11-12 and 30-31 of the '333 patent require a hemostasis valve having a “filament” and that decreasing/increasing tension on the filament opens/closes the valve. (Ex. 1001, Claims 11, 30.) The claim language does not provide a POSITA with guidance on the meaning of “filament,” other than reciting that altering tension on the filament provides or inhibits fluid access to the aspiration catheter.

Further, the '333 patent specification does not describe a hemostasis valve having a filament. In fact, the word “filament” does not appear in the '333 patent (other than in Claims 11-12 and 30-31). If this limitation has support in the '333 patent, the support must be incorporated by reference from another patent application describing a filament.² (*See* Ex. 1001, 5:56-61 (purporting to incorporate by reference “U.S. patent application Ser. No. 16/117,519 ... titled ‘HEMOSTASIS VALVES AND METHODS OF USE’”) (the “’519 application”, Ex. 1021.))

The '519 application identifies examples of “filaments” that expand the meaning of “filament” beyond the plain and ordinary meaning. The '519 application states, “the filament 150 can comprise one or several threads, lines, cords, rope, ribbon, flat wire, sheet, or tape.” (Ex. 1021, [0047].) The patent also states, “the filament can be made from a variety of materials including, for example, a polymer,

² Petitioner reserves its right to challenge in future proceedings whether PO has effectively incorporated the material into the '333 patent.

a synthetic, and/or a metal.” (*Id.*) The application further states, “the filament can comprise a single strand such as, for example, a monofilament, [or] the filament can comprise a plurality of strands that can be, for example, twisted, woven, grouped, and/or fused to form the filament.” (*Id.*) Additionally, the ’519 application explains that “the filament 150 can comprise multiple filaments and specifically, as shown in Figures 7 through 9, the filament 150 can comprise a first filament 150-A and a second filament 150-B.” (*Id.*, [0065].)

Given the above descriptions, a POSITA would have understood the claim term “filament” to mean at least “one or more threads, lines, cords, ropes, ribbons, flat wires, sheets, or tapes.” (Ex. 1003, ¶¶52-72.)

Petitioner does not believe any other terms in the challenged claims require construction to resolve the patentability issues herein.

V. STATEMENT OF RELIEF REQUESTED

A. IPR Grounds

Petitioner asserts the following grounds of unpatentability:

IPR Petition – Patent 11,969,333
Imperative Care, Inc. v. Inari Medical Inc.

Ground		Reference(s)	35 U.S.C.	Challenged Claims
1	A	Laub + Garrison	§103	1-10, 13-29, 33-38
	B	Laub + Garrison + Goff	§103	6-8, 17, 25-27, 36
	C	Laub + Garrison + Schaffer	§103	11-12, 30-31
	D	Laub + Garrison + Schaffer + Hartley	§103	11-12, 30-31
2	A	Aklog + Garrison	§103	1-10, 13-29, 32-38
	B	Aklog + Garrison + Goff	§103	6-8, 17, 25-27, 36
	C	Aklog + Garrison + Schaffer	§103	11-12, 30-31
	D	Aklog + Garrison + Schaffer + Hartley	§103	11-12, 30-31
3	A	Garrison + Laub	§103	1-10, 13-29, 32-38
	B	Garrison + Laub + Goff	§103	6-8, 17, 25-27, 36
	C	Garrison + Laub + Schaffer	§103	11-12, 30-31
	D	Garrison + Laub + Schaffer + Hartley	§103	11-12, 30-31
4	A	Garrison + Aklog	§103	1-10, 13-29, 32-38
	B	Garrison + Aklog + Goff	§103	6-8, 17, 25-27, 36
	C	Garrison + Aklog + Schaffer	§103	11-12, 30-31
	D	Garrison + Aklog + Schaffer + Hartley	§103	11-12, 30-31

The Petition is supported by the expert declaration of Troy Thornton.
(Ex.1003.)

B. The Asserted References Are Prior Art

The following references are prior art under at least 35 U.S.C. §102(a)(1):

- (1) Aklog (Ex. 1005) issued May 27, 2014;
- (2) Laub (Ex. 1012) published on February 16, 2017;
- (3) Garrison (Ex. 1006) published June 25, 2015;
- (4) Goff (Ex. 1007) published November 23, 2006;
- (5) Hartley (Ex. 1008) published June 26, 2003; and
- (6) Schaffer (Ex. 1013) published on December 4, 2003.

C. The Asserted References Are Analogous Art

The asserted references are analogous art that is usable in an obviousness combination. *Unwired Planet, LLC v. Google Inc.*, 841 F.3d 995, 1000 (Fed. Cir. 2016). The references are from the same field as the '333 patent, e.g., devices for aspirating unwanted material from a patient. (Ex. 1003, ¶26.) The references are also pertinent to the problem the inventor was focused on, e.g., removing clots, emboli, and thrombi from a patient's blood vessel. (*Id.*; see also Ex. 1001, 2:45-46 (“there exists a need for improved systems and methods for embolic extraction”).) Accordingly, a POSITA is presumed to have been aware of these references and the

teachings may be combined to support an obviousness rejection. *In re Nilssen*, 851 F.2d 1401, 1403 (Fed. Cir. 1988).

VI. GROUNDS 1A, 2A, 3A, 4A – LAUB, AKLOG, AND GARRISON

A. Claim 1

Claim 1 is rendered obvious by Laub or Aklog in view of Garrison or Garrison in view of Laub or Aklog. (Ex. 1003, ¶¶74-118.)

1. Preamble

If the preamble is limiting, Laub and Aklog disclose or render obvious a “method of treating a pulmonary embolism within a vasculature of a patient.” (Ex. 1003, ¶¶75-77.) Garrison in view of Laub or Aklog also renders this limitation obvious. (*Id.*, ¶¶78-95.)

a. Laub

Laub discloses an aspiration system “to remove clots from patients suffering from or at risk of pulmonary embolisms.” (Ex. 1012, [0005].) Laub’s system includes “an aspiration catheter 200 configured to be inserted into the patient’s body (e.g., into a vein or artery) and aspirate blood and other material (e.g., thrombi).” (*Id.*, [0024], Fig. 1A.)

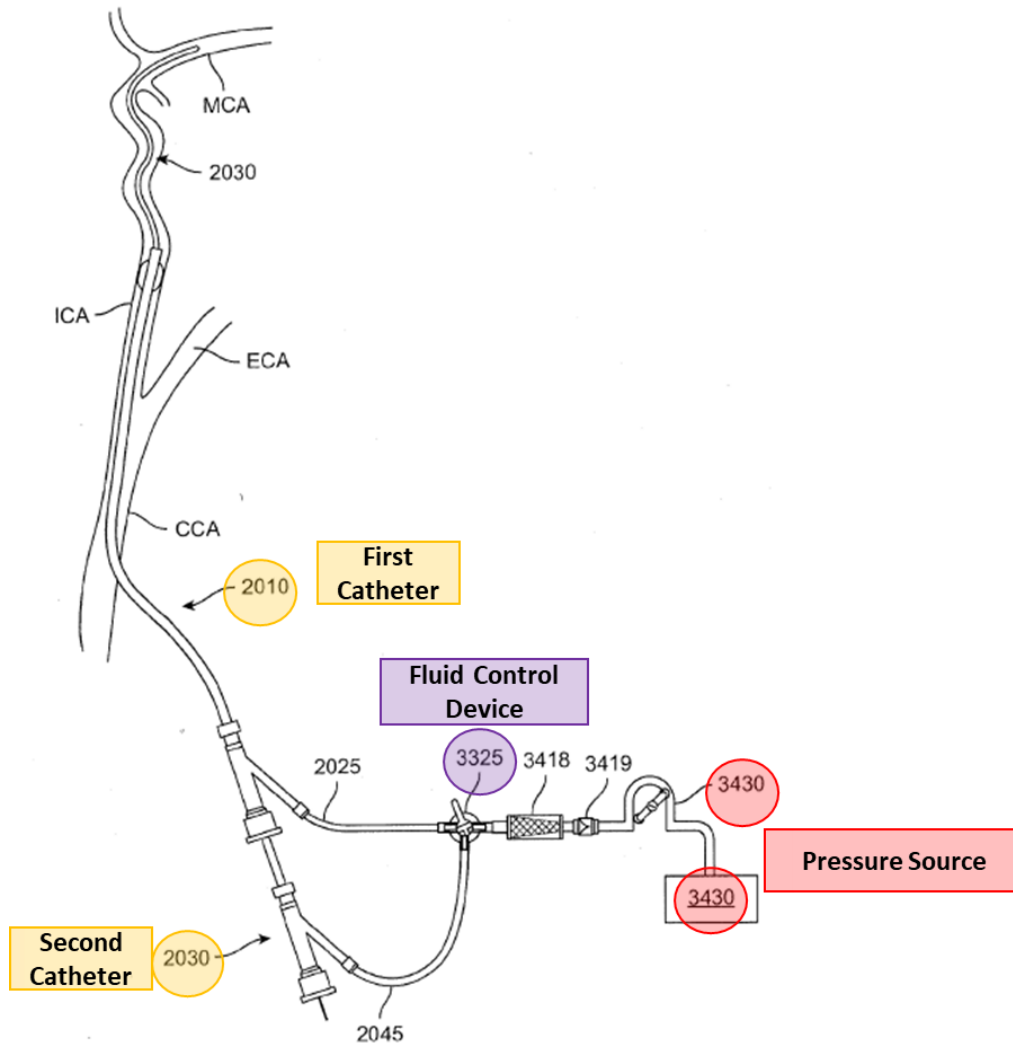

FIG. 34

(*Id.*, Fig. 34; *see also id.*, [0131]-[0134].) While Garrison focuses on the “treatment of cerebral occlusions,” a POSITA would have found it obvious to use, or optimize, Garrison’s clot treatment system to treat PE based on Laub or Aklog. (Ex. 1006, [0002]; Ex. 1003, ¶¶78-95.)

A POSITA would have been motivated to use, or optimize, Garrison’s system to treat PE based on Aklog and Laub because “[t]he general procedure for aspirating a blood clot from a blood vessel is similar regardless of whether the physician is

removing the clot from the brain, lungs, legs, or any other party of the body.” (Ex. 1022, ¶21.) Garrison, Laub, and Aklog, for example, all disclose inserting the catheter system through a small incision in the leg to access the transfemoral vein or artery. (Ex. 1006, [0048]; Ex. 1012, [0024]-[0026]; Ex. 1005, 15:30-34; *see also* Ex. 1001, 17:7-8 (“Access to the pulmonary vessels can be achieve through the patient’s vasculature, for example, via the femoral vein.”)).

The physician then initiates suction by withdrawing a syringe or turning on a pump to aspirate the clot. (Ex. 1022, ¶22.) Garrison, Laub, and Aklog all disclose using a pump, in addition to other devices, to generate suction. (Ex. 1005, 5:37-41; Ex. 1006, [0134]; Ex. 1012, abstract.) These references also confirm that aspiration systems for the brain and other parts of the vasculature, including the legs (DVT) and lungs (PE), use the same general components. In each reference, the aspiration system includes a pressure source connected by medical tubing to a filter, which is then connected to an aspiration catheter. (Ex. 1005, Figs. 6-7; Ex. 1006, Figs. 33-34; Ex. 1012, Fig. 1A; Ex. 1022, ¶24.)

The similarities between the systems would have further motivated POSITAs to use Garrison’s system to treat clots in other parts of the vasculature, including PEs and DVTs, and given POSITAs a reasonable expectation of success. (Ex. 1003, ¶79, 90; Ex. 1022, ¶¶26-39 (describing use of smaller catheters to treat PE/DVT).) In fact, using Garrison’s system to treat PEs and DVTs would have been nothing more

than the predictable use of prior art elements according to their established functions.

KSR, 550 U.S. 398, 416 (2007).

Garrison

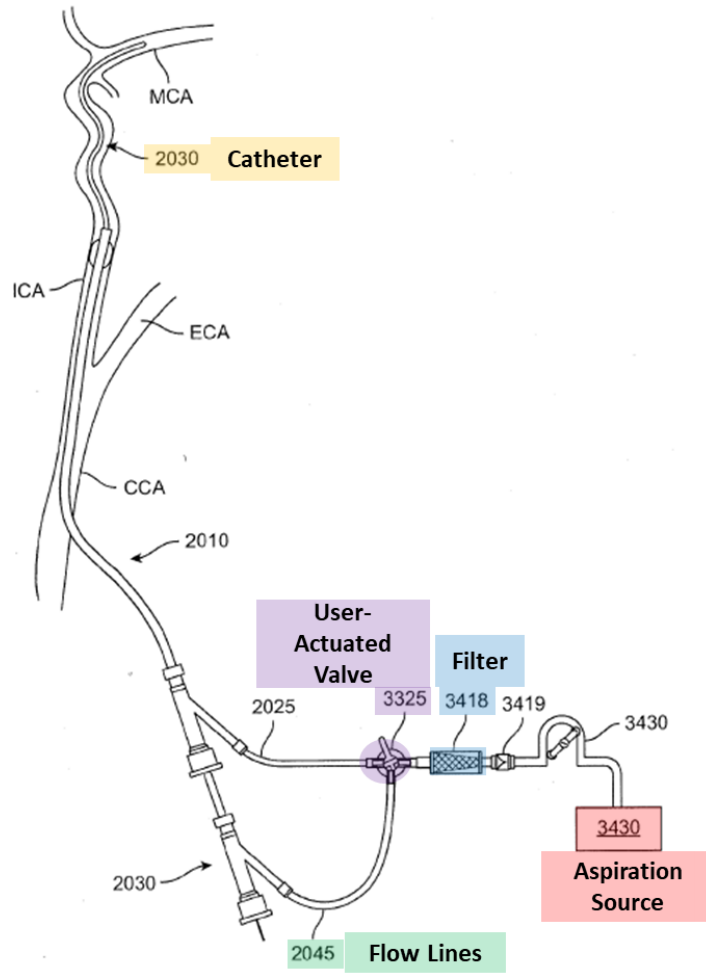
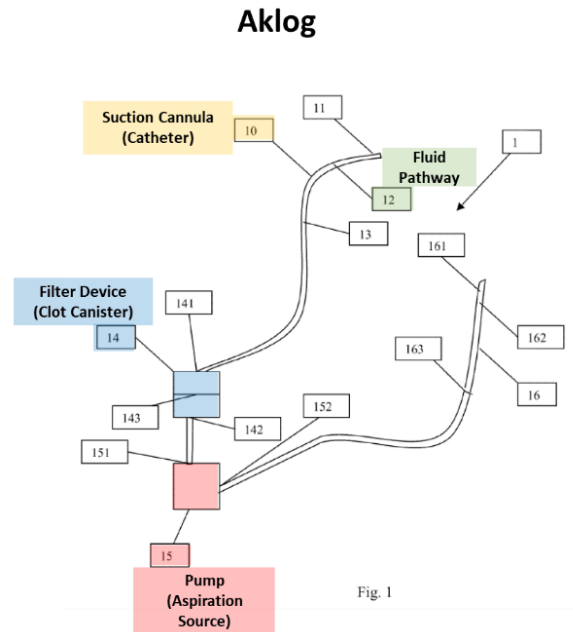
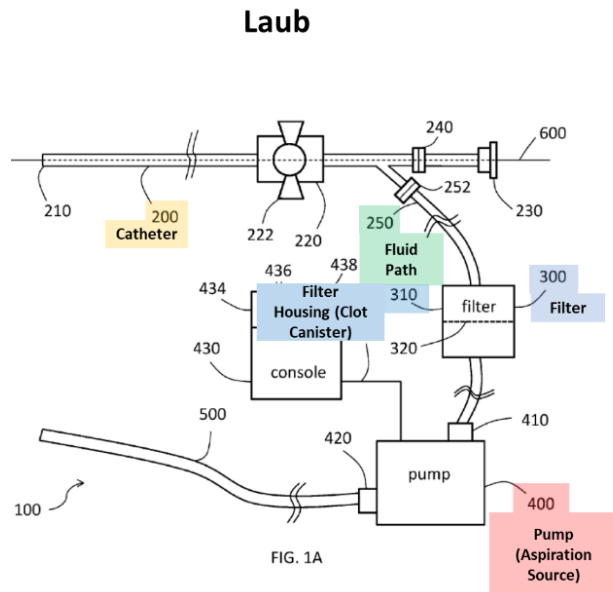

FIG. 34



Not surprisingly, POSITAs routinely used aspiration catheters designed for one part of the vasculature to treat different parts of the vasculature. (See Ex. 1022, ¶¶25 (describing use of peripheral systems for cerebral applications).) And the prior art patents confirm that using the same aspiration catheter system in many parts of the vasculature was common practice. (See Ex. 1003, ¶¶85-87 (citing Ex. 1020, describing catheters for cerebral clots and PE).)

Further, prior to 2018, POSITAs routinely upsized catheters originally designed for one part of the vasculature for another. (Ex. 1022, ¶¶26-37; Ex. 1003, ¶¶80, 83.) For example, Penumbra, one of the market leaders in thrombectomy, and Petitioner both adapted their aspiration catheters designed to remove cerebral clots to treat other types of clots, including DVT and PE. (Ex. 1022, ¶¶30-32.)

In fact, even the '333 patent acknowledges that aspiration systems could be used across different parts of the vasculature. The '333 patent states, “Although many of the embodiments are described below with respect to devices, systems, and methods for treating a *pulmonary embolism*, other applications and other embodiments in addition to those described herein are within the scope of the technology (e.g., intravascular procedures other than the treatment of emboli, *intravascular procedures for treating cerebral embolism*, intravascular procedures for treating deep vein thrombosis (DVT), etc.” (Ex. 1001, 4:51-58 (emphasis added).) The '333 patent does not identify any special reasons why its aspiration catheters can be used interchangeability across different parts of the vasculature while other aspiration catheters could not. Thus, this common practice of optimizing aspiration systems designed for one part of the vasculature for another would have given POSITAs additional comfort that Garrison’s system could be used and optimized to treat PEs. (Ex. 1003, ¶¶83-84.)

A POSITA would have also been motivated to use and optimize Garrison’s system to treat PEs and DVTs, and reasonably expected success in doing so, based on the similarities between cerebral clots and PEs and DVTs. (Ex. 1022, ¶¶38-41; Ex. 1003, 83.) The references cited herein demonstrate the close relationship between clots and embolisms across the vasculature.

For example, Aklog explains, “DVT causes harm by (1) obstructing drainage of venous blood from the legs ... and (2) serving as a reservoir for blood clot to travel to other parts of the body including the heart, lungs (*pulmonary embolism*) and across a opening between the chambers of the heart (patent foramen ovale) to the *brain (stroke)*, abdominal organs or extremities.” (Ex. 1005, 2:13-19 (emphasis added).) Thus, a DVT can become a PE or cerebral embolism. (See Ex. 1022, ¶¶38-41 (describing similarity of clots).) Consequently, POSITAs developing treatments for clots in one part of the body naturally consulted innovations for treating clots in other parts of the body. Laub and Aklog explain that PEs are harmful clots that can block blood flow to the lungs and cause death. (Ex. 1012, [0004]; Ex. 1005, 2:20-32.) Given the similarity in clots and the known danger of PE, POSITAs would have found it obvious to try using Garrison’s aspiration system to treat PEs and DVTs and, to the extent necessary, would have found it obvious to optimize the system to treat PEs and DVTs. (Ex. 1003, ¶83.)

Moreover, Garrison’s catheters are appropriately sized to treat PEs and DVTs without modification. Garrison describes catheters ranging from 6-10F. (Ex. 1006 (Garrison) at [0063].) Penumbra, one of the current market leaders in aspiration thrombectomy, sells aspiration catheters of 7F and 12F for removing PEs and DVTs. (Ex. 1022, ¶39.) Likewise, Petitioner sells its Prodigy Thrombectomy system in sizes ranging from 5F-8F to treat the peripheral vasculature. (*Id.*)

Further, Garrison explains that cerebral occlusions are more difficult to treat than clots in larger vessels due to “special access challenges.” (Ex. 1006, [0042]; *see also* Ex. 1022, ¶¶33-37 (describing challenges of treating neurovascular clots).) Garrison explains that the “access route is long, often tortuous and may contain stenosis plaque material in the aortic arch and carotid and brachiocephalic vessel origins, presenting a risk of embolic complications during the access portion of the procedure.” (*Id.*) Additionally, “the cerebral vessels are usually more delicate and prone to perforation than coronary or other peripheral vasculature.” (*Id.*)

To address these challenges, Garrison describes catheters with small diameters and enhanced flexibility. (*Id.*; *see also id.*, [0109] (describing a “very flexible, kink resistant and collapse resistant catheter”).) Accordingly, while an aspiration catheter designed to treat PEs or DVTs may not be appropriate for a cerebral clot, a catheter designed to treat cerebral clots *can* treat PEs and DVT. (Ex. 1003, ¶80; Ex. 1022, ¶¶33-37.) For these additional reasons, POSITAs would have been motivated to use, and found it obvious to try, Garrison’s system to treat PEs and DVTs, and reasonably expected success in doing so. (*Id.*)

Further, if Garrison’s system required some optimization to more effectively treat PEs and DVTs, POSITAs would have possessed the necessary skills to perform such optimizations. (Ex. 1003, ¶¶80, 91.) These optimizations could have included upsizing Garrison’s aspiration catheters (and related components), such as by using

Laub’s catheters measuring 16F or 20F, optimizing the catheter’s flexibility and torque characteristics, and potentially adjusting the suction force. (*Id.*)

Aklog confirms that POSITAs possessed the knowledge make these routine optimizations. While Aklog primarily describes treatments for medium and large vessels, Aklog explains “that the systems and methods, hereinafter disclosed, can be scaled and adapted for use within smaller vessels within the body, if desired.” Ex. 1005 (Aklog) at 7:43-46. Thus, Aklog presumes that POSITAs possessed the requisite knowledge to make these simple optimizations. (Ex. 1003, ¶¶80, 91.)

Garrison also discloses several sheath and catheter sizes for its system, further demonstrating that selecting the appropriate catheter size was routine. Ex. 1006 (Garrison) at [0063] (describing 6 and 8 French sheaths); [0070] (describing 10 French sheaths). POSITAs would have reasonably expected success in incorporating the larger catheters described in Laub and Aklog into Garrison’s system because this type of routine upsizing was common and because Laub and Aklog describe larger catheters as being effective for treating PE and DVT. (Ex. 1003, ¶¶80, 83-88, 91, 93-95; Ex. 1022, ¶¶30-37 (describing real-world upsizing of neuro catheters for PE and DVT).)

Further, Garrison specifically suggests combining its aspiration system with components from aspiration systems for treating other parts of the vasculature. For example, Garrison incorporates by reference components from devices for treating

the coronary, cerebral, cardiac, and peripheral vasculature. (Ex. 1006, [0070], [0144] (citing Exs. 1014, 1018); Ex. 1003, ¶¶84-85.) The combination of Garrison’s catheter system with Laub or Aklog’s larger catheter components would have involved the simple substitution of one known element (Garrison’s catheter) for another (Laub’s or Aklog’s catheters) to obtain the predictable result of aspirating blood clots. *KSR*, 550 U.S. at 401. Further, to the extent other components in Garrison’s system would need to be upsized, like the valves, such upsizing was customary. Thus, the teachings in Garrison would have further motivated POSITAs to use or optimize Garrison’s system to treat PEs and DVTs and would have given POSITAs a reasonable expectation of success in doing so. (Ex. 1003, ¶¶84-85.)

Finally, Garrison already accounts for one challenge POSITAs encountered when moving from smaller to larger aspiration catheters – a larger catheter “may aspirate an unacceptable volume of blood, resulting in excessive fluid loss and/or shock in the patient.” (Ex. 1005, 7:23-26.) Aklog explains that the solution to using larger catheters is to reinfuse the “fluid removed (i.e., suctioned or aspirated) from the site of interest back into a patient, in order to minimize fluid loss within the patient.” (*Id.*, 7:47-52.) Garrison addresses this challenge by including an “aspiration pump device 3250 which is configured not to harm blood cells and which may be configured to return blood to the central venous system in real time during the procedure, so there is no reservoir in which the blood remains static.” (Ex. 1006,

[0135]; *id.* at [0136]; *see also id.* at [0140], Fig. 38 (describing blood return variations). This blood return solution would have reinforced a POSITA’s reasonable expectation of success in upsizing Garrisons’ catheters to aspirate PEs/DVTs. (Ex. 1003, ¶¶82, 92; *see also* Ex. 1022, ¶41 (describing real-world blood-loss solutions).)

For these reasons, a POSITA would have found it obvious to use, or optimize, Garrison’s aspiration system treat PE based on Laub or Aklog and the knowledge of a POSITA. (Ex. 1003, ¶¶78-95.)

2. Advancing Aspiration Catheter

Clam 1 next recites: “advancing an aspiration catheter at least partially through the vasculature of the patient such that a distal end portion of the aspiration catheter is positioned proximate to the pulmonary embolism, wherein a lumen of the aspiration catheter is fluidly coupled along a fluid path to a clot canister and an aspiration source proximal to the clot canister.” Laub and Aklog disclose these limitations. (Ex. 1003, ¶¶97-100.) Additionally, Garrison combined with Laub or Aklog renders these limitations obvious. (*Id.*, ¶¶101-102.)

a. Laub

Laub’s aspiration system treats PEs using an aspiration catheter 200 [orange], a fluid path 250 [green] that places the catheter in fluid communication with a pump 400 [red], and a filter [blue] positioned between the catheter and pump:

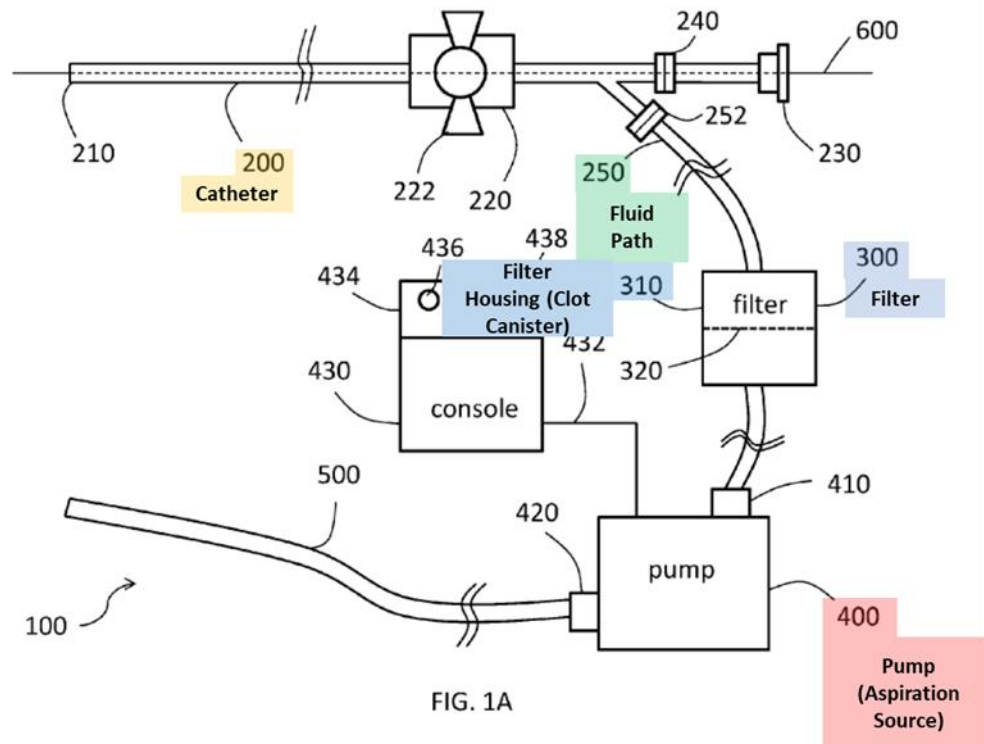
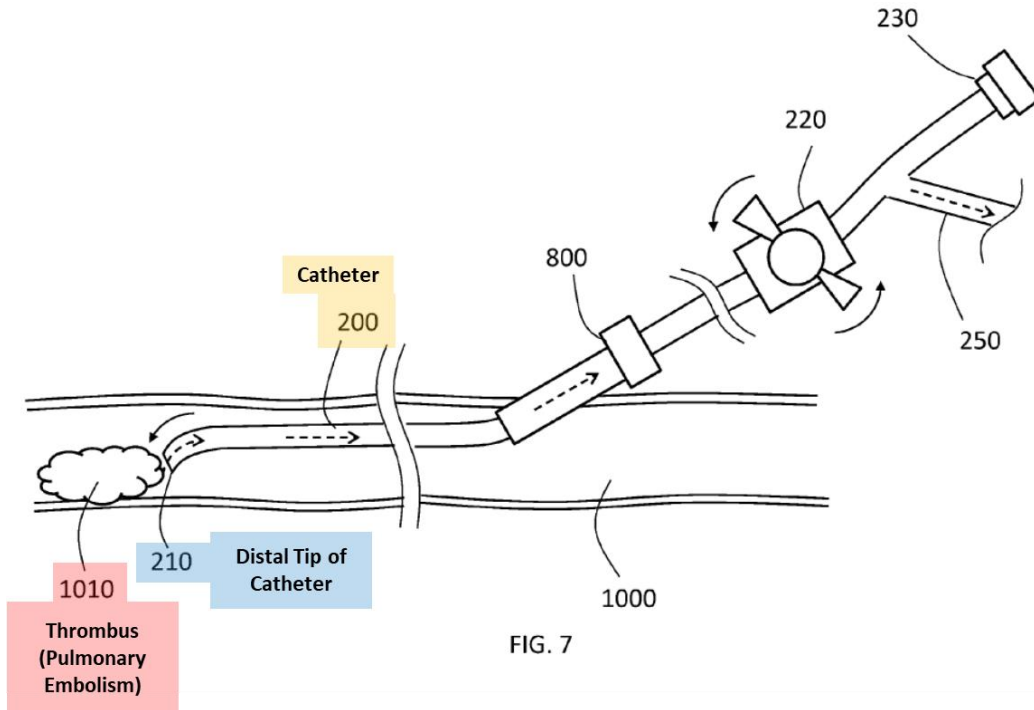

FIG. 1A

(Ex. 1012, [0024], [0039]-[0040], Fig. 1A.) Laub’s filter 300 includes a housing 310 and “is configured to trap solid material received through aspiration catheter 200.” (*Id.*, [0040].) Laub explains that blood is passed through a separator 320 in the filter, while solid materials (i.e., clots) are collected within the housing. (*Id.*) Thus, Laub’s filter housing 310 is a “clot canister.” (*Id.*; Ex. 1003, ¶97.) As illustrated above, the aspiration catheter is fluidly coupled along a fluid path 250 to the clot canister and a pump that is proximal to the filter. (*Id.*)

Laub discloses that its system may be advanced through the vasculature of a patient to remove PEs. (Ex. 1012, [0005].) As shown below, Laub discloses that

the distal tip 210 of the catheter 200 is positioned proximate to the clot/thrombus before removal:



(*Id.*, [0046], Fig. 7.)

b. Aklog

Aklog discloses an aspiration system for treating PEs that includes a suction cannula 10 [orange] with a fluid pathway 12 [green] that fluidly connects the cannula to a filter [blue] and a pump [red] that is proximal to the filter:

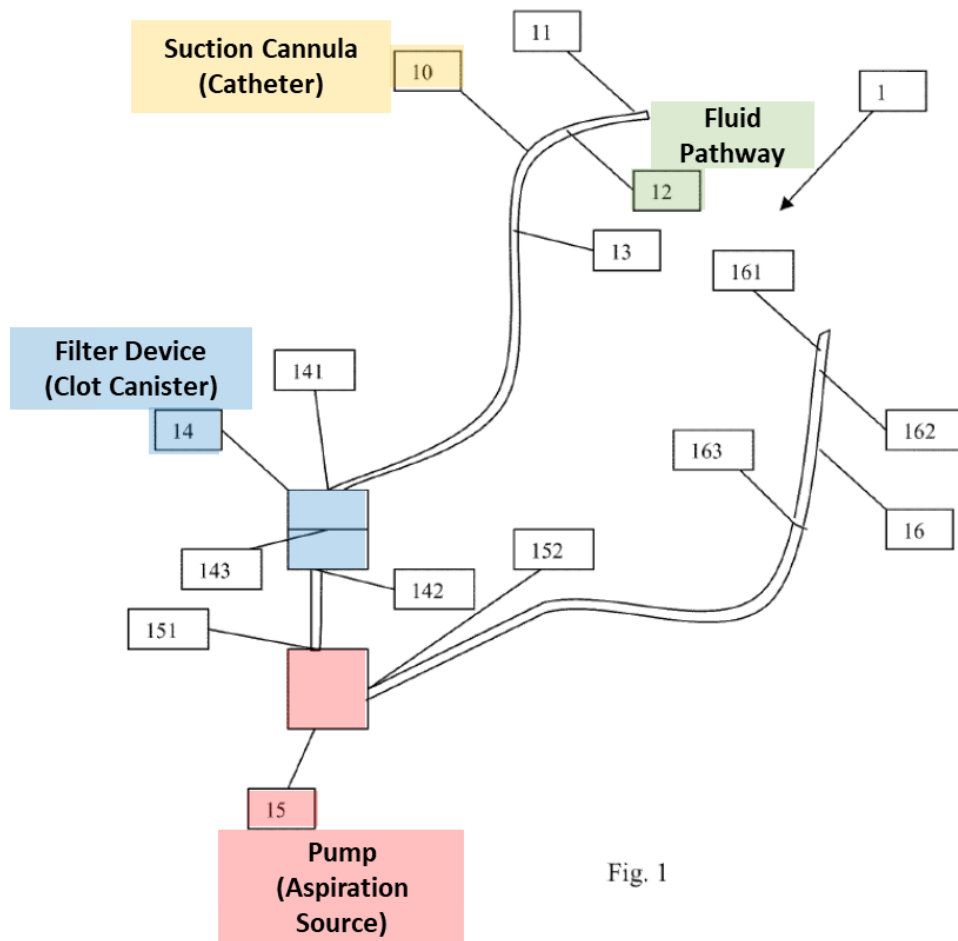

Fig. 1

(Ex. 1005, 7:47-64, 11:24-35, 11:62-12:14, Fig. 1.) Aklog’s filter device 14 includes a permeable sheet or other material that allows aspirated blood to flow through the filter while trapping solid material (i.e., clots). (*Id.*, 11:24-61, 16:4-8.) Aklog’s filter device 14 is therefore a “clot canister.” (Ex. 1003, ¶99.) Aklog discloses the method of inserting the suction cannula into the patient’s vasculature and advancing the cannula’s distal end proximate to the clot material:

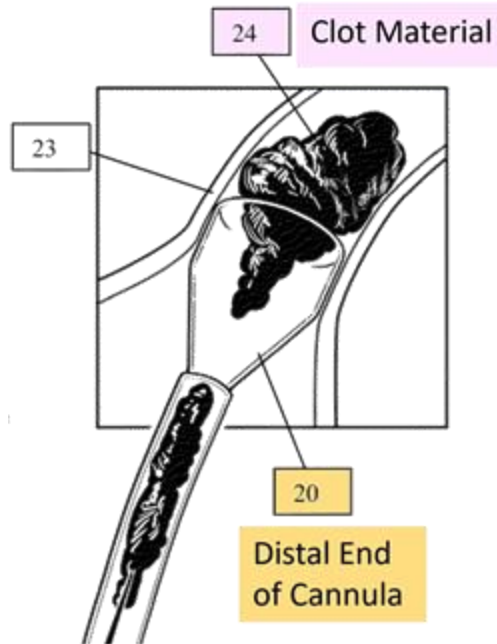

Fig. 2C

(Ex. 1005, 5:28-41, 11:62-65, 13:64-14:2, 16:27-53, 16:66-17:4, Figs. 2C, 2D, 2H.)

c. **Garrison and Laub or Aklog**

Like Laub and Aklog, Garrison's system includes an aspiration catheter [orange] that is fluidly coupled along a fluid path [green dots] to a filter/clot canister [blue] and an aspiration source [red] proximal to the clot canister:

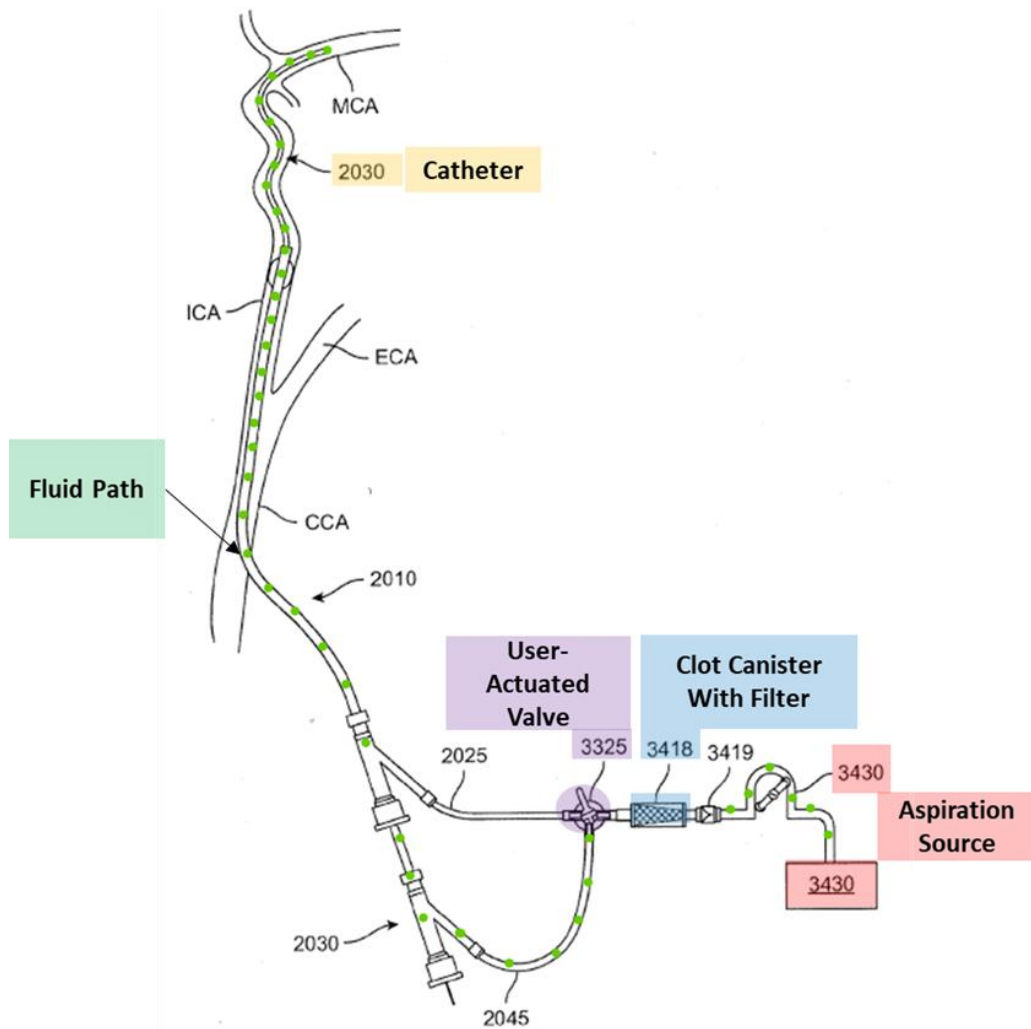

FIG. 34

(*Id.*, Fig. 34, [0131]-[0134].) Garrison discloses advancing its aspiration catheter through the patient’s vasculature until the distal end of the catheter is proximate to the clot material. (*Id.*, [0134].)

A POSITA would have found it obvious to use or optimize Garrison’s aspiration system to treat PE based on Laub or Aklog and the knowledge of a POSITA as explained above. (*Supra* §VI.A.1.) When Garrison’s system is used to

treat PE, the distal end of Garrison’s catheter would be advanced proximate to the PE (the target clot). (Ex. 1003, ¶102.)

3. Generating Vacuum Pressure With Valve In First Position

Claim 1 next recites: “generating vacuum pressure within the clot canister via the aspiration source while a valve positioned along the fluid path between the aspiration catheter and the clot canister is in a first position that inhibits fluid flow along the fluid path from the lumen of the aspiration catheter to the clot canister.” Garrison discloses this limitation and Laub or Aklog combined with Garrison render this limitation obvious. (Ex. 1003, ¶¶103-111.)

a. Garrison

Garrison’s system includes a valve 3325 [purple] along the fluid path between the filter [blue] and the aspiration catheter [orange]:

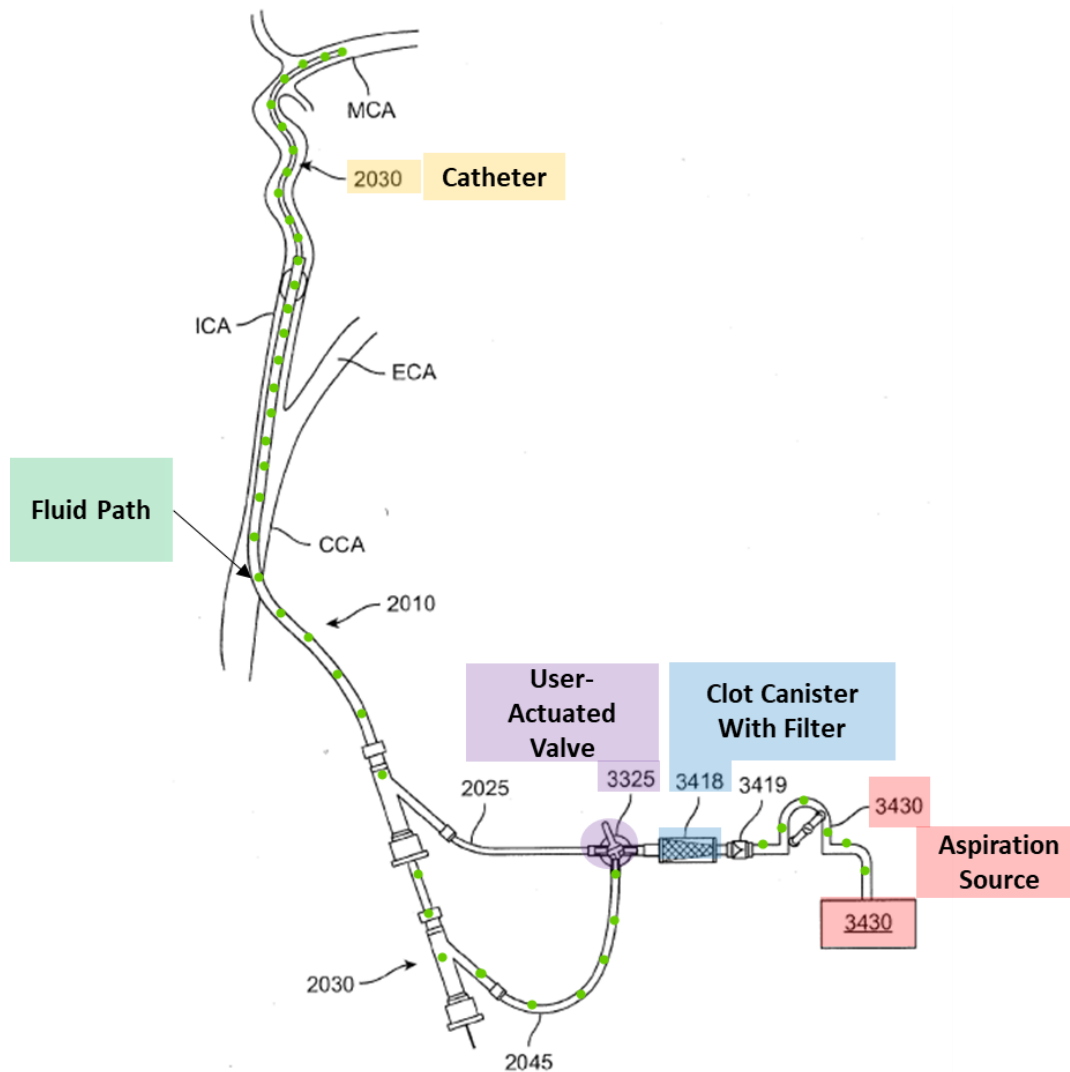

FIG. 34

(*Id.*, Fig. 34, [0131]-[0134].) Garrison discloses that the “valve 3325 controls which device is connected to the aspiration source 3430.” (*Id.*) “The valve may be a 3-way or 4-way stopcock” and “enable[s] one device, the other device, both devices, or neither device to be connected to the aspiration source at any given time.” (*Id.*) The valve can also “be a flow controller with a simple actuation which selects the configuration as described above.” (*Id.*)

Garrison further describes an embodiment in which “a locking syringe (for example a VacLok Syringe) is attached to the flow controller and the plunger is pulled back into a locked position by the user while the connection to the flow line is closed prior to the thrombectomy step of the procedure.” (Ex. 1006, [0134]; *see also* Ex. 1022, ¶23 (describing use of similar procedure since the early 2010s).) Once the catheter is positioned proximate the thrombus, “the user may open the connection to the aspiration syringe” to “enable the maximum level of aspiration in a rapid fashion.” (Ex. 1006, [0134] (emphasis added).) Because the valve (e.g., stopcock 3325) is distal to the filter, the vacuum pressure builds up in the filter canister via the pressure source. (*Id.*, Fig. 34; Ex. 1003, ¶105.) While this embodiment specifically includes a flow controller, Garrison discloses replacing the controller with a stopcock. (Ex. 1006, [0132].)

b. Laub or Aklog and Garrison

A POSITA would have been motivated to incorporate Garrison’s valve 3325 and method of generating pressure while the valve is closed into Laub’s or Aklog’s aspiration systems. (Ex. 1003, ¶¶106, 109.) POSITAs would have been motivated to supplement Laub or Aklog based on Garrison’s description that manipulation of the valve “enable[s] the maximum level of aspiration in a rapid fashion with one user.” (Ex. 1006, [0134].) A POSITA would have recognized that Garrison’s valve could improve Laub’s or Aklog’s temporary aspiration power to aspirate PE’s more

quickly, making Laub’s and Aklog’s systems safer and more effective. (Ex. 1003, ¶¶106, 109.) Further, combining Garrison’s valve with Laub’s or Aklog’s aspiration systems would have merely entailed combining known elements (Garrison’s valve and Laub’s/Aklog’s system) according to known methods (positioning the valve between the catheter and filter along the flow path) to yield the predictable result of aspirating clots from the patient’s vasculature. *KSR*, 550 U.S. at 416; (Ex. 1003, ¶¶106, 109.)

POSITAs would have reasonably expected success in incorporating Garrison’s valve and aspiration technique into Laub’s or Aklog’s system. (Ex. 1003, ¶¶107, 110.) Laub, Aklog, and Garrison describe similar systems that are inserted into a patient’s vasculature in the same way to perform the same function. (*Supra* §VI.A.1; Ex. 1006, [0134].) Further, a stopcock is a simple mechanical structure that POSITAs would have used regularly in 2018. (Ex. 1003, ¶¶107, 110.) A POSITA would have had extensive experience connecting/disconnecting stopcocks from medical lines and systems. (*Id.*)

Also, Laub’s system already includes a connector 252, which connects the aspiration catheter 200 to the fluid path 250 and “may allow detachment of fluid path 250 from aspiration catheter 200”:

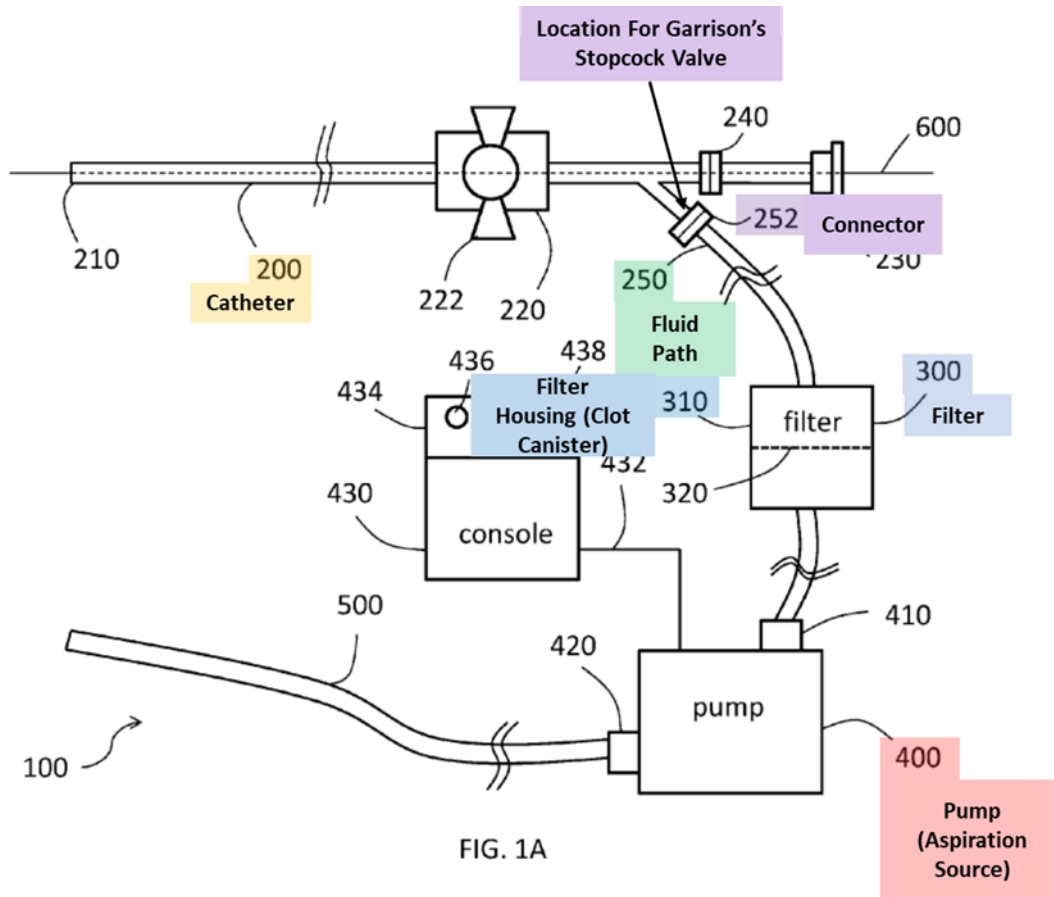
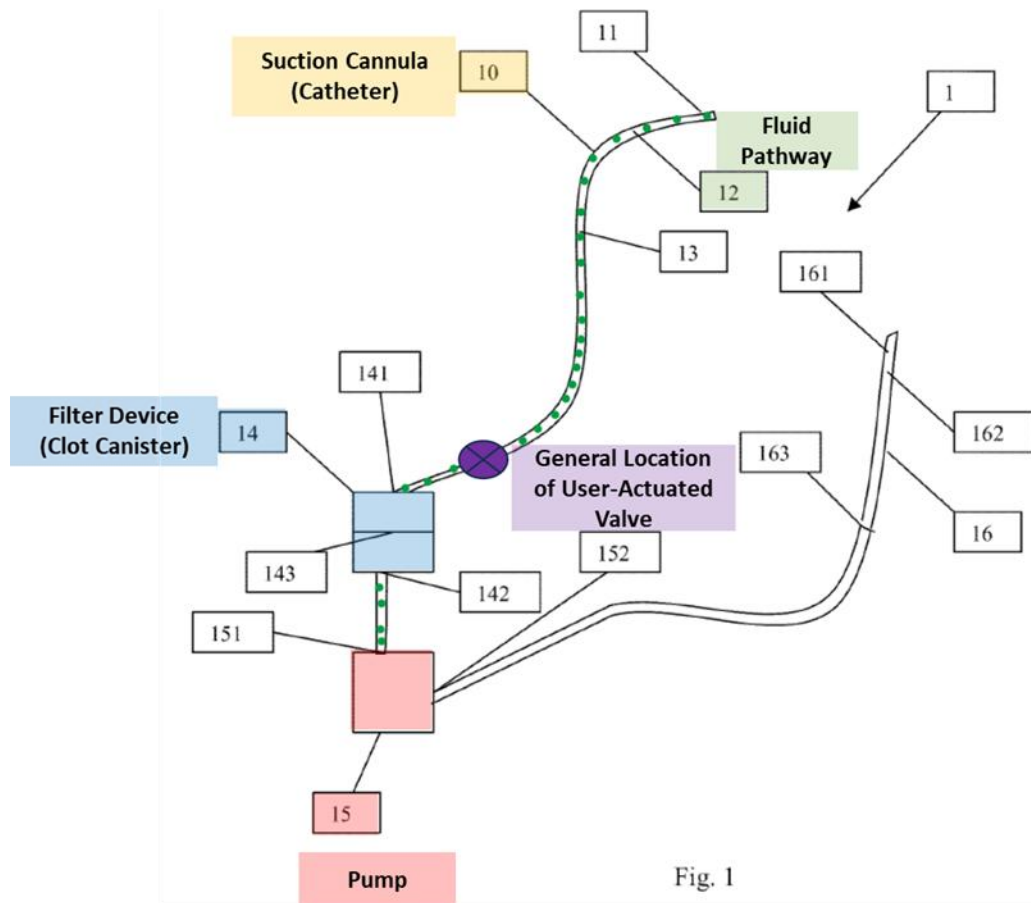

FIG. 1A

(Ex. 1012, [0039], Fig. 1.) A POSITA would have understood that a stopcock could be incorporated into Laub's device at the connector to help control the fluid flow. (Ex. 1003, ¶108.) This is particularly true in view of Garrison, which describes placing a stopcock at a similar location within Garrison's aspiration system for the purpose of controlling fluid flow. (*Id.*) A POSITA would have reasonably expected success in incorporating the stopcock at this location because Laub already includes the necessary connectors to incorporate the valve and Garrison discloses that such an arrangement is beneficial for generating rapid suction. (*Id.*)

A POSITA would have also been motivated to, and reasonably expected success in, incorporating Garrison’s valve into Aklog’s flow path between the catheter and filter/clot canister for the same reasons:



(Ex. 1005, Fig. 1; Ex. 1003, ¶111.) Such a modification would have involved nothing more than attaching the stopcock between a piece of tubing extending from the filter and a piece of tubing extending to the suction cannula. (Ex. 1003, ¶111.)

4. Moving The Valve From First To Second Position

Claim 1 next recites: “moving the valve from the first position to a second position thereby applying the vacuum pressure to the lumen of the aspiration catheter

such that at least a portion of the pulmonary embolism and blood are aspirated into the clot canister, wherein in the second position the valve permits fluid flow along the fluid path from the lumen of the aspiration catheter to the clot canister.” Garrison discloses this limitation and Laub or Aklog combined with Garrison render this limitation obvious. (Ex. 1003, ¶¶48, 112-114.)

Garrison describes an embodiment in which “a locking syringe (for example a VacLok Syringe) is attached to the flow controller and the plunger is pulled back into a locked position by the user while the connection to the flow line is closed prior to the thrombectomy step of the procedure.” (Ex. 1006, [0134]; *see also* Ex. 1022, ¶23 (describing use of this procedure since the early 2010s).) Once the catheter is proximate the clot, “the user may open the connection to the aspiration syringe” to “enable the maximum level of aspiration in a rapid fashion.” (Ex. 1006, [0134].)

Thus, Garrison discloses a method of aspirating clot material that involves moving the valve from a first, closed position to a second, open position to apply vacuum pressure to the lumen of an aspiration catheter. (Ex. 1003, ¶114.) When Garrison’s system is used to treat PE, or when Garrison’s valve is incorporated into the systems in Laub or Aklog, moving the valve to the second position would cause at least a portion of the PE and blood to be aspirated into the clot canister. (*Id.*)

5. Filter

Claim 1 finally recites: “wherein the clot canister includes a filter configured to filter the blood from the portion of the pulmonary embolism.” Garrison, Laub, and Aklog disclose this limitation for the reasons explained previously. (*Supra* §VI.A.2.)

B. Claim 2

Claim 2 recites the “method of claim 1 wherein advancing the aspiration catheter comprises inserting a catheter having a size of 16 French or greater through the vasculature.” Laub or Aklog combined with Garrison, and Garrison combined with Laub or Aklog renders Claim 2 obvious. (Ex. 1003, ¶¶119-124.)

1. Laub

Laub discloses this limitation because Laub states, “[i]n some embodiments, aspiration catheter 200 has a French size of at least 16 Fr.” (Ex. 1012, [0028].)

2. Aklog

Aklog discloses, “[c]annula 10 of the present invention may be of any sufficient size, so long as it can be accommodated within a predetermined vessel, such as a medium to large size blood vessel.” (Ex. 1005, 11:12-15.) Aklog further discloses that the “size of cannula 10 may also be determined by the size of the undesirable material to be removed, so long as the undesirable material can be removed substantially en bloc without significant fragmentation” and that the

cannula may have a sufficient size “to remove at least 10 cm³ of undesirable material substantially en bloc.” (*Id.*, 11:15-20.) As demonstrated by Laub and other prior art references, the pulmonary vasculature could accommodate aspiration catheters having a size of 16 Fr. or 20 Fr. or greater and could remove PE en bloc. (Ex. 1003, ¶122; *see* Ex. 1049, 241 (disclosing 26 Fr. Angiovac catheter used to treat PE).) Accordingly, POSITAs would have been motivated to use a catheter of at least 16 Fr with Aklog’s system, particularly to treat PE, and they would have reasonably expected success in doing so. (Ex. 1003, ¶123.)

3. Garrison and Laub or Aklog

Laub and Aklog disclose or render obvious aspirating PE with catheters having a size 16 Fr. or greater. (*Supra* §§VI.B.1-2.) POSITAs would have been motivated to use the catheters of Laub or Aklog with Garrison’s system to treat PE for the reasons explained in Claim 1. (*Supra* §§VI.A.1.)

C. Claim 3

Claim 3 recites the “method of claim 1 wherein advancing the aspiration catheter comprises inserting a catheter having a size of 20 French or greater through the vasculature.” Laub or Aklog combined with Garrison, and Garrison combined with Laub or Aklog renders Claim 3 obvious. (Ex. 1003, ¶¶125-128.)

1. Laub

Laub discloses this limitation because Laub states, “[i]n some embodiments, aspiration catheter 200 has a French size of at least 20 Fr.” (Ex. 1012, [0028].)

2. Aklog

POSITAs would have been motivated to use a catheter of at least 20 Fr with Aklog’s system to treat PE, and they would have reasonably expected success in doing so, for the same reasons they would have used a 16 Fr catheter. (*Supra*, §VI.B.2.)

3. Garrison and Laub or Aklog

Laub and Aklog disclose or render obvious aspirating PE with catheters having a size 20 Fr. or greater. (*Supra* §§VI.C.1-2.) POSITAs would have been motivated to use the catheters of Laub or Aklog with Garrison’s system to treat PE for the reasons explained in Claim 1. (*Supra* §§VI.A.1.)

D. Claim 4

Claim 4 recites the “method of claim 1 wherein advancing the aspiration catheter includes advancing the aspiration catheter such that a distal end portion of the aspiration catheter is positioned proximate to the pulmonary embolism within a pulmonary artery of the patient.” Laub or Aklog combined with Garrison, and Garrison combined with Laub or Aklog renders Claim 4 obvious for the reasons provided in Claim 1. (*Supra*, §VI.A.2.)

E. Claim 5

Claim 5 recites the “method of claim 1 wherein the method further comprises: receiving the filtered blood through a fluid outlet of the clot canister; and reintroducing the filtered blood into the vasculature of the patient.” Laub or Aklog combined with Garrison, and Garrison combined with Laub or Aklog renders Claim 5 obvious. (Ex. 1003, ¶¶131-137.)

1. Laub

Laub’s aspiration system includes a “return catheter 500 for returning aspirated blood to the patient.” (Ex. 1012, [0024].) Laub also has a filter 300 “positioned anywhere in fluid communication between the aspiration catheter 200 and return catheter 500.”

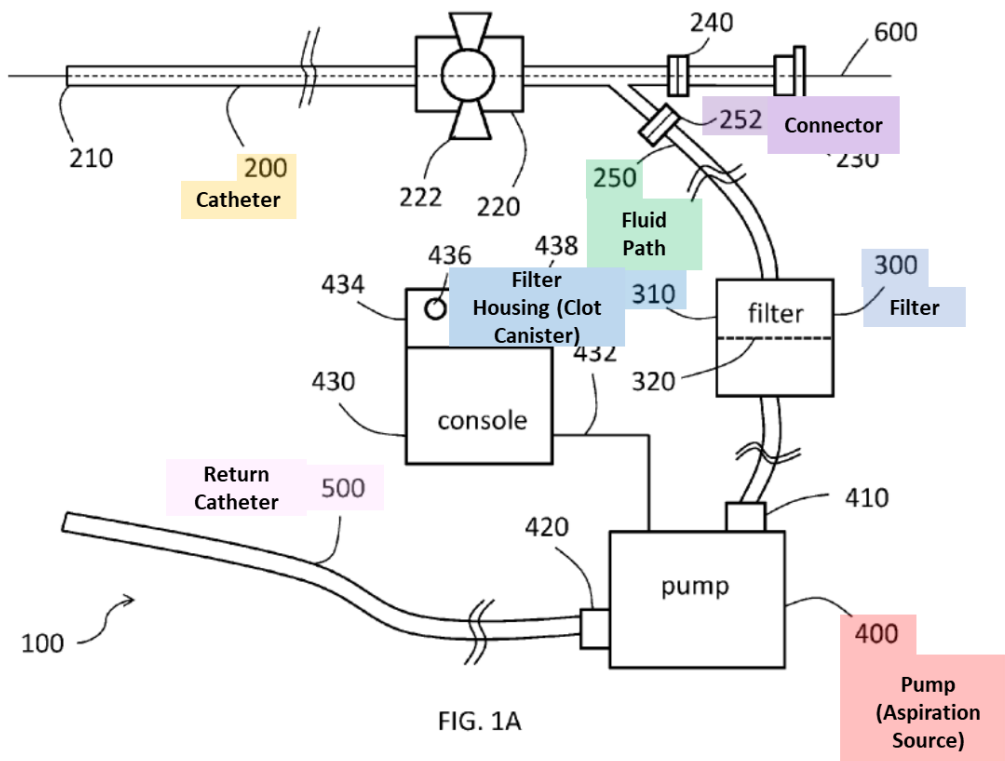

(*Id.*, [0024], Fig. 1.) Laub’s filter 300 includes a “housing 310 [i.e., clot canister] containing at least one separator 320 configured to separate the solid materials from the aspirated blood.” (*Id.*, [0040].) Laub discloses that “[b]lood which passes through separator 320 may then be suctioned through the remainder of fluid path 250 and into pump 400 through inlet port 410.” (*Id.*) Laub discloses that the filtered blood suctioned into the pump is then reintroduced into the patient’s vasculature via return catheter 500.” (*Id.*, [0045].)

2. Aklog

Aklog’s aspiration system includes a filter device 14 having an inlet 141 “through which fluid removed from the site of interest along with the captured undesirable material can be directed from cannula 10” and an outlet 142 “through which filtered fluid from within device 14 may be directed downstream of system 1.” (Ex. 1005, 11:24-31, Fig. 7.) Aklog further discloses that its system includes a reinfusion cannula 16 “designed to permit filtered fluid, directed from filter device 14 by way of pump 15, to be reinfused back into a patient at a desired site.” (*Id.*, 12:29-31.)

3. Garrison

Garrison describes an “aspiration pump device 3250 which is configured not to harm blood cells and which may be configured to return blood to the central venous system in real time during the procedure, so there is no reservoir in which

the blood remains static.” (Ex. 1006, [0136]-[0137]; *see also id.*, [0140]-[142], Fig. 38.) Garrison discloses that the device 3250 “may be connected to either or both the arterial access device 2010 and the catheter 2030.” (*Id.*, [0136].)

F. Claim 9

Claim 9 recites the “method of claim 1 wherein the valve comprises a lever, and wherein moving the valve from the first position to the second position includes rotating the lever.” Laub or Aklog combined with Garrison, and Garrison combined with Laub or Aklog renders Claim 9 obvious. (Ex. 1003, ¶¶138-139.)

Garrison discloses a valve 3325 fluidly connected to the aspiration source that “may be a 3-way or 4-way stopcock” that “enable[s] one device, the other device, both devices, or neither device to be connected to the aspiration source at any given time.” (Ex. 1006, [0132].) A POSITA would have recognized that a 3-way or 4-way stopcock valve includes a lever used to adjust the position of the valve, as illustrated in Garrison:

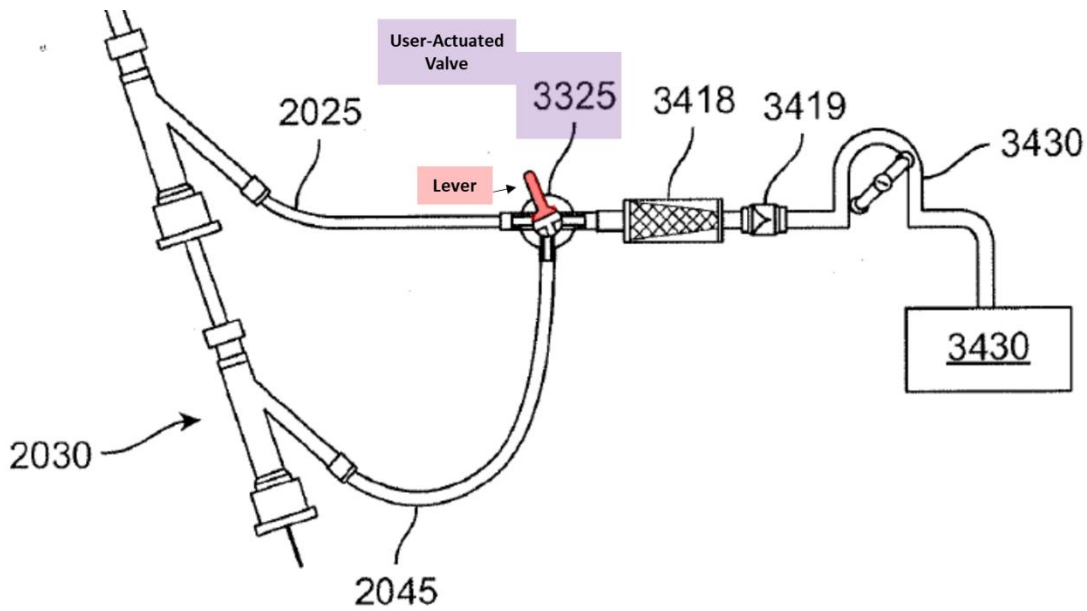

FIG. 34

(*Id.*, [0132], Fig. 34; Ex. 1003, ¶139.) Stopcock valves like those disclosed in Garrison were commonly used in medical devices before 2018, and a POSITA would have been familiar with their use and construction. (*See, e.g.*, Ex. 1046, Fig. 1; Ex. 1003, ¶139.)

G. Claim 10

Claim 10 recites the “method of claim 1 wherein the method further comprises selectively providing fluid access to the lumen of the aspiration catheter via a hemostasis valve fluidly coupled to the aspiration catheter.” Laub or Aklog combined with Garrison, and Garrison combined with Laub or Aklog renders Claim 10 obvious. (Ex. 1003, ¶¶140-145.)

1. Garrison

Garrison discloses an aspiration catheter 2030 having a “proximal hub 2065” or “proximal adaptor” and explains that “a separate hemostasis valve may be attached to proximal hub 2065” or “the hemostasis valve may be integral to the catheter proximal adaptor”:

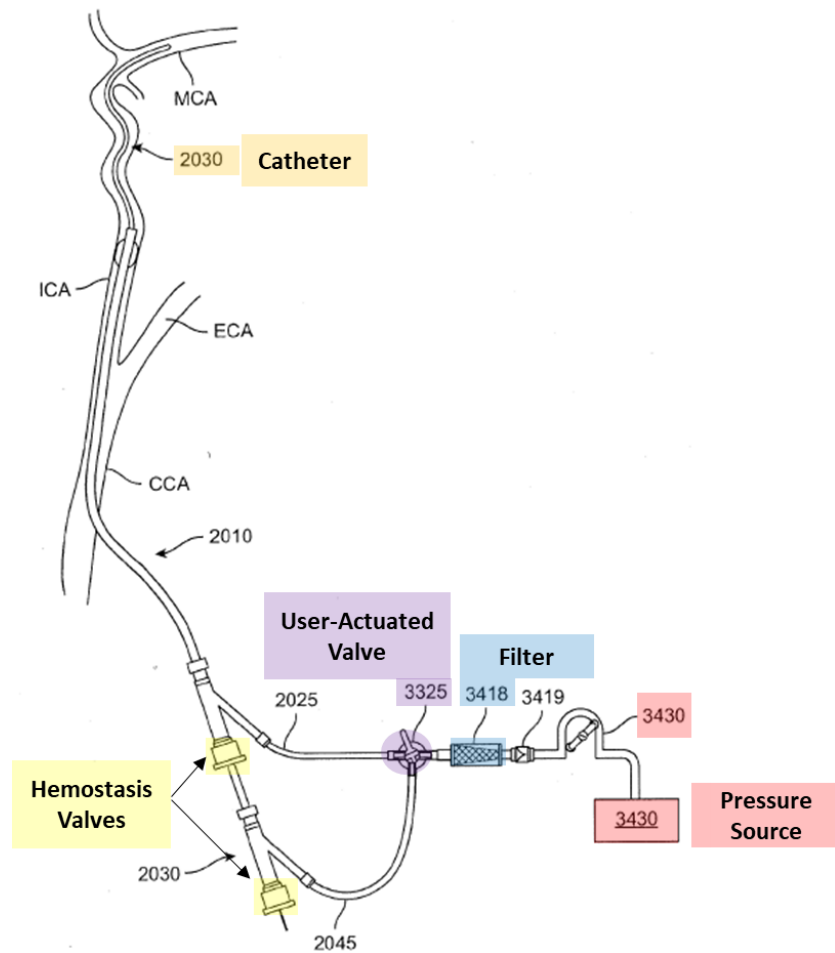
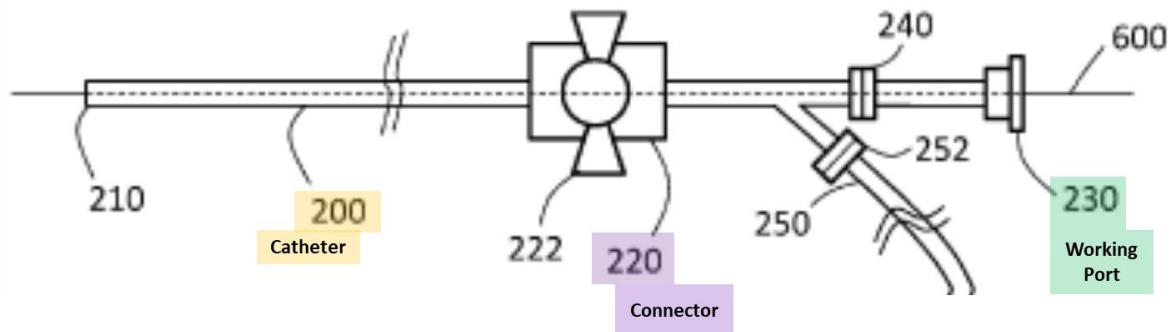

FIG. 34

(Ex. 1006, [0098], Fig. 34.) Garrison’s hemostasis valve allows “introduction of devices such as a microcatheter, guide wire, or thrombectomy device while preventing or minimizing blood loss during the procedure.” (*Id.*)

2. Laub and Garrison

Laub’s aspiration system may include a working port 230 extending proximally from the controller 220 that “allows insertion of instruments into and/or through the lumen of aspiration catheter 200”:



(Ex. 1012, [0035], Fig. 1A (excerpt).) The working port may be “configured to provide a fluid tight seal around stylet 700 or other device inserted through working port 230, for example, so as to prevent leakage of blood out of working port 230 during use,” such as by using a Tuohy-Borst adapter. (*Id.*, [0036].) Laub further discloses that the “working port 230 may include a valve to close working port 230 when not in use.” (*Id.*) A POSITA would have recognized that Laub is describing a hemostasis valve. (Ex. 1003, ¶143.)

If Laub does not disclose this limitation, a POSITA would have been motivated to use a hemostasis valve in Laub’s working port 230 in view of Garrison. (*Id.*, ¶144.) A POSITA would have been motivated to use Garrison’s hemostasis valve in Laub’s working port 230 to create a fluid tight seal around tools inserted into the aspiration catheter to prevent or minimize blood loss during the procedure.

(*Id.*) Laub and Garrison disclose similarly configured aspiration systems, and Laub’s working port is intended to perform the function of a hemostasis valve. Therefore, a POSITA would have reasonably expected success in incorporating Garrison’s hemostasis valve into Laub’s working port 230. (*Id.*; *supra* §VI.A.1.)

3. Aklog and Garrison

Aklog discloses that its aspiration system may include “a port 51, as shown in FIG. 5, located at the proximal end 13 of cannula 10” that allows for introduction of additional devices, including guidewires and catheters, into the lumen of the aspiration catheter. (Ex. 1005, 11:4-7.) A POSITA would have been motivated to include Garrison’s hemostasis valve in Aklog’s port 51 to prevent or minimize blood from leaking through the port 51 when a device such as a guidewire or catheter is inserted through the port into the aspiration catheter. (Ex. 1003, ¶145.) A POSITA would have reasonably expected success in doing so due to the similarities between the systems and simplicity of the valves. (*Supra* §VI.G.2.)

H. Claim 14

Claim 14 recites the “method of claim 1 wherein the method further comprises: positioning a clot treatment device within the lumen of the aspiration catheter; and engaging a portion of the pulmonary embolism with the clot treatment device thereby disrupting the pulmonary embolism.” Laub or Aklog combined with

Garrison, and Garrison combined with Laub or Aklog renders Claim 14 obvious.
(Ex. 1003, ¶¶146-151.)

1. Laub

Laub’s system includes a working port 230 that “allows insertion of instruments into and/or through the lumen of aspiration catheter 200.” (Ex. 1012, [0035].) The “other devices” can include “other wires, balloon catheters, diagnostic catheters, baskets, optical fibers, thrombolysis tools, needles, cutters, biopsy devices, and other surgical implements known in the art.” (*Id.*) Laub’s “thrombolysis tools, needles, cutters, biopsy devices, and other surgical implements” constitute “clot treatment devices.” (Ex. 1003, ¶147.) A POSITA would have also recognized that using these clot treatment devices would have involved advancing the device through the lumen of the aspiration catheter to the PE and then engaging the embolism with the treatment device to disrupt the embolism. (*Id.*)

2. Aklog

Aklog discloses that the lumen of its aspiration catheter can “accommodate other devices, such as other catheters or surgical instruments” and explains that “[f]or example, a device may be inserted and advanced along lumen 41 through the distal end 11 of suction cannula 10 to dislodge the undesirable material.” (Ex. 1005, 10:55-60.) Aklog further discloses that when suction alone is insufficient to dislodge the clot material, a “balloon catheter can be inserted through the side port of suction

cannula 71, advanced past a distal end of cannula 71, and past the adherent undesirable material.” (*Id.*, 18:38-43.) The balloon is then inflated and withdrawn into the aspiration catheter while suction is applied, which “can act to drag the undesirable material into the cannula 71.” (*Id.*, 43-48.) Thus, Aklog discloses positioning a clot treatment device through the aspiration catheter and engaging a PE with the treatment device to disrupt the embolism. (Ex. 1003, ¶148.)

3. Garrison

Garrison’s aspiration catheter can be used with “[m]echanical thrombectomy devices [such as] coil-tipped retrievers, stent retrievers, expandable cages, wire or filament loops, graspers, brushes, or the like.” (Ex. 1006, [0144].) Garrison also discloses thrombus disruption devices used to “break up the clot” material as it is being aspirated into the catheter during the procedure. (*Id.*, [0125].) Garrison explains that “[i]f the thrombus is too large or too strongly embedded into the vasculature such that it is not possible to remove the occlusion via aspiration alone, further steps are taken to remove the occlusion” such as deploying a “thrombectomy device 15 ... through the arterial access device to remove the clot.” (*Id.*, [0165].)

Garrison therefore discloses positioning a clot treatment device within the lumen of the aspiration catheter and engaging a portion of the clot material with the clot treatment device. (Ex. 1003, ¶151.) A POSITA would have been motivated to

use Garrison’s system to treat PE in view of Laub or Aklog for the reasons explained for claim 1. (*Supra* §VI.A.1.)

I. Claim 15

Claim 15 recites the “method of claim 1 wherein the aspiration source is an electric pump.” Laub or Aklog combined with Garrison, and Garrison combined with Laub or Aklog renders Claim 15 obvious. (Ex. 1003, ¶¶152-156.)

1. Laub

Laub’s system includes a pump 400 which may be a centrifugal pump, a rotary pump, peristaltic pump, roller pump, or other form of pump known in the art. (Ex. 1012, [0041].) The pump 400 “may be controlled by a console” connected to the pump via either a “hard-wired electrical pathway” or a wireless connection. (*Id.*) POSITAs would have therefore understood Laub to disclose an electric pump. (Ex. 1003, ¶153.)

2. Aklog

Aklog’s system can include a pump 15 “designed to generate negative pressure ... to create a necessary suction force through cannula 10 to pull any undesirable material from the site of interest.” (Ex. 1005, 11:62-65.) The pump 15 “may be any commercially available pump, including those for medical applications and those capable of pumping fluids, such as blood.” (*Id.*, 11:62-12:14.) Thus,

POSITAs would have understood Aklog to disclose an electric pump. (Ex. 1003, ¶154.)

3. Garrison

Garrison discloses aspiration “may be done manually, with an aspiration pump, or with another aspiration source, or via the flow controller as described above.” (Ex. 1006, [0165].) Garrison also discloses that “[e]xamples of devices for active reverse flow are a syringe or other manual aspiration device, or an aspiration pump.” (*Id.*, [0072]; *see also id.*, [0134].) POSITAs would have therefore understood Garrison to disclose an electric pump. (Ex. 1003, ¶155.)

J. Claim 16

Claim 16 recites the “method of claim 1 wherein the clot canister has a first volume, and wherein the aspiration source has a second volume greater than the first volume.” Laub or Aklog combined with Garrison, and Garrison combined with Laub or Aklog renders Claim 16 obvious. (Ex. 1003, ¶¶156-161.)

1. Garrison

Figure 33 of Garrison discloses a clot canister 3418 having a first volume smaller than a second volume of the aspiration source:

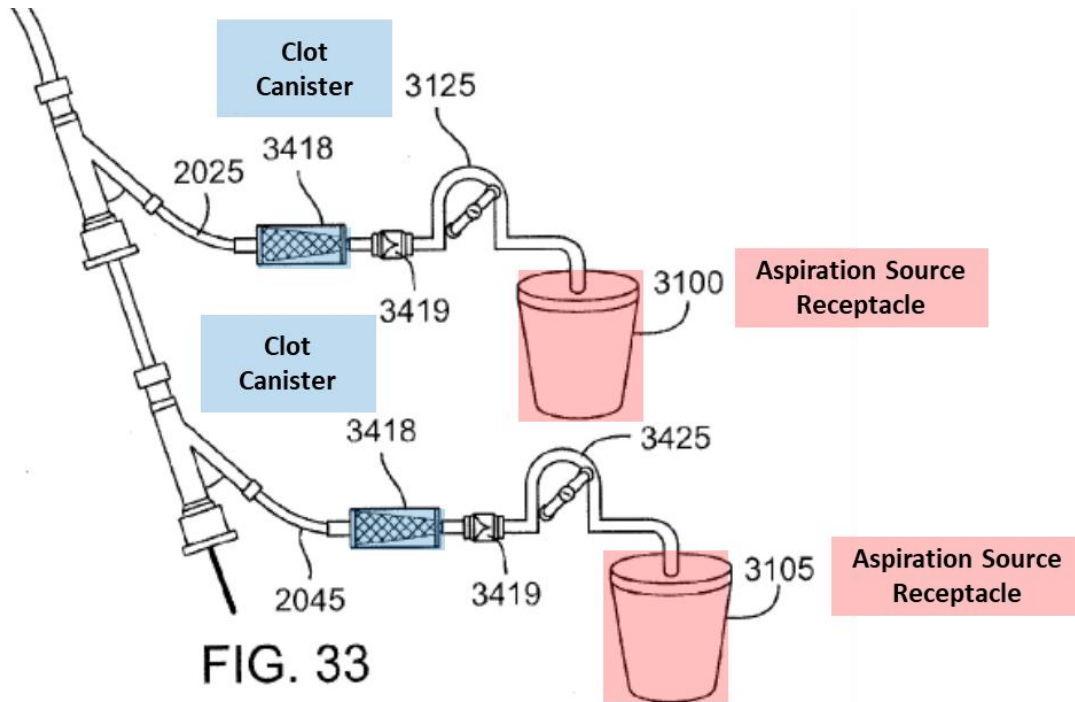

(Ex. 1006, [0131]-[132], Fig. 33.) While Garrison’s Figure 33 illustrates the aspiration source to include a peristaltic pump, Garrison broadly discloses that the aspiration source may be “a syringe or other manual aspiration device, or an aspiration pump.” (*Id.*, [0072].) Thus, POSITAs would have recognized that Garrison’s aspiration source is not limited to peristaltic pumps, and includes other aspiration pumps known in the art, such as the electric pump disclosed in Brady, which includes a volume for collecting the aspirated blood:

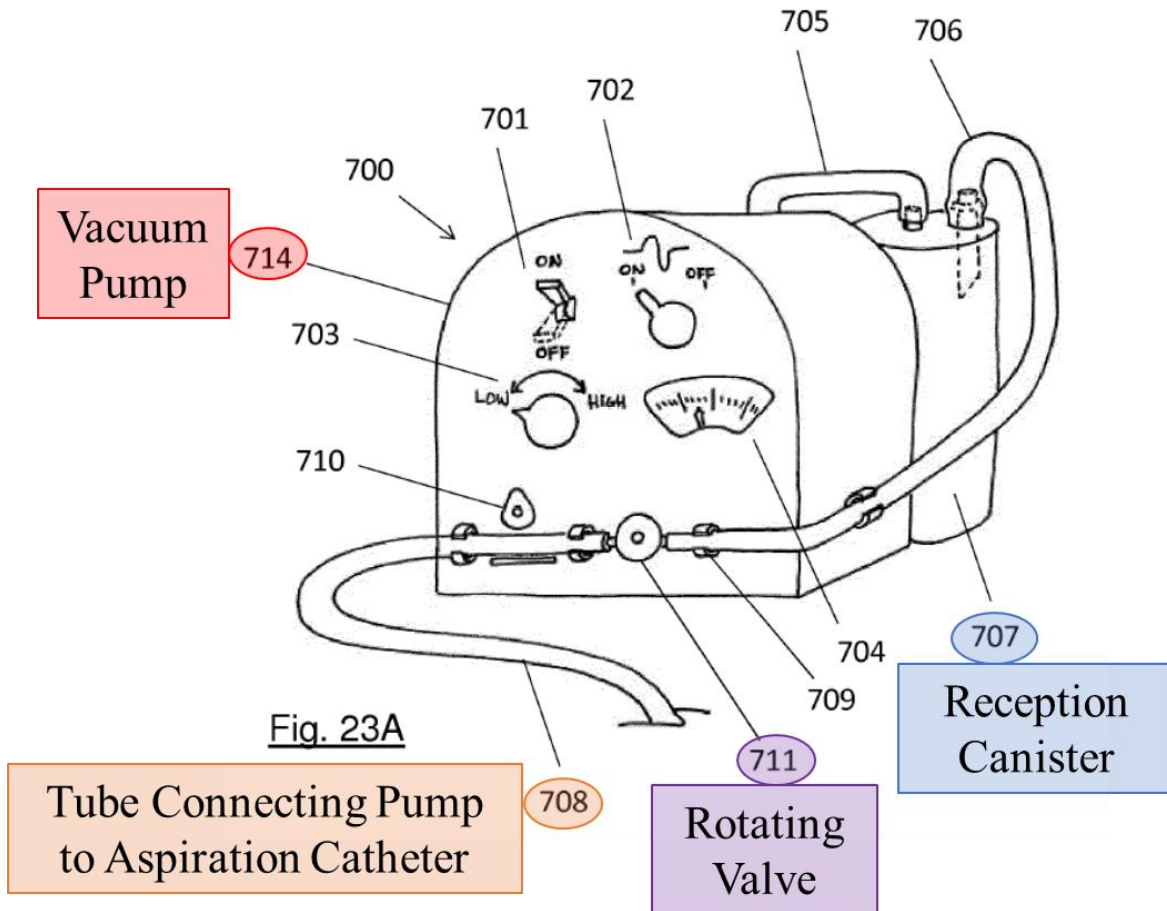

(Ex. 1020, 21:16-22:24, Fig. 23A; Ex. 1003, ¶158.)

2. Laub and Aklog

Laub discloses using pumps with its aspiration system capable of generating from 0-400mmHg of pressure and/or a flow rate of up to 5000mL/min. (Ex. 1012, [0042]-[0043].) Also, Aklog’s system can be used with “any commercially available pump, including those for medical applications and those capable of pumping fluids, such as blood.” (Ex. 1005, 11:62-12:14.) Given these disclosures and the available pumps like Brady above, a POSITA would have found it obvious to use an aspiration

source with Laub’s or Aklog’s systems that had a volume greater than the volume of the clot canister. (Ex. 1003, ¶159.)

For example, the Penumbra Pump Max, an aspiration pump that was commercially available prior to August 2018, used a 1000mL canister. (Ex. 1038.) The Madela Dominant Flex Suction Pump used a 1500mL canister and could provide suction up to -95kPa (-712.558mmHg). (Ex. 1039.) The AXS Universal Aspiration set used with the Madela pump included a clot canister with a smaller volume than the pump canister:

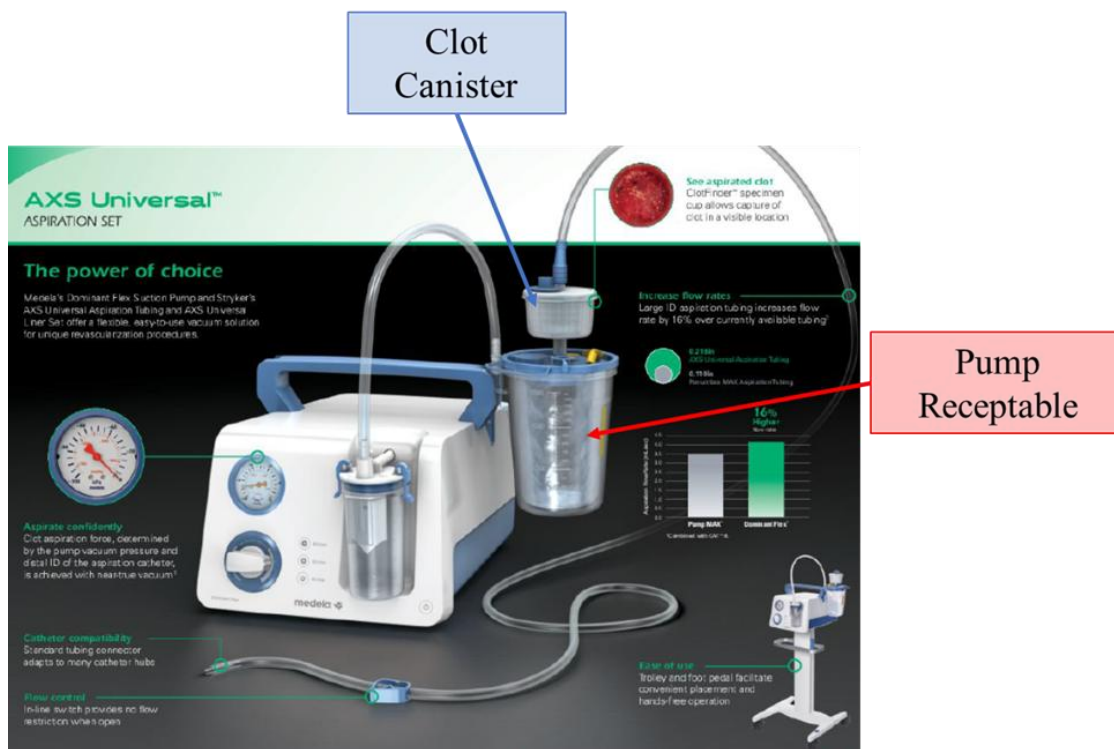

(See *id.*) Also, VacLok Negative Pressure syringes were commercially available before August 2018 at volumes up to 60mL. (Ex. 1040; Ex. 1041, 906.)

A POSITA would have found it obvious to use a clot canister with a volume that was smaller than the above volumes of commercially available aspiration sources. (Ex. 1003, ¶161.) A POSITA would have had a binary choice – either the clot canister has a volume larger than the pump volume or visa versa, and it would have been obvious for a POSITA to try either configuration and optimize the configuration for the anticipated amount of clot material and blood being withdrawn. (*Id.*, ¶159.) Further, the clot canister would only require a volume large enough to filter and collect the aspirated clot material, which would typically be less than the 60mL-1500mL volumes commonly used in commercially available aspiration sources. (*Id.*, ¶161.)

K. Claim 18

Claim 18 recites the “method of claim 1 wherein advancing the aspiration catheter comprises inserting through the vasculature an aspiration catheter having a size of 16 French or greater and an inner diameter, and wherein the fluid path from the aspiration catheter through the valve to the clot canister has a diameter that is the same as or greater than the inner diameter.” Laub or Aklog combined with Garrison, and Garrison combined with Laub or Aklog renders Claim 18 obvious. (Ex. 1003, ¶¶162-167.)

1. Laub

Laub discloses that “[i]n some embodiments, aspiration catheter 200 has a French size of at least 16 Fr.” (Ex. 1012, [0028].) Laub further discloses that its system “includes a fluid path 250 that places aspiration catheter 200 in fluid communication with inlet port 410 of pump 400.” (*Id.*, [0039].) The fluid path may be an elongate tube that is integral with or separable from the aspiration catheter. (*Id.*) Laub does not expressly disclose the fluid-path diameter. However, a POSITA would have been motivated to use a tube for the fluid path with a diameter that is at least the same size or larger than the aspiration catheter to maximize the flow rate of aspirated blood through the fluid path and avoid choke points in the system. (Ex. 1003, ¶164.) In fact, Garrison describes such an arrangement. (Ex. 1006, [0059].) If the tubing had a smaller inner diameter than the catheter, then clot aspirated through the catheter could clog the tubing, which would render the system ineffective. (Ex. 1003, ¶164.)

2. Aklog

A POSITA would have found it obvious to use an aspiration catheter having a diameter of at least 16Fr with Aklog’s system for the reasons explained for Claim 2. (*Supra* §VI.B.2.) Aklog discloses that its filter is in fluid communication with the aspiration catheter (Ex. 1005, 11;24-26), and a POSITA would have been motivated to use tubing to connect the aspiration catheter with the filter having at

least the same or greater diameter as the aspiration catheter for the reasons in the preceding section. (*Supra* §VI.K.1.)

3. Garrison and Laub or Aklog

Laub and Aklog disclose or render obvious aspirating PE with catheters having a size 16 Fr. or greater. (*Supra* §§VI.B.1-2.) POSITAs would have been motivated to use the catheters of Laub or Aklog with Garrison’s system to treat PE as explained in Claim 1. (*Supra* §§VI.A.1.) Garrison’s filter is in fluid communication with the aspiration catheter. (Ex. 1006, [0131]-[0134], Figs. 33-34). Garrison also discloses that “the connection to the flow line is optimized for aspiration of thrombus with flow lumens *at least as large* as the ID of the arterial access device 2010.” (*Id.*, [0059] (emphasis added).) In addition, a POSITA would have been motivated to use tubing having at least the same or greater diameter as the aspiration catheter for the reasons provided above. (*Supra* §VI.K.1.)

L. Claim 19

Claim 19 recites the “method of claim 1 wherein the aspiration source has a volume of 60 cubic centimeters or greater.” Laub or Aklog combined with Garrison, and Garrison combined with Laub or Aklog renders Claim 19 obvious. (Ex. 1003, ¶¶168-170.)

Laub discloses pumps capable of generating from 0-400mmHg of pressure and/or a flow rate of up to 5000mL/min, which would have required a receptacle

larger than 60cc. (Ex. 1012, [0042]-[0043]; Ex. 1003, ¶70.) Aklog’s system can be used with “any commercially available pump, including those for medical applications and those capable of pumping fluids, such as blood.” (Ex. 1005, 11:62-12:14.) Garrison discloses using “a syringe or other manual aspiration device, or an aspiration pump.” (Ex. 1006, [0072]; *see also id.*, [0134].)

Given these disclosures, a POSITA would have found it obvious to use an aspiration source with Laub’s, Aklog’s, or Garrison’s systems that had a volume of 60cc or greater. (Ex. 1003, ¶170.) As explained for Claim 16, commercially available aspiration pumps and syringes disclosed in the prior art had volumes ranging from 60 – 1500mL (60 – 1500cc). (*Supra* §VI.J.)

M. Claims 20-24, 28-29, 33-35, 37-38

Claims 20-24, 28-29, 33-35, and 37-38 of the ’333 patent recite a method of treating DVT instead of PE, but otherwise include the same limitations as Claims 1-5, 9-10, 14-16, and 18-19. Both Laub and Aklog disclose aspiration systems for treating DVT. (Ex. 1003, ¶¶173-174.) Garrison combined with Laub or Aklog also renders the method of treating DVT obvious. (*Id.*, ¶175.)

1. Laub

Laub discloses that its system is suitable for “removing thrombi and other unwanted material from the body of a patient, particularly from the patient’s vasculature.” (Ex. 1012, [0005].) Laub further discloses that its “aspiration catheter

200 may be positioned to aspirate blood from a patient's vein (e.g., right common femoral vein) during use.” (*Id.*, [0025].) POSITAs would have recognized that aspirating clot material from a patient’s right common femoral vein is a method of treating DVT. (Ex. 1003, ¶173.) Accordingly, POSITAs would have been motivated to use Laub’s system to treat DVT and would have reasonably expected success doing so. (*Id.*)

2. Aklog

Aklog discloses removing clot material from different parts of the vasculature, including “systemic venous circulation (e.g., vena cavae, pelvic veins, leg veins, neck and arm veins).” (Ex. 1005, 7:32-37; *see also id.*, 1:17-24, 5:11-19, 5:28-41, Figs. 1, 6-7.) Aklog further discloses removing material from, *inter alia*, the “deep veins of the pelvic, legs, arms or neck.” (*Id.*, 15:38-45.) Accordingly, Aklog discloses methods of treating DVT. (Ex. 1003, ¶174.)

3. Garrison and Laub or Aklog

For the reasons provided in Claim 1, a POSITA would have found it obvious to use or optimize Garrison’s aspiration system to treat DVT based on Laub or Aklog and the knowledge of a POSITA. (Ex. 1003, ¶175; *supra* §VI.A.1.)

The references disclose the remaining limitations of Claims 20-24, 28-29, 33-35, and 37-38 for the reasons explained for Claims 1-5, 9-10, 14-16, and 18-19. (*Supra* §§VI.A-L.)

Laub’s separator “may be a screen, mesh, membrane, etc.” (*Id.*) Once aspirated blood passes through the filter, “the solid materials collected within housing 310 of filter 300 can then be subsequently disposed of or retrieved for additional analysis.” (*Id.*, [0040].) Laub does not expressly disclose how the solid material is retrieved from the filter housing. However, a POSITA would have understood that the filter housing must be openable to retrieve the solid material. (Ex. 1003, ¶177.)

Aklog’s aspiration system also includes a filter device 14 (clot canister) having a permeable sheet 143 positioned between the inlet and outlet ports. (Ex. 1005, 11:24-35.)

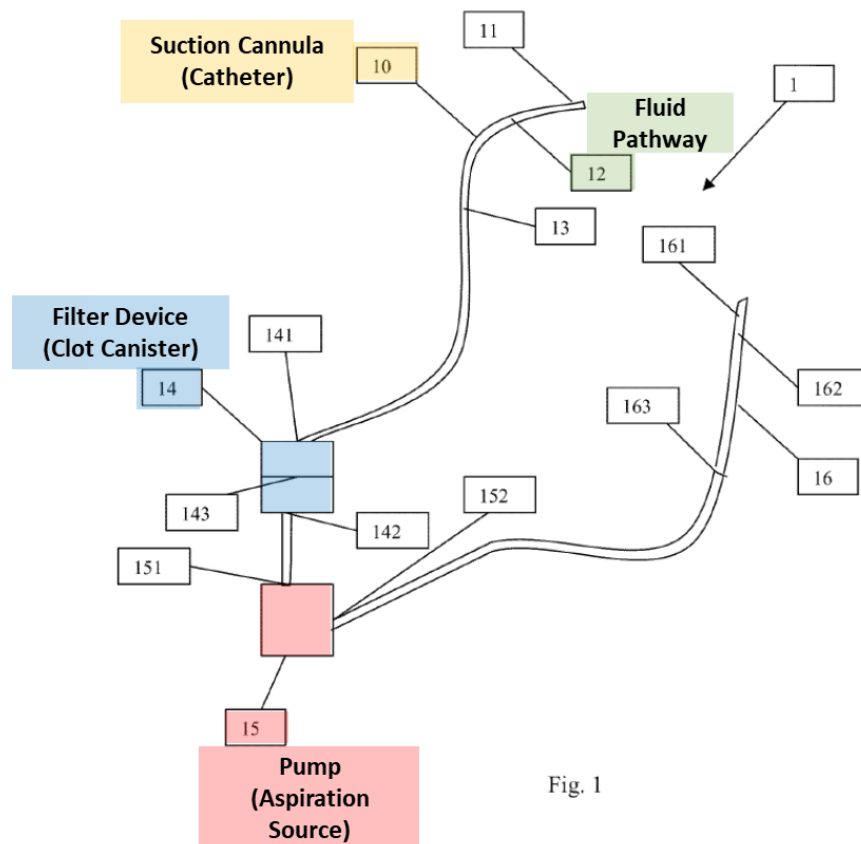

Fig. 1

The permeable sheet may be “coarse netting, fine netting, a screen, a porous filter, a combination thereof, or any other suitable filter material capable of permitting fluid to flow through while impeding movement of the captured undesirable material.” (*Id.*, 11:40-45.) Aklog further discloses that “filter device 14 may be provided with any design capable of entrapping the undesirable material, while allowing fluid to move therethrough.” (*Id.*, 11:54-57.)

Garrison also discloses a filter 3418 within a clot canister for removing unwanted material from the blood. (Ex. 1006, [0131], Fig. 34.)

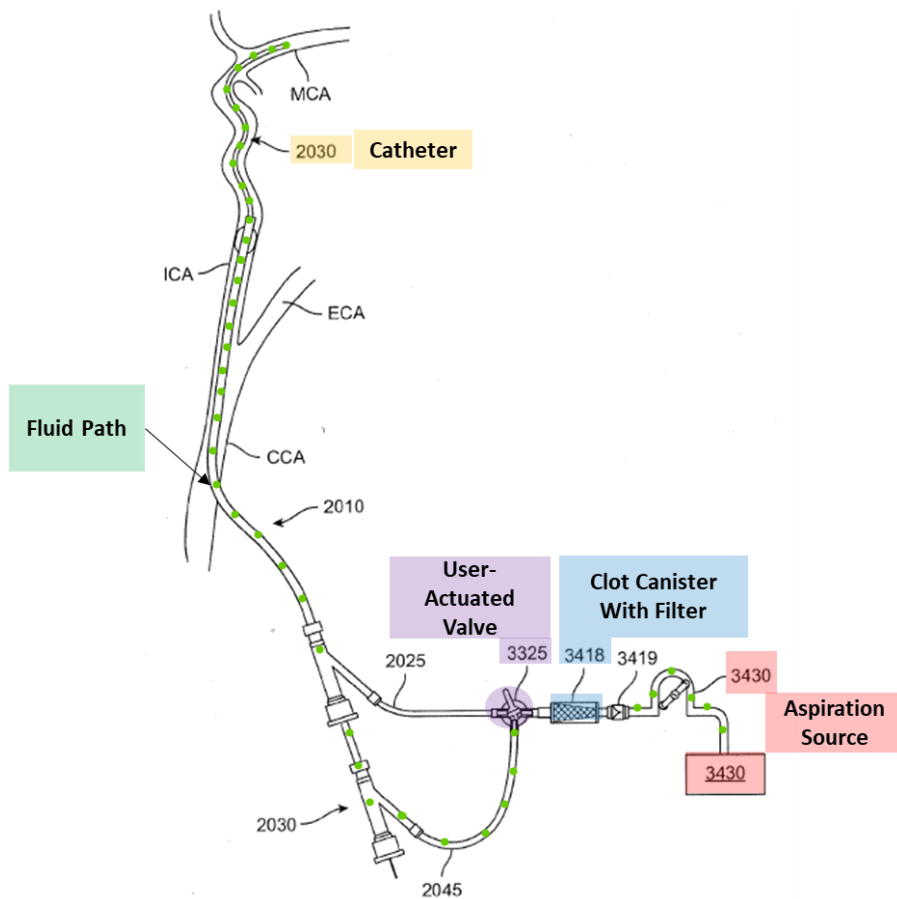
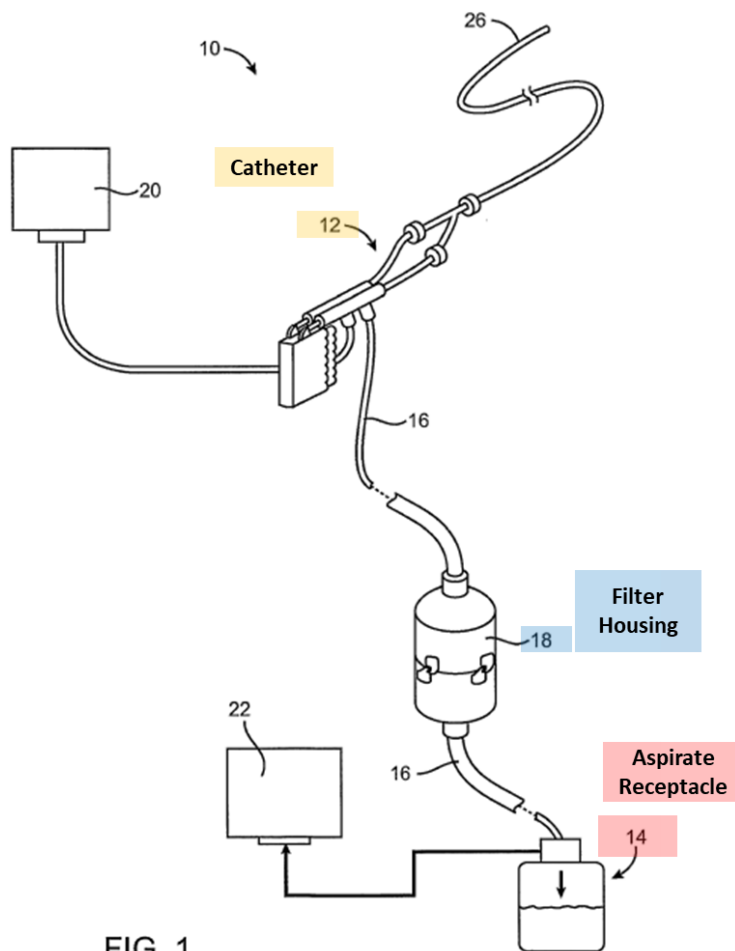

FIG. 34

Laub, Aklog, and Garrison do not expressly disclose that the filter is removable from the filter housing/canister. However, in August 2018, a POSITA would have found it obvious to include a removable filter based on Goff. (Ex. 1003, ¶¶180-186.)

Goff discloses “methods and systems for filtering aspirated material.” (Ex. 1007, Title.) Goff’s aspiration system includes a “filter housing 18 ... between the aspiration catheter 12 and the aspirate receptacle 14”:



(*Id.*, [0025], Fig. 1.)

Goff’s “filter assembly 18 typically comprises an upper shell 30, a lower shell 32, and a filter element 34 which may be disposed within the interior of the shells”:

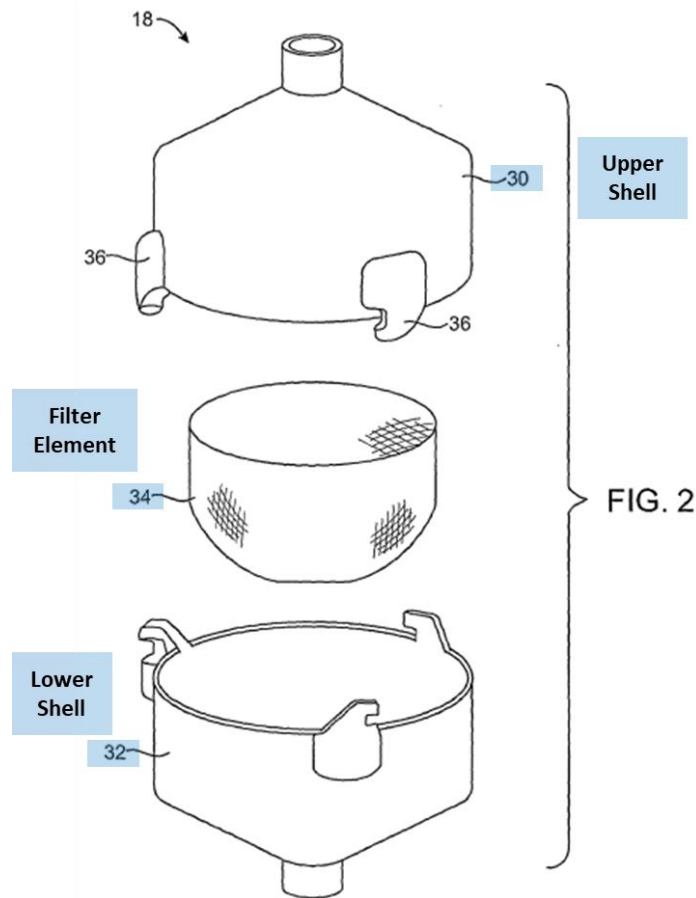

(*Id.*, [0025], Fig. 2). Goff explains that the upper shell and lower shell “may be taken apart to permit introduction, removal, and replacement of the filter element in the interior of the housing.” (*Id.*, [0015].) Goff discloses that its filter forms a structure where “the separated solid materials be in a convenient structure or assembly to permit easy removal and observation.” (*Id.*, [0005].)

Goff would have motivated a POSITA to include a removable filter in Laub, Aklog, or Garrison so that the physician could retrieve samples, empty the housing, and clean or replace the filter. (Ex. 1003, ¶183.) If the filter of Laub, Aklog, or Garrison were not already openable, Goff would have motivated a POSITA to configure the filter housing/canister so that it could be opened to permit this removal or cleaning. (*Id.*) Filter housings/canisters that could be unscrewed (left) or unclamped (right) were well known:

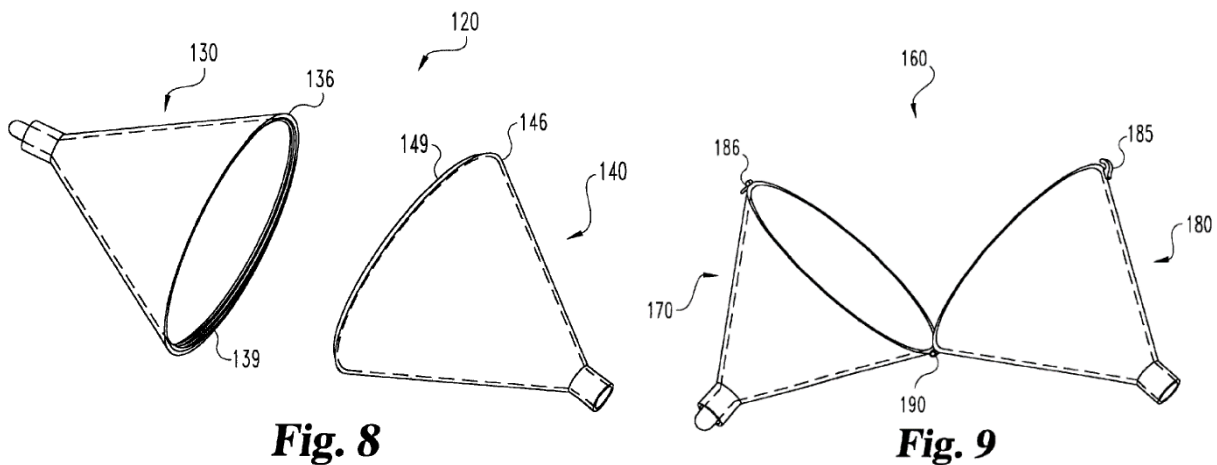
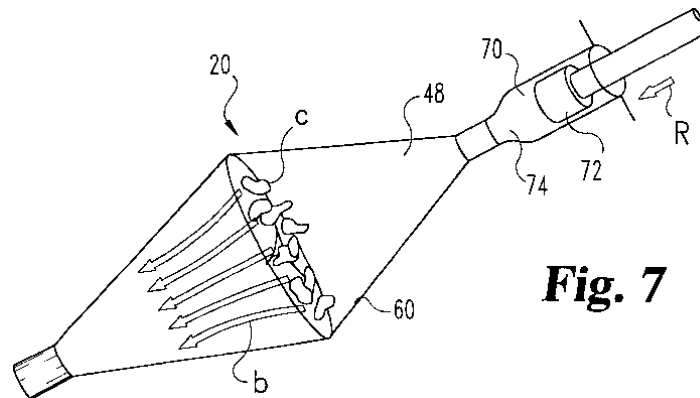

(Ex. 1009, 5:65-6:10, Figs. 7-9.) A POSITA would have reasonably expected success in designing Laub, Aklog, or Garrison to have a removable filter because

the parts needed to create such a filter (e.g., hinge, clip, interlocking tabs, or screw threads) were simple and predictable and would have been well understood by POSITAs. (Ex. 1003, ¶183.)

Alternatively, a POSITA would have been motivated to simply substitute Goff's filter assembly for the filters in Laub, Aklog, and Garrison. (Ex. 1003, ¶184.) Goff's filter assembly is used for the same purpose as Laub's, Aklog's, and Garrison's filters – filtering clots from aspirated blood. (Ex. 1007, [0001].) Goff's filter assembly is also positioned between the aspiration catheter and aspiration source with standard medical tubing. (*Id.*, [0025].) Thus, substituting Goff's filter assembly for Laub's, Aklog's, or Garrison's filter would have merely entailed the substitution of one known elements (Goff's filter assembly) for another (Laub's/Aklog's/Garrison's filter) to yield the predictable result of filtering aspirated blood. *KSR*, 550 U.S. at 416; (Ex. 1003, ¶184.)

Moreover, a POSITA would have reasonably expected success in making the substitution due to the similarities between the systems. (Ex. 1003, ¶185.) All four systems filter clots from blood aspirated from a patient. Goff specifically discloses that its “filter element will have a pore size or screen size selected to separate solid particles at a desired particle size cutoff,” the same requirement for the filters in Laub, Aklog, and Garrison. (Ex. 1007, [0011].) For these reasons, Laub or Aklog or Garrison in combination with Goff renders this claim obvious.

B. Claim 7

Claim 7 recites the “method of claim 1 wherein the method further comprises removing the portion of the pulmonary embolism from within the clot canister.” Laub or Aklog combined with Garrison and optionally Goff, and Garrison combined with Laub or Aklog and optionally Goff renders Claim 7 obvious. (Ex. 1003, ¶¶187-189.)

As explained above, Goff’s removable filter allows for the clot material to be “easily observed and optionally removed from the aspiration circuit even while the aspiration protocol continues.” (Ex. 1007, [0007]; *supra* §VII.A.) Goff explains that the collected clot material “could be used to diagnose certain disease states or conditions.” (Ex. 1007, [0033].) Likewise, Laub discloses that clot material may be retrieved from its filter for additional analysis. (Ex. 1012, [0040].)

Based on Goff’s teachings, a POSITA would have been motivated to remove the aspirated clot (e.g., PE or DVT) from Laub’s, Aklog’s, and Garrison’s filters (or Goff’s filter if it were substituted for the existing filters) so it could be analyzed. (Ex. 1003, ¶189.) Additionally, POSITAs would have been further motivated to remove the aspirated clots so the filter could be reused. (*Id.*)

C. Claim 8

Claim 8 depends from Claim 7 and further recites the steps of (1) “after removing the portion of the pulmonary embolism from within the clot canister,

positioning the filter within the clot canister”; (2) “repeating generating vacuum pressure within the clot canister via the aspiration source while the valve is in the first position”; and (3) “repeating moving the valve from the first position to the second position thereby applying the vacuum pressure to the lumen of the aspiration catheter to aspirate at least another portion of the pulmonary embolism and additional blood into the clot canister.” Laub or Aklog combined with Garrison and optionally Goff, and Garrison combined with Laub or Aklog and optionally Goff renders Claim 8 obvious. (Ex. 1003, ¶¶190-196.)

1. Laub

Laub and Garrison render the limitations regarding the valve with a first position and second position obvious as explained in Claim 1. (*Supra* §VI.A.3.) Laub alone and combined with Goff renders the limitations of Claim 7 obvious. (*Supra* §VII.B.) Garrison specifically discloses using its system for repeated aspiration of multiple clot portions. (Ex. 1006, [0166].) Additionally, after removing a first portion of PE from the clot canister, a POSITA would have found it obvious to repeat the aspiration steps taught by Laub and Garrison to remove a second portion of the PE. (Ex. 1003, ¶192.) A POSITA would have known that incomplete removal of the PE could lead to health risks, and a POSITA would have therefore been motivated to repeat the aspiration steps until the entire embolism was removed. (*Id.*)

2. Aklog

Aklog and Garrison render the limitations regarding the valve with a first position and second position obvious as explained in Claim 1. (*Supra* §VI.A.3.) Aklog alone and combined with Goff renders the limitations of Claim 7 obvious. (*Supra* §VII.B.) A POSITA would have been motivated to repeat the aspiration steps taught by Aklog and Garrison to remove a second portion of the PE for the reasons explained for Laub. (*Supra* §VII.C.1.) Moreover, Aklog discloses that its aspiration system may “be employed to remove a plurality of undesirable materials,” including separate clots within the same or different vessels. (Ex. 1005, 18:7-13.) Aklog discloses that after the first clot material is removed, “the suction force may be deactivated” while the suction cannula is positioned near the second clot. (*Id.*, 18:13-20.) Once in position, the suction force is reapplied until the second clot is removed. (*Id.*) Aklog’s disclosure that its system can be used for repeated aspiration procedures would have reinforced a POSITA’s reasonable expectation of success in using Aklog’s system for repeated aspiration of two portions of a PE. (Ex. 1003, ¶194.)

3. Garrison

Garrison combined with Laub or Aklog renders the limitations regarding the valve with a first position and second position obvious as explained in Claim 1. (*Supra* §VI.A.3.) Garrison alone and combined with Goff renders the limitations of

Claim 7 obvious. (*Supra* §VII.B.) A POSITA would have been motivated to repeat the aspiration steps taught by Garrison to remove a second portion of the PE for the reasons explained above. (*Supra* §VII.C.1.) Moreover, Garrison discloses a process for the physician to remove multiple occlusions with Garrison’s aspiration system. (*See e.g.*, Ex. 1006, [0166] (“if a second more distal treatment site needs to be reached after removal of a first occlusion, a second, smaller diameter catheter may be inserted through the first catheter”).) Garrison’s disclosure that its system can be used for repeated aspiration procedures would have reinforced a POSITA’s reasonable expectation of success in using Garrison’s system for repeated aspiration of two portions of a PE. (Ex. 1003, ¶196.)

D. Claim 17

Laub or Aklog combined with Garrison Goff and Garrison combined with Laub or Aklog and Goff renders this claim obvious. (Ex. 1003, ¶¶197-199.) As discussed above, Garrison discloses a filter having a generally tubular shape. (*Supra* §VI.A.2.) Goff also discloses a filter housing having a generally tubular shape:

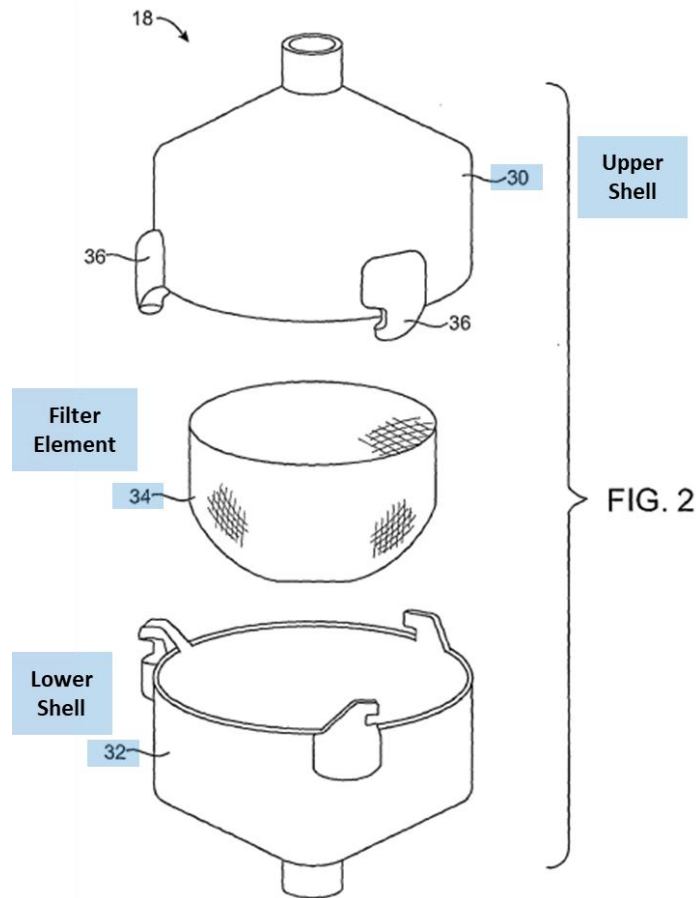

(Ex. 1007, [0015], [0025], Fig. 2.) POSITAs would have been motivated to substitute Goff’s filter for the filter in Laub, Aklog’s, and Garrison’s systems, and reasonably expected success in doing so, for the reasons explained for Claim 6. (*Supra* §VII.A.)

E. Claims 25-27 and 36

Claims 25-27 and 36 repeat the limitations in Claims 6-8 and 17 with the exception that Claim 26 specifies that a portion of a DVT, as opposed to a PE, is removed from the filter. As explained in Claim 7, Goff discloses removing the clot material captured by the filter, regardless of the type of clot, and a POSITA would

have found it obvious to remove the captured portion of a PE or DVT. (*Supra* §VII.A.) Therefore, Laub or Aklog with Garrison and optionally Goff, and Garrison with Laub or Aklog and optionally Goff render these claims obvious for the reasons previously provided. (*Supra* §§VII.A-C.)

VIII. GROUNDS 1C-1D, 2C-2D, 3C-3D, 4C-4D – LAUB, AKLOG, AND GARRISON WITH SCHAFFER AND OPTIONALLY HARTLEY

A. Claim 11

Claim 11 recites the “method of claim 10 wherein selectively providing fluid access to the lumen of the aspiration catheter includes decreasing a tension on a filament of the hemostasis valve thereby providing fluid access to the lumen of the aspiration catheter and increasing the tension on the filament to inhibit fluid access to the lumen of the aspiration catheter.” Laub or Aklog with Garrison and Schaffer and optionally Hartley renders Claim 11 obvious. (Ex. 1003, ¶¶202-230.) Garrison with Laub or Aklog and Schaffer and optionally Hartley also renders Claim 11 obvious. (*Id.*)

As explained for Claim 10, Laub, Aklog, and Garrison, or combinations thereof, describe aspiration systems with a hemostasis valve. (*Supra* §VI.G.) However, Laub, Aklog, and Garrison do not describe the details of their hemostasis valves, presuming instead that POSITAs would have been familiar with the available valves. However, Schaffer and Hartley describe hemostasis valves that control the flow of fluid through a lumen by adjusting tension on a filament. A POSITA in

August 2018 would have found it obvious to use the hemostasis valves disclosed by Schaffer and Hartley in the aspiration systems of Laub, Aklog, or Garrison. (Ex. 1003, ¶204.)

1. Schaffer

Schaffer discloses an adjustable opening “fluid stasis valve” for use with catheters to prevent the flow of blood through the valve. (Ex. 1013, [0002], [0046], [0055].) Schaffer’s valve has “two circular actuators 50” on opposite sides of the housing that are “movable from a first position to a second position”:

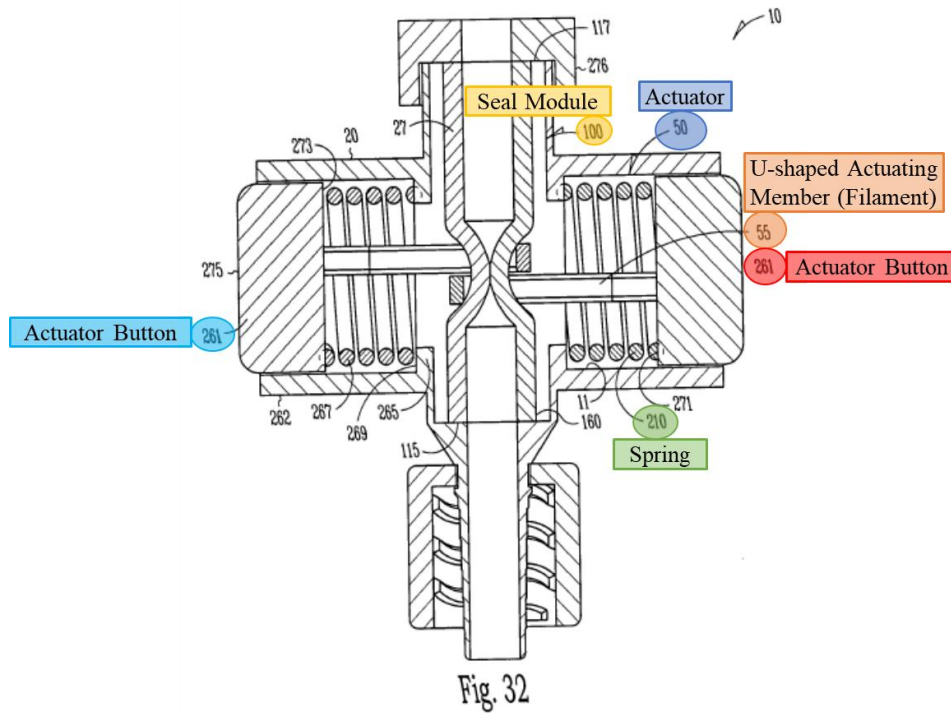

(*Id.*, [0075]-[0076], Figs. 31-32.)³ Each actuator 50 includes “an actuator button 261” attached to a “spring 210.” (*Id.*) Schaffer’s actuator buttons are each coupled to “an actuating member 55 which, in one option, is U-shaped.” (*Id.*, [0076].)

Schaffer’s actuating members are a “filament.” (*Supra* §IV; Ex. 1003, ¶206.) Schaffer’s actuating members are formed from metal or plastic, and resemble a ribbon, flat wire, or tape. (Ex. 1013, [0081], Figs. 31-34; Ex. 1003, ¶206.) Schaffer’s description of the actuating members is consistent with the ’519 application, which states that the filament can be made from a polymer (e.g., Schaffer’s plastic) or a metal (e.g., Schaffer’s aluminum). (*Supra* §IV.) Likewise, the ’519 application states that a filament may be a ribbon, flat wire, or tape, which includes Schaffer’s U-shaped actuating members. (*Id.*) In related proceedings, PO argued that Schaffer’s actuating members are “rigid.” *Imperative Care*, IPR2024-01157, Paper 5 at 28. However, Mr. Thornton explains why these arguments are inconsistent with Schaffer. (Ex. 1003, ¶¶207-211.)

Schaffer’s actuators and springs pull on, or apply tension to, the actuating members to close the valve to fluid flow and release, or decrease tension on, the actuating members to open the valve. (Ex. 1003, ¶212.) Schaffer discloses that in a

³ Petitioner uses the versions of Schaffer’s drawings submitted during prosecution on June 18, 2003 (Ex. 1050) because they are clearer. The drawings became publicly available when Schaffer published on December 4, 2003. 37 C.F.R. §1.11.

first position (below), the actuating members are “at least partially circumferentially disposed about the portion 108 of the seal module 100 depressing and at least partially collapsing a portion 108 of the containment structure 160 by a compressive force 67 (e.g. by a spring 210)”:

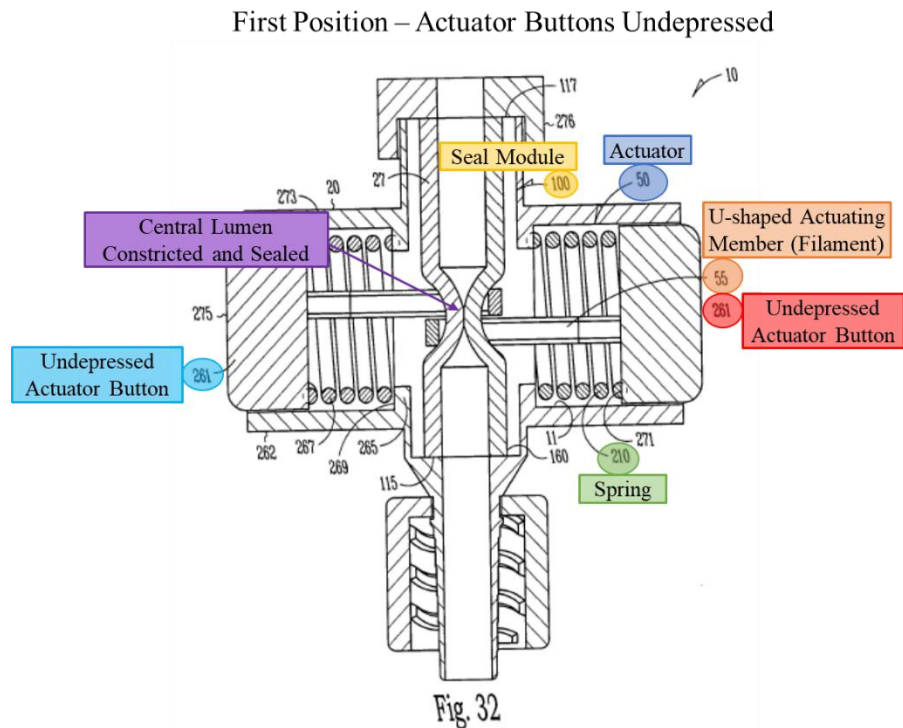

(Ex. 1013, [0077], Fig. 32.) In a second position (below), the actuator buttons are pressed inwardly, compressing the springs to relieve tension on the actuating members, allowing the seal module 100 to return to its uncollapsed configuration so fluid can pass:

Second Position – Actuator Buttons Depressed

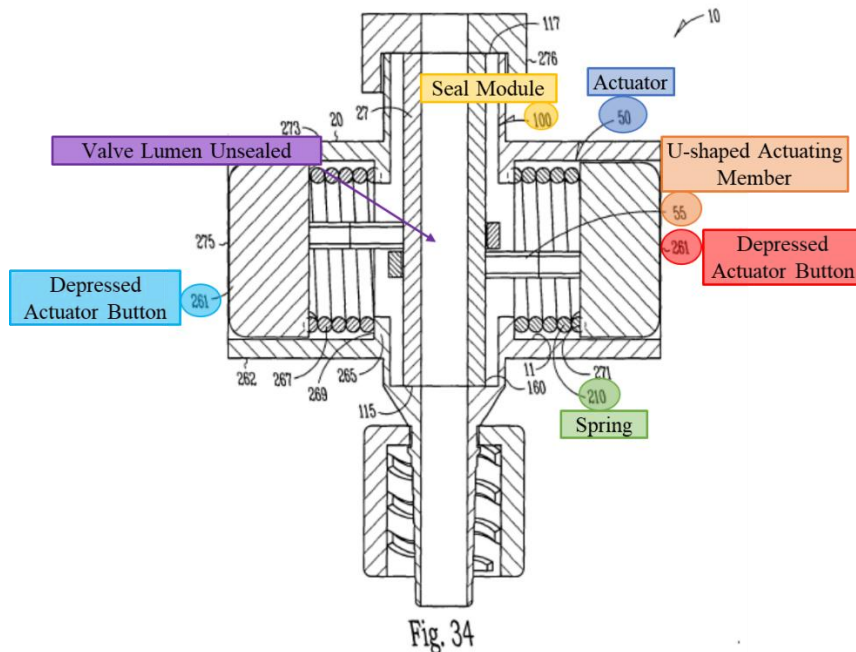

(*Id.*, [0077], Fig. 34.)

A POSITA would have been motivated, and found it obvious, to use Schaffer’s valve (with or without Hartley’s string – *see* below) with Laub’s, Aklog’s, or Garrison’s aspiration systems. (Ex. 1003, ¶¶213-217.) First, Schaffer discloses that its hemostasis valve is “for use with catheters” and “blocks the flow of gas or fluid completely and immediately with or without an instrument in place within the gas/fluid path.” (Ex. 1013, [0002], [0008], [0047], [0049].) Schaffer further discloses that a range of instruments can be used within the valve, such as “a catheter, guidewire, needle, or fiber.” (*Id.*, [0056], [0074].) Thus, Schaffer’s valve would permit tools to be inserted through Laub’s working port 230, Aklog’s port 51, or

Garrison's proximal hub/adaptor 2065, while preventing blood from leaking through the ports. (Ex. 1003, ¶214.)

Second, POSITAs would have recognized that Schaffer's hemostasis valve could simplify the aspiration systems. (Ex. 1003, ¶215.) For example, Schaffer's springs bias the valve toward the closed position, eliminating the need to manually seal the valve during procedures as occurred with some prior-art valves. (*Id.*)

Third, the combination of Schaffer's valve with the aspiration systems would have merely entailed the combination of known elements (Schaffer's valve and Laub's/Aklog's/Garrison's systems) according to known methods (attaching or forming integrally the valve with a port/hub) to yield the predictable result of minimizing blood loss through the catheter. *See KSR*, 550 U.S. at 416; (Ex. 1003, ¶216.)

Fourth, POSITAs in August 2018 had a finite number of predictable hemostasis valves to select. (Ex. 1003, ¶217.) A POSITA would have found it obvious to try any of these hemostasis valves with the prior art aspiration systems. (*Id.*); *KSR*, 550 U.S. at 417. The known valves, like Schaffer's adjustable-opening hemostasis valve, were simple mechanical structures that operate in a predictable way. (Ex. 1003, ¶217.) For this additional reason, POSITAs would have reasonably expected success in combining Schaffer's valve with Laub's, Aklog's, or Garrison's systems. (*Id.*)

2. Schafer and Hartley

Hartley describes a hemostasis valve having a cylindrical housing that holds a “cylindrical elastomeric diaphragm,” and a rotary actuator mounted to the housing:

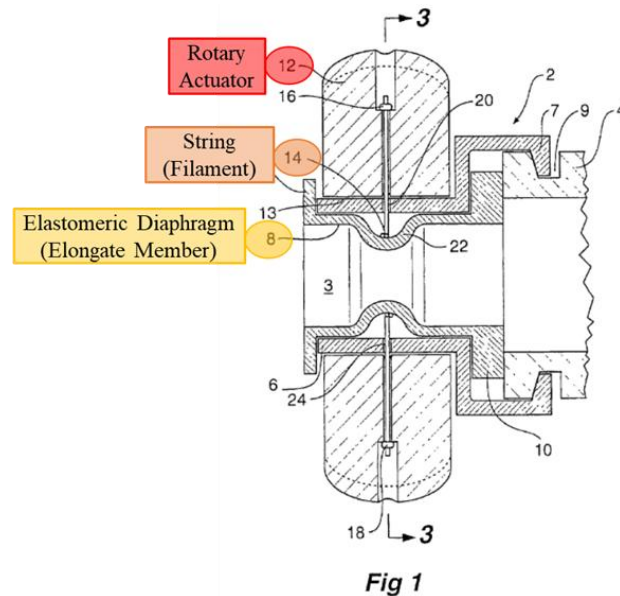

(Ex. 1008, [0031], Fig. 1.) Hartley’s valve includes a “string 14 ... mounted into the rotary actuator.” (*Id.*) Hartley’s string 14 is a “filament” because the string is made of one or more threads, lines, or cords. (Ex. 1003, ¶218.)

Hartley discloses that “[r]otation of the rotary actuator 12 with respect to the cylindrical housing 6 will cause the string 14 to be pulled in both directions at once and hence the cylindrical diaphragm 8 to be constricted.” (Ex. 1008, [0031], [0034], Fig. 4.) Hartley further discloses the valve “will close over a range of diameters of devices passed through the valve or can close completely down to be self sealing.” (*Id.*, [0037].) Thus, Hartley’s valve closes the lumen to fluid flow by increasing

tension on the filament and opens the lumen to fluid flow by relaxing the tension.
(Ex. 1003, ¶219.)

If Schaffer’s u-shaped actuating members are not a “filament,” POSITAs would have found it obvious to substitute Hartley’s string for Schaffer’s actuating members. (Ex. 1003, ¶¶220-225.) The combination of Hartley’s string and Schaffer’s valve would have merely entailed substitution of one known element (Hartley’s string) for another (Schaffer’s actuating members) to yield the predictable result of sealing Schaffer’s valve. *KSR*, 550 U.S. at 416.

Hartley’s disclosure that its string can “close over a range of diameters of devices passed through the valve or can close completely down to be self-sealing” would have further motivated POSITAs to substitute Hartley’s string for Shaffer’s actuating members. (Ex. 1008, [0037]; Ex. 1003, ¶220.) POSITAs would have recognized that Hartley’s string may seal more effectively across a wider range of tool diameters and shapes than Schaffer’s U-shaped actuating members. (Ex. 1003, ¶221.) Depending on the inserted tool, Schaffer’s actuating members may form small gaps between the valve’s seal module and the tool’s outer surface:

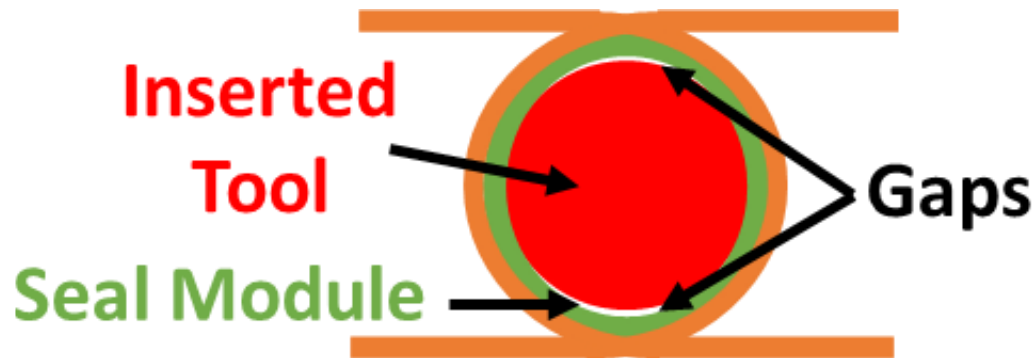

(*Id.*) Hartley’s string would not suffer from this potential issue because the string more precisely conforms to the tool diameters. (*Id.*) In related proceedings, PO argued that Schaffer’s valve would not create gaps. *Imperative Care*, IPR2024-01157, Paper 5 at 28-29. However, the portions of Schaffer cited by PO do not support its argument. (Ex. 1003, ¶222.)

POSITAs also had a finite number of materials to select from to constrict a tubular member in a hemostasis valve in 2018. (*Id.*, ¶225.) Hartley and Schaffer disclose two such materials: Hartley’s string and Schaffer’s actuating members. (*Id.*) A POSITA would have found it obvious to select from these finite, predictable options and, as discussed below, would have had a reasonable expectation of success in implementing them. (*Id.*); *KSR*, 550 U.S. at 421.

POSITAs would have had a reasonable expectation of success in substituting Hartley’s string for Schaffer’s actuating members. (Ex. 1003, ¶¶226-228.) Hartley teaches using simple knots to attach the string to the rotary actuator. (Ex. 1008, [0031].) POSITAs would have reasonably expected that similar knots would secure

Hartley's string to Schaffer's actuator buttons. (Ex. 1003, ¶226.) For example, each end of Hartley's string could be threaded through small holes in Schaffer's buttons and knotted on the other side. (*Id.*) This simple modification would have been within a POSITA's skills:

Demonstrative Illustration Schaffer + Hartley's String

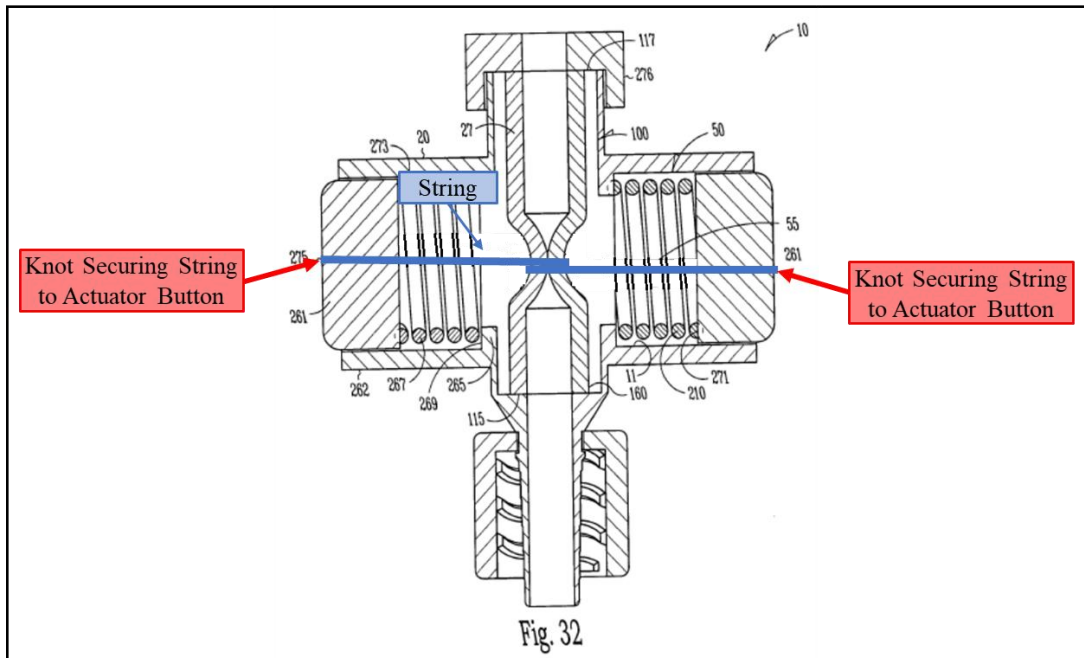

(*Id.*)⁴

Also, POSITAs would have recognized that Hartley's string and Schaffer's actuating members function in similar ways and, therefore, no other modifications to Schaffer's valve would be necessary. (*Id.*, ¶227.) Both valves collapse the lumen

⁴ This image is a demonstrative prepared by Petitioner.

by pulling the ends of the actuating members/string in opposite directions. (Ex. 1013, [0077]; Ex. 1008, [0031].) Thus, if Hartley’s string were incorporated into Schaffer’s valve, a POSITA would have reasonably expected Schaffer’s springs to pull the ends of the string in opposite directions to constrict Schaffer’s seal module. (*Id.*; Ex. 1003, ¶227.)

Likewise, POSITAs would have also reasonably expected that pressing Schaffer’s buttons inwardly would release the tension on the string, allowing the lumen to open. (*See* Ex. 1013, [0077]; Ex. 1008, [0034]; Ex. 1003, ¶229.) Schaffer’s seal module is formed from a “highly deformable, non-compressible material 166 (e.g., plastic)” and is “configured to maintain an open lumen 193 when no compressive force 67 is applied.” (Ex. 1013, [0054].) Thus, Schaffer’s seal module has the resilience to open when the tension on the string is released. (Ex. 1003, ¶229.) Moreover, if the resiliency of Schaffer’s lumen required adjustment to function with Hartley’s string, a POSITA would have possessed the skills and knowledge to select a material with the proper resiliency. (*Id.*, ¶230.) Schaffer discloses various materials for the seal module, including “modified vinyl, silicone, polyurethane or a combination thereof.” (Ex. 1013, [0081]; *see also* Ex. 1031, 36:27-60.)

B. Claim 12

Claim 12 recites the “method of claim 11 wherein decreasing the tension on the filament includes depressing a button coupled to the hemostasis valve.” Laub or Aklog with Garrison and Schaffer and optionally Hartley renders Claim 12 obvious. (Ex. 1003, ¶¶231-232.) Also, Garrison with Laub or Aklog and Schaffer and optionally Hartley renders Claim 12 obvious. (*Id.*)

Schaffer’s valve includes two spring-loaded actuator buttons 261 “movable from a first position to a second position on opposing sides of the housing”:

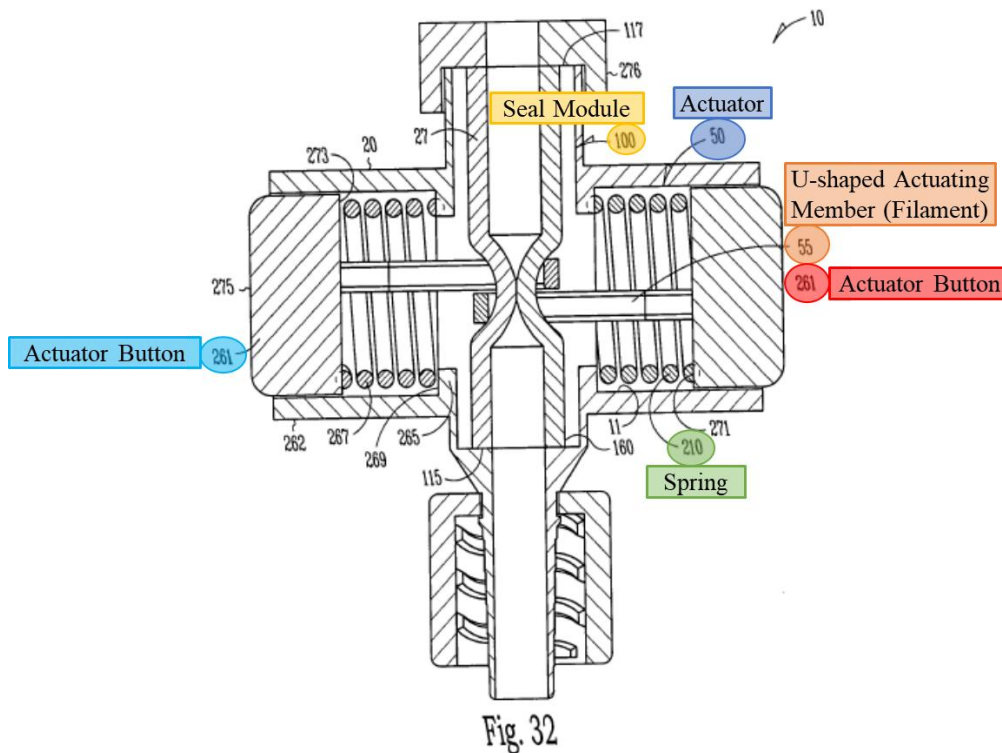

(Ex. 1013, [0075]-[0076], Figs. 31-32.) Schaffer’s actuator buttons are undepressed when the valve is in the first (closed) position and depressed when the valve is in the second (open) position:

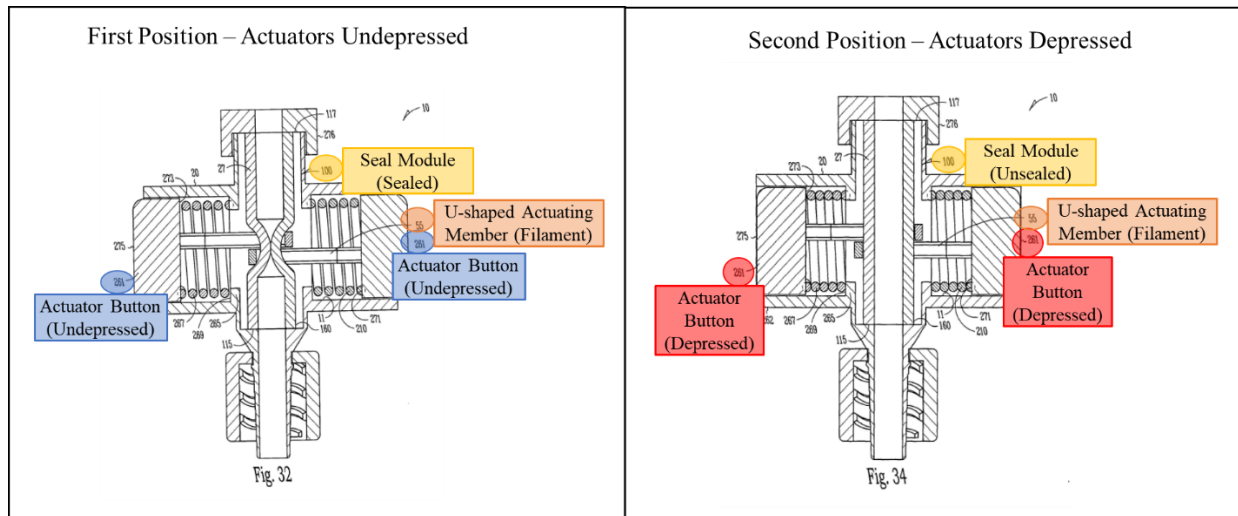

(*Id.*, [0077], Figs. 32, 34; Ex. 1003, ¶232.) A POSITA would have been motivated to combine Schaffer’s valve with the prior art aspiration systems, and reasonably expected success in doing so, for the reasons provided in Claim 11. (*Supra* §VIII.A.)

C. Claims 30-31

Claims 30-31 of the ’333 patent are directed to a method of treating DVT instead of PE, but they otherwise recite the same limitations as Claims 11-12. Therefore, Claims 30-31 are obvious for the same reasons as Claims 11-12. (*Supra* §§VIII.A-B.)

IX. SECONDARY CONSIDERATIONS

Petitioner is not aware of any evidence of secondary considerations. (Ex. 1003, ¶¶234-236.) If PO identifies evidence of secondary considerations, Petitioner respectfully requests an opportunity to respond.

X. SOTERA STIPULATION

Petitioner hereby stipulates that if the Board institutes this IPR based on the grounds and claims raised in the Petition, Petitioner will not pursue in district court the grounds asserted in the IPR Petition or any other ground that could have been reasonably raised in this IPR. Thus, there will be no “overlap in the issues raised in the petition and in the parallel proceeding.” *Apple v. Fintiv*, IPR2020-00019, Paper 11 at 6 (PTAB Mar. 20, 2020) (precedential).

XI. MANDATORY NOTICES, GROUNDS FOR STANDING, AND FEE PAYMENT

A. Real Parties-In-Interest (37 C.F.R. §42.8(b)(1))

Imperative Care, Inc. is the real party in interest for Petitioner.

B. Related Matters (37 C.F.R. §42.8(b)(2))

PO recently filed a Second Amended Complaint alleging that Petitioner’s Symphony system infringes the ’333 patent, as well as U.S. Patent Nos. 11,974,910; 11,554,005; 11,744,691; 11,697,012; 11,844,921, 11,865,291, 12,016,580; 12,109,384; and 12,156,669. *Inari Medical, Inc. v. Imperative Care, Inc.*, No. 24-cv-3117 (N.D. Cal., filed May 22, 2024). In the Second Amended Complaint,

IPR Petition – Patent 11,969,333
Imperative Care, Inc. v. Inari Medical Inc.

Petitioner also dropped its infringement allegations regarding U.S. Patent No. 11,697,011, which is the subject of an instituted IPR. (Ex. 1042.) The court has set a case schedule only through the claim construction hearing, currently set for July 24, 2025. (Ex. 1044.) The court has not set a trial date in the litigation. (*Id.*) PO has also filed a Motion for Leave to File a Third Amended Complaint, which would add U.S. Patent No. 12,239,333 to the litigation. (Ex. 1043.) Petitioner has opposed the Motion and requested that the Court vacate the case schedule until PO is done asserting additional patents. (Ex. 1047.) The motion is scheduled for hearing on May 28, 2025. Petitioner has also filed a Motion to Stay the Litigation pending resolution of the IPRs. (Ex. 1048.) The motion is schedule for hearing on July 16, 2025.

Petitioner has filed six IPRs against patents asserted by PO in the Litigation: (1) *Imperative Care, Inc. v. Inari Medical, Inc.*, IPR2024-01157 requesting review of U.S. Patent No. 11,697,011 (Filed July 8, 2024); (2) *Imperative Care, Inc. v. Inari Medical, Inc.*, IPR2024-01257 requesting review of U.S. Patent No. 11,744,691 (Filed August 12, 2024); (3) *Imperative Care, Inc. v. Inari Medical, Inc.*, IPR2025-00156 requesting review of U.S. Patent No. 11,697,012 (Filed November 8, 2024); (4) *Imperative Care, Inc. v. Inari Medical, Inc.*, IPR2025-00289 requesting review of U.S. Patent No. 11,554,005 (Filed December 13, 2024); (5) *Imperative Care, Inc. v. Inari Medical, Inc.*, IPR2025-00728 requesting review of U.S. Patent No.

IPR Petition – Patent 11,969,333
Imperative Care, Inc. v. Inari Medical Inc.

11,865,291 (Filed March 13, 2025); (6) *Imperative Care, Inc. v. Inari Medical, Inc.*, IPR2025-00989 requesting review of U.S. Patent No. 11,844,921 (Filed May 9, 2025). The Board granted institution of the '011 and '012 patent IPRs and denied institution of the '691 patent IPR for reasons not relevant to this IPR.

C. Lead and Backup Counsel (37 C.F.R. §42.8(b)(3))

Petitioner provides the following designation of counsel, all of whom are included in Customer No. 20,995 identified in Petitioner's Power of Attorney.

Lead Counsel	Back-up Counsel
Joshua J. Stowell (Reg. No. 64,096) 2JYS@knobbe.com BoxImperative333@knobbe.com Knobbe, Martens, Olson, & Bear, LLP <u>Postal and Hand-Delivery Address:</u> 2040 Main St., 14 th Floor Irvine, CA 92614 Telephone: 949-760-0404 Facsimile: 949-760-9502	Joseph R. Re (Reg. No. 31,291) 2jrr@knobbe.com Brian C. Barnes (Reg. No. 75,805) 2BCB@knobbe.com Knobbe, Martens, Olson, & Bear, LLP <u>Postal and Hand-Delivery Address:</u> 2040 Main St., 14 th Floor Irvine, CA 92614 Telephone: 949-760-0404 Facsimile: 949-760-9502

D. Service Information (37 C.F.R. §42.8(b)(4))

Please direct all correspondence to lead counsel and back-up counsel at the addresses shown above. Petitioner also consents to electronic service by email to BoxImperative333@knobbe.com.

E. Grounds for Standing (37 C.F.R. §42.104)

Petitioner certifies that the '333 patent is available for IPR and that Petitioner is not barred or estopped from requesting IPR on the identified grounds. This Petition is being filed within one year of service of the Complaint in the Litigation.

F. Payment of Fees (37 C.F.R. §42.15(a))

The fee for this petition has been paid. Additional fees may be charged to Deposit Account 11-1410.

XII. CONCLUSION

For the reasons above, Petitioner has established a reasonable likelihood of prevailing in showing that at least one or more claims are unpatentable as anticipated or obvious and, therefore, requests that the Board institute an *inter partes* review.

Dated: May 19, 2025

By: /Joshua J. Stowell/
Joshua J. Stowell (Reg. No. 64,096)
Joseph R. Re (Reg. No. 31,291)
Brian C. Barnes (Reg. No. 75,805)

KNOBBE MARTENS OLSON & BEAR, LLP
Attorneys for Petitioner Imperative Care, Inc.

CERTIFICATE OF COMPLIANCE

Pursuant to 37 C.F.R. § 42.24(d), the undersigned certifies that this PETITION FOR *INTER PARTES* REVIEW OF U.S. PATENT NO. 11,969,333 contains 13,834 words according to the word-processing program used to prepare this paper. The foregoing word count complies with the 14,000-word type-volume limit specified by 37 C.F.R. § 42.24(a)(1).

Dated: May 19, 2025

By: /Joshua J. Stowell/
Joshua J. Stowell (Reg. No. 64,096)
KNOBBE MARTENS OLSON & BEAR, LLP

CERTIFICATE OF SERVICE

The undersigned hereby certifies that on the date below a copy of this **PETITION FOR *INTER PARTES* REVIEW OF U.S. PATENT NO. 11,969,333**, and **EXHIBITS 1001-1051**, were served via Priority Mail Express on the Patent Owner at the correspondence address of record for the subject patent as follows:

Joseph Hamilton
PERKINS COIE LLP
P.O. BOX 1247
PATENT PROCUREMENT
SEATTLE, WA 98111-1247

A courtesy copy has been sent by email on this day to Patent Owner’s counsel of record in the Litigation as follows:

Amanda Tessar Email: atessar@perkinscoie.com Perkins Coie LLP 1900 Sixteenth Street, Suite 1400 Denver, CO 80202 Telephone: 303-291-2357	Ramsey M. Al-Salam Email: ralsalam@perkinscoie.com Perkins Coie LLP 1201 Third Avenue, Suite 4000 Seattle, WA 98101-3099 Telephone: 206-359-8000
Daniel T. Keese Email: DKeese@perkinscoie.com Perkins Coie LLP 1120 NW Couch Street, 10th Floor Portland, Oregon 97209-4128 Telephone: 503.757.2000 Facsimile: 503.727.2222	

Dated: May 19, 2025

By: /Joshua J. Stowell /
Joshua J. Stowell (Reg. No. 64,096)
KNOBBE MARTENS OLSON & BEAR, LLP