

Date: August 8, 2025

Filed on behalf of **Yondr, Inc.**

By: Stephen C. Jensen (Reg. No. 35,556)
Rhett D. Ramsey (Reg. No. 78,415)
KNOBBE, MARTENS, OLSON & BEAR, LLP
2040 Main Street, Fourteenth Floor
Irvine, CA 92614
Tel.: (949) 760-0404
Fax: (949) 760-9502
E-mail: YonderIPR970@knobbe.com

UNITED STATES PATENT AND TRADEMARK OFFICE

BEFORE THE PATENT TRIAL AND APPEAL BOARD

BE SMARTER, LLC AND JAMES GUERRA,
Petitioners,

v.

YONDR, INC.,
Patent Owner

Case No. IPR2025-00970
US Patent No. 9,819,788 B2

**PATENT OWNER'S BRIEF IN SUPPORT OF
DISCRETIONARY DENIAL UNDER 35 U.S.C. §314(a)**

LIST OF EXHIBITS

Exhibit	Description
2001	October 31, 2024 Complaint in Case No. 1:24-cv-01326-ADA in the U.S. District Court for the Western District of Texas
2002	December 13, 2024 Answer and Counterclaims in Case No. 1:24-cv-01326-ADA
2003	Docket Report in Case No. 1:24-cv-01326-ADA
2004	January 31, 2024 First Amended Counterclaim in Case No. 1:24-cv-01326-ADA
2005	March 24, 2025 Order Reassigning Case to Judge Alan Albright
2006	Judge Albright's Standing Order Governing Proceedings of Patent Cases ("Judge Albright's OGP")
2007	Petitioners' April 14, 2025 Invalidity Contentions in Case No. 1:24-cv-01326-ADA
2008	August 7, 2025 Scheduling Order in Case No. 1:24-cv-01326-ADA
2009	July 29, 2025 Joint Claim Construction Statement in Case No. 1:24-cv-01326-ADA
2010	U.S. Patent No. 5,977,876 ("Coleman")

TABLE OF CONENTS

	Page:
I. INTRODUCTION	1
II. THE PARALLEL DISTRICT COURT LITIGATION	1
III. INSTITUTION SHOULD BE DENIED UNDER 35 U.S.C. §314(A).....	5
A. <i>Fintiv</i> Factor 1: The Parallel District Court Litigation Is Unlikely To Be Stayed	5
B. <i>Fintiv</i> Factor 2: The District Court Trial Will Occur Before A Final Written Decision	7
C. <i>Fintiv</i> Factor 3: The Parties Have Substantially Invested In The District Court Litigation.....	8
D. <i>Fintiv</i> Factor 4: The Issues Raised In The Petition Overlap With The District Court Issues.....	10
E. <i>Fintiv</i> Factor 5: Petitioners Are The Defendants In The District Court Litigation.....	12
F. <i>Fintiv</i> Factor 6: Other Circumstances Favor Denial	12
IV. CONCLUSION.....	17

TABLE OF AUTHORITIES

Page(s):

Advanced Bionics, LLC v. MED-EL Elektromedizinische Geräte GmbH,
IPR2019-01469, Paper 6 (PTAB Feb. 13, 2020).....13

Apple Inc. v. Fintiv, Inc.,
IPR2020-00019, Paper 11 (PTAB Mar. 20, 2020).....*passim*

Dabico Airport Solutions Inc. v. AXA Power APS,
IPR-2025-00408, Paper 21 (PTAB June 18, 2025).....12

Immersion Sys. LLC v. Midas Green Techs., LLC,
IPR2021-01176, Paper 16 (PTAB Jan. 6, 2022)8

Smart Mobile Techs. LLC v. Samsung Elecs. Co.,
No. 6:21-CV-00701-ADA, 2023 WL 11999028
(W.D. Tex. Oct. 24, 2023).....5

Sonrai Memory Limited v. Micron Tech., Inc.,
No. 1:23-cv-01407-ADA, 2024 WL 5185357
(W.D. Tex. May 29, 2024).....5, 6

OTHER AUTHORITIES

15 U.S.C. §1114.....6

15 U.S.C. §1125.....6

35 U.S.C. §1022, 10

35 U.S.C. §1032, 10

35 U.S.C. §314.....*passim*

35 U.S.C. §32513, 19, 20

37 C.F.R. § 42.620

37 C.F.R. §42.2419

I. INTRODUCTION



Patent Office policy and precedent counsel against wasteful, duplicative litigation. Yet that is precisely what Petitioners request. The Board should exercise its discretion to deny institution under 35 U.S.C. §314(a) because the *Fintiv* factors strongly favor denial. The Petition raises the exact same arguments that Petitioners raise in a parallel district court litigation, where trial is expected to occur months before the statutory deadline for a final written decision. Moreover, the Petition relies on references that are cumulative of those considered during examination of the challenged claims.

Accordingly, pursuant to the Patent Office’s March 26, 2025 “Interim Processes for PTAB Workload Management,” Yondr (“PO”) respectfully requests that the Board exercise its discretion to deny this duplicative Petition that would waste the Patent Office’s and the parties’ resources.

II. THE PARALLEL DISTRICT COURT LITIGATION

On October 31, 2024, PO sued Petitioners for infringing two of PO’s patents—U.S. Patent Nos. 9,819,788 (“the ’788 Patent”) and 12,133,078 (“the ’078 Patent”) (collectively “the Asserted Patents”). EX2001. The Asserted Patents cover systems and devices for limiting the use of cell phones, particularly at communal events, to create phone-free spaces. Shown below are Figure 6 of the ’788 Patent,

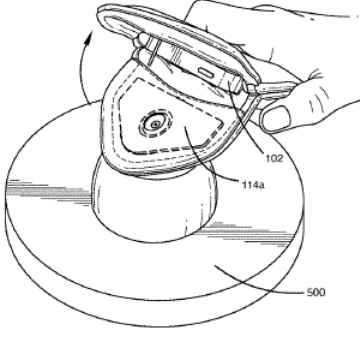
PO's patent-practicing product, and Petitioners' accused product, which by any observation copies Yondr's patented product.

'788 Patent (EX1001) FIG. 6	PO's Patent-Practicing Product (EX2001 at 8)	Petitioners' Accused Product (EX2001 at 14)
 <p>FIG. 6</p>		

On December 13, 2024, Petitioners filed an Answer and Counterclaims. EX2002. Petitioners asserted, among other things, that the '788 Patent is invalid under 35 U.S.C. §§ 102 and 103. On January 17, 2025, PO filed a Motion to Dismiss Petitioners' Counterclaims. EX2003. On January 31, 2025, Petitioners filed a First Amended Counterclaim. EX2004. In its First Amended Counterclaim, Petitioners again asserted that the '788 Patent is invalid under 35 U.S.C. §§ 102 and 103. *Id.* at 3.

On March 24, 2025, the district court case was reassigned to Judge Alan Albright. EX2005. The parties were instructed to comply with Judge Albright's Standing Order Governing Proceedings of Patent Cases ("Judge Albright's OGP"). Judge Albright's OGP is attached hereto as EX2006.

The parties also served preliminary infringement contentions and invalidity contentions in the district court proceeding. Specifically, on April 14, 2025, Petitioners served invalidity contentions relying on Samuel, Shin, and Simpson—the same references that Petitioners rely on in this IPR Petition.

Exhibit No.	Patent or Publication No.	Country of Origin	Filing Date
A-1 and B-1	2003/0011466 (“Samuel”)	USA	Feb. 15, 2001
A-2 and B-2	10-2007-0041248 (“Shin”)	Republic of Korea	Oct. 14, 2005
A-3 and B-3	2014/0298492 (“Simpson”)	USA	March 14, 2014
A-4 and B-4	2012/0187003 (“Stewart”)	USA	Jan. 21, 2011
A-5 and B-5	6,499,638 (“Campbell”)	USA	July 17, 2001
A-6 and B-6	6,218,929 (“Furuta”)	USA	June 10, 1998
A-7 and B-7 ¹	6,608,548 (“Pellaton”)	USA	May 22, 1998
A-9 and B-9	2014/0041425 (“Pinzon”)	USA	Feb. 13, 2014
A-10 and B-10	5,977,876 (“Coleman”)	USA	Nov. 2, 1999
A-11 and B-11	7,961,914 (“Smith”)	USA	June 14, 2011
A-12 and B-12	2395304 (“Metcalf”)	United Kingdom	Nov. 13, 2002
A-13 and B-13	2462725 (“Farmer”)	United Kingdom	Aug. 18, 2009
A-14 and B-14	2008/0191867 (“Markovich”)	USA	March 25, 2006
A-15 and B-15	8,950,223 (“Joyce”)	USA	Jan. 17, 2012
A-16 and B-16	6,057,779 (“Bates”)	USA	Aug. 14, 1997
A-17 and B-17	8,479,922 (“Kennedy”)	USA	Feb. 21, 2012
A-18 and B-18	2012/0061134 (“Kennedy II”)	USA	July 13, 2011
B-19	2014/122001 (“Theobald”)	WO	Jan. 20, 2014

EX2007 at 7. Petitioners raised substantially the same obviousness arguments for both the '788 and '078 Patents. *Id.* at 11-14. Petitioners also specifically incorporated any arguments that would be made in IPR proceedings into their district court contentions. *Id.* at 14.

Pursuant to Judge Albright's OGP, PO and Petitioners have also engaged in claim construction exchanges and briefing. In May 2025, the parties exchanged proposed claim constructions and supporting evidence. Throughout June and July of 2025, the parties filed their claim construction briefs. The *Markman* hearing is scheduled for September 22, 2025. EX2008.

The remaining district court deadlines in Judge Albright's OGP are triggered from the date of the *Markman* hearing. Notably, trial is expected to commence "52 weeks after *Markman* hearing (or as soon as practicable)." EX2006. Judge Albright consistently schedules trials in line with the dates specified with the OGP. Accordingly, the district court trial is expected to occur in September 2026 and is unlikely to change.

On May 6, 2025, Petitioners filed the present IPR Petition, challenging claims of the '788 Patent only. On June 10, 2025, the Patent Office accorded the Petition a filing date. Accordingly, a decision on whether to institute *inter partes* review is expected by December 10, 2025. If instituted, a final written decision would be

expected by December 10, 2026, approximately four months after the district court trial addressing the same issues raised by the Petition.

III. INSTITUTION SHOULD BE DENIED UNDER 35 U.S.C. §314(a)

A. *Fintiv* Factor 1: The Parallel District Court Litigation Is Unlikely To Be Stayed

Where the parallel district court litigation is unlikely to be stayed, this factor favors denial. *Apple Inc. v. Fintiv, Inc.*, IPR2020-00019, Paper 11 at 6-9 (PTAB Mar. 20, 2020). Despite filing the Petition months ago, Petitioners have not requested a stay in district court. Instead, Petitioners insisted on briefing claim constructions, including constructions for terms solely related to the '788 Patent. EX2009. Patent Owner likewise has not requested a stay and would oppose any such request given the myriad issues involved in the litigation, as set forth below.

Regardless, the district court litigation in this case is highly unlikely to be stayed. Judge Albright has previously and routinely denied motions to stay under similar circumstances. *See, e.g., Smart Mobile Techs. LLC v. Samsung Elecs. Co.*, No. 6:21-CV-00701-ADA, 2023 WL 11999028 (W.D. Tex. Oct. 24, 2023); *Sonrai Memory Limited v. Micron Tech., Inc.*, No. 1:23-cv-01407-ADA, 2024 WL 5185357 (W.D. Tex. May 29, 2024). For example, in *Sonrai Memory Limited v. Micron Tech., Inc.*, No. 1:23-cv-01407-ADA, 2024 WL 5185357 (W.D. Tex. May 29, 2024), Judge Albright denied the Petitioners' motion to stay pending *inter partes* review

where trial was scheduled to occur two months before a final written decision. Judge Albright explained that the district court “[a]ction is slated to resolve all the patent disputes separating the parties—either at the summary judgment stage or trial—before the PTAB adjudicates *only* invalidity based *only* on prior-art publications.” (emphasis added) *Id.* at *2. He thus found there is “little sense in putting off trial in favor of a lagging, limited adjudication that may not ultimately obviate the need for a jury trial.” *Id.*

In this case, there is even less “sense in putting off trial” than in *Sonrai* because *inter partes* review would occur several months after trial and ***undisputedly*** would not obviate the need for a jury trial. In the district court litigation, PO asserts infringement of the ’788 Patent (Count 1), infringement of the ’078 Patent (Count 2), trademark infringement under 15 U.S.C. §1114 (Count 3), unfair competition under 15 U.S.C. §1125 (Count 4), trademark infringement under Texas common law (Count 5), trade libel under Texas common law (Count 6), and unfair competition under Texas common law (Count 7). Even if the Patent Office were to institute review of the ’788 Patent, the litigation would proceed in view of the myriad remaining issues.

Petitioners also assert a variety of claims in the district court case. Petitioners assert counterclaims for declaratory judgment of invalidity of the ’788 Patent (Counterclaim 1), declaratory judgment of invalidity of the ’078 Patent

(Counterclaim 2), declaratory judgment of invalidity or unenforceability of PO's Registered Trademark No. 6,995,045 (Counterclaim 3), cancellation of the '045 Trademark (Counterclaim 4), and tortious interference with business relations and prospective business relations (Counterclaim 5).

Accordingly, *inter partes* review of the '788 Patent would have no impact on many issues raised in the district court litigation and would largely fail to simplify the district court issues. The district court, consistent with prior decisions from the same court, would likely conclude it makes "little sense in putting off trial in favor of a lagging, limited adjudication" where so many issues would not be resolved by *inter partes* review of the '788 Patent.

Because of the wide range of issues involved in the litigation and the Court's consistent practice, a stay of the district court litigation is highly unlikely. Thus, Factor 1 favors discretionary denial of the Petition.

B. *Fintiv* Factor 2: The District Court Trial Will Occur Before A Final Written Decision

"If the court's trial date is earlier than the projected statutory deadline [for a final written decision], the Board generally has weighed this fact in favor of exercising authority to deny institution[.]" *Apple Inc. v. Fintiv, Inc.*, IPR2020-00019, Paper 11 at 9 (PTAB Mar. 20, 2020). As explained above, a trial in this case is expected in September 2026 according to Judge Albright's default scheduling

procedures and the parties' jointly submitted scheduling order. There has been no indication that the district court will depart from its standard schedule in this case. Because the trial is expected to occur months before the December 10, 2026 statutory deadline for a final written decision, this factor favors denial. *See Immersion Sys. LLC v. Midas Green Techs., LLC*, IPR2021-01176, Paper 16 at 12-13 (PTAB Jan. 6, 2022) (“a jury trial...scheduled to occur in the related district court litigation approximately three months prior to when a final written decision would be statutorily due” in the IPR weighs in favor of exercising discretion to deny).

C. *Fintiv* Factor 3: The Parties Have Substantially Invested In The District Court Litigation

“[M]ore work completed by the parties and court in the parallel proceeding tends to support” a finding that “instituting would lead to duplicative costs.” *Apple Inc. v. Fintiv, Inc.*, IPR2020-00019, Paper 11 at 10 (PTAB Mar. 20, 2020). Here, this factor favors denial.

As described above, PO filed its Complaint, Petitioners filed an Answer and Counterclaims, PO filed a Motion to Dismiss Petitioners' Counterclaims, and Petitioners filed a First Amended Answer and Counterclaims. EX2003.

After the pleading stage, PO and Petitioners exchanged contentions. PO showed in detail how Petitioners' Accused CellockED Pouch infringes multiple claims of the '788 Patent and the '078 Patent. Petitioners served invalidity

contentions, which included 35 different claim charts corresponding to 18 different references. EX2007.

After serving contentions, the parties engaged in claim construction. On May 12, 2025, the parties exchanged proposed claim constructions. On May 19 the parties disclosed extrinsic evidence in support of their proposed claim constructions. On May 27 the parties met and conferred regarding claim construction. On June 6 Petitioners filed an opening claim construction brief. EX2003. On June 27 PO filed a responsive claim construction brief. *Id.* On July 11 Petitioners filed a reply claim construction brief. *Id.* On July 25 PO filed a sur-reply claim construction brief. *Id.* Although the claim construction hearing has not yet been scheduled, the timing set out in the Court's OGP indicates the claim construction hearing will likely occur long before any institution decision. The *Markman* hearing will take place on September 22, 2025. EX2008.

Moreover, the parties will incur substantial additional costs even before the institution decision date for the Petition. As set out in the Court's standing order, fact discovery will open immediately after the *Markman* hearing, and the parties must serve Final Infringement and Invalidity Contentions eight weeks after the *Markman* hearing. EX2006 at pg. 16. Thus, the parties have additional deadlines that will require a substantial investment of time to complete, even before the institution decision date. And the parties will have a substantial continuing

investment in litigating other causes of action irrespective of the review of the '788 Patent that Petitioners seek.

Because the parties have substantially invested in the district court litigation—including through multiple pleadings, infringement and invalidity contentions, and extensive claim construction briefing—this factor favors denial.

D. *Fintiv* Factor 4: The Issues Raised In The Petition Overlap With The District Court Issues

“[I]f the petition includes the same or substantially the same claims, grounds, arguments, and evidence as presented in the parallel proceeding, this fact has favored denial.” *Apple Inc. v. Fintiv, Inc.*, IPR2020-00019, Paper 11 at 12 (PTAB Mar. 20, 2020). In this case, the Petition raises exactly the same claims, grounds, arguments, and evidence as presented in the parallel proceeding. The Petition asserts the following grounds.

- Ground 1: Claim 1 of the '788 Patent is anticipated under 35 U.S.C. §102 over “Samuel”
- Ground 2: Claims 1, 3-4, and 6-7 are obvious under 35 U.S.C. §103 over “Samuel” in view of “Shin”
- Ground 3: Claims 2 and 8 are obvious under 35 U.S.C. §103 over “Samuel” in view of “Simpson” in further view of “Shin”

Petition at 8-9. But Petitioners raise those same arguments in the parallel district court litigation. Indeed, Petitioners' invalidity contentions rely on Samuel, Shin, and Simpson as the first three references. EX2007 at 7. Petitioners' invalidity contentions then refer to Samuel as an "anticipatory prior art reference" that "alone or in combination with other prior art [including Shin and Simpson] renders the Asserted Claims invalid as obvious." *Id.* at 8-12.

Accordingly, the Petition raises issues that are entirely duplicative of those raised in the parallel district court proceeding. This factor weighs very heavily in favor of denial because of Petitioners' identification of substantially the same invalidity arguments for the other patent involved in the district court litigation, the '078 Patent. The overlap in Petitioners' validity positions between the '788 Patent and the '078 Patent at the district court ensures that, if the Petition were instituted, there will be duplicative and wasteful litigation involving analogous issues with the clear potential for inconsistent factual findings between the different venues.¹ Because there will be substantial overlap between the issues presented in the Petition and at the district court, this factor favors denial.

¹ On July 29, 2025 (the last day possible) Petitioners filed a Petition for Post Grant Review against the '078 Patent. Unless *both* this Petition and the Petition for Post Grant Review are instituted, there will necessarily be litigation of overlapping factual issues at the district court in view of the nearly identical contentions filed for the '788 and '078 Patents.

E. *Fintiv* Factor 5: Petitioners Are The Defendants In The District Court Litigation

If a petitioner is unrelated to a defendant in a parallel proceeding, the Board may weigh this fact against exercising discretion to deny institution. *Apple Inc. v. Fintiv, Inc.*, IPR2020-00019, Paper 11 at 9 (PTAB Mar. 20, 2020). Here, however, Petitioners Be Smarter, LLC and James Guerra are the named defendants in the district court litigation. EX2001. This factor thus favors denial.

F. *Fintiv* Factor 6: Other Circumstances Favor Denial

The Patent Office has recently explained that “settled expectations” favor discretionary denial. *Dabico Airport Solutions Inc. v. AXA Power APS*, IPR-2025-00408, Paper 21 (PTAB June 18, 2025). In *Dabico*, “the challenged patent has been in force ***almost eight years***, creating settled expectations.” *Id.* at 3 (emphasis added). The challenged ’788 Patent issued on November 14, 2017, so it too “has been in force almost eight years.” Moreover, the accused product is, effectively, a copy of the embodiment illustrated in Figures 1-6 of the patent, which suggests that the Petitioners were aware of the ’788 Patent well before they filed the Petition. Instead of seeking review of the patent when they determined to enter the market with a copied product, Petitioners delayed filing a Petition. Thus, as in *Dabico*, settled expectations in this case favor denial.

Such settled expectations are particularly salient here because the Petition raises arguments involving references that are *less* relevant than those previously considered by the Examiner. Such issues are sometimes addressed under § 325(d). *Advanced Bionics, LLC v. MED-EL Elektromedizinische Geräte GmbH*, IPR2019-01469, Paper 6 at 7–9 (PTAB Feb. 13, 2020). But even outside of the § 325(d) framework, the Petition’s attempt to rehash the same type of arguments already considered by the Examiner weigh in favor of discretionary denial under § 314(a) because it would be a waste of Office resources and unfair to the Patent Owner.

For example, Petitioners rely on “Samuel” for all asserted grounds. Petition at 8-9. Samuel discusses a “case” wherein “non-deformable materials can be used for the walls” (e.g., a briefcase). EX1005 at ¶¶0083-0092. But Samuel is, at best, cumulative of art that the Examiner already considered. For example, during examination of the ’788 Patent, the Examiner considered U.S. Patent No. 5,977,876 (“Coleman”). Below is a comparison of the “case” illustrated in Samuel (left) and the “briefcase” illustrated in Coleman (right).

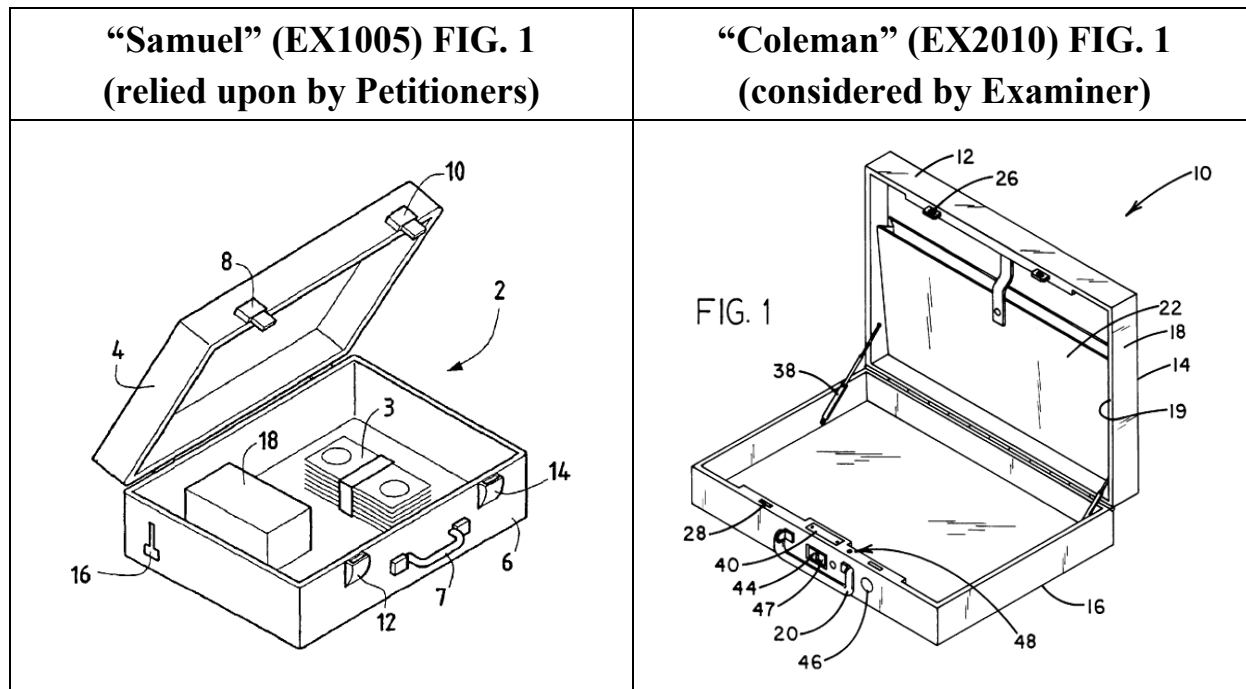

Petitioners also rely on “Shin” (EX1006)—which Petitioners describe as a “mobile phone storage envelope”—as a secondary reference. Petition at 33-34. Again, however, Shin is, at best, cumulative of the art already considered by the Examiner. For example, during examination of the ’788 Patent, the Examiner considered U.S. Patent Publication No. 2012/0187003 (“Stewart”). Below is a comparison of the envelope illustrated in Shin (left) and the system illustrated in Stewart (right).

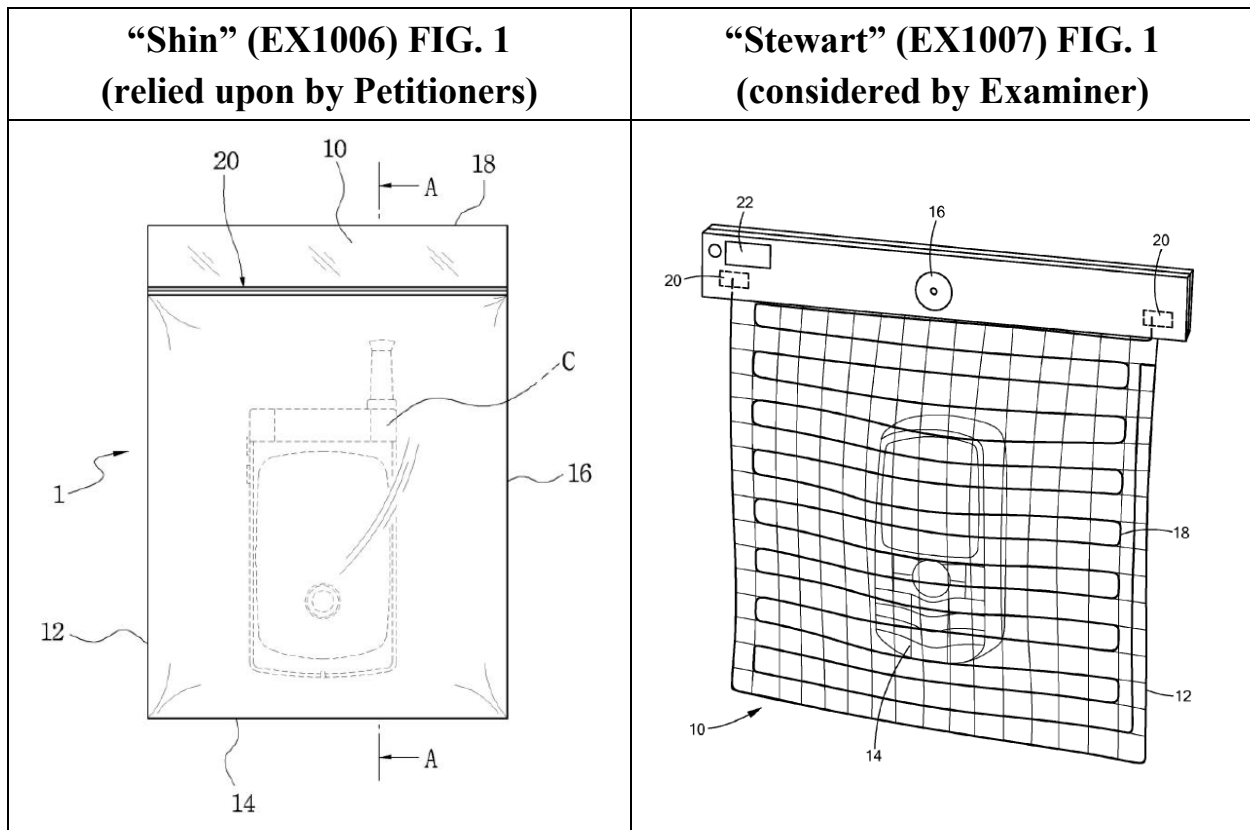

Finally, Petitioners rely on “Simpson” (EX1008)—which Petitioners describe as a “security case”—as a secondary reference. Petition at 56-59. But Simpson is, once again, cumulative of Coleman, which was already considered during examination of the ’788 Patent. Below is a comparison of the devices illustrated in Simpson (left) and Coleman (right).

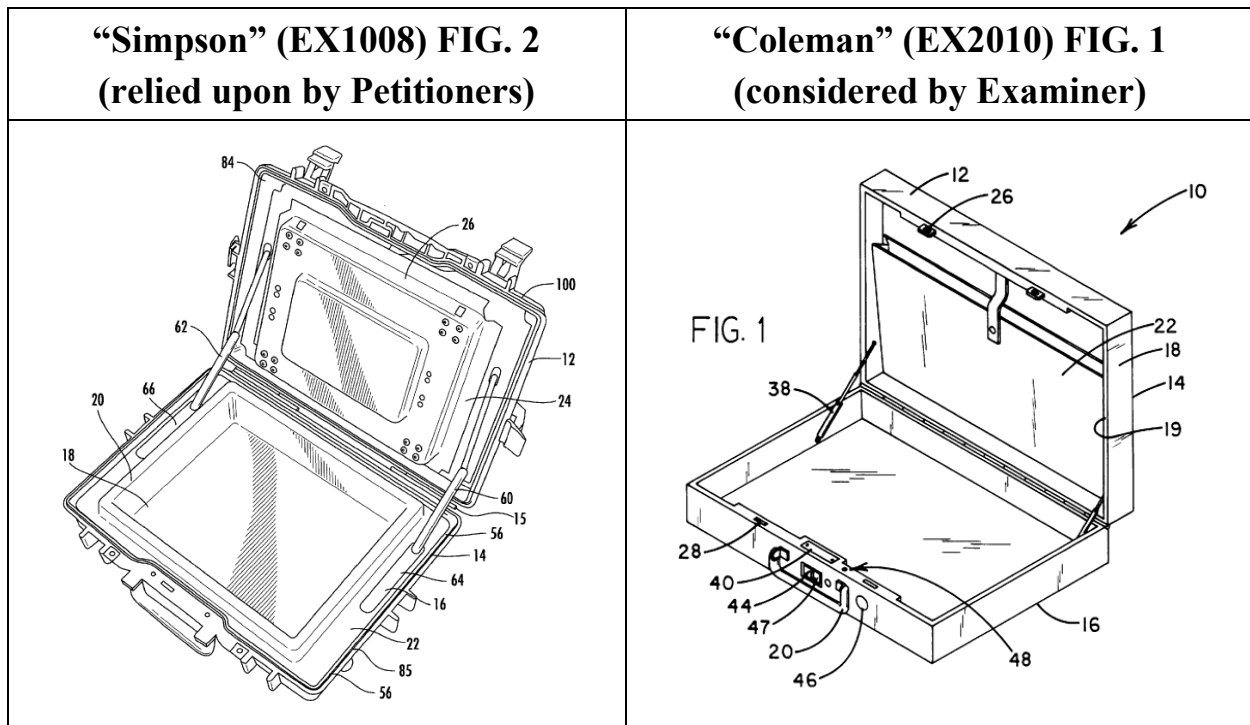

Petitioners do not explain why their proposed art is more relevant than the art already considered by the Patent Office, nor provide any indication why the Patent Office’s original judgment to issue the patent was in error. As Petitioners acknowledge, on May 5, 2017 the Examiner found that the art of record failed to disclose the limitations of then-pending claims 8, 9, and 11. The Examiner’s determination was correct. Pending claim 8 depended from claim 7 and further recited “wherein the predetermined condition is physical presence of the case outside of a defined geographical region.” EX1004. Pending claim 9 depended from claim 7 and further recited “wherein the predetermined condition is the passage of time.” *Id.* Pending claim 11 depended from claim 10 and further recited “a front and a rear panel each having first and second longitudinally opposed side edges and laterally

opposed lower edges, the first, second, and lower edges being secured together to define an opening for receiving a mobile electronic device; and a locking means for at least partially securing the opening.” *Id.* Because the art of record failed to disclose or render obvious the claimed combination of elements, the Examiner found that claims 8, 9, and 11 were allowable if rewritten in independent form. PO did so, and the challenged claims were allowed.

Petitioners’ conclusory assertion that “the Examiner erroneously indicated claims 8, 9, and 11 were allowable if re-written to independent form” (Petition at 18) fails to establish that the Examiner erred. Petitioners fail to identify any instance where the Examiner allegedly misapprehended or overlooked specific teachings of the relevant prior art or otherwise erred. The Petition asks the Office to merely reconsider the Examiner’s analysis without identifying any particular error.

Settled expectations regarding the long-issued ’788 Patent dictate that the invention is patentable over art that is, at best, cumulative of the references already considered by the Examiner during prosecution. The Petition identifies no valid reason why the cited references would have led to a different result if they were in front of the Examiner during prosecution.

IV. CONCLUSION

PO respectfully requests that the Patent Office exercise its discretion to deny institution of *inter partes* review of the ’788 Patent.

Be Smarter v. Yondr, Inc.
IPR2025-00970

Respectfully submitted,

KNOBBE, MARTENS, OLSON & BEAR, LLP

Dated: August 8, 2025 /Rhett Ramsey/
Rhett D. Ramsey (Reg. No. 78,415)
Customer No. 64,735

Attorney for Patent Owner
Yondr, Inc.

CERTIFICATE OF WORD COUNT

The undersigned certifies that the foregoing Patent Owner’s Brief In Support Of Discretionary Denial Under 35 U.S.C. §314(a) complies with the type-volume limitation in 37 C.F.R. §42.24(d) and the “Interim Processes for PTAB Workload Management” (Mar. 26, 2025). According to the word-processing system’s word count, the brief contains 3,114 words, excluding the parts of the brief exempted by 37 C.F.R. §42.24(a)(1).

KNOBBE, MARTENS, OLSON & BEAR, LLP

Dated: August 8, 2025 / Rhett Ramsey /
Rhett D. Ramsey (Reg. No. 78,415)
Customer No. 64,735

Attorney for Patent Owner
Yondr, Inc.

CERTIFICATE OF SERVICE

I hereby certify that, pursuant to 37 C.F.R. § 42.6(e) and with the agreement of counsel for Petitioner, a true and correct copy of **PATENT OWNER'S BRIEF IN SUPPORT OF DISCRETIONARY DENIAL UNDER 35 U.S.C. §314(a) and the accompanying exhibits** are being served electronically on August 8, 2025, to the e-mail addresses shown below:

Leisa Talbert Peschel JACKSON WALKER LLP 1401 McKinney, Suite 1900 Houston, TX 77010 Phone: 713-752-4278 Fax: 713-308-4178 Email: lpeschel@jw.com Email: lpeschelipdocket@jw.com	Arthur Gollwitzer III (<i>Pro Hac Vice</i>) JACKSON WALKER LLP 100 Congress Ave. Suite 1100 Austin, TX 78701 Phone: 512-236-2268 Fax: 713-308-4178 Email: agollwitzer@jw.com
---	--

KNOBBE, MARTENS, OLSON & BEAR, LLP

Dated: August 8, 2025 / Rhett Ramsey /
Rhett D. Ramsey (Reg. No. 78,415)
Customer No. 64,735

Attorney for Patent Owner
Yondr, Inc.