



US 20060182017A1

(19) **United States**

(12) **Patent Application Publication** (10) **Pub. No.: US 2006/0182017 A1**

**Hansen et al.**

(43) **Pub. Date: Aug. 17, 2006**

(54) **METHOD AND SYSTEM FOR COMPROMISE GREENFIELD PREAMBLES FOR 802.11N**

**Publication Classification**

(51) **Int. Cl.**  
*H04J 11/00* (2006.01)  
*H04B 7/00* (2006.01)  
(52) **U.S. Cl.** ..... **370/208; 370/310**

(76) Inventors: **Christopher J. Hansen**, Sunnyvale, CA (US); **Rajendra T. Moorti**, Mountain View, CA (US); **Jason A. Trachewsky**, Menlo Park, CA (US)

(57) **ABSTRACT**

Aspects of the invention described herein may enable a greenfield access mode in IEEE 802.11n WLAN systems in comparison to an alternative approach that may not provide greenfield access. The utilization of greenfield access may reduce the portion of time required to transmit data due to overhead comprising preamble fields and header fields. This may enable higher data throughput rates to be achieved. This may further enable more robust transmission of data by enabling comparable data rates to be maintained while reducing the coding rate of encoded transmitted data. The reduction of the coding rate may enable comparable data rates to be maintained for transmission via RF channels characterized by lower SNR while still achieving desired target levels of packet error rates. In another aspect of the invention, mixed mode access may be achieved while reducing the portion of time required for transmitting data due to overhead.

Correspondence Address:  
**MCANDREWS HELD & MALLOY, LTD**  
**500 WEST MADISON STREET**  
**SUITE 3400**  
**CHICAGO, IL 60661**

(21) Appl. No.: **11/151,772**

(22) Filed: **Jun. 9, 2005**

**Related U.S. Application Data**

(60) Provisional application No. 60/653,429, filed on Feb. 16, 2005.

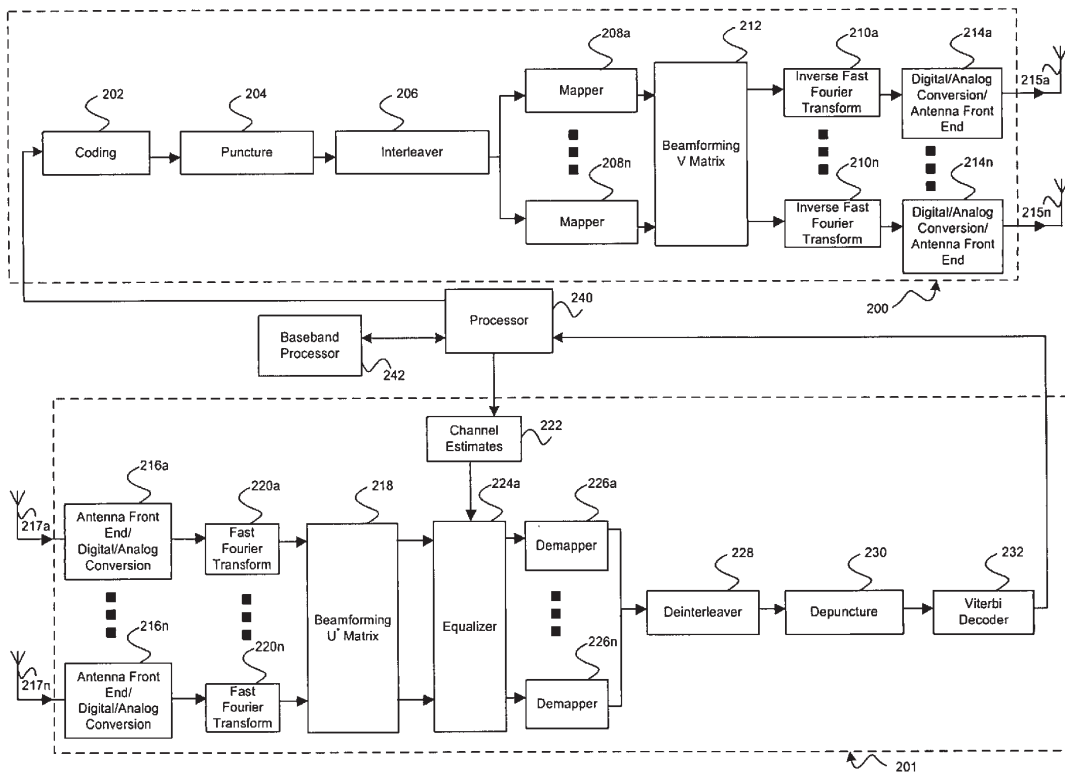

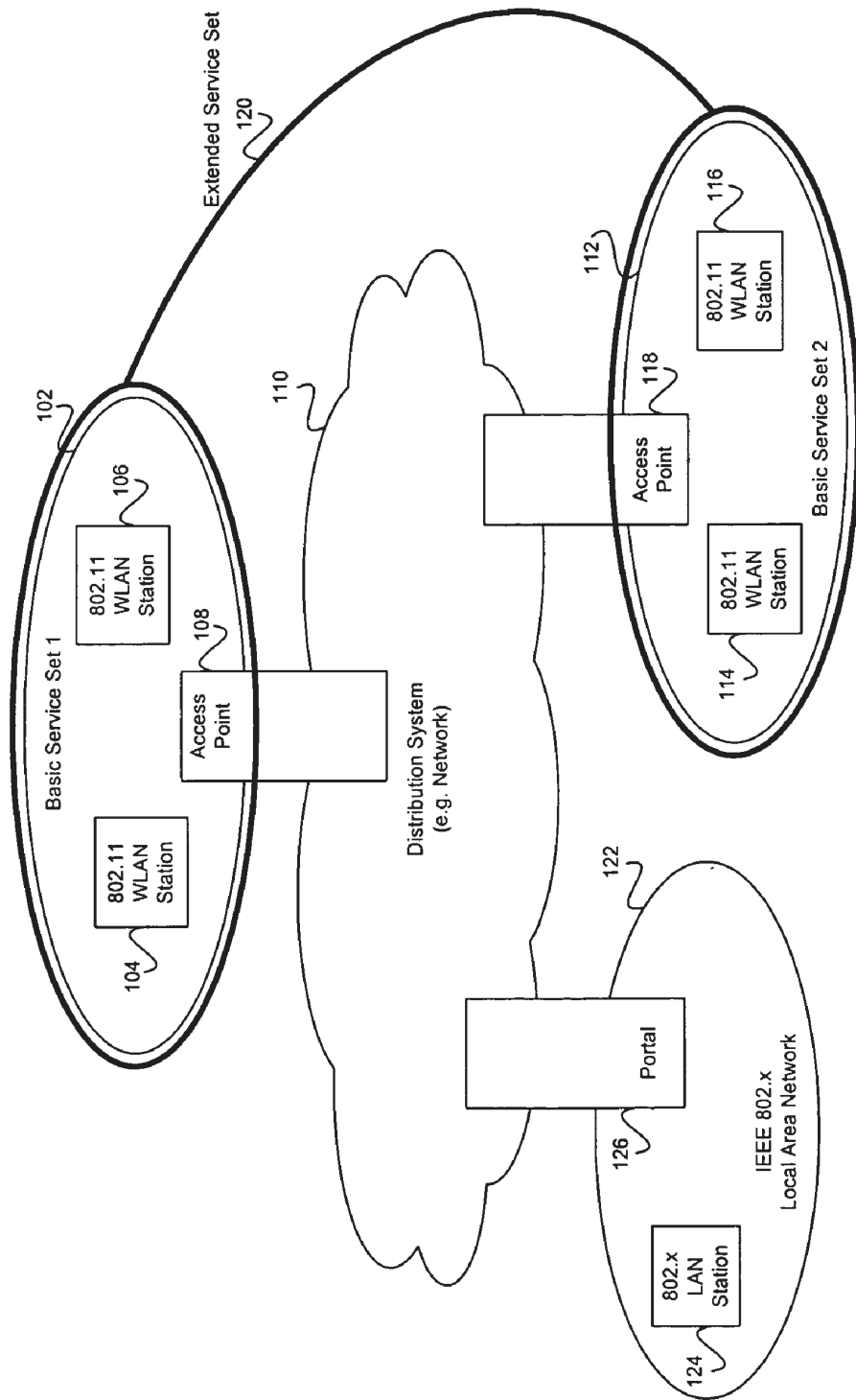

FIG. 1

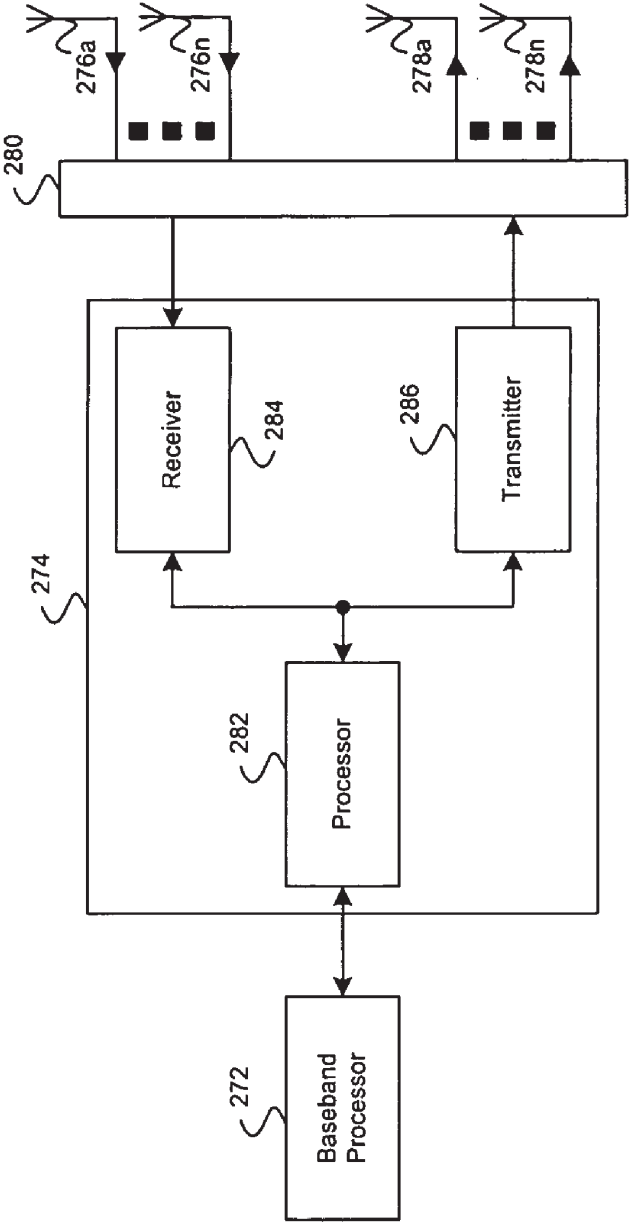

FIG. 2a

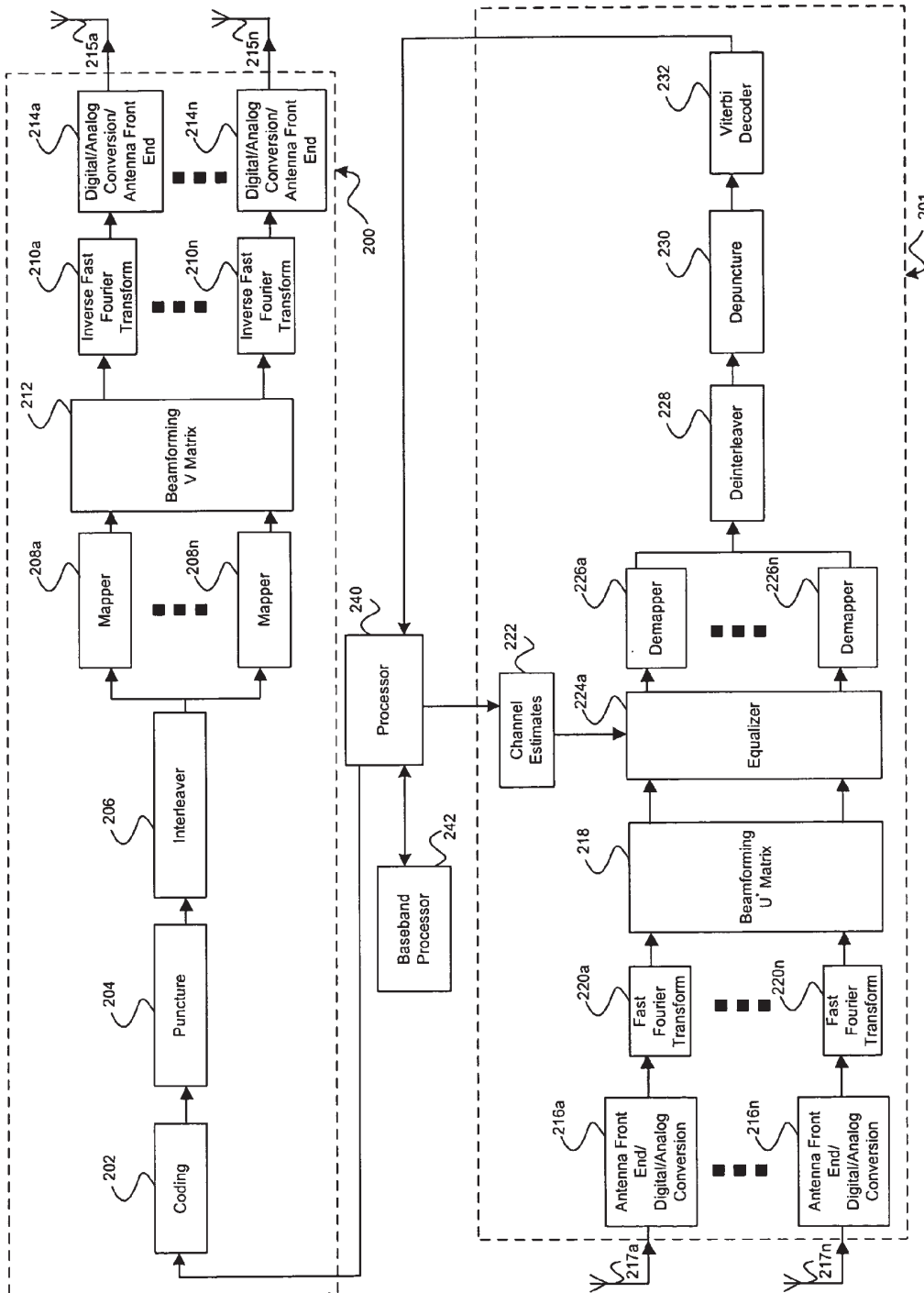

FIG. 2b

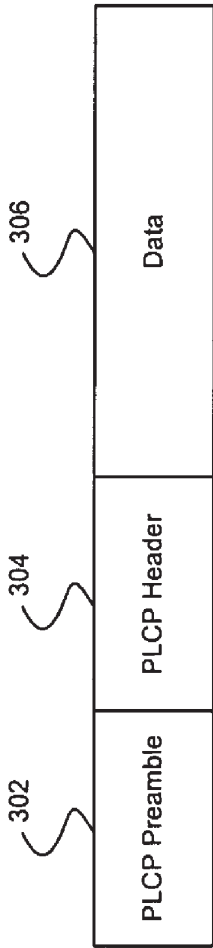

FIG. 3a

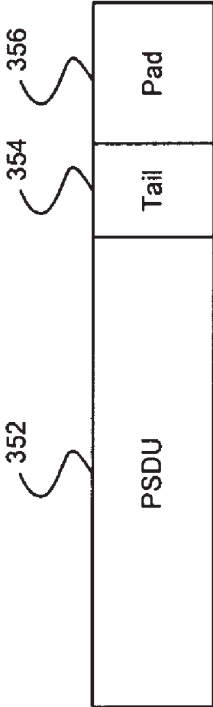

FIG. 3b

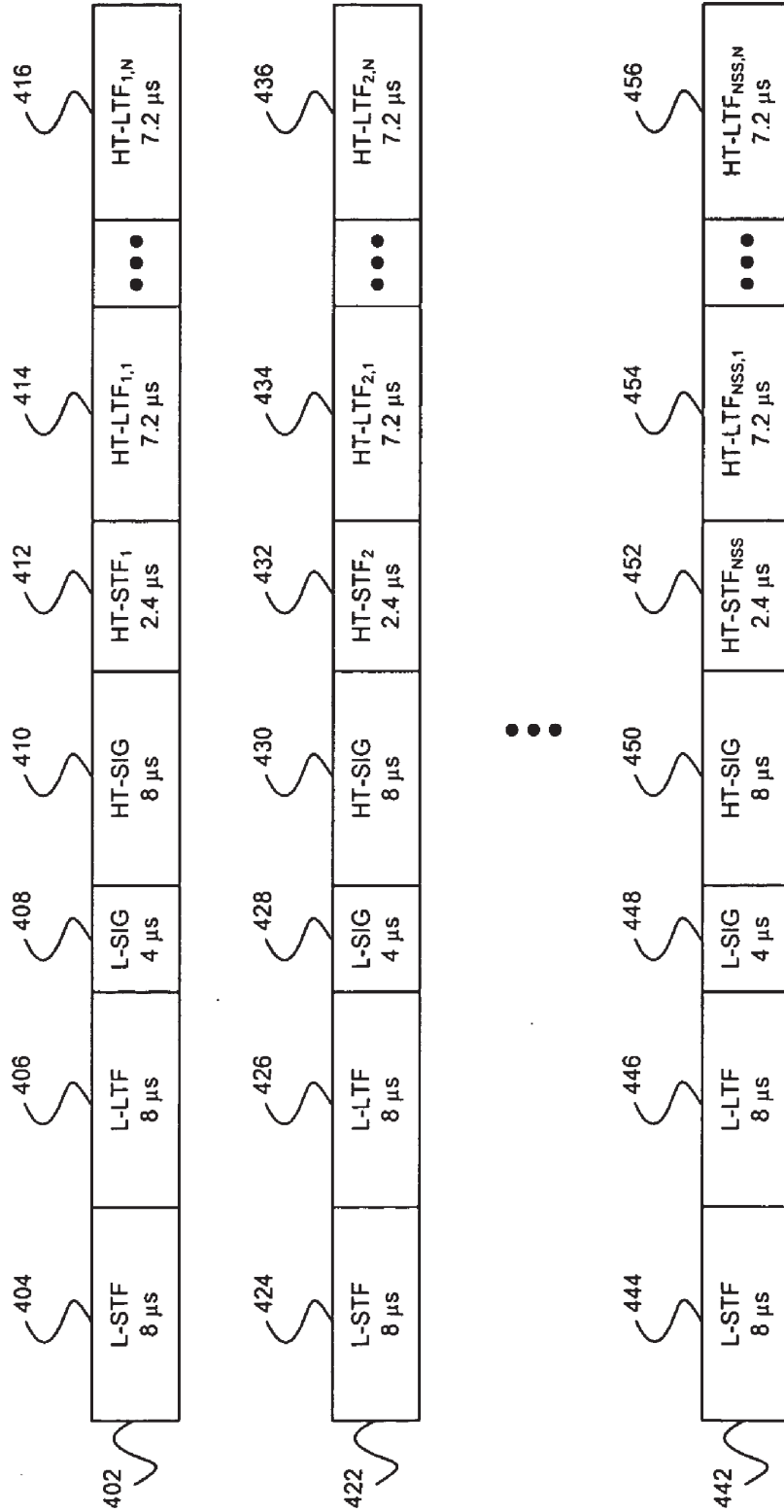

FIG. 4a

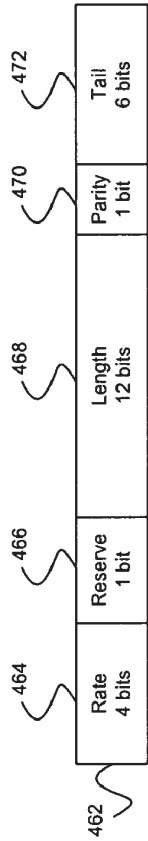

FIG. 4b

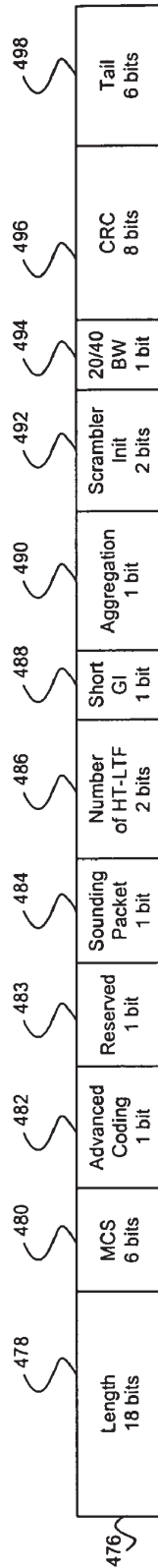

FIG. 4c

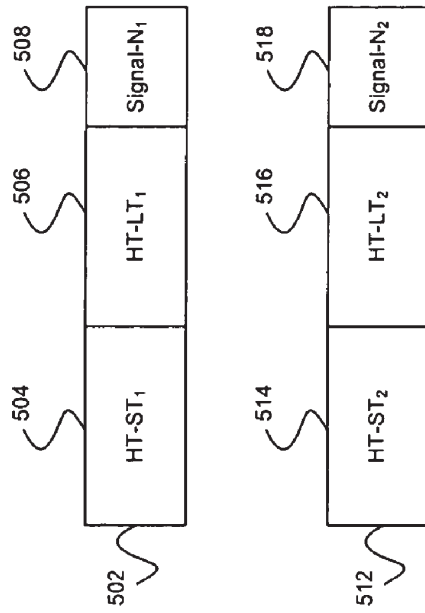

FIG. 5a

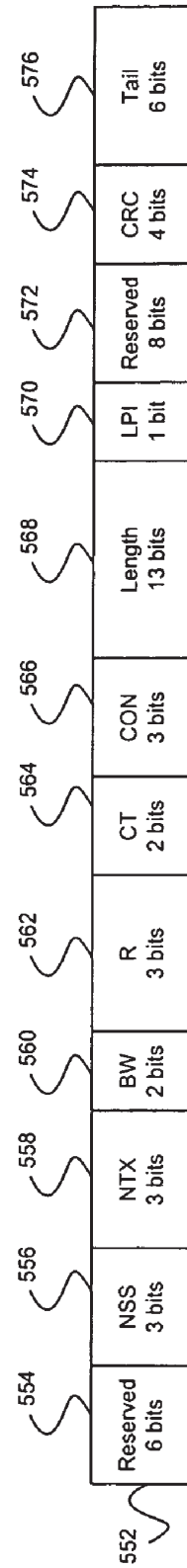

FIG. 5b

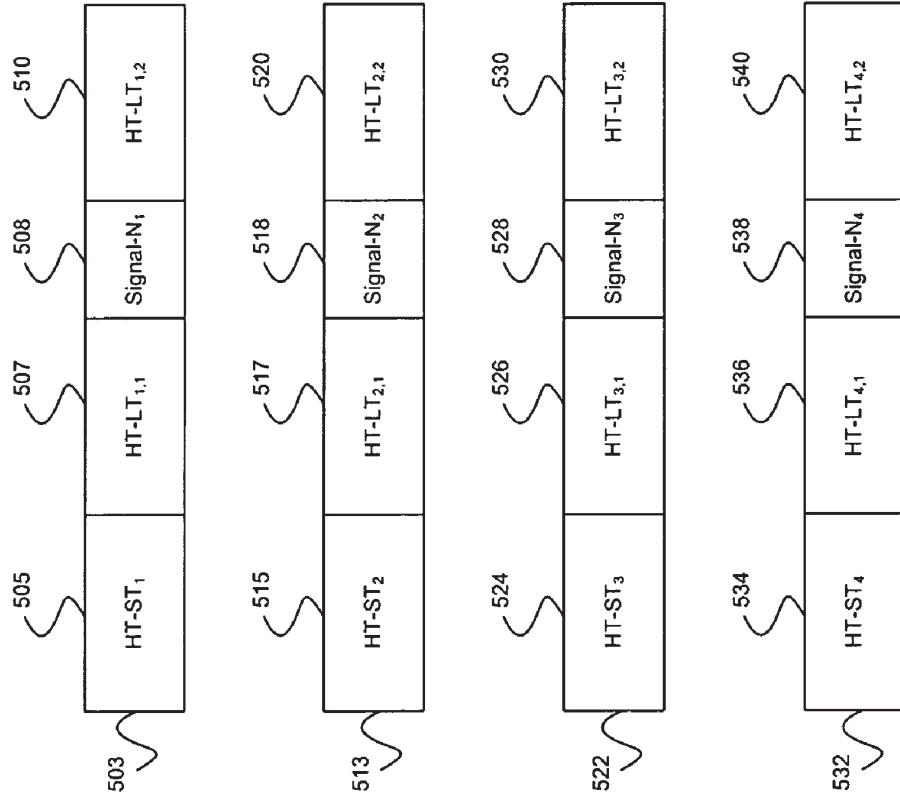

FIG. 5c

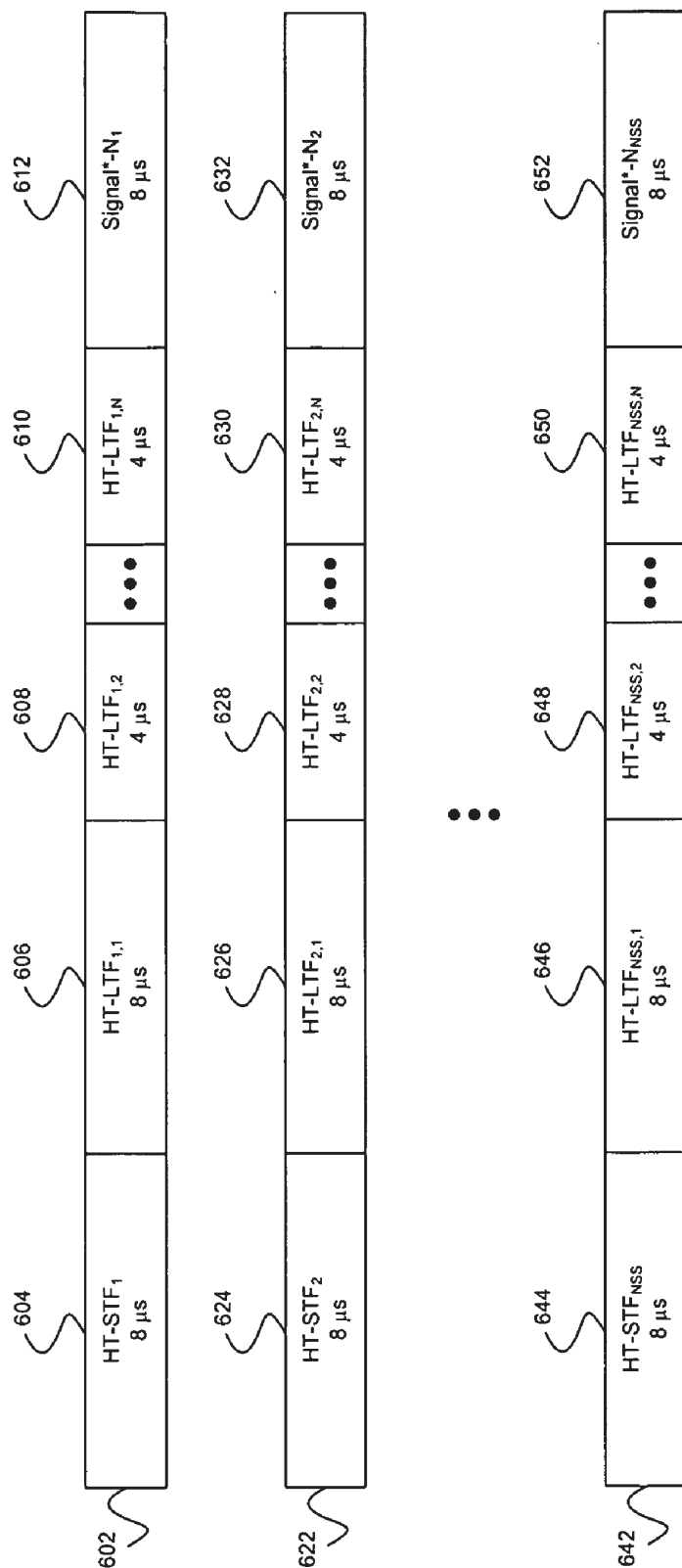

FIG. 6a

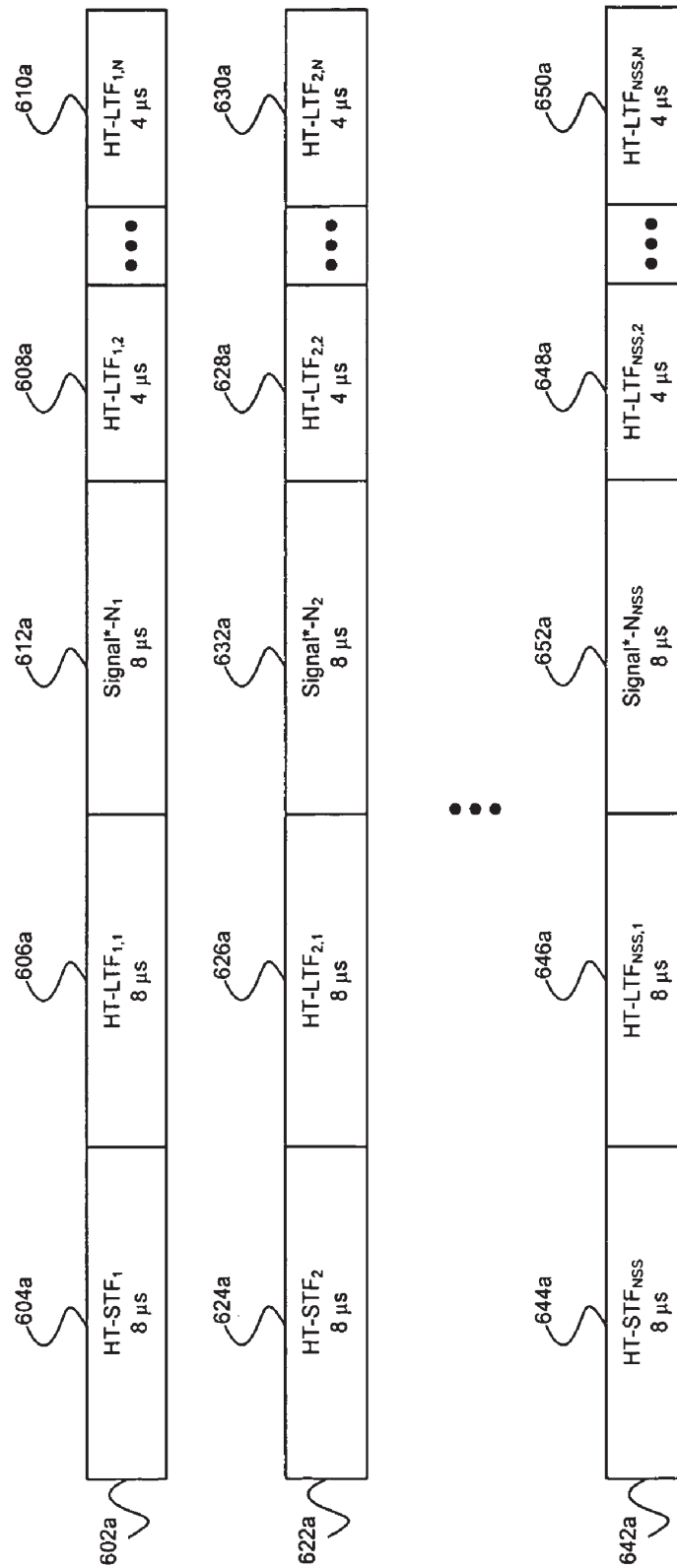

FIG. 6b

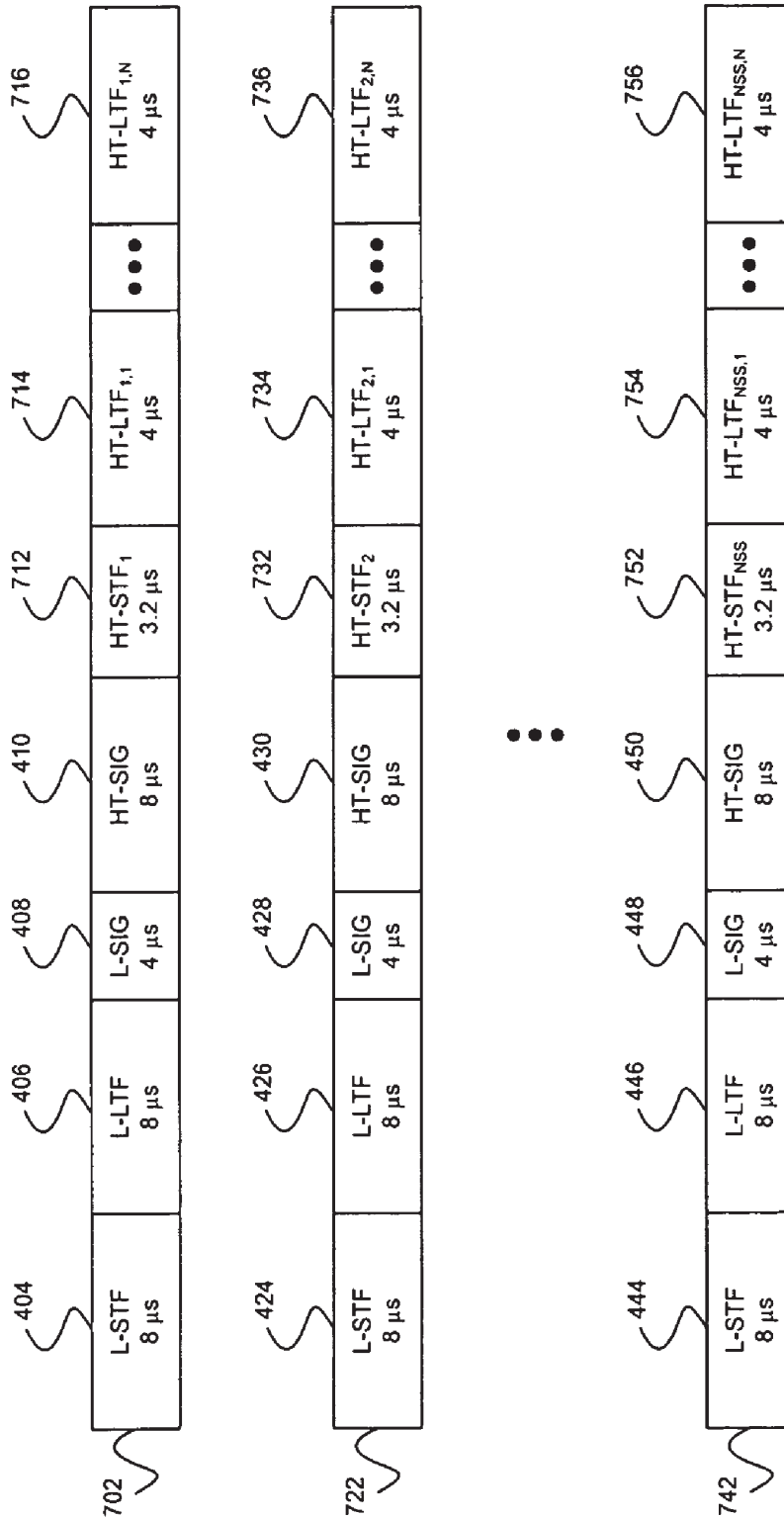

FIG. 7

**METHOD AND SYSTEM FOR COMPROMISE  
GREENFIELD PREAMBLES FOR 802.11N**

CROSS-REFERENCE TO RELATED  
APPLICATIONS/INCORPORATION BY  
REFERENCE

[0001] This application makes reference, claims priority to, and claims the benefit of U.S. Provisional Application Ser. No. 60/653,429 filed Feb. 16, 2005.

[0002] This application makes reference to:

[0003] U.S. patent application Ser. No. 10/973,595 filed Oct. 26, 2004;

[0004] U.S. patent application Ser. No. 11/052,353 filed Feb. 7, 2005; and

[0005] U.S. patent application Ser. No. 11/052,389 filed Feb. 7, 2005.

[0006] All of the above state applications are hereby incorporated herein by reference in their entirety.

FIELD OF THE INVENTION

[0007] Certain embodiments of the invention relate to wireless communication. More specifically, certain embodiments of the invention relate to a method and system for compromise greenfield preambles for 802.11n.

BACKGROUND OF THE INVENTION

[0008] Within the IEEE organization, IEEE 802.11 task group N (TGn) has been chartered to develop a standard to enable WLAN devices to achieve throughput rates beyond 100 Mbits/s. This standard may be documented in IEEE resolution 802.11n.

[0009] The Institute for Electrical and Electronics Engineers (IEEE), in resolution IEEE 802.11, also referred as "802.11", has defined a plurality of specifications which are related to wireless networking. With current existing 802.11 standards, such as 802.11(a),(b),(g), which may support up to 54 Mbps data rates, either in 2.4 GHz or in 5 GHz frequency bands. Within the IEEE organization, IEEE 802.11 task group N (TGn) has been chartered to develop a standard to enable WLAN devices to achieve throughput rates beyond 100 Mbits/s. This standard may be documented in IEEE resolution 802.11n. A plurality of proposals is emerging as candidates for incorporation in IEEE resolution 802.11n. Among them are proposals from TGn Sync, which is a multi-industry group working to define proposals for next generation wireless networks that are to be submitted for inclusion in IEEE 802.11n. The proposals may be based upon what may be referred as a "sounding frame". The sounding frame method may comprise the transmitting of a plurality of long training sequences (LTSs) that match the number of transmitting antenna at the receiving mobile terminal. The sounding frame method may not utilize beamforming or cyclic delay diversity (CDD). In the sounding frame method, each antenna in a multiple input multiple output (MIMO) system may transmit independent information.

[0010] Further limitations and disadvantages of conventional and traditional approaches will become apparent to one of skill in the art, through comparison of such systems

with some aspects of the present invention as set forth in the remainder of the present application with reference to the drawings.

BRIEF SUMMARY OF THE INVENTION

[0011] A system and/or method for compromise greenfield preambles for 802.11n, substantially as shown in and/or described in connection with at least one of the figures, as set forth more completely in the claims.

[0012] These and other advantages, aspects and novel features of the present invention, as well as details of an illustrated embodiment thereof, will be more fully understood from the following description and drawings.

BRIEF DESCRIPTION OF SEVERAL VIEWS OF  
THE DRAWINGS

[0013] **FIG. 1** is a block diagram of an exemplary system for wireless data communications, which may be utilized in accordance with an embodiment of the invention.

[0014] **FIG. 2a** is an exemplary block diagram of a transceiver which may be utilized in accordance with an embodiment of the invention.

[0015] **FIG. 2b** is an exemplary block diagram of a transceiver comprising a transmitter and a receiver in a MIMO system, which may be utilized in accordance with an embodiment of the invention.

[0016] **FIG. 3a** illustrates an exemplary physical layer protocol data unit, which may be utilized in connection with an embodiment of the invention.

[0017] **FIG. 3b** illustrates an exemplary data field in a PPDU, which may be utilized in connection with an embodiment of the invention.

[0018] **FIG. 4a** shows exemplary training fields and header fields for mixed mode access in accordance with a TGn Sync proposal that may be utilized in connection with an embodiment of the invention.

[0019] **FIG. 4b** shows an exemplary L-SIG header field for mixed mode access in accordance with a TGn Sync proposal that may be utilized in connection with an embodiment of the invention.

[0020] **FIG. 4c** shows an exemplary HT-SIG header field for mixed mode access in accordance with a TGn Sync proposal that may be utilized in connection with an embodiment of the invention.

[0021] **FIG. 5a** shows exemplary training fields and header fields for greenfield access in accordance with a WWiSE proposal for  $N_{ss}=2$ , in accordance with an embodiment of the invention.

[0022] **FIG. 5b** shows an exemplary Signal-N header field for greenfield access in accordance with a WWiSE proposal, in accordance with an embodiment of the invention.

[0023] **FIG. 5c** shows exemplary training fields and header fields for greenfield access in accordance with a WWiSE proposal for  $N_{ss}=4$ , in accordance with an embodiment of the invention.

[0024] **FIG. 6a** shows exemplary training fields and header fields with trailing signal field for greenfield access for  $N_{ss}>2$ , in accordance with an embodiment of the invention.

[0025] FIG. 6b shows exemplary training fields and header fields with early signal field for greenfield access for  $N_{ss}>2$ , in accordance with an embodiment of the invention.

[0026] FIG. 7 shows exemplary training fields and header fields for mixed mode access for  $N_{ss}>2$ , in accordance with an embodiment of the invention.

#### DETAILED DESCRIPTION OF THE INVENTION

[0027] Certain embodiments of the invention relate to a method and system for compromise greenfield preambles for 802.11n, which utilizes a channel sounding mechanism to communicate information between a transmitter and a receiver. Various embodiments of the invention may enable a greenfield access mode in IEEE 802.11n WLAN systems compared to an alternative approach that may not provide methods for greenfield access. The utilization of greenfield access may reduce the portion of time required to transmit data due to overhead comprising preamble fields and header fields. This may enable higher data throughput rates to be achieved. This may further enable more robust transmission of data by enabling comparable data rates to be maintained while reducing the coding rate of encoded transmitted data. The reduction of the coding rate may enable comparable data rates to be maintained for transmission via RF channels characterized by lower SNR while still achieving desired target levels of packet error rates.

[0028] In another embodiment of the invention, mixed mode access may be achieved while reducing a portion of time required for transmitting data due to overhead comprising preamble fields and header fields. Long training fields among a plurality of transmitted spatial streams may comprise orthonormal long training sequences, which may obviate tone interleaving. Utilizing orthonormal long training sequences may enable the transmission of identical symbols via a plurality of spatial streams.

[0029] FIG. 1 is a block diagram of an exemplary system for wireless data communications, which may be utilized in accordance with an embodiment of the invention. With reference to FIG. 1 there is shown a distribution system (DS) 110, an extended service set (ESS) 120, and an IEEE 802.x LAN 122. The ESS 120 may comprise a first basic service set (BSS) 102, and a second BSS 112. The first BSS 102 may comprise a first 802.11 WLAN station 104, a second 802.11 WLAN station 106, and an access point (AP) 108. The second BSS 112 may comprise a first 802.11 WLAN station 114, a second 802.11 WLAN station 116, and an access point (AP) 118. The IEEE 802.x LAN 122 may comprise an 802.x LAN station 124, and a portal 126.

[0030] The BSS 102 or 112 may be part of an IEEE 802.11 WLAN that comprises at least 2 IEEE 802.11 WLAN stations, for example, the first 802.11 WLAN station 104, the second 802.11 WLAN station 106, and the AP 108, which may be members of the BSS 102. Non-AP stations within BSS 102, the first 802.11 WLAN station 104, and the second 802.11 WLAN station 106, may individually form an association with the AP 108. An AP, such as AP 108, may be implemented as an Ethernet switch, bridge, or other device in a WLAN, for example. Similarly, non-AP stations within BSS 112, the first 802.11 WLAN station 114, and the second 802.11 WLAN station 116, may individually form an association with the AP 118. Once an association has been

formed between a first 802.11 WLAN station 104 and an AP 108, the AP 108 may communicate reachability information about the first 802.11 WLAN station 104 to other APs associated with the ESS 120, such as AP 118, and portals such as the portal 126. In turn, the AP 118 may communicate reachability information about the first 802.11 WLAN station 104 to stations in BSS 112. The portal 126, which may be implemented as, for example, an Ethernet switch or other device in a LAN, may communicate reachability information about the first 802.11 WLAN station 104 to stations in LAN 122 such as the 802.x LAN station 124. The communication of reachability information about the first 802.11 WLAN station 104 may enable WLAN stations that are not in BSS 102, but are associated with ESS 120, to communicate with the first 802.11 WLAN station 104.

[0031] The DS 110 may provide an infrastructure which enables a first 802.11 WLAN station 104 in one BSS 102, to communicate with a first 802.11 WLAN station 114 in another BSS 112. The DS 110 may also enable a first 802.11 WLAN station 104 in one BSS 102 to communicate with an 802.x LAN station 124 in an IEEE 802.x LAN 122, implemented as, for example a wired LAN. The AP 108, AP 118, or portal 126 may provide a means by which a station in a BSS 102, BSS 112, or LAN 122 may communicate information via the DS 110. The first 802.11 WLAN station 104 in BSS 102 may communicate information to a first 802.11 WLAN station 114 in BSS 112 by transmitting the information to AP 108, which may transmit the information via the DS 110 to AP 118, which in turn may transmit the information to station 114 in BSS 112. The first 802.11 WLAN station 104 may communicate information to the 802.x LAN station 124 in LAN 122 by transmitting the information to AP 108, which may transmit the information via the DS 110 to the portal 126, which in turn may transmit the information to the 802.x LAN station 124 in LAN 122. The DS 110 may utilize wireless communications via an RF channel, wired communications, such as IEEE 802.x Ethernet, or a combination thereof.

[0032] The IEEE resolution 802.11n may enable WLAN devices compatible with IEEE 802.11n to also interoperate with IEEE 802.11 devices that are not compatible with IEEE 802.11n. WLAN devices that are compatible with IEEE 802.11 but are not compatible with IEEE 802.11n may be referred to as legacy IEEE 802.11 WLAN devices. WLAN devices that are compatible with IEEE 802.11n and communicate with other IEEE 802.11n compatible WLAN devices in an IEEE basic service set (BSS) of which no legacy IEEE 802.11 WLAN devices are currently members may be capable of communicating in a greenfield access mode. When utilizing greenfield access, communications between the WLAN devices may utilize capabilities specified in IEEE 802.11n that may not be accessible to legacy WLAN devices. WLAN devices that are compatible with IEEE 802.11n, and that communicate with IEEE 802.11n compatible WLAN devices in an IEEE BSS, of which legacy IEEE 802.11 WLAN devices are currently members, may utilize mixed mode access. When utilizing mixed mode access, IEEE 802.11n compatible WLAN devices may utilize spoofing to avoid interference from legacy IEEE 802.11 WLAN devices during communications between IEEE 802.11n compatible devices in a BSS.

[0033] Among proposals received by TGN are proposals from, the worldwide spectrum efficiency (WWiSE) group,

and TGn Sync. Current proposals from TGn Sync may not provide a mechanism to support greenfield access. As such, mixed mode access communications based on current TGn Sync may be required to comprise information that may not be required in greenfield access communications.

**[0034]** The WWiSE proposals may comprise a plurality of enhancements to legacy IEEE 802.11 WLAN devices for incorporation in IEEE 802.11n WLAN devices. Legacy IEEE 802.11 WLAN devices may utilize 20 RF MHz channels. IEEE 802.11n may utilize 20 MHz channels, with an optional utilization of 40 RF MHz channels. Legacy IEEE 802.11 WLAN devices may utilize 52 sub-band frequencies, or subcarriers, in a 20 MHz channel, comprising pilot tones at 4 sub-band frequencies, and 48 data-bearing subcarriers. IEEE 802.11n WLAN devices based on WWiSE proposals may utilize a total of 56 subcarriers in a 20 MHz channel, comprising 2 pilot tones, and 54 data-bearing subcarriers. The subcarriers may be distributed symmetrically around a frequency that comprises the center frequency of a 20 MHz channel. The frequency spacing between subcarriers in an IEEE 802.11n WLAN device may be approximately equal to 312.5 KHz. Therefore, an IEEE 802.11n 20 MHz channel may comprise a plurality of subcarriers for which the frequency of a subcarrier,  $f_{sc}(i)$ , may be represented as:

$$f_{sc}(i)=f_{center}+i\Delta_f \text{ where,} \quad \text{equation[1]}$$

the frequency,  $f_{center}$ , may represent the center frequency in a 20 MHz channel, the frequency increment,  $\Delta_f$ , may represent the frequency spacing between subcarriers, and the value of the subcarrier index,  $i$ , may comprise a plurality of integer values represented as:

$$0 < i \leq N_{sc}/2, \text{ or} \quad \text{equation[2a]}$$

$$-N_{sc}/2 \leq i < 0, \text{ where} \quad \text{equation[2b]}$$

$N_{sc}$  may represent the number of subcarriers present in a 20 MHz channel.

**[0035]** An IEEE 802.11n 40 MHz channel may comprise a plurality of subcarriers for which the frequency of a subcarrier  $f_{sc}^{40}(i)$  may be represented as:

$$f_{sc}^{40}(i)=f_{primary}+i\Delta_f \text{ or} \quad \text{equation[3a]}$$

$$f_{sc}^{40}(i)=f_{secondary}+i\Delta_f \text{ where} \quad \text{equation[3b]}$$

$f_{primary}$  may represent the center frequency of a primary 20 MHz channel,  $f_{secondary}$  may represent the center frequency of a secondary 20 MHz channel, and the index,  $i$ , may be as defined in equations [3a and [3b]. The primary and secondary 20 MHz channels may be adjacent channels such that:

$$f_{secondary}=f_{primary} \pm 20 \text{ MHz, where} \quad \text{equation[4]}$$

the secondary 20 MHz channel may be located at an adjacent channel for which the center frequency  $f_{secondary}$  is either 20 MHz higher or 20 MHz lower than the center frequency of the primary 20 MHz channel  $f_{primary}$ . A 40 MHz channel may comprise a plurality of  $N_{sc}$  subcarriers located at the primary 20 MHz channel, and subsequent plurality of  $N_{sc}$  subcarriers located at the secondary 20 MHz channel, where  $N_{sc}$  may represent the number of subcarriers in a 20 MHz channel. In this regard, a 40 MHz channel may comprise a total of  $2N_{sc}$  subcarriers. The state of the secondary 20 MHz channel may not be evaluated during communications between IEEE 802.11n WLAN devices.

**[0036]** The WWiSE proposals may incorporate a plurality of MIMO antenna configurations represented as  $N_{TX} \times N_{RX}$ , where  $N_{TX}$  may represent the number of transmitting antenna at a station. Transmitting antennas may be utilized to transmit signals via an RF channel.  $N_{RX}$  may represent the number of receiving antenna at a station that receives the signals transmitted by the  $N_{TX}$  transmitting antenna. The MIMO antenna configuration may enable IEEE 802.11n WLAN devices to achieve higher data rates than legacy IEEE 802.11 WLAN devices. A legacy 802.11 WLAN device may achieve data rates of 54 Mbits/s based on IEEE 802.11a specifications. By comparison, an IEEE 802.11n WLAN device may achieve data rates of 540 Mbits/s in a  $4 \times 4$  MIMO configuration.

**[0037]** FIG. 2a is an exemplary block diagram of a transceiver which may be utilized in accordance with an embodiment of the invention. With reference to FIG. 2a is shown a baseband processor 272, a transceiver 274, an RF front end 280, a plurality of receive antennas 276a, . . . , 276n, and a plurality of transmitting antennas 278a, . . . , 278n. The transceiver 274 may comprise a processor 282, a receiver 284, and a transmitter 286.

**[0038]** The processor 282 may be adapted to perform digital receiver and/or transmitter functions in accordance with applicable communications standards. These functions may comprise, but are not limited to, tasks performed at lower layers in a relevant protocol reference model. These tasks may further comprise the physical layer convergence procedure (PLCP), physical medium dependent (PMD) functions, and associated layer management functions. The baseband processor 272 may be adapted to perform functions in accordance with applicable communications standards. These functions may comprise, but are not limited to, tasks related to analysis of data received via the receiver 284, and tasks related to generating data to be transmitted via the transmitter 286. These tasks may further comprise medium access control (MAC) layer functions as specified by pertinent standards.

**[0039]** The receiver 284 may be adapted to perform digital receiver functions that may comprise, but are not limited to, fast Fourier transform processing, beamforming processing, equalization, demapping, demodulation control, deinterleaving, depuncture, and decoding. The transmitter 286 may perform digital transmitter functions that comprise, but are not limited to, coding, puncture, interleaving, mapping, modulation control, inverse fast Fourier transform processing, beamforming processing. The RF front end 280 may receive analog RF signals via antennas 276a, . . . , 276n, converting the RF signal to baseband and generating a digital equivalent of the received analog baseband signal. The digital representation may be a complex quantity comprising I and Q components. The RF front end 280 may also transmit analog RF signals via an antenna 278a, . . . , 278n, converting a digital baseband signal to an analog RF signal.

**[0040]** In operation, the processor 282 may receive data from the receiver 284. The processor 282 may communicate received data to the baseband processor 272 for analysis and further processing. The baseband processor 272 may generate data to be transmitted via an RF channel by the transmitter 286. The baseband processor 272 may communicate the data to the processor 282. The processor 282 may generate a plurality of bits that are communicated to the receiver 284.

[0041] FIG. 2b is an exemplary block diagram of a transmitter and a receiver in a MIMO system, which may be utilized in accordance with an embodiment of the invention. With reference to FIG. 2b is shown a transmitter 200 a receiver 201, a processor 240, a baseband processor 242, a plurality of transmitter antennas 215a, . . . , 215n, and a plurality of receiver antennas 217a, . . . , 217n. The transmitter 200 may comprise a coding block 202, a puncture block 204, an interleaver block 206, a plurality of mapper blocks 208a, . . . , 208n, a plurality of inverse fast Fourier transform (IFFT) blocks 210a, . . . , 210n, a beamforming V matrix block 212, and a plurality of digital to analog (D/A) conversion and antenna front end blocks 214a, . . . , 214n. The receiver 201 may comprise a plurality of antenna front end and analog to digital (A/D) conversion blocks 216a, . . . , 216n, a beamforming U matrix block 218, a plurality of fast Fourier transform (FFT) blocks 220a, . . . , 220n, a channel estimates block 222, an equalizer block 224, a plurality of demapper blocks 226a, . . . , 226n, a deinterleaver block 228, a depuncture block 230, and a Viterbi decoder block 232.

[0042] The variables V and U in beamforming blocks 212 and 218 respectively refer to matrices utilized in the beamforming technique. U.S. application Ser. No. 11/052,389 filed Feb. 7, 2005, provides a detailed description of Eigen beamforming and is hereby incorporated herein by reference in its entirety.

[0043] The processor 240 may perform digital receiver and/or transmitter functions in accordance with applicable communications standards. These functions may comprise, but are not limited to; tasks performed at lower layers in a relevant protocol reference model. These tasks may further comprise the physical layer convergence procedure (PLCP), physical medium dependent (PMD) functions, and associated layer management functions. The baseband processor 242 may similarly perform functions in accordance with applicable communications standards. These functions may comprise, but are not limited to, tasks related to analysis of data received via the receiver 201, and tasks related to generating data to be transmitted via the transmitter 200. These tasks may further comprise medium access control (MAC) layer functions as specified by pertinent standards.

[0044] In the transmitter 200, the coding block 202 may transform received binary input data blocks by applying a forward error correction (FEC) technique such as, for example, binary convolutional coding (BCC). The application of FEC techniques, also known as “channel coding”, may improve the ability to successfully recover transmitted data at a receiver by appending redundant information to the input data prior to transmission via an RF channel. The ratio of the number of bits in the binary input data block to the number of bits in the transformed data block may be known as the “coding rate”. The coding rate may be specified using the notation  $i_b/t_b$ , where  $t_b$  represents the total number of bits that comprise a coding group of bits, while  $i_b$  represents the number of information bits that are contained in the group of bits  $t_b$ . Any number of bits  $t_b - i_b$  may represent redundant bits that may enable the receiver 201 to detect and correct errors introduced during transmission. Increasing the number of redundant bits may enable greater capabilities at the receiver to detect and correct errors in information bits. The penalty for this additional error detection and correction capability may result in a reduction in the information transfer rates

between the transmitter 200 and the receiver 201. The invention is not limited to BCC and a plurality of coding techniques such as, for example, Turbo coding, or low density parity check (LDPC) coding may also be utilized.

[0045] The puncture block 204 may receive transformed binary input data blocks from the coding block 202 and alter the coding rate by removing redundant bits from the received transformed binary input data blocks. For example, if the coding block 202 implemented a  $1/2$  coding rate, 4 bits of data received from the coding block 202 may comprise 2 information bits, and 2 redundant bits. By eliminating 1 of the redundant bits in the group of 4 bits, the puncture block 204 may adapt the coding rate from  $1/2$  to  $2/3$ . The interleaver block 206 may rearrange bits received in a coding rate-adapted data block from the puncture block 204 prior to transmission via an RF channel to reduce the probability of uncorrectable corruption of data due to burst of errors, impacting contiguous bits, during transmission via an RF channel. The output from the interleaver block 206, may also be divided into a plurality of streams where each stream may comprise a non-overlapping portion of the bits from the received coding rate-adapted data block. Therefore, for a given number of bits in the coding rate-adapted data block,  $b_{db}$ , a given number of streams from the interleaver block 206,  $n_{st}$ , and a given number of bits assigned to an individual stream  $i$  by the interleaver block 206,  $b_{st}(i)$ :

$$b_{db} = \sum_{i=1}^{n_{st}} b_{st}(i) \quad \text{equation [5]}$$

[0046] The plurality of mapper blocks 208a, . . . , 208n may comprise a number of individual mapper blocks that is equal to the number of individual streams generated by the interleaver block 206. Each individual mapper block 208a, . . . , 208n may receive a plurality of bits from a corresponding individual stream, mapping those bits into a “symbol” by applying a modulation technique based on a “constellation” utilized to transform the plurality of bits into a signal level representing the symbol. The representation of the symbol may be a complex quantity comprising in-phase (I) and quadrature (Q) components. The mapper block 208a, . . . 208n for stream  $i$  may utilize a modulation technique to map a plurality of bits,  $b_{st}(i)$ , into a symbol.

[0047] The beamforming V matrix block 212 may apply the beamforming technique to the plurality of symbols, or “spatial modes”, generated from the plurality of mapper blocks 208a, . . . , 208n. The beamforming V matrix block 212 may generate a plurality of signals where the number of signals generated may be equal to the number of transmitting antenna at the transmitter 200. Each signal in the plurality of signals generated by the beamforming V block 212 may comprise a weighted sum of at least one of the received symbols from the mapper blocks 208a, . . . , 208n.

[0048] The plurality of IFFT blocks 210a, . . . , 210n may receive a plurality of signals from the beamforming block 212. Each IFFT block 210a, . . . , 210n may subdivide the bandwidth of the RF channel into a plurality of  $n$  sub-band frequencies to implement orthogonal frequency division multiplexing (OFDM), buffering a plurality of received signals. Each buffered signal may be modulated by a carrier

signal whose frequency is based on one of the sub-bands. Each of the IFFT blocks **210a**, . . . , **210n** may then independently sum their respective buffered and modulated signals across the frequency sub-bands to perform an n-point IFFT, thereby generating a composite OFDM signal.

[0049] The plurality of digital (D) to analog (A) conversion and antenna front end blocks **214a**, . . . , **214n** may receive the plurality of signals generated by the plurality of IFFT blocks **210a**, . . . , **210n**. The digital signal representation received from each of the plurality of IFFT blocks **210a**, . . . , **210n** may be converted to an analog RF signal that may be amplified and transmitted via an antenna. The plurality of D to A conversion and antenna front end blocks **214a**, . . . , **214n** may be equal to the number of transmitting antenna **115a**, . . . , **115n** at the transmitter **200**. Each D to A conversion and antenna front end block **214a**, . . . , **214n** may receive one of the plurality of signals from the beamforming V matrix block **212** and may utilize an antenna **115a**, . . . , **115n** to transmit one RF signal via an RF channel.

[0050] In the receiver **201**, the plurality antenna front end and A to D conversion blocks **216a**, . . . , **216n** may receive analog RF signals via an antenna, converting the RF signal to baseband and generating a digital equivalent of the received analog baseband signal. The digital representation may be a complex quantity comprising I and Q components. The number of antenna front end and A to D conversion blocks **216a**, . . . , **216n** may be equal to the number of receiving antenna **117a**, . . . , **117n** at the receiver **201**.

[0051] The plurality of FFT blocks **220a**, . . . , **220n** may receive a plurality of signals from the plurality of antenna front end and A to D conversion blocks **216a**, . . . , **216n**. The plurality of FFT blocks **220a**, . . . , **220n** may be equal to the number of antenna front end and A to D conversion blocks **216a**, . . . , **216n**. Each FFT block **220a**, . . . , **220n** may receive a signal from an antenna front end and A to D conversion block **216a**, . . . , **216n**, independently applying an n-point FFT technique, demodulating the signal by a plurality of carrier signals based on the n sub-band frequencies utilized in the transmitter **200**. The demodulated signals may be mathematically integrated over one sub band frequency period by each of the plurality of FFT blocks **220a**, . . . , **220n** to extract n symbols contained in each of the plurality of OFDM signals received by the receiver **201**.

[0052] The beamforming U\* block **218** may apply the beamforming technique to the plurality of signals received from the plurality of FFT blocks **220a**, . . . , **220n**. The beamforming U\* block **218** may generate a plurality of signals where the number of signals generated may be equal to the number of streams utilized in generating the signals at the transmitter **200**. Each of the plurality of signals generated by the beamforming U\* block **218** may comprise a weighted sum of at least one of the signals received from the FFT blocks **220a**, . . . , **220n**.

[0053] The channel estimates block **222** may utilize preamble information contained in a received RF signal to compute channel estimates. The plurality of equalizer block **224** may receive signals generated by the beamforming U\* block **218**. The equalizer block **224** may process the received signals based on input from the channel estimates block **222** to recover the symbol originally generated by the transmitter **200**. The equalizer block **224** may comprise suitable logic, circuitry, and/or code that may be adapted to

transform symbols received from the beamforming U\* block to compensate for fading in the RF channel.

[0054] The plurality of demapper blocks **226a** . . . **226n** may receive symbols from the plurality of equalizer blocks **224a** . . . **224n**, reverse mapping each symbol to a plurality of bits by applying a demodulation technique, based on the modulation technique utilized in generating the symbol at the transmitter **200**, to transform the symbol into a plurality of bits. The plurality of demapper blocks **226a** . . . **226n** may be equal to the number of equalizer blocks **224a** . . . **224n**, which may also be equal to the number of streams in the transmitter **200**.

[0055] The deinterleaver block **228** may receive a plurality of bits from each of the demapper blocks **226a** . . . **226n**, rearranging the order of bits among the received plurality of bits. The deinterleaver block **228** may rearrange the order of bits from the plurality of demapper blocks **226a** . . . **226n** in, for example, the reverse order of that utilized by the interleaver **206** in the transmitter **200**. The depuncture block **230** may insert "null" bits into the output data block received from the deinterleaver block **228** that were removed by the puncture block **204**. The Viterbi decoder block **232** may decode a depunctured output data block, applying a decoding technique that may recover the binary data blocks that were input to the coding block **202**.

[0056] In operation, the processor **240** may receive decoded data from the Viterbi decoder **232**. The processor **240** may communicate received data to the baseband processor **242** for analysis and further processing. The processor **240** may also communicate data received via the RF channel, by the receiver **201**, to the channel estimates block **222**. This information may be utilized by the channel estimates block **222**, in the receiver **201**, to compute channel estimates for a received RF channel. The baseband processor **242** may generate data to be transmitted via an RF channel by the transmitter **200**. The baseband processor **242** may communicate the data to the processor **240**. The processor **240** may generate a plurality of bits that are communicated to the coding block **202**.

[0057] The elements shown in FIG. 2b may comprise components that may be present in an exemplary embodiment of a wireless communications terminal. One exemplary embodiment of a may be a wireless communications transmitter comprising a transmitter **200**, a processor **240**, and a baseband processor **242**. Another exemplary embodiment of a may be a wireless communications receiver comprising a receiver **201**, a processor **240**, and a baseband processor **242**. Another exemplary embodiment of a may be a wireless communications transceiver comprising a transmitter **200**, a receiver **201**, a processor **240**, and a baseband processor **242**.

[0058] Various embodiments of a MIMO system in an  $N_{TX} \times N_{RX}$  antenna configuration may comprise a plurality of  $N_{TX}$  digital to analog conversion and antenna front end blocks **214a** . . . **214n**, and a plurality of  $N_{RX}$  antenna front end and analog to digital conversion blocks **216a** . . . **216n**.

[0059] FIG. 3a illustrates an exemplary physical layer protocol data unit, which may be utilized in connection with an embodiment of the invention. With reference to FIG. 3a there is shown a physical layer convergence protocol (PLCP) preamble field **302**, a PLCP header field **304**, and a

data field **306**. The preamble field **302** may be utilized by a receiver **201** in connection with the reception of signals via an RF channel. The header field **304** may comprise information that is utilized by a receiver **201** in connection with the processing of information in the data field **306**. The data field **306** may comprise information that is transmitted by a transmitter **200** and received by a receiver **201**.

[0060] **FIG. 3b** illustrates an exemplary data field in a PPDU, which may be utilized in connection with an embodiment of the invention. With reference to **FIG. 3b** there is shown a physical layer service data unit (PSDU) field **352**, a tail field **354**, and a pad field **356**. In an exemplary data field, as shown in **FIG. 3b**, the PSDU may comprise a media access control (MAC) layer frame received from the MAC layer in the IEEE 802.11 protocol stack. In an exemplary PPDU, as shown in **FIG. 3a**, the data field **306** may comprise 1,500 octets of binary data. The tail field **354** may comprise a plurality of bits, the number of which may depend upon the methods utilized to process the PSDU. The pad field **356** may comprise a plurality of bits, the number of which may depend upon a desired number of bits to be comprised in the data field.

[0061] **FIG. 4a** shows exemplary training fields and header fields for mixed mode access in accordance with a TGn Sync proposal that may be utilized in connection with an embodiment of the invention. With reference to **FIG. 4a** there is shown a plurality of PPDU preambles and headers **402**, **422**, and **442**. The preamble and header **402** may comprise a legacy short training field (L-STF) **404**, a legacy long training field (L-LTF) **406**, a legacy signal field (L-SIG) **408**, a high throughput signal field (HT-SIG) **410**, a high throughput short training field for the first spatial stream (HT-STF<sub>1</sub>) **412**, and a plurality of high throughput long training fields for the first spatial stream comprising training fields number **1** through **N** (HT-LTF<sub>1,1</sub> . . . HT-LTF<sub>1,N</sub>) **414** . . . **416**. The integer value **N** may represent the number of long training fields contained in the preamble and header **402**.

[0062] Each of the legacy short training fields, L-STF **404**, **424**, and **444** may be approximately 8  $\mu$ s in duration, or equivalent in time duration to 2 IEEE 802.11n OFDM symbols and corresponding guard interval times, where each symbol and guard interval may be of approximately 4  $\mu$ s in duration. Each of the long training fields, L-LTF **406**, **426**, and **446** may be approximately 8  $\mu$ s in duration, or equivalent in time duration to 2 IEEE 802.11n OFDM symbols and corresponding guard intervals. Each of the signal fields L-SIG **408**, **428**, and **448** may be approximately 4  $\mu$ s in duration, or equivalent in time duration to 1 IEEE 802.11n OFDM symbol and corresponding guard interval. Each of the high throughput HT-SIG fields **410**, **430**, and **450** may be approximately 8  $\mu$ s in duration, or equivalent in time duration to 2 IEEE 802.11n OFDM symbols and corresponding guard intervals. Each of the HT-STF fields **412**, **432**, and **452** may be approximately 2.4  $\mu$ s in duration. Each of the plurality of HT-LTF<sub>1,1</sub> . . . HT-LTF<sub>1,N</sub>, HT-LTF<sub>2,1</sub> . . . HT-LTF<sub>2,N</sub>, . . . , HT-LTF<sub>NSS,1</sub> . . . HT-LTF<sub>NSS,N</sub> fields **414** . . . **416**, **434** . . . **436**, . . . , **454** . . . **456** may be approximately 7.2  $\mu$ s in duration.

[0063] The preamble and header **422** may comprise a legacy short training field **424**, a legacy long training field **426**, a legacy signal field **428**, a high throughput signal field

**430**, a high throughput short training field for the second spatial stream **432**, and a plurality of high throughput long training fields for the second spatial stream comprising training fields number **1** through **N** **434** . . . **436**. The preamble and header **442** may comprise a legacy short training field **444**, a legacy long training field **446**, a legacy signal field **448**, a high throughput signal field **450**, a high throughput short training field for spatial stream number  $N_{SS}$  **452**, and a plurality of high throughput long training fields for spatial stream number  $N_{SS}$  comprising training sequence fields number **1** through **N** **454** . . . **456**.

[0064] In operation, the integer value  $N_{SS}$  may represent the number of spatial streams transmitted from a plurality of  $N_{TX}$  antennas located at a WLAN station. The number long training fields, **N**, may be approximately equal to the number of spatial streams  $N_{SS}$ . The training field L-STF **424** may represent a time shifted version of the training field L-STF **404** based on a method such as cyclical diversity delay (CDD). The training field L-STF **444** may represent a CDD version of the training field L-STF **424**. The training field L-LTF **426** may represent a CDD version of the training field L-LTF **406**. The training field L-LTF **446** may represent a CDD version of the training field L-LTF **426**. The signal field L-SIG **428** may represent a CDD version of the signal field L-SIG **408**. The signal field L-SIG **448** may represent a CDD version of the signal field L-SIG **428**. The signal field HT-SIG **430** may represent a CDD version of the signal field HT-SIG **410**. The signal field HT-SIG **450** may represent a CDD version of the signal field HT-SIG **430**.

[0065] The plurality of high throughput short training fields comprising HT-STF<sub>1</sub> **412**, HT-STF<sub>2</sub> **432**, and HT-STF<sub>NSS</sub> **452** may utilize tone interleaving. In the tone interleaving procedure, a plurality of  $N_{TT}$  frequencies, or tones, from among the plurality of subcarrier frequencies within a 20 MHz or 40 MHz RF channel, may be utilized for transmission within a given training field, for example, the high throughput short training field **412**, **432**, or **452** transmitted via each of a plurality of  $N_{SS}$  spatial streams. Tones may be interleaved by dividing the plurality  $N_{TT}$  tones into a plurality of tone groups each comprising a plurality  $N_T/N_{SS}$  tones such that no tone group comprises a tone whose frequency is approximately equal to the frequency of a tone in another tone group. The HT-STF<sub>1</sub> may utilize tones from the first tone group, the HT-STF<sub>2</sub> may utilize tones from the second tone group, and so forth. Similarly, the plurality of long training fields HT-LTF<sub>1,1</sub> **414**, HT-LTF<sub>2,1</sub> **434**, and HT-LTF<sub>NSS,1</sub> **454**, may utilize tone interleaving. The plurality of long training fields HT-LTF<sub>1,N</sub> **416**, HT-LTF<sub>2,N</sub> **436**, and HT-LTF<sub>NSS,N</sub> **456**, may utilize tone interleaving.

[0066] **FIG. 4b** shows an exemplary L-SIG header field for mixed mode access in accordance with a TGn Sync proposal that may be utilized in connection with an embodiment of the invention. With reference to **FIG. 4b**, there is shown a L-SIG header **462**. The L-SIG header **462** may comprise a rate field **464**, a reserve field **466**, a length field **468**, a parity field **470**, and a tail field **472**. The L-SIG header **462** may comprise 24 bits of binary information. The rate field **464** may comprise 4 bits of binary information. The reserve field **466** may comprise 1 bit of binary information. The length field **468** may comprise 12 bits of binary infor-

mation. The parity field 470 may comprise 1 bit of binary information. The tail field 472 may comprise 6 bits of binary information.

[0067] FIG. 4c shows an exemplary HT-SIG header field for mixed mode access in accordance with a TGn Sync proposal that may be utilized in connection with an embodiment of the invention. With reference to FIG. 4c, there is shown an HT-SIG header field 476. The HT-SIG header may comprise a length field 478, a modulation and coding scheme (MCS) field 480, an advanced coding field 482, a reserved field 483, a sounding packet field 484, a number of HT-LTF field 486, a short guard interval (GI) field 488, an aggregation field 490, a scrambler initialization field 492, a 20 MHz or 40 MHz bandwidth (BW) field 494, a cyclical redundancy check field 496, and a tail field 498. The length field 478 may comprise 18 bits of binary information. The length field 478 may indicate the number of octets of binary information that is contained in the physical layer service data unit (PSDU) field 352 in the corresponding physical layer protocol data unit (PPDU). The MCS field 480 may comprise 6 bits of binary information. The MCS field 480 may indicate the modulation type and coding rate being utilized in the coding of the corresponding PPDU. The advanced coding field 482 may comprise 1 bit of binary information. The advanced coding field 482 may indicate whether binary convolutional coding (BCC), or low density parity check (LDPC) coding is utilized in the coding of the corresponding PPDU. The reserved field 483 may comprise 1 bit of binary information. The reserved field 483 may comprise no assigned utilization.

[0068] The sounding packet field 484 may comprise, for example, 1 bit of binary information. The sounding packet field 484 may indicate whether the corresponding PSDU may be utilized for closed loop calibration between a transmitter and a receiver. The number of HT-LTF field 486 may comprise 2 bits of binary information. The number of HT-LTF field 486 may indicate the number of high throughput long training fields contained in the corresponding PPDU. The short GI field 488 may comprise 1 bit of binary information. The short GI field 488 may indicate the length of the guard interval utilized when transmitting the data field 206 in the corresponding PPDU. The aggregation field 490 may comprise 1 bit of binary information. The aggregation field 490 may indicate whether the data field 306 in the corresponding PPDU comprises the last portion of a message. The scrambler init field 492 may comprise 2 bits of binary information. The scrambler init field 492 may be utilized to initialize a scrambler function at the WLAN station receiving the PPDU. The 20 MHz or 40 MHz bandwidth field 494 may comprise 1 bit of binary information. The 20 MHz or 40 MHz bandwidth field 494 may indicate whether the PPDU was transmitted utilizing a 20 MHz RF channel, or a 40 MHz RF channel. The CRC field 496 may comprise 8 bits of binary information. The CRC field 496 may be utilized for detecting and/or correcting errors in a received corresponding PPDU. The tail field 498 may comprise 6 bits of binary information. The tail field 498 may be utilized to extend the number of binary bits contained in an HT-SIG field to a desired length.

[0069] In an exemplary PPDU comprising 1,500 binary octets of data 306 (FIG. 3a), the data may comprise a time period of approximately 13 IEEE 802.11n OFDM symbols and corresponding guard bands in duration. This may be

based on transmitting at a data rate of 243 Mbits/s while utilizing 2 spatial streams, 40 MHz bandwidth, 64 QAM modulation type, and a coding rate of  $\frac{3}{4}$ . Each OFDM symbol per spatial stream may comprise 486 bits of binary information for a combined 972 bits for the simultaneously transmitted OFDM symbols among the 2 spatial streams. The number of binary bits contained in an OFDM symbol,  $N_{DBPS}$ , may be determined based on:

$$N_{DBPS} = N_{DSC} * N_B(CON) * R, \text{ where} \quad \text{equation}[6]$$

$N_{DSC}$ , may represent the number of data bearing subcarriers in an RF channel,  $N_B(CON)$  may represent the number of binary bits/symbol based on the modulation type, and R may represent the coding rate. For a 40 MHz RF channel,  $N_{DSC}$  may be approximately equal to 108. For a modulation type of 64 QAM, a symbol may comprise 6 binary bits. The total number of bits simultaneously transmitted via  $N_{SS}$  number of spatial streams may equal approximately  $N_{SS} * N_{DBPS}$ .

[0070] Data 306 comprising 1,500 binary octets may comprise a time duration of approximately 13 OFDM symbols and corresponding guard bands. In the PPDU preamble and header 402, legacy preamble, comprising the training fields L-STF 404, and L-LTF 406, and the signal field L-SIG 408, may comprise a time duration of approximately 5 OFDM symbols and corresponding guard bands. In the PPDU preamble and header 402, high throughput preamble and header, comprising the signal field HT-SIG 412, and training fields L-LTF 414 and L-LTF 416, may comprise a time duration of approximately 6 OFDM symbols and corresponding guard bands. The number of HT long training fields, N, may be equal to 2, for example.

[0071] A preamble and header 402, and data 306 comprising 1,500 binary octets, may produce a PPDU comprising a total time duration of approximately 24 OFDM symbols and corresponding guard bands in duration. Given a time duration of 4  $\mu$ s for each OFDM symbol and corresponding guard band, the total time duration may be approximately 96  $\mu$ s. Thus, the average data rate may be approximately equal to 1,500 binary octets, or 12,000 binary bits per 96  $\mu$ s, or approximately 125 Mbits/s. Approximately 54% of the total duration may consist of data 306. Approximately 21% of the total duration may comprise legacy preamble. Approximately 25% of the total duration may comprise high throughput preamble and header.

[0072] Elimination of the legacy preamble from the preamble and header 402 may enable an increase in data rate efficiency based on a data field 306 comprising 1,500 binary octets. In this case, the average data rate may be approximately 12,000 binary bits per 76  $\mu$ s, or approximately 158 Mbits/s, which is an increase of approximately 26% in the data rate.

[0073] If the modulation type were 64 QAM with the coding rate were decreased from  $\frac{3}{4}$  to  $\frac{2}{3}$ , each OFDM symbol may comprise 432 binary bits information. In this case, data comprising 1,500 binary octets may comprise a time duration of approximately 14 OFDM symbols and corresponding guard bands. Elimination of the legacy preamble from the preamble header 402 may produce an average data rate of approximately 12,000 binary bits per 80  $\mu$ s, or approximately 150 Mbits/s, which is an increase of approximately 20% in the data rate.

[0074] If the modulation type were 64 QAM with the coding rate were decreased from  $\frac{3}{4}$  to  $\frac{1}{2}$ , each OFDM

symbol may comprise 424 binary bits information. In this case, data comprising 1,500 binary octets may comprise a time duration of approximately 19 OFDM symbols and corresponding guard bands. Elimination of the legacy preamble from the preamble header 402 may produce an average data rate of approximately 12,000 binary bits per 100  $\mu$ s, or approximately 120 Mbits/s, which is a decrease of approximately 4% in data rate.

[0075] A consequence of the ability to achieve coding rate reduction while maintaining comparable or higher data rates as a result of the elimination of legacy preamble from a PPDU may enable those comparable data rates to be maintained at lower signal to noise ratios (SNR) than may be achievable when utilizing a PPDU preamble and header 402 that comprises legacy preamble. A coding rate reduction from  $\frac{3}{4}$  to  $\frac{2}{3}$  due to the elimination of legacy preamble resulting in greenfield access may correspond to at least 2 dB lower SNR for which a comparable, or higher, data rate may be maintained in comparison to a legacy preamble for mixed mode access PPDU with the preamble and header 402. This may be referred to as a greater than 2 dB performance gain for greenfield access relative to mixed mode access.

[0076] Utilization of LDPC coding to encode data 306 in a PPDU may produce a performance gain relative to the use of BCC coding. The performance gain realized from greenfield access may exceed that realized through the utilization of LDPC coding. Simulation results may show that LDPC provides a performance gain of 2 dB relative to BCC utilized as specified in IEEE 802.11a and in IEEE 802.11g. The utilization of LDPC may add some complexity to embodiments of the receiver 201.

[0077] FIG. 5a shows exemplary training fields and header fields for greenfield access in accordance with a WWiSE proposal for  $N_{SS}=2$ , in accordance with an embodiment of the invention. With reference to FIG. 5a, there is shown training fields and header for a first spatial stream 502, and training fields and header for a second spatial stream 512. The training fields and header 502 may comprise a high throughput (HT) short training field for the first spatial stream (HT-ST<sub>1</sub>) 504, a HT long training field for the first spatial stream (HT-LT<sub>1</sub>) 506, and a Signal-N field for the first spatial stream (Signal-N<sub>1</sub>) 508. The training fields and header 512 may comprise a HT short training field for the second spatial stream (HT-ST<sub>2</sub>) 514, a HT long training field for the second spatial stream (HT-LT<sub>2</sub>) 516, and a Signal-N field for the second spatial stream (Signal-N<sub>2</sub>) 518.

[0078] In operation, a short training field may be utilized by a receiver for a plurality of reasons including, but not limited to, signal detection, automatic gain control (AGC) for low noise amplification circuitry, diversity selection performed by, for example, rake receiver circuitry, coarse frequency offset estimation, and timing synchronization. A long training field may be utilized by a receiver for a plurality of reasons, for example, fine frequency offset estimation, and channel estimation. The training field HT-ST<sub>2</sub> 514 may comprise a time shifted representation of the training field HT-ST<sub>1</sub> 504. The training field HT-LT<sub>2</sub> 516 may comprise a time shifted representation of the training field HT-LT<sub>1</sub> 506. The signal field Signal-N<sub>2</sub> 518 may comprise a time shifted representation of the signal field Signal-N<sub>1</sub> 508. The training fields, HT-ST<sub>1</sub> 504 and HT-ST<sub>2</sub> 514, may comprise a time duration of about 8  $\mu$ s, and further

comprise a plurality of OFDM symbols, for example, a plurality of 10 OFDM symbols. The training fields, HT-LT<sub>1</sub> 506 and HT-LT<sub>2</sub> 516, may comprise a time duration of about 8  $\mu$ s, and further comprise a plurality of OFDM symbols, for example, a plurality of 2 OFDM symbols. The signal fields, Signal-N<sub>1</sub> 508 and Signal-N<sub>2</sub> 518, may comprise a time duration of about 4  $\mu$ s, and further comprise an OFDM symbol.

[0079] FIG. 5b shows an exemplary Signal-N header field for greenfield access in accordance with a WWiSE proposal, in accordance with an embodiment of the invention. With reference to FIG. 5b, there is shown a Signal-N header 552. The Signal-N header field may comprise a reserved field 554, a number of spatial streams ( $N_{SS}$ ) field 556, a number of transmit antennas (NTX) field 558, a BW field 560, a coding rate (R) field 562, an error correcting code type (CT) field 564, a constellation type (CON) field 566, a length field 568, a last PSDU indicator (LPI) field 570, a reserved field 572, a CRC field 574, and a tail field 576. The reserved field 554 may comprise 6 bits of binary information. The reserved field 572 may comprise 8 bits of binary information. The reserved fields 554 and 572 may have no assigned usage. The  $N_{SS}$  field 556 may comprise 3 bits of binary information. The  $N_{SS}$  field 556 may indicate the number of spatial streams utilized in transmitting information from a transmitter, for example, transmitter 200, and a receiver, for example receiver 201. In a MIMO system, the number of spatial streams may represent a number, for example, 1, 2, 3, or 4. The NTX field 558 may comprise 3 bits of binary information. The NTX field 558 may indicate the number of transmitting antenna utilized in transmitting information between a transmitter and a receiver. In a MIMO system, the number of transmitting antenna may represent a number, for example, 1, 2, 3, or 4. The BW field 560 may comprise 2 bits of binary information. The BW field 560 may represent a bandwidth, for example, 20 MHz, or 40 MHz.

[0080] The R field 562 may comprise 3 bits of binary information. The R field 628 may indicate the coding rate that is utilized for transmitting a physical layer service data unit (PSDU) that is transmitted via an antenna. In a MIMO system, the coding rate may represent a number, for example,  $\frac{1}{2}$ ,  $\frac{2}{3}$ ,  $\frac{3}{4}$ , or  $\frac{5}{6}$ . The CT field 564 may comprise 2 bits of binary information. The CT field 564 may indicate the error correcting code (ECC) type that is utilized in transmitting information via an antenna. In a MIMO system, the ECC type may represent an ECC method, for example, binary convolutional coding (BCC), or low density parity check coding (LDPC). The CON field 566 may comprise 3 bits of binary information. The CON field 566 may indicate the constellation type, or modulation type, which is utilized in transmitting a PSDU via an antenna. In a MIMO system, the modulation type may represent a constellation indicating the number of binary bits that may be encoded in a symbol, for example, binary phase shift keying (BPSK), quaternary phase shift keying (QPSK), 16 level quadrature amplitude modulation (16 QAM), 64 level QAM (64 QAM), or 256 level QAM (256 QAM).

[0081] The length field 568 may comprise 13 bits of binary information. The length field 568 may comprise information that indicates the number of binary octets of data payload information, for example, the physical layer service data unit (PSDU) 352. The LPI field 570 may comprise 1 bit of binary information. The LPI field 570 may

comprise information that indicates whether the corresponding PSDU 352 represents the last information comprised in a message. The CRC field 574 may comprise 4 bits of binary information. The CRC field 574 may comprise information that may be utilized by a receiver, for example, receiver 201, to detect the presence of errors in a received PPDU. The tail field 576 may comprise 6 bits of binary information. The tail field 576 may comprise information that is appended following the CRC field 574 to pad the Signal-N field to a desired length.

[0082] FIG. 5c shows exemplary training fields and header fields for greenfield access in accordance with a WWiSE proposal for  $N_{SS}=4$ , in accordance with an embodiment of the invention. With reference to FIG. 5c, there is shown training fields and a header field for a first spatial stream 503, training fields and a header field for a second spatial stream 513, training fields and a header field for a third spatial stream 522, and training fields and a header field for a fourth spatial stream 532.

[0083] The training fields and header field for the first spatial stream 503 may comprise a high throughput short training field HT-ST<sub>1</sub> 505, a first HT long training field (HT-LT<sub>1,1</sub>) 507, a Signal-N<sub>1</sub> field 508, and a second HT long training field (HT-LT<sub>1,2</sub>) 510. The training fields and header field for the second spatial stream 513 may comprise a high throughput short training field HT-ST<sub>2</sub> 515, a first HT long training field (HT-LT<sub>2,1</sub>) 517, a Signal-N<sub>2</sub> field 518, and a second HT long training field (HT-LT<sub>2,2</sub>) 520. The training fields and header field for the third spatial stream 522 may comprise a high throughput short training field HT-ST<sub>3</sub> 524, a first HT long training field (HT-LT<sub>3,1</sub>) 526, a Signal-N<sub>3</sub> field 528, and a second HT long training field (HT-LT<sub>3,2</sub>) 530. The training fields and header field for the fourth spatial stream 532 may comprise a high throughput short training field HT-ST<sub>4</sub> 534, a first HT long training field (HT-LT<sub>4,1</sub>) 536, a Signal-N<sub>4</sub> field 538, and a second HT long training field (HT-LT<sub>4,2</sub>) 540.

[0084] In operation, the training field HT-ST<sub>2</sub> 515 may comprise a time shifted representation of the training field HT-ST<sub>1</sub> 505. The training field HT-ST<sub>3</sub> 524 may comprise a time shifted representation of the training field HT-ST<sub>2</sub> 515. The training field HT-ST<sub>4</sub> 534 may comprise a time shifted representation of the training field HT-ST<sub>3</sub> 524. The training field HT-LT<sub>2,1</sub> 517 may comprise a time shifted representation of the training field HT-LT<sub>1,1</sub> 507. The training field HT-LT<sub>3,1</sub> 526 may comprise a time shifted representation of the training field HT-LT<sub>2,1</sub> 517. The training field HT-LT<sub>4,1</sub> 536 may comprise a time shifted representation of the training field HT-LT<sub>3,1</sub> 526. The signal field Signal-N<sub>2</sub> 518 may comprise a time shifted representation of the signal field Signal-N<sub>1</sub> 508. The signal field Signal-N<sub>3</sub> 528 may comprise a time shifted representation of the signal field Signal-N<sub>2</sub> 518. The signal field Signal-N<sub>4</sub> 538 may comprise a time shifted representation of the signal field Signal-N<sub>3</sub> 528. The training field HT-LT<sub>2,2</sub> 520 may comprise a time shifted representation of the training field HT-LT<sub>1,2</sub> 510. The training field HT-LT<sub>3,2</sub> 530 may comprise a time shifted representation of the training field HT-LT<sub>2,2</sub> 520. The training field HT-LT<sub>4,2</sub> 540 may comprise a time shifted representation of the training field HT-LT<sub>3,2</sub> 530.

[0085] The training fields, HT-ST<sub>1</sub> 505, HT-ST<sub>2</sub> 515, HT-ST<sub>3</sub> 524, and HT-ST<sub>4</sub> 534, may comprise a time duration of

about 8  $\mu$ s, and further comprise a plurality of OFDM symbols, for example, a plurality of 10 OFDM symbols. The training fields, HT-LT<sub>1,1</sub> 507, HT-LT<sub>1,2</sub> 510, HT-LT<sub>2,1</sub> 517, HT-LT<sub>2,2</sub> 520, HT-LT<sub>3,1</sub> 526, HT-LT<sub>3,2</sub> 530, HT-LT<sub>4,1</sub> 536, and HT-LT<sub>4,2</sub> 540, may comprise a time duration of about 8  $\mu$ s, and further comprise a plurality of OFDM symbols, for example, a plurality of 2 OFDM symbols. The signal fields, Signal-N<sub>1</sub> 508, Signal-N<sub>2</sub> 518, Signal-N<sub>3</sub> 528 and Signal-N<sub>4</sub> 538, may comprise a time duration of about 4  $\mu$ s, and further comprise an OFDM symbol.

[0086] Comparing FIG. 5a and FIG. 5c, the exemplary training fields and Signal-N header field illustrated in FIG. 5a, based on 2 spatial streams, 502 and 512, may each be of approximately 20  $\mu$ s in duration, or equivalent in time duration to 5 IEEE 802.11n OFDM symbols and corresponding guard bands. The exemplary training fields and Signal-N header field illustrated in FIG. 5c, based 4 spatial streams, 503, 513, 522, and 532, may each be of approximately 28  $\mu$ s in duration, or equivalent in time duration to 7 IEEE 802.11n OFDM symbols and corresponding guard bands.

[0087] FIG. 6a shows exemplary training fields and header fields with trailing signal field for greenfield access for  $N_{SS}>2$ , in accordance with an embodiment of the invention. With reference to FIG. 6a there is shown training fields and a header field for a first spatial stream 602, training fields and a header field for a second spatial stream 622, and training fields and a header field for spatial stream  $N_{SS}$  642. The training fields and header field for the first spatial stream 602 may comprise a short training field HT-STF<sub>1</sub> field 604, a long training field HT-LTF<sub>1,1</sub> field 606, a plurality of subsequent long training fields HT-LTF<sub>1,2} . . . HT-LTF<sub>1,N</sub> 608 . . . 610, and a Signal\*-N<sub>1</sub> field 612. The training sequence and header field for the second spatial stream 622 may comprise an HT-STF<sub>2</sub> field 624, an HT-LTF<sub>2,1</sub> field 626, a plurality of HT-LTF<sub>2,2} . . . HT-LTF<sub>2,N</sub> fields 628 . . . 630, and a Signal\*-N<sub>2</sub> field 632. The training sequence and header field for spatial stream  $N_{SS}$  642 may comprise an HT-STF field 644, an HT-LTF <sub>$N_{SS},1$</sub>  field 646, a plurality of HT-LTF <sub>$N_{SS},2} . . . HT-LTF <sub>$N_{SS},N$</sub>$</sub>  fields 648 . . . 650, and a Signal\*-N <sub>$N_{SS}$</sub>  field 652. The Signal\*-N fields 612, 632, and 652 may be represented as shown in FIG. 4c.</sub></sub>

[0088] In operation, the short training sequence utilized in the training field HT-STF<sub>1</sub> 604, STS<sub>1</sub>, may be represented as a vector comprising a plurality of coefficients. The short training sequence utilized in the training field HT-STF<sub>2</sub> 624, STS<sub>2</sub>, may be represented as a vector comprising a plurality of coefficients. The short training sequence utilized in the training field HT-STF <sub>$N_{SS}$</sub>  644, STS <sub>$N_{SS}$</sub> , may be represented as a vector comprising a plurality of coefficients. Each vector representation among the plurality of vector representations STS<sub>1} . . . STS <sub>$N_{SS}$</sub>  may be orthonormal to each of the other vector representations in the plurality of vector representations.</sub>

[0089] The long training sequence utilized in the first training field of the first spatial stream, HT-LTF<sub>1,1</sub> 606, LTS<sub>1,1</sub>, may be represented as a vector comprising a plurality of coefficients. The long training sequence utilized in the first training field of the second spatial stream HT-LTF<sub>2,1</sub> 626, LTS<sub>2,1</sub>, may be represented as a vector comprising a plurality of coefficients. The long training sequence utilized in the first training field of spatial stream  $N_{SS}$  HT-LTF <sub>$N_{SS},1$</sub>

**646**,  $LTS_{N_{SS},1}$ , may be represented as a vector comprising a plurality of coefficients. Each vector representation among the plurality of vector representations  $LTS_{1,1} \dots LTS_{N_{SS},1}$  may be orthonormal to each of the other vector representations in the plurality of vector representations.

[0090] The long training sequence utilized in the second training field of the first spatial stream HT-LTF<sub>1,2</sub> **608**,  $LTS_{1,2}$ , may be represented as a vector comprising a plurality of coefficients. The long training sequence utilized in the second training field of the second spatial stream HT-LTF<sub>2,2</sub> **628**,  $LTS_{2,2}$ , may be represented as a vector comprising a plurality of coefficients. The long training sequence utilized in the second training field of spatial stream  $N_{SS}$  HT-LTF<sub>N<sub>SS</sub>,2</sub> **648**,  $LTS_{N_{SS},2}$ , may be represented as a vector comprising a plurality of coefficients. Each vector representation among the plurality of vector representations  $LTS_{1,2} \dots LTS_{N_{SS},2}$  may be orthonormal to each of the other vector representations in the plurality of vector representations.

[0091] The long training sequence utilized in the training field N of the first spatial stream HT-LTF<sub>1,N</sub> **610**,  $LTS_{1,N}$ , may be represented as a vector comprising a plurality of coefficients. The long training sequence utilized in the training field N of the second spatial stream HT-LTF<sub>2,N</sub> **630**,  $LTS_{2,N}$ , may be represented as a vector comprising a plurality of coefficients. The long training sequence utilized in the training field N of spatial stream  $N_{SS}$  HT-LTF<sub>N<sub>SS</sub>,N</sub> **650**,  $LTS_{N_{SS},N}$ , may be represented as a vector comprising a plurality of coefficients. Each vector representation among the plurality of vector representations  $LTS_{1,N} \dots LTS_{N_{SS},N}$  may be orthonormal to each of the other vector representations in the plurality of vector representations. The number of long training fields, N, may be approximately equal to the number of spatial streams,  $N_{SS}$ .

[0092] Orthonormality is a property of vectors such that for any two vectors, X and Y, the vector dot product of the vectors may equal zero. When applied to long training sequences, the property of orthonormality may result in the generation of long training sequences whose vector representations exhibit the property of orthonormality. The generation of an orthonormal long training sequence may produce phase shifts among the frequency subcarriers that comprise an OFDM symbol generated based on the long training sequence. The phase shifts may improve the quality of transmitted OFDM symbols by reducing the likelihood of accidental nulls in the beam pattern of the signals transmitted by a transmitter **200** (FIG. 2b). The utilization of known phase shifts among the frequency subcarriers may enable a receiver **201** to remove the phase shifts in a received signal during channel estimation. The placement of the Signal\*-N fields **612**, **632**, and **652** following the corresponding pluralities of long training sequence fields in each of the spatial streams may enable a receiver to utilize a full channel estimate, based on the preceding long training fields for each spatial stream, for example, long training sequence fields **606** and **608** . . . **610** in the first spatial stream, in detecting the corresponding Signal\*-N field.

[0093] In MIMO systems, orthonormal sequences may enable a receiver **201** (FIG. 1) to more easily distinguish a signal transmitted from a specific transmitter antenna front end **214a** . . . **214n** at a transmitter **200**. A matched filter at receiver antenna front ends **216a** . . . **216n** at the receiver **201** may enable the receiver to receive a signal transmitted by a

specific transmitter antenna front end **214a** . . . **214n** at a specific receiver antenna front end **216a** . . . **216n**.

[0094] The training fields, HT-STF<sub>1</sub> **604**, HT-STF<sub>2</sub> **624**, and HT-STF<sub>N<sub>SS</sub></sub> **644**, may comprise a time duration of about 8 μs, and further comprise a plurality of OFDM symbols, for example, a plurality of 10 OFDM symbols. The training fields, HT-LTF<sub>1,1</sub> **606**, HT-LTF<sub>2,1</sub> **626**, and HT-LTF<sub>N<sub>SS</sub>,1</sub> **646**, may comprise a time duration of about 8 μs, and further comprise a plurality of OFDM symbols, for example, a plurality of 2 OFDM symbols. The plurality of OFDM symbols in training field **606** may be identical. The plurality of OFDM symbols in training field **646** may be identical. The pluralities of training fields, HT-LTF<sub>1,2} \dots HT-LTF\_{1,N} \b608 \dots \b610, HT-LTF\_{2,2} \dots HT-LTF\_{2,N} \b628 \dots \b630, and HT-LTF\_{N\_{SS},2} \dots HT-LTF\_{N\_{SS},N} \b648 \dots \b650, may comprise a time duration of about 4 μs, and further comprise an OFDM symbol. Utilizing orthonormal training sequences after the first long training sequence may obviate tone interleaving, which may be a desirable feature because the first long training sequence may utilize identical symbols. The signal fields, Signal\*-N **612**, Signal\*-N<sub>2</sub> **632**, and Signal\*-N<sub>N<sub>SS</sub></sub> **652**, may comprise a time duration of about 8 μs, and further comprise a plurality of OFDM symbols, for example, a plurality of 2 OFDM symbols.</sub>

[0095] For  $N_{SS}=2$  there may be a plurality of  $N=2$  long training fields in exemplary training fields and header field **602**, **622**, or **642**. Referring to FIG. 6a for the case of 2 transmitted spatial streams, the training fields and Signal\*-N header field **602**, **622**, and **642** may comprise a time duration of about 28 μs, and further comprise a plurality of 7 IEEE 802.11n OFDM symbols. For the case of 3 transmitted spatial streams, the training fields and header field **602**, **622**, and **642** may comprise a time duration of about 32 μs, and further comprise a plurality of 8 IEEE 802.11n OFDM symbols. For the case of 4 transmitted spatial streams, the training fields and header field **602**, **622**, and **642** may comprise a time duration of about 36 μs, and further comprise a plurality of 9 IEEE 802.11n OFDM symbols.

[0096] Comparing the training fields and header field **402**, **422**, or **442** (FIG. 4a) for mixed mode access in an IEEE 802.11n WLAN to comparable training fields and header field **602**, **622**, or **642** (FIG. 6a) for greenfield access in an IEEE 802.11n WLAN for the case of 2 transmitted spatial streams may indicate that the training fields and header field **602**, **622**, or **642** may comprise a time duration that is approximately 16 μs shorter in duration than that of comparable training fields and header field **402**, **422**, or **442**. This may correspond to a reduction of 4 fewer IEEE 802.11n OFDM symbols transmitted with each physical layer protocol data unit (PPDU).

[0097] In various embodiments of the invention, as illustrated in the exemplary training fields and header field in FIG. 6a, the Signal\*-N field be represented as described in FIG. 4c. The Signal\*-N field may comprise a time duration of approximately 8 μs, and further comprise 2 OFDM symbols. Each of the first high throughput long training fields among the spatial streams, HT-LTF<sub>1,1</sub> **606**, HT-LTF<sub>2,1</sub> **626**, and HT-LTF<sub>N<sub>SS</sub>,1</sub> **646** may comprise a time duration of approximately 8 μs, and further comprise 2 OFDM symbols. Each of the first high throughput long training fields among the spatial streams, HT-LTF<sub>1,1</sub> **606**, HT-LTF<sub>2,1</sub> **626**, and

HT-LTF<sub>N<sub>SS</sub>,1</sub> **646** may comprise identical OFDM symbols that may be utilized for fine frequency offset estimation as may be specified in IEEE resolutions 802.11a, and 802.11g.

[0098] **FIG. 6b** shows exemplary training fields and header fields with early signal field for greenfield access for N<sub>SS</sub>>2, in accordance with an embodiment of the invention. **FIG. 6b** differs from **FIG. 6a** in that, in **FIG. 6b**, a signal field may follow a first long training field in a spatial stream PDU, with one or more subsequent long training fields following the signal field. With reference to **FIG. 6b** there is shown training fields and a header field for a first spatial stream **602a**, training fields and a header field for a second spatial stream **622a**, and training fields and a header field for spatial stream N<sub>SS</sub> **642a**. The training fields and header field for the first spatial stream **602a** may comprise a short training field HT-STF<sub>1</sub> field **604a**, a long training field HT-LTF<sub>1,1</sub> field **606a**, a plurality of subsequent long training fields HT-LTF<sub>1,2</sub> . . . HT-LTF<sub>1,N</sub> **608a** . . . **610a**, and a Signal\*-N<sub>1</sub> field **612a**. The training sequence and header field for the second spatial stream **622a** may comprise an HT-STF<sub>2</sub> field **624a**, an HT-LTF<sub>2,1</sub> field **626a**, a plurality of HT-LTF<sub>2,2</sub> . . . HT-LTF<sub>2,N</sub> fields **628a** . . . **630a**, and a Signal\*-N<sub>2</sub> field **632a**. The training sequence and header field for spatial stream N<sub>SS</sub> **642a** may comprise an HT-STF<sub>N<sub>SS</sub></sub> field **644a**, an HT-LTF<sub>N<sub>SS</sub>,1</sub> field **646a**, a plurality of HT-LTF<sub>N<sub>SS</sub>,2</sub> . . . HT-LTF<sub>N<sub>SS</sub>,N</sub> fields **648a** . . . **650a**, and a Signal\*-N<sub>N<sub>SS</sub></sub> field **652a**.

[0099] Long training sequences may be utilized for generating OFDM symbols that may be transmitted during long training fields. Long training sequences for N<sub>SS</sub>=2 may be defined as follows:

$$HT - LTF = \begin{bmatrix} & .11aLT & .11aLT \\ [i, j] & [-.11aLT * e^{j*theta(k)} & .11aLT * e^{j*theta(k)} \end{bmatrix} \quad \text{equation [7]}$$

where the index, i, may represent a row in the matrix, and the index, j, may represent a column. Each row may represent a corresponding spatial stream, with each column representing a corresponding long training sequence. .11aLT indicates that the training sequence may be based on specifications in IEEE 802.11a, theta(k) may indicate a phase shift in the LT field for OFDM subcarrier k in an RF channel where the phase shift may vary as a function of the index k.

$$HT - LTF [i, j] = \begin{bmatrix} .11aLT * W11 & .11aLT * W12 & .11aLT * W13 \\ .11aLT * W21 * e^{j*theta(k)} & .11aLT * W22 * e^{j*theta(k)} & .11aLT * W22 * e^{j*theta(k)} \\ .11aLT * W31 * e^{j*phi(k)} & .11aLT * W32 * e^{j*phi(k)} & .11aLT * W33 * e^{j*phi(k)} \end{bmatrix} \quad \text{equation [11]}$$

[0100] Individual elements in the long training sequence, .11aLT, based on IEEE 802.11a for a 20 MHz channel, may be represented utilizing the vector notation, LS[k], where k may comprise a range of integer values from and including -N<sub>SC</sub>/2, up to and including N<sub>SC</sub>/2, as:

$$.11aLT = \begin{bmatrix} 1, 1, 1, 1, -1, -1, 1, 1, -1, 1, 1, 1, 1, 1, \\ 1, 1, 1, -1, -1, 1, 1, -1, 1, -1, 1, \\ 1, 1, 1, 0, 1, -1, -1, 1, 1, -1, 1, \\ -1, 1, -1, -1, -1, -1, -1, 1, 1, -1, \\ -1, 1, -1, 1, -1, 1, 1, 1, -1, -1 \end{bmatrix} \quad \text{equation [8]}$$

where the first element in equation[8] may represent LS[-N<sub>SC</sub>/2] and the last element may represent LS[N<sub>SC</sub>/2].

[0101] A long OFDM training symbol, r<sub>LONG</sub>(t), where the variable t may represent time, may be generated according to the equation:

$$r_{LONG}(t) = w_{TLONG}(t) \sum_{k=N_{SC}/2}^{N_{SC}/2} LS[k] e^{j2\pi\Delta_f(t-T_{G12})} \quad \text{equation [9]}$$

where N<sub>SC</sub> may represent the number of frequency subcarriers, Δ<sub>f</sub> may represent the frequency spacing between subcarriers, T<sub>G12</sub> may represent the training symbol guard band time interval, and w<sub>TLONG</sub>(t) may represent the timing window for the long training sequence. The timing window w<sub>TLONG</sub>(t) may be represented as:

$$w_T(nT_s) = \begin{cases} 1 & 1 \leq n \leq 79 \\ 0.5 & 0, 80 \\ 0 & \text{otherwise} \end{cases}, \quad \text{where} \quad \text{equation [10]}$$

the sampling interval, T<sub>s</sub>, may equal approximately 50 ns for a 20 MHz channel, and n may represent a sample of the OFDM signal as represented by equation[9] taken at a time t=nT<sub>s</sub> during a timing window interval for transmission of an OFDM symbol.

[0102] With reference to equation[9] for N<sub>SS</sub>=2, substitution of a long training sequence element HT-LTF[i,j] from equation[7] for LS[k] in equation[9] may be utilized to generate an OFDM symbol for the j<sup>th</sup> long training field in the i<sup>th</sup> spatial stream. In the first long training field, the OFDM symbol generated by equation[9] may be transmitted twice.

[0103] The LT fields may be defined for N<sub>SS</sub>=3 as follows:

where the index, i, may represent a row in the matrix, and the index, j, may represent a column. Each row may represent a corresponding spatial stream, with each column representing a corresponding long training sequence. W<sub>mn</sub> may represent elements from a discrete Fourier transform

(DFT) matrix, and  $\phi(k)$  indicates a phase shift in the LT field for OFDM subcarrier  $k$  where the phase shift varies as a function of  $k$  where  $\phi(k)$  may not equal  $\theta(k)$ .

[0104] The DFT matrix,  $W_{mn}$ , may be represented as:

$$W_{mn} = \begin{bmatrix} 1 & 1 & 1 \\ 1 & \frac{-1 - i\sqrt{3}}{2} & \frac{-1 + i\sqrt{3}}{2} \\ 1 & \frac{-1 + i\sqrt{3}}{2} & \frac{-1 - i\sqrt{3}}{2} \end{bmatrix}, \text{ where} \quad \text{equation [12]}$$

the index,  $m$ , may represent a row in the matrix, and the index,  $n$ , may indicate a column.

[0105] With reference to equation[9] for  $N_{SS}=3$ , substitution of a long training sequence element HT-LTF $[i,j]$  from equation[11] for LS $[k]$  in equation[9] may be utilized to generate an OFDM symbol for the  $j^{\text{th}}$  long training field in the  $i^{\text{th}}$  spatial stream. In the first long training field, the OFDM symbol generated by equation[9] may be transmitted twice.

[0106] The LT fields may be defined for  $N=4$  as follows:

$$HT-LTF \begin{bmatrix} [i, j] \end{bmatrix} = \begin{bmatrix} -1 * .11aLT & .11aLT & .11aLT & .11aLT \\ .11aLT * e^{j\theta(k)} & -1 * .11aLT * e^{j\theta(k)} & .11aLT * e^{j\theta(k)} & .11aLT * e^{j\theta(k)} \\ .11aLT * e^{j\phi(k)} & .11aLT * e^{j\phi(k)} & -1 * .11aLT * e^{j\phi(k)} & .11aLT * e^{j\phi(k)} \\ .11aLT * e^{j\psi(k)} & .11aLT * e^{j\psi(k)} & .11aLT * e^{j\psi(k)} & -1 * .11aLT * e^{j\psi(k)} \end{bmatrix} \quad \text{equation [13]}$$

where the index,  $i$ , may represent a row in the matrix, and the index,  $j$ , may represent a column. Each row may represent a corresponding spatial stream, with each column representing a corresponding long training sequence.  $\phi(k)$  indicates a phase shift in the LT field for OFDM subcarrier  $k$  where the phase shift varies as a function of  $k$ .  $\psi(k)$  indicates a phase shift in the LT field for OFDM subcarrier  $k$  where the phase shift varies as a function of  $k$ . The phase shifts  $\phi(k)$ ,  $\theta(k)$ , and  $\psi(k)$  may not be equal.

[0107] With reference to equation[9] for  $N_{SS}=4$ , substitution of a long training sequence element HT-LTF $[i,j]$  from equation[13] for LS $[k]$  in equation[9] may be utilized to generate an OFDM symbol for the  $j^{\text{th}}$  long training field in the  $i^{\text{th}}$  spatial stream. In the first long training field, the OFDM symbol generated by equation[9] may be transmitted twice.

[0108] The long training sequence as represented in equation[8] may be utilized to generate a plurality of orthonormal long training sequences. Alternatively, orthonormal long training sequence fields may be generated. If the long training sequences in different long training sequence fields are orthonormal, the corresponding long training sequence fields may also be orthonormal. Orthonormal long training sequences or long training sequence fields may be generated by a plurality of methods. In one embodiment of the invention, orthonormal long training sequence fields may be generated by utilizing a discrete Fourier transform matrix to apply phase shifts to individual long training sequence fields among a plurality of long training sequence fields in a spatial

stream. The utilization of a discrete Fourier transform matrix may enable the orthonormal generator sequence to be of minimum length. The property of orthonormality may be observed in that a long training sequence field in a current spatial stream may be orthogonal to a corresponding long training sequence field in a subsequent spatial stream. A plurality of orthogonal long training sequences fields, HT-LTF $_n[i,j]$ , for a plurality of spatial streams may be generated according to the following relationship:

$$HT-LTF_n[i,j] = HT-LTF[i,j] e^{-j2\pi ij/N_{SS}}, \text{ where} \quad \text{equation[14]}$$

the index  $i$  may refer to an individual spatial stream among a plurality of spatial streams, the index  $j$  may refer to an individual long training sequence field within a spatial stream,  $N_{SS}$  may refer to the number of transmitted spatial streams, and HT-LTF $[i,j]$  may refer to an individual long training sequence field as represented in any of equations[7], [11], or [13]. As an example of the property of orthonormality, a  $j^{\text{th}}$  high throughput long training sequence field for a first spatial stream HT-LTF $_n[1,j]$  may be orthonormal to a corresponding  $j^{\text{th}}$  high throughput long training sequence field for a second spatial stream HT-LTF $_n[2,j]$ .

[0109] In another embodiment of the invention, a discrete Hadamard transform may be utilized to generate orthonor-

mal long training sequences based on a Hadamard matrix. A property of a Hadamard matrix is that the matrix may comprise values of +1 and -1 such that the rows of the Hadamard matrix may be mutually orthogonal. For example, a long training sequence,  $O(.11aLT)$ , that may be orthonormal to the long training sequence  $.11aLT$  as expressed in equation[8] is:

$$.11aLT = \begin{bmatrix} 1, -1, 1, -1, -1, 1, 1, -1, -1, -1, \\ -1, -1, 1, -1, 1, -1, 1, 1, -1, -1, 1, \\ 1, 1, 1, 1, -1, 1, -1, 0, 1, 1, -1, -1, \\ 1, 1, 1, 1, 1, 1, -1, 1, -1, 1, 1, -1, \\ -1, 1, 1, 1, 1, 1, 1, -1, 1, -1, -1, 1 \end{bmatrix} \quad \text{equation [15]}$$

[0110] Various embodiments of the invention may not be limited in the methods that may be utilized in generating orthonormal long training sequences or orthonormal long training sequence fields.

[0111] FIG. 7 shows exemplary training fields and header fields for mixed mode access for  $N_{SS}>2$ , in accordance with an embodiment of the invention. With reference to FIG. 7 there is shown a plurality of PPDU preambles and headers 702, 722, and 742. The preamble and header 702 may comprise a legacy short training field (L-STF) 404, a legacy long training field (L-LTF) 406, a legacy signal field (L-SIG)

**408**, a high throughput signal field (HT-SIG) **410**, a high throughput short training field for the first spatial stream (HT-STF<sub>1</sub>) **712**, and a plurality of high throughput long training fields for the first spatial stream comprising training fields number **1** through **N** (HT-LTF<sub>1,1</sub> . . . HT-LTF<sub>1,N</sub>) **714** . . . **716**. The integer value **N** may represent the number of long training fields contained in the preamble and header **702**.

[**0112**] The preamble and header **722** may comprise a legacy short training field (L-STF) **424**, a legacy long training field (L-LTF) **426**, a legacy signal field (L-SIG) **428**, a high throughput signal field (HT-SIG) **430**, a high throughput short training field for the second spatial stream (HT-STF<sub>2</sub>) **732**, and a plurality of high throughput long training fields for the second spatial stream comprising training fields number **1** through **N** (HT-LTF<sub>2,1</sub> . . . HT-LTF<sub>2,N</sub>) **734** . . . **736**. The integer value **N** may represent the number of long training fields contained in the preamble and header **722**.

[**0113**] The preamble and header **742** may comprise a legacy short training field (L-STF) **444**, a legacy long training field (L-LTF) **446**, a legacy signal field (L-SIG) **448**, a high throughput signal field (HT-SIG) **450**, a high throughput short training field for the spatial stream  $N_{SS}$  (HT-STF<sub>NSS</sub>) **752**, and a plurality of high throughput long training fields for the spatial stream  $N_{SS}$  comprising training fields number **1** through **N** (HT-LTF<sub>NSS,1</sub> . . . HT-LTF<sub>NSS,N</sub>) **754** . . . **756**. The integer value **N** may represent the number of long training fields contained in the preamble and header **702**.

[**0114**] The HT-STF fields **712**, **732**, and **752** may each comprise a time duration of about 3.2  $\mu$ s, and the HT-LTF fields **714** . . . **716**, **734** . . . **736**, and **754** . . . **756** may each comprise a time duration of about 4  $\mu$ s. The time duration of about 3.2  $\mu$ s for the HT-STF fields **712**, **732**, and **752** may represent an increase of about 800 ns in time duration relative to the corresponding time duration of about 2.4  $\mu$ s for the HT-STF fields **412**, **432**, and **452**. The increase of about 800 ns in time duration may allow more time for automatic gain control settling in adapting transmission of signals to utilize beamforming.

[**0115**] Comparing the training fields and header fields **702**, **722**, and **742** to the comparable the training fields and header fields **402**, **422**, and **442** for the case of 2 transmitted spatial streams, wherein  $N=2$ , may indicate that the training fields and header fields **702**, **722**, and **742** may comprise a time duration about 5.6  $\mu$ s shorter than for the comparable training fields and header fields **402**, **422**, and **442**. Comparing the training fields and header fields **702**, **722**, and **742** to the comparable the training fields and header fields **402**, **422**, and **442** for the case of 3 transmitted spatial streams, wherein  $N=3$ , may indicate that the training fields and header fields **702**, **722**, and **742** may comprise a time duration of about 8.8  $\mu$ s shorter than for the comparable training fields and header fields **402**, **422**, and **442**. Comparing the training fields and header fields **702**, **722**, and **742** to the comparable the training fields and header fields **402**, **422**, and **442** for the case of 4 transmitted spatial streams, wherein  $N=2$ , may indicate that the training fields and header fields **702**, **722**, and **742** may comprise a time duration about 12  $\mu$ s shorter than for the comparable training fields and header fields **402**, **422**, and **442**.

[**0116**] Various embodiments of the invention may provide a system for communicating information in a multiple input

multiple output (MIMO) communications system that may comprise a transmitter **200** (**FIG. 2b**) that generates a protocol data unit (PDU) for a current spatial stream comprising a current plurality of long training sequence fields. The transmitter **200** may generate a PDU for a subsequent spatial stream comprising a subsequent plurality of long training sequence fields wherein one of the subsequent plurality of long training sequence fields is orthonormal to a corresponding one of the current plurality of long training sequence fields. The transmitter **200** may append a signal field subsequent to the last of the plurality of long training sequence fields.

[**0117**] Various embodiments of the invention may provide a system for communicating information in a multiple input multiple output (MIMO) communications system that may comprise a transmitter that constructs a greenfield protocol data unit (PDU) comprising a high throughput short training sequence field comprising a time duration of approximately 8  $\mu$ s. The transmitter may append a first long training sequence field, comprising a time duration of approximately 8  $\mu$ s, subsequent to the high throughput short training sequence field. The transmitter may also append at least one subsequent long training sequence field, comprising a time duration of approximately 4  $\mu$ s, subsequent to the first long training sequence field. In addition, the transmitter may append a signal field, comprising a time duration of approximately 8  $\mu$ s, subsequent to the last of at least one subsequent long training sequence field.

[**0118**] Aspects of a method for communicating information in a multiple input multiple output (MIMO) communications system that may comprise constructing a greenfield protocol data unit (PDU) comprising a high throughput short training sequence field comprising a time duration of approximately 8  $\mu$ s. The method may further comprise appending a first long training sequence field, comprising a time duration of approximately 8  $\mu$ s, subsequent to the high throughput short training sequence field. At least one subsequent long training sequence field, comprising a time duration of approximately 4  $\mu$ s, may be appended subsequent to the first long training sequence field. A signal field, comprising a time duration of approximately 8  $\mu$ s, may also be appended subsequent to the last of at least one subsequent long training sequence field.

[**0119**] Aspects of a method for communicating information in a multiple input multiple output (MIMO) communications system may comprise constructing a mixed mode protocol data unit (PDU) comprising a legacy short training sequence field comprising a time duration of approximately 8  $\mu$ s. A legacy long training sequence field comprising a time duration of approximately 8  $\mu$ s may be appended. A legacy signal field comprising a time duration of approximately 4  $\mu$ s may be appended. The method may comprise appending a high throughput signal field, comprising a time duration of approximately 8  $\mu$ s, subsequent to the legacy signal field. The method may further comprise appending a high throughput short training sequence field comprising a time duration of approximately 3.2  $\mu$ s, subsequent to the high throughput signal field, and subsequently appending a plurality of long training sequence fields, comprising a time duration of approximately 4  $\mu$ s.

[**0120**] Accordingly, the present invention may be realized in hardware, software, or a combination of hardware and

software. The present invention may be realized in a centralized fashion in at least one computer system, or in a distributed fashion where different elements are spread across several interconnected computer systems. Any kind of computer system or other apparatus adapted for carrying out the methods described herein is suited. A typical combination of hardware and software may be a general-purpose computer system with a computer program that, when being loaded and executed, controls the computer system such that it carries out the methods described herein.

[0121] The present invention may also be embedded in a computer program product, which comprises all the features enabling the implementation of the methods described herein, and which when loaded in a computer system is able to carry out these methods. Computer program in the present context means any expression, in any language, code or notation, of a set of instructions intended to cause a system having an information processing capability to perform a particular function either directly or after either or both of the following: a) conversion to another language, code or notation; b) reproduction in a different material form.

[0122] While the present invention has been described with reference to certain embodiments, it will be understood by those skilled in the art that various changes may be made and equivalents may be substituted without departing from the scope of the present invention. In addition, many modifications may be made to adapt a particular situation or material to the teachings of the present invention without departing from its scope. Therefore, it is intended that the present invention not be limited to the particular embodiment disclosed, but that the present invention will include all embodiments falling within the scope of the appended claims.

What is claimed is:

1. A method for communicating information in a multiple input multiple output (MIMO) communications systems, the method comprising:

generating a protocol data unit (PDU) for a current spatial stream comprising a current plurality of long training sequence fields;

appending a signal field subsequent to a last of said current plurality of long training sequence fields;

generating a PDU for a subsequent spatial stream comprising a subsequent plurality of long training sequence fields wherein one of said subsequent plurality of long training sequence fields is orthonormal to a corresponding one of said current plurality of long training sequence fields; and

appending a subsequent signal field subsequent to a last of said subsequent plurality of long training sequence fields.

2. The method according to claim 1, further comprising transmitting 2 orthogonal frequency division multiplexing (OFDM) symbols during a first long training sequence field of said current plurality of long training sequence fields.

3. The method according to claim 2, further comprising generating said 2 OFDM symbols based on long training sequences that are approximately identical.

4. The method according to claim 2, further comprising transmitting 1 OFDM symbol during a long training sequence field that is subsequent to said first long training sequence field.

5. The method according to claim 1, further comprising transmitting 2 OFDM symbols during said signal field.

6. The method according to claim 1, further comprising, for a first spatial stream, transmitting a first long training sequence field, and a second long training field via said current spatial stream, in a system utilizing 2 transmitted spatial streams, wherein said first long training sequence field, and said second long training sequence field utilizes a long training sequence based on IEEE 802.11a.

7. The method according to claim 1, further comprising, for a second spatial stream, transmitting a first long training sequence field, and a second long training field via said current spatial stream, in a system utilizing 2 transmitted spatial streams, wherein said first long training sequence field, and said second long training sequence field utilizes a phase shifted long training sequence based on IEEE 802.11a.

8. The method according to claim 1, further comprising, for a first spatial stream, transmitting a first long training sequence field, a second long training sequence field, and a third long training field via said current spatial stream, in a system utilizing 3 transmitted spatial streams, wherein said first long training sequence field, said second long training sequence field, and said third long training sequence field utilizes a multiplicatively scaled long training sequence based on IEEE 802.11a.

9. The method according to claim 8, further comprising transmitting a first long training sequence field, a second long training sequence field, and a third long training field via a subsequent to said first spatial stream, in a system utilizing 3 transmitted spatial streams, wherein said first long training sequence field, said second long training sequence field, and said third long training sequence field utilizes a multiplicatively scaled and phase shifted long training sequence based on IEEE 802.11a.

10. The method according to claim 1, further comprising, for a first spatial stream, transmitting a first long training sequence field via said current spatial stream, in a system utilizing 4 transmitted spatial streams, wherein said first long training sequence field utilizes a multiplicatively scaled long training sequence based on IEEE 802.11a.

11. The method according to claim 10, further comprising transmitting a subsequent to said first long training sequence field, via said first spatial stream, wherein said subsequent long training sequence field utilizes a long training sequence based on IEEE 802.11a.

12. The method according to claim 11, wherein a subsequent to said first spatial stream comprises a corresponding long training sequence to said first long training sequence field that utilizes said multiplicatively scaled long training sequence, and a plurality of long training sequence fields that utilize said long training sequence based on IEEE 802.11a.

13. The method according to claim 1, further comprising generating said corresponding one of said current plurality based on a discrete Fourier transform matrix.

14. A system for communicating information in a multiple input multiple output (MIMO) communications systems, the system comprising:

a transmitter that generates a protocol data unit (PDU) for a current spatial stream comprising a current plurality of long training sequence fields;

said transmitter appends a signal field subsequent to a last of said current plurality of long training sequence fields;

said transmitter generates a PDU for a subsequent spatial stream comprising a subsequent plurality of long training sequence fields wherein one of said subsequent plurality of long training sequence fields is orthonormal to a corresponding one of said current plurality of long training sequence fields; and

said transmitter appends a subsequent signal field subsequent to a last of said subsequent plurality of long training sequence fields.

**15.** The system according to claim 14, further comprising antenna front end circuitry that transmits 2 orthogonal frequency division multiplexing (OFDM) symbols during a first long training sequence field of said current plurality of long training sequence fields.

**16.** The system according to claim 15, further comprising inverse fast Fourier transform circuitry that generates said 2 OFDM symbols based on long training sequences that are approximately identical.

**17.** The system according to claim 15, wherein said antenna front end circuitry transmits 1 OFDM symbol during a long training sequence field that is subsequent to said first long training sequence field.

**18.** The system according to claim 14, further comprising antenna front end circuitry that transmits 2 OFDM symbols during said signal field.

**19.** The system according to claim 14, further comprising, for a first spatial stream, antenna front end circuitry that transmits a first long training sequence field, and a second long training field via said current spatial stream, in a system utilizing 2 transmitted spatial streams, wherein said first long training sequence field, and said second long training sequence field utilizes a long training sequence based on IEEE 802.11a.

**20.** The system according to claim 14, further comprising, for a second spatial stream, antenna front end circuitry that transmits a first long training sequence field, and a second long training field via said current spatial stream, in a system utilizing 2 transmitted spatial streams, wherein said first long training sequence field, and said second long training sequence field utilizes a phase shifted long training sequence based on IEEE 802.11a.

**21.** The system according to claim 14, further comprising, for a first spatial stream, antenna front end circuitry that transmits a first long training sequence field, a second long training sequence field, and a third long training field via said current spatial stream, in a system utilizing 3 transmitted spatial streams, wherein said first long training sequence field, said second long training sequence field, and said third long training sequence field utilizes a multiplicatively scaled long training sequence based on IEEE 802.11a.

**22.** The system according to claim 21, wherein said antenna front end circuitry transmits a first long training

sequence field, a second long training sequence field, and a third long training field via a subsequent to said first spatial stream, in a system utilizing 3 transmitted spatial streams, wherein said first long training sequence field, said second long training sequence field, and said third long training sequence field utilizes a multiplicatively scaled and phase shifted long training sequence based on IEEE 802.11a.

**23.** The system according to claim 14, further comprising, for a first spatial stream, antenna front end circuitry that transmits a first long training sequence field via said current spatial stream, in a system utilizing 4 transmitted spatial streams, wherein said first long training sequence field utilizes a multiplicatively scaled long training sequence based on IEEE 802.11a.

**24.** The system according to claim 23, wherein said antenna front end circuitry transmits a subsequent to said first long training sequence field, via said first spatial stream, wherein said subsequent long training sequence field utilizes a long training sequence based on IEEE 802.11a.

**25.** The system according to claim 24, wherein a subsequent to said first spatial stream comprises a corresponding long training sequence to said first long training sequence field that utilizes said multiplicatively scaled long training sequence, and a plurality of long training sequence fields that utilize said long training sequence based on IEEE 802.11a.

**26.** The system according to claim 14, wherein said transmitter generates said corresponding one of said current plurality based on a discrete Fourier transform matrix.

**27.** A method for communicating information in a multiple input multiple output (MIMO) communications system, the method comprising:

constructing a mixed mode protocol data unit (PDU) comprising, a legacy short training sequence field comprising a time duration of approximately 8 microseconds;

appending a legacy long training sequence field comprising a time duration of approximately 8 microseconds, subsequent to said legacy short training sequence field;

appending a legacy signal field comprising a time duration of approximately 4 microseconds, subsequent to said legacy long training field;

appending a high throughput signal field comprising a time duration of approximately 8 microseconds, subsequent to said legacy signal field;

appending a high throughput short training sequence field comprising a time duration of approximately 3.2 microseconds, subsequent to said high throughput signal field; and

appending a plurality of long training sequence fields, comprising a time duration of approximately 4 microseconds, subsequent to said high throughput short training sequence field.

\* \* \* \* \*