

Provisional Application for Patent Cover Sheet
 This is a request for filing a PROVISIONAL APPLICATION FOR PATENT under 37 CFR 1.53(c)

Inventor(s)

Inventor 1

Given Name	Middle Name	Family Name	City	State	Country
Joon	Bae	Kim	Lexington	MA	US

Inventor 2

Given Name	Middle Name	Family Name	City	State	Country
Marcos		Tzannes	Orinda	CA	US

All Inventors Must Be Listed – Additional Inventor Information blocks may be generated within this form by selecting the **Add** button.

Title of Invention Header Repetition Scheme in Packet-based OFDM Systems

Attorney Docket Number (if applicable) 5550-87-PROV

Correspondence Address
 Direct all correspondence to (select one):

<input checked="" type="radio"/> The address corresponding to Customer Number	<input type="radio"/> Firm or Individual Name
Customer Number	62574

The invention was made by an agency of the United States Government or under a contract with an agency of the United States Government.

No.

Yes, the name of the U.S. Government agency and the Government contract number are:

Entity Status					
Applicant claims small entity status under 37 CFR 1.27					
<input type="radio"/> Yes, applicant qualifies for small entity status under 37 CFR 1.27 <input checked="" type="radio"/> No					
Warning					
<p>Petitioner/applicant is cautioned to avoid submitting personal information in documents filed in a patent application that may contribute to identity theft. Personal information such as social security numbers, bank account numbers, or credit card numbers (other than a check or credit card authorization form PTO-2038 submitted for payment purposes) is never required by the USPTO to support a petition or an application. If this type of personal information is included in documents submitted to the USPTO, petitioners/applicants should consider redacting such personal information from the documents before submitting them to USPTO. Petitioner/applicant is advised that the record of a patent application is available to the public after publication of the application (unless a non-publication request in compliance with 37 CFR 1.213(a) is made in the application) or issuance of a patent. Furthermore, the record from an abandoned application may also be available to the public if the application is referenced in a published application or an issued patent (see 37 CFR 1.14). Checks and credit card authorization forms PTO-2038 submitted for payment purposes are not retained in the application file and therefore are not publicly available.</p>					
Signature					
Please see 37 CFR 1.4(d) for the form of the signature.					
Signature	/Jason H. Vick/			Date (YYYY-MM-DD)	2009-08-21
First Name	Jason H.	Last Name	Vick	Registration Number (If appropriate)	45285
<p>This collection of information is required by 37 CFR 1.51. The information is required to obtain or retain a benefit by the public which is to file (and by the USPTO to process) an application. Confidentiality is governed by 35 U.S.C. 122 and 37 CFR 1.11 and 1.14. This collection is estimated to take 8 hours to complete, including gathering, preparing, and submitting the completed application form to the USPTO. Time will vary depending upon the individual case. Any comments on the amount of time you require to complete this form and/or suggestions for reducing this burden, should be sent to the Chief Information Officer, U.S. Patent and Trademark Office, U.S. Department of Commerce, P.O. Box 1450, Alexandria, VA 22313-1450. DO NOT SEND FEES OR COMPLETED FORMS TO THIS ADDRESS. This form can only be used when in conjunction with EFS-Web. If this form is mailed to the USPTO, it may cause delays in handling the provisional application.</p>					

Privacy Act Statement

The Privacy Act of 1974 (P.L. 93-579) requires that you be given certain information in connection with your submission of the attached form related to a patent application or patent. Accordingly, pursuant to the requirements of the Act, please be advised that : (1) the general authority for the collection of this information is 35 U.S.C. 2(b)(2); (2) furnishing of the information solicited is voluntary; and (3) the principal purpose for which the information is used by the U.S. Patent and Trademark Office is to process and/or examine your submission related to a patent application or patent. If you do not furnish the requested information, the U.S. Patent and Trademark Office may not be able to process and/or examine your submission, which may result in termination of proceedings or abandonment of the application or expiration of the patent.

The information provided by you in this form will be subject to the following routine uses:

1. The information on this form will be treated confidentially to the extent allowed under the Freedom of Information Act (5 U.S.C. 552) and the Privacy Act (5 U.S.C. 552a). Records from this system of records may be disclosed to the Department of Justice to determine whether disclosure of these records is required by the Freedom of Information Act.
2. A record from this system of records may be disclosed, as a routine use, in the course of presenting evidence to a court, magistrate, or administrative tribunal, including disclosures to opposing counsel in the course of settlement negotiations.
3. A record in this system of records may be disclosed, as a routine use, to a Member of Congress submitting a request involving an individual, to whom the record pertains, when the individual has requested assistance from the Member with respect to the subject matter of the record.
4. A record in this system of records may be disclosed, as a routine use, to a contractor of the Agency having need for the information in order to perform a contract. Recipients of information shall be required to comply with the requirements of the Privacy Act of 1974, as amended, pursuant to 5 U.S.C. 552a(m).
5. A record related to an International Application filed under the Patent Cooperation Treaty in this system of records may be disclosed, as a routine use, to the International Bureau of the World Intellectual Property Organization, pursuant to the Patent Cooperation Treaty.
6. A record in this system of records may be disclosed, as a routine use, to another federal agency for purposes of National Security review (35 U.S.C. 181) and for review pursuant to the Atomic Energy Act (42 U.S.C. 218(c)).
7. A record from this system of records may be disclosed, as a routine use, to the Administrator, General Services, or his/her designee, during an inspection of records conducted by GSA as part of that agency's responsibility to recommend improvements in records management practices and programs, under authority of 44 U.S.C. 2904 and 2906. Such disclosure shall be made in accordance with the GSA regulations governing inspection of records for this purpose, and any other relevant (i.e., GSA or Commerce) directive. Such disclosure shall not be used to make determinations about individuals.
8. A record from this system of records may be disclosed, as a routine use, to the public after either publication of the application pursuant to 35 U.S.C. 122(b) or issuance of a patent pursuant to 35 U.S.C. 151. Further, a record may be disclosed, subject to the limitations of 37 CFR 1.14, as a routine use, to the public if the record was filed in an application which became abandoned or in which the proceedings were terminated and which application is referenced by either a published application, an application open to public inspection or an issued patent.
9. A record from this system of records may be disclosed, as a routine use, to a Federal, State, or local law enforcement agency, if the USPTO becomes aware of a violation or potential violation of law or regulation.

1 PROVISIONAL PATENT APPLICATION

Header Repetition Scheme in Packet-based OFDM Systems

2 INVENTORS

Joon Bae Kim
Marcos Tzannes

3 BRIEF OVERVIEW OF AN EXEMPLARY EMBODIMENT OF THE INVENTION

This invention describes methods to facilitate nodes (devices) using different repetition schemes for their header transmission to communicate with one another in a single domain (network) in the presence of nodes operating on partial bandwidth (e.g., reduced sampling rate).

4 BACKGROUND

Conventional multi-user communication systems use frame-based (or packet-based) transmission to communicate between two or more users over a shared channel based on OFDM. A packet is usually formed by preamble, header, and payload, and transmitted using time-sharing or contention-based media access methods. The example of such system includes IEEE 802.11 (Wireless LAN), IEEE 802.16 (WiMAX), and ITU G.9960 (G.hn). These systems use OFDM transmission (also referred to sometimes as Discrete Multi-Tone (DMT)) which divides the transmission frequency band into multiple subcarriers (also referred to as tones or sub-channels), with each sub-carrier individually modulating a bit or a collection of bits.

The header contains important control information for the receiver to decode the payload properly, and also provides information about the packet length for virtual carrier sensing. Hence it is essential to decode the header reliably. In G.9960 the header containing PHY_H bits (header information block) is carried over one or two OFDM symbols ($D = 1$ or 2), and within each symbol, multiple header information blocks are repeated over the entire frequency band [1]. The default value of D is 1, but expanding it to 2 in some cases is under discussion [2, 3]. The possibility of carrying more than PHY_H bits in the header ($H = 1$ or 2) is also under discussion [2, 4].

5 TECHNICAL DESCRIPTION OF THE INVENTION

What has not been discussed is allowing different values of D in a single domain where nodes are operating in different portions of frequency bands. For the power-line medium, G.9960 has defined two overlapped baseband bandplans, 50MHz-PB and 100MHz-PB. The possibility of having narrower bandplans such as 25MHz-PB and 12.5MHz-PB are under discussion in order to support SmartGrid applications. In this scenario, the level of frequency diversity is different depending on the bandplan, hence provides different header decodibility if D is fixed to 1. If D is fixed to 2, then it increases

reliability for the narrow band devices, but unnecessarily increases overhead for the wide-band devices.

This invention describes methods to accommodate different repetition schemes ($D = 1, \dots, D_{MAX}$ and $H = 1, \dots, H_{MAX}$) in a single domain, and still allow devices to communicate with one another. D_{MAX} and H_{MAX} can be larger than 2.

5.1 Example of header repetition when D, H = 1 or 2

Figure 1 describes the header repetition scheme when D, H = 1 or 2.

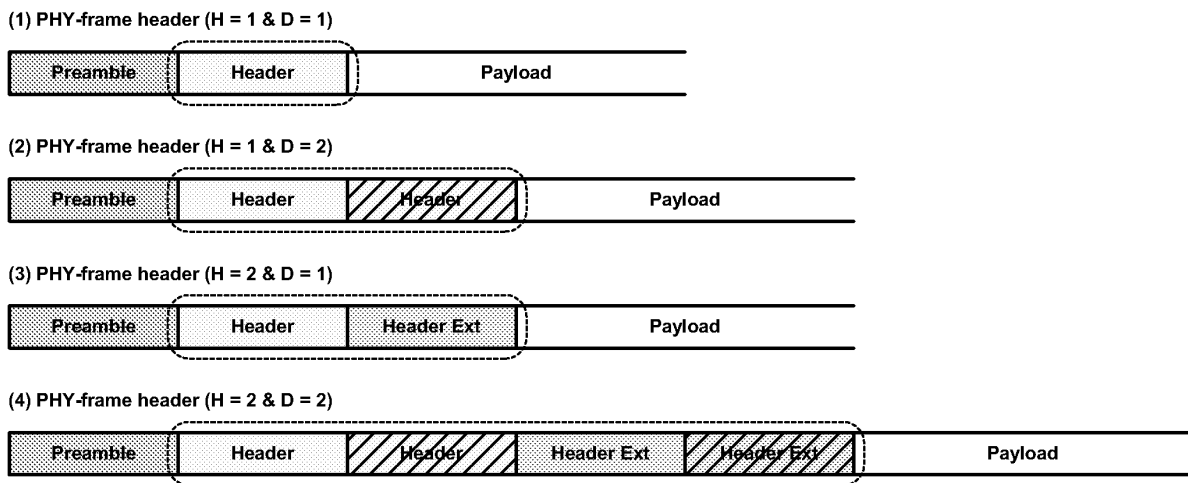

Figure 1: Header repetition scheme (D, H = 1 or 2)

The shaded block represents the copy of the unshaded block with the same label. The modulation of the copied block may not be exactly the same as its original version. The label “Header Ext” emphasizes the fact that it contains different header information than “Header”. The payload after the header may be omitted in some cases (e.g., ACK, RTS/CTS). The repetition scheme expands similarly with larger values of D_{MAX} and H_{MAX} . The invention focuses on dealing with different values of D . Different values of H can be supported in straightforward way as proposed in [2].

5.2 Detection by receiver (variable repetition)

In this exemplary embodiment, the transmitter selects (or determines) at least one D value. This selection may be at its own discretion, or based on information communicated between one or more receivers, or based on instruction from one or more receivers. Selection may depend on the number of available sub-carriers (or the bandwidth) of the bandplan the transmitter operates on and/or the receiver(s) operates on. In this exemplary embodiment a receiving node in the domain should be able to decode packets sent by the transmitter without knowing D a priori (i.e. prior to decoding the packet header).

One exemplary method is for a transmitter to carry the value of D in the header so that all nodes know how many OFDM symbols are carrying header information. The receiver starts processing the header

by decoding one OFDM header symbol. If the receiver decodes it successfully, then it knows how many more OFDM symbols ($D-1$) carrying header information for a given frame. If the receiver fails to obtain header information out of one OFDM header symbol (i.e. the header decoding fails), then it can try to decode two OFDM header symbols, and so on. The decoding of each additional OFDM header symbol provides additional diversity thereby increasing the likelihood of decoding the header information correctly.

5.3 Fixed repetition scheme per domain

In one exemplary embodiment, the domain master selects (or determines) one or more fixed D values for at least one node in the domain. For example, the domain master may select one fixed value for all nodes in a domain. Selection may depend on the number of available sub-carriers (or the bandwidth) of the bandplans that the domain members operate on. The domain master may change the value of D dynamically. A node in the domain first needs to determine the D that the domain master has set (or selected/determined).

One exemplary method is for the domain master to carry the selected value of D in the header of the MAP frame while also using this D value for the transmission of the MAP header (as described in §5.1). In this case, a node will determine out this D value using the methods described in §5.1. After this value is determined by a node, the node will use this value until it is changed by the domain master.

Other exemplary method is for the domain master to carry the selected value of D in the MAP and while using a fixed D for the header of the MAP frame (e.g., pre-defined per medium or D_{MAX}). The D value in the MAP will be used for non-MAP frames/packets. In this case a node in the domain does not need multiple levels of header decode process (as described in §5.1). Also in this exemplary method, the MAP may be sent with a different D value than the D value used for other (non-MAP) frames/packets.

5.4 Fixed repetition scheme per TXOP

Additionally or alternately, the domain master may select (or determine) a D value per TXOP. This selection may be at its own discretion, or based on information communicated between one or more receivers, or based on instruction from one or more receivers. Selection may depend on the number of available sub-carriers (or the bandwidth) of the bandplan the transmitter operates on and/or the receiver(s) operates on.

One exemplary method is to include D in the TXOP descriptor transmitted in the MAP so that all nodes know in advance what values of D is used for that TXOP. TXOP descriptor is the part of the MAP message which can be communicated via the MAP frame as described in §5.2.

6 GENERAL TERMS

The terms *subcarrier*, *subchannel* and *tone* have the same meaning and are used interchangeably in the description.

The terms *receiver*, *receiving node* and *receiving transceiver* have the same meaning and are used interchangeably in the description.

The term *transmitter*, *transmitting node* and *transmitting transceiver* have the same meaning and are used interchangeably in the description.

The terms *transceiver* and *modem* have the same meaning and are used interchangeably in the description.

The term *frame* and *packet* have the same meaning and are used interchangeably in the description. The term *header* and *PHY-frame header* have the same meaning and are used interchangeably in the description.

The terms *network* and *home network* have the same meaning and are used interchangeably in the description. While the term Home network has been used in this description, the description is not limited to home networks but in fact applies also to any network, such as enterprise networks, business networks, or any network with a plurality of connected nodes.

The above-described methods and systems and can be implemented in a software module, a software and/or hardware testing module, a telecommunications test device, a DSL modem, an ADSL modem, an xDSL modem, a VDSL modem, a linecard, a G.hn transceiver, a MOCA transceiver, a Homeplug transceiver, a powerline modem, a wired, a wireless modem such as 802.11a/g/n or 802.16, test equipment, a multicarrier transceiver, a wired and/or wireless wide/local area network system, a satellite communication system, network-based communication systems, such as an IP, Ethernet or ATM system, a modem equipped with diagnostic capabilities, or the like, or on a separate programmed general purpose computer having a communications device or in conjunction with any of the following communications protocols: CDSL, ADSL2, ADSL2+, VDSL1, VDSL2, HDSL, DSL Lite, IDSL, RADSL, SDSL, UDSL, MOCA, G.hn, Homeplug or the like.

Additionally, the systems, methods and protocols of this invention can be implemented on a special purpose computer, a programmed microprocessor or microcontroller and peripheral integrated circuit element(s), an ASIC or other integrated circuit, a digital signal processor, a flashable device, a hard-wired electronic or logic circuit such as discrete element circuit, a programmable logic device such as PLD, PLA, FPGA, PAL, a modem, a transmitter/receiver, any comparable means, or the like. In general, any device capable of implementing a state machine that is in turn capable of implementing the methodology illustrated herein can be used to implement the various communication methods, protocols and techniques according to this invention. While the systems and means disclosed herein are described in relation to various functions that are performed, it is to be appreciated that the systems and means may not always perform all of the various functions, but are capable of performing one or more of the disclosed functions.

Furthermore, the disclosed methods may be readily implemented in software using object or object-oriented software development environments that provide portable source code that can be used on a variety of computer or workstation platforms. Alternatively, the disclosed system may be implemented partially or fully in hardware using standard logic circuits or VLSI design. Whether software or hardware is used to implement the systems in accordance with this invention is dependent on the speed and/or efficiency requirements of the system, the particular function, and the particular software or hardware systems or microprocessor or microcomputer systems being utilized. The communication systems, methods and protocols illustrated herein can be readily implemented in hardware and/or software using any known or later developed systems or structures, devices and/or software by those of ordinary skill in the applicable art from the functional description provided herein and with a general basic knowledge of the computer and telecommunications arts.

Moreover, the disclosed methods may be readily implemented in software that can be stored on a computer-readable storage medium, executed on programmed general-purpose computer with the cooperation of a controller and memory, a special purpose computer, a microprocessor, or the like. In these instances, the systems and methods of this invention can be implemented as program embedded on personal computer such as an applet, JAVA® or CGI script, as a resource residing on a server or computer workstation, as a routine embedded in a dedicated communication system or system component, or the like. The system can also be implemented by physically incorporating the system and/or method into a software and/or hardware system, such as the hardware and software systems of a test/modeling device.

While the invention is described in terms of exemplary embodiments, it should be appreciated that individual aspects of the invention could be separately claimed and one or more of the features of the various embodiments can be combined.

While the systems and means disclosed herein are described in relation to various functions that are performed, it is to be appreciated that the systems and means may not always perform all of the various functions, but are capable of performing one or more of the disclosed functions.

While the exemplary embodiments illustrated herein discuss the various components collocated, it is to be appreciated that the various components of the system can be located a distant portions of a distributed network, such as a telecommunications network and/or the Internet or within a dedicated communications network. Thus, it should be appreciated that the components of the system can be combined into one or more devices or collocated on a particular node of a distributed network, such as a telecommunications network. As will be appreciated from the following description, and for reasons of computational efficiency, the components of the communications network can be arranged at any location within the distributed network without affecting the operation of the system.

It is therefore apparent that there has been provided, in accordance with the present invention, systems and methods for detecting unfiltered device(s). While this invention has been described in conjunction with a number of embodiments, it is evident that many alternatives, modifications and variations would be or are apparent to those of ordinary skill in the applicable arts. Accordingly, it is intended to embrace all such alternatives, modifications, equivalents and variations that are within the spirit and scope of this invention.

7 CLAIMS

1. A method for allowing different values of D in a single domain where nodes are operating in different portions of frequency bands.
2. A method to accommodate different repetition schemes ($D = 1, \dots, D_{MAX}$ and $H = 1, \dots, H_{MAX}$) in a single domain, and still allow devices to communicate with one another. D_{MAX} and H_{MAX} can be larger than 2.

8 REFERENCE

- [1] Editor for G.9960, "ITU-T Recommendation G.9960: Next generation wire-line based home networking transceivers – Foundation," *ITU-T SG15/Q4*, Jan. 2009.
- [2] Aware, "G.hn: PHY-Frame Header Extension," *ITU-T SG15/Q4 09CC-046*, Concord, California, Aug. 2009.

- [3] CopperGate, "G.hn: Using Two Symbols for the Header of a PHY frame on Coax," *ITU-T SG15/Q4 09XC-100*, Xian, China, Jul. 2009.
- [4] Intellon, "G.hn: Extended PHY frame header," *ITU-T SG15/Q4 09XC-119*, Xian, China, Jul. 2009.

Concord, California, 24 – 28 August 2009

Question: 4/15

SOURCE¹: Aware

TITLE: **G.hn: PHY-Frame Header Extension**

ABSTRACT

This contribution proposes a generic PHY-frame header extension scheme to incorporate larger than PHY_H bits in the header (Issue 5.0.1.2.1.0.13). It also proposes not to fix the number of header repetitions (*D*) unconditionally for any given medium since the wide range of bandplans shall be accommodated effectively in a single domain (Issue 5.0.1.2.1.2.0.1).

| [Introduction](#) | [Proposal](#) | [Text Update](#) | [Summary](#) |

¹ Contact: Joon Bae Kim
Aware, Inc.

T: +1 781 276 4000
E: jbkim@aware.com

1 Introduction

The group has been discussing PHY-frame header extension in two different aspects, (1) increasing the number of information bits carried in the PHY-frame header, and (2) repeating the same header information over two OFDM symbols for enhanced diversity combination. We need to have a generic and consistent approach to accomplish these two goals.

In 09CV meeting the group agreed to specify a scheme to extend the PHY-frame header so that larger than PHY_H bits can be accommodated in the PHY-frame header (Issue 5.0.1.2.1.0.13). This contribution proposes a generic scheme to extend the PHY-frame header. The proposed scheme makes G.hn future-proof, and it can be immediately used to support bi-directional transmission proposed by [4].

Item Number	Status	Item Description	Reference(s)
5.0.1.2.1.0.13	Agreed 8-Apr-09	That G.hn shall specify means to extend the PHY-frame header.	09CV-042

In 09XC meeting the group provisionally agreed that the number of PHY-frame header repetitions (D) shall be set to 2 in the coax medium since the number of available sub-carriers in coax 50MHz bandplan (256) is not enough to guarantee the reliability of PHY-frame header (Issue 5.0.1.2.1.2.0.1).

Item Number	Status	Item Description	Reference(s)
5.0.1.2.1.2.0.1	Agreed 30-July-09	Provisionally, that the value of D shall be 2 for the coax medium (baseband and RF) subject to there not being any alternative proposal submitted by the upload deadline for the Q4/15 G.hn meeting August 2009.	09XC-100

2 Proposal

For extending the capability of carrying more than PHY_H bits in the PHY-frame header, we propose the followings:

- ❑ Add a bit (Extended Header Indication: EHI) in the original PHY-frame header fields (Table 7-1) to indicate whether or not the header extension is applied.
- ❑ Define a generic field description for the extended part of the header in §7.1.2.3.3 (new section), which is also PHY_H bits long, and contains the common part (e.g., E_HCS) and variable part (e.g., E_FTSF).

The text update is proposed in the following section.

For specifying the number of PHY-frame header repetitions (D), we propose not to fix D per medium, rather to define a technique to use different values of D . Although it is understood that more repetitions may be necessary in coax, fixing D unconditionally for any given medium is neither a flexible nor an efficient solution because

- ❑ Even in the power line medium we may face the similar situation as narrower bandplans are added to support SmartGrid applications (Issue 1.90.10.1). In this case we need a flexible scheme to support narrow and wide bandplans at the same time.

Item Number	Status	Item Description	Reference(s)
1.90.10.1	Agreed 31-July-09	That G.hn shall specify: <ul style="list-style-type: none"> • Extensions to support the Smart Grid applications • A profile that is applicable to Smart Grid for devices that need to satisfy the requirements in terms of data rate, QoS, power consumption and device complexity. 	09CX-104

- ❑ Applying $D = 2$ uniformly for all bandplans in coax makes G.hn less efficient for wide bandplans (e.g., 200MHz-CRF) as well as over the legacy system.

The possible cases of PHY-frame header transmissions are shown in the following figure.

(1) PHY-frame header without extension & $D = 1$



(2) PHY-frame header without extension & $D = 2$



(3) PHY-frame header with extension & $D = 1$



(4) PHY-frame header with extension & $D = 2$



3 Text Update

3.1 Existing text update for G.9960 Amendment 1

Text is updated based on [3] with all changes accepted.

<Start of text>

7.1.2.3 PHY-frame header

The core part of the PHY-frame header is PHY_H bits long and is composed of a common part and a variable part. The common part contains fields that are common for all PHY-frame types. The variable part contains fields according to the PHY-frame type. PHY-frame type is indicated by the FT field. The PAD fields fit the length of the header of different PHY frame-types to the standard values of PHY_H bits. The content of the header-core part is protected by the 16-bit header check sequence (HCS).

The fields of the core part of the PHY-frame header are defined in Table 7-1.

Depending on the frame type, the PHY-frame header may be extended to $2 \times PHY_H$ bits long. If the extended header indication (EHI) bit is set, then additional PHY_H information bits of the extended part of the PHY-frame header are appended at the end of the core part of the PHY-frame header. The extended part of the PHY-frame header shall be encoded exactly the same way as the core part as described in §7.1.3.4.

Table 7-1/G.9960 – Core part of PHY-frame header fields

Field	Octet	Field Size [Bits]	Description	
FT	0	4	Frame type	Common part
DOD	0	4	Domain ID	
SID	1	8	The device ID of the source node	
DID	2	8	The device ID of the destination node(s)	
MI	3	1	Multicast indication identifies whether the DID is a multicast destination	
PHI	3	1	Post header indication identifies whether the first payload symbol after the header is a PRBS symbol or a data symbol	
EHI	3	1	Extended header indication	
Reserved	3	56	Reserved by ITU-T	
Duration	4-5	16	The PHY frame transmission duration	
...	6-18			Variable part
HCS	19-20	16	Header check sequence	Common part

<End of text>

3.2 New text for G.9960 Amendment 1

Text is added based on [3] with all changes accepted.

<Start of text>

7.1.2.3.1.6 Post Header Indication (PHI)

The PHI bit, when set, shall indicate that the first payload symbol following the header is a PRBS symbol. Otherwise the first payload symbol shall be a data symbol.

7.1.2.3.1.7 Extended Header Indication (EHI)

The EHI field, when set, shall indicate that the PHY frame header contains $2 \times \text{PHY}_H$ information bits. The additional PHY_H information bits of the extended part of the PHY-frame header are specified in §7.1.2.3.3. If the EHI field is zero, then the PHY-frame header shall contain PHY_H information bits. The EHI field shall be set according to the frame type.

<End of text>

<Start of text>

7.1.2.3.3 Extended header fields

The extended part of the PHY-frame header is PHY_H bits long and is composed of a common part and a variable part. The common part contains fields that are common for all PHY-frame types. The variable part contains fields according to the PHY-frame type. PHY-frame type is indicated by the FT field in the core part of the PHY-frame header. The PAD fields fit the length of the header of different PHY frame-types to the standard values of PHY_H bits. The content of the extended part is protected by the 16-bit header check sequence (E_HCS).

The fields of the extended part of the PHY-frame header are defined in Table 7-XY.

Table 7-XY/G.9960 – Extended part of PHY-frame header fields

Field	Octet	Field Size [Bits]	Description	
E_FTSE	9-18	152	Extended frame-type specific fields	Variable part
E_HCS	19-20	16	Extended header check sequence	Common part

7.1.2.3.3.1 Extended frame-type specific fields (E_FTSE)

This is for further study.

7.1.2.3.3.2 Extended header check sequence (E_HCS)

The E_HCS field is intended for verification of the extended part of the PHY-frame header. The E_HCS is a 16-bit cyclic redundancy check (CRC) and shall be computed over all the fields of the E_FTSE in the order they are transmitted, starting with the LSB of the first field and ending with the MSB of the last field of E_FTSE. The same polynomial described in §7.1.2.3.1.8 shall be used.

<End of text>

4 References

- [1] Editor for G.hn, “G.hn: Draft Text for G.hn – version 4.1,” *ITU-T SG15/Q4 09CC-R12*, Concord, California, Aug. 2009.
- [2] Editor for G.hn, “G.hn: Updated Issues List for G.hn,” *ITU-T SG15/Q4 09XC-U12R1*, Xian, China, Jul. 2009.
- [3] Editor for G.hn, “ITU-T Recommendation G.9960 Unified high-speed wire-line based home networking transceivers - Foundation,” *ITU-T SG15/Q4 G.9960 LC comment resolution draft text R8*, Concord, California, Aug. 2009.

- [4] Intellon, “G.hn: Bi-directional transmissions,” *ITU-T SG15/Q4 09XC-113R1*, Xian, China, Jul. 2009.

| [Introduction](#) | [Proposal](#) | [Text Update](#) | [Summary](#) |

5 Summary

1. This paper proposes to agree on the following new issues.

Item Number	Status	Item Description	Reference(s)
5.0.1.2.1.0.13.1 (New)	Open	Should the following sections of text be revised or added to G.9960 Amendment 1 as working text: <ul style="list-style-type: none"> • §7.1.2.3 “PHY-frame header”, • §7.1.2.3.1.7 “Extended Header Indication (EHI)”, • §7.1.2.3.3 “Extended header fields”, • §7.1.2.3.3.1 “Extended frame-type specific fields (E_FTSF)”, and • §7.1.2.3.3.2 “Extended header check sequence (E_HCS)”? 	09CC-046
5.0.1.2.1.0.13.2 (New)	Open	Should G.hn adopt the PHY-frame header extension scheme proposed in 09CC-046?	09CC-046
5.0.1.2.1.2.0.1.1 (New)	Open	Should the G.hn define a technique to use different values of D for any given medium rather than use a fixed value (response to the provisional agreement in Issue 5.0.1.2.1.2.0.1)?	09CC-046

Xian, China – 27 – 31 July 2009

Question: 4/15

SOURCE¹: CopperGate CommunicationsTITLE: G.hn: Using Two Symbols for the Header of a PHY frame on Coax

ABSTRACT

The contribution proposes that the number of symbols used for the header of the PHY frame on coax (baseband and RF) be fixed to two exactly. The reason for this proposal is that a single symbol does not provide adequate reliability for the 50 MHz case, as shown below.

1. Introduction

The PHY-header of a PHY-frame is defined in G.9960 [1] to contain important information necessary in order to process the payload. The information of the header is encoded in a single FEC block of 168 bits with code rate 1/2. This information is modulated onto either one or two OFDM symbols using QPSK modulation. The effective number of repetitions depends on the number of active subcarriers and on the number of header symbols (1 or 2).

It is not specified what the conditions for choosing one or two symbols are. The intention is that there will be a sufficient number of repetitions of the FEC block so that some minimum level of robustness is guaranteed.

A straightforward calculation can be carried out in order to assess the required number of OFDM symbols. Let us consider the more challenging setting of 50 MHz devices on coax. Both for baseband and RF, the number of subcarriers is 256. Since the header is modulated using QPSK and rate 1/2 a single copy of the PHY-header FEC block takes 168 subcarriers. Obviously, there is only room for a single complete copy of the FEC block. This situation is problematic, because the header does not have any advantage over the payload in terms of robustness.

Decoding a 136-bit FEC block with a BLER level of 10^{-6} requires an SNR of 5 dB or so. On the other hand, decoding a 520-byte FEC block with a BLER level of 10^{-6} requires an SNR of about 3.5 dB – some 1.5 dB less.

It is reasonable to approximate that if there are N copies of a FEC block then it acquires an extra coding gain of $10\log_{10}(N)$, even if N is non integer. If we assume that 0.9 of the band is utilized then this means there are $256 \times 0.9 / 168 = 1.4$ repetitions per symbol, which provide a gain of 1.5 dB. This

makes the header about as robust as a payload encoded using a FEC block of 520 bytes with code rate 1/2 and QPSK modulation.

This contribution proposes to *always* use two header symbols on coax. The number of subcarriers in two OFDM symbols is 512, which is barely sufficient to accommodate 3 full copies of the header, which require $3 \times 168 = 504$ subcarriers. Note that in practice some guard bands are expected near the band edges. In this case, even 3 full repetitions will not fit in.

2. Proposal

It is proposed to incorporate the following text additions to [2] G.hn: Draft text for G.9960 Amendment 1 – version 4.0.

<<Start of Text>>

7.1.3.4 Header encoder

The functional model of the header encoder is presented in Figure 7-10. It contains an FEC encoder and a Header Repetition Encoder (HRE).

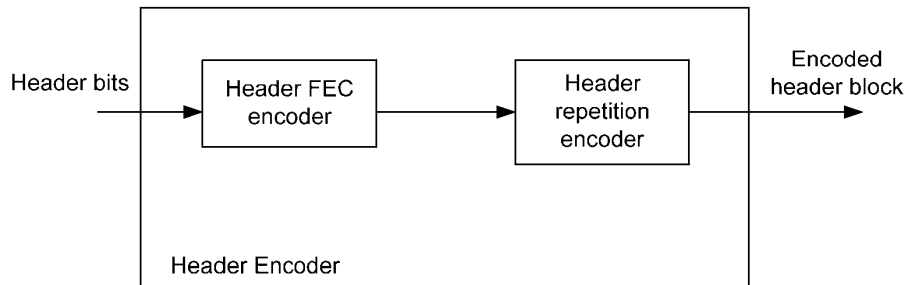

Figure 7-10/G.9960 – Functional diagram of the Header Encoder

The bits of the PHY-frame header shall input the Header FEC encoder in their original order and encoded as described in §7.1.3.2. The size of the FEC codeword and the coding rate of the Header FEC encoder are described in Table 7-19.

The FEC codeword enters the HRE. The HRE shall operate as follows:

- The FEC codeword shall be first copied M times, where $M = \text{ceiling}(D \times k_H / N_{FEC})$, k_H is the number of bits to be loaded onto the OFDM symbol carrying the header, and D is the number of symbols to be used for header transmission
- The encoded header block shall be formed by concatenation of M copies of the header FEC encoder output. As each codeword is cascaded to one another, the bits (b_i) within a codeword shall be cyclically shifted by 2 bits as follows:
 - The 1st FEC codeword copy shall be formed as $\{b_0, b_1, \dots, b_{N_{FEC}-2}, b_{N_{FEC}-1}\}$.
 - The 2nd FEC codeword copy shall be formed as $\{b_2, b_3, \dots, b_{N_{FEC}-1}, b_0, b_1\}$.
 - The 3rd FEC codeword copy shall be formed as $\{b_4, b_5, \dots, b_{N_{FEC}-1}, b_0, b_1, b_2, b_3\}$.
 - ...

- The M^{th} FEC codeword copy, where $M > 3$, shall be formed as $\{b_{(2 \times M - 2)}, b_{(2 \times M - 1)}, \dots, b_{N_{\text{FEC}} - 1}, b_0, b_1, \dots, b_{(2 \times M - 4)}, b_{(2 \times M - 3)}\}$.

Valid values of D are either 1 or 2. Details for powerline and phoeline are for further study.

For coax (baseband and RF) the number of PHY-frame header shall be two, i.e., $D = 2$.

NOTE: Since the coding rate used for header encoding is $\frac{1}{2}$, the number of bits in the FEC codeword is always even, and the number of bits in the encoded header block is even.

<<End of Text>>

3. References

- [1] G.9960 LC comment resolution draft text R7.doc “ITU-T Recommendation G.9960, Unified high-speed wire-line based home networking transceivers - Foundation”, Editor for G.hn, Baltimore Maryland, 18 – 26 May 2009.
- [2] 09XC-R12a, “G.hn: Draft text for G.9960 Amendment 1 – version 4.0”, Xian, China – 27 – 31 July 2009.

4. Summary

It is proposed to agree on the following new items.

New item 5.0.1.2.1.2.0.1		Open	Should the PHY-frame header include exactly two OFDM symbols for coax (baseband and RF)?	09XC-100
New item 5.0.1.2.1.2.0.2		Open	Should the text changes proposed in Sec 2 of 09XC-100 be adopted into 09XC-R12a?	09XC-100

Xi'an China – 27 – 31 July 2009

Question: 4/15

SOURCE¹: Intellon Corporation

TITLE: **G.hn: Extended PHY frame header**

ABSTRACT

This contribution proposes to add an option for supporting extended PHY frame headers that contain 2 x PHY_H information bits in order to allow for expansion of the ACKI field and to allow additional header bits for future enhancements to G.9960.

| [Introduction](#) | [First Heading](#) | [Second Heading](#) | [Summary](#) |

1. Introduction

The G.9960 draft in §7.1.2.1 alludes to PHY frame headers that contain more than one symbol (although the reference does not make it clear if this is for PHY frame header symbol repetition or to support additional PHY frame header information bits), and support for extended PHY frame headers with additional information bits that are encoded with double the symbols used for the non-extended PHY frame header has been discussed in the G.hn group. However, currently, the current text (G.9960 draft, G.9960 Amendment I, or G.hn draft) does not describe support for more than PHY_H information bits in the PHY frame header.

This contribution proposes to add an option for supporting an extended PHY frame header with 2 x PHY_H information bits in order to allow for expansion of the ACKI field and to allow additional header bits for future enhancements to G.9960. A larger ACKI field allows more frames to be acknowledged, and is especially useful for bi-directional transmissions, which is proposed in separate contribution.

Proposed is to define two one-bit fields which are assigned to bits in the PHY frame header that are currently reserved. The extended header indication (EHI) is set to indicate that the PHY header contains 2 x PHY_H information bits, allowing receivers to determine how to decode the PHY header.

The immediate response frame extended header indication (IREHI) tells receivers if they should respond with a header than contains PHY_H or 2 x PHY_H information bits when transmitting immediate response frames. This allows receivers to know if sufficient time has been allocated for a immediate response frame and for nodes tracking durations to know the duration of a frame transmission sequence. If at some point the definition of the duration field is modified so that it includes immediate response frames (ACK frame), then it may be possible to eliminate the IREHI bit.

This contribution proposes two HCS fields to independently protect the content of each set of PHY_H information bits in the PHY header. Two independent HCS fields results more robust protection of the header contents. It also eliminates ambiguity for receivers when determining how to decode the PHY frame header. If a single HCS field were to be defined that protected 2 x PHY_H information bits then the IREHI bit would need to be interpreted and acted on before the bit is verified with the HCS.

¹Contacts: Sid Schrum, Intellon Corporation

sid.schrum@intellon.com

2. Proposed Text Updates

<<Start Text – G.9960 Amendment I>>

7.1.2.3 PHY-frame header

The PHY-frame header contains ~~is~~ PHY_H information bits if the extended header information (EHI) bit is set to zero, and 2 x PHY_H information bits if the EHI bit is set to one, ~~and~~ and is composed of a common part and a variable part. The common part contains fields that are common for all PHY-frame types. The variable part contains fields according to the PHY-frame type. PHY-frame type is indicated by the FT field. The PAD fields fit the length of the header of different PHY frame-types to the standard values of PHY_H bits. The content of the header is protected by the 16-bit header check sequences (HCS₁ and E_HCS in the case of the extended PHY header).

The fields of the PHY-frame header are defined in Table 7-1

Table 7-1/G.9960 – PHY-frame header fields

Field	Octet	Field Size [Bits]	Description	
FT	0	4	Frame type	Common part
DOD	0	4	Domain ID	
SID	1	8	The device ID of the source node	
DID	2	8	The device ID of the destination node	
MI	3	1	Multicast indication identifies whether the DID is a multicast destination	
PHI	3	1	Post header indication identifies whether the first payload symbol after the header is a PRBS symbol or a data symbol	
EHI	3	1	Extended PHY frame header indication.	
IREHI	3	1	Immediate response frame extended PHY frame header indication.	
Reserved	3	46	Reserved by ITU-T	
Duration	4-5	16	The PHY frame transmission duration	
...	6-18			Variable part
HCS	19-20	16	Header check sequence	Common part
	21-39 [1]			Variable part 2 (present for extended PHY frame header only)
E_HCS	40-41 [1]	16	Extended PHY header - header check sequence	Common part (present for extended PHY frame header only)
Notes [1] These fields are present only if the EHI bit is set.				

7.1.2.3.1.8 Extended header indication (EHI)

The EHI field when set indicates that the PHY frame header contains 2 x PHY_H information bits. If the EHI field is zero then the header of the PHY frame contains PHY_H information bits. The EHI field shall be set to zero for all frames types except the ACK frame. In ACK frames this bit may be set to zero or one.

7.1.2.3.1.9 Immediate response frame extended header indication (IREHI)

The IREHI field when set indicates that receivers shall use for immediate response frames (ACK for example) extended PHY-frame headers. If the IREHI field is zero then immediate response frames shall use standard (non-extended) PHY-frame headers.

7.1.2.3.1.3 Header check sequence and Extended header check sequence (HCS and E_HCS)

The HCS and E_HCS fields are intended for PHY-frame header verification. The HCS is a 16-bit cyclic redundancy check (CRC) and shall be computed over all the fields of the first PHY_H information bits of the PHY-frame header in the order they are transmitted, starting with the MSB of the frame type (FT) field and ending with the LSB of the last field in the first PHY_H information bits of the PHY Frame. The E_HCS is present only for extended PHY header frames and shall be computed over all the fields of the second set of PHY_H PHY-frame header information bits in the order they are transmitted, starting with the MSB of the first field in the second set of PHY_H information bits of the PHY-frame header and ending with the LSB of the last field in the second set of PHY_H information bits.

The HCS and E_HCS shall be computed using the following generator polynomial of degree 16:

$$G(x) = x^{16} + x^{12} + x^5 + 1.$$

The value of the HCS and E_HCS shall be the remainder after the contents (treated as a polynomial where the first input bit is associated with the highest degree, X^{PHY_H-17} , where PHY_H is the number of header information length in bits -bits over which the HCS or E_HCS is computed, and the last input bit is associated with X^0) of the calculation fields is multiplied by x^{16} and then divided by $G(x)$.

The HCS and E_HCS fields shall be transmitted starting with the coefficient of the highest order term (MSB).

7.1.2.3.2.2 ACK PHY-frame type specific fields (working text)

Table 7-11.1 lists the ACK PHY frame type specific fields.

Table 7-11.1/G.hn – ACK PHY Frame Type Specific Fields

Field	Size in bits
FAACK	3
FLCTRLT	1
FLCTRL	3
LSSNP	1
RXRST_DATA	1
RXRST_MNGMT	1
ACKI/LSSN	16
ACKI	64
RXRST_DATA	1
RXRST_MNGMT	1
Pad	padding until PHY _H
ACKI ^[1]	136
Pad ^[1]	padding until 2 x PHY _H
Notes [1] These fields are present for the extended PHY-frame header only.	

<<End Text - G.9960 Amendment I>>

3. Summary:

This contribution is intended to be discussed at the G.hn meeting to be held in Xi'an China – 27 – 31 July 2009.

This contribution proposes changes to working text.

Specifically proposed are the following new agreements:

5.0.1.2.1.0.2 .1.5		New	should the PHY frame header number of information bits be optionally expandable to 2 x PHYH bits as described in contribution 09XC-119?	09XC-119
5.0.1.2.1.0.2 .1.6		New	should the text proposed in §2 of 09XC-119 that adds fields and description for supporting extended PHY-frame headers be incorporated as a revision of working text for §7.1.2.3 “PHY-frame header” and the sub-clauses for §7.1.2.3 in G.9960 Amendment 1?	09XC-119

ITU-T Recommendation G.9960
Draft generation home Networking transceivers

Table of contents

8	Summary	4
9	Keywords	4
10	Introduction	4
11	1	Scope	4
12	2	References	4
13	3	Definitions.....	5
14	4	Abbreviations	9
15	5	HN architecture and reference models.....	10
16	5.1	HN architecture and topology	10
17	5.1.1	HN Domains.....	11
18	5.1.1.1	General rules of operation	11
19	5.1.1.2	Modes of operation	12
20	5.1.1.3	Relationship between domain and medium	14
21	5.1.2	Domain master functionality and node parameters.....	16
22	5.1.3	Global master function.....	17
23	5.1.4	Quality of service (QoS)	18
24	5.1.5	Security	19
25	5.1.6	Inter-domain bridging	20
26	5.1.6.1	End-to-end QoS for multi-domain connections	22
27	5.1.6.2	Security in multi-domain connections	22
28	5.1.7	Low power modes	22
29	5.2	Reference models	23
30	5.2.1	Protocol reference model of HN transceiver.....	23
31	5.2.2	Interfaces - functional description.....	25
32	5.2.2.1	A-interface.....	25
33	5.2.2.1.1	AIF_DATA.REQ	25
34	5.2.2.1.2	AIF_DATA.CNF	26
35	5.2.2.1.3	AIF_DATA.IND	26
36	5.2.2.1.4	AIF_CTRL.REQ	26
37	5.2.2.1.5	AIF_CTRL.CNF	27
38	5.2.2.1.6	AIF_CTRL.IND	27
39	5.2.2.2	Medium-Independent Interface (MII).....	27
40	5.2.2.3	Medium-dependent interface (MDI)	28
41	5.2.3	Functional model of an HN transceiver	28
42	6	Profiles	29
43	7	Physical layer specification.....	30
44	7.1	Media independent specification.....	30
45	7.1.1	Functional model of the PHY	30
46	7.1.2	Physical coding sub-layer (PCS).....	31
47	7.1.2.1	PHY frame	31
48	7.1.2.2	MPDU mapping	32

49	7.1.2.3	PHY-frame header	32
50	7.1.2.3.1	Common part fields.....	33
51	7.1.2.3.1.4	Destination ID (DID)	34
52	7.1.2.3.1.5	Multicast Indication (MI).....	34
53	7.1.2.3.1.7	Duration.....	34
54	7.1.2.3.2	Variable part specific fields.....	35
55	7.1.3	Physical medium attachment (PMA) sub-layer	42
56	7.1.3.1	Scrambling	43
57	7.1.3.2	FEC encoding.....	43
58	7.1.3.2.1	Encoder	45
59	7.1.3.2.2	FEC encoding parameters	47
60	7.1.3.3	Payload encoding	47
61	7.1.3.3.1	Payload repetition encoding.....	48
62	7.1.3.4	Header encoder.....	51
63	7.1.3.5	Segmentation into symbol frames	51
64	7.1.3.5.1	Payload segmentation.....	52
65	7.1.3.5.2	Header segmentation	52
66	7.1.3.6	Probe frame	52
67	7.1.4	Physical medium dependent (PMD) sub-layer	52
68	7.1.4.1	Sub-carrier spacing and logical indexing	53
69	7.1.4.2	Tone Mapper	54
70	7.1.4.2.1	Summary of sub-carrier types	54
71	7.1.4.2.5	Special mappings	57
72	7.1.4.2.6	Modulation of unloaded sub-carriers	57
73	7.1.4.3	Constellation Encoder	58
74	7.1.4.3.1	Constellation mapping	58
75	7.1.4.3.2	Constellation point scaling.....	62
76	7.1.4.3.3	Constellation Scrambler.....	63
77	7.1.4.4	OFDM modulator.....	64
78	7.1.4.4.1	IDFT	65
79	7.1.4.4.2	Cyclic extension and OFDM symbol.....	65
80	7.1.4.4.3	Symbol Timing.....	66
81	7.1.4.4.4	Windowing, overlap and add	67
82	7.1.4.4.5	Frequency up-shift	68
83	7.1.4.4.6	Output signal	68
84	7.1.4.5	Preamble.....	69
85	7.1.4.5.1	General preamble structure	69
86	7.1.4.5.2	Preamble generation.....	70
87	7.1.4.6	PMD control parameters	72
88	7.1.4.7	Symbol boost.....	73
89	7.1.5	Transmit PSD Mask	74
90	7.1.5.1	Sub-carrier masking (notching).....	74
91	7.1.5.2	PSD ceiling.....	74
92	7.1.5.3	PSD shaping.....	74
93	7.1.5.4	Notching of International Amateur radio bands.....	75
94	7.2	Media dependent specification.....	75
95	7.2.1	Physical layer specification over phone lines	75
96	7.2.1.1	Control parameters	75
97	7.2.1.2	Preamble.....	76
98	7.2.1.2.1	Default preamble structure.....	76

99	7.2.1.3	PSD mask specifications	77
100	7.2.2	Physical layer specification over power lines	79
101	7.2.2.1	Control parameters	79
102	7.2.2.2	Preamble.....	80
103	7.2.2.2.1	Default preamble structure	80
104	7.2.2.3	PSD mask specifications	81
105	7.2.3	Physical layer specification over coax	83
106	7.2.3.1	Control parameters	83
107	7.2.3.2	Preamble.....	84
108	7.2.3.2.1	Default preamble structure	84
109	7.2.3.3	PSD mask specifications	85
110	7.2.3.4	Coexistence on coax.....	89
111	7.2.4	Transmitter EVM Requirements	89
112	Annex A – Regional requirements for North America		90
113	Annex C – Regional requirements for Japan		91
114	C.1	Scope	91
115	C.2	Media dependent specification.....	91
116	C.2.1	Physical layer specification over phonelines	91
117	C.2.2	Physical layer specification over powerlines	91
118	C.2.2.1	Frequency use for powerlines	91
119	C.2.3	Physical layer specification over coax	91
120	C.2.3.1	Bandplan	91
121	C.2.3.2	Transmitter EVM Requirements for RF coax	92
122	Annex D – International Amateur radio bands		93
123	Appendix I: Consideration of Domains Comprising Multiple Wire Classes.....		94
124	Appendix II: Examples of HN topologies.....		96
125	Appendix III: Spectral usage.....		101
126	III.1	Scope	101
127	III.2	Spectral usage in Japan	101
128	III.2.1	Frequency allocation for coax	101
129	III.2.1.1	Terrestrial broadcast signal mapped to coax cable.....	101
130	III.2.1.2	Broadcast Satellite (BS) and Communication Satellite (CS) signal	
131		mapped to coax cable	102
132	III.2.1.3	CATV services on coax cable	103
133	III.2.2	Frequency allocation for phone line.....	104
134	III.2.3	Frequency allocation for power line	104
135	III.2.4	Bibliography	104
136	Appendix IV - Priority Mapping.....		106
137			

138 ITU-T Draft Recommendation G.9960

139 Next generation wireline based home networking transceivers – Foundation

140 **Summary**

141 This Foundation Recommendation specifies basic characteristics of next generation home
142 networking transceivers capable of operating over premises wiring including inside telephone
143 wiring, coaxial cable, and power line wiring, and combinations of these, at data rates up to 1
144 gigabit/second. The specification includes a description of the home network architecture and
145 reference models along with major aspects of the transceiver physical layer specification. A future
146 version of this Recommendation will include the data link layer and regional Annexes to complete
147 the transceiver specification.

148 **Keywords**

149 <Optional>

150 **Introduction**

151 This Foundation Recommendation specifies basic characteristics of home networking transceivers
152 capable of operating over premises wiring including inside telephone wiring, coaxial cable, and
153 power line wiring, and combinations of these. The transceivers defined by this specification provide
154 the data rate and quality of service necessary for triple-play residential services as well as business-
155 type services delivered over xDSL, PON, or other access technology. The transceivers use OFDM
156 type of modulation and are designed to provide EMC and spectral compatibility of home
157 networking transmission with VDSL2 and other types of DSL used to access the home.

158 **1 Scope**

159 This Foundation Recommendation specifies basic characteristics of home networking transceivers
160 designed for the transmission of data over in-premises networks operating over phoneline,
161 powerline or coax.

162 Specifically, this Recommendation defines:

- 163 • the home network architecture and reference models;
- 164 • major aspects of the physical layer specification (PCS, PMA and PMD), including PSD
165 limit masks;

166 These devices are intended to be compatible with other devices sharing the in-premises wiring.

167 Additionally, the Recommendation provides for spectrum notching for compatibility with Amateur
168 radio services.

169 A future version of this Recommendation will specify the data link layer, including APC, LLC and
170 MAC.

171 **2 References**

172 The following ITU-T Recommendations and other references contain provisions, which, through
173 reference in this text, constitute provisions of this Recommendation. At the time of publication, the
174 editions indicated were valid. All Recommendations and other references are subject to revision;
175 users of this Recommendation are therefore encouraged to investigate the possibility of applying the

176 most recent edition of the Recommendations and other references listed below. A list of the
177 currently valid ITU-T Recommendations is regularly published.
178 The reference to a document within this Recommendation does not give it, as a stand-alone
179 document, the status of a Recommendation.
180 [1] ITU-T Recommendation X.1035 (2007), *Password-authenticated key exchange (PAK) protocol*
181

182 3 Definitions

183 This Recommendation defines the following terms:

184 **Alien domain:** any group of non-HN nodes connected to the same medium or operating in a close
185 proximity. Alien domains can interfere with HN domains. The bridging function to an alien domain,
186 as well as coordination with an alien domain to avoid mutual interference is beyond the scope of
187 G.9960.

188 NOTE – HN nodes see interference from an alien domain as a generic external
189 noise and deals with it accordingly. An example of an alien domain could be the
190 in-home part of the access network or any non-HN home network operating over
191 the same wires or other type of media.

192 **Bridge to alien domain/network:** an application device implementing an L2 or L3 bridging
193 function to interconnect an HN node to a node of an alien domain (or alien network). Bridging to
194 alien domains/networks is beyond the scope of G.9960.

195 **Broadcast:** a type of communication where a node sends the same packet simultaneously to all
196 other nodes in the network or in the domain (domain broadcast).

197 **Centralized (CTR):** a type of communication within a domain in which an HN node can
198 communicate with other HN nodes through a relay node. The relay node receives a signal from the
199 HN node and further forwards it to the addressee nodes.

200 **Channel:** a transmission path between G.9960 nodes. One channel is considered to be one
201 transmission path. Logically a channel is an instance of communications medium used for the
202 purpose of passing data between two or more nodes.

203 **Client:** an application entity distinguished in the network by its unique address (e.g., MAC
204 address).

205 **Client association Table (CAT):** a table that associates a Client address with a G.9960
206 node through which this client can be reached from within the domain.

207 **Coding overhead:** a part of the overhead used to carry the coding redundancy (such as redundancy
208 bits of error correction coding or CRC).

209 **Crosstalk:** disturbance (including packet collision) introduced by or due to operation of alien
210 networks or other (independent) G.9960 networks.

211 **Data:** bits or bytes transported over the medium or via a reference point that individually convey
212 information. Data includes both user (application) data and any other auxiliary information
213 (overhead, including control, management, etc.). Data does not include bits or bytes that, by
214 themselves, do not convey any information, such as frame alignment bits or preamble.

215 **Data packet (packet):** an ordered group of bits or bytes with start and stop delimiters.

- 216 **Data rate:** the average number of data elements (bits, bytes, packets or frames) communicated
217 (transmitted) in a unit of time. Depending on the data element, data bit rate, data byte rate, data
218 packet rate, and symbol frame rate may be used. The usual unit of time for data rate is 1 second.
- 219 **Device ID:** a unique identifier allocated to a G.9960 node operating in the network by the domain
220 master after registration.
- 221 **Domain:** a part of a home network comprising all those G.9960 nodes that can communicate,
222 interfere, or both with each other directly at the physical layer. There is no interference between
223 different domains of the same home network (except crosstalk between closely routed wires).
- 224 **Domain access point:** The unique relay node in centralized mode (CM) through which all nodes
225 communicate.
- 226 **Domain ID:** a unique identifier of a G.9960 domain.
- 227 **Domain master (DM):** node of a domain managing (coordinating) all other nodes of the same
228 domain (i.e., assign bandwidth resources and manage priorities). Only one active domain master is
229 allowed in a domain, and all nodes within a domain are managed (coordinated) by a single domain
230 master. If a domain master fails, another node of the same domain, capable of operating as a domain
231 master, should pick up the function of the domain master.
- 232 **Flow:** a uni-directional stream of data between two G.9960 nodes related to a specific application
233 and/or characterized by a specific set of performance and traffic parameters (e.g. QoS parameters,
234 latency, jitter, PLR).
- 235 **Flow ID:** a unique identifier allocated to a flow within a domain.
- 236 **Global master (GM):** a function that provides coordination between different HN domains (such
237 as communication resources, priority setting, policies of domain masters, and crosstalk mitigation).
238 A GM may also convey management functions initiated by the remote management system (e.g.
239 TR-69) to support broadband access. The GM is an optional function.
- 240 **Guard interval:** the time interval intended to mitigate corruption of data carried by the symbol due
241 to ISI from the preceding symbols. In OFDM, the guard interval is implemented as a cyclic
242 extension (cyclic prefix and/or cyclic suffix).
- 243 **Hidden node:** a node that can't communicate directly with some other nodes within a domain.
- 244 NOTE – A hidden node may be able to communicate with another node or with a
245 domain master using a relay node. A node that is hidden from a domain master
246 uses a relay node as a proxy to communicate with the domain master.
- 247 **Inter-domain bridge:** a bridging function above the physical layer to interconnect HN nodes of
248 two different HN domains.
- 249 **Jitter:** a measure of the latency variation above and below of the mean latency value. The
250 maximum jitter is defined as the maximum latency variation above and below the mean latency
251 value.
- 252 **Latency:** a measure of the delay from the instant when the last bit of a packet has been transmitted
253 through the assigned reference point of the transmitter protocol stack to the instant when a whole
254 packet reaches the assigned reference point of receiver protocol stack. Mean and maximum latency
255 estimations are assumed to be calculated on the 99th percentile of all latency measurements. If
256 retransmission is set for a specific flow, retransmission time is a part of latency for the protocol
257 reference points above MAC.
- 258 **Line data rate:** the data rate at the MDI reference point of the transceiver reference model. This is
259 the net data rate plus the overhead rate.

- 260 **Logical (functional) interface:** an interface in which the semantic, syntactic, and symbolic
261 attributes of information flows are defined. Logical interfaces do not define the physical properties
262 of signals used to represent the information. It is defined by a set of primitives.
- 263 **Management overhead:** a part of the overhead used for management purposes (such as network
264 discovery, channel estimation, acknowledge, establishing and tearing the flow).
- 265 **Medium:** a wire-line facility, of a single wire class, allowing physical connection between network
266 nodes (see Appendix I for medium composed of multiple wire classes). Nodes connected to the
267 same medium may communicate on the physical layer, and may interfere with each other unless
268 they use orthogonal signals (e.g., different frequency bands).
- 269 **Multicast:** a type of communication when a node sends the same packet simultaneously to one or
270 more other nodes in the network (the addresses could be both inside and outside the domain).
- 271 **Net data rate:** the data rate available at the A-interface of the transceiver reference model.
- 272 **Node (network node):** any home network device that contains a transceiver. An HN node is any
273 network device that contains a G.9960 transceiver.
- 274 **Operation modes of a domain:**
- 275 - **peer-to-peer mode (PM):** a mode of domain operation in which all HN nodes use only PP
276 type of communication with other nodes (without relay nodes). In peer-to-peer mode, no
277 relay nodes are allowed.
- 278 - **centralized mode (CM):** a mode of domain operation in which all HN nodes use CTR
279 type of communication with a single relay node. In centralized mode, only one relay node is
280 allowed and it is known as the domain access point (DAP).
- 281 NOTE – A DAP is likely to serve also as a Domain Master
- 282 - **unified mode (UM):** a mode of domain operation in which all nodes within a domain
283 communicate using PP or CTR type of communication, as necessary, while some of the
284 relay nodes may have additional functionalities. Unified mode can be used to support hidden
285 nodes. In unified mode, more than one relay node is allowed.
- 286 NOTE – In UM, there is no domain access point defined.
- 287 **Overhead rate:** a part of the line data rate used to support network operation. It includes
288 transmission overhead, management overhead, and coding overhead.
- 289 **Packet error ratio (PER):** a ratio of the number of errored packets received to the total number of
290 received packets. The PER can be used for the total stream of packets (aggregated PER) and for any
291 of its tributary packet flows (PER per flow).
- 292 **Packet loss ratio (PLR):** a ratio of the number of lost packets to the total number of received
293 packets. The PLR can be used for the total stream of packets (aggregated PLR) and for any of its
294 tributary packet flows (PLR per flow).
- 295 **Passband:** the portion of the frequency spectrum that is allowed to be used for transmission. The
296 passband may consist of multiple, disjoint portions of the frequency spectrum.
- 297 **Peer-to-peer (PP):** a type of communication within a domain in which direct signal traffic is
298 established between HN nodes with no relay nodes.
- 299 **Physical interface:** an interface defined in terms of physical properties of the signals used to
300 represent the information transfer. A physical interface is defined by signal parameters like power
301 (power spectrum density), timing, and connector type.

302 **Primitives:** basic measures of quantities obtained locally or reported by other nodes of the domain.
303 Performance primitives are basic measurements of performance-related quantities, categorized as
304 events, anomalies and defects. Primitives may also be basic measures of other quantities (e.g., ac or
305 battery power).

306 **Priority:** a value assigned to the specific packet(s) that determines the relative importance of
307 transmitting packet(s) during the upcoming opportunity to use the medium.

308 **Quality of service (QoS):** a set of quality requirements on the communications in the network.
309 Support of QoS refers to mechanisms that can provide different priority to different flows, or can
310 guarantee a measurable level of performance to a flow based on a set of QoS parameters.

311 **Reference point:** a location in a signal flow, either logical or physical, that provides a common
312 point for observation and or measurement of the signal flow.

313 **Registration:** the process used by a G.9960 node to join the domain.

314 **Relay node:** an HN node acting as an intermediary node, through which other nodes of the same
315 domain can pass their signal traffic (data, control, or management) in either direction of
316 transmission.

317 **Residential Gateway:** a device providing, among other functions, bridging between the access
318 network and the home network. Residential gateways are out of scope of G.9960.

319 **Stopband:** the portion of the frequency spectrum that is not allowed for transmission.

320 **Sub-carrier (OFDM sub-carrier):** the center frequency of each OFDM sub-channel onto which
321 bits may be modulated for transmission over the sub-channel.

322 **Sub-carrier spacing:** the difference between frequencies of any two adjacent OFDM sub-carriers.

323 **Sub-channel (OFDM sub-channel):** a fundamental element of OFDM modulation technology.
324 The OFDM modulator partitions the channel bandwidth into a set of parallel sub-channels.

325 **Symbol (OFDM symbol):** a fixed time-unit of an OFDM signal carrying one or more bits of data.
326 An OFDM symbol consists of multiple sine-wave signals or sub-carriers, each modulated by certain
327 number of data bits and transmitted during the fixed time called symbol period.

328 **Symbol frame:** A frame composed of bits of a single OFDM symbol period. Symbol frames are
329 exchanged over the δ -reference point between the PMA and PMD sub-layers of the PHY.

330 **Symbol rate:** the rate, in symbols per second, at which OFDM symbols are transmitted by a node
331 onto a medium. Symbol rate is calculated only for time periods of continuous transmission.

332 **Throughput (node):** The amount of data transferred from the A-interface of a source node to the
333 A-interface of a destination node over some time interval, expressed as the number of bits per
334 second.

335 **Transmission overhead:** a part of the overhead used to support transmission over the line (e.g.,
336 samples of cyclic prefix, inter-packet gaps, and silent periods).

337 **Unicast:** a type of communication when a node sends the packet to another single node (inside or
338 outside of the domain).

339 **Wire class:** one of the classes of wire, having the same general characteristics: coaxial cable, home
340 electrical power wire, phone line wire and Category 5 cable.

341

342

343 **4 Abbreviations**

344 This Recommendation uses the following abbreviations:

345	AE	application entity
346	AN	access network
347	APC	application protocol convergence
348	CM	centralized mode of domain operation
349	CoS	class of service
350	CTR	centralized type of communication
351	DAP	domain access point
352	DLL	data link layer
353	DM	domain master
354	DSL	digital subscriber line
355	GM	global master
356	HN	home network comprising exclusively G.9960 network devices
357	LDPC-BC	low-density parity-check block-codes
358	LLC	logical link control
359	MAC	media access control
360	MAP	media access plan
361	MDI	medium-dependent interface
362	MII	media-independent interface
363	OFDM	orthogonal frequency division multiplexing
364	PCS	physical coding sub-layer
365	PM	peer-to-peer mode of domain operation
366	PMA	physical medium attachment
367	PMD	physical medium dependent
368	PON	passive optical network
369	PP	peer-to-peer type of communication
370	QC-LDPC-BC	Quasi-cyclic low-density parity-check block-code
371	QoS	quality of service
372	RG	residential gateway
373	UM	unified mode of domain operation

374

375 **5 HN architecture and reference models**

376 **5.1 HN architecture and topology**

377 A generic structure of HN is presented in Figure 5-1. The model includes one or more domains,
378 inter-domain bridges, and bridges to alien domains of a home network (e.g., WiFi, ethernet, USB),
379 and a bridge to the access network (e.g., DSL, PON, cable). The global master is an optional
380 function that provides coordination between different HN domains (such as channel resources,
381 priority setting, domain operational characteristics), and may convey the relevant functions initiated
382 by the remote management system (e.g., Broadband Forum TR-069) to support broadband access.
383 Bridges to alien domains are beyond the scope of G.9960.

384 NOTE 1 – It is not necessary that all inter-domain bridges presented in Figure 5-1
385 be used. Depending on the application, domains could be daisy-chained, or star-
386 connected, or could use another connection topology. Multi-route connections
387 between domains are not allowed.

388 NOTE 2 – Implementations of some nodes, e.g., residential gateway (RG), can
389 include inter-domain bridges allowing connection of the RG to more than one
390 domain (more than one medium).

391

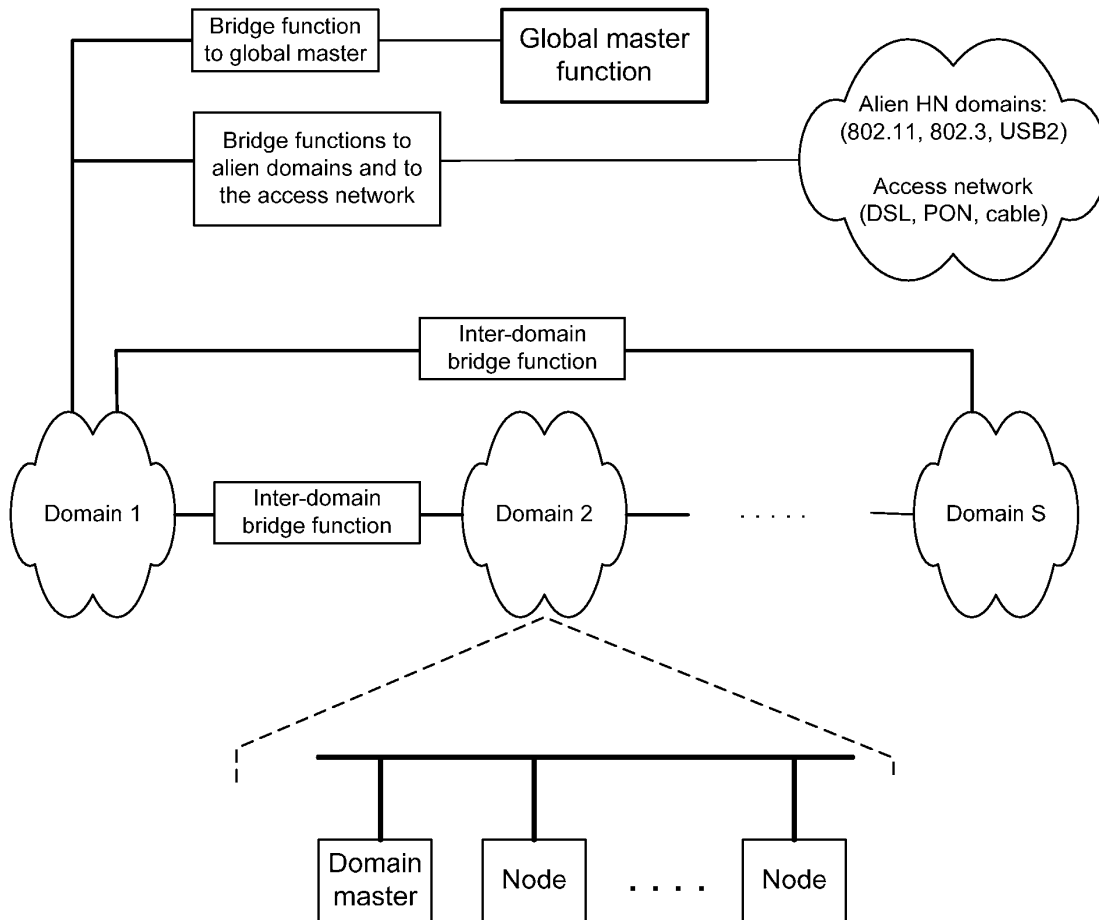

392
393

394 **Figure 5-1/G.9960 – G.9960 architecture reference model**

395 A domain contains HN nodes connected to the same medium, where one node is acting as a domain
396 master. Nodes of the same domain communicate via the medium over which the domain is
397 established. Nodes connected to different domains communicate via inter-domain bridges (e.g. L2
398 or L3 bridging, see §5.1.6).

399 A domain shall be capable of supporting at least 32 registered nodes and may optionally support up
400 to 250 registered nodes. Each node shall be capable of supporting simultaneous communication
401 sessions with at least 8 other nodes using dedicated transmission profiles (runtime BATs), different
402 from the pre-defined transmission profiles described in §7.1.4.2.2.1.

403 The scope of G.9960 is limited to transceivers of all HN nodes capable of operating as a regular
404 node or a domain master, or as a domain access point (DAP) or as a relay node of any HN domain.
405 Other parts of HN, including inter-domain bridges, RG (as a bridge to the access network), and
406 bridges to alien domains, are beyond the scope of G.9960; however G.9960 defines all necessary
407 hooks to support their functionality and exchange of relevant information.

408 The domain master considers bridges to alien domains as regular clients of an HN node with certain
409 bandwidth requirements, while it considers inter-domain bridges as regular clients whose interfaces
410 (see §5.1.6) comply with requirements implied by this Recommendation.

411 **5.1.1 HN Domains**

412 **5.1.1.1 General rules of operation**

413 A domain as depicted in Figure 5-1 may include the following types of nodes: regular nodes, relay
414 nodes, a domain master, and a DAP.

415 The function of the domain master is to assign and coordinate resources (bandwidth and priorities)
416 of all nodes in its domain. The following rules apply for any domain:

- 417 1. There shall be one and only one active domain master per domain. In case an active domain
418 master is not assigned, fails, or is switched off, a domain master selection procedure is initiated
419 to assign a new active domain master. This procedure is for further study.
- 420 2. Nodes of the same HN network that can communicate and interfere with each other directly at
421 the physical layer (except crosstalk between closely routed wires) shall be assigned to the same
422 domain.
- 423 3. All HN nodes within a domain shall be capable of operating in PP type of communication and
424 CTR type of communication (the CTR is considered as a subset of PP, where the first
425 destination address for the node is a relay node). For both PP and CTR types of communication,
426 bandwidth resources and priorities of all nodes within the domain are managed by the domain
427 master.
- 428 4. More than one domain may be established over the same medium, for example, by using
429 orthogonal signals over different frequency bands.
- 430 5. A G.9960 network may include one or more domains.
- 431 6. Domains from independent G.9960 networks established over the same medium may interfere
432 with each other (e.g., if they use the same frequency band). Coordination between G.9960
433 domains of independent networks sharing a common medium is for further study.
- 434 7. G.9960 nodes are not required to be domain master capable. That is, some G.9960 nodes may
435 not support the functionality necessary to become a domain master.
- 436 8. All nodes in a domain shall be managed by a single domain master.

- 437 9. The HN network shall have a unique network name. All domains of the same HN network shall
438 use this network name.
- 439 10. The domain master shall assign a device ID to a node during the node's registration process.
- 440 11. All nodes within the same domain shall use the same domain ID.
- 441 12. A node shall not pass via its A-interface packets contained in PHY frames sourced by other
442 domains (having a different domain ID value than the one that the node is associated with). A
443 node shall be capable of detecting existence of a neighbouring domain when receiving its PHY
444 frame (having a different domain ID value than the one that the node is associated with).

445

446 NOTE – The method of determining a domain ID for assignment is for further
447 study.

448

449 5.1.1.2 Modes of operation

450 A domain can operate in one of 3 modes: peer-to-peer mode (PM), centralized mode (CM), and
451 unified mode (UM). Different domains within the HN can use different modes of operation, i.e. PM,
452 CM, or UM. Examples of domains in different operation modes are presented in Appendix II.

453 Broadcast and multicast shall be supported in any domain, independently of its operation mode
454 (PM, CM or UM).

455 In PM, only PP type of communication shall be used in the domain. Thus, direct signal traffic is
456 established between two communicating nodes. Figure 5-2 shows PP communication between
457 nodes A and B. Packets addressed to nodes outside the domain are sent to the node associated with
458 the inter-domain bridge (node C in Figure 5-2).

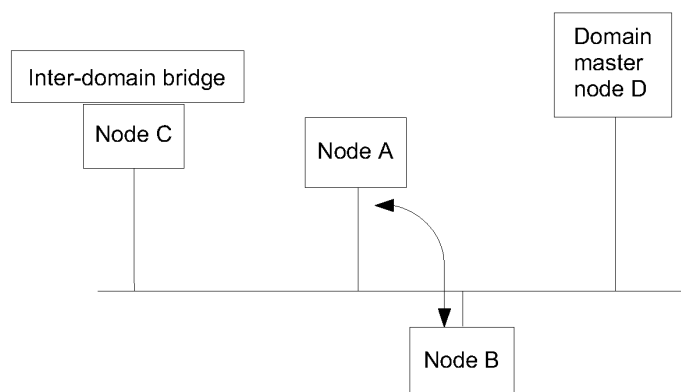

459

460 **Figure 5-2/G.9960 – Domain operating in peer-to-peer mode (PM)**

461 In CM, only CTR type of communication shall be used. Thus, any node of the domain can
462 communicate with another node only through the DAP. The DAP receives signals from all nodes of
463 the domain and further forwards them to the corresponding addressee nodes. Packets addressed to

464 nodes outside the domain are forwarded by the DAP to the node associated with the inter-domain
465 bridge (node C in Figure 5-3). Usually, but not necessarily, the DAP also serves as a domain master
466 (Figure 5-3).
467

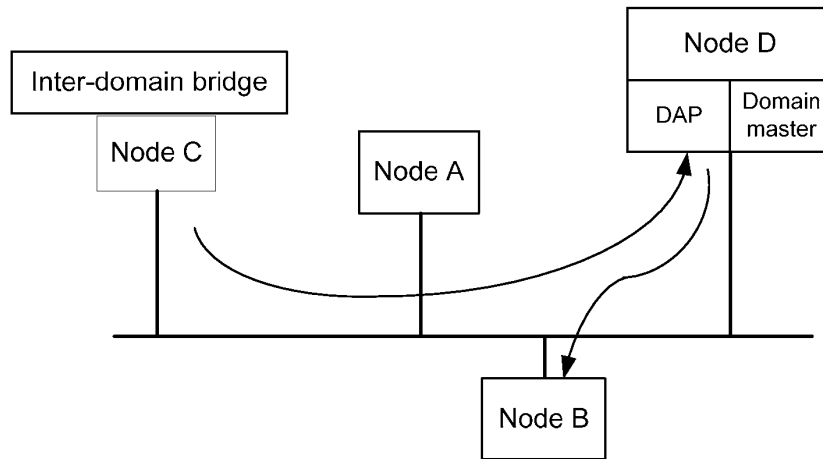

468

469 **Figure 5-3/G.9960 – Domain operating in centralized mode (CM)**

470 In case of DAP failure, no communication between nodes in the domain is allowed.

471 In UM, a hidden node in a domain can communicate with another node through a relay node as
472 shown in Figure 5-4. In the example, two nodes within the same domain (Node C and Node H) that
473 are hidden from each other communicate with each other via the relay node (Node A). Both nodes
474 are managed by the domain master (Node D) and can communicate directly with all other nodes.
475 Packets addressed to nodes outside the domain are sent to the node associated with the inter-domain
476 bridge (node C in Figure 5-4).

477

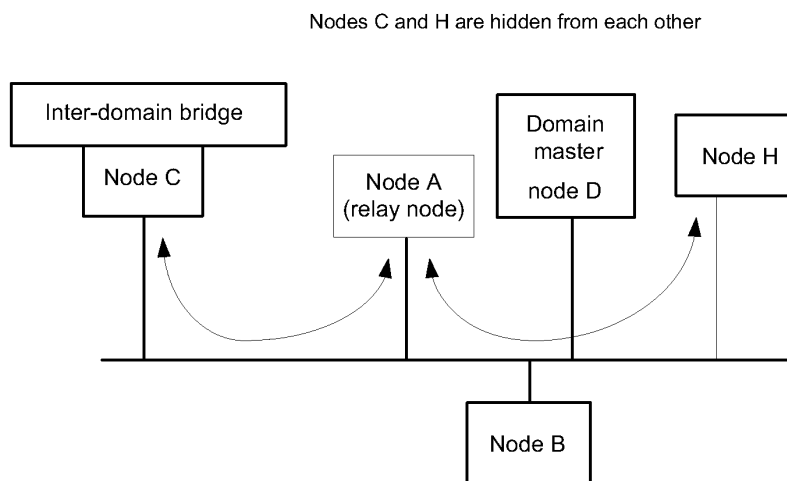

478

479 **Figure 5-4/G.9960 – A domain operating in Unified mode (UM) containing hidden nodes**

480 **5.1.1.3 Relationship between domain and medium**

481 Figure 5-5 shows several examples of the relationships between domain, medium and wire class.
482 Note that in Figure 5-5, each of the domains is shown to be associated with a single medium. This
483 represents the focus of the HN network; domains optimized to operate on a single wire class with
484 multiple domains interconnected via inter-domain bridges. Figure 5-5 (A) shows an example
485 network segment comprising three different media: coax, phone line and power line. A single
486 domain exists on each medium and the domains are separated by inter-domain bridges. Figure 5-5
487 (B) shows another example network segment comprising phone line and power line mediums. In
488 this case, the phone line medium comprises two segments of phone wire that are joined by splicing
489 or at a connector. These two phone line segments are of a single wire class and therefore are a
490 single medium. As shown in Figure 5-5 (A), there is a single domain on each medium and the
491 domains are separated by inter-domain bridges. Figure 5-5 (C) shows the example network
492 segment from Figure 5-5 (A), but also demonstrates the potential for having multiple domains on a
493 medium. In Figure 5-5 (C), the phone line medium carries three domains and the power line
494 medium carries two domains. The multiple domains on each individual medium must have
495 orthogonal signaling to avoid interference. For example, on the power line, domain C5 must have
496 signaling that is orthogonal to signaling on domain C6. These domains communicate via inter-
497 domain bridges that are not shown in the figure. Refer to Figure II-3 for an alternative
498 representation of multiple domains on a single medium.

499 It is possible to interconnect wire classes and operate them under a single domain. This special
500 application of HN is described in Appendix I. However, it is expected that such scenarios would
501 occur very infrequently and such practices will be avoided if possible.

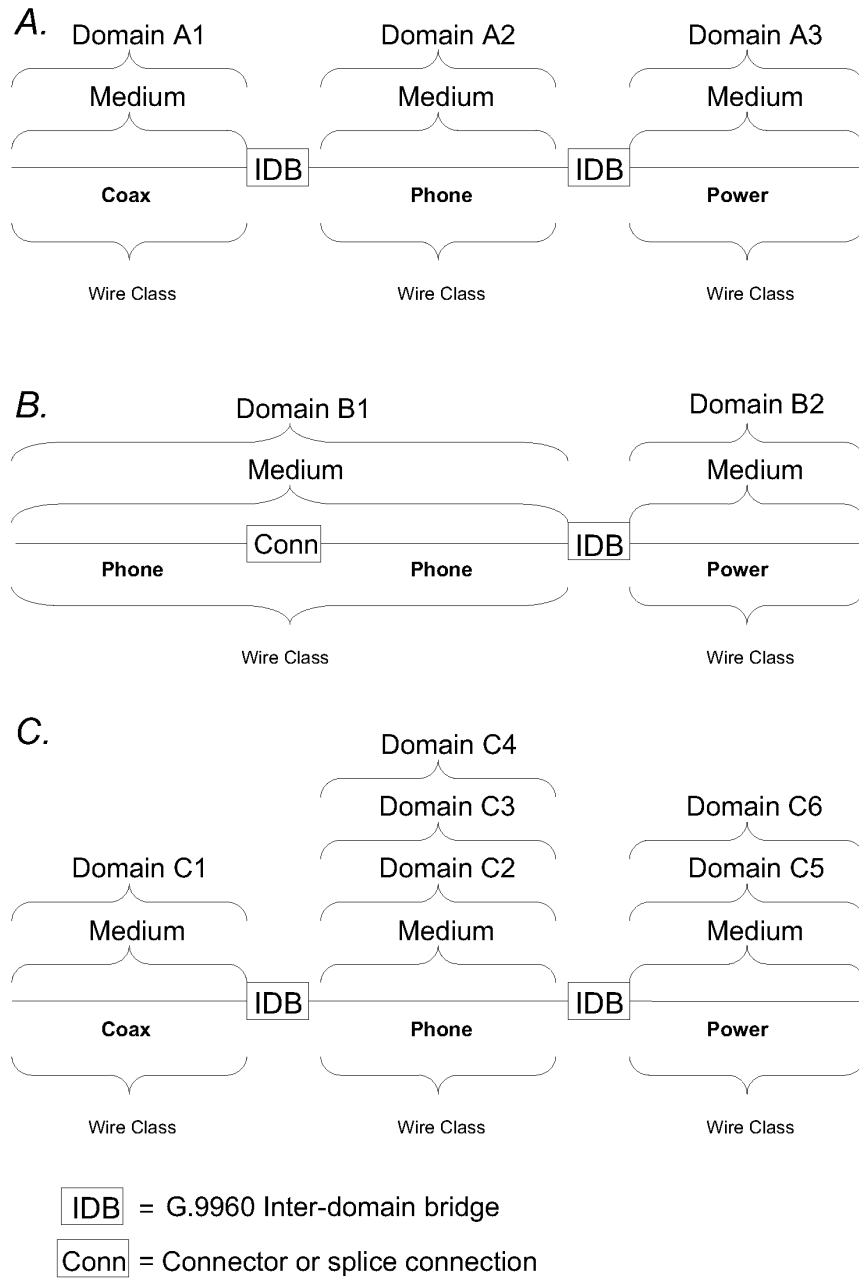

502

503

504

505

Figure 5-5/G.9960 – Relationships between domain, medium and wire class

506 **5.1.2 Domain master functionality and node parameters**

507 A domain master controls operation of the nodes in the domain. The main functions of a domain
508 master are summarized in Table 5-1.

509 **Table 5-1/G.9960 – Main Functions of the Domain Master**

Function	Description	
Indication of presence	Periodically communicates MAP to all nodes in the domain	
Admission control	Admits new nodes to the domain Limits the number of nodes in a domain Facilitates departure of nodes from the domain	
Determination of domain operation	Assigns mode of operation inside the domain (PM, CM, or UM) Supports hidden nodes by assigning MAP repeaters Supports synchronization of the MAC cycle to an external source (e.g., the AC line) Facilitates spectrum compatibility for the domain by assigning relevant limits on: - Frequency band - Maximum transmit power - PSD mask	
Bandwidth allocation and QoS support	Assigns media access rules to all nodes of the domain to facilitates support of QoS	
Security	Assists authentication and encryption keys management	
Monitor status of the domain	Collects statistics of domain operation: - List of nodes in the domain - Topology - Performance statistics (data rate, error count) - Statistics on neighboring domains	
Communication with the global master	Coordinates operation of the domain with other domains using the global master function	
Backup master assignment	Assigning of a backup domain master to take over the domain master role	

510

511 The main functions and capabilities of a regular node (end-node) are summarized in Table 5-2.

512

Table 5-2/G.9960 – Main Functions and capabilities of a regular node

Function	Description and Parameters	
Interpretation of the traffic specification	Receives and interprets the MAP	
Support of admission control protocol	Supports admission control protocol	
Support of operation modes of the domain	Supports the operation mode (PM, CM, or UM) Complies with spectrum compatibility settings for the domain by assigning relevant limits on: - Frequency band - Maximum transmit power - PSD mask	
Support of media access rules	Accesses media using media access rules coordinated with the domain master	
Support of security	Supports authentication and encryption key management procedures	
Collection and reporting of node information	Provides statistics about: - List of visible nodes - List of clients (CAT) - List of capabilities supported by the node - Performance statistics (data rate, error count, time stamps) - Statistics on detected neighboring networks	
Request of bandwidth allocation	- Creates flows - Requests bandwidth allocations from the domain master in order to meet QoS requirements of flows	
Support of retransmissions	Provides acknowledgment and retransmission of data units that were received with error	
Support of extended capabilities	- Domain Master - Domain Access Point (DAP) - Data Relaying - MAP Repeating - Domain master selection procedure	

513 **5.1.3 Global master function**

514 The global master (GM) function, if implemented, interacts with G.9960 domains and coordinates
515 their operation by exchanging relevant information with domain masters via the logical M-interface
516 as shown in Figure 5-6.

517

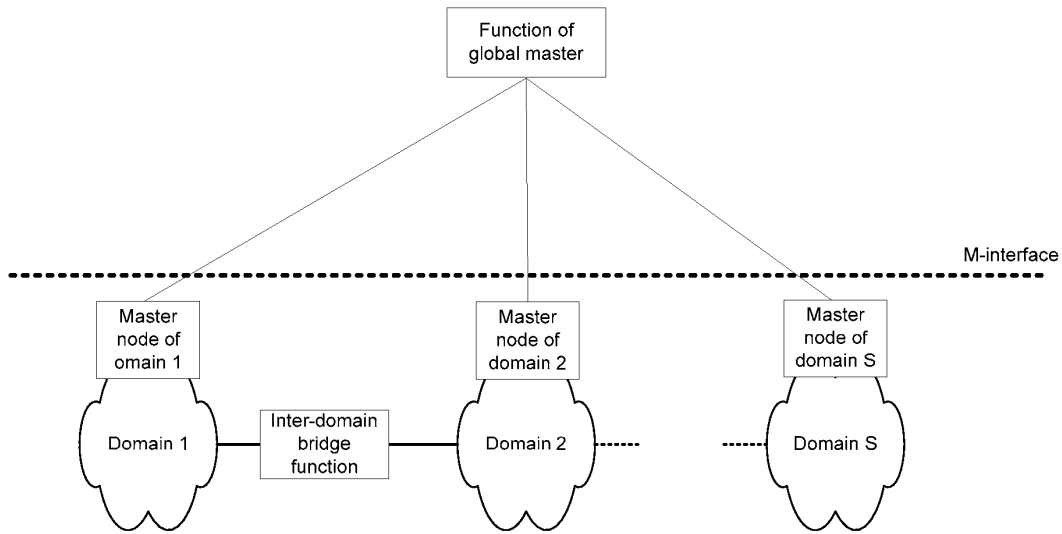

518

519

Figure 5-6/G.9960 – Functional model of GM

520 The following rules apply to the GM:

- 521 1. In a multi-domain network, the GM may coordinate some or all domains. For coordination, the
522 GM exchanges information with domain masters of all coordinated domains via the M-
523 interface. The GM may retrieve relevant domain-related data from domain masters and send
524 control signals and data for coordination between domains to domain masters.
- 525 2. The M-interface is functional; its physical implementation is vendor discretionary. In case a
526 domain master is replaced (e.g., as a result of a failure), the GM shall interface to the newly
527 selected domain master.
- 528 3. The Information exchange protocol between the GM and a domain master is unified for all
529 domains. To identify a specific domain for communication, the GM shall use the domain ID.

530 NOTE – The GM doesn't limit the number of domains in the network, although
531 the format of the domain ID shall fit the 4-bit field (DOD field in the PHY-frame
532 header – §7.1.2.3), which limits the potential management capability of the GM.

533 5.1.4 Quality of service (QoS)

534 Quality of service (QoS) is a measure of the quality of delivery of services in the network, placing
535 requirements on the transmission and queuing of network traffic. G.9960 supports two QoS
536 methods: Priority-based QoS and Parameter-based QoS.

537 The QoS requirements are supported between nodes inside the same domain and between nodes
538 connected to different domains if services communicated between nodes belong to different
539 domains. In the latter case, inter-domain bridges are expected to not compromise the QoS
540 requirements (such as latency).

541 For communication inside a domain, the G.9960 QoS mechanism operates per flow. Flows are set
542 up and torn down on a service basis. The type of service communicated by the flow determines the
543 QoS method over the flow and any relevant QoS parameters. Data packets belonging to a specific
544 flow are scheduled to be sent onto the media in accordance with the defined QoS method. The
545 G.9960 QoS method shall handle both constant and variable bit-rate traffic.

546 Priority-based QoS refers to a mechanism that provides different priorities for media access to
547 different flows. All HN transceivers shall support priority-based QoS. The number of supported
548 priority levels associated with the incoming packets (at A-interface) shall be 8 (denoted from 0 to
549 7).

550 With priority-based QoS, the G.9960 transceiver associates each flow with a certain priority queue,
551 based on priority or other priority-related parameters of incoming packets. The G.9960 priority-
552 based QoS method defines the order in which packets from each queue will be sent to the medium
553 and in which order packets will be processed (and possibly dropped), based solely on the priority
554 assigned to the queue. The number of supported priority queues may be less than 8 and depends on
555 the profile. The mapping between the priority of the flow and the associated priority queue shall be
556 as recommended by IEEE 802.1D-2004 for user priority to traffic class mappings, as shown in
557 Appendix IV.

558 Parameter-based QoS refers to a mechanism that provides specific performance metrics (QoS
559 parameters) for a given flow associated with the application (service), and resource allocation for
560 media access to meet these performance metrics. A set of these parameters may include, but is not
561 limited to, data throughput, latency, jitter, or PER.

562 With Parameter-based QoS, the G.9960 transceiver associates each flow with a set of QoS
563 parameters related to the particular service and with a certain queue. The G.9960 parameter-based
564 QoS method provides appropriate resources (e.g., bandwidth) necessary to communicate each flow
565 through the medium so that QoS parameters associated with this flow are met. It also determines the
566 order in which packets from each queue will be sent to the medium and in which order packets will
567 be processed (and possibly dropped) based on the knowledge of traffic parameters. The minimum
568 number of supported flows (queues) depends on the profile.

569

570 **5.1.5 Security**

571 G.9960 security is designed to address operation over shared media, such as power-line and coax
572 cable. Besides regular network admission procedures, which ensure that only permitted G.9960
573 nodes are allowed to join a G.9960 network via one of its domains, G.9960 defines point-to-point
574 security, allowing authentication of each pair of nodes prior to communication and unique
575 encryption keys for each pair of communicating nodes or per multicast group. This generally
576 improves security by building another layer of protection against an intruder that has broken
577 through the network admission control, and maintains full confidentiality for all communications
578 within the network. The latter suits G.9960 to be installed in public places (hotels, small businesses,
579 home offices), requiring at least the same grade of security and confidentiality as defined in the
580 most recent specification for wireless LAN (IEEE 802.11-2007).

581 G.9960 security provides the following main features:

- 582 • Encryption of all relevant data frames based on AES-128 and NIST recommendations
- 583 • Advanced authentication and secure admission of nodes into network domains, based on
584 ITU-T Recommendation X.1035 [1].
- 585 • Key management, including generation, secure communication, update, and termination of
586 encryption keys.
- 587 • High confidentiality and integrity of all transactions, including point-to-point authentication
588 and unique encryption keys.
- 589 • Support of secure operation with the presence of relay (proxy) nodes
- 590 • Allows simultaneous operation of distinct, separately secured networks on the same media.

591 Security procedures that are user-friendly may require the user to set a password for each node prior
592 to installation. The rest of the procedures necessary to establish and maintain security are facilitated
593 automatically by the security controller (SC) function, without involvement of the user.

594 Nodes that don't include an appropriate user interface may use a unique manufacturer-set password.

595 For applications in which reduced security is acceptable, the user may rely on a default password
596 provided by the manufacturer. Thus, no action from the user is required on installation, although
597 with a risk to connect the node to neighbouring G.9960 network.

598 Security and mutual confidentiality between clients associated with the same node is supposed to be
599 resolved at the higher layers of the client protocol stack and is beyond the scope of this
600 Recommendation.

601 5.1.6 Inter-domain bridging

602 The inter-domain bridge (IDB) function connects nodes of two G.9960 domains. In Figure 5-7,
603 application entities AE1 (service originator) and AE2 (service destination) are associated with
604 nodes A1 and B2 of two domains. The communication path between nodes A1 and B2 goes through
605 domain 1 and domain 2, and includes in-domain flows F1, F2 and the IDB function. Interfaces
606 between nodes B1, A2 and the IDB are regular client interfaces (A-interfaces, see §5.2.1).
607 Communication paths routed through more than two domains operate in the same way.

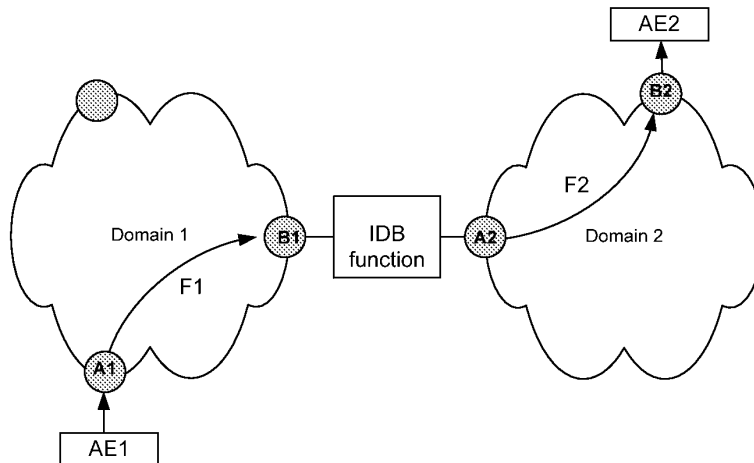

608
609

610 **Figure 5-7/G.9960 – Communication path between nodes of two different domains**

611 The protocol reference model for inter-domain communications shown in Figure 5-7 is presented in
612 Figure 5-8.

613

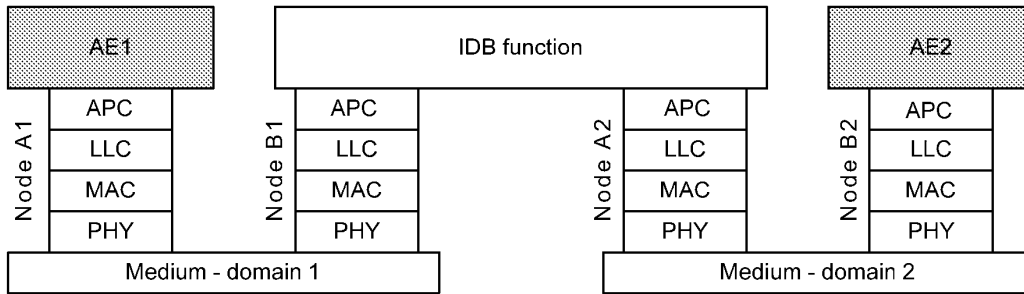

614

615

Figure 5-8/G.9960 – Protocol stack of inter-domain communication

616 In the case that the APC is implemented as an ethernet convergence sub-layer, the IDB function can
617 be implemented as a standard 802.1D transparent bridge.

618 One case of inter-domain bridging relates to implementation of multi-media devices, which are
619 equipped with more than one physical interface and, accordingly, can be connected to more than
620 one domain. A scenario describing a two-media device is presented in Figure 5-9. The IDB
621 connects the client associated with the device to both domains (via nodes B1 and A2), and provides
622 inter-domain connection (between nodes B1, A2, similar to one presented in Figure 5-7). The IDB
623 interfaces to nodes B1 and A2 as a regular AE, and also bridges the client AE to either or both of
624 these nodes.

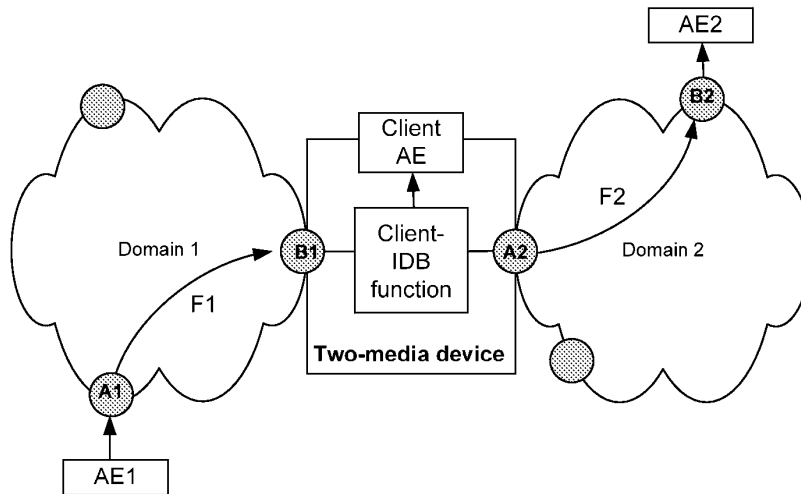

625

626

627

Figure 5-9/G.9960 – Example of communication with a two-media (domain) device

628 The protocol reference model corresponding to Figure 5-9 is presented in Figure 5-10. It assumes a
629 vendor-proprietary interface between the IDB and the client. However, a standard interface like
630 IEEE 802.3 can be used too.

631

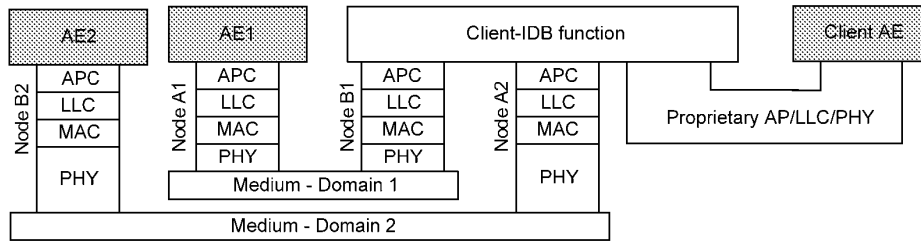

632

633

Figure 5-10/G.9960 – Protocol stack of inter-domain communication

634

635 5.1.6.1 End-to-end QoS for multi-domain connections

636 The end-to-end QoS requirements are defined by certain priority level (in case of priority-based
637 QoS), or by traffic parameters such as bit rate and latency (for parameterized QoS). See §5.1.4. In
638 both cases, to meet end-to-end requirements, certain tributary requirements shall be implied on in-
639 domain flows forming the connection and on IDB. In Figure 5-7, the end-to-end QoS requirements
640 for the service routed between nodes A1 and B2 determine tributary QoS requirements for flow F1,
641 carrying the service inside domain 1, and for flow F2, carrying the service inside domain 2, and for
642 the delay introduced by IDB.

643 In the case of prioritized QoS, the end-to-end QoS requirements can be met if the IDB conveys
644 priority requirements, so that the priority level applied to flow F1 in domain 1 corresponds with the
645 priority level applied to flow F2 in domain 2. In the same way, prioritized QoS shall be supported
646 for routes including more than 2 domains.

647 In case of parameterized QoS, the end-to-end QoS parameters shall be distributed between in-
648 domain flows and the IDBs. The rules of distribution of end-to-end QoS parameters between
649 multiple domains are for further study.

650 The IDB throughput shall be higher than the maximum throughput available in either of the
651 domains connected by the IDB. The delay introduced by the IDB should be minimized (the
652 maximum allowed values are for further study). The maximum number of IDBs in the path may be
653 limited for certain service types.

654 Other parameters of the IDB functionality are vendor discretionary.

655 5.1.6.2 Security in multi-domain connections

656 For a multi-domain G.9960 network, secure operation is achieved by setting all its domains to
657 secure mode. Communications between secure and non-secure domains shall not be allowed, unless
658 special security measures are provided by the IDB (on higher protocol levels). These measures are
659 beyond the scope of this Recommendation, same as security measures protecting IDB from outside
660 intrusion (i.e., when the intruder is one of the clients connected to the IDB). In the scope of this
661 Recommendation, IDB are supposed to be secure.

662

663 5.1.7 Low power modes

664

665 Three modes of operations are defined with the intention of reducing the total power consumption
666 in G.9960 based networks. When the electrical power for equipment connected to the home network
667 is switched on, operation modes for the equipment shall be one of the following:

- 668 • Full-power mode: This is the mode in which transmission up to maximum defined bit-rate is
669 possible. In this mode the power consumption is limited only by the defined PSDs.
- 670 • Low power mode(s): In these modes only a limited data transmission is running. The equipment
671 enters this mode when specific traffic parameters are met. The values of these parameters are for
672 further study.
- 673 • Idle mode: In this mode the equipment is switched on and connected physically to the network,
674 but no traffic at all is transmitted or received by the connected equipment. It should be possible
675 to initiate transmission both from the connected equipment and from other node (or client)
676 connected to the network. Transition from this power mode to full-power mode, when needed,
677 should take no more than 1 second.

678 During all power modes and transitions between them, the node shall maintain its original
679 DEVICE_ID.

680

681 **5.2 Reference models**

682 **5.2.1 Protocol reference model of HN transceiver**

683 The protocol reference model of an HN transceiver is presented in Figure 5-11. It includes three
684 main reference points: application interface (A-interface), media-independent interface (MII), and
685 medium-dependent interface (MDI). Two interim reference points, x1-interface and x2-interface,
686 are defined in the data link layer, and two other interim reference points, α -interface and δ -interface,
687 are defined in PHY layer, Figure 5-11.

688 The MDI is a physical interface defined in the terms of physical signals transmitted over a specific
689 medium (see §7.2) and mechanical connection to the medium.

690 The MII interface is both medium independent and application independent. It is defined in §5.2.2.2
691 as a functional interface, in terms of functional flows and logical signals.

692 The A-interface is user application protocol specific (e.g., Ethernet, IP). The functional description
693 of the A-interface is presented in §5.2.2.1. The A-interface is for further study.

694 All interim interfaces are independent of the type of media and are defined as functional (logical)
695 interfaces in the terms of functional flows and logical signals.

696

697

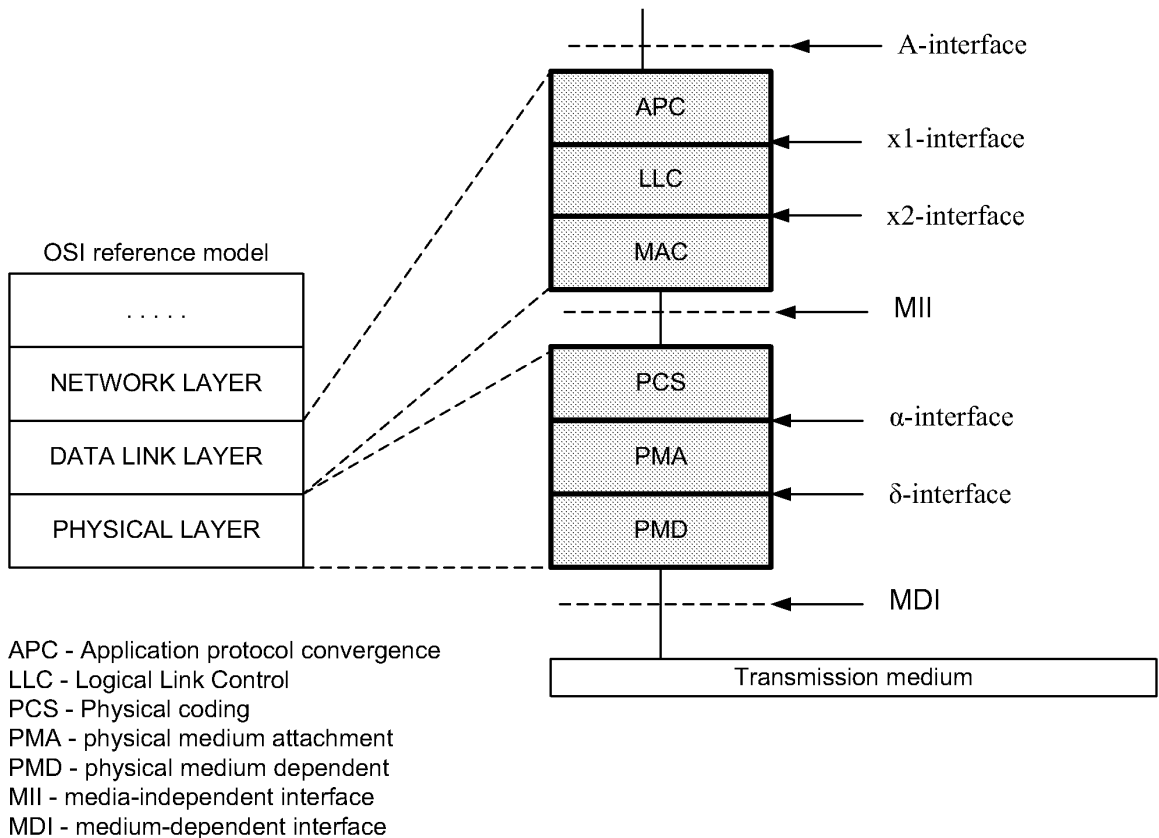

698
699

700

Figure 5-11/G.9960 – Protocol reference model of HN transceiver

701 The application protocol convergence sub-layer (APC) provides an interface with the application
 702 entity (AE), which operates with a client specific protocol, such as ethernet. The APC also provides
 703 the bit rate adaptation between the application (client) and the HN.

704 The logical link control (LLC) sub-layer coordinates transmission of HN nodes in accordance with
 705 requests from the domain master. In particular, it is responsible for establishing, managing, resetting
 706 and terminating all connections of the node inside the domain. The LLC also enforces Class of
 707 Service (CoS) and Quality of Service (QoS) constraints of the flow, defined for its various
 708 connections.

709 The MAC sub-layer controls access of the HN node to the medium using various media access
 710 protocols, which are for further study.

711 The PCS provides bit rate adaptation (data flow control) between the MAC and PHY and
 712 encapsulates transmit packets into the PHY frame and adds PHY-related control and management
 713 overhead. The PMA provides encoding of PHY frame content for transmission over the medium.
 714 The PMD modulates and demodulates PHY frames for transmission over the medium using
 715 orthogonal frequency division modulation (OFDM). By implementation, the PMD may include
 716 media-dependent adaptors for different media, including frequency shifting for pass-band
 717 transmission.

718 The layers above the data link layer (above the A-interface) are beyond the scope of G.9960.
719 Management functions are not presented in Figure 5-11.

720 **5.2.2 Interfaces - functional description**

721 This section contains the functional description of the G.9960 transceiver interfaces (A, MII, and
722 MDI) in terms of signal flows exchanged between corresponding entities. The description doesn't
723 imply any specific implementation of the transceiver interfaces.

724 **5.2.2.1 A-interface**

725 The A-interface is described in terms of primitives exchanged between the AE and DLL. Two
726 groups of primitives are defined: data primitives and control primitives, as described in Table 5-3.
727 Data primitives represent the data path of the A-interface, while control primitives represent the
728 control path. The format of the primitives is application specific, determined by the AE (application
729 data primitives, ADP).

730 **Table 5-3/G.9960 – A-interface signal flow description**

Primitive	Direction	Description
AIF_DATA.REQ	AE → DLL	Data from AE to DLL
AIF_DATA.CNF	DLL → AE	Data confirmation from DLL to AE
AIF_DATA.IND	DLL → AE	Data from DLL to AE
AIF_CTRL.REQ	AE → DLL	Control from AE to DLL
AIF_CTRL.CNF	DLL → AE	Control confirmation from DLL to AE
AIF_CTRL.IND	DLL → AE	Control from DLL to AE

731

732 **5.2.2.1.1 AIF_DATA.REQ**

733 The AIF_DATA.REQ primitive defines the transfer of an ADP from the AE to the DLL. The DLL
734 formats the ADP into an MSDU or transfers it to the DLL management.

735 Semantics of the primitive:

```

736 AIF_DATA.REQ {
737     destination address,
738     source address,
739     data,
740     length,
741     service class
742 }
```

743 The destination address may be an individual or a group address identifying the destination.

744 The source address is an individual address specifically identifying the source of the data unit
745 contained within the ADP.

746 The data specifies the actual data to be passed.

747 The length specifies the number of units to be transferred and is specific to the AE.

748 The service class indicates the quality of service required for this ADP.

749 **5.2.2.1.2 AIF_DATA.CNF**

750 The AIF_DATA.CNF primitive defines a confirmation from the DLL to the AE of the previously
751 received AIF_DATA.REQ primitive and is passed from the DLL to the AE after each received
752 AIF_DATA.REQ.

753 Semantics of the primitive:

```
754 AIF_DATA.CNF {  
755     status  
756 }
```

757 The status is a set of parameters (including rejection codes) describing the status of the ADP passed
758 to the DLL in the previous AIF_DATA.REQ primitive.

759 **5.2.2.1.3 AIF_DATA.IND**

760 The AIF_DATA.IND primitive defines the transfer of an ADP from the DLL to the AE. The
761 primitive is transferred to AE whenever the DLL has an ADP ready to be transferred. Semantics of
762 the primitive:

```
763 AIF_DATA.IND {  
764     destination address,  
765     source address,  
766     data,  
767     length,  
768     service class,  
769     reception status,  
770 }
```

771 The destination address may be an individual or a group address identifying the target.

772 The source address is an individual address specifically identifying the source of the data unit
773 contained within the ADP.

774 The data specifies the actual data to be passed.

775 The length specifies the number of units to be transferred and is specific to the AE.

776 The service class indicates the type of quality of service required for this ADP.

777 Status shall indicate the validity of the data unit that is delivered via the A-interface to the AE.

778 **5.2.2.1.4 AIF_CTRL.REQ**

779 The AIF_CTRL.REQ primitive defines a control request from the AE to the DLL. The DLL
780 executes the request according to the specified control operation.

781 Semantics of the primitive:

```
782 AIF_CTRL.REQ {  
783     control operand list  
784 }
```

785 The control operand list is specific per each control operation.

786 **5.2.2.1.5 AIF_CTRL.CNF**

787 The AIF_CTRL.CNF primitive defines a confirmation from the DLL to the AE of a previously
788 received AIF_CNTRL.REQ primitive and is passed from the DLL to the AE whenever the
789 confirmation on the received AIF_DATA.REQ is required.

790 Semantics of the primitive:

```
791 AIF_CTRL.CNF {
792     control operand list
793 }
```

794 The control operand list is specific per each control operation.

795 **5.2.2.1.6 AIF_CTRL.IND**

796 The AIF_CTRL.IND primitive defines a control indication from the DLL to the AE. This primitive
797 may be used to indicate to the AE whether the DLL is ready or not to receive another ADP.

798 Semantics of the primitive:

```
799 AIF_CTRL.IND {
800
801     control operand list
802 }
```

803 The control operand list is specific per each control operation.

804

805 **5.2.2.2 Medium-Independent Interface (MII)**

806 The MII is described in terms of signal flows exchange between the DLL and PHY layer. The MII
807 signal flows are presented in Table 5-4; the direction of each signal flow indicates the entity
808 originating the flow. Both transmit and receive data are exchanged in MAC protocol data units
809 (MPDUs). The format of MPDUs is for further study.

810 **Table 5-4/G.9960 – MII signal flow description**

Signal flow	Direction	Description
TX DATA	MAC → PHY	Flow of MPDUs for transmission
TX CLK	PHY → MAC	Transmit timing
RX DATA	PHY → MAC	Flow of received MPDUs
RX CLK	PHY → MAC	Receive timing
RX ERR	PHY → MAC	Error signal accompanies MPDU of a PHY frame received with errors
CRS	PHY → MAC	Carrier sense signal (physical or virtual)
NOTE – Signal flows presented in this table are functional; they are exclusively for descriptive purposes and do not imply any specific implementation.		

811

812 The described signal flows indicate the following specifics of the MII:

- 813 - the MII bit timing (clock) for both transmit and receive directions is determined by the PHY

- 814 - the CRS assists TX DATA flow control in case CSMA is used
- 815 - RX_ERR indicates that one or more components of the PHY frame carrying the received
- 816 MPDU are in error; the DLL is responsible for processing of the packets and deciding which
- 817 MPDUs to keep, discard, or retransmit.

818 **5.2.2.3 Medium-dependent interface (MDI)**

819 Functional characteristics of the MDI are described by two signal flows:

- 820 - transmit signal (TX DATA) is the flow of frames transmitted onto the medium
- 821 - receive signal (RX DATA) is the flow of frames received from the medium.

822 **5.2.3 Functional model of an HN transceiver**

823 The functional model of an HN transceiver is presented in Figure 5-12. It addresses a regular node,
824 a master node, and a relay node (including DAP), which differ by their MAC, LLC and upper layer
825 functionalities.

826 The PMD function depends on the medium on which the transceiver operates. It can be configured
827 for base-band or pass-band operation. The PCS provides bit rate adaptation (data flow control)
828 between the MAC and the PHY and encapsulates transmit MAC frames into PHY frames. The
829 transmit PHY frame is further encoded in the PMA to meet the corresponding PMD. The
830 functionality of the PCS, and the PMA is the same for any medium, but their parameters are
831 medium-specific. By appropriate parameter settings, any HN node can be configured to operate on
832 any type of wiring in both base-band and pass-band modes.

833

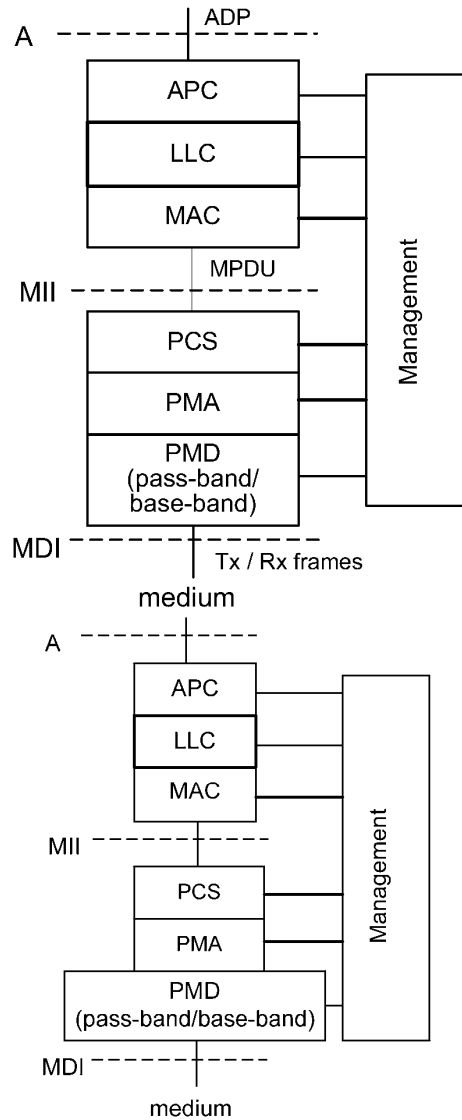

834

835

836

Figure 5-12/G.9960 – Functional model of HN transceiver

837

838 The detailed description of the functional model of the PHY layer is presented in §7.1. The detailed
839 description of the functional model of the DLL is for further study.

840

841 **6 Profiles**

842 Profiles are intended to address G.9960 nodes with significantly different levels of complexity.

843 Details are for further study.

844 7 **Physical layer specification**

845 7.1 **Media independent specification**

846 7.1.1 **Functional model of the PHY**

847 The functional model of the PHY is presented in Figure 7-1. The MII and MDI are, respectively,
 848 two demarcation reference points between the PHY and MAC and between the PHY and
 849 transmission medium. Internal reference points δ and α , respectively, show separation between the
 850 PMD and PMA and between the PCS and PMA.

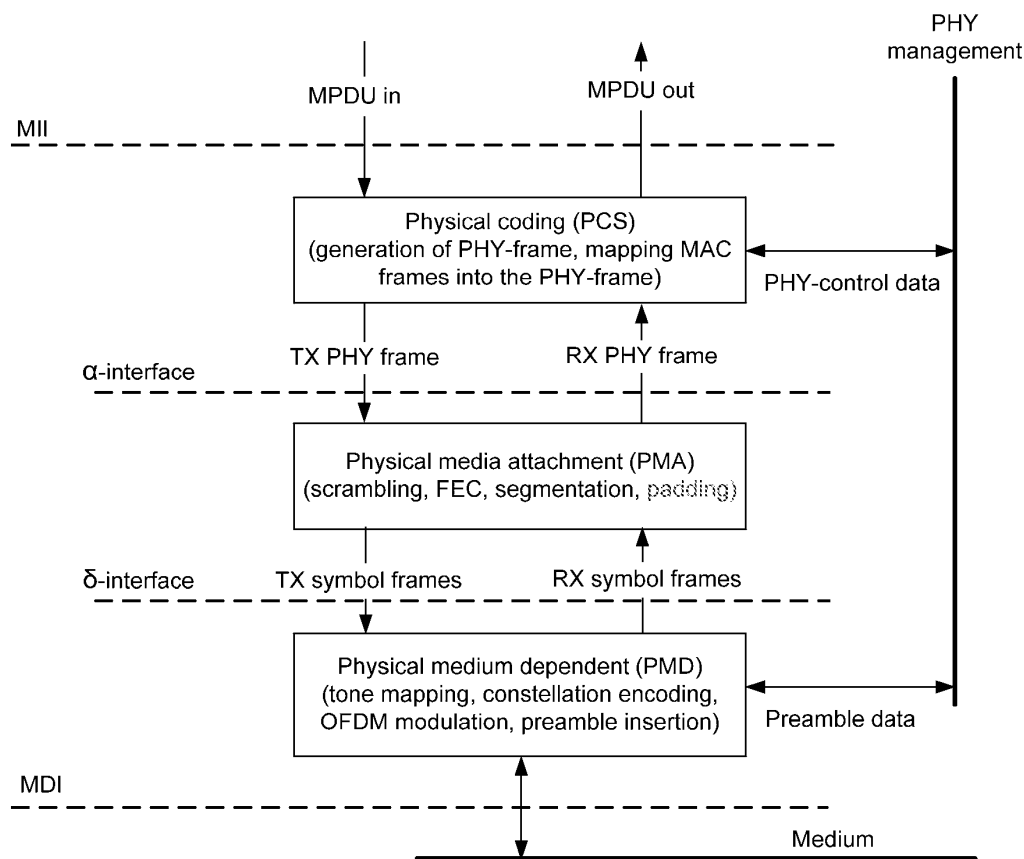

851
852

853 **Figure 7-1/G.9960 – Functional model of the PHY**

854 In the transmit direction, data enters the PHY from the MAC via MII by blocks of bytes called
 855 MAC protocol data units (MPDUs). The incoming MPDU, whether it belongs to a data frame or a
 856 control frame, is mapped into the PHY frame originated in the PCS, scrambled and encoded in the
 857 PMA, modulated in the PMD, and transmitted over the medium using OFDM modulation with
 858 relevant parameters. In the PMD, a preamble is added to assist synchronization and channel
 859 estimation in the receiver.

860 In the receive direction, frames entering from the medium via the MDI are demodulated and
 861 decoded. The recovered MPDUs are forwarded to MAC via the MII. The recovered PHY-frame
 862 headers are processed in the PHY to extract the relevant frame parameters specified in §7.1.2.3.
 863

864 **7.1.2 Physical coding sub-layer (PCS)**

865 The functional model of the PCS is presented in Figure 7-2. It is intended to describe in more detail
 866 the PCS functional block presented in Figure 7-1.

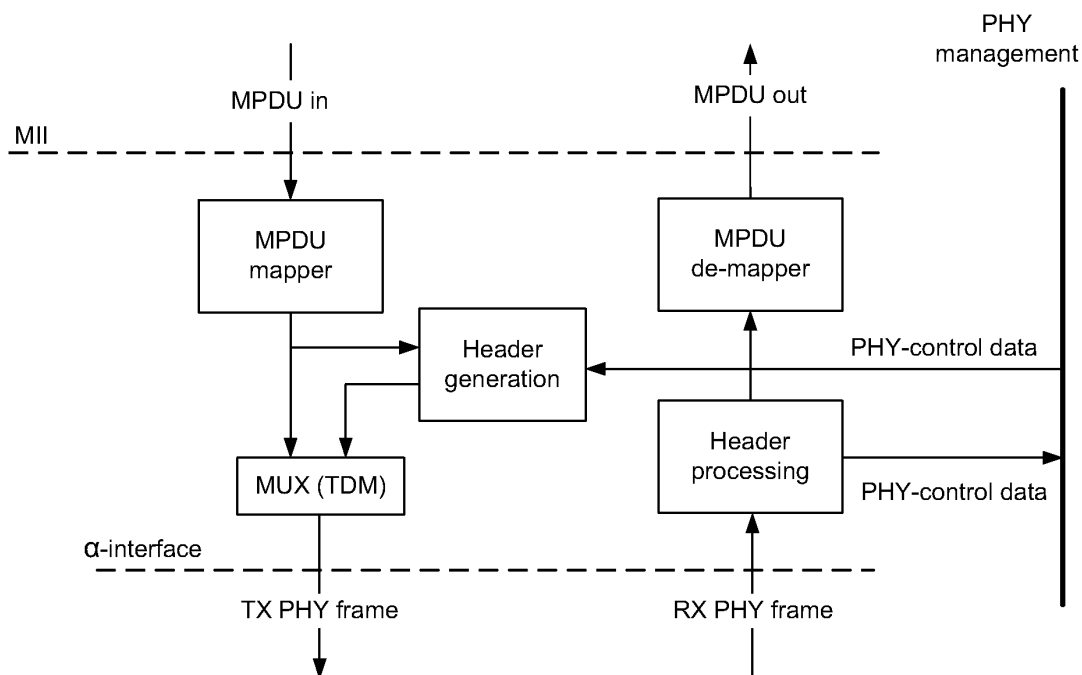

867

868 **Figure 7-2/G.9960 – Functional model of PCS**

869 In the transmit direction, the incoming MPDU is mapped into a payload field of a PHY frame
 870 (§7.1.2.1) as described in §7.1.2.2. Further, the PHY-frame header (§7.1.2.3) is added to form a TX
 871 PHY frame. The TX PHY frame is passed via the α-interface for further processing in the PMA.

872 In the receive direction, the decoded PHY-frame payload and header are processed and originally
 873 transmitted MPDUs are recovered from the payloads of properly received PHY frames and
 874 submitted to the MII. Relevant control information conveyed in the PHY-frame header is processed
 875 and submitted to the PHY management entity, Figure 7-2.

876 **7.1.2.1 PHY frame**

877 The format of the PHY frame is presented in Figure 7-3. The PHY frame at the α-interface includes
 878 header, and payload. Preamble is added to the PHY frame in the PMD, as described in §7.1.4.5.
 879 Preamble does not bear any user or management data and is intended for synchronization and initial
 880 channel estimation.

881

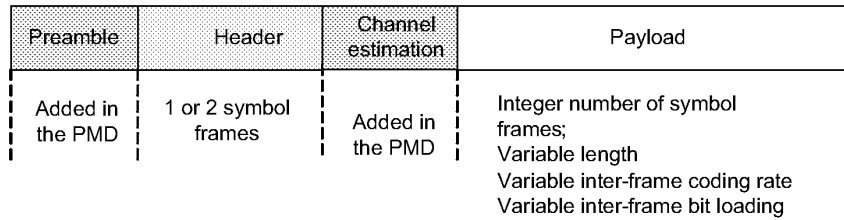

882

883

884

Figure 7-3/G.9960 – Format of the PHY frame

885 The PHY-frame header and payload shall each contain an integer number of OFDM symbols.

886 The length of the PHY-frame header always fits integer number of symbols and is transmitted using
887 a single pre-defined set of modulation and coding parameters (see §7.1.3.4).

888 The length of the payload may vary from frame to frame; payload may be of zero length. For
889 payload, different coding parameters and bit loading can be used in different frames, depending on
890 channel/noise characteristics and QoS requirements.

891 **7.1.2.2 MPDU mapping**

892 The bits of the MPDU shall be mapped into the payload in ascending sequential order. The first bit
893 of the MPDU shall be the first transmitted bit of the payload.

894 **7.1.2.3 PHY-frame header**

895 The PHY-frame header is PHY_H bits long and is composed of a common part and a variable part.
896 The common part contains fields that are common for all PHY-frame types. The variable part
897 contains fields according to the PHY-frame type. PHY-frame type is indicated by the FT field. The
898 PAD fields fit the length of the header of different PHY frame-types to the standard values of PHY_H
899 bits. The content of the header is protected by the 16-bit header check sequence (HCS).

900 The fields of the PHY-frame header are defined in Table 7-1

901

902

Table 7-1/G.9960 – PHY-frame header fields

Field	Octet	Field Size [Bits]	Description	
FT	0	4	Frame type	Common part
DOD	0	4	Domain ID	
SID	1	8	The device ID of the source node	
DID	2	8	The device ID of the destination node	
MI	3	1	Multicast indication identifies whether the DID is a multicast destination	
PHI	3	1	Post header indication identifies whether the first payload symbol after the header is a PRBS symbol or a data symbol	
Reserved	3	6	Reserved by ITU-T	
Duration	4-5	16	The PHY frame transmission duration	
...	6-18			Variable part
HCS	19-20	16	Header check sequence	Common part

903

904 **7.1.2.3.1 Common part fields**

905 **7.1.2.3.1.1 Frame Type (FT)**

906 The Frame type (FT) field is a 4-bit field which indicates the type of the PHY frame transmitted.

907

908 Table 7-2 describes the PHY-frame types.

909

Table 7-2/G.9960 –PHY-frame types

Type	Value	Description
MAP	0	MAP frame
MSG	1	Data and management frame
ACK	2	ACK control frame
RTS	3	RTS control frame
CTS	4	CTS control frame
RMAP	5	Repeated MAP frame
PROBE	6	Probe frame
ACKRQ	7	ACK retransmission request frame
Reserved	8-15	Reserved for future use

910

911 **7.1.2.3.1.2 Domain ID (DOD)**

912 The DOD is a 4-bit field that identifies the domain to which the source and destination devices of
913 the PHY frame belong. DOD shall be represented as a 4-bit unsigned integer in the valid range from
914 0 to 15. The method for choosing DOD is for further study.

915 **7.1.2.3.1.3 Source ID (SID)**

916 SID is the device ID that was assigned to the G.9960 source node of the PHY frame during its
917 registration. The SID shall be represented by an 8-bit unsigned integer with valid values in the
918 range from 0 to 250. Value 0 shall be used as the default device ID of a node attempting to join the
919 network.

920 **7.1.2.3.1.4 Destination ID (DID)**

921 The DID is the DEVICE_ID value identifying the G.9960 destination node of the PHY frame. The
922 DID shall be represented by an 8-bit unsigned integer with valid values in the range from 0 to 250.
923 It could be equal to the device ID assigned during node registration, or to the value reserved for
924 broadcast ID or multicast ID.

925 **7.1.2.3.1.5 Multicast Indication (MI)**

926 The multicast indication shall be set when the DID is a multicast/broadcast destination
927 DEVICE_ID.

928 **7.1.2.3.1.6 Post Header Indication (PHI)**

929 The PHI bit, when set, shall indicate to all nodes that the first payload symbol following the header
930 is a PRBS symbol. Otherwise the first payload symbol shall be a data symbol.

931

932 **7.1.2.3.1.7 Duration**

933 The duration field contains a 16-bit unsigned integer that shall describe the total PHY frame
934 transmission time (preamble, header and payload) for virtual carrier sensing in multiples of
935 0.25µsec.

936 In the case of an RTS frame, the total duration indicated in this field shall represent the total
937 duration of the following sequence:

- 938 • The transmission time of the RTS PHY frame
- 939 • The transmission time of the CTS PHY frame
- 940 • The PHY frame that follows the CTS PHY frame, and
- 941 • The two inter-frame gaps between the above frames
- 942 • If ACK is required, the duration of the inter-frame gap and the ACK-frame

943 In the case of a CTS frame, the total duration indicated in this field shall repeat the duration
944 expressed in the preceding RTS PHY frame minus the RTS PHY frame transmission time and the
945 inter-frame gap that follows the RTS PHY frame.

946 **7.1.2.3.1.8 Header check sequence (HCS)**

947 The HCS field is intended for PHY-frame header verification. The HCS is a 16-bit cyclic
948 redundancy check (CRC) and shall be computed over all the fields of the PHY-frame header in the
949 order they are transmitted, starting with the MSB of the frame type (FT) field and ending with the
950 LSB of the last field of the PHY Frame.

951 The HCS shall be computed using the following generator polynomial of degree 16:

$$952 \quad G(x) = x^{16} + x^{12} + x^5 + 1.$$

953 The value of the HCS shall be the remainder after the contents (treated as a polynomial where the
954 first input bit is associated with the highest degree, X^{PHY_H-17} , where PHY_H is the header length in
955 bits, and the last input bit is associated with X^0) of the calculation fields is multiplied by x^{16} and
956 then divided by $G(x)$.

957 The HCS field shall be transmitted starting with the coefficient of the highest order term (MSB).

958

959 **7.1.2.3.2 Variable part specific fields**

960 The following paragraph details the specific PHY-frame header fields for each PHY-frame type
961 variable part.

962 For some frame types, a pad may be required at the end of frame type specific fields to fit the PHY-
963 frame header variable part size.

964 **7.1.2.3.2.1 MSG PHY-frame type specific fields**

965 Table 7-3 lists the MSG frame type specific PHY-frame header fields.

966

Table 7-3/G.9960 – MSG PHY-frame type specific fields

Field	Field size [bits]
MSTRDTCT	1
RPRQ	2
RTSRQ	1
BRURQ	For further study
BLKSZ	2
FEC RATE	3
FLOW_ID/PRI	8
REP	3
FCF	3
SI	4
FRMSN	2
TPN	11
Pad	padding up to PHY _H bits

967 **7.1.2.3.2.1.1 “Master is detected” indication (MSTRDTCT)**

968 MSTRDTCT indicates reception of a MAP. It is a 1-bit field that shall be set by a node, in each
 969 PHY-frame header it transmits, when this node has received a MAP (either directly from the
 970 domain master or repeated MAP) that the current MAC cycle is associated with. This indication
 971 shall be used by nodes (including the backup domain master if it exists) to determine whether the
 972 current domain master has failed.

973 **7.1.2.3.2.1.2 Reply required (RPRQ)**

974 RPRQ instructs the receiver whether to respond with acknowledgement for this PHY frame. It is a
 975 2-bit field that shall be coded as shown in Table 7-4.

976

Table 7-4/G.9960 – RPRQ field possible values

RPRQ value	Interpretation
00	The receiver shall not acknowledge this PHY frame
01	The receiver shall acknowledge via an Imm-ACK frame
10 - 11	Reserved by ITU-T

977 **7.1.2.3.2.1.3 RTS/CTS required (RTSRQ)**

978 RTSRQ indicates whether to use the RTS/CTS sequence. It is a 1-bit field. When RTSRQ is set to
 979 one, all nodes shall use the RTS/CTS sequence when communicating with the node that set RTSRQ
 980 for all PHY frames after the current PHY frame, until this node indicates otherwise by setting the
 981 bit to zero.

982 **7.1.2.3.2.1.4 Bandwidth reservation update request (BRURQ)**

983 This field is for further study.

984 **7.1.2.3.8.1.5 Block size (BLKSZ)**

985 BLKSZ indicates the information block size of the FEC codeword that is used by the transmitter for
 986 the payload of the PHY frame. It is a 2-bit field that shall be coded as shown in Table 7-5.

987 **Table 7-5/G.9960 – Interpretation of the BLKSZ field**

BLKSZ value	Interpretation
00	for the 120 byte information block size used for payload
01	for the 540 byte information block size used for payload
10-11	Reserved by ITU-T

988

989 **7.1.2.3.2.1.6 FEC_RATE**

990 FEC_RATE indicates the FEC coding rate that is used for encoding of the payload. It is a 3-bit
 991 unsigned integer field that shall be coded as shown in Table 7-6.

992 **Table 7-6/G.9960 – Interpretation of the FEC_RATE field**

FEC_RATE value	Interpretation
000	Reserved by ITU
001	1/2
010	2/3
011	5/6
100	16/18
101	20/21
110-111	Reserved by ITU

993

994 **7.1.2.3.2.1.7 Flow identifier (FLOW_ID) and priority (PRI)**

995 FLOW_ID/PRI is an 8-bit unsigned integer field that shall contain the FLOW_ID of the blocks
 996 aggregated in the frame (field values in the range 8-254), or the priority of the blocks aggregated in
 997 the frame if the field value is between 0 and 7.

998 **7.1.2.3.2.1.8 Repetitions (REP)**

999 REP indicates the nominal number of repetitions that were used for encoding the payload in this
 1000 PHY frame. It is a 3-bit unsigned integer field that shall be coded as shown in Table 7-7.

1001

Table 7-7/G.9960 – Repetitions field possible values

REP value	Interpretation
000	Reserved by ITU-T
001	1 (no repetitions)
010	2
011	3
100	4
101	6
110 - 111	Reserved by ITU-T

1002

1003 **7.1.2.3.2.1.9 FEC concatenation factor (FCF)**

1004 FCF indicates the values of parameters H and z (see §7.1.3.3.1). It is a 3-bit unsigned integer field
1005 that shall be coded as shown in Table 7-8.

1006

Table 7-8/G.9960 – FEC concatenation factor (FCF) possible values

Value	H	z
000	1	0
001	Reserved by ITU-T	Reserved by ITU-T
010	2	0
011	2	1
100	4	0
101	4	1
110	4	2
111	4	3

1007

1008 **7.1.2.3.2.1.10 Scrambler initialization (SI)**

1009 SI contains the scrambler initialization value ($C_4C_3C_2C_1$) that was used by the transmitter for this
1010 frame. It is a 4-bit field that shall be used to initialize the scrambler, as described in §7.1.3.1.

1011 **7.1.2.3.2.1.11 Frame sequence number (FRMSN)**

1012 FRMSN holds the transmitted frame sequence number sent to the same destination (DID). It is a 2-
1013 bit unsigned integer field.

1014 The FRMSN shall be initialized to zero upon the first PHY frame containing payload sent for a
1015 certain DID and shall be incremented by one upon each additional PHY frame containing payload
1016 sent to the same DID. When the FRMSN value exceeds the maximum value of 3, the FRMSN shall
1017 wrap-around to zero.

1018 **7.1.2.3.2.1.12 Transmission profile number (TPN)**

1019 TPN includes parameters that, in conjunction with SID, allow the receiver to determine the
1020 transmission profile used by the transmitter for the particular PHY frame.

1021 One or more TPN values can be used between the same transmitter and receiver for different flows
1022 or for different positions within the MAC cycle of the same flow.

1023 It is an 11-bit field that shall indicate the bit allocation table (BAT) of the current PHY frame via
 1024 the BAT identifier (BAT_ID), the sub-carrier grouping (see §7.1.4.2.4) via the grouping identifier
 1025 (GRP_ID), and the guard interval used for payload via the guard interval identifier (GI_ID) as
 1026 shown in Table 7-9.

1027 **Table 7-9/G.9960 – Interpretation of the TPN field**

Field	Bits	Description
BAT_ID	10:6	Bit allocation table identifier (see Table 7-20)
GRP_ID	5:3	Sub-carrier grouping identifier (see Table 7-10)
GI_ID	2:0	Identifier of the guard interval used for payload (see Table 7-11)

1028

1029 **Table 7-10/G.9960 – Format of the GRP_ID**

GRP_ID value	[Bits]	Description
0	000	Default - No sub-carrier grouping
1	001	Sub-carrier grouping of 2 sub-carriers
2	010	Sub-carrier grouping of 4 sub-carriers
3	011	Sub-carrier grouping of 8 sub-carriers
4	100	Sub-carrier grouping of 16 sub-carriers
5-7	101-111	Reserved by ITU-T

1030

1031 **Table 7-11/G.9960 – Format of the GI_ID**

GI_ID value	[Bits]	Description
0-6	000-110	N_{GI} guard interval [samples] $k \times N/32$, $k = 1, 2, 3, \dots, 7$ where $k = GI_ID + 1$, N is the size of the DFT
7	111	$k = 8$ (GI_ID=7) $N_{GI} = N_{GI-DF} = N/4$

1032

1033 **7.1.2.3.2.2 ACK PHY-frame type specific fields**

1034 For further study.

1035 **7.1.2.3.2.3 MAP and RMAP PHY-frame type specific fields**

1036 Table 7-12 lists the MAP and RMAP frame type specific PHY-frame header fields.

1037 **Table 7-12/G.9960 – MAP and RMAP PHY-frame type specific fields**

1038
1039
1040
1041

Field	Size in bits
NTR	32
SI	4
Pad	padding up to PHY _H

1042 **7.1.2.3.2.3.1 Network time reference (NTR)**

1043 NTR is used for synchronizing nodes to the domain master transmit clock. It is a 32-bit unsigned
1044 integer field. The NTR shall indicate the time stamp of the first sample of the first OFDM symbol
1045 of a MAP or RMAP PHY frame that is sent according to the transmitting node's clock with a
1046 resolution of 10ns.

1047 The NTR value shall use modulo arithmetic (modulo 2^{32}) where G.9960 nodes shall be capable to
1048 follow the network's clock based on the NTR value.

1049 NOTE – Nodes that are hidden from the domain master shall synchronize to the
1050 domain master time via the RMAP PHY frame received from another G.9960
1051 node that repeats the domain master's MAP.

1052 **7.1.2.3.2.3.2 Scrambler initialization (SI)**

1053 SI contains the scrambler initialization value ($C_4C_3C_2C_1$) that was used by the domain master for
1054 this frame. It is a 4-bit field that shall be used to initialize the scrambler, as described in §7.1.3.1.

1055 **7.1.2.3.2.4 RTS PHY-frame type specific fields**

1056 Table 7-13 lists the RTS PHY-frame type specific PHY-frame header fields:

1057 **Table 7-13/G.9960 – RTS PHY-frame type specific fields**

1058
1059
1060

Field	Size in bits
CID	8
Pad	padding up to PHY _H

1061 **7.1.2.3.2.4.1 CTS proxy ID (CID)**

1062 CID contains the DEVICE_ID of the node that should respond in CTS for multicast traffic. It is an
1063 8-bit unsigned integer field with valid values in the range from 1 to 250.

1064 **7.1.2.3.2.5 CTS PHY-frame type specific fields**

1065 Specific fields of the CTS PHY-frame type are listed in Table 7-14.

1066 **Table 7-14/G.9960 – Specific fields of the CTS PHY-frame type**

1067
1068
1069

Field	Size in bits
Pad	padding up to PHY _H

1070 **7.1.2.3.2.6 PROBE PHY-frame type specific fields**

1071 Table 7-15 lists the PROBE PHY-frame type specific PHY-frame header fields:

1072 **Table 7-15/G.9960 – PROBE PHY-frame type specific fields**

Field	Size in bits
PRBTYPE	4
PRBSYM	5
APSDC	5
Pad	padding up to PHY _H

1073 **7.1.2.3.2.6.1 PROBE frame type (PRBTYPE)**

1074 PRBTYPE indicates the type of the PROBE frame. It is a 4-bit field that shall be coded as shown in
1075 Table 7-16.

1076 **Table 7-16/G.9960 – PRBTYPE field values**

Value	Interpretation
0000	Silent PROBE frame
0001	Channel assessment PROBE frame
0010-1111	Reserved by ITU-T

1077

1078 **7.1.2.3.2.6.2 Probe symbols (PRBSYM)**

1079 PRBSYM indicates the number of OFDM payload symbols in the PROBE frame. It is a 5-bit field
1080 that shall be coded as shown in Table 7-17

1081

1082 **Table 7-17/G.9960 – PRBSYM field values**

Value	Interpretation
00000	4 Payload symbols
00001	8 Payload symbols
00010	12 Payload symbols
00011	16 Payload symbols
....
01111	64 Payload symbols
1xxxx	Reserved by ITU-T

1083

1084

1085 **7.1.2.3.2.6.3 Actual PSD ceiling (APSDC)**

1086 APSDC indicates the PSDC value that is used in the current transmitting signal. The field shall be
1087 coded as a 5-bit unsigned value. The valid values are in the range from 0 to 25, plus 0x1F. Values
1088 from 0 to 25 correspond to actual an PSD ceiling in the range of –50 dBm/Hz to –100 dBm/Hz in 2
1089 dB steps. The special value 0x1F indicates that no PSD ceiling is applied.

1090 **7.1.2.3.2.7 ACKRQ frame type specific fields**

1091 For further study.

1092

1093 **7.1.3 Physical medium attachment (PMA) sub-layer**

1094 The functional model of the PMA is presented in Figure 7-4. It is intended to describe in more
1095 detail the PMA functional block presented in Figure 7-1.

1096 In the transmit direction, the incoming PHY frame (except for preamble and channel estimation
1097 symbols) at the α -interface has a format as defined in §7.1.2. Both the header bits and the payload
1098 bits of the incoming frame are scrambled as described in §7.1.3.1. The header bits of the incoming
1099 frame are encoded as described in §7.1.3.4. The payload bits are encoded, as described in §7.1.3.3.
1100 The parameters of payload encoder are controlled by the PHY management entity.

1101 After encoding, the header and payload are each segmented into an integer number of symbol
1102 frames as described in §7.1.3.5.1. The obtained symbol frames of the header and the payload are
1103 submitted to the PMD (at the δ -interface) for modulation and transmission over the medium.

1104 In the receive direction, all necessary inverse operations of decoding, and de-scrambling are
1105 performed on the received symbol frames. The recovered PHY-frame header and payload are
1106 submitted to the α -interface for further processing in the PCS.

1107

1108

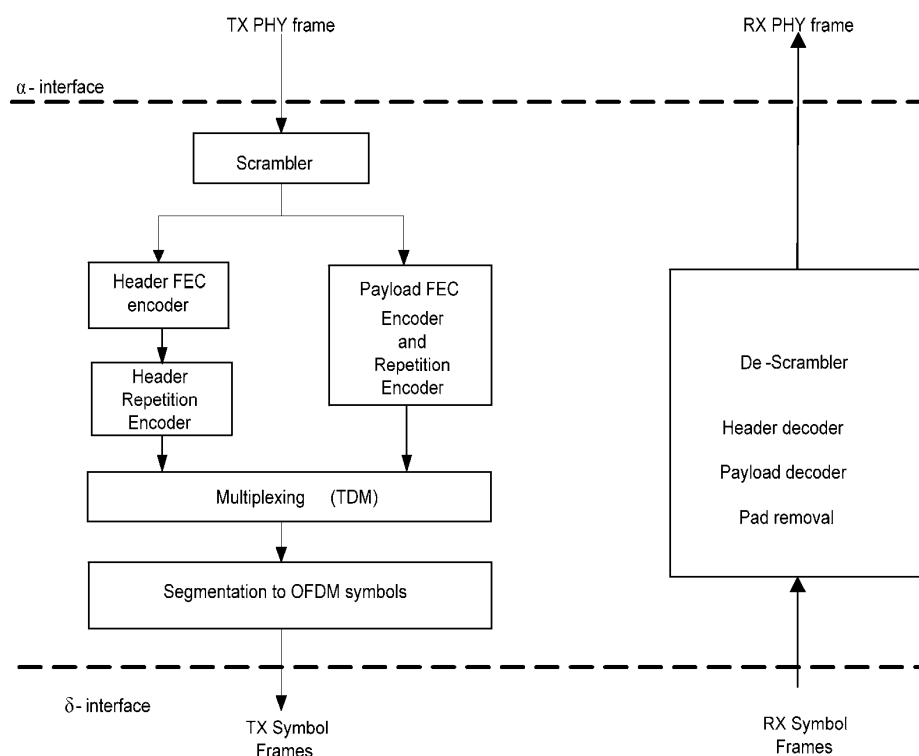

1109

1110

Figure 7-4/G.9960 – Functional model of PMA

1111 **7.1.3.1 Scrambling**

1112 All data starting from the first bit of the PHY-frame header and ending by the last bit of the payload
 1113 shall be scrambled with a pseudo-random sequence generated by the linear feedback shift register
 1114 (LFSR) with the polynomial $p(x)=x^{23}+x^{18}+1$, as shown in Figure 7-5.

1115
 1116

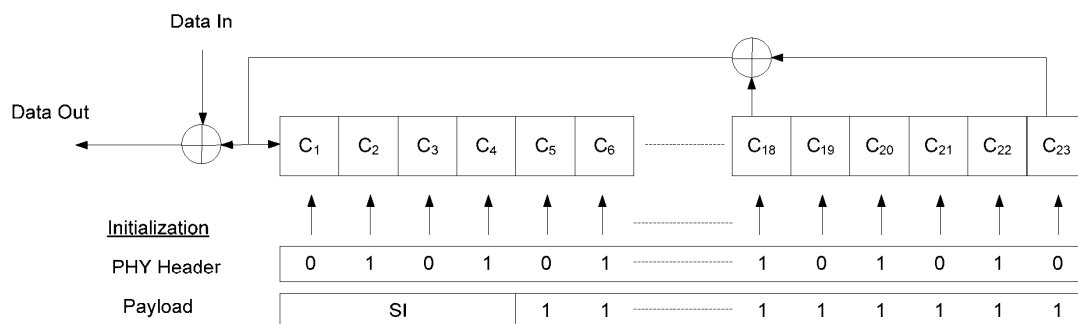

1117

1118 **Figure 7-5/G.9960 – Scrambler; $p(x) = x^{23}+x^{18}+1$**

1119

1120 The LFSR generator shall be initialized at the first bit of the header with the initialization vector
 1121 equal to 0x2AAAAA (where the LSB corresponds to C_1); this initialization is used for scrambling
 1122 of the header data. A second initialization may be performed immediately after the header, at the
 1123 first bit of the payload, and is used for scrambling of the payload data. For the second initialization,
 1124 the first four bits of the LFSR (C_1 to C_4) shall be set to the value of SI (Scrambler Initialization),
 1125 while all other bits C_5 to C_{23} shall be initialized to 1. The value of $SI = C_4C_3C_2C_1$ is communicated
 1126 in the header as described in §7.1.2.3.

1127 The special value 0x0 for SI indicates that the scrambler is not re-initialized between the header and
 1128 payload. The initialization of the SI field to values other than the special value is optional.

1129

1130 NOTE – the method for generating SI values is beyond the scope of this Recommendation.

1131 **7.1.3.2 FEC encoding**

1132 The FEC encoding scheme is shown in Figure 7-6. The scheme consists of a systematic QC-LDPC-
 1133 BC encoder and a puncturing mechanism. The parameters of the FEC encoding scheme are:

- 1134 - the number of incoming information bits, K (information block of bits);
- 1135 - the number of coded bits, N_M (coded block of bits);
- 1136 - the number of parity-check bits, N_M-K ;
- 1137 - the number of output bits, $N_{FEC} \leq N_M$, (FEC codeword, whose size depends on the
 1138 puncturing pattern);
- 1139 - the mother coding rate, $R_M = K/N_M$, defined as the coding rate before puncturing.
- 1140 - the coding rate, $R = K/N_{FEC}$, defined as the coding rate after puncturing.

1141 The information block size shall be one of the values specified in Table 7-19.

1142

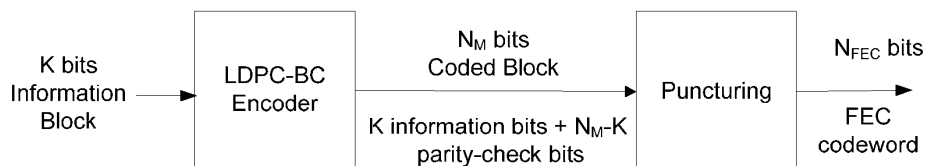

1143

1144

Figure 7-6/G.9960 – FEC Encoder

1145 The encoder shall support mother codes with rates $R_M = 1/2$, $R_M = 2/3$ and $R_M = 5/6$. From
 1146 these mother codes, codes with higher coding rates shall be obtained through puncturing, as
 1147 described in §7.1.3.2.1.1. The Puncturing block shall support patterns providing all coding rates
 1148 presented in Table 7-19.

1149

1150 The coding rate of the mother code, $R_M = K / N_M$, is determined by a $(N_M - K) \times N_M$ size parity-
 1151 check matrix \mathbf{H} composed by an array of $c \times t$ circulant $b \times b$ sub-matrices $\mathbf{A}_{i,j}$:

1152

$$\mathbf{H} = \begin{bmatrix} \mathbf{A}_{1,1} & \mathbf{A}_{1,2} & \cdots & \mathbf{A}_{1,t} \\ \mathbf{A}_{2,1} & \mathbf{A}_{2,2} & \cdots & \mathbf{A}_{2,t} \\ \vdots & \vdots & \ddots & \vdots \\ \mathbf{A}_{c,1} & \mathbf{A}_{c,2} & \cdots & \mathbf{A}_{c,t} \end{bmatrix}.$$

1153

1154 The parameters c, t ($0 < c \leq t$) imply a rate $R_M = (t - c) / t$. By selecting different sets of
 1155 c, t , different rates can be obtained.

1156 The sub-matrices $\mathbf{A}_{i,j}$ are either a rotated identity or a zero matrices and have a size of $b \times b$, where
 1157 parameter $b = N_M / t$ is called the *expansion factor* of \mathbf{H} and controls the code block size, N_M .

1158

1159 The parity-check matrix, \mathbf{H} , is described in its compact form:

1160

$$\mathbf{H}_c = \begin{bmatrix} a_{1,1} & a_{1,2} & \cdots & a_{1,t} \\ a_{2,1} & a_{2,2} & \cdots & a_{2,t} \\ \vdots & \vdots & \ddots & \vdots \\ a_{c,1} & a_{c,2} & \cdots & a_{c,t} \end{bmatrix}$$

1161 A zero sub-matrix in position (i, j) is labeled with $a_{i,j} = -1$, and a rotated identity sub-matrix is
 1162 labelled with a positive integer number $a_{i,j}$ defining the number of right column shifts $\hat{a}_{i,j}$ modulo b
 1163 of the identity matrix. The relation between $a_{i,j}$ and $\hat{a}_{i,j}$ is given by

1164

$$\hat{a}_{i,j} = \begin{cases} a_{i,j} & a_{i,j} < 0, \\ \left\lfloor a_{i,j} \cdot \frac{b}{96} \right\rfloor & a_{i,j} \geq 0. \end{cases}$$

1165 where $\lfloor x \rfloor$ is the integer part of variable x .

1166 The compact form of parity-check matrix of mother code H_c with rate $R_M=1/2$ ($t = 24, c = 12$) shall
 1167 be:

1168

1169 -1 94 73 -1 -1 -1 -1 -1 55 83 -1 -1 7 0 -1 -1 -1 -1 -1 -1 -1 -1 -1
 1170 -1 27 -1 -1 -1 22 79 9 -1 -1 -1 12 -1 0 0 -1 -1 -1 -1 -1 -1 -1 -1 -1
 1171 -1 -1 -1 24 22 81 -1 33 -1 -1 -1 0 -1 -1 0 0 -1 -1 -1 -1 -1 -1 -1 -1 -1
 1172 61 -1 47 -1 -1 -1 -1 -1 65 25 -1 -1 -1 -1 -1 0 0 -1 -1 -1 -1 -1 -1 -1
 1173 -1 -1 39 -1 -1 -1 84 -1 -1 41 72 -1 -1 -1 -1 -1 0 0 -1 -1 -1 -1 -1 -1 -1
 1174 -1 -1 -1 -1 46 40 -1 82 -1 -1 -1 79 0 -1 -1 -1 -1 0 0 -1 -1 -1 -1 -1 -1 -1
 1175 -1 -1 95 53 -1 -1 -1 -1 -1 14 18 -1 -1 -1 -1 -1 -1 -1 0 0 -1 -1 -1 -1 -1
 1176 -1 11 73 -1 -1 -1 2 -1 -1 47 -1 -1 -1 -1 -1 -1 -1 -1 0 0 -1 -1 -1 -1 -1
 1177 12 -1 -1 -1 83 24 -1 43 -1 -1 -1 51 -1 -1 -1 -1 -1 -1 -1 -1 0 0 -1 -1 -1
 1178 -1 -1 -1 -1 -1 94 -1 59 -1 -1 70 72 -1 -1 -1 -1 -1 -1 -1 -1 -1 0 0 -1 -1
 1179 -1 -1 7 65 -1 -1 -1 -1 39 49 -1 -1 -1 -1 -1 -1 -1 -1 -1 -1 -1 0 0
 1180 43 -1 -1 -1 -1 66 -1 41 -1 -1 -1 26 7 -1 -1 -1 -1 -1 -1 -1 -1 -1 -1 -1 0

1181

1182 The compact form of parity-check matrix of mother code H_c with rate $R_M=2/3$ ($t = 24, c = 8$) shall
 1183 be:

1184

1185 2 -1 19 -1 47 -1 48 -1 36 -1 82 -1 47 -1 15 -1 95 0 -1 -1 -1 -1 -1 -1 -1
 1186 -1 69 -1 88 -1 33 -1 3 -1 16 -1 37 -1 40 -1 48 -1 0 0 -1 -1 -1 -1 -1 -1 -1
 1187 10 -1 86 -1 62 -1 28 -1 85 -1 16 -1 34 -1 73 -1 -1 -1 0 0 -1 -1 -1 -1 -1
 1188 -1 28 -1 32 -1 81 -1 27 -1 88 -1 5 -1 56 -1 37 -1 -1 -1 0 0 -1 -1 -1 -1 -1
 1189 23 -1 29 -1 15 -1 30 -1 66 -1 24 -1 50 -1 62 -1 -1 -1 -1 -1 0 0 -1 -1 -1
 1190 -1 30 -1 65 -1 54 -1 14 -1 0 -1 30 -1 74 -1 0 -1 -1 -1 -1 -1 0 0 -1 -1
 1191 32 -1 0 -1 15 -1 56 -1 85 -1 5 -1 6 -1 52 -1 0 -1 -1 -1 -1 -1 0 0
 1192 -1 0 -1 47 -1 13 -1 61 -1 84 -1 55 -1 78 -1 41 95 -1 -1 -1 -1 -1 -1 0

1193

1194 The compact form of parity-check matrix of mother code H_c with rate $R_M=5/6$ ($t = 24, c = 4$) shall
 1195 be:

1196

1197 1 25 55 -1 47 4 -1 91 84 8 86 52 82 33 5 0 36 20 4 77 80 0 -1 -1
 1198 -1 6 -1 36 40 47 12 79 47 -1 41 21 12 71 14 72 0 44 49 0 0 0 0 -1
 1199 51 81 83 4 67 -1 21 -1 31 24 91 61 81 9 86 78 60 88 67 15 -1 -1 0 0
 1200 50 -1 50 15 -1 36 13 10 11 20 53 90 29 92 57 30 84 92 11 66 80 -1 -1 0

1201

1202 The codeword at the output of the Puncturing block is of size $N_{FEC} \leq N_M$. The bits shall be output in
 1203 the ascending order of codeword indices determined by vector \mathbf{v}' (see §7.1.3.2.1.1); with this order
 1204 the first information bit incoming the encoder will be the first at the output of the puncturing.

1205 **7.1.3.2.1 Encoder**

1206 The encoder shall support coded block sizes and rates presented in Table 7-19. The parity-check
 1207 matrix \mathbf{H} used to encode a block of information bits is selected according to the mother code
 1208 indicated in Table 7-19.

1209 The encoding process shall be as follows:

- 1210 1. A group of incoming K information bits $\mathbf{u} = [u_0, u_1, \dots, u_{K-1}]$ are collected and copied to the
 1211 output of the encoder to form a block of systematic code bits.

- 1212 2. N_M-K parity-check bits, $\mathbf{p} = [p_0, \dots, p_{N_M-K-1}]$, are computed using the parity-check matrix
 1213 \mathbf{H} and the information block \mathbf{u} . The resulting coded block $\mathbf{v} = [\mathbf{u} | \mathbf{p}]$ shall satisfy the parity
 1214 check equations $\mathbf{v}\mathbf{H}^T = \mathbf{0}$. Here $\mathbf{0}$ is a zero row vector of dimension N_M-K .
 1215 3. The N_M-K parity check bits \mathbf{p} are copied to the output of the encoder as a block of parity-
 1216 check bits $\mathbf{p} = [p_0, \dots, p_{N_M-K-1}]$ to form the output coded block $\mathbf{v} = [\mathbf{u} | \mathbf{p}] = [v_0, v_1, \dots, v_{N_M-1}]$
 1217 4. The output of the encoder \mathbf{v} is the input to the Puncturing block (see Figure 7-6)
 1218

1219 NOTE – One method of encoding is to determine a systematic generator matrix
 1220 \mathbf{G} from \mathbf{H} such that $\mathbf{G}\mathbf{H}^T = \mathbf{0}$. A K -bit information block $\mathbf{u} = [u_0, u_1, \dots, u_{K-1}]$ can
 1221 be encoded by the systematic generator matrix \mathbf{G} via the operation $\mathbf{v} = \mathbf{u}\mathbf{G}$ to
 1222 become a N_M -bit coded block $\mathbf{v} = [v_0, v_1, \dots, v_{N_M-1}] = [\mathbf{u} | \mathbf{p}]$, where
 1223 $\mathbf{p} = [p_0, \dots, p_{N_M-K-1}]$ are the parity-check bits. Encoding an LDPC code from \mathbf{G}
 1224 can be quite complex. However, the QC-LDPC-BC codes specified here are such
 1225 that very low complexity encoding directly from \mathbf{H} is possible.

1226
 1227

1228 **7.1.3.2.1.1 Puncturing**

1229 Puncturing shall discard some of the coded block bits to achieve a higher coding rate (R).
 1230 Puncturing is applied to both information and parity-check bits. The puncturing block uses
 1231 puncturing patterns specified in Table 7-18. The puncturing patterns are denoted as $\mathbf{pp}_T^{(i)}$, where T is
 1232 the length of the puncturing pattern and i is the number of zeros in the pattern.

1233 **Table 7-18/G.9960 – Puncturing patterns**

	Puncturing pattern
$\mathbf{pp}_{16}^{(0)}$	[1 1 1 1 1 1 1 1 1 1 1 1 1 1 1 1]
$\mathbf{pp}_{16}^{(1)}$	[1 1 1 1 1 1 1 1 1 1 1 1 1 1 1 0]
$\mathbf{pp}_{1152}^{(144)}$	[1 1 ... 1 0 0 ... 0 1 1 ... 1 0 0 ... 0 1 1 ... 1] <small>240 48 720 96 48</small>
$\mathbf{pp}_{5184}^{(648)}$	[1 1 ... 1 0 0 ... 0 1 1 ... 1 0 0 ... 0] <small>216 216 4320 432</small>

1234

1235 NOTE:

1236 The pattern $\mathbf{pp}_{16}^{(0)}$ doesn't result in any coding rate changes and is introduced to
 1237 be consistent with the puncturing notation.

1238

1239

1240 The coded block \mathbf{v} incoming the puncturing block shall be processed using the puncturing pattern
 1241 $\mathbf{pp}_T^{(i)}$ as follows:

1242 For the pattern $\mathbf{pp}_T^{(i)} = [pp_0^{(i)}, \dots, pp_{T-1}^{(i)}]$, the puncturing block shall omit all incoming coded bits
 1243 $v_t, t = 0, \dots, N_M - 1$ for which $pp_{t \bmod T}^{(i)} = 0$. Hence, the resulting output FEC codeword will be
 1244 $\mathbf{v}' = [v'_0, v'_1, \dots, v'_{N_{FEC}-1}]$ with $N_{FEC} \leq N_M$.
 1245

1246 **7.1.3.2.2 FEC encoding parameters**

1247 The FEC encoding scheme shall support encoding parameters specified in Table 7-19.

1248 **Table 7-19/G.9960 – FEC encoding parameters**

	Coding rate, R	Information block size, K	Puncturing pattern, pp	Mother code rate, R_M	FEC codeword size, N_{FEC}
For Header	1/2	PHY _H = 168	$\mathbf{pp}_{16}^{(0)}$	1/2	336
For Payload	1/2	960	$\mathbf{pp}_{16}^{(0)}$	1/2	1920
	1/2	4320	$\mathbf{pp}_{16}^{(0)}$	1/2	8640
	2/3	960	$\mathbf{pp}_{16}^{(0)}$	2/3	1440
	2/3	4320	$\mathbf{pp}_{16}^{(0)}$	2/3	6480
	5/6	960	$\mathbf{pp}_{16}^{(0)}$	5/6	1152
	5/6	4320	$\mathbf{pp}_{16}^{(0)}$	5/6	5184
	16/18	960	$\mathbf{pp}_{16}^{(1)}$	5/6	1080
	16/18	4320	$\mathbf{pp}_{16}^{(1)}$	5/6	4860
	20/21	960	$\mathbf{pp}_{1152}^{(144)}$	5/6	1008
	20/21	4320	$\mathbf{pp}_{5184}^{(648)}$	5/6	4536

1249

1250

1251 **7.1.3.3 Payload encoding**

1252 The functional model of the payload encoder is presented in Figure 7-7. It contains an FEC encoder
 1253 and a Payload Repetition Encoder (PRE) to support robust communication mode (RCM).

1254

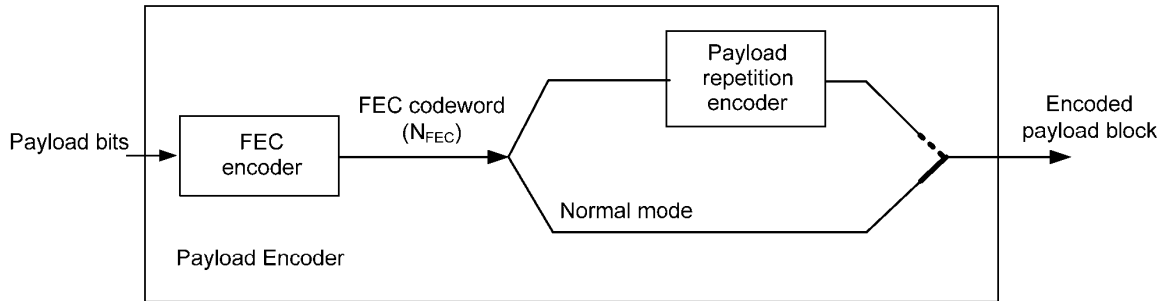

1255
1256

1257 **Figure 7-7/G.9960 – Functional diagram of the Payload Encoder (set to Normal mode)**

1258

1259 The incoming PHY-frame payload shall be divided into sequential blocks of information bits, K bits
1260 per block. Each block of information bits shall be encoded by the FEC, as described in §7.1.3.2.

1261 The valid values of K , the coded block size N_{FEC} , and the coding rate R , are presented in Table 7-19.

1262 The bits of each information block shall be in the same order as they are in the payload; the payload
1263 bit to be transmitted first shall be the first in the corresponding information block.

1264 In normal mode of operation, PRE is disabled. The FEC codewords shall be passed directly to the
1265 output of the Payload Encoder and concatenated into the encoded payload block; their order shall be
1266 the same as the order of corresponding information blocks at the input of the Payload Encoder.

1267 In case of RCM, each FEC codeword is further encoded by the PRE, as described in §7.1.3.3.1. The
1268 PRE-encoded FEC codewords are concatenated into the encoded payload block as defined in
1269 §7.1.3.3.1.

1270 **7.1.3.3.1 Payload repetition encoding**

1271 Payload Repetition Encoder (PRE) shall support the number of repetitions $N_{REP} = 2, 3, 4$ and 6. The
1272 used number of repetitions shall be advertised in the REP field in the PHY-frame header.

1273 The PRE shall operate as follows. Each incoming FEC codeword shall be first copied N_{REP} times.
1274 Each copy shall be divided into S sections, numbered from 0 to $S-1$, with B bits in each section, as
1275 follows:

- 1276 - Bits of the FEC codeword shall be mapped into sections in ascending sequential order; the
1277 bit of the FEC codeword to be transmitted first shall be the first bit (b_0) of Section 0;
- 1278 - If after all bits of the FEC codeword are mapped, the last q bit positions of the last section
1279 remain empty, these position shall be filled by the first q bits of Section 0 in ascending
1280 sequential order.

1281 Mapping of an FEC codeword onto sections is shown in Figure 7-8.

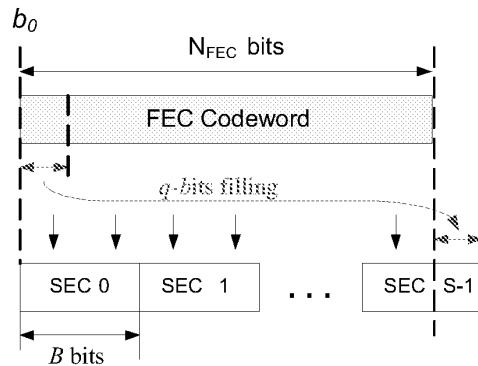

1282

1283

Figure 7-8/G.9960 – Mapping of a FEC codeword onto sections

1284 The number of bits per section shall be $B = \text{floor}(k_P/N_{REP})$, where k_P is the total number of bits that
 1285 can be loaded onto the payload OFDM symbol according to the current BAT. The number of
 1286 sections per FEC codeword is: $S = \text{ceiling}(N_{FEC}/B)$.

1287 If the computed value of S is 1, H consequent FEC codewords may be concatenated. The number of
 1288 sections in this case shall be: $S = \text{ceil}(H \times N_{FEC}/B)$, where H is selected to provide $S > 1$ for the given
 1289 values of N_{FEC} , N_{REP} and k_P . Concatenation of codewords may be applied only when the short FEC
 1290 information block size is used. The total size of the concatenated codewords shall not exceed the
 1291 maximum FEC codeword size.

1292 If the number of FEC codewords in the payload is not a multiple of H , the necessary $z < H$ dummy
 1293 FEC codewords shall be added. These dummy codewords shall be copies of the last FEC codeword
 1294 of the same payload. The values of H (1, 2 and 4) and of z (0 to $H-1$) shall be indicated in the PHY-
 1295 frame header.

1296 The PRE shall output sections sequentially, in groups of S sections. Each group carries a copy of the
 1297 FEC codeword. The number of groups per each FEC codeword is N_{REP} . The order of bits in each
 1298 section shall be the same as these bits appear in the incoming FEC codeword.

1299 The format of the encoded payload block with PRE enabled is presented in Figure 7-9. The total
 1300 number of sections in the encoded payload block is $N_{REP} \times S$.

1301

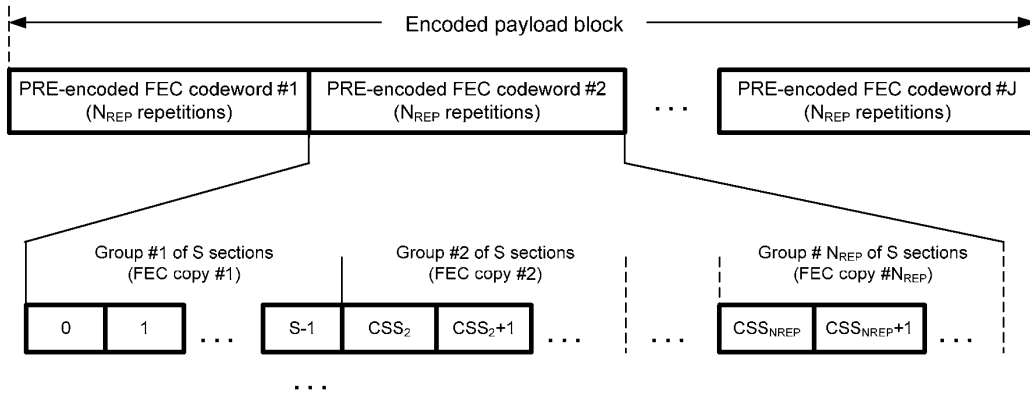

1302

1303

1304

**Figure 7-9/G.9960 – The format of the encoded payload block
(payload consists of J FEC codewords)**

1305

1306 The order of sections in the first group shall be ascending, from 0 to S-1; the order of sections in all
1307 subsequent groups shall be cyclically shifted. The shift is defined by the Cyclic Section Shift (CSS)
1308 vector {0 CSS₂ CSS₃ ... CSS_{N_{REP}}} with a length of N_{REP}, where CSS_L is the sequential number of
1309 the section to be transmitted first in the L-th group of sections. The value of CSS shall be computed
1310 using the following rule:

1311 For N_{REP} = 2:

1312 if (S mod 2) = 0 CSS:= {0,1};

1313 else CSS:= {0,0};

1314 For N_{REP} = 4:

1315 if (S mod 4) = 0 CSS:= {0,1,2,3};

1316 else if (S mod 2) = 0 CSS:= {0,0,1,1};

1317 else CSS:= {0,0,0,0};

1318 For N_{REP} = 3:

1319 if (S mod 3) = 0 CSS:= {0,1,2};

1320 else CSS:= {0,0,0};

1321 For N_{REP} = 6:

1322 if (S mod 6) = 0 CSS:= {0,1,2,3,4,5};

1323 else if (S mod 3) = 0 CSS:= {0,0,1,1,2,2};

1324 else if (S mod 2) = 0 CSS:= {0,0,0,1,1,1};

1325 else CSS:= {0,0,0,0,0,0};

1326

1327 NOTE: As an example, with CSS = 3 for a group of S = 4 sections, these sections
1328 will be transmitted in the following order: 3, 0, 1, 2. The first group of sections,
1329 for comparison, is transmitted: 0, 1, 2, 3.

1330

1331 **7.1.3.4 Header encoder**

1332 The functional model of the header encoder is presented in Figure 7-10. It contains an FEC encoder
 1333 and a Header Repetition Encoder (HRE).

1334

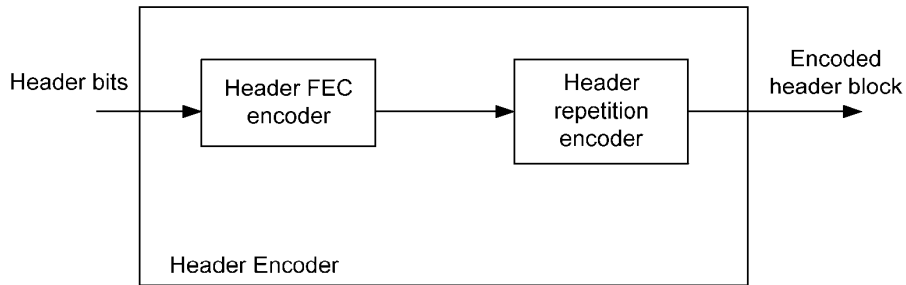

1335

1336 **Figure 7-10/G.9960 – Functional diagram of the Header Encoder**

1337 The bits of the PHY-frame header shall input the Header FEC encoder in their original order and
 1338 encoded as described in §7.1.3.2. The size of the FEC codeword and the coding rate of the Header
 1339 FEC encoder are described in Table 7-19.

1340

1341 The FEC codeword enters the HRE. The HRE shall operate as follows:

- 1342 - The FEC codeword shall be first copied M times, where $M = \text{ceiling}(D \times k_H / N_{FEC})$, k_H is the
 1343 number of bits to be loaded onto the OFDM symbol carrying the header, and D is the
 1344 number of symbols to be used for header transmission
- 1345 - The encoded header block shall be formed by concatenation of M copies of the header FEC
 1346 encoder output. As each codeword is cascaded to one another, the bits (b_i) within a
 1347 codeword shall be cyclically shifted by 2 bits as follows:
 - 1348 ○ The 1st FEC codeword copy shall be formed as $\{b_0, b_1, \dots, b_{N_{FEC}-2}, b_{N_{FEC}-1}\}$.
 - 1349 ○ The 2nd FEC codeword copy shall be formed as $\{b_2, b_3, \dots, b_{N_{FEC}-1}, b_0, b_1\}$.
 - 1350 ○ The 3rd FEC codeword copy shall be formed as $\{b_4, b_5, \dots, b_{N_{FEC}-1}, b_0, b_1, b_2, b_3\}$.
 - 1351 ○ ...
 - 1352 ○ The M^{th} FEC codeword copy, where $M > 3$, shall be formed as $\{b_{(2 \times M - 2)}, b_{(2 \times M - 1)}, \dots,$
 1353 $b_{N_{FEC}-1}, b_0, b_1, \dots, b_{(2 \times M - 4)}, b_{(2 \times M - 3)}\}$.

1354 Valid values of D are either 1 or 2 (with $D=1$ being the default).

1355 NOTE: Since the coding rate used for header encoding is $1/2$, the number of bits in
 1356 the FEC codeword is always even, and the number of bits in the encoded header
 1357 block is even.

1358

1359 **7.1.3.5 Segmentation into symbol frames**

1360 The encoded payload block from the output of Payload encoder and the encoded header block from
 1361 the output of the Header encoder shall be segmented into symbol frames. The maximum number of
 1362 bits in the symbol frame shall not exceed the values of k_P for payload symbol frames and k_H for

1363 header symbol frame. Payload and header symbol frames shall be passed to the PMD, as described
1364 in Figure 7-4.

1365 **7.1.3.5.1 Payload segmentation**

1366 The encoded payload block shall be segmented into one or more symbol frames.

1367 In normal mode, the first symbol frame shall contain the first k_P bits of the encoded payload block,
1368 the second frame shall contain the second k_P bits of the encoded payload block and so on, until the
1369 last symbol frame. If the remaining number of bits in the encoded payload is less than k_P , the last
1370 symbol frame shall remain incomplete. The unused sub-carriers of the OFDM symbol
1371 corresponding to the last symbol frame shall be modulated by a pseudo-random sequence of bits, as
1372 described in §7.1.4.2.6.

1373 In RCM, the first symbol frame shall contain the first N_{REP} sections of the encoded payload block,
1374 the second frame shall contain the second N_{REP} sections of the encoded payload block, and so on,
1375 until the last symbol frame. If the number of bits in N_{REP} sections is less than k_P , symbol frames
1376 shall remain incomplete. The unused sub-carriers of the corresponding OFDM symbols shall be
1377 modulated by a pseudo-random sequence of bits, as described in §7.1.4.2.6.

1378 **7.1.3.5.2 Header segmentation**

1379 The encoded header block shall be segmented into D symbol frames ($D = 1$ or 2).

1380 The first k_H bits of the encoded header block shall be mapped into the first symbol frame.

1381 If $D = 1$, the rest of the bits of the encoded header block shall be discarded.

1382 If $D = 2$, the second k_H bits shall be taken with an offset of half an FEC block, i.e., starting from the
1383 bit number $N_{FEC}/2$ of the encoded header block, and mapped into the second symbol frame. The rest
1384 of the bits in the encoded header block shall be discarded.

1385 **7.1.3.6 Probe frame**

1386 The Probe frame is intended for the channel assessment procedure. The header of the Probe frame
1387 shall be as defined in §7.1.2.3. The payload of the Probe frame (at the δ -reference point) shall
1388 contain a number of symbol frames with no data (all supported sub-carriers (SSCs) are inactive sub-
1389 carriers (ISCs)) as described in field PRBSYM in §7.1.2.3.2.6.1. The number of the symbols shall
1390 be indicated via the PRBSYM field in §7.1.2.3.2.6.1. The inactive sub-carriers of the corresponding
1391 OFDM symbols shall be modulated by a pseudo-random sequence of bits, as described in
1392 §7.1.4.2.6.

1393 The number of symbol frames (and OFDM symbols) in the Probe frame is indicated in the PHY-
1394 frame header.

1395

1396 **7.1.4 Physical medium dependent (PMD) sub-layer**

1397 The functional model of the PMD is presented in Figure 7-11. In the transmit direction, the Tone
1398 mapper divides the incoming symbol frames of the Header and Payload into groups of bits and
1399 associates each group of bits with a specific sub-carrier onto which this group shall be loaded, as
1400 specified in §7.1.4.2. The constellation encoder converts every group of the incoming bits into
1401 complex numbers which are, respectively, the real and imaginary part of the constellation point on
1402 which the particular group of bits is loaded for this subcarrier. The constellation mapping process is
1403 described in §7.1.4.3.1. The unused sub-carriers are modulated by a pseudo-random bit sequence
1404 generated as described in §7.1.4.2.6.

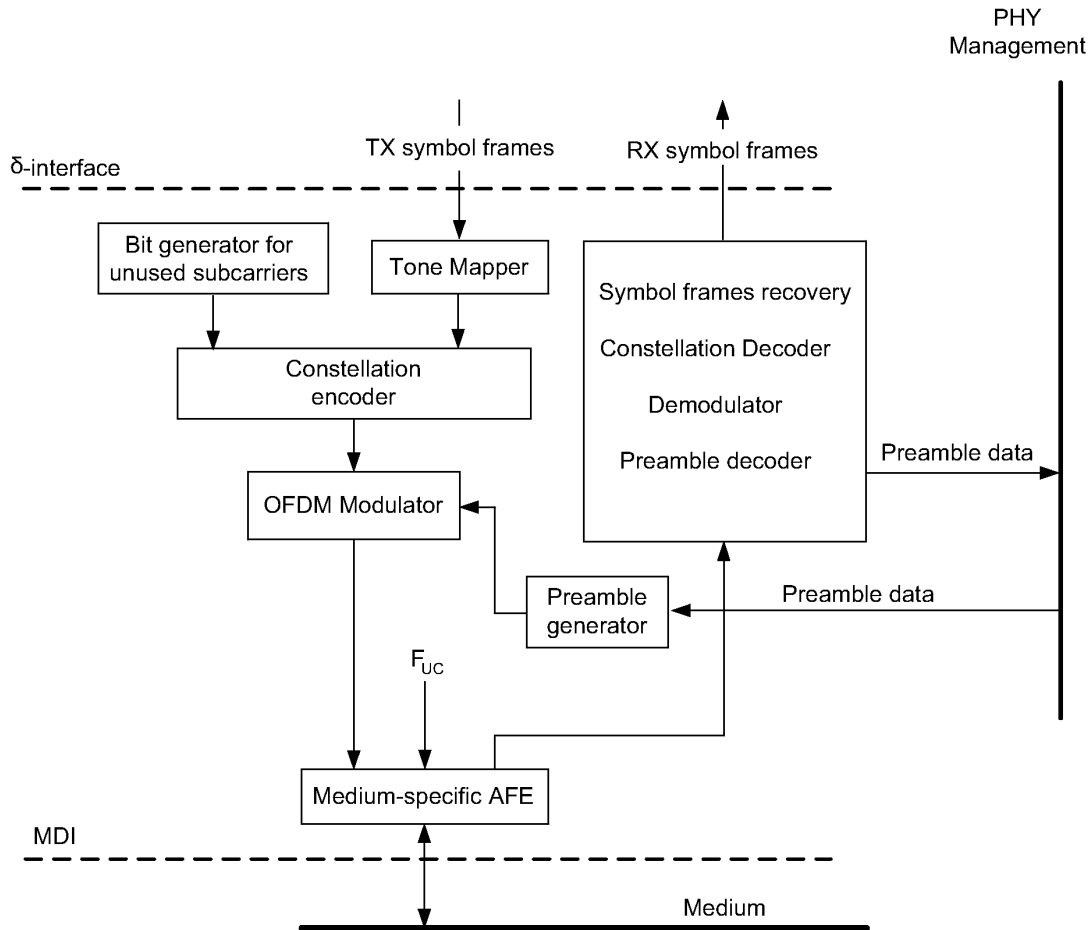

1405

1406

Figure 7-11/G.9960 – Functional model of the PMD

1407 The OFDM modulator (§7.1.4.4) converts the stream of the N complex numbers at its input into the
 1408 stream of N time-domain samples. After adding the Preamble, the transmit signal is up-shifted by
 1409 the center frequency F_{US} or, for RF applications, by center frequency F_{UC} to fit the required
 1410 spectrum of the transmit signal. Parameters of the Preamble (§7.1.4.5) are determined by the PHY
 1411 management and depend on the type of the transmitted PHY frame.

1412 Frames are output onto the medium with inter-frame gaps the details of which are for further study.

1413 In the receive direction, the frames incoming from the medium are demodulated and decoded. The
 1414 recovered symbol frames are transferred to the PMA via δ -interface. The preamble is processed and
 1415 preamble data are passed to the PHY management entity.

1416 **7.1.4.1 Sub-carrier spacing and logical indexing**

1417 The sub-carrier spacing F_{SC} is the frequency spacing between any two adjacent sub-carriers. Valid
 1418 values of sub-carrier spacing are presented in Table 7-28, with a tolerance of ± 50 ppm.

1419 The logical index is the index for loading data on sub-carriers. The logical index may be different
 1420 from the input order to the IDFT used in §7.1.4.4.1. The order in which constellation points

1421 associated with particular sub-carriers are input to the IDFT shall be in accordance with the
1422 following indexing rules.

1423 The logical index of sub-carriers shall be from $i = 0$ to $i = N - 1$ using one of the following two
1424 rules:

1425 Rule #1: The sub-carriers with all logical indices from $i = 0$ to $i = N - 1$ shall be centered at
1426 frequencies $f = F_{US} - (N/2 - i) \times F_{SC}$.

1427 Rule #2: The sub-carriers with even logical indices from $i = 0$ to $i = N - 2$ shall be centered at
1428 frequencies $f = F_{UC} + F_{US} + (i/2) \times F_{SC}$ while those with odd logical indices from $i = 1$ to $i =$
1429 $N - 1$ shall be centered at frequencies $f = F_{UC} + F_{US} - ((i+1)/2) \times F_{SC}$.

1430 Logical indexing rules shall be applied in accordance with the Domain Type and the bandplan, as
1431 specified in Table 7-30, Table 7-33, and Table 7-37.

1432 Not all sub-carriers may always be used for data transmission; some of them have to be switched
1433 off in special circumstances. Others may be only used with reduced power. The latter functions are
1434 performed by tone masking and gain scaling (§7.1.5.1, 7.1.5.3).

1435 NOTE – The particular sub-carriers used for data transmission between two
1436 particular nodes depend on channel characteristics, such as loop attenuation and
1437 noise, and on the specific spectrum-use requirements, such as notching of amateur
1438 radio bands; some sub-carriers may be subject for PSD reduction, e.g., at high and
1439 low frequencies to share the medium with other services.

1440 NOTE – In case of a non-RF application, the value of F_{UC} is zero. For baseband
1441 applications (the lowest sub-carrier frequency is zero), the value of F_{US} should be:
1442 $F_{US} = F_{SC} \times N/2$.

1443

1444 7.1.4.2 Tone Mapper

1445 The tone mapper determines the number of bits to be loaded on each sub-carrier and the value of
1446 gain on each sub-carrier. The ability of bit loading depends on the type of the sub-carrier.

1447 7.1.4.2.1 Summary of sub-carrier types

1448 For the purpose of tone mapping, the following types of sub-carriers are defined.

1449 1. Masked sub-carriers (MSC) are those on which transmission is not allowed, i.e., the gain on this
1450 sub-carrier shall be set to zero. Two types of MSC are defined:

1451 - Permanently masked sub-carriers (PMSC) – those that are never allowed for transmission.
1452 The list of PMSC, also called PMSC mask, depends on the media type and is defined by
1453 limited PSD mask, §7.2. Data bits are never mapped on PMSC.

1454 - Regionally masked sub-carriers (RMSC) – those that are not allowed for data transmission
1455 in some regions, while may be allowed in other regions. The list of RMSC forms a RMSC
1456 mask, which depends on the type of media and on the region/application. The number of
1457 RMSC, $\#RMSC = \#MSC - \#PMSC$.

1458 2. Supported sub-carriers (SSC) are those on which transmission is allowed under restrictions of the
1459 relevant PSD mask. The number of SSC, $\#SSC = N - \#MSC$. The following types of SSC are
1460 defined:

1461 - Active sub-carriers (ASC) – those that have loaded bits ($b \geq 1$) for data transmission. ASC
 1462 are subject to constellation point mapping, constellation scaling and constellation scrambling
 1463 as described in §7.1.4.3. Data bits shall be mapped on ASC as described in §7.1.4.2.2.
 1464 - Inactive sub-carriers (ISC) – those that don't have any data bits loaded (e.g., because SNR is
 1465 low, or by any other reason). The number of ISC, #ISC = #SSC – #ASC. ISC can be used for
 1466 measurement purposes or other auxiliary purposes. ISC are subject for transmit power
 1467 shaping. The signals transmitted on ISC are defined in §7.1.4.2.6.
 1468 All sub-carriers with frequencies between the supported sub-carrier with the lowest frequency and
 1469 the supported sub-carrier with the highest frequency are also called “in-band sub-carriers”.

1470 **7.1.4.2.2 Bit Allocation Tables (BAT)**

1471 Tone mapping is defined by a Bit Allocation Table (BAT) that associates sub-carrier indexes with
 1472 the number of bits to be loaded on the sub-carrier. The order of sub-carrier indexes in BAT shall be
 1473 numerical, from the smallest index to the largest index. Bits of the TX symbol frame shall be loaded
 1474 on the sub-carriers in the order of indexes in BAT, according to subcarrier indexing defined in
 1475 §7.1.4.1.

1476 The BATs used by the node in the particular PHY frame shall be indicated to the receiving node(s)
 1477 in the TPN field of the PHY-frame header, as described in §7.1.2.3, using a BAT identifier
 1478 (BAT_ID). Up to 32 BAT with BAT_ID values in the range from 0 to 31 can be defined. One or
 1479 more BAT_ID can be assigned for each destination (per unicast or multicast DID). The assignment
 1480 of BAT_ID shall be as described in Table 7-20.

1481

Table 7-20/G.9960 – Assignment of BAT_ID

BAT_ID	Type of BAT	Reference
0	Pre-defined, Type 0	§7.1.4.2.2.1
1	Pre-defined, Type 1	
2	Pre-defined, Type 2	
3	Pre-defined, Type 3	
4-15	Reserved for pre-defined BATs	
16-31	Reserved for runtime BATs	§7.1.4.2.2.2

1482

1483 Every node shall support at least pre-defined BATs of Type 0 and Type 1. Support of other BATs is
 1484 profile-dependent and shall be as described in Table 7-26.

1485 **7.1.4.2.2.1 Pre-defined BATs**

1486 The following pre-defined BATs are defined.

- 1487 1. Pre-defined BAT Type 0: Uniform 2-bit loading on all sub-carriers except the PMSC set.
- 1488 2. Pre-defined BAT Type 1: Uniform 1-bit loading on all sub-carriers except the PMSC set.
- 1489 3. Pre-defined BAT Type 2: Uniform 2-bit loading on a particular selected ASC set.
- 1490 4. Pre-defined BAT Type 3: Uniform 1-bit loading on a particular selected ASC set.

1491 NOTE: Pre-defined BAT Type 0 and Type 1 may be used when channel
 1492 characteristics are unknown (i.e., no knowledge is available on whether particular
 1493 tones could be loaded bits or not).

1494 NOTE: Pre-defined BATs that are implemented using a particular ASC set (e.g.,
1495 Type 2) are always associated with a reference, such as a runtime BAT, which
1496 defines this ASC set. The coding is for further study.

1497 **7.1.4.2.2 Runtime BATs**

1498 A runtime BAT associates indices of SSCs with the number of bits to be loaded on each sub-carrier.
1499 The subset of indices in the BAT with the number of loaded bits $b > 0$ identifies the ASC. Runtime
1500 BAT can be defined by the receiving node (receiver-defined BAT) or selected by the transmitting
1501 node (transmitter-determined BAT) for a specific unicast or multicast channel. Runtime BATs shall
1502 be communicated from the node which generates the BAT to the peer (e.g., a node sourcing
1503 multicast transmission to several other nodes will communicate the BAT to all receiving nodes prior
1504 to sending data).

1505 The number of bits loaded on any sub-carrier shall not exceed the maximum number of bits allowed
1506 (see §7.1.4.3). The number of bits shall also meet the bit loading capabilities of the communicating
1507 nodes, as advertised by them prior to communication.

1508 **7.1.4.2.3 Transmitter-determined and receiver-determined mapping**

1509 Two types of tone mapping are defined: transmitter-determined and receiver-determined. With
1510 transmitter-determined mapping, the BAT is defined by the transmitter and shall be either a pre-
1511 defined BAT or it shall be communicated to all destination nodes prior to transmission. With
1512 receiver-determined mapping, the BAT is defined by the receiver of the destination node and
1513 communicated back to the transmitter.

1514 For unicast transmission, the node shall use either one of the pre-defined BATs (transmitter-
1515 determined) or a BAT defined by the receiver of the destination node for the PHY frame. For
1516 multicast transmission both pre-defined BATs (transmitter determined) and runtime BATs can be
1517 used. If a runtime BAT is used, it shall be defined by the node sourcing the multi-cast (transmitter-
1518 determined); this node shall generate the BAT and communicate it to all multi-cast destinations.

1519 The BAT communication protocol is for further study.

1520 A node shall support both transmitter-determined and receiver-determined types of mapping, with
1521 the minimum number of simultaneously supported BAT depends on the profile. The definition of
1522 profiles is for further study.

1523

1524 **7.1.4.2.4 BAT with sub-carrier grouping**

1525 A node shall be capable to define any runtime BAT using sub-carrier grouping of $G = 1$ (no
1526 grouping), 2, 4, 8, and 16 sub-carriers with subsequent frequencies. The default value of $G = 1$. If
1527 grouping is used ($G > 1$), all sub-carriers of the same group shall use the same bit loading. The first
1528 group shall include G sub-carriers in ascending order of subcarrier indexes defined in §7.1.4.1. If a
1529 group includes sub-carriers that are masked (e.g., MSC) or extends beyond the applicable sub-
1530 carrier set, the node shall apply the bit loading assigned for this group only to the applicable sub-
1531 carrier set.

1532 The group index G shall be indicated when the BAT is communicated, details of which are for
1533 further study.

1534

1535 **7.1.4.2.5 Special mappings**

1536 **7.1.4.2.5.1 Tone mapping for PHY-frame header**

1537 The PHY-frame header shall use a uniform loading of 2 bits per sub-carrier on all sub-carriers
1538 except the PMSC set.

1539 **7.1.4.2.5.2 Tone mapping for RCM**

1540 Payload transmission in robust communication mode RCM shall use pre-defined BAT Type 0.

1541 **7.1.4.2.5.3 Tone mapping for probe frame**

1542 The payload of the Probe frame shall be modulated using a uniform loading of 1 bit per sub-carrier
1543 on all SSC set. For Probe frames, ISC = SSC.

1544

1545 **7.1.4.2.6 Modulation of unloaded sub-carriers**

1546 Supported sub-carriers (SSC) that are not loaded with payload bits or that are partially loaded with
1547 payload bits shall be loaded with a pseudo-random sequence defined by the Linear Feedback Shift
1548 Register (LFSR) generator with the polynomial $p(x)=x^{23}+x^{18}+1$ shown in Figure 7-12. The LFSR
1549 generator shall be initialized to all ones (0x7FFFFFFF) at the beginning of the first payload OFDM
1550 Symbol. It shall be advanced by two bits for each sub-carrier (for both SSC and MSC).

1551

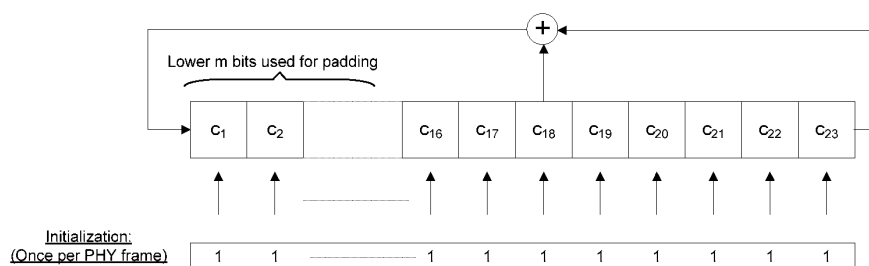

1552

Figure 7-12/G.9960 – LFSR for modulation of unloaded and partially loaded sub-carriers

1553 The modulation of sub-carriers that are not loaded with payload bits shall be as follows:

- 1554 1) Starting at the beginning of the first payload OFDM symbol, each sub-carrier from the ISC
1555 set shall be modulated with the two bits which are the LSBs of the LFSR, c_1 , and c_2 using 2-
1556 bits constellation mapping defined in §7.1.4.3.1.1 (c_1 is transmitted first). If a special
1557 channel-estimation symbol is used after the PHY-header, it shall be considered as a payload
1558 symbol for this purpose. All SSC of a channel-estimation symbol are ISC.
- 1559 2) In every OFDM symbol of payload, if the number of bits in the symbol frame doesn't fill the
1560 entire symbol, the bits from the LFSR shall be used to fill the remainder of the symbol
1561 frame, by taking the sequential groups of m LSBs of the LFSR and mapping them onto the
1562 remaining sub-carriers so that LSB of LFSR is transmitted first and in the order defined by
1563 the current BAT, where m is the number of bits allocated for that sub-carrier by the BAT.
1564 For the first padded sub-carrier, if n bits of the m loaded bits are data bits, these n data bits
1565 shall be loaded as the LSBs of the group of bits mapped on the constellation point, and the
1566 $m-n$ bits of the LFSR shall be used as the MSBs of the group of bits mapped on the
1567 constellation point starting from LSB of LFSR.

1568 3) In the case of a Probe frame, starting at the beginning of the first payload OFDM symbol,
 1569 each sub-carrier from the ISC set shall be modulated with the one bit, which is the LSB of
 1570 the LFSR, c_1 , using 1-bit constellation mapping defined in §7.1.4.3.1.2.

1571 **7.1.4.3 Constellation Encoder**

1572 **7.1.4.3.1 Constellation mapping**

1573 Constellation mapping associates every group of bits loaded onto a sub-carrier, with the values of I
 1574 (in-phase component) and Q (quadrature component) of a constellation diagram. Each incoming
 1575 group of b bits $\{d_{b-1}, d_{b-2}, \dots, d_0\}$ shall be associated with a specific values of I and Q computed as
 1576 described in this section.

1577 Each group of bits $\{d_{b-1}, d_{b-2}, \dots, d_0\}$ shall be mapped onto the constellation mapper with the LSB
 1578 bit, d_0 , first.

1579 **7.1.4.3.1.1 Constellations for even number of bits**

1580 If the number of bits, b , loaded onto the sub-carrier is even (2, 4, 6, 8, 10, 12), square-shaped
 1581 constellations with mappings described in this section shall be used. Support of all the specified
 1582 even order constellations (2, 4, 6, 8, 10 and 12) shall be mandatory at both the transmitter and the
 1583 receiver. With square-shaped constellations 2^b constellation points are set as a square, and 2^{b-2}
 1584 points reside in each quadrant with odd values (positive or negative) of I and Q .

1585 Constellation and mapping for $b = 2$ shall be as presented in Figure 7-13 and described in Table 7-
 1586 21.

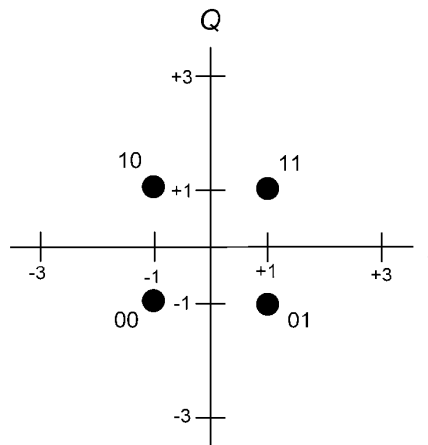

Figure 7-13/G.9960 - Constellation and mapping for $b = 2$

Table 7-21/G.9960 - Mapping for $b = 2$ (QPSK)

Bit d_0	I	Bit d_1	Q
0	-1	0	-1
1	1	1	1

1591

1592 Constellation mapping for $b = 4$ shall be as described in Table 7-22. The first quadrant of the
 1593 mapping is presented in Figure 7-14.

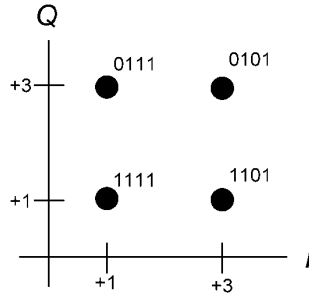

1594

1595 **Figure 7-14/G.9960 – Constellation and mapping for $b = 4$ (first quadrant)**

1596

1597

Table 7-22/G.9960 - Mapping for $b = 4$

Bits [d_1d_0]	I	Bit [d_3d_2]	Q
00	-3	00	-3
10	-1	10	-1
11	1	11	1
01	3	01	3

1598

1599 Constellation mappings for even values of $b \geq 4$ shall be derived by the following steps.

1600 1. Divide the incoming group of b bits into two equal sub-groups, so that $b/2$ LSBs form the first
 1601 sub-group (I -group) and $b/2$ MSBs form the second sub-group (Q -group); both sub-groups are
 1602 incoming LSB (which are d_0 and $d_{b/2}$, respectively) first.

1603 2. Compute values of I and Q for the incoming group $\{d_{b-1}, d_{b-2}, \dots, d_0\}$ as:

1604 $I = \text{sgn}_I \times \text{val}_I$

1605 $Q = \text{sgn}_Q \times \text{val}_Q$

1606 The values of sgn and val shall be computed as presented in Table 7-23 using bits of I -group to
 1607 compute I and bits of Q -group to compute Q .

1608

Table 7-23/G.9960 – Computation rule for *sgn* and *val*

<i>I</i> - component	<i>Q</i> - component
- compute $sgn_I = 2 \times d_0 - 1$	- compute $sgn_Q = 2 \times d_{b/2} - 1$
- compute $val_I = I_{b-2} - 2^{b/2-1} $	- compute $val_Q = Q_{b-2} - 2^{b/2-1} $
NOTES: 1. I_{b-2} and Q_{b-2} are the values of <i>I</i> and <i>Q</i> computed for the incoming (<i>b</i> -2)-bit group $\{d_{b-1}, d_{b-2}, \dots, d_{b/2+1}, d_{b/2-1}, \dots, d_1\}$, i.e., with removed d_0 and $d_{b/2}$. 2. The values of <i>I</i> and <i>Q</i> for 2-bit groups shall be as presented in Table 7-21 3. $ X $ is the absolute value of X	

1609

1610 **7.1.4.3.1.2 Constellations for odd number of bits**

1611 If the number of bits, *b*, loaded onto the sub-carrier is odd (1, 3, 5, 7, 9, 11), constellations with
 1612 mappings described in this section shall be used. The support of all the specified odd order
 1613 constellations (1, 3, 5, 7, 9 and 11) shall be mandatory at the transmitter. The support of all the
 1614 specified odd order constellations with $b \geq 5$, shall be optional at the receiver.

1615 For multi-cast transmission, odd constellations with $b \geq 5$ shall not be used.

1616 Constellation and mapping for $b = 1$ shall be as presented in Figure 7-15.

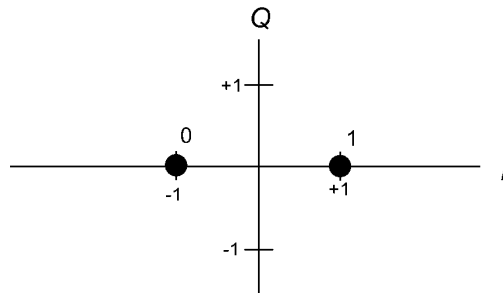

1617

1618 **Figure 7-15/G.9960 - Constellation shape and mapping for $b = 1$**

1619 Constellation and mapping for $b = 3$ shall be as presented in Figure 7-16.

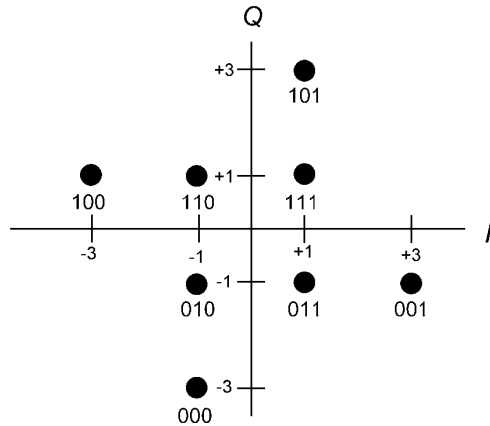

1620

1621

Figure 7-16/G.9960 - Constellation and mapping for $b = 3$

1622 For $b > 3$ cross-shaped constellations shall be used. First, 2^b constellation points shall be set as a
 1623 rectangle, with $M_I = 2^{B1}$ columns (M_I points on the I -axis) and $M_Q = 2^{B2}$ rows (M_Q points on the
 1624 Q -axis), where $B1 = \text{ceiling}(b/2)$ and $B2 = \text{floor}(b/2)$. The mapping of these points shall be
 1625 computed using the following steps.

1626 1. Divide the incoming group of bits into two sub-groups, so that $B1$ LSBs form the first sub-group
 1627 (I -group) and $B2$ MSBs form the second sub-group (Q -group); both sub-groups are incoming LSB
 1628 (which are d_0 and d_{B2+1} , respectively) first.

1629 2. Compute values of I and Q of a rectangular constellation for the incoming group $\{d_{b-1}, d_{b-2}, \dots$
 1630 $d_0\}$ as:

1631 $I = \text{sgn}_I \times \text{val}_I$

1632 $Q = \text{sgn}_Q \times \text{val}_Q$

1633 The values of sgn and val shall be computed as presented in Table 7-24 using bits of I -group to
 1634 compute I and bits of Q -group to compute Q .

1635

1636

Table 7-24/G.9960 – Computation rule for sgn and val

I - component	Q - component
- compute $\text{sgn}_I = 2 \times d_0 - 1$	- compute $\text{sgn}_Q = 2 \times d_{B1} - 1$
- compute $\text{val}_I = I_{2 \times B1} $	- compute $\text{val}_Q = Q_{2 \times B2} $
NOTES: 1. $I_{2 \times B1}$ is the value of I for $(2 \times B1)$ -bit group $\{0 d_{b-1}, d_{b-2}, \dots d_0\}$ computed as defined in Table 7-23. 2. $Q_{2 \times B2}$ is the value of Q for $(2 \times B2)$ -bit group $\{d_{b-1}, d_{b-2}, \dots d_1\}$ computed as defined in Table 7-23. 3. $ X $ is the absolute value of X	

1637

1638 3. Transform $s = (M_I - M_Q)/4$ columns of constellation points in each quadrant having highest
 1639 absolute values of I (positive or negative) into rows of Q by changing their $\{I, Q\}$ coordinates to $\{I'$
 1640 $Q'\}$ in the following way:

- 1641 • $|Q'| = |I| - 2s$, and $\text{sign}(Q') = \text{sign}(I)$;
- 1642 • $|I'| = M_Q - |Q|$, and $\text{sign}(I') = \text{sign}(Q)$.

1643 The described transformation of $\{I, Q\}$ coordinates for $b = 7$ is presented in Figure 7-17 with $B1 =$
 1644 4 and $B2 = 3$ (the MSB and LSB in Figure 7-17 are separated by “/”).

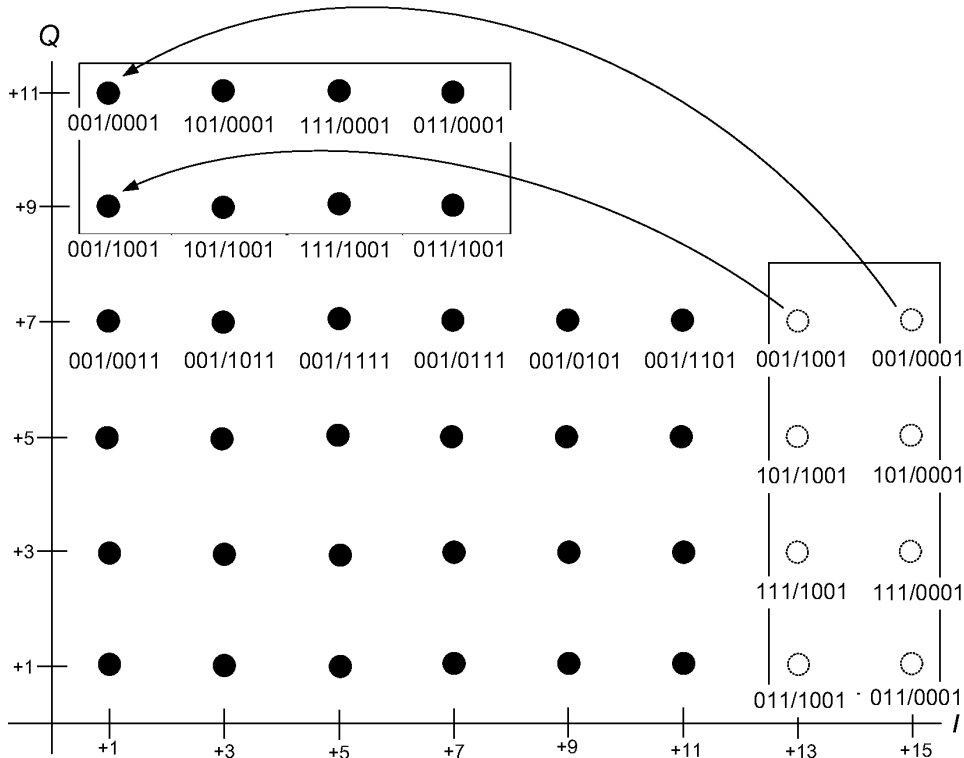

1645

1646 **Figure 7-17/G.9960 - Transformation of rectangular constellation into cross-shaped**
 1647 **constellation for $b = 7$ (first quadrant)**

1648

1649 **7.1.4.3.2 Constellation point scaling**

1650 Each constellation point (I, Q) , corresponding to the complex value $I + jQ$ at the output of the
 1651 constellation mapper, shall be scaled by the power-normalization factor $\chi(b)$, the frequency-domain
 1652 spectrum shaping coefficient tss , and the gain adjuster g :

1653
$$Z = \chi(b) \times tss \times g \times (I + jQ).$$

1654

1655 **7.1.4.3.2.1 Power normalization factor**

1656 The values (I, Q) for each constellation point of each sub-carrier shall be scaled such that all
 1657 constellations, regardless of their size, have the same average power. The required scaling, $\chi(b)$, for
 1658 a sub-carrier with b -bit loading depends only on the value of b and shall be set as presented in Table
 1659 7-25.

1660 **Table 7-25/G.9960 – Power normalization factor**

Number of bits loaded (b)	Scaling factor (χ) (linear scale)
1	1
2	$1/\sqrt{2}$
3	$1/\sqrt{6}$
4	$1/\sqrt{10}$
5	$1/\sqrt{20}$
6	$1/\sqrt{42}$
7	$1/\sqrt{82}$
8	$1/\sqrt{170}$
9	$1/\sqrt{330}$
10	$1/\sqrt{682}$
11	$1/\sqrt{1322}$
12	$1/\sqrt{2730}$

1661

1662 **7.1.4.3.2.2 Transmit spectrum shaping**

1663 Frequency-domain spectrum shaping of the transmit signal is achieved by a scaling factor tss
 1664 defined for each sub-carrier. The tss values are set by the transmitter and shall be in the range
 1665 between 0 and 1 (linear) in steps of 1/1024. The tss values shall be set such that the highest value
 1666 across all sub-carriers is 1. Smaller values of tss provide attenuation and the value $tss = 0$
 1667 corresponds to no power transmitted on the particular sub-carrier. If no spectrum shaping is applied,
 1668 the tss values shall be equal to 1 for all sub-carriers. The values of tss_i are relevant only for sub-
 1669 carriers that are actually transmitted (not masked), and shall be ignored for masked sub-carriers (see
 1670 §7.1.5.3).

1671 The communication protocol for tss is for further study.

1672 **7.1.4.3.2.3 Gain adjustment**

1673 The gain adjuster g is intended for fine gain adjustment of the power transmitted at a particular sub-
 1674 carrier, which may be used to equalize the SNR margin over all sub-carriers.

1675 The value of gain adjuster shall be set to 1. Other values are left for further study.

1676 **7.1.4.3.3 Constellation Scrambler**

1677 The phase of constellation points generated by the Constellation Mapper shall be shifted in
 1678 accordance with the pseudo-random sequence generated by a Linear Feedback Shift Register
 1679 (LFSR) generator, as shown in Figure 7-18.

1680

1681

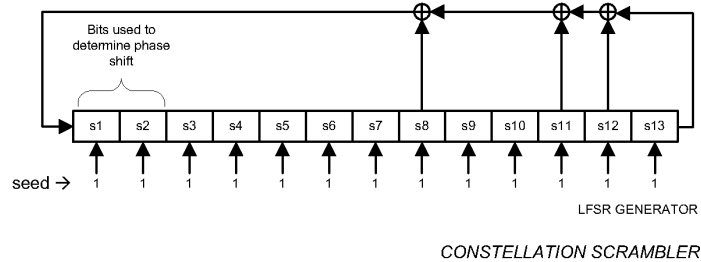

1682

1683

Figure 7-18/G.9960 – Constellation scrambler

1684

1685 The LFSR generator shall implement the polynomial $g(x) = x^{13} + x^{12} + x^{11} + x^8 + 1$ and shall be
 1686 advanced by 2 bits for each sub-carrier. The two LSB's of the register shall be taken to determine
 1687 the phase shift as shown in Table 7-26. The shift of the LFSR for subcarrier index k will be $2k$.

1688

1689

Table 7-26/G.9960 – Constellation phase shift versus LFSR output

LFSR OUTPUT		PHASE SHIFT (rad)
S2	S1	
0	0	0
0	1	$\pi/2$
1	0	π
1	1	$3\pi/2$

1690

1691 The LFSR generator shall be initialized with the seed 0x1FFF for each OFDM symbol. The
 1692 constellation scrambling shall be applied to the PHY-frame header and all payload symbols.

1693

1694 **7.1.4.4 OFDM modulator**

1695 The OFDM modulator consists of the following major parts: IDFT, cyclic extension, windowing,
 1696 overlap and add, and frequency up-shift. The incoming signal to the modulator at the l -th OFDM
 1697 symbol in the present frame for a single sub-carrier, with index i , is the real and imaginary parts of
 1698 the value $Z_{i,l}$ generated by the Constellation encoder as described in §7.1.4.3.2 (for symbols of the
 1699 header and the payload) or by Preamble Generator as described in §7.1.4.5.2.1 (for symbols of the
 1700 preamble). Time-domain samples generated by the IDFT, after adding the cyclic prefix and
 1701 windowing, are frequency up-shifted to the center frequency F_{US} . The functional diagram of

1702 OFDM modulator is presented in Figure 7-19. RF up-converter facilitates G.9960 operation in RF
 1703 frequency range.

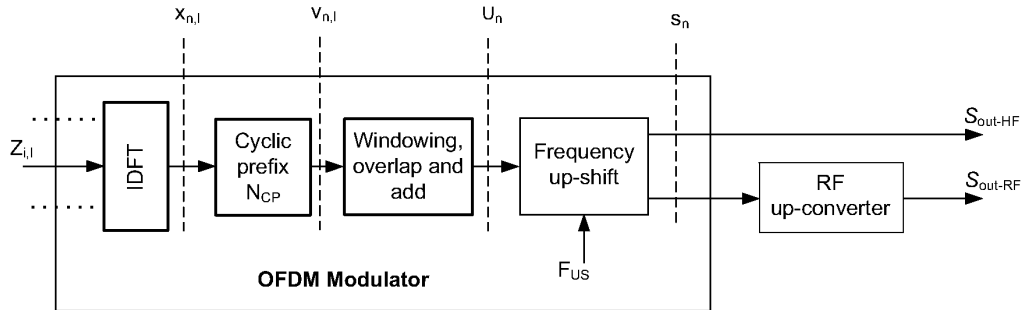

1704
 1705

1706 **Figure 7-19/G.9960 – Functional model of the OFDM modulator**

1707 The presented functional diagram and other figures presented in this section do not imply any
 1708 specific implementation. All aspects of signal processing used in the modulator shall comply with
 1709 equations and textual descriptions.

1710

1711 **7.1.4.4.1 IDFT**

1712 The IDFT converts the streams of the N complex numbers $Z_{i,l}$ at its inputs into the stream of N
 1713 complex time-domain samples $x_{n,l}$. The input numbers represent the N mapped blocks of data,
 1714 where i -th block of data represents the relative complex value $Z_{i,l} = \text{Re}(Z_{i,l}) + j\text{Im}(Z_{i,l})$ of the i -th
 1715 modulated sub-carrier of the OFDM signal, where $i = 0, 1, \dots, N-1$ is the sub-carrier index and l is
 1716 the sequential number of the OFDM symbol within the current frame, excluding the preamble. The
 1717 conversion shall be performed in accordance with the equation:

1718
$$x_{n,l} = \sum_{i=0}^{N-1} \exp\left(j \cdot 2\pi \cdot i \frac{n}{N}\right) \cdot Z_{i,l} \quad \text{for } n = 0 \text{ to } N-1, \quad l = 0 \text{ to } M_F - 1.$$

1719 where M_F denotes the total number of OFDM symbols in the current frame and the value of N
 1720 represents the maximum number of possibly modulated sub-carriers in the OFDM spectrum and
 1721 shall be a power of 2: $N = 2^k$, where k shall be an integer. The value of $Z_{i,l}$ for all masked sub-
 1722 carriers shall be set to 0. If some non-masked sub-carriers with indexes $i < N$ are not modulated (not
 1723 in use), the corresponding values of $Z_{i,l}$ shall be generated as described in §7.1.4.2.6

1724
 1725

1726 **7.1.4.4.2 Cyclic extension and OFDM symbol**

1727 The cyclic extension provides guard interval between data-carrying samples of adjacent OFDM
 1728 symbols. This guard interval is necessary to protect the data-carrying samples from the inter-symbol
 1729 interference (ISI) caused by the previous symbol.

1730 In OFDM guard interval of the l -th OFDM symbol in the frame shall be implemented by pre-
 1731 pending the last $N_{CP}(l)$ samples of the IDFT (called cyclic prefix) to its output N samples, as
 1732 presented in Figure 7-20. The order of samples in the symbol shall be as follows:

- 1733 - The first sample of the symbol is the IDFT output sample $N-N_{CP}(l)$;
 1734 - The last sample of $N_{CP}(l)$ is the IDFT output sample $N-1$; next sample is the IDFT output
 1735 sample 0.

1736 The l -th OFDM symbol consists of N IDFT samples and $N_{CP}(l)$ cyclic extension, samples, in total:

1737
$$N_w(l) = N + N_{CP}(l) \text{ [samples].}$$

1738 After cyclic extension as described above, time domain samples at the reference point $v_{n,1}$ in Figure
 1739 7.19 shall comply with the following equations:

1740
$$v_{n,l} = x_{n-N_{CP}(l),l} = \sum_{i=0}^{N-1} Z_{i,l} \times \exp\left(j \cdot 2\pi \cdot i \frac{n - N_{CP}(l)}{N}\right). \quad \text{for } n = 0 \text{ to } N_w(l) - 1 = N + N_{CP}(l) - 1$$

1741 The number of IDFT samples, N , and the number of windowed samples, β , shall be the same for all
 1742 symbols of the same frame. The value of $N_{CP}(l)$ (and the duration of the symbol $N_w(l)$, accordingly)
 1743 may change during the course of the frame, as following:

- 1744 - All symbols of the header shall have the value of $N_{GL-HD} + \beta$ defined in §7.1.4.6;
 1745 - The first two symbols of the payload shall have the default value $N_{GL-DF} + \beta$, defined in
 1746 §7.1.4.6. If a special channel-estimation symbol is used after the PHY-header, it shall be
 1747 considered as a payload symbol for this purpose;
 1748 - All the rest of the payload symbols shall have the same value of N_{GI} selected from the valid
 1749 values defined in §7.1.4.6 and indicated in the header, as described in §7.1.2.1.

1750

1751 **7.1.4.4.3 Symbol Timing**

1752 The PHY frame consists of a preamble followed by an integer number, M_F , of symbols. The first
 1753 symbol following the preamble (the first symbol of the PHY-header) shall have symbol count 0, and
 1754 the last symbol of the frame shall have symbol count M_F-1 . The time position of each symbol in the
 1755 frame is defined by sample count. The first sample of the symbol with symbol count 0 shall have
 1756 sample count $M(0) = N_{pr} - \beta$, where N_{pr} is the number of samples in the preamble. The count of the
 1757 first sample of the l -th symbol ($l = 1, 2, \dots, M_F-1$) in the frame shall be:

1758
$$M(l) = N_{pr} - \beta + \sum_{k=0}^{l-1} N_S(k),$$

1759 where $N_S(k) = N + N_{CP}(k) - \beta$ and $N_S(k)$ may be different for symbols of the header and payload, as
 1760 described in §7.1.4.6.

1761 **7.1.4.4.4 Windowing, overlap and add**

1762

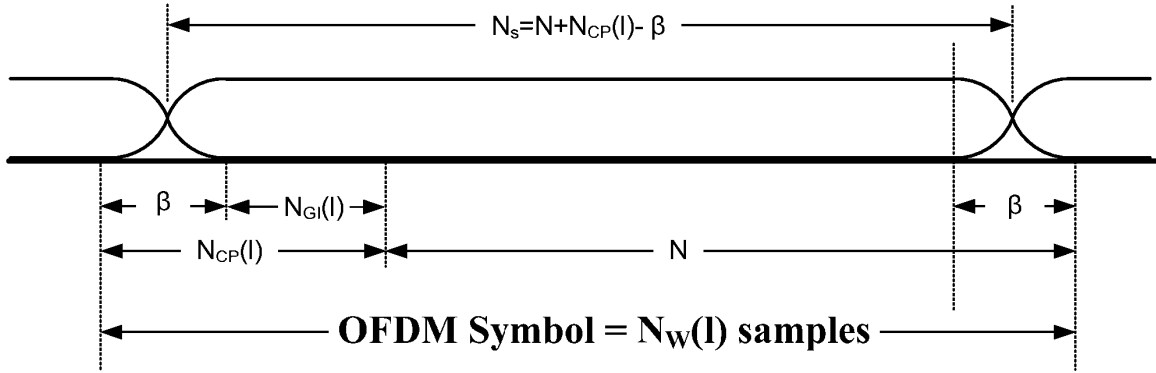

1763
1764

1765 **Figure 7-20/G.9960 – Structure of an OFDM symbol with cyclic extension and overlapped**
1766 **windowing**

1767 The first β samples of the cyclic prefix and last β samples of the IDFT output shall be used for
1768 shaping the envelope of the transmitted signal (windowing). The window function facilitates PSD
1769 shaping: it allows sharp PSD roll-offs used to create deep spectral notches and reduction of the out-
1770 of-band PSD. The number of windowed samples, β , shall be the same for all of the payload symbols of
1771 the same frame, as well as the PHY-header and preamble.

1772 To reduce the modulation overhead, the windowed samples of adjacent symbols shall overlap, as
1773 presented in Figure 7-20. The value of $N_{CP}(l) - \beta = N_{GI}(l)$ forms the guard interval. The duration of the
1774 l -th OFDM symbol is thus $N_S(l) = N + N_{CP}(l) - \beta$.

1775 After windowing, overlap and add, time domain samples at the reference point u_n in Figure 7.19
1776 shall comply with the following equations:

1777
$$u_n = u_n^{(pr)} + \sum_{l=0}^{M_F-1} w(n - M(l), l) \times u_{n-M(l),l} \quad \text{for } n = 0 \text{ to } M(M_F - 1) + N_W(M_F - 1) - 1,$$

1778

1779 where $u_n^{(pr)}$ is the n 'th sample of the preamble, as defined in §7.1.4.5 (Note: the signal $u_n^{(pr)}$ already
1780 includes windowing as necessary), $w(n, l)$ is the windowing function defined on $N_W(l)$ samples of the
1781 OFDM symbol in the following way:

1782
$$w(n, l) = \begin{cases} w_\beta(n) & 0 \leq n < \beta \\ 1 & \beta \leq n < N_W(l) - \beta \\ w_\beta(N_W(l) - 1 - n) & N_W(l) - \beta \leq n < N_W(l) \\ 0 & \text{otherwise} \end{cases}$$

1783 where $w_\beta(n)$ is the function describing the roll-off section of the window. The roll-off function
1784 $w_\beta(n)$ shall be vendor discretionary.

1785 However, $w_\beta(n)$ shall comply with the following rules:

- 1786
 - $w_\beta(n) + w_\beta(\beta - n) = 1$ for $0 \leq n < \beta$.
- 1787
 - $0 \leq w_\beta(n) \leq 1$.

1788 The symbol rate f_{OFDM} (number of symbols per second) and symbol period T_{OFDM} for the given
1789 value of N_{CP} and β shall be computed, respectively:

$$1790 \quad f_{OFDM} = \frac{N \times F_{SC}}{N + N_{CP} - \beta},$$

1791 and $T_{OFDM} = 1/f_{OFDM}$.

1792 **7.1.4.4.5 Frequency up-shift**

1793 The frequency up-shift offsets the spectrum of the transmit signal setting it around the frequency
1794 F_{US} . The value of F_{US} shall be a multiple of the sub-carrier frequency F_{SC} :

$$1795 \quad F_{US} = m \times F_{SC}, \text{ where } m \text{ is an integer and } N/2 \leq m.$$

1796 The valid values of m are specified in §7.1.4.6.

1797 The real and imaginary components of the signal after frequency up-shift (reference point s_n in
1798 Figure 7-19) shall be as follows:

$$1799 \quad s_n = u_{n/p} \times \exp\left(j \frac{2\pi mn}{Np}\right) = \text{Re}(s_n) + j \text{Im}(s_n) \quad \text{for } n = 0 \text{ to } [M(M_F - 1) + N_W(M_F - 1)] \times p - 1;$$

$$\text{Re}(s_n) = \text{Re}(u_{n/p}) \cos\left(\frac{2\pi mn}{Np}\right) - \text{Im}(u_{n/p}) \sin\left(\frac{2\pi mn}{Np}\right)$$

$$\text{Im}(s_n) = \text{Re}(u_{n/p}) \sin\left(\frac{2\pi mn}{Np}\right) + \text{Im}(u_{n/p}) \cos\left(\frac{2\pi mn}{Np}\right)$$

1800

1801 where $u_{n/p}$ is u_n after interpolation with factor p . The interpolation factor p is vendor discretionary,
1802 and shall be equal to or higher than 2.

1803 NOTE: The minimum value of p sufficient to avoid distortions depends on the
1804 ratio between the center frequency F_{US} and the bandwidth of the transmit signal
1805 $BW = N \times F_{SC}$. It is assumed that an appropriate low-pass filter is included to
1806 reduce imaging.

1807 NOTE: The phase of the up-shift should be initialized to zero at the first sample
1808 of the Preamble and be advanced by $\frac{2\pi m}{Np}$ per each sample (after interpolation).

1809 NOTE: For certain values of N_{GI} , β , and m , the phase of the up-shifter at the first
1810 sample of some symbols may not be zero. In these cases a $2N$ -point real-valued
1811 IFFT implementation has to compensate by adjusting phases appropriately in
1812 order to match the modulation described here.

1813 **7.1.4.4.6 Output signal**

1814 For all applications which don't use RF up-converter (further referred to as HF-applications), the
1815 output signal of the modulator shall be the real component of s_n :

$$1816 \quad S_{\text{out-HF}} = \text{Re}(s_n).$$

1817 For RF applications, the RF up-converter shall produce the following output signal:

$$1818 \quad S_{\text{out-RF}}(t) = \text{Re}[s(t) \times \exp(j2\pi F_{UC}t)] = \text{Re}[s(t)] \times \cos(2\pi F_{UC}t) - \text{Im}[s(t)] \times \sin(2\pi F_{UC}t).$$

1819 where F_{UC} is the frequency shift introduced by the RF modulator. The range of F_{UC} and its valid
 1820 values are specified in §7.1.4.6.

1821 After RF up-conversion, the center frequency around which the spectrum of the transmit OFDM
 1822 signal will be placed is $F_{UC} + F_{US}$.

1823 **7.1.4.5 Preamble**

1824 **7.1.4.5.1 General preamble structure**

1825 Preamble is prepended to every PHY frame defined in §7.1.2.1. It is intended to assist the receiver
 1826 detecting, synchronizing to the packet boundaries, and acquiring the physical layer parameters such
 1827 as channel estimation and OFDM symbol alignment. Preamble shall meet the same transmit PSD
 1828 mask (i.e., notches, shapes) as the header and the payload symbols.

1829 Table 7-27 presents the general structure of G.9960 preamble. Each section i comprises N_i
 1830 repetitions of an OFDM symbol (S_i) employing sub-carrier spacing $k_i \times F_{SC}$, where F_{SC} denotes the
 1831 sub-carrier spacing of the payload. A zero value for N_i means that section i is not included in the
 1832 preamble. The values of k_i shall be selected from the set 1, 2, 4 or 8. The preamble sub-carriers of
 1833 section i shall be one in every k_i sub-carriers with respect to the sub-carriers used for the payload
 1834 OFDM symbol starting from sub-carrier zero. Each preamble section shall be windowed as
 1835 necessary in order to comply with the PSD mask. This is illustrated in Figure 7-21.

1836

Table 7-27/G.9960 – General structure of preamble

	1 st Section	2 nd Section	3 rd Section	Header	4 th Section
Number of Symbols (N_i) (Note 1)	N_1	N_2	N_3	Note 5	N_4
Sub-carrier spacing ($k_i \times F_{SC}$)	k_1	$k_2 = k_1$ (Note 2)	k_3		$k_4 = 1$ (Note 3)
OFDM Symbol (S_i)	S_1	$S_2 = -S_1$ (Note 4)	S_3		S_4
Note 1: N_i does not include windowing. Note 2: The sub-carrier spacing of the 2 nd section shall be equal to the sub-carrier spacing of the 1 st section. Note 3: The sub-carrier spacing of the 4 th section shall be the same as sub-carrier spacing of PHY-frame header and payload. Note 4: The OFDM symbol of the 2 nd section shall be an inverted time-domain waveform of the 1 st section. Note 5: Header contains a field (PHI) that indicates $N_4 = 1$ or $N_4 = 0$					

1837

1838 Figure 7-21 shows the G.9960 preamble waveform.

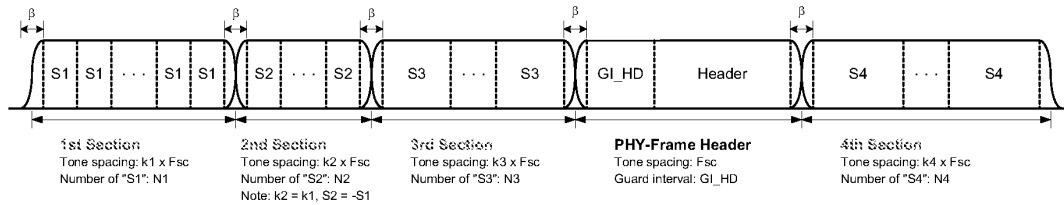

1839

1840

Figure 7-21/G.9960 – Preamble waveform

1841 The number of repetitions of OFDM symbol S_i (N_i) in each of the preamble sections may be a non-integer number to incorporate optional guard interval between sections provided that a fraction of N_i
 1842 integer number to incorporate optional guard interval between sections provided that a fraction of N_i
 1843 conforms the requirement on the guard interval specified in Table 7-28. The specific preamble types
 1844 and construction methods are defined in §7.2.

1845 **7.1.4.5.2 Preamble generation**

1846 This section contains the description of preamble generation method, which is not medium
 1847 dependent. The preamble generation method specific to the type of medium is described under §7.2.

1848 **7.1.4.5.2.1 Frequency-domain symbol generation**

1849 The sub-carriers of the i section of the preamble shall be 1 every k_i sub-carriers with respect to the
 1850 indices of the sub-carriers used for the payload OFDM symbol starting from sub-carrier zero.
 1851 Preamble generator shall output complex values Z_i for each sub-carrier $i = 0, 1, 2, \dots$ to be
 1852 modulated onto symbols of the preamble in accordance with the relevant sub-carrier mask.

1853

1854 **7.1.4.5.2.1.1 Modulation of the preamble symbol**

1855 The non-masked preamble's sub-carriers shall be modulated using a default reference BPSK
 1856 sequence, of all 1's. Other reference sequences are for further study. The reference sequence shall
 1857 be subsequently rotated as specified in §7.1.4.3.3 (Constellation scrambler).

1858 The LFSR generator shall be initialized at the beginning of each one of the used preamble sections
 1859 to a seed that is preamble section and medium dependent as defined in §7.2.

1860 For non-masked preamble's sub-carrier i , Z_i shall be generated by rotating P_i using the two bits that
 1861 are the LSBs of the LFSR, s_1 , and s_2 , as defined in Table 7-26.

1862 The LFSR shall be advanced by 2 bits for each preamble's sub-carrier (either masked or not).

1863 **7.1.4.5.2.2 Time-domain symbol generation**

1864 The Z_i values shall be modulated onto OFDM symbols as described in §7.1.4.4.1.

1865 The output time domain symbol shall be repeated N_i times where N_i denotes the number of replicas
 1866 within section i . If either N_1 or N_3 are non-integer numbers, the fraction of the symbol replica shall
 1867 be at the beginning of the section. If N_2 is a non-integer number, the fraction of the symbols replica
 1868 shall be at the end of the section.

1869 The first, second and third sections of the preamble shall be windowed, overlapped and added as
 1870 described below:

1871 1. First section:

- 1872 a. The first short symbol of the first section is cyclically extended by prepending $\beta/2$
 1873 samples

- 1874 b. The last short symbol of the first section is cyclically extended by appending $\beta/2$
1875 samples
1876 c. The first and last β samples of the extended first section are windowed with a
1877 window function $w_\beta(n)$ and $w_\beta(\beta-n-1)$ respectively.
1878 2. Second section:
1879 a. The first short symbol of the second section is cyclically extended by prepending $\beta/2$
1880 samples
1881 b. The last short symbol of the second section is cyclically extended by appending $\beta/2$
1882 samples
1883 c. The first and last β samples of the extended second section are windowed with a
1884 window function $w_\beta(n)$ and $w_\beta(\beta-n-1)$ respectively.
1885 3. Third section:
1886 a. The beginning of the third section is cyclically extended by prepending β samples.
1887 b. The first and last β samples of the extended third section are windowed with a
1888 window function $w_\beta(n)$ and $w_\beta(\beta-n-1)$ respectively.
1889 4. Overlap and add:
1890 a. The β windowed samples at the end of the first section and at the beginning of the
1891 second section are overlapped and added.
1892 b. The β windowed samples at the end of the second section and at the beginning of the
1893 third section are overlapped and added.
1894 c. The β windowed samples at the end of the third section are overlapped and added
1895 with the β windowed samples at the beginning of the PHY-frame header as
1896 described in §7.1.4.4.4
1897
1898 $w_\beta(n)$ shall comply with the rules specified in §7.1.4.4.4
1899 This is illustrated in Figure 7-22.
1900

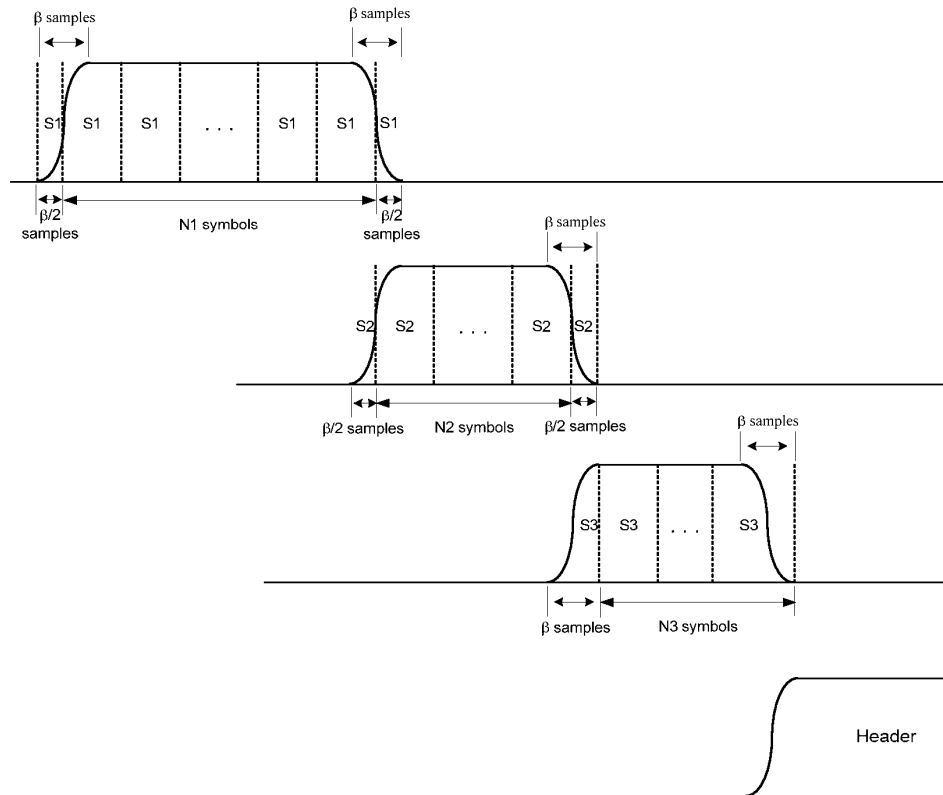

Figure 7-22/G.9960 – Preamble time domain generation

1901
1902

1903

1904 The number of samples in the preamble shall be:

1905
$$N_{pr} = \beta + N_1 \frac{N}{k_1} + N_2 \frac{N}{k_2} + N_3 \frac{N}{k_3}$$

1906 Other approaches for the transition region between the first and second sections of the preamble that
1907 meet the EVM and PSD requirements are allowed.

1908 EVM requirements for the preamble are for further study.

1909 **7.1.4.6 PMD control parameters**

1910 Table 7-28 summarizes valid values of control parameters of an OFDM modulator described in the
1911 sections above. This list is a superset of parameters used over different media; a list of valid values
1912 of modulation parameters and their valid combinations for particular media is presented in §7.2.

1913

Table 7-28/G.9960 – Valid OFDM control parameters

Notation	Parameter	Valid values or range	Note
N	Number of sub-carriers	256, 512, 1024, 2048, 4096	
F_{SC}	Sub-carrier spacing [kHz]	$24.4140625 \times k$, $k = 1, 2, 4, 8, 16, 32, 64$	
N_{GI}	Guard interval [samples]	$k \times N/32$, $k = 1, 2, 3, \dots, 8$	
N_{GI-HD}	Guard interval of the header	$N/4$	
N_{GI-DF}	Default guard interval of the payload	$N/4$	$N_{GI-DF} \geq N_{GI}$
β	Window size [samples]	Any integer between 0 and $N/4$	Range 0- $N/4$
F_{US}	Up-shift frequency, [kHz]	$m \times F_{SC}$, $m \geq N/2$	m is an integer; valid values of m are specified in §7.2
F_{UC}	Center frequency, [kHz]	$F_{UC} = l \times F_G$ where valid values for l are a subset of the range of integers between 13 and 99 $F_G = 25$ MHz	RF applications only Valid values of l are specified in §7.2.3
NOTE – Guard interval and Window size are expressed in samples at Nyquist rate.			

1914

1915

1916 Secondary parameters of the OFDM modulator allow for performance estimation and are presented
1917 in Table 7-29.

1918

Table 7-29/G.9960 – Secondary parameters of the modulator

Notation	Parameter	Note
BW	Total bandwidth [Hz]	$BW = N \times F_{SC}$
N_W	Total number of samples in an OFDM symbol	$N_W = N + N_{CP}$
f_{OFDM}	Symbol rate [symbols/s]	$f_{OFDM} = \frac{N \times F_{SC}}{N + N_{CP} - \beta}$
T_{OFDM}	Symbol period [s]	$T_{OFDM} = 1/f_{OFDM}$
N_{GI}	Guard interval	$N_{GI} = N_{CP} - \beta$

1919

1920 **7.1.4.7 Symbol boost**

1921 Symbols of preamble and header can be sent with higher power (boosted) relative to the symbols of
1922 the payload. The boosting shall be achieved by increasing the power of each active sub-carrier in
1923 the boosted symbol by the same value in dB. Details of symbol boost are for further study.

1924

1925 **7.1.5 Transmit PSD Mask**

1926 Transmit PSD mask is a superposition of a Sub-carrier Mask (SM), a PSD Shaping Mask (PSM),
1927 and a PSD ceiling (PSDC) defined in this section, and the Limit PSD Mask (LPM) defined for each
1928 particular medium. The PSD of the transmit signal at any frequency shall never exceed the Transmit
1929 PSD Mask.

1930 The LPM (see §7.2.1.3, §7.2.2.3 and §7.2.3.3) specifies the absolute limit of the transmit PSD,
1931 intended for deployments with no special conditions. The SM, PSDC, and PSM provide further
1932 reduction and shaping of the transmit PSD using three mechanisms: sub-carrier masking (notching),
1933 PSD ceiling (limit on PSD level), and PSD shaping.

1934 G.9960 transceivers shall support sub-carrier masking, notching of International Amateur radio
1935 bands, and PSD ceiling. Support of PSD shaping is optional.

1936 **7.1.5.1 Sub-carrier masking (notching)**

1937 This type of shaping shall be used to eliminate transmission on one or more sub-carriers. Sub-
1938 carrier masking is defined by a Sub-carrier Mask (SM). Transmit power of sub-carriers specified in
1939 SM shall be set to zero. SM shall override all other instructions related to the transmit power of the
1940 sub-carrier.

1941 SM is defined as a number of masked frequency bands. Each band is specified by a start sub-carrier
1942 index (x_L) and a stop sub-carrier index (x_H), as $\{x_L, x_H\}$. An SM including S bands can be
1943 represented in the following format:

1944
$$SM(S) = [\{x_{L1}, x_{H1}\}, \{x_{L2}, x_{H2}\}, \dots \{x_{LS}, x_{HS}\}].$$

1945 All sub-carriers within the band, i.e., with indices equal or higher than x_L and lower than or equal to
1946 x_H , shall be switched off (transmitted with zero power).

1947 International Amateur radio bands (see Annex D) are not a part of SM. In case Amateur radio bands
1948 are used for transmission, the node shall be capable to turn off one or more of Amateur radio bands
1949 using SM, by configuring one or more of SM bands coinciding with the Amateur radio bands.

1950

1951 **7.1.5.2 PSD ceiling**

1952 PSD ceiling (PSDC) specifies the PSD level that is used to impose a limit (i.e., a ceiling function)
1953 on the transmit PSD mask. PSDC is independent of frequency and indicated by a single value in
1954 dBm/Hz. The valid range of PSDC values is from -50 dBm/Hz to -100 dBm/Hz with steps of 2 dB.

1955 PSDC shall be supported by all G.9960 transceivers.

1956

1957 **7.1.5.3 PSD shaping**

1958 PSD shaping allows transmit PSD reduction of PSD in some parts of the spectrum, mainly for
1959 spectrum compatibility and coexistence with other HN technologies. PSD shaping is specified by a
1960 PSM.

1961 PSM is defined on the frequency range between the lowest sub-carrier x_1 and the highest sub-carrier
1962 x_H allowed for transmission, and consists of one or more frequency segments. The boundaries of the
1963 segments are defined by set breakpoints. Inside of each segment, PSD may be either constant or
1964 may form a linear slope, Figure 7-23.

1965

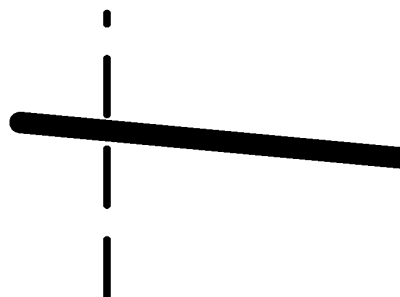

DCN Shanghai Mr

1966

1967

Figure 7-23/G.9960 – Construction of PSM

1968 Each breakpoint of PSM is specified by a sub-carrier index x_n and a value of PSD_n at that sub-
 1969 carrier expressed in dBm/Hz, $\{x_n, PSD_n\}$. The first breakpoint is always set to the lowest sub-carrier
 1970 allowed for transmission (index x_1) and the last breakpoint is set to the highest sub-carrier allowed
 1971 for transmission (index x_H). A PSM including S segments can be represented by $(S+1)$ breakpoints
 1972 in the following format:

1973
$$PSM(S) = [\{x_1, PSD_1\}, \{x_2, PSD_2\} \dots \{x_S, PSD_S\}, \{x_H, PSD_H\}].$$

1974 A node supporting PSD shaping, shall support up to 8 PSM breakpoints. If a node does not support
 1975 PSD shaping, all sub-carriers subject to the PSD shaping requirement specified by PSM shall be
 1976 masked (switched off).

1977 The maximum steepness of PSM slopes is for further study.

1978 If one or more PSM breakpoints are set above the LPM or PSDC, the transmit PSD mask shall be
 1979 set to: $TxPSD = \min(PSM, LPM, PSDC)$. At least one of PSM breakpoints shall be on the LPM
 1980 (this breakpoint corresponds to $tss = 1$). All values of PSD_n of PSM breakpoints shall be set above
 1981 PSM_{min} . The value of PSM_{min} shall not be more than 30 dB below the peak of the PSD mask.

1982 NOTE: PSM breakpoints do not have any relation with SM breakpoints; SM and notched
 1983 International Amateur radio bands always overrides PSM if defined over the same indices.

1984 **7.1.5.4 Notching of International Amateur radio bands**

1985 Any node operating over phone line or power line shall be able to reduce the PSD of the transmitted
 1986 signal to a level below -80 dBm/Hz in all International Amateur radio bands (see Annex D)
 1987 simultaneously or in any selected group of them. The band to be notched is specified by the start
 1988 and stop sub-carrier indices, same as described in §7.1.5.1. The PSD slopes forming a notch are
 1989 vendor discretionary.

1990

1991 **7.2 Media dependent specification**

1992 **7.2.1 Physical layer specification over phone lines**

1993 **7.2.1.1 Control parameters**

1994 Table 7-30 shows the OFDM control parameters for various bandplans defined in phone lines.

1995

Table 7-30/G.9960 – OFDM control parameters for phone lines

Domain Type	Phone Line Baseband	
	50MHz – TB (NOTE 2)	100MHz – TB (NOTE 3)
N	1024	2048
F_{SC}	48.828125 kHz	48.828125kHz
N_{GI}	$N/32 \times k$ for $k=1, \dots, 8$ samples @ 50 Msamples/s	$N/32 \times k$ for $k=1, \dots, 8$ samples @ 100 Msamples/s
N_{GI-HD}	$N/4 = 256$ samples @ 50 Msamples/s	$N/4 = 512$ samples @ 100 Msamples/s
N_{GI-DF}	$N/4=256$ samples @ 50 Msamples/s	$N/4=512$ samples @ 100 Msamples/s
β	$N/32 = 32$ samples @ 50 Msamples/s	$N/32 = 64$ samples @ 100 Msamples/s
F_{US}	25 MHz	50 MHz
$F_C = F_{UC} + F_{US}$	$F_{UC} = 0$	$F_{UC} = 0$
Sub-carrier frequency f for sub-carrier index i (NOTE 1)	$f = i \times F_{SC}$ where $i = 0$ to $i = N - 1$ (indexing rule #1)	$f = i \times F_{SC}$ where $i = 0$ to $i = N - 1$ (indexing rule #1)
NOTES: 1. See §7.1.4.1 for more details on sub-carrier indexing rules. 2. The range of sub-carrier frequencies is between 0 and 50 MHz 3. The range of sub-carrier frequencies is between 0 and 100 MHz		

1996

1997 **7.2.1.2 Preamble**

1998 **7.2.1.2.1 Default preamble structure**

1999 Table 7-31 illustrates the default preamble structure for phone line.

2000

Table 7-31/G.9960 – Default preamble structure for phone line

	1 st Section	2 nd Section	3 rd Section	Header	4 th Section
Number of Symbols (N_i)	8	2	0	NOTE	1.25
Sub-carrier spacing ($k_i \times F_{SC}$)	8	8	0		1
NOTE – The value for PHI in the PHY-frame header shall be set to 1 (N_4).					

2001

2002 **7.2.1.3 PSD mask specifications**

2003 The Limit PSD mask for operation over phone lines (bandplans 50MHz-TB and 100MHz-TB) shall
 2004 be as presented in Figure 7-24 with the values of frequencies f_L - f_H as presented in Table 7-32.

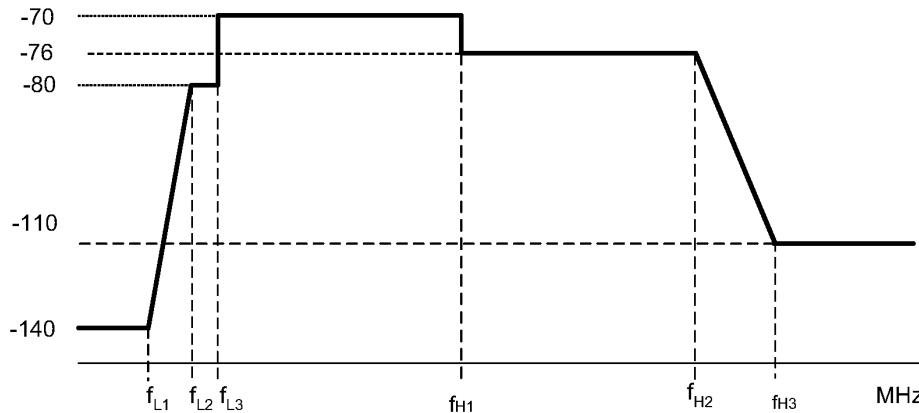

2005

**Figure 7-24/G.9960 – Limit PSD mask for transmission over phone lines
 (Amateur radio-band notches are not shown)**

2006

2007

2008

2009 NOTE: Figure 7-24 doesn't include Amateur radio notches.

2010

2011 The values of frequency spectrum parameters for phone lines are presented in Table 7-32. Interim
 2012 points between those define in Figure 7-24 shall be obtained by linear interpolation (in dB over
 2013 linear frequency scale).

2014

Table 7-32/G.9960 – Parameters of Limit PSD mask over phone lines

Parameters	Frequency, MHz	PSD, dBm/Hz	Note/Description
f_{L1}	1.7	-140	Provides protection of splitter-less ADSL
f_{L2}	3.5	-80	Coincides with the Amateur radio band
f_{L3}	4.0		
$f_{L3} + \Delta F$	$4.0 + \Delta F$	-70	ΔF is an arbitrary small positive value
f_{HAM}	As defined in Table D-1	-80	Additional notches can be added based on regional regulations
$f_{H1} - \Delta F$	$30 - \Delta F$	-70	ΔF is an arbitrary small positive value
f_{H1}	30	-76	
f_{H2}	100		
f_{H3}	120	-110	
NOTE – All sub-carriers below $f_{L3} + \Delta F$, and above $f_{H2} - \Delta F$, and inside the notched Amateur radio bands shall not be used for transmission (neither data nor any auxiliary information).			

2015
2016

2017

NOTES:

2018

2019

2020

2021

2022

2023

2024

1. The Limit PSD mask shown in Figure 7-24 presents for the case when all sub-carriers allowed for transmission are in use, each with its maximum transmit power. In case of additional spectrum shaping is used as described in §7.1.5.3 (e.g. to provide spectrum compatibility, comply with wide-band power limit, or other), various parts of this PSD mask could be reduced by switching sub-carriers off or reducing their transmit power. Additional frequency notches may be applied if required.

2025

2026

2027

2028

2. VDSL is usually deployed using a service splitter (G.993.2 doesn't encourage splitterless VDSL installations). This allows the use of the G.9960 spectrum down to f_{L3} . If splitterless VDSL is used, the low frequency of G.9960 spectrum shall be moved up and set above the upper downstream sub-carrier of VDSL2.

2029

2030

2031

7.2.2 Physical layer specification over power lines

2032

7.2.2.1 Control parameters

2033

Table 7-33 shows the OFDM control parameters for various bandplans defined in power lines.

2034

Table 7-33/G.9960 – OFDM control parameters for power lines

Domain Type	Power Line Baseband		Power Line Passband
	50MHz – PB (NOTE 3)	100MHz – PB (NOTE 4)	100MHz – PP (NOTE 5)
N	2048	4096	1024
F_{SC}	24.4140625 kHz	24.4140625 kHz	97.65625 kHz
N_{GI}	$N/32 \times k$ for $k=1, \dots, 8$ samples @ 50 Msamples/s	$N/32 \times k$ for $k=1, \dots, 8$ samples @ 100Msamples/s	$N/32 \times k$ for $k=1, \dots, 8$ samples @ 100Msamples/s
N_{GI-HD}	$N/4=512$ samples @ 50 Msamples/s	$N/4=1024$ samples @ 100 Msamples/s	$N/4=256$ samples @ 100 Msamples/s
N_{GI-DF}	$N/4=512$ samples @ 50 Msamples/s	$N/4=1024$ samples @ 100 Msamples/s	$N/4=256$ samples @ 100 Msamples/s
β	$N/8 = 256$ samples @ 50 Msamples/s	$N/8 = 512$ samples @ 100 Msamples/s	$N/32 = 32$ samples @ 100 Msamples/s
F_{US}	25 MHz	50 MHz	150 MHz
$F_C = F_{UC} + F_{US}$	$F_{UC} = 0$	$F_{UC} = 0$	$F_{UC} = 0$
Sub-carrier frequency f for sub-carrier index i (NOTE 1)	$f = i \times F_{SC}$ where $i = 0$ to $i = N - 1$ (indexing rule #1)	$f = i \times F_{SC}$ where $i = 0$ to $i = N - 1$ (indexing rule #1)	$f = F_{US} - (N/2 - i) \times F_{SC}$ where $i = 0$ to $i = N - 1$ (indexing rule #1)
<p>NOTES:</p> <ol style="list-style-type: none"> 1. See §7.1.4.1 for more details on sub-carrier indexing rules. 2. The 50 MHz and 100 MHz bandplans may be used by nodes operating in the same Power Line Baseband domain. 3. The range of sub-carrier frequencies is between 0 and 50 MHz 4. The range of sub-carrier frequencies is between 0 and 100 MHz 5. The range of sub-carrier frequencies is between 100 MHz and 200 MHz 			

2035

2036 **7.2.2.2 Preamble**

2037 **7.2.2.2.1 Default preamble structure**

2038 Table 7-34 illustrates the default preamble structure for power line.

2039

Table 7-34/G.9960 – Default preamble structure for power line

	1 st Section	2 nd Section	3 rd Section	Header	4 th Section
Number of Symbols (N_i)	7	2	0	NOTE	1.25
Sub-carrier spacing ($k_i \times F_{SC}$)	8	8	0		1
NOTE – The value for PHI in the PHY-frame header shall be set to 1 (N_4).					

2040

2041 **7.2.2.3 PSD mask specifications**

2042

2043 The baseband Limit PSD mask for operation over power lines (bandplans 50MHz-PB and 100MHz-
 2044 PB) shall be as presented in Figure 7-25 with the values of frequencies f_L - f_H as presented in Table
 2045 7-35. The passband Limit PSD mask for operation over power lines (bandplan 100MHz-PP) shall
 2046 be as defined in Figure 7-26 and Table 7-36.

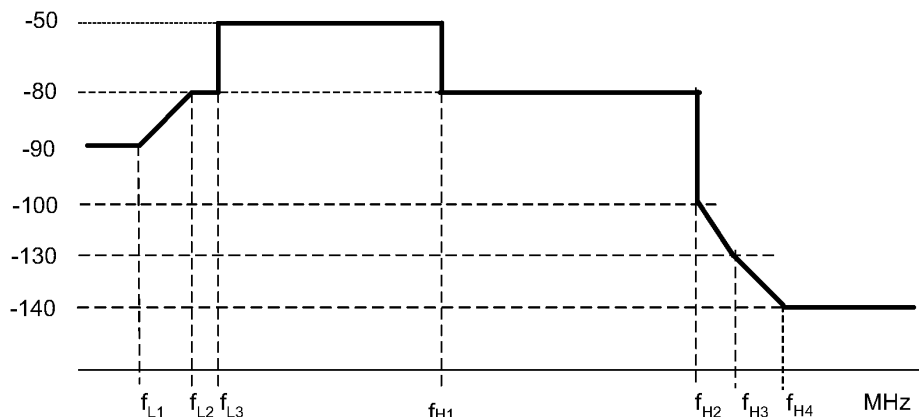

2047

Figure 7-25/G.9960 – Limit PSD mask for baseband transmission over power lines (Amateur radio-band notches are not shown)

2048
2049

2050

NOTE: Figure 7-25 doesn't include Amateur radio notches.

2052

2053 The frequency spectrum parameters for baseband bandplans are presented in Table 7-35. Interim
 2054 points between those defined in Figure 7-25 are obtained by linear interpolation (in dB over linear
 2055 frequency scale).

2056
2057

Table 7-35/G.9960 – Parameters of Limit PSD mask for bandplans 50MHz-PB and 100MHz-PB

Parameters	Frequency, MHz	PSD, dBm/Hz	Note/Description
f_{L1}	1.1	-90	Additional reduction below 1.1 MHz is to reduce crosstalk into ADSL
f_{L2}	1.8	-80	Coincides with the Amateur radio band
f_{L3}	2.0		
$f_{L3} + \Delta F$	$2.0 + \Delta F$	-50	ΔF is an arbitrary small positive value
f_{HAM}	As defined in Table D-1	-80	Additional notches could be added based on regional regulations
$f_{H1} - \Delta F$	$30 - \Delta F$	-50	ΔF is an arbitrary small positive value
f_{H1}	30	-80	ΔF is an arbitrary small positive value
f_{H2}	$100 - \Delta F$		
f_{H2}	100	-100	
f_{H3}	110	-130	
f_{H4}	120	-140	

NOTE – All sub-carriers below $f_{L3} + \Delta F$, and above $f_{H2} - \Delta F$, and inside the notched Amateur radio bands shall not be used for transmission (neither data nor any auxiliary information).

2058

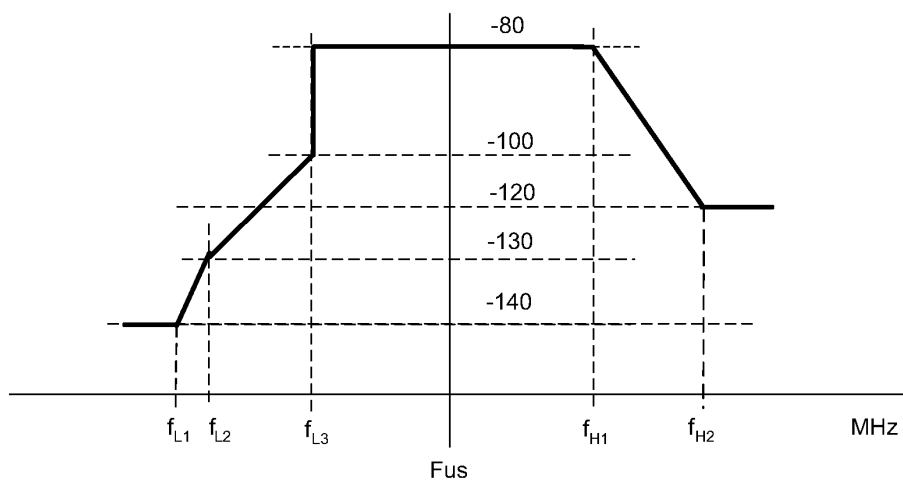

2059

2060

Figure 7-26/G.9960 – Limit PSD mask for passband transmission over power lines

2061

The frequency spectrum parameters for passband bandplans are presented in Table 7-36. Interim points between those defined in Figure 7-26 are obtained by linear interpolation (in dB over linear frequency scale).

2062

2063

2064 **Table 7-36/G.9960 – Parameters of Limit PSD mask for bandplan 100MHz-PP**

Parameters	Frequency, MHz	PSD, dBm/Hz	Note/Description
f_{L1}	80	-140	
f_{L2}	90	-130	
f_{L3}	100	-100	
$f_{L3} + \Delta F$	$100 + \Delta F$	-80	ΔF is an arbitrary small positive value
f_{H1}	200	-80	
f_{H2}	240	-120	
All sub-carriers below $f_{L3} + \Delta F$, and above $f_{H1} - \Delta F$, and inside the notched Amateur radio bands will not be used for transmission (neither data nor any auxiliary information).			

2065 NOTES:

2066 1. The Limit PSD mask shown in Figure 7-25 and Figure 7-26 presents the case
 2067 when all sub-carriers allowed for transmission are in use, each with its maximum
 2068 transmit power. In case of additional spectrum shaping is used as described in
 2069 §7.1.5.3 (e.g. to provide spectrum compatibility with VDSL, comply with wide-
 2070 band power limit, or other), various parts of this PSD mask could be reduced by
 2071 switching sub-carriers off or reducing their transmit power. Additional frequency
 2072 notches may be applied if required.

2073 2. The value of -80dBm/Hz for the required attenuation in Amateur radio bands
 2074 is adopted from [1]. This value might be revised for G.9960 due to concerns of
 2075 reduced balance of power line wires.

2076

2077 **7.2.3 Physical layer specification over coax**

2078 **7.2.3.1 Control parameters**

2079 Table 7-37 shows the OFDM control parameters for various bandplans defined in coax cable.

2080

Table 7-37/G.9960 – OFDM control parameters for coax cables

Domain Type	Coax Baseband		Coax RF	
	50MHz – CB (NOTE 4)	100MHz – CB (NOTE 5)	50MHz – RF (NOTE 6)	100MHz – RF (NOTE 7)
N	256	512	256	512
F_{SC}	195.3125 kHz	195.3125 kHz	195.3125 kHz	195.3125 kHz
N_{GI}	$N/32 \times k$ for $k=1, \dots, 8$ samples @ 50 Msamples/s	$N/32 \times k$ for $k=1, \dots, 8$ samples @ 100 Msamples/s	$N/32 \times k$ for $k=1, \dots, 8$ samples @ 50 Msamples/s	$N/32 \times k$ for $k=1, \dots, 8$ samples @ 100 Msamples/s
N_{GI-HD}	$N/4=64$ samples @ 50 Msamples/s	$N/4=128$ samples @ 100 Msamples/s	$N/4=64$ samples @ 50 Msamples/s	$N/4=128$ samples @ 100 Msamples/s
N_{GI-DF}	$N/4=64$ samples @ 50 Msamples/s	$N/4=128$ samples @ 100 Msamples/s	$N/4=64$ samples @ 50 Msamples/s	$N/4=128$ samples @ 100 Msamples/s
β	$N/32=8$ samples @ 50 Msamples/s	$N/32=16$ samples @ 100 Msamples/s	$N/32=8$ samples @ 50 Msamples/s	$N/32=16$ samples @ 100 Msamples/s
F_{US}	25 MHz	50 MHz	25 MHz	50 MHz
$F_C = F_{UC} + F_{US}$	$F_{UC} = 0$	$F_{UC} = 0$	$F_C = X$ (NOTE 3)	$F_C = Y$ (NOTE 3)
Sub-carrier frequency f for sub-carrier index i (NOTE 1)	$f = i \times F_{SC}$ where $i = 0$ to $i = N - 1$ (indexing rule #1)	$f = i \times F_{SC}$ where $i = 0$ to $i = N - 1$ (indexing rule #1)	indexing rule #1 if $X \neq Y$, or indexing rule #2 if $X = Y$. (NOTE 8)	indexing rule #1 if $X \neq Y$, or indexing rule #2 if $X = Y$. (NOTE 8)
<p>NOTES:</p> <ol style="list-style-type: none"> See §7.1.4.1 for more details on sub-carrier indexing rules. The 50MHz and 100MHz bandplans may be used by nodes operating in the same Coax Baseband domain. The same principle applies to 50MHz and 100MHz bandplans defined for Coax RF domain. The values of center frequency F_C shall be selected from the valid set defined in Table 7-28 and may be subject to regional spectrum management rules (see regional Annexes). The range of sub-carrier frequencies is between 0 and 50 MHz The range of sub-carrier frequencies is between 0 and 100MHz The range of sub-carrier frequencies is between $(X - 25)$ MHz and $(X + 25)$ MHz The range of sub-carrier frequencies is between $(Y - 50)$ MHz and $(Y + 50)$ MHz The specific indexing rule is specified in each regional Annex. 				

2081

2082 **7.2.3.2 Preamble**

2083 **7.2.3.2.1 Default preamble structure**

2084 Table 7-38 illustrates the default preamble structure for Coax BB.

2085

Table 7-38/G.9960 – Default preamble structure for coax BB

	1 st Section	2 nd Section	3 rd Section	Header	4 th Section
Number of Symbols (N_i)	10	4	2.5	NOTE	0
Sub-carrier spacing ($k_i \times F_{SC}$)	4	4	1		N/A
NOTE – The value for PHI in the PHY-frame header shall be set to 0 (N_4).					

2086

2087 Table 7-39 illustrates the default preamble structure for Coax RF.

2088

Table 7-39/G.9960 – Default preamble structure for coax RF

	1 st Section	2 nd Section	3 rd Section	Header	4 th Section
Number of Symbols (N_i)	10	4	2.5	NOTE	0
Sub-carrier spacing ($k_i \times F_{SC}$)	4	4	1		N/A
NOTE – The value for PHI in the PHY-frame header shall be set to 0 (N_4).					

2089

2090 **7.2.3.3 PSD mask specifications**

2091 The Limit PSD mask for operation over RF coax (bandplans 50MHz-RF, 100MHz-RF) is presented
 2092 in Figure 7-27 with the frequencies as presented in Table 7-40 and with the bandwidth $BW = f_{H1} -$
 2093 f_{L3} .

2094

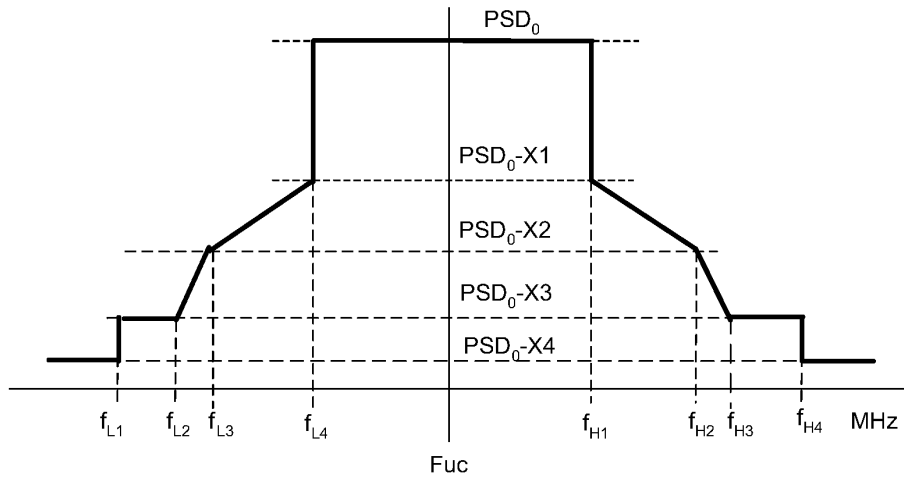

2095

2096 **Figure 7-27/G.9960 - Limit PSD mask of a single channel for RF transmission over coax**

2097 The proposed values of frequency spectrum parameters for coax are presented in Table 7-40 and
2098 Table 7-41. It is assumed that interim points between those defined in Figure 7-27 are obtained by
2099 linear interpolation (dB over linear frequency scale).

2100 Table 7-40/G.9960 – Parameters of Limit PSD mask over RF coax for bandplan 50MHz-RF

Parameters	Frequency, MHz	PSD, dBm/Hz (NOTE)	Note/Description
$F_{UC} - f_{L1}$	75	PSD ₀ - 50	
$F_{UC} - f_{L2}$	50	PSD ₀ - 45	
$F_{UC} - f_{L3}$	35	PSD ₀ - 40	
$F_{UC} - f_{L4}$	25	PSD ₀ - 20	
	$f_{L4} + \Delta F$	PSD ₀	ΔF is an arbitrary small positive value
F_{UC}	$M*25\text{MHz}$	PSD ₀	
	$f_{H1} - \Delta F$	PSD ₀	ΔF is an arbitrary small positive value
$f_{H1} - F_{UC}$	25	PSD ₀ - 20	
$f_{H2} - F_{UC}$	35	PSD ₀ - 40	
$f_{H3} - F_{UC}$	50	PSD ₀ - 45	
$f_{H4} - F_{UC}$	75	PSD ₀ - 50	
NOTE – PSD ₀ = -68 dBm/Hz			

2101 Table 7-41/G.9960 – Parameters of Limit PSD mask over RF coax for bandplan 100MHz-RF

Parameters	Frequency, MHz	PSD, dBm/Hz (NOTE)	Note/Description
$F_{UC} - f_{L1}$	150	PSD ₀ - 50	
$F_{UC} - f_{L2}$	100	PSD ₀ - 45	
$F_{UC} - f_{L3}$	70	PSD ₀ - 40	
$F_{UC} - f_{L4}$	50	PSD ₀ - 20	
	$f_{L4} + \Delta F$	PSD ₀	ΔF is an arbitrary small positive value
F_{UC}	$M*25\text{MHz}$	PSD ₀	
	$f_{H1} - \Delta F$	PSD ₀	ΔF is an arbitrary small positive value
$f_{H1} - F_{UC}$	50	PSD ₀ - 20	
$f_{H2} - F_{UC}$	70	PSD ₀ - 40	
$f_{H3} - F_{UC}$	100	PSD ₀ - 45	
$f_{H4} - F_{UC}$	150	PSD ₀ - 50	
NOTE – PSD ₀ = -68 dBm/Hz			

2102

2103

NOTES:

2104

1. All sub-carriers below $f_{L4} + \Delta F$, above $f_{H1} - \Delta F$ will not be used for transmission (neither data nor any auxiliary information).

2105

2106

2. The Limit PSD mask shown in Figure 7-27 presents the case when all sub-carriers allowed for transmission are in use, each with its maximum transmit power. In case additional spectrum shaping is used, as described in §7.1.5.3, the transmit PSD mask can be reduced in the relevant parts of this spectrum by switching sub-carriers off or reducing their transmit power.

2107

2108

2109

2110

2111

3. In cases when more than one channel is established over the same coax cable, appropriate gaps between center frequencies of the channels should be set to account values of the out-of-band PSD presented in Table 7-40 and Table 7-41.

2112

2113

2114

2115 4. Out-of-band spurious signals at the output of G.9960 node operating over coax
 2116 in RF mode are supposed to meet the Limit PSD mask defined in Table 7-40 and
 2117 Table 7-41. The limit for total power of out-of-band spurious signals is for further
 2118 study. The requirements for in-band spurious signals are for further study.

2119 5. Specification of guard bands are for further study.

2120

2121 The Limit PSD mask for operation over baseband coax (bandplans 50MHz-CB, 100MHz-CB) is
 2122 presented in Figure 7-28 with the frequencies and PSD levels presented in Table 7-42, Table 7-43
 2123 and with the bandwidth $BW = f_{H1} - f_{L2}$.

2124

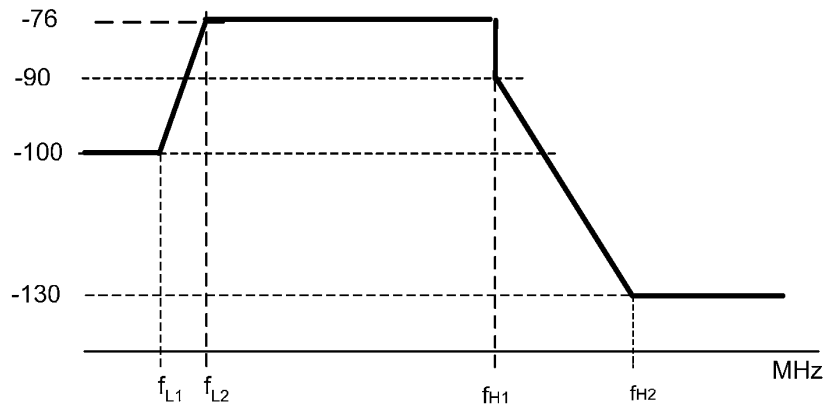

2125

Figure 7-28/G.9960 - Limit PSD mask of baseband coax

2126

2127

2128 The interim points between those defined in Figure 7-28 are obtained by linear interpolation (dB
 2129 over linear frequency scale).

2130 Table 7-42/G.9960 – Parameters of Limit PSD mask over coax for bandplan 50 MHz-CB

Parameters	Frequency, MHz	PSD, dBm/Hz	Note/Description
f_{L1}	1	-100	
f_{L2}	5	-76	
$f_{H1} - \Delta F$	$50 - \Delta F$	-76	ΔF is an arbitrary small positive value
f_{H1}	50	-76	
f_{H2}	70	-135	

2131

2132 **Table 7-43/G.9960 – Parameters of Limit PSD mask over coax for bandplan 100MHz-CB**

Parameters	Frequency, MHz	PSD, dBm/Hz	Note/Description
f_{L1}	1	-100	
f_{L2}	5	-76	
$f_{H1} - \Delta F$	$100 - \Delta F$	-76	ΔF is an arbitrary small positive value
f_{H1}	100	-76	
f_{H2}	140	-135	

2133

2134 NOTES:

2135 1. All sub-carriers below f_{L2} and above $f_{H1} - \Delta F$ will not be used for transmission
 2136 (neither of data nor of any auxiliary information).

2137 2. The Limit PSD mask shown in Figure 7-28 presents the case when all sub-
 2138 carriers allowed for transmission are in use, each with its maximum transmit
 2139 power. In case additional spectrum shaping is used, as described in §7.1.5.3, the
 2140 transmit PSD mask can be reduced in the relevant parts of this spectrum by
 2141 switching sub-carriers off or reducing their transmit power.

2142 **7.2.3.4 Coexistence on coax**

2143 G.9960 nodes on coax shall use specified detection and frequency agility capabilities and
 2144 procedures to avoid interfering with non-G.9960 networks and other services (e.g., communication
 2145 and broadcast services) operating on the same coax plant. Details of these capabilities and
 2146 procedures will be specified in a future version of this Recommendation.

2147 **7.2.4 Transmitter EVM Requirements**

2148 EVM requirements are for further study.

2149

2150

2151

2152

Annex A – Regional requirements for North America

2153

2154

For further study

2155

2156

2157 **Annex C – Regional requirements for Japan**

2158

2159 **C.1 Scope**

2160 This annex describes domestic practices, standards for each medium (coax cable, phone line and
2161 power line) and the way to apply the G.9960 system under those conditions in Japan.

2162 **C.2 Media dependent specification**

2163 **C.2.1 Physical layer specification over phonelines**

2164 For further study.

2165 **C.2.2 Physical layer specification over powerlines**

2166 **C.2.2.1 Frequency use for powerlines**

2167 All HN nodes over powerlines shall comply with national regulations in Japan [1], which states the
2168 frequency band that one can use without any license is restricted to between 2 MHz and 30 MHz,
2169 and the interference level due to power line communication is also restricted.

2170 Furthermore, the regulations give limitations of where they can be used; that is, the usage of power
2171 line communications is only limited inside buildings and not allowed outside buildings.

2172 **C.2.3 Physical layer specification over coax**

2173 **C.2.3.1 Bandplan**

2174 In addition to the OFDM control parameters in Table 7-37, the OFDM control parameters shown in
2175 Table C-1 may be used. It should be noted that coaxial home network connected to cable access
2176 network should not interfere the services offered by the cable television operator to customers.

2177

Table C-1/G.9960 – Optional OFDM control parameters for coax cables in Japan

Domain Type	Coax RF
Bandplan Name	200MHz – RF (NOTES 2, 3)
N	1024
F _{SC}	195.3125 kHz
N _{GI}	For further study
N _{GI-HD}	For further study
N _{GI-DF}	For further study
β	For further study
F _{US}	100 MHz
F _C = F _{UC} + F _{US}	F _C = Z (NOTE 4)
Sub-carrier frequency f for sub-carrier index i (NOTE 1)	Indexing rule #2 if X=Y=Z, otherwise #1. (NOTE 5)
<p>NOTES:</p> <ol style="list-style-type: none"> 1. See §7.1.4.1 for more details on sub-carrier indexing rules. 2. The 200MHz bandplan on this table and the 50MHz and 100MHz bandplans shown in Table 7-37 may be used by nodes operating in the same Coax RF domain. 3. The range of sub-carrier frequencies is between (Z – 100) MHz and (Z + 100) MHz 4. The values of center frequency F_C shall be selected from the valid set defined in Table 7-28 and may be subject to regional spectrum management rules. 5. X and Y are F_C of bandplan 50MHz-RF and 100MHz-RF respectively (See Table 7-37). 	

2178

2179 **C.2.3.2 Transmitter EVM Requirements for RF coax**

2180 The EVM requirements are for further study.

2181 **C.3 Bibliography**

2182 [1] Radio wave Law enforcement regulations 46-2 (Japanese), <http://law.e->

2183 gov.go.jp/htmldata/S25/S25F30901000014.html

2184

2185

Annex D – International Amateur radio bands

2186

2187

Table D-1/G.9960 – International Amateur radio bands in the frequency range 0-30 MHz

Band start (kHz)	Band stop (kHz)
1 800	2 000
3 500	4 000
7 000	7 300
10 100	10 150
14 000	14 350
18 068	18 168
21 000	21 450
24 890	24 990
28 000	29 700

2188 **Appendix I: Consideration of Domains Comprising Multiple Wire Classes**

2189

2190 The focus of the HN network is to optimize domains to operate on each individual wire class with
2191 multiple domains interconnected via inter-domain bridges. However, it is possible to interconnect
2192 wire classes at the physical layer. Figure I-1 shows several possibilities for such an arrangement.
2193 Figure I-1 (A) shows an example network segment comprising coax, phone line and power line.
2194 These wires are interconnected at the physical layer; the coax and phone line by a balun, and the
2195 phone line and power line by a high-pass filter. Figure I-1 (B) shows a similar case except that the
2196 power line segment is no longer connected at the physical layer, instead connecting to the phone
2197 line segment via an inter-domain bridge. The physical layer interconnections shown in Figure I-1
2198 are expected to be a small subset of the wiring scenarios encountered when installing an HN
2199 network, and it is assumed that such practices will be avoided if possible.

2200

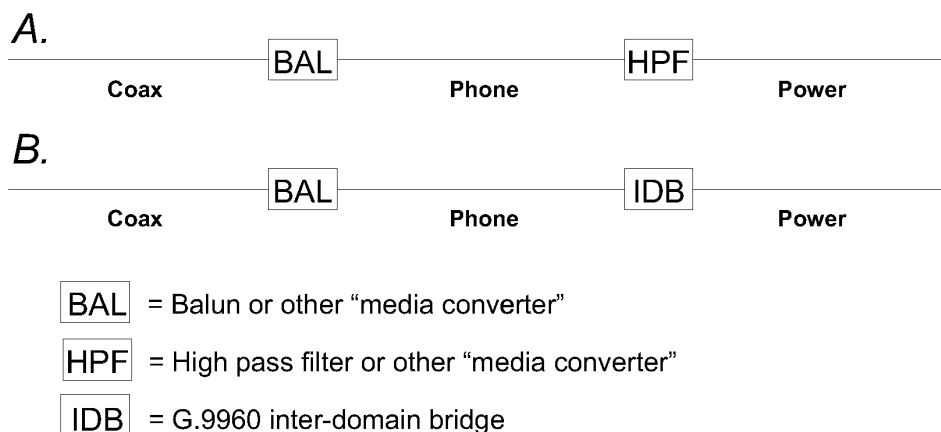

2201

2202 **Figure I-1/G.9960 – Example network segments with multiple wire classes connected at the**
2203 **physical layer**

2204 By definition a medium is a wire-line facility, of a single wire class, allowing physical connection
2205 between network nodes. For the types of cases shown in Figure I-1, having multiple wire classes
2206 interconnected by physical layer connections, a medium may be considered to comprise the
2207 multiple wire classes and the devices interconnecting them. Given this consideration, a domain
2208 may operate over this extended medium. This special use of the term, *medium*, is demonstrated in
2209 Figure I-2.

2210 Figure I-2 shows the same network segments given in Figure I-1, and a relative comparison to the
2211 relationships between domain, medium and wire class that is shown in Figure 5-5. The allowance
2212 for a medium to comprise multiple wire classes in this special case also permits a domain to extend
2213 across multiple wire classes that are connected at the physical layer. Figure I-2 (A) shows a domain
2214 covering the physically connected coax, phone line and power line segments from Figure I-1 (A),
2215 and Figure I-2 (B) similarly shows the physically connected coax and phone line segments of
2216 Figure I-1 (B) as well as showing the separate power line domain. Figure I-2 (C) highlights the

2217 capability to have multiple domains, showing two domains (with implied inter-domain bridging)
2218 over the coax/phone line combination from Figure I-2 (B).

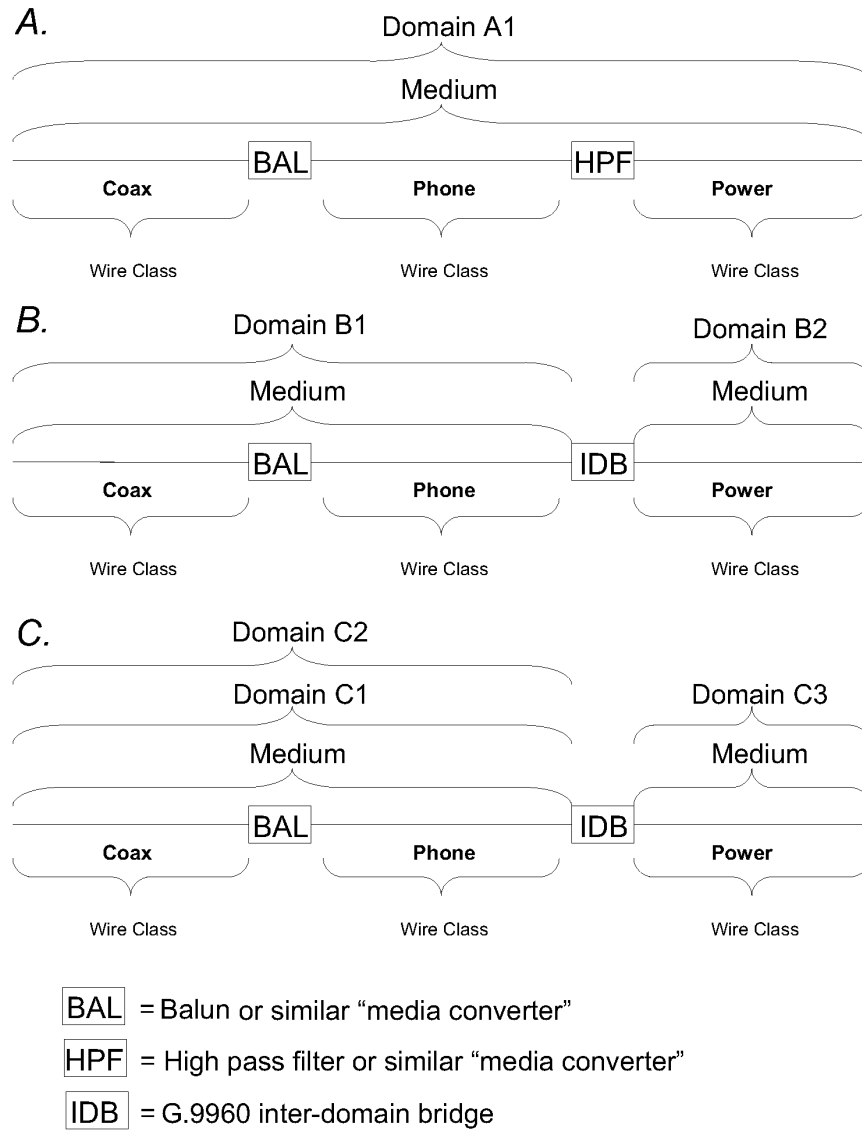

2219

2220

2221 **Figure I-2/G.9960 – Example network segments applying special use of the term, *medium***

2222

Appendix II: Examples of HN topologies

2223

2224

2225 An example of HN containing a single domain is shown in Figure II-1 where a single Domain
2226 Master coordinates nodes of the domain (i.e. assigns bandwidth resources and priority). In this
2227 example, the domain is bridged to the Access Network via the Node D (it is also a Domain Master)
2228 which is assumed to be part of the Residential Gateway. In PM nodes A, B, C, and D communicate
2229 directly to each other. In CM one of the nodes is assigned as DAP (Node D in this example), and all
2230 nodes can communicate to each other only via this node. In UM each of the nodes A-D can
2231 communicate directly to each other or indirectly, via other nodes operating as Relay nodes. In this
2232 example, Node D (Domain Master) serves as a Relay Node, while other nodes use either PP type of
2233 communication or Node D as a relay if required.

2234 While in either PM, CM or UM, nodes A-D can transmit under limitation of bandwidth resources
2235 and priorities assigned by the Domain Master.

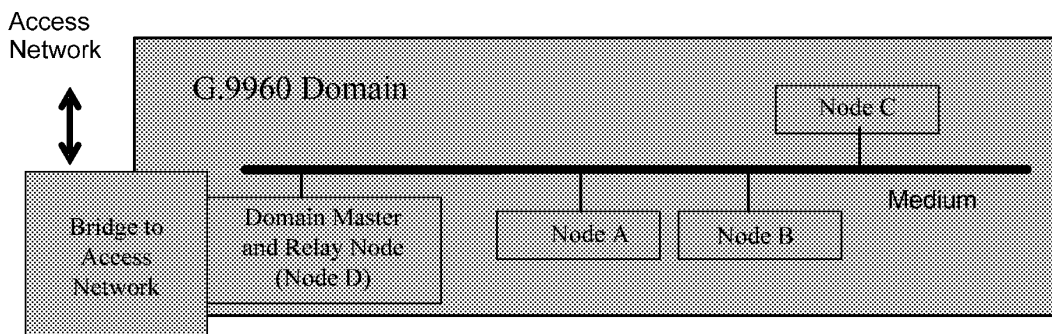

2236

2237

Figure II-1/G.9960 – Example of HN containing single domain

2238 An example of HN containing a single domain that operates in UM using both CTR and PP types of
2239 communication is depicted in Figure II-2. The subset of nodes that use CTR type of communication
2240 includes nodes B, C, D and F where Node D operates as a Relay node for this group of nodes. All
2241 other nodes can communicate directly (i.e., PP type) or via a Relay node (i.e., CTR type). A single
2242 Domain Master (in this case Node A) coordinates the HN nodes of the domain. The domain is
2243 bridged to the Access Network via Node A, which is assumed to be part of the Residential
2244 Gateway. While either using PP or CTR type of communication, Nodes A through G can transmit
2245 under the limitation of bandwidth resources and priorities assigned by the Domain Master. Packets
2246 from nodes B, C and F addressed to nodes outside the domain are sent to Node A via the relay Node
2247 D; Node A is connected to the inter-domain bridge. Packets from nodes D, E and G addressed to
2248 nodes outside the domain are sent to node A directly.

2249

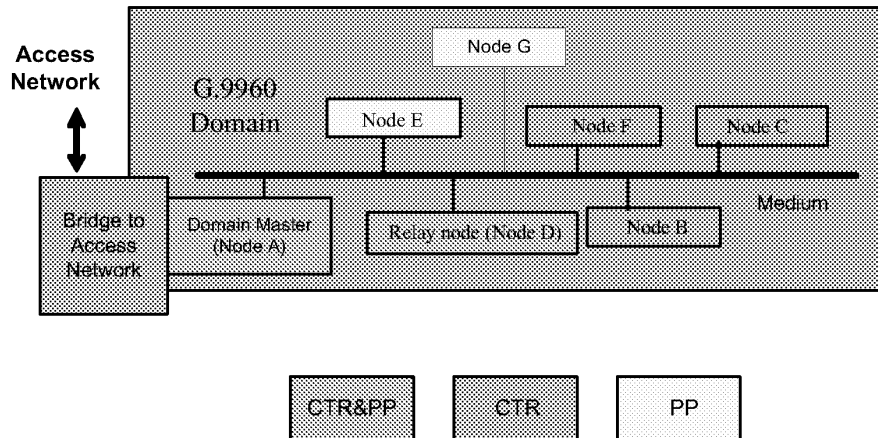
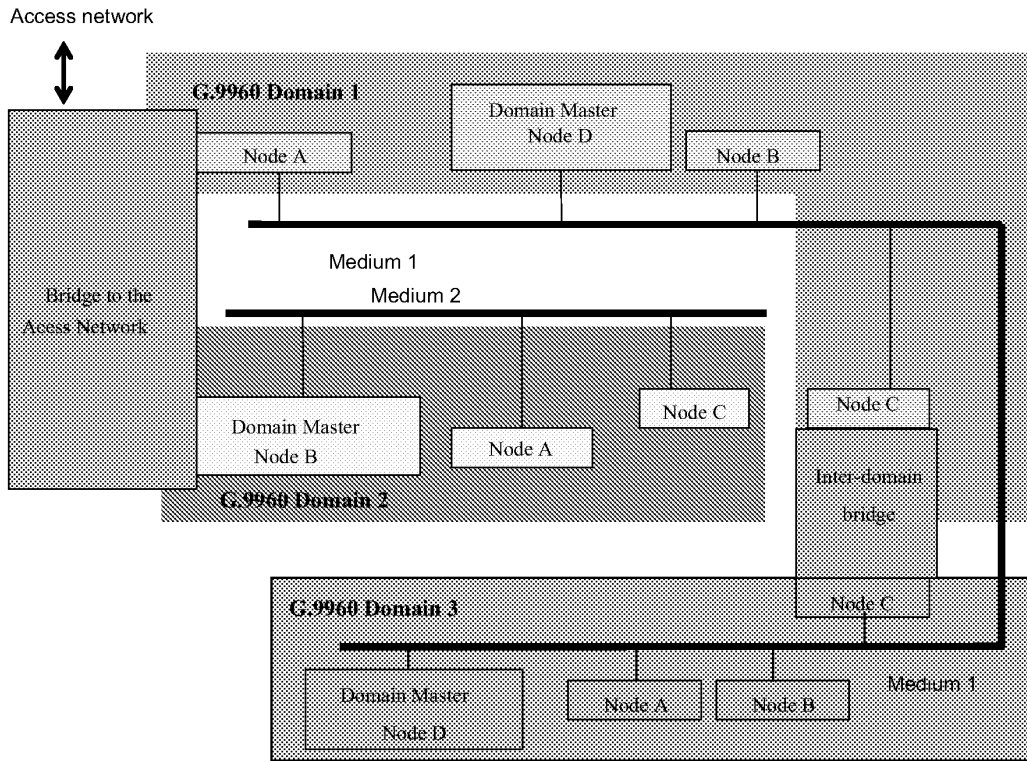

Figure II-2/G.9960 – Example of HN containing single domain using UM (combined PP& CTR)

An example of HN containing three domains with corresponding Domain Masters established on two different media is depicted in Figure II-3. Nodes of domain 1 and of domain 3 operate over the same medium (medium 1). In this example, it is assumed that domain 1 and domain 3 operate on different spectrum bands. Those two domains are bridged via an inter-domain bridge (on Layer 2 or Layer 3). Domain 2 operates on a different medium (denoted as medium 2). Domains 1 and 2 are bridged to the Access Network. In Figure II-3 it is assumed that the Domain Master of domain 2 and Node A of domain 1 are parts of the Residential Gateway. Domains 1 and 3 are connected by an inter-domain bridge. Each of three domains can operate in either PM, UM or CM mode of operation, independently of the operation mode used by other domains.



2262

2263

2264

Figure II-3/G.9960 – Example of HN comprising three domains

2265

2266

2267

2268

2269

2270

2271

2272

2273

2274

2275

2276

2277

2278

An example of a network containing HN and an Alien domain is shown in Figure II-4. The example shows an HN network containing two domains (domains 1 and 2) with corresponding Domain Masters established on two different media and bridged via an inter-domain bridge (Layer 2 or Layer 3). An Alien domain is established on the same medium as domain 1 and bridged to the HN (on Layer 2 or Layer 3). HN nodes of domain 1 and of domain 2 in Figure II-4 operate over different media, while nodes A1-A3 which are non-HN nodes, share the same medium with domain 1. The Domain Master of domain 1 considers the Alien domain as another network client connected to the corresponding HN node of domain 1. Operation of this Alien domain and its interconnection with HN is out of scope of G.9960.

In this example, Node A of domain 1 is bridged to the Access network. This bridge is usually a part of the Residential Gateway.

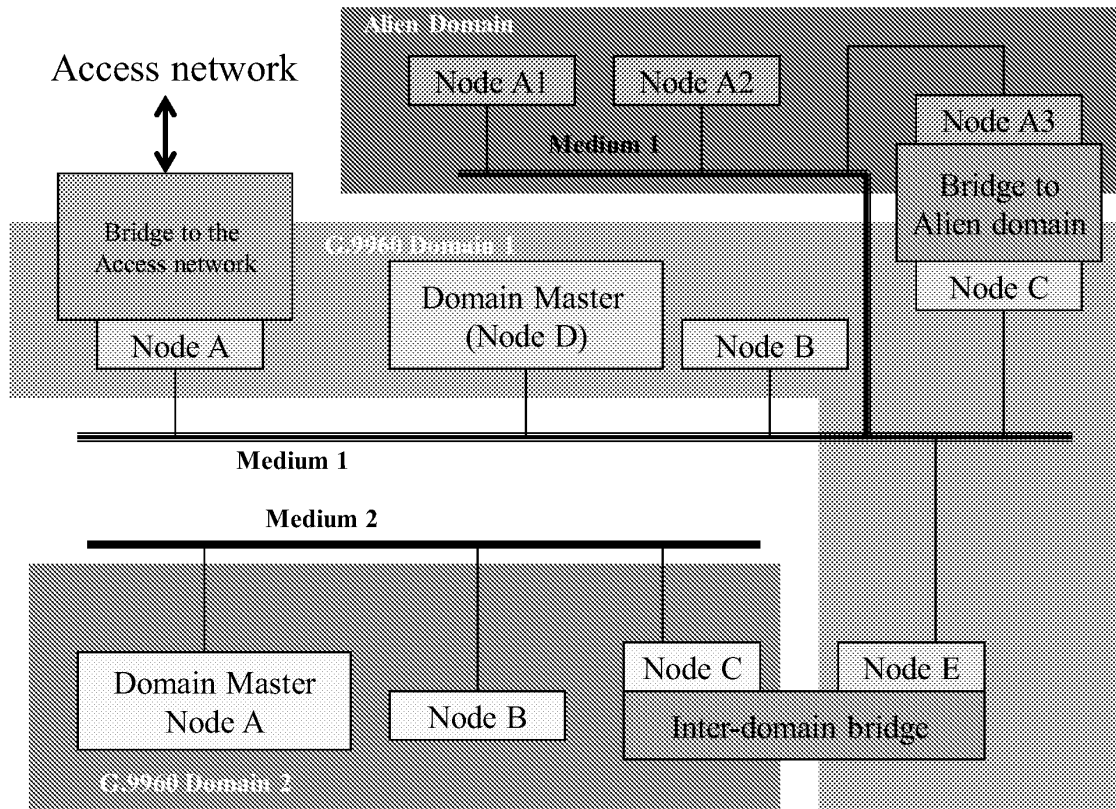

2279

2280

Figure II-4/G.9960 – Example of HN sharing medium with an Alien Domain

2281

2282 An example of HN as a part of residential broadband access is presented in Figure II-5. In the
2283 example, home network includes three domains established over coax, phone, and power line
2284 wiring. Alien domains of the network are established by the Residential Gateway and may include
2285 WLAN IEEE 802.11, USB2, and IEEE 802.3 (Ethernet). RG serves as a bridge allowing
2286 communication with Alien domains (e.g., 802.11) and with Access Network (e.g. PON or DSL).

2287 Each HN node in Figure II-5 is configured for the medium it is connected to. It can communicate
2288 with any other HN node of the same domain using either PP or CTR type of communication.
2289 Communication between HN nodes of different HN domains (e.g., between coax and phone line in
2290 Figure II-5) is via inter-domain bridges or via the RG. Communication with the nodes of Alien
2291 domains and with Access network is via bridges which are a part of RG.

2292

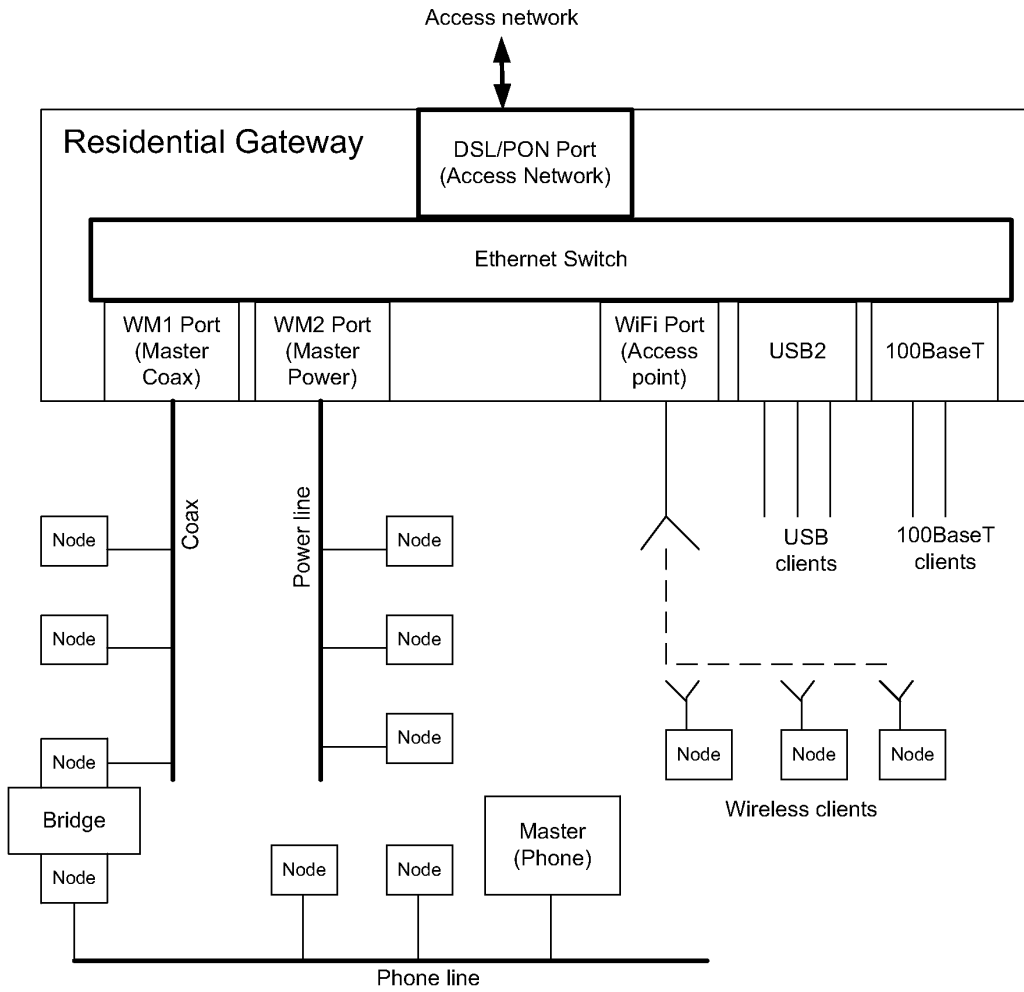

2293

2294

Figure II-5/G.9960 – Example of HN supporting residential broadband access

2295

2296

2297

Appendix III: Spectral usage

2298

2299 III.1 Scope

2300 This appendix describes information on spectral usage on each medium (coax cable, phone line
2301 and power line).

2302 III.2 Spectral usage in Japan

2303 III.2.1 Frequency allocation for coax

2304 There are mainly three types of services which are mapped to in-home coax medium:

- 2305 • Terrestrial broadcasting
- 2306 • Satellite broadcastings
- 2307 • CATV services

2308 The frequency allocations for all cases are shown in this clause.

2309 It should be noted that coaxial home network connected to cable access network should not
2310 interfere the services offered by the cable television operator to customers. The general use of the
2311 frequency by the cable television operator is 5 to 770MHz.

2312

2313 III.2.1.1 Terrestrial broadcast signal mapped to coax cable

2314 Table III-1 shows the frequency allocation for terrestrial TV broadcasting mapped to coax cable.
2315 Currently, both analog TV broadcasting (VHF/UHF) and digital TV broadcasting (UHF) are in
2316 service [1]. But analog TV broadcasting services will be discontinued on 24th July 2011 [2][3] and
2317 non-TV broadcasting and other telecommunications are planned to use these bands after that.
2318 G.9960 is one of the candidate services for empty bands if available, but this is for further study.

2319

2320
2321

Table III-1/G.9960 – Frequency allocation for terrestrial broadcast signals mapped to a coax cable

	Frequency [MHz]	Remarks
	90 – 108 *	<ul style="list-style-type: none"> • Used for analog TV broadcasting till 24th July 2011 • The use after 25th July 2011 is not determined at the time of publication • Retransmission of terrestrial digital TV broadcasting (OFDM)
	108 – 170 *	<ul style="list-style-type: none"> • Retransmission of terrestrial digital TV broadcasting (OFDM)
	170 – 222 *	<ul style="list-style-type: none"> • Used for analog TV broadcasting till 24th July 2011 • The use after 25th July 2011 is not determined at the time of publication • Retransmission of terrestrial digital TV broadcasting (OFDM)
	222 – 470 *	<ul style="list-style-type: none"> • Retransmission of terrestrial digital TV broadcasting (OFDM)
	470 – 710 *	<ul style="list-style-type: none"> • Used for analog TV broadcasting till 24th July 2011 • Used for digital TV broadcasting • Retransmission of terrestrial digital TV broadcasting (OFDM)
	710 – 770 *	<ul style="list-style-type: none"> • Used for TV broadcasting till 24th July 2012 • The use after 25th July 2012 is not determined at the time of publication • Retransmission of terrestrial digital TV broadcasting (OFDM)
* Frequency band usage for G.9960 including guard band is for further study.		

2322
2323

2324 **III.2.1.2 Broadcast Satellite (BS) and Communication Satellite (CS) signal mapped to**
2325 **coax cable**

2326 Satellite broadcastings (BS and CS) using around 12 GHz of frequency [1] are down-converted to
2327 intermediate frequency (BS-IF/CS-IF) at an antenna before transmission to a coax cable. The BS
2328 and CS need dedicated receiver antennas and there are various cases to use in-home coax cables
2329 depending on locations of antennas and connection points to in-home coax system. Basically, BS-
2330 IF/CS-IF signals come from an antenna or CATV. Table III-2 shows satellite broadcast signals
2331 mapped to a coax cable.

2332

2333 **Table III-2/G.9960 – Frequency allocation for satellite broadcast signals mapped to a coax**
2334 **cable**

Broadcast satellite services	BS-IF/CS-IF [MHz]	Remarks
BS *	1035.95 – 1331.50	BS-IF transmission
110° CS *	1596 – 2070	CS-IF transmission
JC SAT-3,4 *	968 – 2055	CS-IF transmission
Superbird C *	1020 – 2040	CS-IF transmission
* Frequency band usage for G.9960 including guard band is for further study.		

2335

2336

2337 **III.2.1.3 CATV services on coax cable**

2338 Table III-3 shows the frequency allocation of other services [4][5]. Since frequencies below
2339 770MHz are currently used for various services listed in Table III-3, the usage for other services
2340 such as G.9960 is for further study.

2341

2342

Table III-3/G.9960 – Frequency allocation of other services on coax cable

Frequency [MHz]	Usage	Remarks
5 – 60 *	<ul style="list-style-type: none"> Upstream CATV signal (cable internet signal, VoIP, VOD, relay broadcast, pilot signal etc.) 	<ul style="list-style-type: none"> Being used for Cable Modem(CM) up-stream signals [6][7][8] Being used for control signals between CM and Cable Modem Termination
70 – 76 *	<ul style="list-style-type: none"> Downstream pilot signal, analog HT (Home Terminal) control signal, monitoring signal of amplifier 	<ul style="list-style-type: none"> Being used for Cable Modem(CM) up-stream signals [6][7][8]
76 – 90 *	<ul style="list-style-type: none"> Retransmission of radio broadcasting on cable (FM radio signal) 	<ul style="list-style-type: none"> Being used for Cable Modem(CM) up-stream signals [8]
90 – 770 *	<ul style="list-style-type: none"> Analog cable broadcasting (NTSC-VSB) Digital cable broadcasting (64/256QAM) Retransmission of terrestrial analogTV broadcasting (NTSC-VSB) Retransmission of terrestrial digital TV broadcasting (OFDM) Downstream cable internet signal, VoIP, VOD control signal etc. 	<ul style="list-style-type: none"> Covered by regulation [4]
770 – 1035 **	<ul style="list-style-type: none"> Other home network services 	
1035 – 2070 *	<ul style="list-style-type: none"> BS-IF/CS-IF retransmission 	
>2070 **	<ul style="list-style-type: none"> Currently not in use at the time of publication 	
<p>* Frequency band usage for G.9960 including guard band is for further study. ** Candidate frequency band for G.9960 including guard band.</p>		

2343

2344 **III.2.2 Frequency allocation for phone line**

2345 (For further study)

2346

2347 **III.2.3 Frequency allocation for power line**

2348 (For further study)

2349 **III.2.4 Bibliography**

2350 [1] Spectrum Charts, Ministry of Internal Affairs and Communications,
2351 <http://www.tele.soumu.go.jp/e/search/myuse/use0303/index.htm>

- 2352 [2] Schedule, Ministry of Internal Affairs and Communications,
2353 http://www.soumu.go.jp/joho_tsusin/whatsnew/digital-broad/when_en.html
- 2354 [3] Announcement of channel plan for terrestrial digital TV broadcasting, Ministry of Internal
2355 Affairs and Communications (Japanese), http://www.soumu.go.jp/s-news/2008/080331_11.html
- 2356 [4] Cable Television Broadcast Law (Japanese), [http://law.e-](http://law.e-gov.go.jp/htmldata/S47/S47F04001000040.html)
2357 [gov.go.jp/htmldata/S47/S47F04001000040.html](http://law.e-gov.go.jp/htmldata/S47/S47F04001000040.html)
- 2358 [5] STD-013-2.0, “Transmission System for MDU”, Japan Cable Television Engineering
2359 Association (JCTEA) (Japanese), <http://www.catv.or.jp/jctea/>
- 2360 [6] ITU-T Rec.J.112 “Transmission systems for interactive cable television services”
- 2361 [7] ITU-T Rec.J.122 “Second-generation transmission systems for interactive cable television
2362 services – IP cable modems”
- 2363 [8] ITU-T Rec. J.222.1 “Third-generation transmission systems for interactive cable television
2364 services – IP cable modems: Physical layer specification”
- 2365
- 2366
- 2367

2368

2369

Appendix IV - Priority Mapping

2370

2371 Priority mapping recommended by IEEE 802.1D (sub-clause 7.7.3) are presented in Table IV-1.

2372

2373

Table IV-1: Recommended Flow Priority to Priority Queue Mappings according to 802.1D

		Number of Available Traffic Classes							
		1	2	3	4	5	6	7	8
User Priority	0 (default)	0	0	0	1	1	1	1	2
	1	0	0	0	0	0	0	0	0
	2	0	0	0	0	0	0	0	1
	3	0	0	0	1	1	2	2	3
	4	0	1	1	2	2	3	3	4
	5	0	1	1	2	3	4	4	5
	6	0	1	2	3	4	5	5	6
	7	0	1	2	3	4	5	6	7

2374

2375

Electronic Patent Application Fee Transmittal

Application Number:				
Filing Date:				
Title of Invention:	Header Repetition Scheme in Packet-based OFDM Systems			
First Named Inventor/Applicant Name:	Joon Bae Kim			
Filer:	Jason Vick/Joanne Vos			
Attorney Docket Number:	5550-87-PROV			
Filed as Large Entity				
Provisional Filing Fees				
Description	Fee Code	Quantity	Amount	Sub-Total in USD(\$)
Basic Filing:				
Provisional application filing	1005	1	220	220
Pages:				
Claims:				
Miscellaneous-Filing:				
Petition:				
Patent-Appeals-and-Interference:				
Post-Allowance-and-Post-Issuance:				
Extension-of-Time:				

Description	Fee Code	Quantity	Amount	Sub-Total in USD(\$)
Miscellaneous:				
Total in USD (\$)				220

Electronic Acknowledgement Receipt

EFS ID:	5933709
Application Number:	61235909
International Application Number:	
Confirmation Number:	1550
Title of Invention:	Header Repetition Scheme in Packet-based OFDM Systems
First Named Inventor/Applicant Name:	Joon Bae Kim
Customer Number:	62574
Filer:	Jason Vick/Joanne Vos
Filer Authorized By:	Jason Vick
Attorney Docket Number:	5550-87-PROV
Receipt Date:	21-AUG-2009
Filing Date:	
Time Stamp:	16:50:47
Application Type:	Provisional

Payment information:

Submitted with Payment	yes
Payment Type	Deposit Account
Payment was successfully received in RAM	\$220
RAM confirmation Number	2272
Deposit Account	191970
Authorized User	

The Director of the USPTO is hereby authorized to charge indicated fees and credit any overpayment as follows:
 Charge any Additional Fees required under 37 C.F.R. Section 1.16 (National application filing, search, and examination fees)
 Charge any Additional Fees required under 37 C.F.R. Section 1.17 (Patent application and reexamination processing fees)

Charge any Additional Fees required under 37 C.F.R. Section 1.19 (Document supply fees)

Charge any Additional Fees required under 37 C.F.R. Section 1.21 (Miscellaneous fees and charges)

File Listing:

Document Number	Document Description	File Name	File Size(Bytes)/ Message Digest	Multi Part /.zip	Pages (if appl.)
1	Provisional Cover Sheet (SB16)	PROV_Cover_Sheet.pdf	1000376 f36ad4a3a883de80a71e3a1a05699d6e343cae1b	no	3

Warnings:

Information:

2	Specification	Specificationv3.pdf	768521 3628b92da039c676ec5c810a5e640e3d98c9122e	no	126
---	---------------	---------------------	--	----	-----

Warnings:

Information:

3	Fee Worksheet (PTO-875)	fee-info.pdf	29280 1f212f36f7ab032ea17056800a805bc847d65dda	no	2
---	-------------------------	--------------	---	----	---

Warnings:

Information:

Total Files Size (in bytes): 1798177

This Acknowledgement Receipt evidences receipt on the noted date by the USPTO of the indicated documents, characterized by the applicant, and including page counts, where applicable. It serves as evidence of receipt similar to a Post Card, as described in MPEP 503.

New Applications Under 35 U.S.C. 111

If a new application is being filed and the application includes the necessary components for a filing date (see 37 CFR 1.53(b)-(d) and MPEP 506), a Filing Receipt (37 CFR 1.54) will be issued in due course and the date shown on this Acknowledgement Receipt will establish the filing date of the application.

National Stage of an International Application under 35 U.S.C. 371

If a timely submission to enter the national stage of an international application is compliant with the conditions of 35 U.S.C. 371 and other applicable requirements a Form PCT/DO/EO/903 indicating acceptance of the application as a national stage submission under 35 U.S.C. 371 will be issued in addition to the Filing Receipt, in due course.

New International Application Filed with the USPTO as a Receiving Office

If a new international application is being filed and the international application includes the necessary components for an international filing date (see PCT Article 11 and MPEP 1810), a Notification of the International Application Number and of the International Filing Date (Form PCT/RO/105) will be issued in due course, subject to prescriptions concerning national security, and the date shown on this Acknowledgement Receipt will establish the international filing date of the application.