



IS NOW PART OF



uPI SEMI

Please visit our website for more information: www.upi-semi.com

The contents of this document are provided in connection with uPI Semiconductor Corp. ("uPI") products. uPI makes no representations or warranties with respect to the accuracy or completeness of the contents of this publication and reserves the right to make changes to specifications and product descriptions at any time without notice.

No license, whether express, implied, arising by estoppel or otherwise, to any intellectual property rights, is granted by this publication. Except as provided in uPI' s terms and conditions of sale for such products, uPI assumes no liability whatsoever, and uPI disclaims any express or implied warranty relating to sale and/or use of uPI products, including liability or warranties relating to fitness for a particular purpose, merchantability, or infringement of any patent, copyright or other intellectual property right. uPI products are not designed, intended, authorized or warranted for use as components in systems intended for medical, life-saving, or life sustaining applications. uPI reserves the right to discontinue or make changes to its products at any time without notice.

uPI, uPI design logo, and combinations thereof, are trademarks or registered trademarks of uPI Semiconductor Corp. Other product names used in this publication are for identification purposes only and may be trademarks of their respective companies.

QM3016AM3

N-Channel 30V Fast Switching MOSFET

General Description

The QM3016AM3 is a high performance trench N-channel MOSFET which utilizes extremely high cell density to provide low $R_{DS(on)}$ and gate charge characteristics. It is ideally suited to support synchronous buck converter applications.

The QM3016AM3 meets RoHS and Green Product requirements while supporting full function reliability.

Features

- ✓ Advanced high cell density Trench technology
- ✓ Super Low Gate Charge
- ✓ Excellent CdV/dt effect decline
- ✓ Green Device Available

Product Summary

V_{DS}	$R_{DS(ON)}$ max ($V_{GS}=10V$)	I_D ($T_c=25\text{ }^\circ\text{C}$)
30V	4m Ω	72A

Applications

- ✓ High Frequency Point-of-Load Synchronous Buck Converter for MB/NB/UMPC/VGA
- ✓ Load Switch
- ✓ Networking DC-DC Power System

Pin Configuration

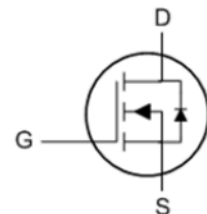
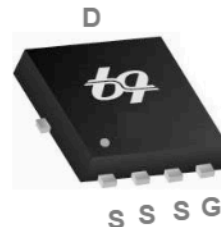

Ordering Information

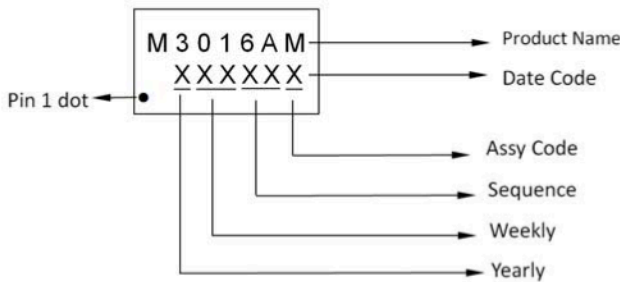
Order Number	Package Type	Top Marking
QM3016AM3	PRPAK3X3	

QM3016AM3

Absolute Maximum Ratings

Symbol	Parameter	Rating	Units
V_{DS}	Drain-Source Voltage	30	V
V_{GS}	Gate-Source Voltage	± 20	V
$I_{D@T_C=25^\circ C}$	Continuous Drain Current, V_{GS} @ 10V ¹	72	A
$I_{D@T_C=100^\circ C}$	Continuous Drain Current, V_{GS} @ 10V ¹	46	A
$I_{D@T_A=25^\circ C}$	Continuous Drain Current, V_{GS} @ 10V ¹	15	A
$I_{D@T_A=70^\circ C}$	Continuous Drain Current, V_{GS} @ 10V ¹	12	A
I_{DM}	Pulsed Drain Current ²	144	A
EAS	Single Pulse Avalanche Energy ³	108.1	mJ
I_{AS}	Avalanche Current	46.5	A
$P_{D@T_C=25^\circ C}$	Total Power Dissipation ⁴	36.7	W
$P_{D@T_A=25^\circ C}$	Total Power Dissipation ⁴	1.67	W
T_{STG}	Storage Temperature Range	-55 to 150	$^\circ C$
T_J	Operating Junction Temperature Range	-55 to 150	$^\circ C$

Thermal Data

Symbol	Parameter	Typ.	Max.	Unit
$R_{\theta JA}$	Thermal Resistance Junction-Ambient ¹	--	75	$^\circ C/W$
$R_{\theta JC}$	Thermal Resistance Junction-Case ¹	--	3.4	$^\circ C/W$

QM3016AM3

N-Channel Electrical Characteristics

N-Channel Electrical Characteristics: (T _J =25 °C, unless otherwise noted)						
Symbol	Parameter	Conditions	Min	Typ	Max	Unit
BV _{DSS}	Drain-Source Breakdown Voltage	V _{GS} =0V, I _D =250uA	30	--	--	V
ΔBV _{DSS} / ΔT _J	BVDSS Temperature Coefficient	Reference to 25°C, I _D =1mA	--	0.027	--	V/°C
R _{DS(ON)}	Static Drain-Source On-Resistance ²	V _{GS} =10V, I _D =20A	--	3.4	4.0	mΩ
		V _{GS} =4.5V, I _D =10A	--	5.2	6.0	
V _{GS(th)}	Gate Threshold Voltage	V _{GS} =V _{DS} , I _D =250uA	1.2	1.5	2.5	V
ΔV _{GS(th)}	V _{GS(th)} Temperature Coefficient		--	-4.2	--	mV/°C
I _{DSS}	Drain-Source Leakage Current	V _{DS} =24V, V _{GS} =0V, T _J =25°C	--	--	1	uA
		V _{DS} =24V, V _{GS} =0V, T _J =55°C	--	--	5	
		V _{DS} =30V, V _{GS} =0V, T _J =25°C	--	--	10	
I _{GSS}	Gate-Source Leakage Current	V _{GS} =±20V, V _{DS} =0V	--	--	±100	nA
g _{fs}	Forward Transconductance	V _{DS} =5V, I _D =20A	--	45	--	S
R _g	Gate Resistance	V _{DS} =0V, V _{GS} =0V, f=1MHz	--	4.4	--	Ω
Q _g	Total Gate Charge (10V)	V _{DS} =20V, V _{GS} =10V, I _D =10A	--	52.4	--	nC
Q _g	Total Gate Charge (4.5V)	V _{DS} =20V, V _{GS} =4.5V, I _D =10A	--	27.0	--	
Q _{gs}	Gate-Source Charge		--	5.2	--	
Q _{gd}	Gate-Drain Charge		--	11.9	--	
t _{d(on)}	Turn-On Delay Time	V _{DS} =15V, V _{GS} =10V, R _G =1.5Ω I _D =20A	--	9.3	--	ns
t _r	Rise Time		--	33.9	--	
t _{d(off)}	Turn-Off Delay Time		--	67.0	--	
t _f	Fall Time		--	16.7	--	
C _{iss}	Input Capacitance	V _{DS} =15V, V _{GS} =0V, f=1MHz	--	2430	--	pF
C _{oss}	Output Capacitance		--	256	--	
C _{rss}	Reverse Transfer Capacitance		--	235	--	

QM3016AM3

Guaranteed Avalanche Characteristics

Symbol	Parameter	Conditions	Min.	Typ.	Max.	Unit
EAS	Single Pulse Avalanche Energy ⁵	$V_{DD}=25V$, $L=0.1mH$, $I_{AS}=33A$	54.5	--	--	mJ

Diode Characteristics

Symbol	Parameter	Conditions	Min.	Typ.	Max.	Unit
I_S	Continuous Source Current ^{1,6}	$V_G=V_D=0V$, Force Current	--	--	72	A
I_{SM}	Pulsed Source Current ^{2,6}		--	--	144	A
V_{SD}	Diode Forward Voltage ²	$V_{GS}=0V$, $I_S=1A$, $T_J=25^\circ C$	--	--	1.0	V
t_{rr}	Reverse Recovery Time	$I_F=20A$, $di/dt=100A/\mu s$, $T_J=25^\circ C$	--	14	--	nS
Q_{rr}	Reverse Recovery Charge		--	6.8	--	nC

Note:

1. Test data conducted with surface mount attachment to 1 inch², FR-4 board utilizing 2oz copper
2. Pulse Test. Pulse width $\leq 300\mu s$, duty cycle $\leq 2\%$
3. EAS data is a maximum rating. The test condition is $V_{DD}=25V$, $V_{GS}=10V$, $L=0.1mH$
4. The power dissipation is limited by a 150°C maximum junction temperature
5. The Min. value is 100% EAS tested guarantee
6. The data is theoretically the same as I_D and I_{DM} . In real applications, it will be limited by total power

QM3016AM3

Typical Characteristics

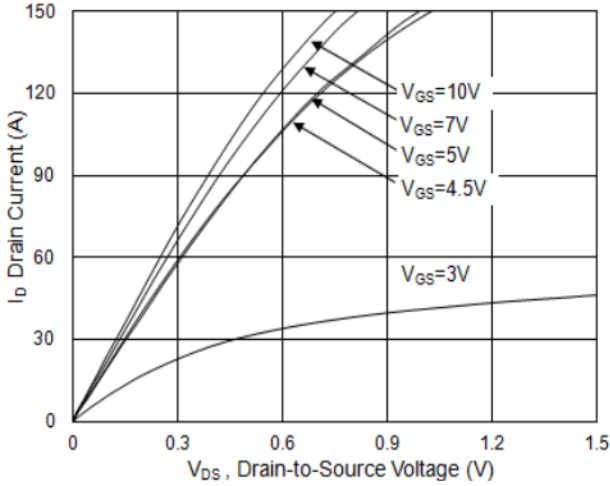

Fig.1: Typical Output Characteristics

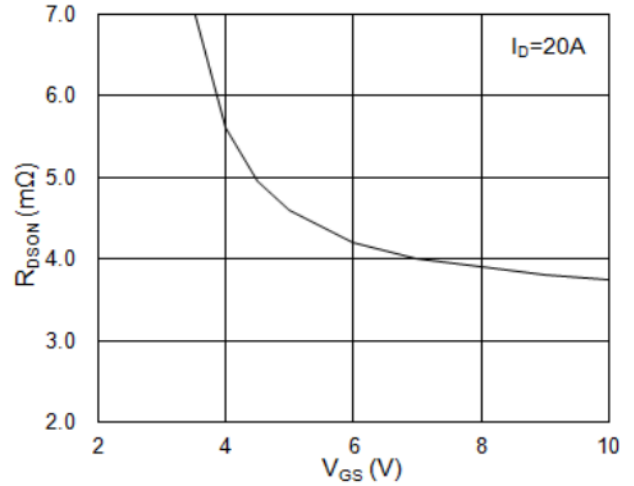

Fig.2: On-Resistance vs. Gate-Source

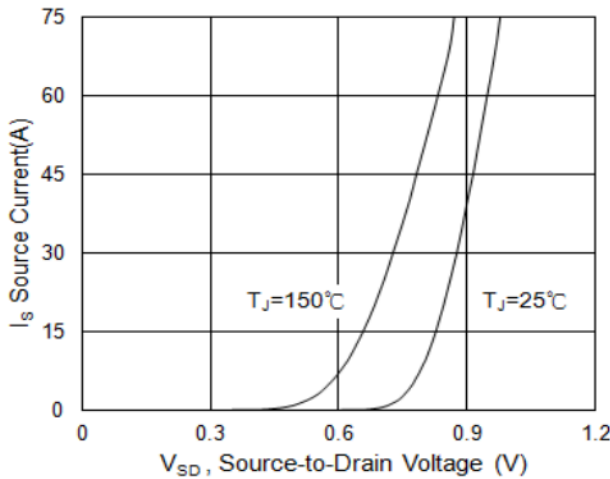

Fig.3: Forward Characteristics of Reverse

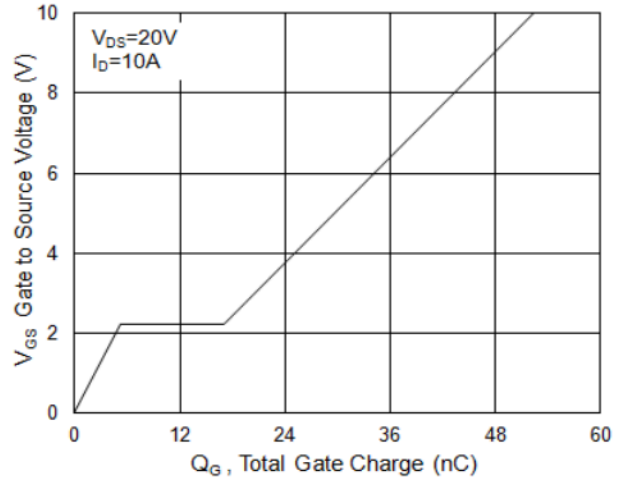

Fig.4: Gate-Charge Characteristics

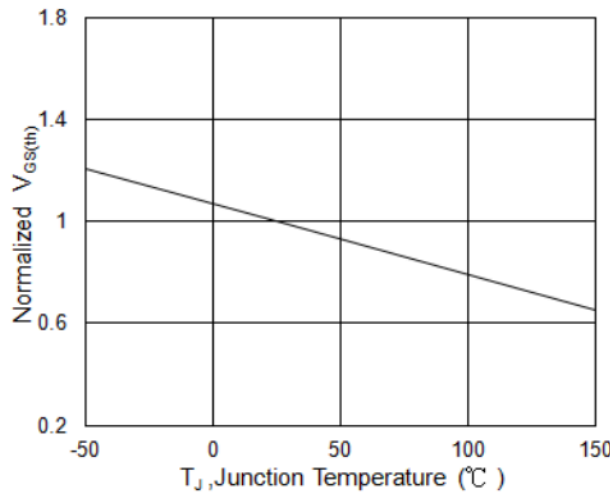

Fig.5: Normalized $V_{GS(th)}$ vs. T_J

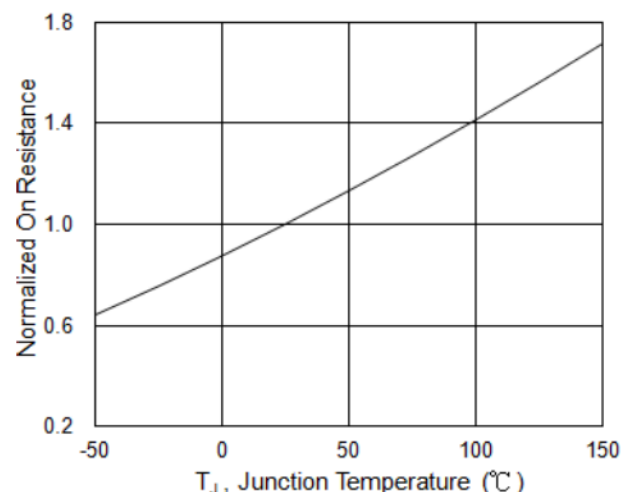

Fig.6: Normalized $R_{DS(on)}$ vs. T_J

QM3016AM3

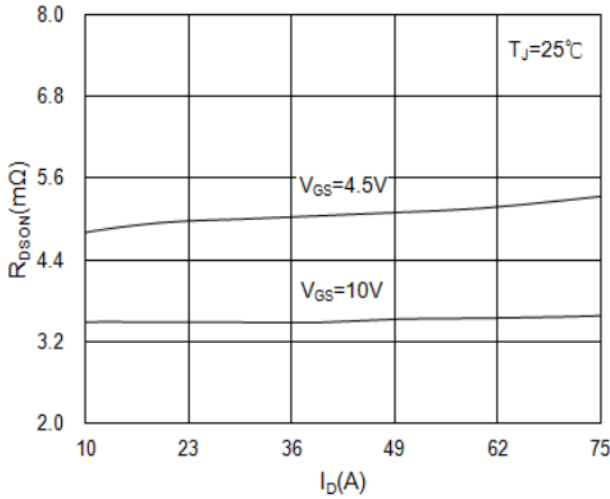

Fig. 7: Drain-Source On-State Resistance

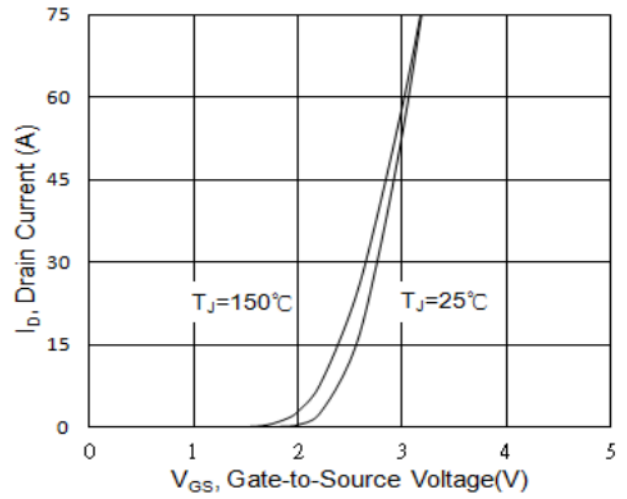

Fig. 8: Transfer Characteristics

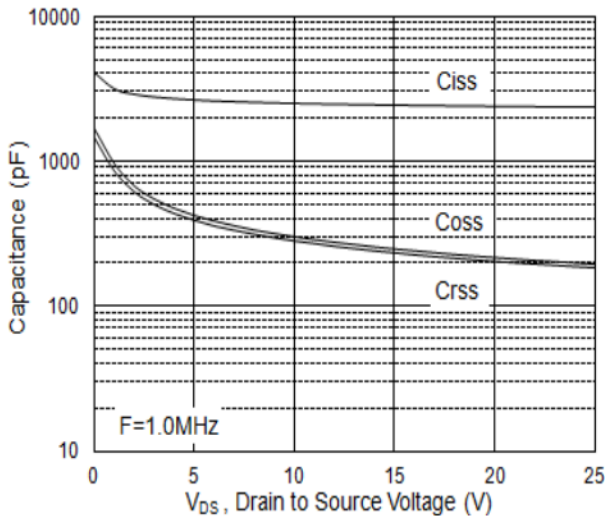

Fig. 9: Capacitance

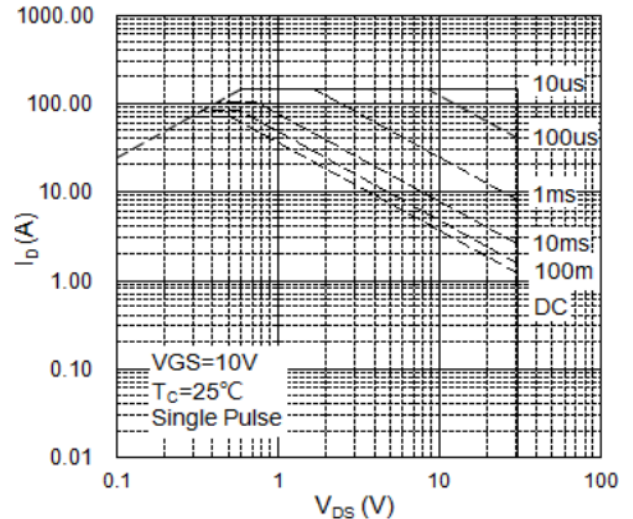

Fig. 10: Safe Operating Area

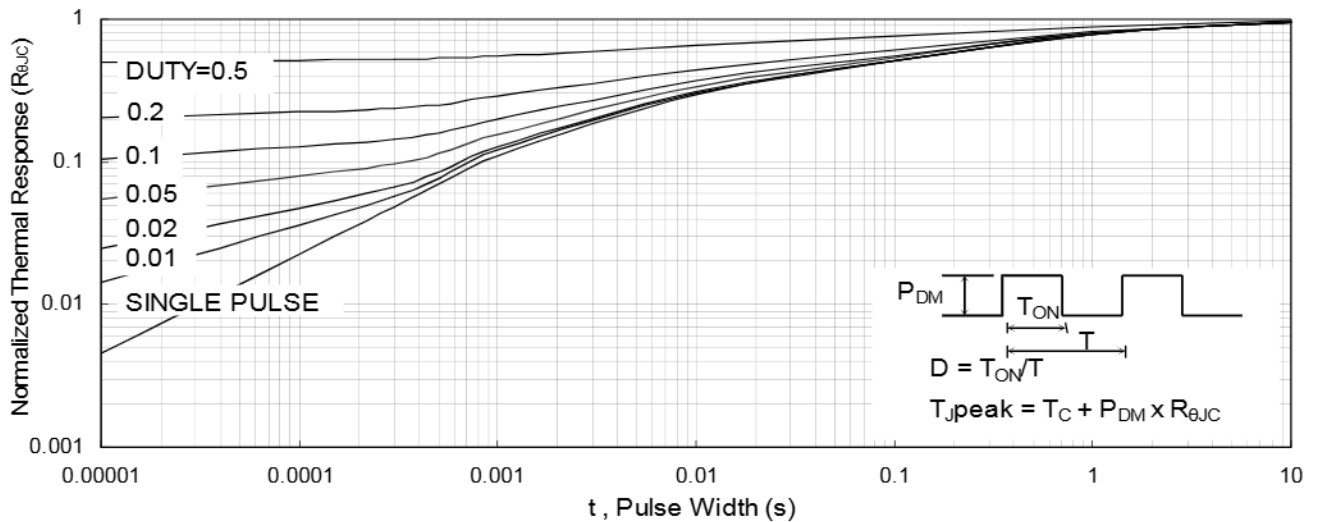

Fig. 11: Normalized Maximum Transient Thermal Impedance

QM3016AM3

Legal Notice

The contents of this document are provided in connection with uPI Semiconductor Corp. (“uPI”) products. uPI makes no representations or warranties with respect to the accuracy or completeness of the contents of this publication and reserves the right to make changes to specifications and product descriptions at any time without notice.

No license, whether express, implied, arising by estoppel or otherwise, to any intellectual property rights, is granted by this publication. Except as provided in uPI’s terms and conditions of sale for such products, uPI assumes no liability whatsoever, and uPI disclaims any express or implied warranty relating to sale and/or use of uPI products, including liability or warranties relating to fitness for a particular purpose, merchantability, or infringement of any patent, copyright or other intellectual property right. uPI products are not designed, intended, authorized or warranted for use as components in systems intended for medical, life-saving, or life sustaining applications. uPI reserves the right to discontinue or make changes to its products at any time without notice.

Copyright© 2019, uPI Semiconductor Corp. All rights reserved.
uPI, uPI design logo, and combinations thereof, are trademarks or registered trademarks of uPI Semiconductor Corp.

Other product names used in this publication are for identification purposes only and may be trademarks of their respective companies.



uPI Semiconductor Corp.

9F.,No.5, Taiyuan 1st St. Zhubei City, Hsinchu, Taiwan, R.O.C.

TEL : 886.3.560.1666 FAX : 886.3.560.1888