

**IN THE UNITED STATES DISTRICT COURT
FOR THE EASTERN DISTRICT OF TEXAS
MARSHALL DIVISION**

FORCE MOS TECHNOLOGY, CO., LTD,)	
)	
Plaintiff,)	Civil Action No. 2:22-cv-00460
)	
v.)	
)	JURY TRIAL DEMAND
ASUSTEK COMPUTER, INC.)	
)	
Defendant.)	
)	

FIRST AMENDED COMPLAINT FOR PATENT INFRINGEMENT

Plaintiff Force MOS Technology, Co., Ltd, (“Force MOS”) files this First Amended Complaint for Patent Infringement and Demand for Jury Trial against ASUSTek Computer, Inc. (“ASUS”) for infringement of United States Patent Nos. 7,629,634; 7,847,346; and 7,812,409 (collectively the “Patents-in-Suit”).

THE PARTIES

1. Force MOS is a limited company organized and existing under the laws of Taiwan and located at 24F, No. 555, Siyuan Road, Xinzhuang District, New Taipei City, Taiwan (R.O.C).

2. ASUS is a corporation organized and existing under the laws of Taiwan, with a principle place of business at No. 15, Li-Te Road, Beitou District, Taipei 112, Taiwan and may be served pursuant to the provisions of the Hague Convention.

JURISDICTION AND VENUE

3. This is an action for patent infringement arising under the patent laws of the United States, Title 35, United States Code, including 35 U.S.C. §§ 154, 271, 281, and 283-285.

4. This Court has exclusive subject matter jurisdiction over this case for patent infringement under 28 U.S.C. §§ 1331 and 1338.

5. ASUS is subject to the general and specific personal jurisdiction of this Court, based upon its regularly conducted business in the State of Texas and in the Eastern District of Texas (“District”), including conduct giving rise to this action.

6. ASUS has conducted and does conduct business within the State of Texas.

7. Upon information and belief, ASUS has sold infringing products, systems, and services in the Eastern District of Texas.

8. Upon information and belief, ASUS has sold the products, systems, and services accused of infringement in the Eastern District of Texas through its website at <https://store.asus.com/us/>.

9. This Court has personal jurisdiction over ASUS at least because ASUS has made, used, offered to sell, sold, or put into service the accused products, systems, or services within the District, either directly or through its website, thus committing, acts of infringement within the District, and placed infringing products, systems, or services into the stream of commerce knowing or understanding that such products, systems, or services would be used in the United States, including in the Eastern District of Texas.

10. Venue is proper in this Court pursuant to 28 U.S.C. §§ 1400(b) and 1391(c)(3) because ASUS is a foreign corporation subject to suit in any district.

11. ASUS has previously consented to jurisdiction and venue in this District, for example, in *Genghiscomm Holdings, LLC v. ASUSTek Computer, Inc.*, Case No. 2:22-cv-66 (E.D. Tex. 2022).

THE '634 PATENT

12. Force MOS is the owner by assignment from the inventor Fu-Yuan Hsieh of all right, title, and interest in and to United States Patent No. 7,629,634 (the “'634 Patent”) titled “Trenched Mosfet with Trenched Source Contact” including the right to sue for all past, present, and future infringement. A true and correct copy of the '634 Patent is attached to this Complaint at Exhibit A.

13. The '634 Patent issued from U.S. Patent Application No. 12/036,243 filed on February 23, 2008.

14. The Patent Office issued the '634 Patent on December 8, 2009, after a full and fair examination.

15. The '634 Patent is valid and enforceable.

16. The '634 Patent relates to a trench MOSFET (Metal-Oxide-Semiconductor Field Effect Transistor) comprised of a barrier metal layer and a plurality of contact metal plugs which provides a new structure of trench MOSFET over the prior art.

17. The inventors of the '634 Patent recognized that, in a traditional trench MOSFET design, the sidewall of the source contact trench has no ohmic contact with the contact metal plug which results in poor performance during Unclamp Inductance Switching test. When P base resistance from the channel to the contact metal plug is high enough, device destruction can occur.

18. The '634 Patent provides several advantages over the prior art such as providing a good ohmic contact to the sidewall of the source contact which results in the based resistance R_p between the channel and source contact trench being reduced.

THE '346 PATENT

21. Force MOS is the owner by assignment from the inventors Fu-Yuan Hsieh and Ming-Tao Chung of all right, title, and interest in and to United States Patent No. 7,847,346 (the “'346 Patent”) titled “Trenched Mosfet with Trench Source Contact Having Copper Wire Bonding” including the right to sue for all past, present, and future infringement. A true and correct copy of the '346 Patent is attached to this Complaint at Exhibit B.

22. The '346 Patent issued from U.S. Patent Application No. 12/292,780 filed on November 26, 2008.

23. The Patent Office issued the '346 Patent on December 7, 2010, after a full and fair examination.

24. The '346 Patent is valid and enforceable.

25. The '346 Patent relates to a trenched MOSFET (Metal-Oxide- Semiconductor Field Effect Transistor) employing copper wire bonding.

26. The inventors of the '346 Patent recognized that, in a traditional trenched MOSFET design, a thick metal layer was required to reduce the distributed resistance of the source metal layer. This thick metal layer provides essentially no resistance between the transistor cells, which dramatically reduces the overall spreading resistance. The problem, as recognized by the '346 Patent's inventors, was that this reduction in spreading resistance came at the cost of a much larger surface area than necessary, along with a corresponding increase in fabrication costs.

27. The '346 Patent provides several advantages over the prior art such as reducing die size from 30%-70% over traditional trench MOSFET designs and reducing spreading resistance without adding the thick metal layer which are typically made of Ni/Au.

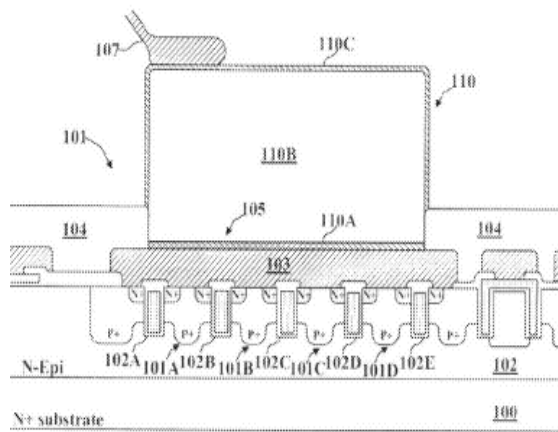

Fig. 1 (PRIOR ART)

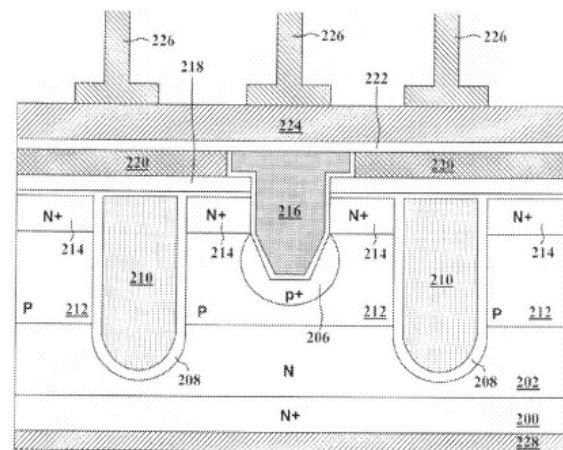

Fig. 2

28. The '346 Patent describes and claims a specific way to improve the trench MOSFET cell and manufacture process by including vertical contact trench sidewalls within the contact insulating layer and using copper wire bonding to replace Au wire and the corresponding requirement of thick Al alloys.

29. Claim 1 of the '346 Patent reads:

1. A trench MOSFET comprising a plurality of semiconductor power cells with each cell comprising a plurality of trench gates surrounded by a plurality of source regions of a first type conductivity above a plurality of body regions of second type conductivity above a drain region disposed on a bottom surface of a substrate, said trench MOSFET further comprising:

- a substrate of said first type conductivity;
- an epitaxial layer of said first type conductivity over said substrate, having a lower doping concentration than said substrate;
- a plurality of trenches extending into said epitaxial layer, surrounded by a plurality of said source regions of said first type conductivity above said body regions of said second type conductivity;
- a first insulating layer lining said trenches as gate oxide;
- a doped polysilicon of said first type conductivity as said trench gates overlying said first insulating layer;
- a second insulating layer disposed over said epitaxial layer to isolate a source metal which contacts said both source and body regions, from said doped polysilicon as said trench gates;
- a plurality of source contact trenches penetrating through said second insulating layer and said source regions with vertical sidewalls substantially perpendicular to a top epitaxial surface within said source regions, and

further extending into said body regions with tapered sidewalls with respect to said top surface of said epitaxial layer;
a front metal disposed on the front surface of said trench MOSFET as said source metal;
a backside metal disposed on the backside of said substrate as a drain metal;
at least one copper wire electrically bonded to said source metal.

THE '409 PATENT

30. Force MOS is the owner by assignment from the inventor Fwu-Iuan Hshieh of all right, title, and interest in and to United States Patent No. 7,812,409 (the "'409 Patent") titled "Trenched Mosfet with Cell Layout, Ruggedness, Truncated Corners" including the right to sue for all past, present, and future infringement. A true and correct copy of the '409 Patent is attached to this Complaint at Exhibit C.

31. The '409 Patent issued from U.S. Patent Application No. 11/633,366 filed on December 4, 2006.

32. The Patent Office issued the '409 Patent on October 12, 2010, after a full and fair examination.

33. The '409 Patent is valid and enforceable.

34. The '409 Patent relates to an improved cell structure, device configuration, and improved fabrication process for a trenched semiconductor power device with improved ruggedness with truncated corners.

35. The inventor of the '409 Patent recognized that, in traditional trenched semiconductor devices, there is a problem with parasitic bipolar NPN latch up. This problem is particularly acute near the trench corners. The problem, as recognized by the '409 Patent's inventor, was that the weak points at these four corners, which result in low avalanche current, lead to reduced ruggedness due to the parasitic N+PN latches near the trench corners.

36. The '409 Patent provides several advantages over the prior art such as making the space between the trenched gate and metal contact more uniform which enhances the ruggedness of the device.

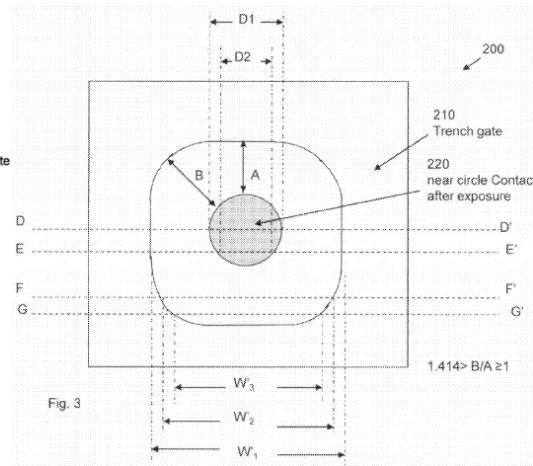
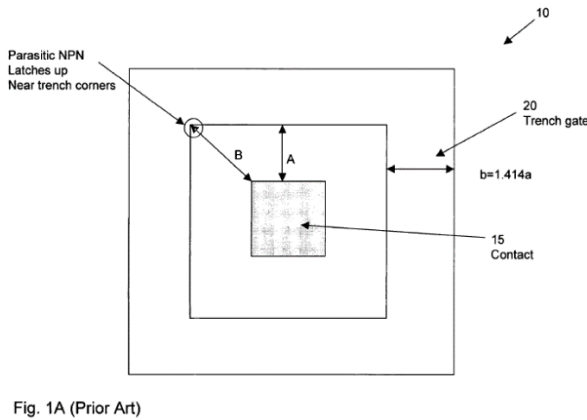

37. The '409 Patent describes and claims a specific way to improve the MOSFET device and manufacture process by configuring the device with the surrounding gate arranged with truncated or rounded corners.

38. Claim 1 of the '409 Patent reads:

1. A trenched semiconductor power device comprising a plurality of trenched gates surrounding a plurality of transistor cells formed in a semiconductor substrate, wherein:
 - said trenched gates surrounding said transistor cells as closed cells constituting substantially square-shaped cells with rounded corners;
 - each of said closed cells further includes a circular trench contact disposed substantially in a central portion of said closed cells, penetrating through a source region surrounding said trenched gates and extending into a body region encompassing said source region;
 - said circular trench contact comprises a hole opened from a top surface of said semiconductor substrate and is filled with a contact metal plug wherein sidewalls of said hole are surrounded by and in contact said source and body regions and said circular trench contact is separate from said trenched gates with said source region and body region disposed between a gate oxide lining of said trenched gates and all circumferential points of the circular trench contact; and;
 - said contact metal plug connected to a source metal disposed on top of said circular trench contact.

ASUS

39. ASUS is a multinational computer hardware and consumer electronics company founded in 1989.

40. According to ASUS, it is the world's number one motherboard and gaming brand and a top-three consumer notebook vendor. [https://www.asus.com/us/About_ASUS/Company-Introduction/#:~:text=](https://www.asus.com/us/About_ASUS/Company-Introduction/#:~:text=ASUS%20is%20a%20Taiwan%2Dbased,top%2Dthree%20consumer%20notebook%20vendor.)

[ASUS%20is%20a%20Taiwan%2Dbased,top%2Dthree%20consumer%20notebook%20vendor.](https://www.asus.com/us/About_ASUS/Company-Introduction/#:~:text=ASUS%20is%20a%20Taiwan%2Dbased,top%2Dthree%20consumer%20notebook%20vendor.)

41. ASUS has more than 17,000 employees and earned approximately \$19.17 billion in revenue in 2021.

42. ASUS sells laptops, including at least the ASUS E410 that include the components 2N7002KDW and 2N7002K.

43. On September 14, 2022, Force MOS, through its counsel, sent ASUS a Notice Letter notifying ASUS that the components 2N7002KDW and 2N7002K contained in the ASUS E410M practice certain claims of the '634 Patent. Included in the Notice Letter was a copy of the '634 Patent as well as a detailed claim chart illustrating how the 2N7002K practices Claim 1 of the '634 Patent.

44. The next month on October 21, 2022, after having received no response from ASUS, Force MOS, again through counsel, sent ASUS a follow up letter.

45. On October 25, 2022, counsel for Force MOS received an email from Michelle Hsu of ASUS informing Force MOS that it should correspond with ASUS's supplier Panjit International Inc. ("Panjit") regarding this matter.

46. On October 28, 2022, counsel for Force MOS informed Ms. Hsu that, given the '634 Patent is a patent issued in the United States, and ASUS sells products containing the

infringing components in the United States, that Force MOS wished to discuss the matter with ASUS directly rather than through a foreign supplier. ASUS responded later that day that it could not engage in such discussions directly with Force MOS because of an indemnification agreement with Panjit and further copied Ingrid Lin from Panjit's Legal Office to carry on the discussion.

47. Ms. Lin's response to Force MOS's attempt to amicably resolve ASUS's infringement of Force MOS's patents was that Force MOS's attempts were "obviously unfair competitions and are illegal in any territory, we have filed related law suits and reported to authority." In addition it was suggested to Force MOS by Ms. Lin that it run its "business with dignity, and please do not keep bothering PANJIT's customers again."

48. Force MOS recently has been notified that the Taiwanese Fair Trade Commission received a report from Panjit complaining of violations of the Taiwanese Fair Trade Act.

COUNT I

(DIRECT PATENT INFRINGEMENT OF THE '634 PATENT)

49. Force MOS repeats, realleges, and incorporates by reference, as if fully set forth herein, the allegations of the preceding paragraphs, as set forth above.

50. ASUS makes, uses, offers to sell, and sells in the United States products, including the ASUS E410M laptop which employs the 2N7002k (the "Accused Products").



2N7002K

MECHANICAL DATA

- Case: SOT-23 Package
- Terminals: Solderable per MIL-STD-750, Method 2026
- Marking: K72
- Approx. Weight: 0.0003 ounce, 0.0084 gram

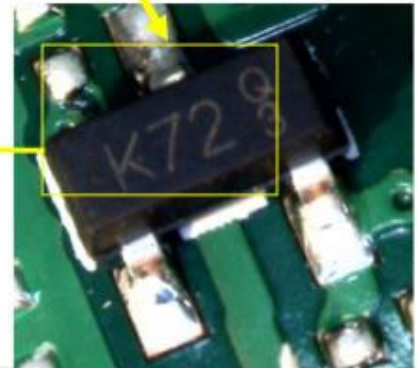
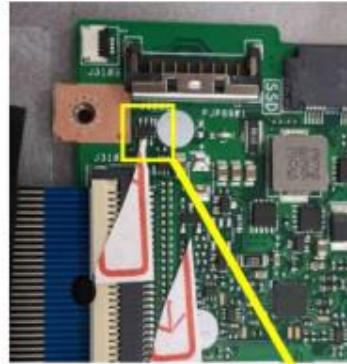
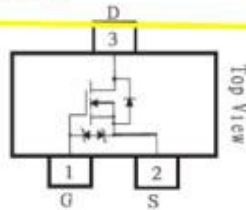

51. The Accused Products have a substrate with an epitaxial layer disposed on the top of the substrate. The trench source contacts are disposed in source layer on top of the base layer which in on top of the epitaxial layer.

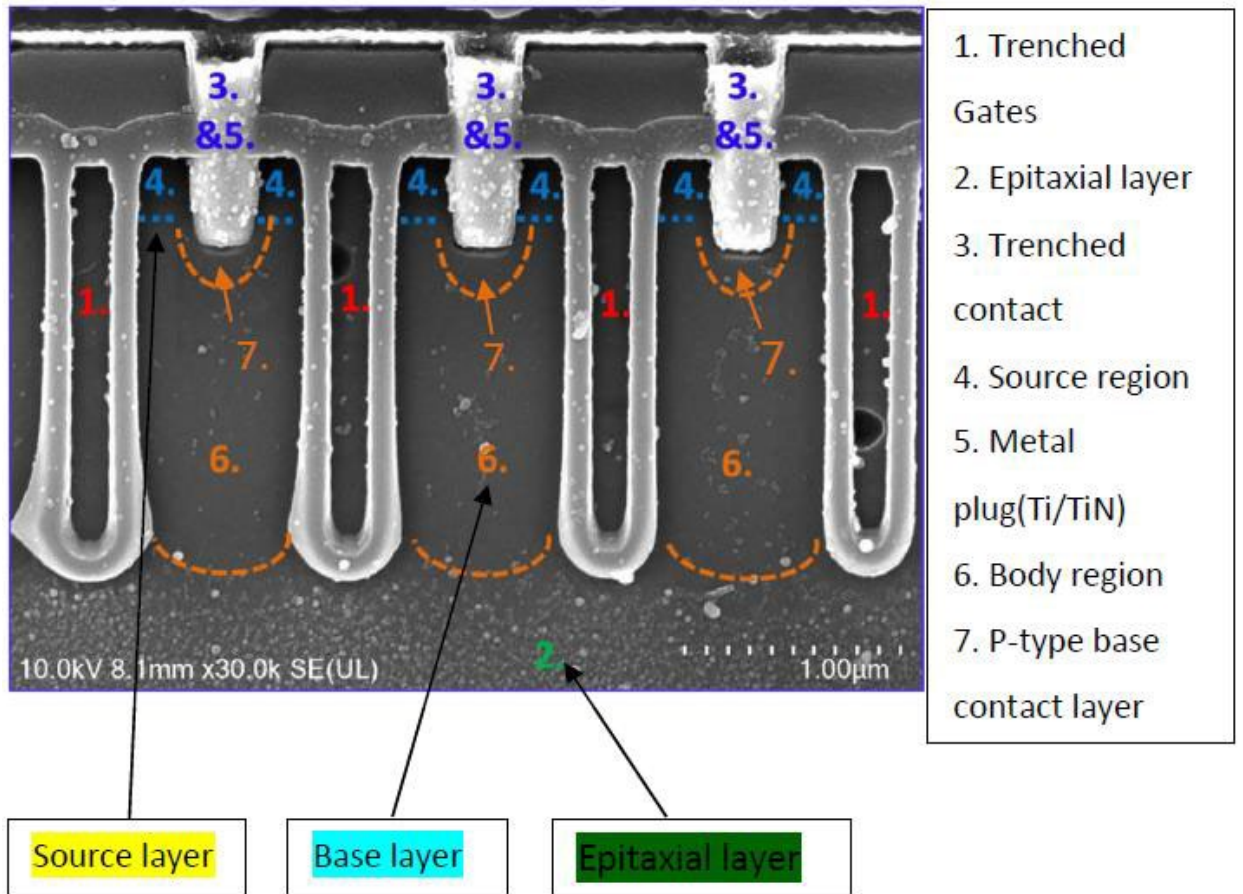

52. The Accused Products have a front metal layer on the upper surface and a bottom metal layer on the lower surface of the substrate.

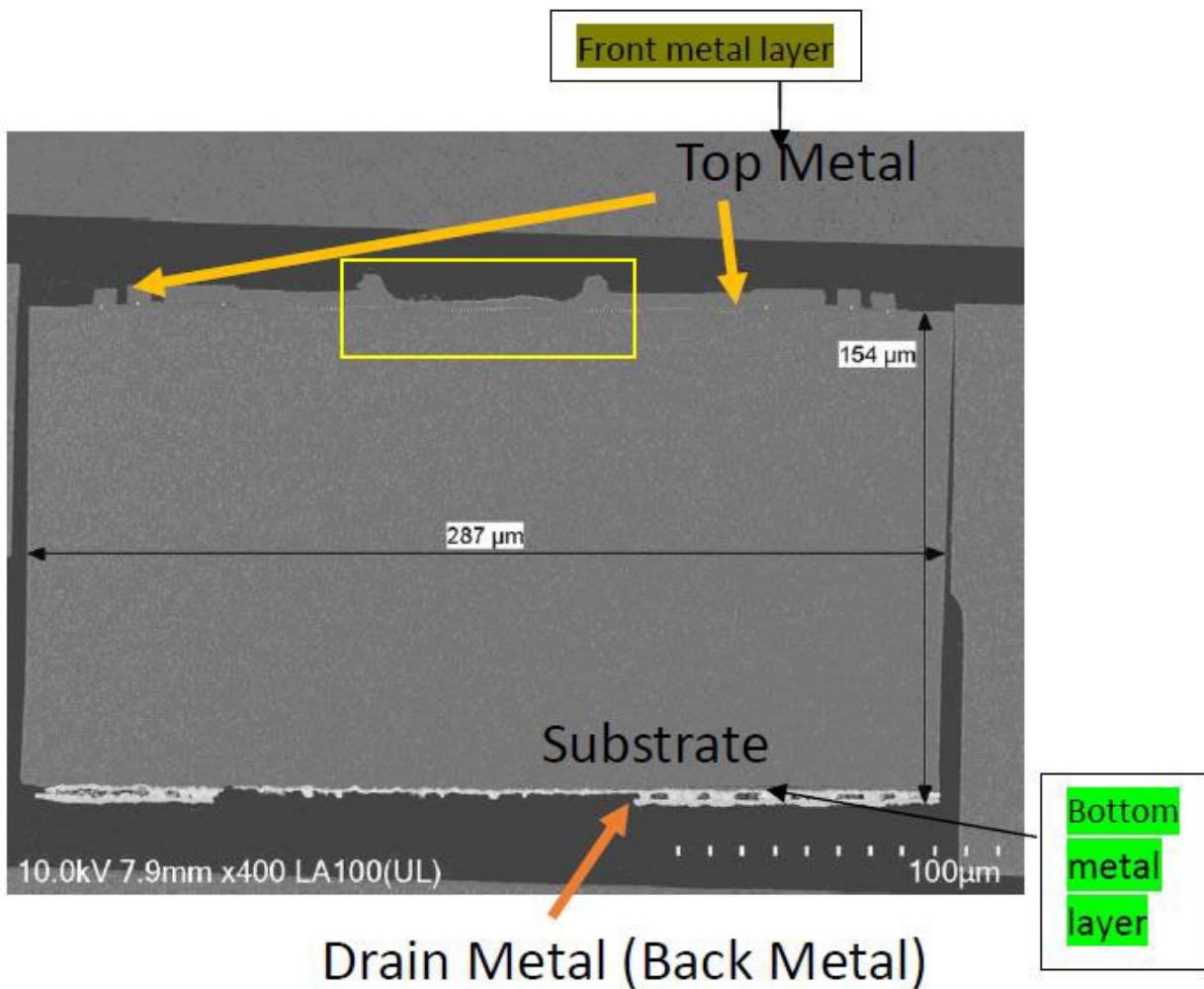

53. The Accused Products have multiple trenched gates covered by interlayer oxide film formed on top of the source layer and multiple source contact trenches formed on top of an interlayer oxide film.

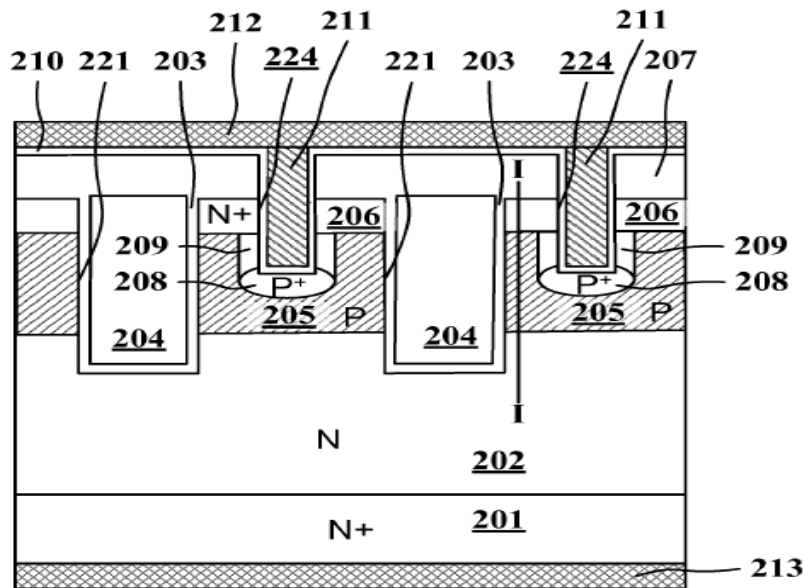
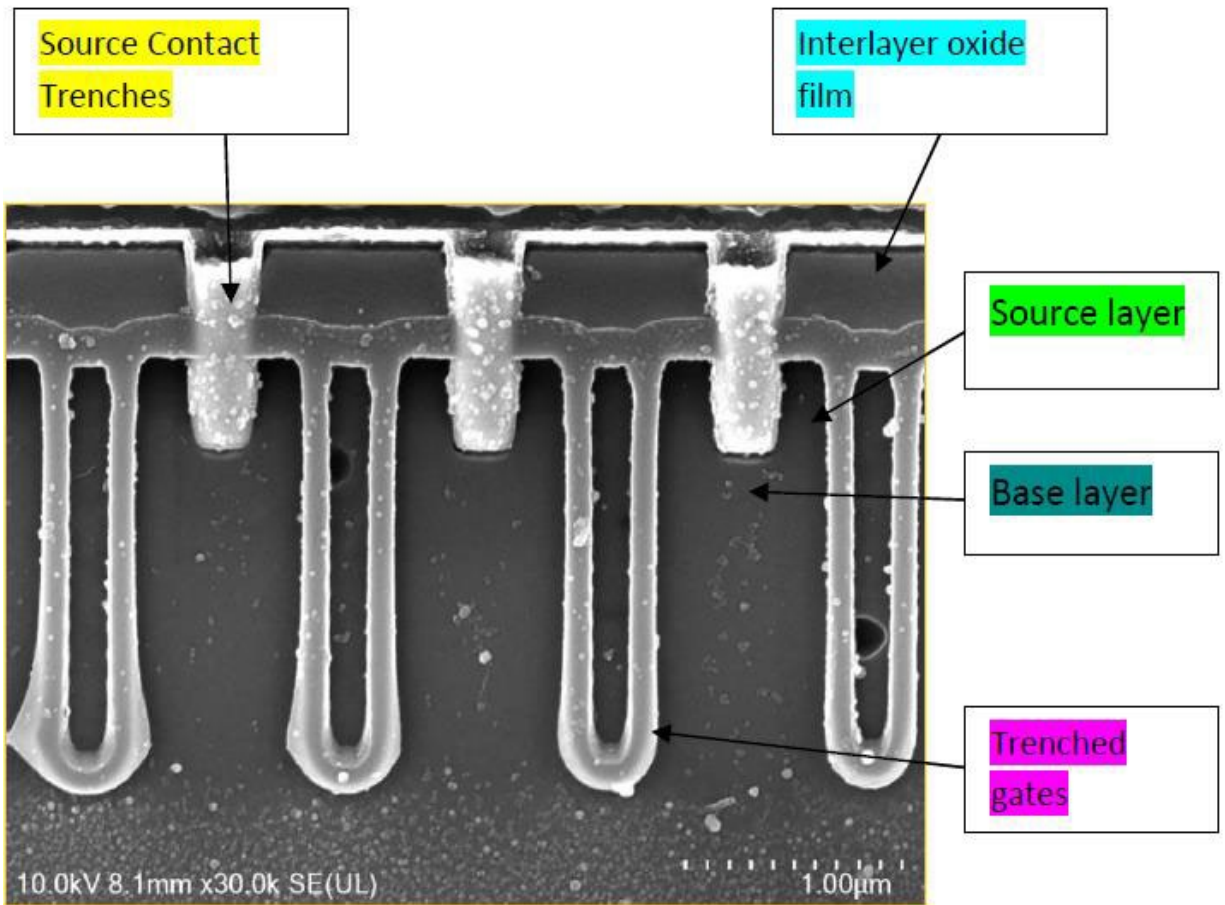

Fig. 2G

57. The Accused Products satisfy each and every element of each asserted claim of the '634 Patent either literally or under the doctrine of equivalents.

58. ASUS's infringing activities are and have been without authority or license under the '634 Patent.

59. As set forth in paragraphs 34-39, ASUS has willfully infringed the '634 Patent. ASUS has had knowledge of Force MOS's patent rights since at least October 28, 2022 and, despite knowledge of Force MOS's patent rights, engaged in egregious behavior warranting enhanced damages.

60. Force MOS is informed and believes that despite ASUS's knowledge of the '634 Patent and Force MOS's patented technology, ASUS made the deliberate decision(s) to make, use, sell, or offer to sell products that it knew infringed Force MOS's '634 Patent.

61. Force MOS is informed and believes that ASUS knew or was willfully blind to Force MOS's technology and the '634 Patent. Despite this knowledge and/or willful blindness, ASUS has acted with blatant and egregious disregard for Force MOS's patent rights with an objectively high likelihood of infringement.

62. Force MOS is informed and believes that ASUS has undertaken no efforts to avoid infringement of the '634 Patent, despite ASUS's knowledge and understanding that ASUS's products infringe the '634 Patent. Indeed, ASUS has been complicit in a Taiwanese Fair Trade Act claim being made against Force MOS for simply asserting Force MOS's patent rights. Thus, ASUS's infringement of '634 Patent is willful and egregious, warranting enhancement of damages.

63. As such, ASUS has acted and continues to act recklessly, willfully, wantonly, deliberately, and egregiously engage in acts of infringement of the '634 Patent, justifying an award

to Force MOS of increased damages under 35 U.S.C. § 284, and attorneys' fees and costs incurred under 35 U.S.C. § 285.

COUNT II

(INDUCED PATENT INFRINGEMENT OF THE '634 PATENT)

64. Force MOS repeats, realleges, and incorporates by reference, as if fully set forth herein, the allegations of the preceding paragraphs, as set forth above.

65. ASUS is liable for indirect infringement under 35 U.S.C. § 271(b) of at least one claim of the '634 Patent, at least as early as October 28, 2022, because it knowingly encourages, aids, and directs others to make, use, sell, or offer for sale the Accused Products.

66. As detailed in paragraphs 34-39, ASUS was informed by Force MOS of the '634 Patent and ASUS's infringement of the '634 Patent in October of 2022.

67. ASUS specifically intends the Accused Products to be used and operated to infringe one or more claims of the '634 Patent.

68. ASUS encourages, directs, aids, and abets the use, configuration, and installation of the Accused Products.

69. ASUS's analysis and knowledge of the '634 Patent combined with its ongoing activity demonstrates ASUS's knowledge and intent that the identified features of its Accused Products be used to infringe the '634 Patent.

70. ASUS's knowledge of the '634 Patent and ASUS's infringement allegations against ASUS combined with its knowledge of the Accused Products and how they are used to infringe the '634 Patent, consistent with ASUS's promotions and instructions, demonstrate ASUS's specific intent to induce infringement the '634 Patent.

71. As set forth in paragraphs 34-39, ASUS knew or was willfully blind to the fact that it was inducing others, including customers, purchasers, users or developers, to infringe by practicing, either themselves or in conjunction with ASUS, one or more claims of the '634 Patent.

72. Force MOS is entitled to recover from ASUS compensation in the form of monetary damages suffered as a result of ASUS's infringement in an amount that cannot be less than a reasonable royalty together with interest and costs as fixed by this Court.

COUNT III

(DIRECT INFRINGEMENT OF THE '346 PATENT)

73. Force MOS repeats, realleges, and incorporates by reference, as if fully set forth herein, the allegations of the preceding paragraphs, as set forth above.

74. ASUS makes, uses, offers to sell, and sells in the United States products, including the ASUS E410M laptop which employs the 2N7002k (the "Accused Products").



2N7002K

MECHANICAL DATA

- Case: SOT-23 Package
- Terminals: Solderable per MIL-STD-750, Method 2026
- Marking: K72
- Approx. Weight: 0.0003 ounce, 0.0084 gram

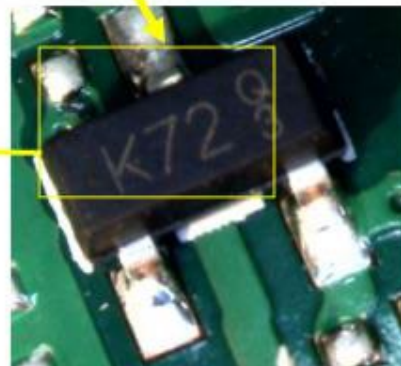
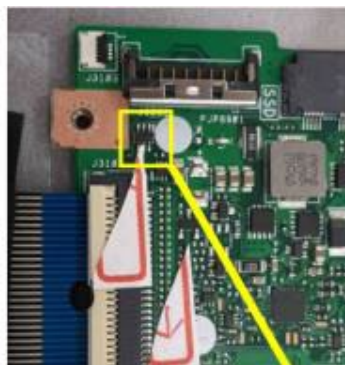
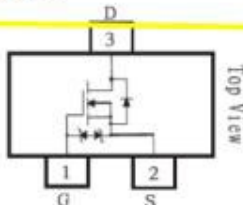

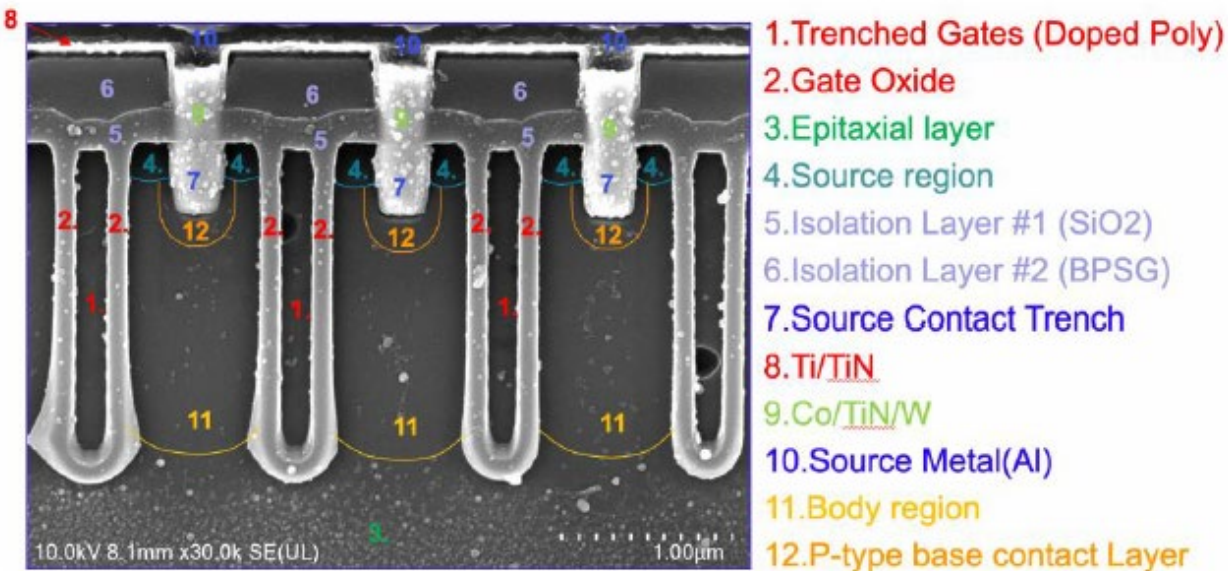

76. The Accused Products use a substrate with an epitaxial layer. The trench source contact is disposed in a source layer on top of the base layer which is on top of an epitaxial layer.

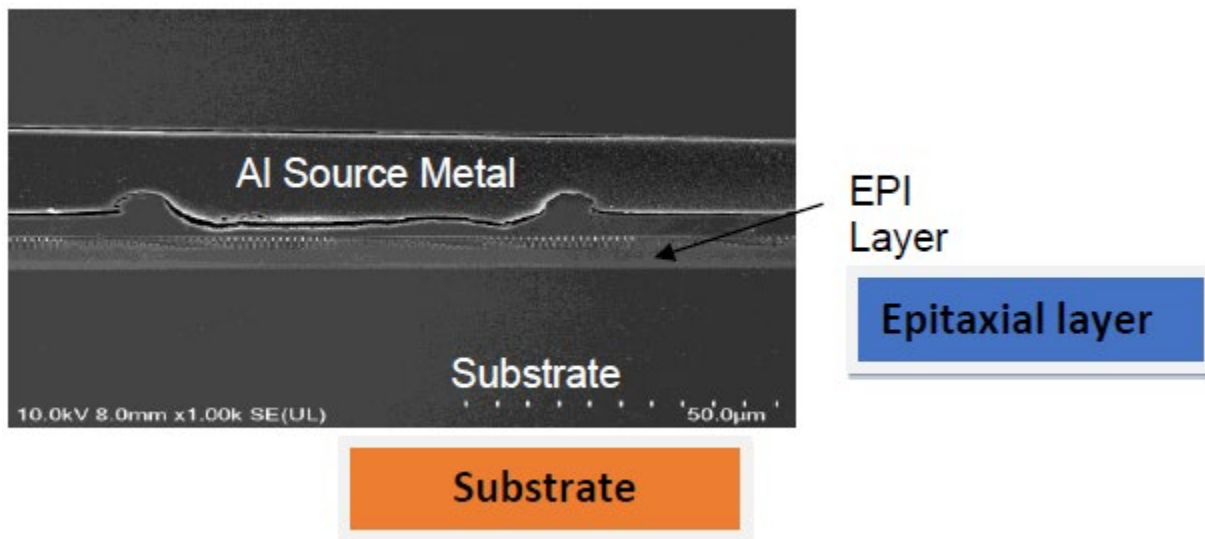

77. The Accused Products have front and back metals with copper wire bonding to the front metal.

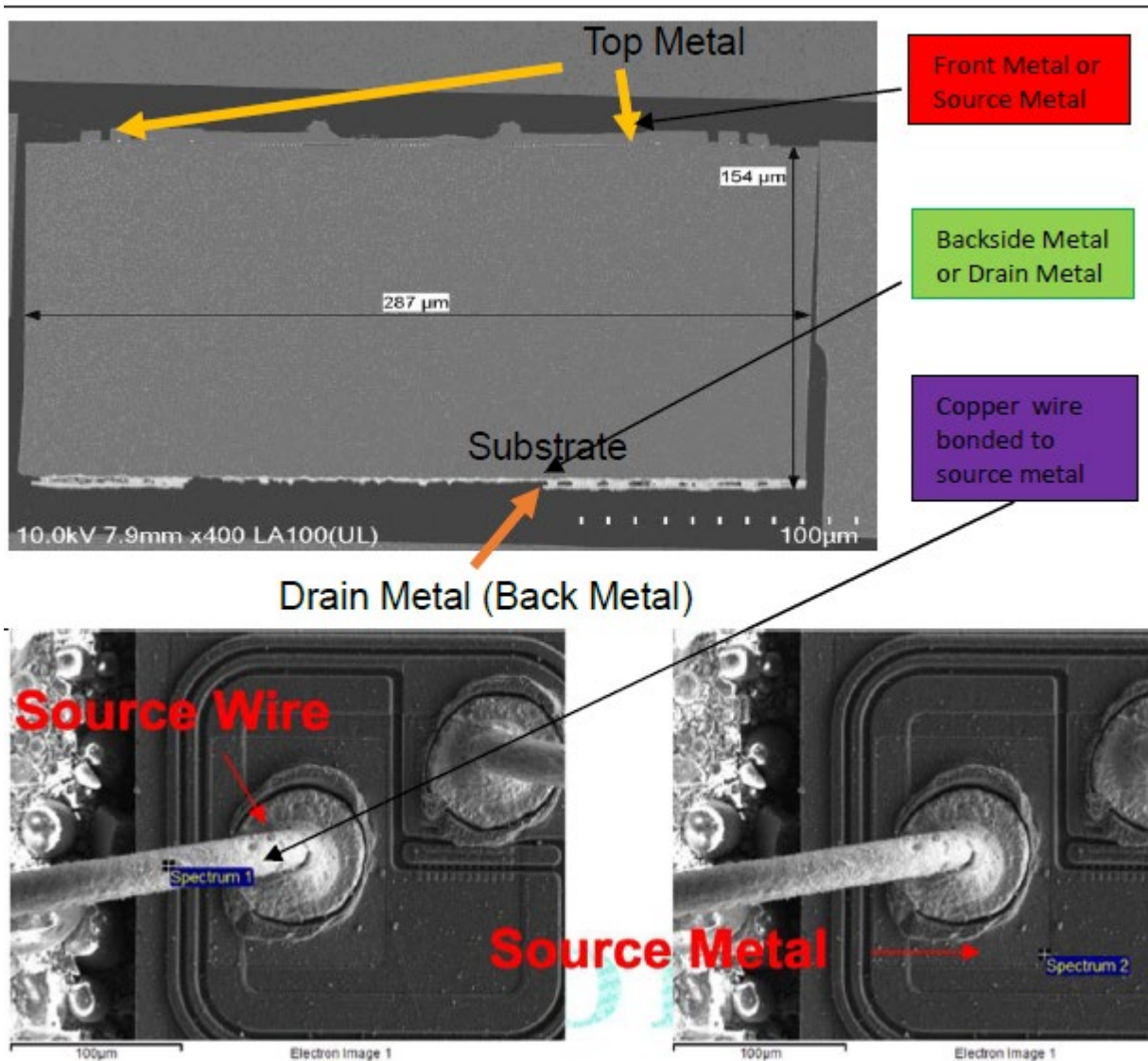

Drain Metal (Back Metal)

78. ASUS has directly infringed the '346 Patent in violation of 35 U.S.C. § 271(a) by making, using, offering for sale, and selling the Accused Products that embody the patented inventions of at least claim 1 of the '346 Patent.

79. ASUS's infringing products include at least products that utilize the 2N7002KDW and 2N7002K components and other products with the same or similar components that satisfy each element of one or more asserted claims.

80. The Accused Products satisfy each and every element of each asserted claim of the '346 Patent either literally or under the doctrine of equivalents.

81. ASUS's infringing activities are and have been without authority or license under the '346 Patent.

82. As set forth in paragraphs 34-39, ASUS has willfully infringed the '346 Patent. ASUS has had knowledge of Force MOS's patent rights in the '634 Patent since at least October 28, 2022, and knowledge of the '346 Patent at least since the filing of this Complaint, and, despite knowledge of Force MOS's patent rights, engaged in egregious behavior warranting enhanced damages.

83. Force MOS is informed and believes that despite ASUS's knowledge of the '346 Patent and Force MOS's patented technology, ASUS made the deliberate decision(s) to make, use, sell, or offer to sell products that it knew infringed Force MOS's '346 Patent.

84. Force MOS is informed and believes that ASUS knew or was willfully blind to Force MOS's technology and the '346 Patent. Despite this knowledge and/or willful blindness, ASUS has acted with blatant and egregious disregard for Force MOS's patent rights with an objectively high likelihood of infringement.

85. Force MOS is informed and believes that ASUS has undertaken no efforts to avoid infringement of the '346 Patent, despite ASUS's knowledge and understanding that ASUS's products infringe the '346 Patent. Indeed, ASUS has been complicit in a Taiwanese Fair Trade Act claim being made against Force MOS for simply asserting Force MOS's patent rights. Thus, ASUS's infringement of '346 Patent is willful and egregious, warranting enhancement of damages.

86. As such, ASUS has acted and continues to act recklessly, willfully, wantonly, deliberately, and egregiously engage in acts of infringement of the '346 Patent, justifying an award

to Force MOS of increased damages under 35 U.S.C. § 284, and attorneys' fees and costs incurred under 35 U.S.C. § 285.

COUNT IV

(INDUCED INFRINGEMENT OF THE '346 PATENT)

87. Force MOS repeats, realleges, and incorporates by reference, as if fully set forth herein, the allegations of the preceding paragraphs, as set forth above.

88. ASUS is liable for indirect infringement under 35 U.S.C. § 271(b) of at least one claim of the '346 Patent, at least as early as the filing date of this Complaint, because it knowingly encourages, aids, and directs others to make, use, sell, or offer for sale the Accused Products.

89. As detailed in paragraphs 34-39, ASUS was informed by Force MOS of the '634 Patent and ASUS's infringement of the '634 Patent in October of 2022.

90. ASUS specifically intends the Accused Products to be used and operated to infringe one or more claims of the '346 Patent.

91. ASUS encourages, directs, aids, and abets the use, configuration, and installation of the Accused Products.

92. ASUS's analysis and knowledge of the '346 Patent combined with its ongoing activity demonstrates ASUS's knowledge and intent that the identified features of its Accused Products be used to infringe the '346 Patent.

93. ASUS's knowledge of the '346 Patent and ASUS's infringement allegations against ASUS combined with its knowledge of the Accused Products and how they are used to infringe the '346 Patent, consistent with ASUS's promotions and instructions, demonstrate ASUS's specific intent to induce infringement the '346 Patent.

94. ASUS knew or was willfully blind to the fact that it was inducing others, including customers, purchasers, users or developers, to infringe by practicing, either themselves or in conjunction with ASUS, one or more claims of the '346 Patent.

95. Force MOS is entitled to recover from ASUS compensation in the form of monetary damages suffered as a result of ASUS's infringement in an amount that cannot be less than a reasonable royalty together with interest and costs as fixed by this Court.

COUNT V

(DIRECT INFRINGEMENT OF THE '409 PATENT)

96. Force MOS repeats, realleges, and incorporates by reference, as if fully set forth herein, the allegations of the preceding paragraphs, as set forth above.

97. Asus makes, uses, offers to sell, and sells in the United States, since at least as early as June of 2018, laptops, such as the ASUSPRO P5430U, which employ the PJX138 and 2N7002K chips (the "Accused Products").



2N7002K

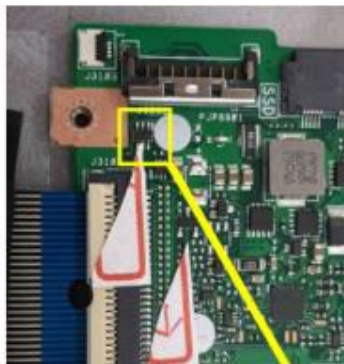

MECHANICAL DATA

- Case: SOT-23 Package
- Terminals: Solderable per MIL-STD-750, Method 2026
- Marking: K72
- Approx. Weight: 0.0003 ounce, 0.0084 gram

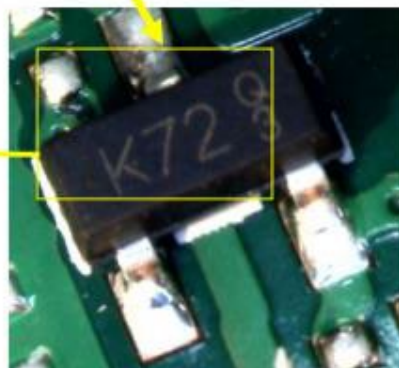
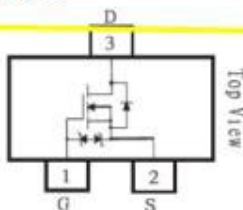

98. The Accused Products employ the same layout as the '409 Patent.

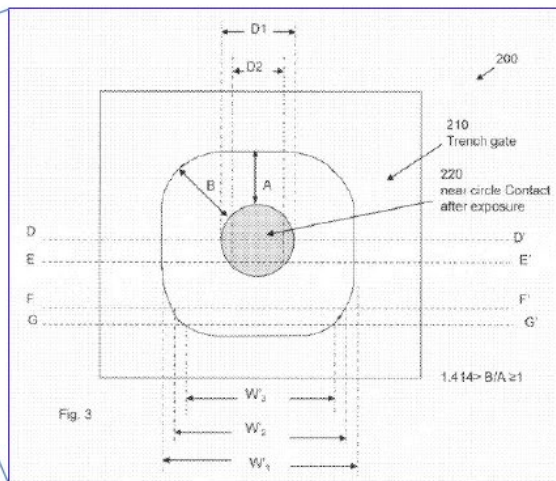
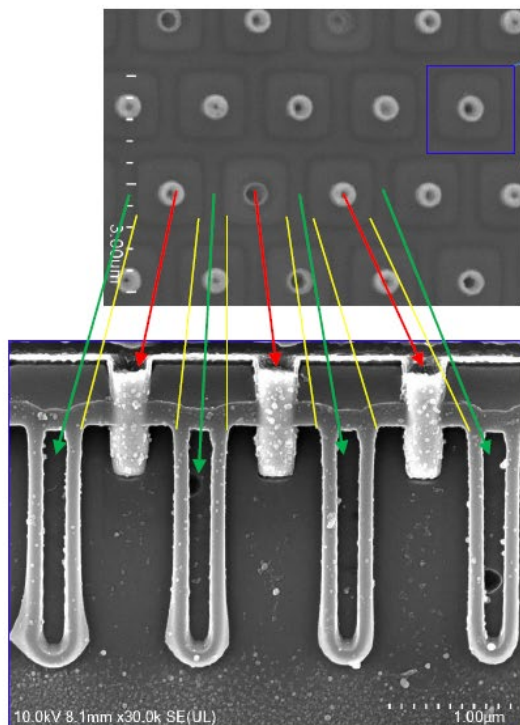

99. The Accused Products are formed in a semiconductor substrate wherein trenched gates surrounding the transistor cells as closed cells constituting substantially square-shaped celled with rounded corners.

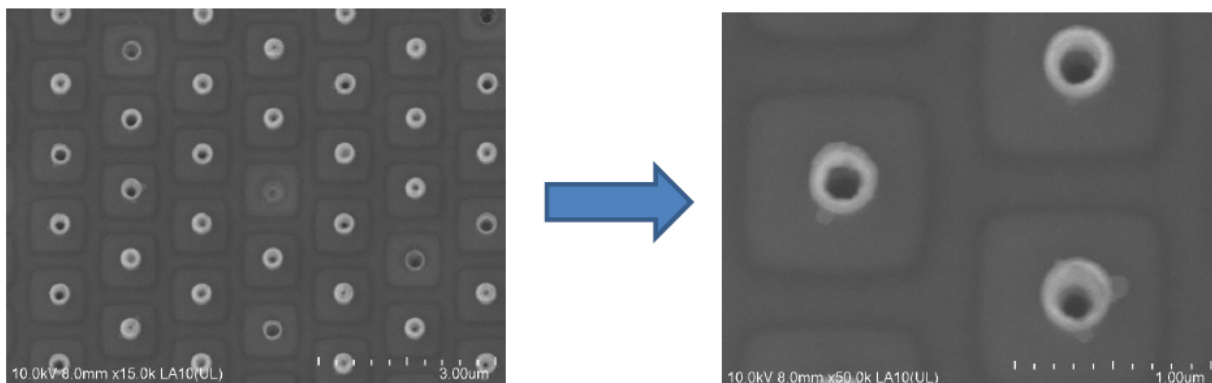

100. The Accused Products have closed cells which further include circular trench contacts in a central portion penetrating through a source region surrounding the trenched gates.

101. The Accused Products have a circular trench contact comprised of a hole opened from the top surface of the semiconductor substrate and filled with a contact metal plug.

102. The Accused Products have a body region disposed between a gate oxide lining of the trenched gates and all circumferential points of the circular trench contact.

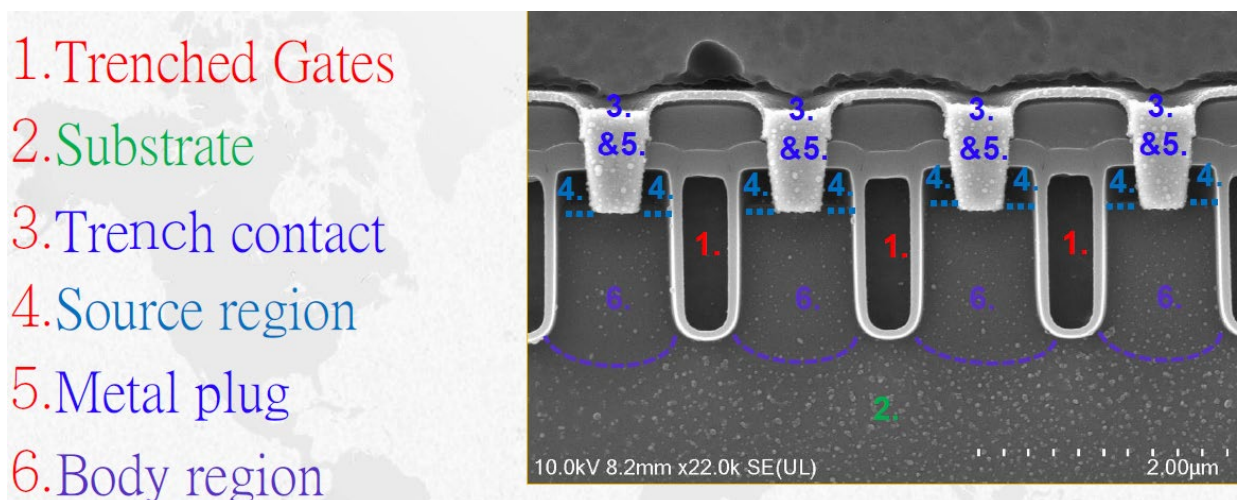

103. ASUS has directly infringed the '409 Patent in violation of 35 U.S.C. § 271(a) by making, using, offering for sale, and selling the Accused Products that embody the patented inventions of at least claim 1 of the '409 Patent.

104. ASUS's infringing products include at least products that utilize the PJX138 and 2N7002K components and other products with the same or similar components that satisfy each element of one or more asserted claims.

105. The Accused Products satisfy each and every element of each asserted claim of the '409 Patent either literally or under the doctrine of equivalents.

106. ASUS's infringing activities were without authority or license under the '409 Patent.

JURY DEMAND

Force MOS hereby demands a trial by jury of all issues so triable pursuant to Rule 38 of the Federal Rules of Civil Procedure.

PRAYER FOR RELIEF

WHEREFORE, Force MOS prays for relieve against ASUS as follows:

- (A) An entry of judgment that ASUS has infringed and is directly infringing one or more claims of each of the Patents-in-Suit;
- (B) An entry of judgment that ASUS has infringed and is indirectly infringing one or more claims of each of the Patents-in-Suit;
- (C) An order pursuant to 35 U.S.C. § 283 permanently enjoining ASUS, its officers, agents, servants, employees, attorneys, and those persons in active concert or participation with it, from further acts of infringement of the Patents-in-Suit;
- (D) An entry of judgment that the Patents-in-Suit are valid and enforceable;

- (E) An order awarding damages sufficient to compensate Force MOS for ASUS's infringement of the Patents-in-Suit, but in no event less than a reasonable royalty, together with interest and costs;;
- (F) A determination that ASUS's infringement has been willful, wanton, deliberate, and egregious;
- (G) A determination that the damages against ASUS be trebled or for any other basis within the Court's discretion pursuant to 35 U.S.C. § 284;
- (H) A finding that this case against ASUS is "exceptional" and an award to Force MOS of its costs and reasonable attorneys' fees, as provided by 35 U.S.C. § 285;
- (I) An accounting of all infringing sales and revenues of ASUS, together with post judgment interest and prejudgment interest from the first date of infringement of the '634 Patent, the '346 Patent, and the '409 Patent; and
- (J) Such further and other relief as the Court may deem proper and just.

Dated: March 7, 2023

Respectfully submitted,

/s/ Joshua G. Jones

Christopher E. Hanba

Texas Bar No. 24121391

chanba@dickinson-wright.com

Joshua G. Jones

Texas Bar No. 24065517

jjones@dickinson-wright.com

DICKINSON WRIGHT PLLC

607 W. 3rd Street, Suite 2500

Austin, Texas 78701

Telephone: (512) 582-6889

Facsimile: (844) 670-6009

Attorneys for Plaintiff

Force MOS Technology Co., Ltd.

CERTIFICATE OF SERVICE

I certify that on March 7, 2023, Plaintiff's FIRST AMENDED COMPLAINT was filed via the Court's CM/ECF system which will send notification of such filing to all counsel of record.

/s/ Joshua G. Jones
Joshua G. Jones