

IN THE UNITED STATES PATENT AND TRADEMARK OFFICE

In re Patent of: Xiaobo Zhang
U.S. Patent No.: 10,462,767 Attorney Docket No. 50095-0225IP1
Issue Date: October 29, 2019
Appl. Serial No.: 15/956,742
Filing Date: April 18, 2018
Title: METHOD AND DEVICE IN UE AND BASE STATION USED
FOR PAGING

Mail Stop Patent Board

Patent Trial and Appeal Board
U.S. Patent and Trademark Office
P.O. Box 1450
Alexandria, VA 22313-1450

**PETITION FOR *INTER PARTES* REVIEW OF UNITED STATES PATENT
NO. 10,462,767 PURSUANT TO 35 U.S.C. §§ 311–319, 37 C.F.R. § 42**

TABLE OF CONTENTS

I.	REQUIREMENTS	1
	A. Grounds for Standing.....	1
	B. Challenge Under 37 C.F.R. § 42.104(b) and Relief Requested	1
II.	TECHNOLOGY BACKGROUND	4
	A. 3rd Generation Partnership Project (3GPP).....	4
	B. Features of 4G/LTE and Older Networks.....	4
	1. Resource Grid and Frame Structure	4
	2. Subcarrier Spacing	6
	3. Paging	7
	4. Monitoring of Physical Downlink Control Channel (PDCCH)	8
	5. Coverage Enhancement (CE)	11
	C. 5G/NR Networks	12
	1. Configurable Numerology.....	12
	2. Various Frame Structures.....	13
III.	THE '767 PATENT	14
	A. Summary	14
	B. Brief Prosecution History	17
	C. Claim Construction	18
IV.	LEVEL OF ORDINARY SKILL IN THE ART	20
V.	THE CHALLENGED CLAIMS ARE UNPATENTABLE	21
	A. [GROUND 1] <i>Yeo</i> and <i>TS36</i> render obvious claims 1, 4-6, 9-11, 14-16, 19, and 20.....	21
	1. Independent Claim 1.....	32
	2. Claim 4	46
	3. Claim 5	48
	4. Claim 6	51
	5. Claim 9	54
	6. Claim 10	54
	7. Claims 11, 14, and 15.....	54
	8. Claims 16, 19, and 20.....	59
	B. [GROUND 2] Claims 2, 3, 7, 8, 12, 13, 17, and 18 Are Obvious over <i>Yeo</i> , <i>TS36</i> , and <i>Mallick</i>	63
	1. Claim 2	69
	2. Claim 3	76
	3. Claims 7 and 8.....	80

4.	Claims 12 and 13	80
5.	Claims 17 and 18	81
VI.	DISCRETIONARY DENIAL IS NOT WARRANTED.....	81
VII.	PAYMENT OF FEES – 37 C.F.R. § 42.103	81
VIII.	CONCLUSION.....	81
IX.	MANDATORY NOTICES UNDER 37 C.F.R. § 42.8(a)(1).....	83
	A. Real Party-In-Interest Under 37 C.F.R. § 42.8(b)(1).....	83
	B. Related Matters Under 37 C.F.R. § 42.8(b)(2)	83
	C. Lead And Back-Up Counsel Under 37 C.F.R. § 42.8(b)(3).....	84
	D. Service Information	84

LIST OF EXHIBITS

APPLE-1001	U.S. Patent No. 10,462,767
APPLE-1002	U.S. Patent No. 10,462,767 File History
APPLE-1003	Declaration of Dr. Zhi Ding
APPLE-1004	International Patent Publication No. WO 2018/126401 to Liu et al., filed January 5, 2017, and published July 12, 2018 (“ <i>Liu</i> ”)
APPLE-1005	U.S. Patent 10,491,447 to Yeo et al., filed August 22, 2017, and claiming priority to KR applications 10-2016-0106427 (filed August 22, 2016) and 10-2016-0125809 (filed September 29, 2016) (“ <i>Yeo</i> ”)
APPLE-1006	Certified translated copy of KR Application 10-2016-0125809 (filed September 29, 2016) (“ <i>Yeo-Priority</i> ”)
APPLE-1007	International Patent Publication No. WO 2017/052199 to You et al., filed September 21, 2016, and published March 30, 2017 (“ <i>You</i> ”)
APPLE-1008	International Patent Publication No. WO 2016/136143 to Mallick et al., filed January 28, 2016, and published September 1, 2016 (“ <i>Mallick</i> ”)
APPLE-1009	3GPP TS 36.304 V14.2.0, Technical Specification Group Radio Access Network; Evolved Universal Terrestrial Radio Access (E-UTRA); User Equipment (UE) procedures in idle mode (Release 14), March 2017, (“ <i>TS36</i> ”).
APPLE-1010	U.S. Patent Publication No. 2012/0122495 to Weng et al., filed November 11, 2010, and published May 17, 2012 (“ <i>Weng</i> ”)

- APPLE-1011 International Patent Publication No. WO 2017/174469 to Wong et al., filed March 31, 2017, and published October 12, 2017 (“*Wong*”)
- APPLE-1012 International Patent Publication No. WO 2017/026983 to Khoryaev et al., filed December 26, 2015, and published February 16, 2017 (“*Khoryaev*”)
- APPLE-1013 International Patent Publication No. WO 2015/113664 to Webb et al., filed November 13, 2014, and published August 6, 2015 (“*Webb*”)
- APPLE-1014 RESERVED
- APPLE-1015 International Patent Publication No. WO 2016/130175 to Fwu et al., filed August 11, 2015, and published August 18, 2016 (“*Fwu*”)
- APPLE-1016 U.S. Patent Publication No. 2017/0215170 to Islam et al., filed January 26, 2016, and published July 27, 2017 (“*Islam*”).
- APPLE-1017 International Patent Publication No. WO 2017/079530 to Pelletier, filed November 4, 2016, and published May 11, 2017 (“*Pelletier*”).
- APPLE-1018 International Patent Publication No. WO 2017/171398 to Yi et al., filed March 29, 2017, and published October 5, 2017 (“*Yi*”)
- APPLE-1019 U.S. Patent No. 9,225,440 to Swarts et al., filed September 14, 2012, and issued December 29, 2015 (“*Swarts*”).
- APPLE-1020 U.S. Patent Publication No. 2015/0215944 to Kim et al., filed January 29, 2015, and published July 30, 2015 (“*Kim*”).

- APPLE-1021 U.S. Patent Publication No. 2011/0038330 to Luo et al., filed July 29, 2010, and published February 17, 2011 (“*Luo*”).
- APPLE-1022 Declaration of Friedhelm Rodermund
- APPLE-1023 First Amended Complaint – filed May 2, 2024; *Apex Beam Technologies LLC, v. Apple Inc.*, Case No. 6:24-cv-00223-ADA-DIG, W.D. Tex.
- APPLE-1024 R1-165162, *On Numerology for New Radio Access Technology*, 3GPP TSG RAN WG1 Meeting #85, Nanjing, China, 23th – 27th May 2016.
- APPLE-1025 3GPP TS 36.306 V14.1.0, Technical Specification Group Radio Access Network; Evolved Universal Terrestrial Radio Access (E-UTRA); User Equipment (UE) radio access capabilities (Release 14), December 2016.
- APPLE-1026 A. Roessler, J. Schlien, S. Merkel, M. Kottkamp, “*LTE-Advanced (3GPP Rel.12) Technology Introduction White Paper*”
- APPLE-1027 Original Complaint, *Apex Beam Technologies LLC, v. Apple Inc.*, Case No. 6:24-cv-00223, W.D. Tex., filed April 29, 2024.
- APPLE-1028 Proof of Service of Complaint, *Apex Beam Technologies LLC v. Apple Inc.*, 6:24-cv-00223, W.D. Tex.

LISTING OF CLAIMS

Claim 1	
[1pre]	A method in a User Equipment (UE) for paging, comprising:
[1a]	monitoring a first signaling in X time intervals; and
[1b]	receiving a first radio signal;
[1c]	wherein X is a positive integer;
[1d]	the first signaling is used for determining scheduling information for the first radio signal;
[1e]	the scheduling information comprises at least one of {occupied time-frequency resource, adopted Modulation Coding Scheme (MCS), subcarrier spacing of subcarriers in occupied frequency domain resource};
[1f]	the first radio signal carries a paging message;
[1g]	the frequency domain resource used for transmitting the first signaling belongs to a first subband;
[1h]	the first subband comprises a positive integer number of consecutive subcarriers in frequency domain; and
[1i]	at least one of {location of the first subband in frequency domain, subcarrier spacing of subcarriers included in the first subband} is used for determining the X time intervals.
Claim 2	
[2a]	The method according to claim 1, wherein any one of the X time intervals belongs to a first time window in time domain;
[2b]	the time length of the first time window is predefined;
[2c]	the first time window is divided into Y time intervals;
[2d]	the X time intervals are X time intervals of the Y time intervals, Y being a positive integer not smaller than X;

[2e]	the subcarrier spacing of subcarriers included in the first subband is used for determining Y; and
[2f]	a feature ID of a monitor of the first signaling is used for determining the X time intervals in the Y time intervals.
Claim 3	
[3a]	The method according to claim 2, wherein the first time window belongs to one of Z time windows, Z being an integer greater than 1;
[3b]	Z is predefined, or Z is configurable;
[3c]	any two of the Z time windows have an equal time length; and
[3d]	the feature ID of the monitor of the first signaling is used for determining the first time window in the Z time windows.
Claim 4	
[4a]	The method according to claim 1, further comprising: receiving a second radio signal;
[4b]	wherein the second radio signal is used for determining at least one of {location of the first subband in frequency domain, subcarrier spacing of subcarriers included in the first subband}.
Claim 5	
[5a]	The method according to claim 1, further comprising: receiving a second signaling;
[5b]	wherein the second signaling is used for determining Q subbands, Q being a positive integer;
[5c]	the first subband belongs to one of the Q subbands;
[5d]	any one of the Q subbands comprises a positive integer number of consecutive subcarriers; and
[5e]	the feature ID of the monitor of the first signaling is used for determining the first subband in the Q subbands.

Claim 6	
[6pre]	A method in a base station for paging, comprising:
[6a]	transmitting a first signaling in a positive integer number of time intervals of X time intervals; and
[6b]	transmitting a first radio signal;
Remaining Limitations	wherein X is a positive integer; the first signaling is used for determining scheduling information for the first radio signal; the scheduling information comprises at least one of {occupied time-frequency resource, adopted MCS, subcarrier spacing of subcarriers in occupied frequency domain resource}; the first radio signal carries a paging message; the frequency domain resource used for transmitting the first signaling belongs to a first subband; the first subband comprises a positive integer number of consecutive subcarriers in frequency domain; and at least one of {location of the first subband in frequency domain, subcarrier spacing of subcarriers included in the first subband} is used for determining the X time intervals.
Claim 7	
7.	The method according to claim 6, wherein any one of the X time intervals belongs to a first time window in time domain; the time length of the first time window is predefined; the first time window is divided into Y time intervals; the X time intervals are X time intervals of the Y time intervals, Y being a positive integer not smaller than X; the subcarrier spacing of subcarriers included in the first subband is used for determining Y; and a feature ID of a monitor of the first signaling is used for determining the X time intervals in the Y time intervals.

Claim 8	
8.	The method according to claim 7, wherein the first time window belongs to one of Z time windows, Z being an integer greater than 1; Z is predefined, or Z is configurable; any two of the Z time windows have an equal time length; and the feature ID of the monitor of the first signaling is used for determining the first time window in the Z time windows.
Claim 9	
9.	The method according to claim 6, further comprising: transmitting a second radio signal; wherein the second radio signal is used for determining at least one of {location of the first subband in frequency domain, subcarrier spacing of subcarriers included in the first subband}.
Claim 10	
10.	The method according to claim 6, further comprising: transmitting a second signaling; wherein the second signaling is used for determining Q subbands, Q being a positive integer; the first subband belongs to one of the Q subbands; any one of the Q subbands comprises a positive integer number of consecutive subcarriers; and the feature ID of the monitor of the first signaling is used for determining the first subband in the Q subbands.

Claim 11

11. A UE for paging, comprising:
a first receiver module, to monitor a first signaling in X time intervals; and
a second receiver module, to receive a first radio signal;
wherein X is a positive integer; the first signaling is used for determining scheduling information for the first radio signal; the scheduling information comprises at least one of {occupied time-frequency resource, adopted MCS, subcarrier spacing of subcarriers in occupied frequency domain resource}; the first radio signal carries a paging message; the frequency domain resource used for transmitting the first signaling belongs to a first subband; the first subband comprises a positive integer number of consecutive subcarriers in frequency domain; and at least one of {location of the first subband in frequency domain, subcarrier spacing of subcarriers included in the first subband} is used for determining the X time intervals.

Claim 12

12. The UE according to claim 11, wherein any one of the X time intervals belongs to a first time window in time domain; the time length of the first time window is predefined; the first time window is divided into Y time intervals; the X time intervals are X time intervals of the Y time intervals, Y being a positive integer not smaller than X; the subcarrier spacing of subcarriers included in the first subband is used for determining Y; and a feature ID of a monitor of the first signaling is used for determining the X time intervals in the Y time intervals.

Claim 13	
13.	The UE according to claim 12, wherein the first time window belongs to one of Z time windows, Z being an integer greater than 1; Z is predefined, or Z is configurable; any two of the Z time windows have an equal time length; and the feature ID of the monitor of the first signaling is used for determining the first time window in the Z time windows.
Claim 14	
14.	The UE according to claim 11, wherein the first receiver module further receives a second radio signal; the second radio signal is for determining at least one of {location of the first subband in frequency domain, subcarrier spacing of subcarriers included in the first subband}.
Claim 15	
15.	The UE according to claim 11, wherein the first receiver module further receives a second signaling; the second signaling is for determining Q subbands, Q being a positive integer; the first subband belongs to one of the Q subbands; any one of the Q subbands comprises a positive integer number of consecutive subcarriers; and the feature ID of the monitor of the first signaling is used for determining the first subband in the Q subbands.

Claim 16

16. A base station for paging, comprising:
a first transmitter module, to transmit a first signaling in a positive integer number of time intervals of X time intervals; and
a second transmitter module, to transmit a first radio signal;
wherein X is a positive integer; the first signaling is used for determining scheduling information for the first radio signal; the scheduling information comprises at least one of {occupied time-frequency resource, adopted MCS, subcarrier spacing of subcarriers in occupied frequency domain resource}; the first radio signal carries a paging message; the frequency domain resource used for transmitting the first signaling belongs to a first subband; the first subband comprises a positive integer number of consecutive subcarriers in frequency domain; and at least one of {location of the first subband in frequency domain, subcarrier spacing of subcarriers included in the first subband} is used for determining the X time intervals.

Claim 17

17. The base station according to claim 16, wherein any one of the X time intervals belongs to a first time window in time domain; the time length of the first time window is predefined; the first time window is divided into Y time intervals; the X time intervals are X time intervals of the Y time intervals, Y being a positive integer not smaller than X ; the subcarrier spacing of subcarriers included in the first subband is used for determining Y ; and a feature ID of a monitor of the first signaling is used for determining the X time intervals in the Y time intervals.

Claim 18	
18.	The base station according to claim 17, wherein the first time window belongs to one of Z time windows, Z being an integer greater than 1; Z is predefined, or Z is configurable; any two of the Z time windows have an equal time length; and the feature ID of the monitor of the first signaling is used for determining the first time window in the Z time windows.
Claim 19	
19.	The base station according to claim 16, wherein the first transmitter module further transmits a second radio signal; the second radio signal is for determining at least one of {location of the first subband in frequency domain, subcarrier spacing of subcarriers included in the first subband}.
Claim 20	
20.	The base station according to claim 16, wherein the first transmitter module further transmits a second signaling; the second signaling is for determining Q subbands, Q being a positive integer; the first subband belongs to one of the Q subbands; any one of the Q subbands comprises a positive integer number of consecutive subcarriers; and the feature ID of the monitor of the first signaling is used for determining the first subband in the Q subbands.

Apple Inc. (“Apple” or “Petitioner”) petitions for IPR of claims 1-20 (“Challenged Claims”) of U.S. Patent No. 10,462,767 (“the ’767 patent”).

I. REQUIREMENTS

A. Grounds for Standing

Apple Inc. certifies that the ’767 Patent is available for IPR. The present petition is being filed within one year of service of a complaint against Apple. Apple is not barred or estopped from requesting this review. APPLE-1023; APPLE-1027; APPLE-1028.

B. Challenge Under 37 C.F.R. § 42.104(b) and Relief Requested

Apple requests IPR and invalidation of the Challenged Claims on the grounds below. In support, this petition includes a declaration from Dr. Zhi Ding (“Expert Declaration”), referenced throughout this Petition.

Ground	Claims	Basis
Ground 1	1, 4-6, 9-11, 14-16, 19, and 20	§103: <i>Yeo, TS36</i>
Ground 2	2, 3, 7, 8, 12, 13, 17, and 18	§103: <i>Yeo, TS36, Mallick</i>

The ’767 Patent was filed on 4/18/2018, and claims priority to a CN Application filed 04/19/2017 (“Critical Date”). Apple does not concede that the Challenged Claims are entitled to the claimed priority, but applies prior art before the Critical Date. APPLE-1003, 22. Applied references are prior art on at least the following bases:

Reference	Date(s)	Basis
<i>Yeo</i>	09/29/2016	102(a)(2)
<i>TS36</i>	03/22/2017	102(a)(1)
<i>Mallick</i>	09/01/2016	102(a)(1) and 102(a)(2)

U.S. Patent 10,491,447 (*Yeo*) claims priority to KR Application 10-2016-0125809¹ filed on September 29, 2016 (APPLE-1006-*Yeo-Priority*). This Petition includes citations to *Yeo* (APPLE-1005) and also to the corresponding portions in *Yeo-Priority* (APPLE-1006).

APPLE-1009, *TS36*, is a document that on its face lists March, 2017 as a publication date for the document. Indeed, the document was “published and freely available on 3GPP’s ftp server by March 22, 2017” as a part of standard business practices of 3GPP, which assigns a temporary document number and makes publicly available all draft technical specifications, proposals, reports, and other temporary documents to be discussed or considered in relation to 3GPP’s telecommunications standards activities. APPLE-1022, ¶¶25, 54. This is also confirmed by the date stamp shown on the historic 3GPP ftp server for the

¹ *Yeo* also claims priority to KR applications 10-2016-0106427 (filed August 22, 2016), but is not being relied upon in this IPR.

corresponding downloadable file (“36304-e20.zip”), as shown in the screenshot below:

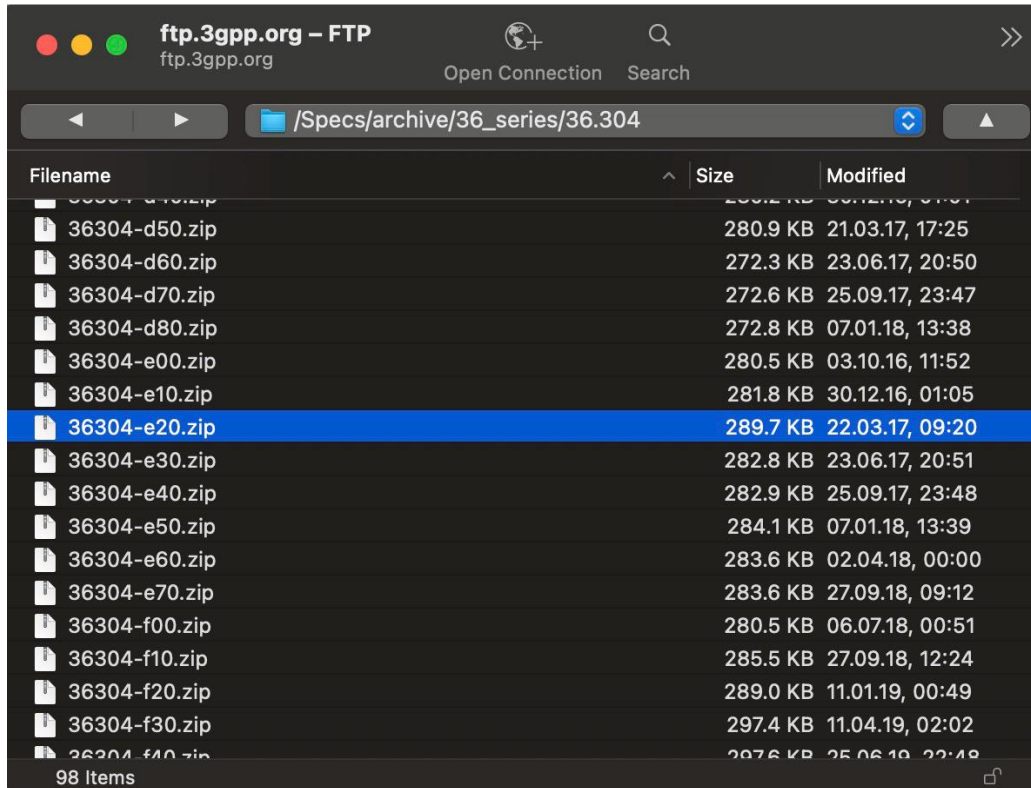

Id., ¶54.

Further, an interested member of the public without prior knowledge of the TS number and even without prior knowledge of 3GPP would have been able to locate *TS36*. *Id.*, ¶59. Because an electronic publication, including an online database is considered to be a “printed publication” within the meaning of 35 U.S.C. 102(a)(1) provided the publication was accessible to persons concerned with the art to which the document relates—*see In re Wyer*, 655 F.2d 221, 227, 210 USPQ 790, 795 (CCPA 1981)—*TS36* qualifies as a printed publication.

APPLE-1008, *Mallick*, was filed on January 28, 2016, and published on September 1, 2016.

II. TECHNOLOGY BACKGROUND

A. 3rd Generation Partnership Project (3GPP)

3GPP is an international partnership of standards-setting organizations (ARIB, ATIS, CCSA, ETSI, TSDSI, TTA, and TTC) for developing interoperable global standards for cellular phone systems, including 3rd generation wireless networks (3G), 4th generation wireless networks/Long Term Evolution (4G/LTE), and 5th generation wireless networks/new radio (5G/NR). 3GPP is a de facto international organization for setting standards that govern cellular networks. The 3GPP's Standards are described in 3GPP Technical Specifications published by and its member organizations. APPLE-1003, 31.

B. Features of 4G/LTE and Older Networks

The '767 patent describes several concepts common to both 4G/LTE and 5G/NR technologies. A review of some such concepts is presented below.

1. *Resource Grid and Frame Structure*

In both 4G/LTE and 5G/NR, radio resources for transmission are represented on a time-frequency resource grid. The grid's horizontal axis denotes time, whereas the vertical axis denotes the frequency domain (APPLE-1010, [0191]-[0196], Fig. 6, below). The smallest unit is called a "resource element" (or

RE). Each RE spans one OFDM symbol in time and one subcarrier in the frequency domain (APPLE-1011, 5:27-30). As shown, a resource block (RB) consists of 84 resource elements (REs) spanning 12 contiguous subcarriers and 7 contiguous OFDM symbols. APPLE-1003, 32-33.

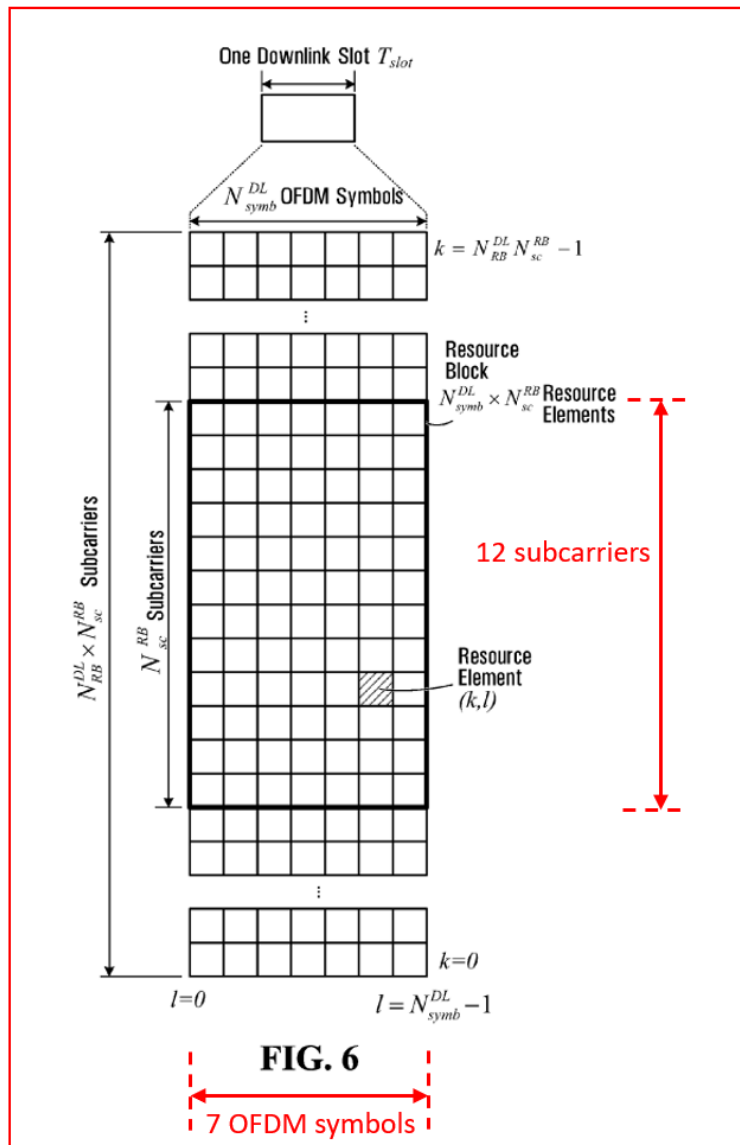

Weng, Fig. 6, Annotated

In the frequency domain, the frequency span of a subcarrier is called “subcarrier spacing.” Within the time domain, the radio resources are scheduled using time units such as frame, subframe, slot, and symbol, as shown in the below frame structure. APPLE-1003, 34.

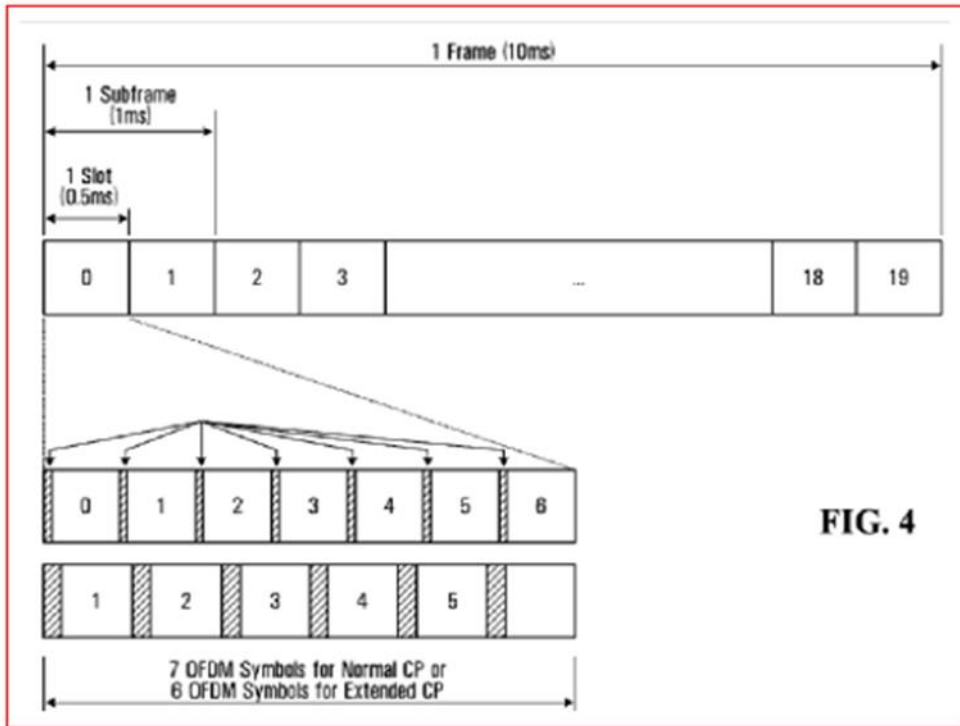

Weng, Fig. 4.

2. Subcarrier Spacing

In a network, subcarrier spacing may correlate with the duration of a symbol or slot. For example, in 4G/LTE, a radio frame is 10 ms long, with 10 subframes per radio frame. Each subframe contains two slots and typically 14 OFDM symbols (APPLE-1010, [0178]-[0180]; APPLE-1003, 35). The standard

subcarrier spacing is 15 kHz, corresponding to a symbol duration of 66.7 μ s, though other spacings like 7.5 kHz are also used, resulting in different frame structures (APPLE-1012, 9:19-31; APPLE-1003, 35).

3. *Paging*

Paging in wireless networks is used by UEs to conserve battery power. Paging involves the UE switching to idle mode when no data has been exchanged with the base station for a period of time, and thereafter while in idle mode, the UE periodically checking for paging messages from the base station. During this time, the base station pages the UE when desiring for the UE to receive downlink messages/data from the network. If a paging message is detected, the UE switches back to active mode to exchange data. These checks occur during specified "paging occasions," (or POs) within a "paging cycle". The paging occasion may be a subframe within a "paging frame," with cycle durations ranging from a few subframes to many radio frames, determined by the UE's ID (APPLE-1010, [0228]-[0229], [0235]-[0236]). This mode of operation, where the UE needs to monitor only the POs within paging cycles to conserve energy, is referred to as discontinuous reception (DRX), and the time interval between monitoring POs by a specific UE is referred to as a discontinuous reception (DRX) cycle. APPLE-1009, p.8-10, 39. APPLE-1003, 36.

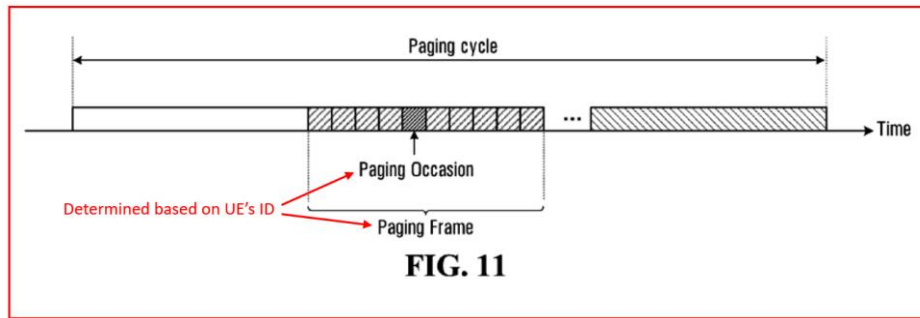

Weng, Fig. 11, Annotated.

4. *Monitoring of Physical Downlink Control Channel (PDCCH)*

The resource grid is divided into a control region for transmitting and receiving control information (e.g., paging scheduling information) and a data region for transmitting and receiving data (e.g., paging messages). In the time domain, a subframe can be split into these regions, with the control region typically residing in the first 1-4 symbols. APPLE-1007, [144]; APPLE-1003, 37.

The control region may contain physical downlink control channels (PDCCHs) for transmitting downlink control information (DCI), which helps locate and decode resources on subsequent physical downlink shared channels (PDSCHs). APPLE-1010, [0226]; APPLE-1007, [104]; APPLE-1003, 38. In paging, the PDCCH carries paging scheduling information, and the PDSCH carries paging messages. APPLE-1007, [105]; APPLE-1003, 38.

A UE typically does not know where its PDCCH resides within the control region, as different PDCCHs in the control region may be directed to different

UEs. Each PDCCH occupies different resource elements in the grid. (APPLE-1007, Fig. 4, [121]; APPLE-1003, 39.

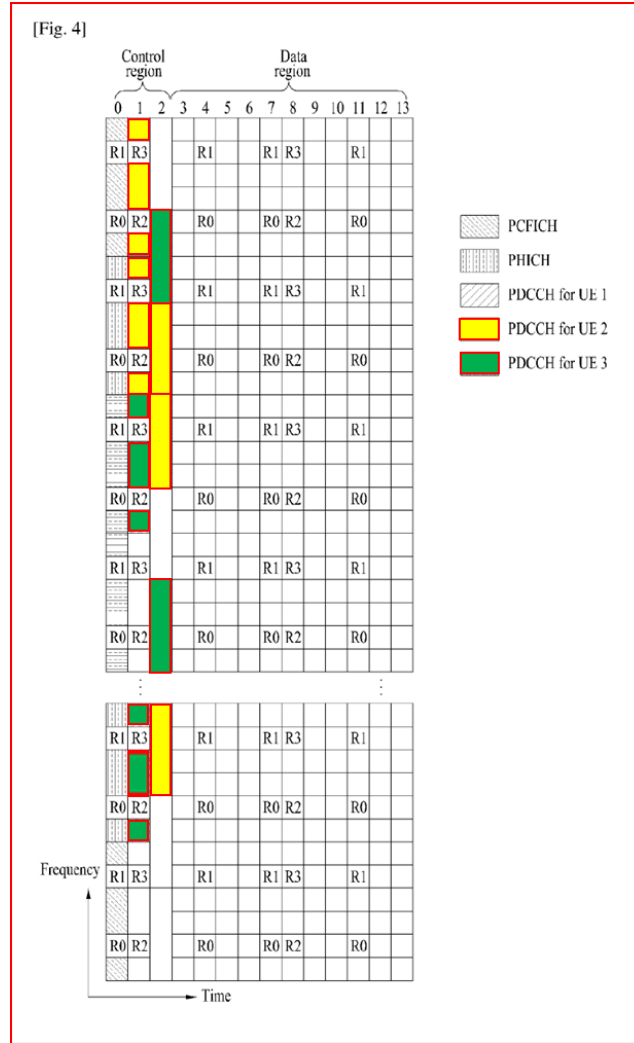

You, Fig. 4, Annotated.

The UE must search for its PDCCH through the control region, known as the "PDCCH search space," by decoding each possible PDCCH space to determine if any are encoded with its identifier. APPLE-1003, 40; APPLE-1007, ¶117. These possible PDCCH spaces are called "PDCCH candidates," suggesting any may contain DCI for the UE. APPLE-1003, 40. Different

PDCCH search spaces can be defined, either for all UEs in a cell ("common search space" or "CSS") or for specific UEs ("UE-specific search space" or "USS"). APPLE-1003, 40; APPLE-1007, ¶¶117, 119 (Table 9).

To find DCI intended for it, the UE monitors the PDCCH search space and attempts to decode each PDCCH. This process, known as blind detection, continues until a PDCCH passes an error check with the cyclic redundancy check (CRC) code scrambled by the UE's identifier. If none are found, the UE continues to monitor the next subframe's control region. APPLE-1003, 41; APPLE-1007, ¶121.

In monitoring, the UE checks for its identifier information, referenced as Radio Network Temporary Identity (RNTI), which is "the information indicating the UE to which the Downlink Control Information (DCI) transmitted on PDCCH is addressed." APPLE-1020, ¶¶[0010], [0213]. The specific type of RNTI that is used for paging is referred to as P-RNTI, which indicates to a UE whether or not a DCI message on the PDCCH is intended for paging. APPLE-1020, ¶[0213]; APPLE-1003, 42.

In practice, during paging, the UE initiates a reception (Rx) process to monitor (i.e., blindly decode) the PDCCH search space at a paging occasion (PO). If no paging indicator is found in the control region, the UE turns off the Rx process and waits for the next paging occasion. If DCI is detected, the UE

decodes the corresponding PDSCH to obtain the paging message. APPLE-1003, 43; APPLE-1010, ¶¶257-260.

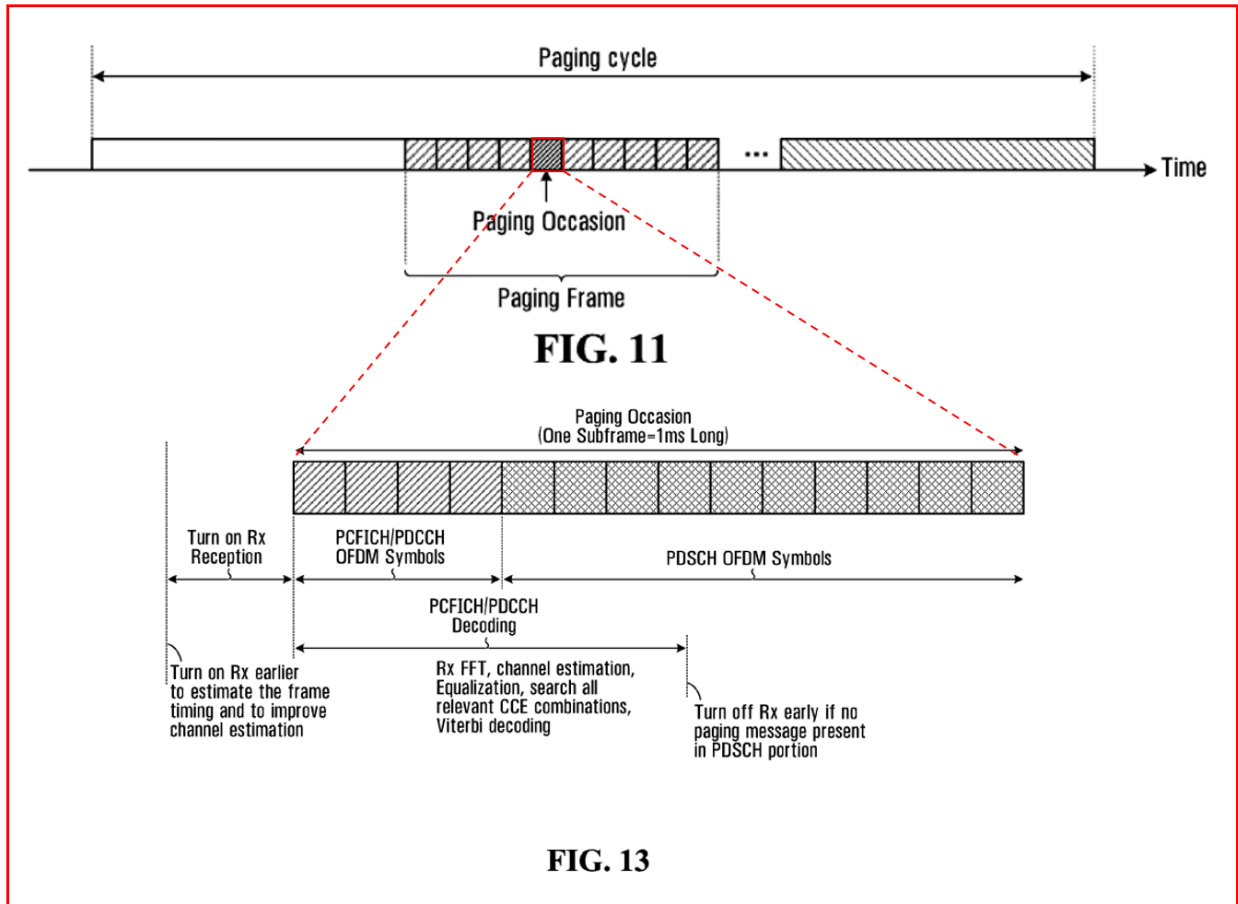

Weng, Figs. 11, 13, Annotated

5. Coverage Enhancement (CE)

Conventional 4G/LTE includes a coverage enhancement (CE) mode where a base station may repeat signal transmissions, allowing a UE to attempt repeated receptions to improve decoding success. APPLE-1013, 13:22-24, 14:3-15:11, 15:23-16:8, Fig. 6. This is beneficial for weak signal reception, such as at the cell edge. APPLE-1003, 44. In CE mode for paging, the same

PDCCH may be repeatedly transmitted in multiple common search spaces (CSSs) across several subframes, enabling a UE to monitor these CSSs during paging occasions. See APPLE-1007, ¶¶186-200; APPLE-1003, 44.

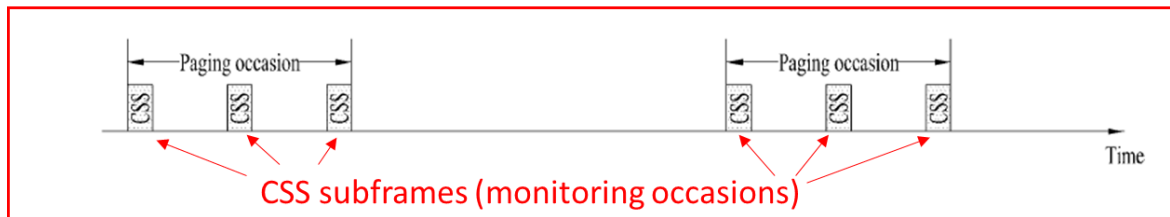

You, Fig. 8, Annotated.

C. 5G/NR Networks

1. *Configurable Numerology*

Due to various factors, including a wide range of available frequency bands (APPLE-1015, ¶¶33, 40), the 5G system supports configurable numerology, including variable subcarrier spacing and symbol duration. *Id.*, ¶57; APPLE-1016, p. 1; APPLE-1003, 45. For example, during time period 90 in the figure below, bandwidth is divided into four subbands with 7.5, 15, 30, and 60 kHz subcarrier spacings, respectively. During time period 92, a new division creates two subbands with different subcarrier spacings. APPLE-1016, ¶35, Fig. 1. Each subcarrier spacing corresponds to a different symbol and/or slot duration because different subcarrier spacings lead to different

symbol durations. APPLE-1017, ¶72; APPLE-1024, Table 2 (reproduced below); APPLE-1022, ¶71; APPLE-1003, 45.

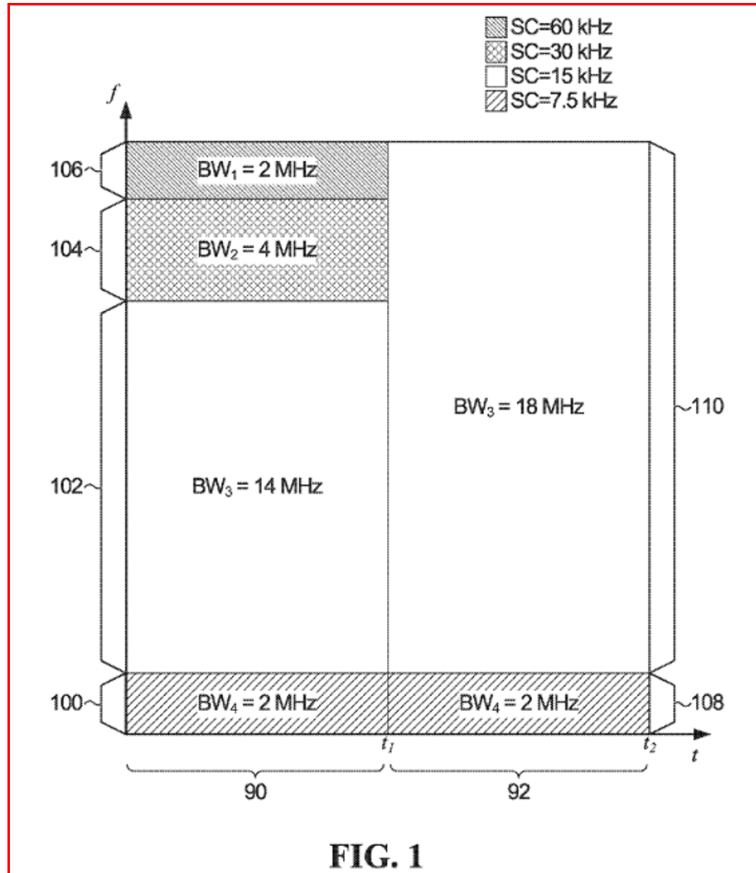

Islam, Fig. 1.

Table 2. Candidate numerology sets

Subcarrier-spacing	15 KHz	60 KHz	75 KHz	120 KHz	240 KHz	375 KHz
OFDM symbol length (μs) (w/o CP)	66.67	16.67	13.33	8.33	4.17	2.67
CP Length (ns)	4687	1172	938	586	293	188

R1-165162 (APPLE-1024), Table 2

2. Various Frame Structures

As discussed *supra*, different subcarrier spacings (i.e., numerologies) result in different frame structures. Thus, 5G's flexible numerology allows for multiple frame structures to schedule DCI transmission/monitoring, such as paging scheduling information. APPLE-1018, ¶¶155-163 (Tables 1-3); APPLE-1003, 46. The '767 patent's portrayal of this flexibility as inventive is unfounded, as it already existed in prior art, including *Yeo*, *Liu*, *Fwu*, and *Pelletier*. APPLE-1003, 46. For instance, *Yeo* describes “acquiring system information using numerology associated with the control channel among a plurality of numerologies that the terminal supports,” as well as using different frame structures resulting from different subcarrier spacings. APPLE-1005, 4:67-5:3, FIGs. 2B-2D; APPLE-1006, FIGs. 3b-3d, [0474].

III. THE '767 PATENT

A. Summary

The '767 patent describes a method and device for paging transmission in a communication system with multiple numerologies, which include various subcarrier spacings and corresponding symbol time durations (APPLE-1001, 1:15-18, 1:34-37). It outlines a process for determining paging transmission opportunities based on the numerology used (*Id.*, 2:1-9). Specifically, it claims: (i) using a first signaling to schedule a paging message; (ii) monitoring the first signaling in X time intervals; and (iii) using location of a subband associated with

the first signaling to determine the X time intervals. *Id.*, 23:2-20; APPLE-1003, 47.

As to the first aspect (i), annotated FIG. 8 below shows that the **first signaling** determines scheduling information for the **first radio signal** (APPLE-1001, 19:54-64). This signaling can be physical layer signaling, like DCI (downlink control information), transmitted via a **PDCCH** (*Id.*, 20:8-14). The first radio signal carrying the paging message may be sent on a **PDSCH** (*Id.*, 20:18-19). The “**second radio signal** [can be] transmitted through a **Physical Broadcast channel (PBCH)**” and carry either “**Master Information Block Information (MIB) information**” or “**System Information Block Information (SIB) information.**” *Id.*, 5:37-44. APPLE-1003, 48.

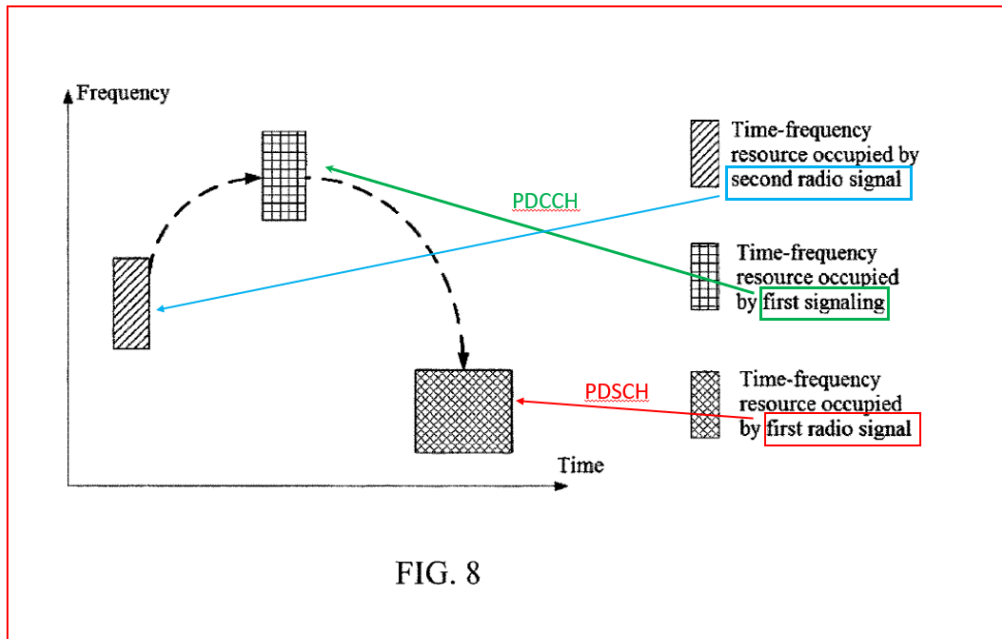

Second concept (ii) is depicted below in annotated FIG. 6 (below), where

each filled rectangle signifies a paging time interval monitored by a specific UE within a particular time window. APPLE-1001, 17:47-54. For instance, UE#2 monitors a first signaling in X2 time intervals, which are part of time window #b. APPLE-1001, 17:47-56, 17:63-64. APPLE-1003, 49.

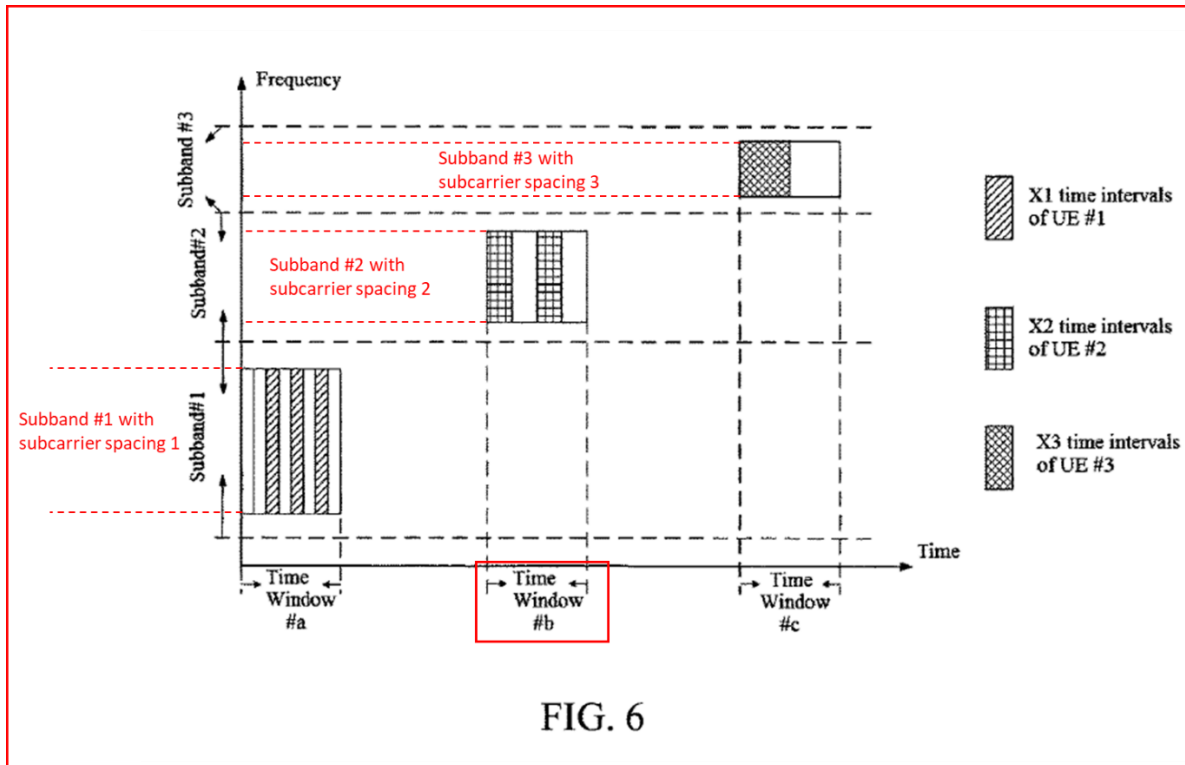

Regarding concept (iii), although the '767 Patent claims that the location of a subband is used for determining X, the patent does not explicitly describe how the determination is made based on the location of the subband. APPLE-1003, 50. Rather, the '767 patent states that, for each UE, the subband of the frequency domain resource used for transmitting the first signaling “includes a positive integer number of consecutive subcarriers in frequency domain.” APPLE-1001,

17:58-59. Annotated FIG 7 illustrates a special case ($X=1$) for using the subcarrier spacing to determine the X time intervals. *Id.*, 18:49-54. Specifically, each UE (UE_a, UE_b, UE_c, or UE_d) is associated with a respective time window. *Id.*, 18:55-64, Fig. 7. The subcarrier spacing associated with each UE affects how to divide the respective time window into Y time intervals, and the feature ID of the UE is used to determine which one of the Y time intervals includes the $X=1$ time interval. *Id.* The '767 patent further clarifies that the time length of each X time interval is correlated with the subcarrier spacing. *Id.*, 19:7-10. Thus, subcarrier spacing determines both the time-domain location (i.e., which Y time interval) and the duration (i.e., time length) of each X time interval. APPLE-1003, 50.

	Index of $X=1$ time interval in the first time window			
	Feature ID=a	Feature ID=b	Feature ID=c	Feature ID=d
$Y=1$	0	0	0	0
$Y=2$	0	1	0	1
$Y=4$	0	1	2	3
$Y=8$	1	3	5	7
$Y=16$	2	6	10	14

This table illustrates, for example, that for a UE with Feature ID=b, if the time window is divided into $Y=16$ time intervals, the $X=1$ paging occasion is at interval no. 6 of the time window spanned by the 16 intervals numbered 0, 1,...,15.

FIG. 7

B. Brief Prosecution History

During prosecution, the application received a first-action allowance. APPLE-1002, pp. 99-102. A published application associated with *Yeo* was cited

during prosecution, but not used in a rejection, or substantively discussed at any level. *TS36* and *Mallick* were never considered. APPLE-1003, 51.

C. Claim Construction

All claim terms should be construed according to the *Phillips* standard. *Phillips v. AWH Corp.*, 415 F.3d 1303 (Fed. Cir. 2005); 37 C.F.R. §42.100. Although Petitioner has construed the claim terms “receiver module” and “transmitter module” under 35 U.S.C. 112(f), Petitioner also demonstrates that prior art references render obvious the claims, regardless of whether the constructions offered by Petitioner are adopted.² Thus, to resolve unpatentability of the claims at issue, it is not necessary to endorse or refute these constructions, nor is it necessary to even resolve whether these terms are subject to 112(f). *Wellman, Inc. v. Eastman Chem. Co.*, 642 F.3d 1355, 1361 (Fed. Cir. 2011). Still and in the spirit of offering a full record, Petitioner advances the following constructions for these terms.

Petitioner construes the term “receiver module” under 112(f). “The standard is whether the words of the claim are understood by persons of ordinary skill in the

² Apple is not conceding that the Challenged Claims satisfy all statutory requirements, such as 35 U.S.C. §112, nor waiving arguments concerning other ineligible grounds nor constructions.

art to have a sufficiently definite meaning as the name for structure." *Williamson v. Citrix Online, LLC*, 792 F.3d 1339, 1349, 115 USPQ2d 1105, 1111 (Fed. Cir. 2015). In *Williamson*, the Federal Circuit found that the term "distributed learning control module" is a means-plus- function limitation that performs three specialized functions (i.e., "receiving," "relaying," and "coordinating"), and explained that "[w]here there are multiple claimed functions, as we have here, the [specification] must disclose adequate corresponding structure to perform all of the claimed functions." *Id.*, 115 USPQ2d at 1115.

To the claimed "**first receiver module**," the '767 Patent claims attribute the function of monitoring ("to monitor..."). And, correspondingly, for performing this function, the '767 Patent specification describes the following generic structure: "[t]he first receiver module 901 includes the transmitter/receiver 456 (including the antenna 460), the receiving processor 452 and the controller/processor 490 shown in FIG. 4. ... the first receiver module 901 monitors a first signaling..." APPLE-1001, 20:59-62, 66-67.

To the claimed "**second receiver module**," the '767 Patent claims attribute the function of receiving ("to receive..."). And, correspondingly, for performing this function, the '767 Patent specification describes the following same generic structure: "the transmitter/receiver 456 (including the antenna 460), the receiving processor 452 and the controller/processor 490 shown in FIG. 4. ... the second

receiver module 902 receives a first radio signal...” APPLE-1001, 20:62-65, 20:67-21:1.

Similarly, Petitioner construes the term “**transmitter module**” under 35 U.S.C. 112(f). To the “first transmitter module,” the ’767 Patent claims attribute the function of “to transmit,” which it describes as performed by the following generic structure: “the transmitter/receiver 416 (including the antenna 420), the transmitting processor 415 and the controller/processor 440 shown in FIG. 4.” APPLE-1001, 21:51-54; CFR 42.104(b). To the “second transmitter module,” the ’767 Patent claims attribute the function of “to transmit,” which it describes as performed by the following same generic structure: “the transmitter/receiver 416 (including the antenna 420), the transmitting processor 415 and the controller/processor 440 shown in FIG. 4.” APPLE-1001, 21:54-58; CFR 42.104(b).

IV. LEVEL OF ORDINARY SKILL IN THE ART

As of its earliest priority date—April 19, 2017—a person of ordinary skill in the art (POSITA) for the ’767 patent would have had a bachelor’s degree in electrical engineering, computer engineering, computer science, or a similar field, along with two years of experience designing or developing wireless networks, including long-term evolution LTE/4G and 5G new radio (NR) cellular

technology. Additional years of experience could substitute for an advanced-level degree (and vice versa). APPLE-1003, 27-30.

V. THE CHALLENGED CLAIMS ARE UNPATENTABLE

A. [GROUND 1] *Yeo* and *TS36* render obvious claims 1, 4-6, 9-11, 14-16, 19, and 20

1. *Yeo*

Yeo relates to, among other things, “paging in wireless cellular communication system” – and is therefore in the same technology area as the ’767 Patent. APPLE-1005, Title; APPLE-1006, [0013]. Like the ’767 Patent, *Yeo* addresses, in the relevant portions, paging transmission in a “5G communication system... for supporting a plurality of numerologies or subcarrier spacings in one system. APPLE-1005, 3:12-16, APPLE-1006, [0014]. As background information, *Yeo* describes the paging procedure employed in 4G LTE systems, and then extends the concept to adapt to variable numerologies available in 5G NR systems. APPLE-1003, 65-66. For example, with reference to FIG. 3J, reproduced below with annotations, *Yeo* describes that in an efficient paging procedure, a terminal (or user equipment (UE)) wakes up for “a little while in a predetermined time interval... to observe the paging information from the network, allowing the terminal...to be...idle...for most of the time.” APPLE-1005, 53:8-12; APPLE-1006, [0455]. For this, *Yeo*, adopts the basic paging structure of LTE, noting that a

paging occasion (PO) is “a **subframe** in which the PDCCH [is] configured [to transmit information that] a paging message exists,” and a **paging frame (PF)** is “one radio frame including one or more POs.” The UE is described as being able to “observe one PO per discontinuous reception (DRX) period.” APPLE-1005, 53:12-20; APPLE-1006, [0455]. APPLE-1003, 66.

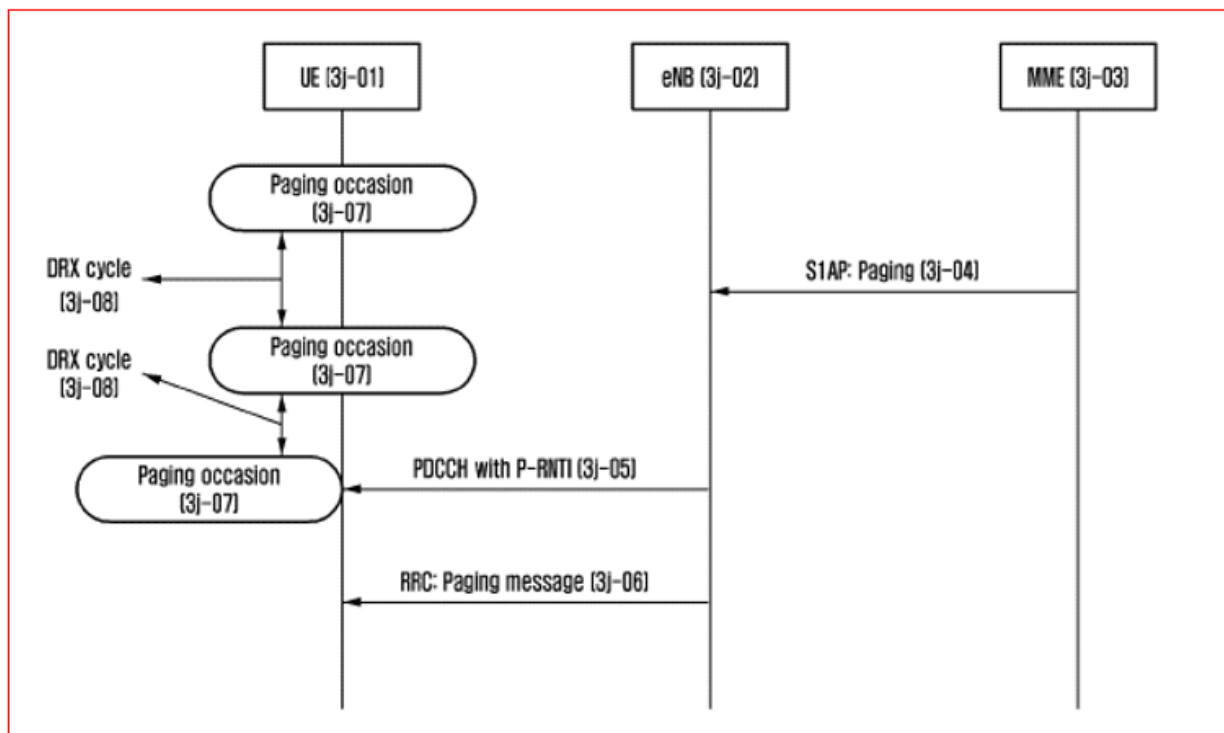

Yeo, Fig. 3J.

The structure of the **paging frame** and **PO subframe** generally adheres to the basic structure used in LTE with each **radio frame** including multiple **subframes** and each **subframe** including two **slots**, each of which includes multiple OFDM symbols. APPLE-1005, FIG. 3B (annotated below); APPLE-1006, FIG. 1a. Each

OFDM symbol includes multiple **resource elements** that each having a different frequency range. The frequency range corresponding to each resource element in an OFDM symbol is referred to as a **subcarrier**, and the width of the frequency range is referred to as subcarrier spacing. APPLE-1003, 67.

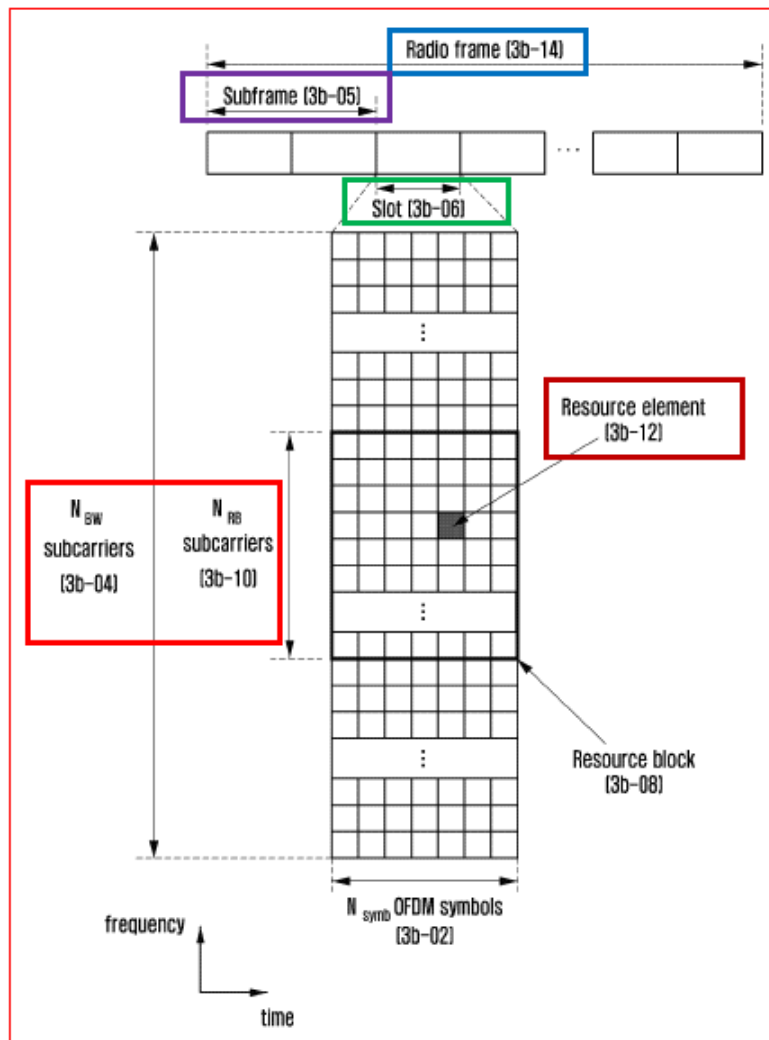

Yeo, FIG. 3B, Annotated

Yeo extends the above frame structure to the variable numerology concept in 5G, where the length or duration of each OFDM symbol varies with subcarrier spacing. Specifically, FIG. 3C (annotated below) shows resource elements for subcarrier spacings 15KHz, 30 KHz, and 60Khz, and it is noted that “the subcarrier spacing and the length of the OFDM symbol have a reciprocal relationship with each other.” APPLE-1005, 43:49-62; APPLE-1006, [0383]; APPLE-1003, 68.

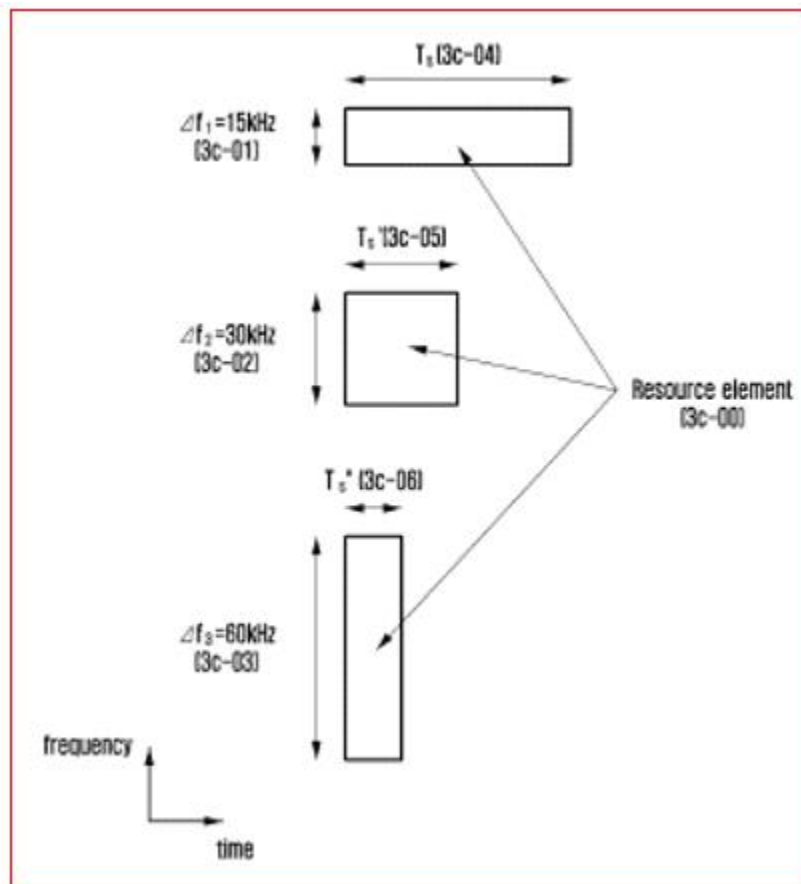

Yeo, FIG. 3C

Because the OFDM symbol durations are different for different subcarrier spacings, a UE needs to know the numerology information to decode the information received during paging occasions. More specifically, with reference to its FIG. 3H and 3I (annotated below) as well as FIGs. 3L and 3M, *Yeo* describes that a base station “transmits **information on numerology** (e.g., **subcarrier spacing**, etc.) for the physical layer channel used for paging,” prior to transmitting any “**control information** and data for paging.” The information on numerology can include a Master Information Block (**MIB**) or a system information block (**SIBx**). A terminal (or user equipment UE) receives the “information on the physical layer numerology” and upon determining that the terminal supports the numerology, proceeds to receive “the **control information** and **data** reception.” APPLE-1005, 56:12-27; APPLE-1006, [0452]; APPLE-1003, 69. The data for paging or “**paging message**” is transmitted on the **PDSCH**, and scheduling information on the **PDSCH** can be acquired from the **PDCCH**. APPLE-1005, 3:48-50; APPLE-1006, [0013].

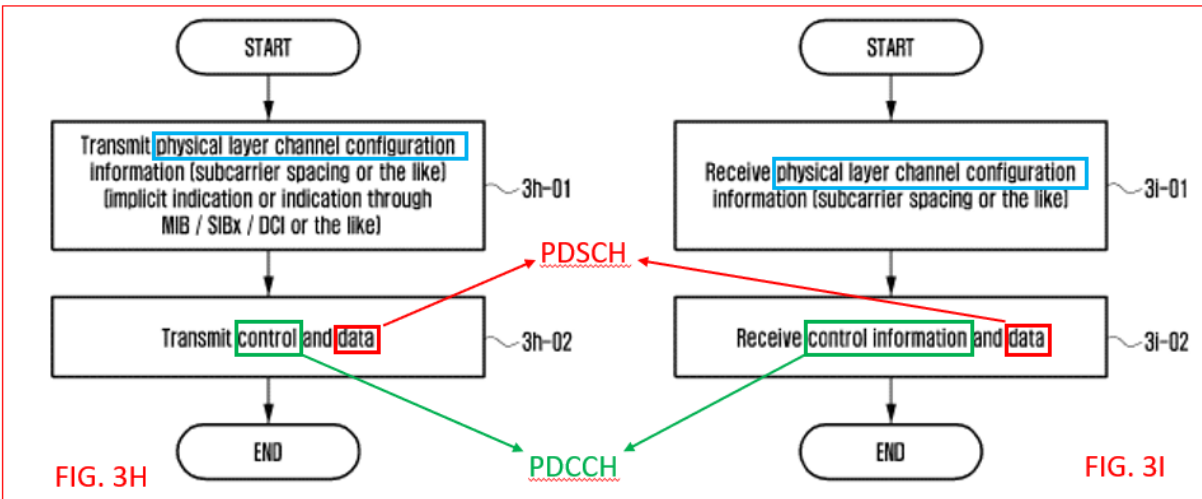

Yeo, Figs. 3H and 3I, Annotated

Yeo further describes various types of UEs that are served by the wireless network, including UE type that supports massive machine type communication (mMTC), UE type that supports multiple-input-multiple-output (MIMO), UE type that supports enhanced mobile broadband (eMBB), and UE type that supports ultra-reliable and low-latency communications (URLLC). APPLE-1005, 2:13-23, 10:10-14; APPLE-1006, [0004], [0027]. APPLE-1003, 70. Massive MTC (mMTC) is a type of MTC that supports mass communications among connected devices. APPLE-1005, 29:5-7; APPLE-1006, [0211]. The frequency subband in use for a UE can vary with the type of devices/communications and associated requirements, and thus be allocated accordingly. See, for example, APPLE-1005, FIG. 1D, 9:60-10:21; APPLE-1006, FIG. 1d, [0027]; APPLE-1003, 70.

Yeo is analogous art to the '767 Patent. Indeed, comparison of *Yeo*'s FIGS.

3H and 3I with FIG. 8 from the '767 Patent (*supra*) reveals that *Yeo* describes the overall solution that the '767 purports to solve – determining “transmission opportunities of paging according to the numerology employed by the paging.” APPLE-1001, 2:1-5; APPLE-1003, 71.

2. *TS36*

TS36 is a Technical Specification document published by the 3GPP and pertains to Evolved Universal Terrestrial Radio Access (E-UTRA) UE procedures in idle mode. E-UTRA technology is well-known to be associated with 4G/LTE. APPLE-1019, 1:25-31.

TS36 specifically describes details of paging procedures, such as details of the DRX mode referred to in *Yeo*. APPLE-1009, p.39. For example, *TS36* specifically covers details of implementations where a paging frame (PF) contains “one or multiple Paging Occasion(s)” and the UE “needs only to monitor one PO per DRX cycle” – as also described in *Yeo* with respect to FIG. 3J (*supra*). APPLE-1009, p.39; APPLE-1005, 53:12-20; APPLE-1006, [0455]. As discussed in **Section III.B.4**, *supra*, monitoring the PO includes monitoring PDCCH within the PO for the identifier P-RNTI - which indicates to a UE whether or not paging is scheduled in the PO for the UE. The UE performs the paging message reception in a Paging Narrowband (PNB) that is within the subband assigned to the UE.

APPLE-1009, p.39. The subband can be assigned depending on the type of services of services—such as enhanced mobile broadband (eMBB), mMTC, ultra-reliable and low-latency communications (URLLC), etc.—provided by the UE. APPLE-1005, FIG. 1D, 9:60-10:21; APPLE-1006, FIG. 1d, [0027]; APPLE-1003, 72.

TS36 provides the formulae that are used for determining PF, PO, and PNB in implementing paging in DRX – based on DRX parameters provided as portions of System Information (SI). Specifically, the system frame number (SFN) of the radio frame corresponding to PF is determined as:

$$\text{SFN mod } T = (T \text{ div } N) * (\text{UE_ID mod } N)$$

An index i_s that points to the PO within the PF is determined as:

$$i_s = \text{floor}(\text{UE_ID}/N) \text{ mod } N_s$$

Notably, the determination of the PF and PO depends explicitly on an identifier (UE_ID) of the UE – signifying that each UE has a designated PF and PO in a paging cycle. APPLE-1009, p.39; APPLE-1003, 73.

TS36 also shows how the determination of PO is affected by the location of the system bandwidth. For example, TS36 describes that “if P-RNTI is transmitted on MPDCCH with system bandwidth > 3MHz”, the paging occasions can be

determined as per the following table (APPLE-1009, page 40, annotated, APPLE-1003, 74):

UE-specific Paging Occasions

N_s	PO-when $i_s=0$	PO-when $i_s=1$	PO-when $i_s=2$	PO-when $i_s=3$
1	9	N/A	N/A	N/A
2	4	9	N/A	N/A
4	0	4	5	9

Number of UEs that can be paged using a paging frame

Paging occasions for a given UE depending on whether 1, 2, or 4 UEs are paged using a paging subframe

TS36 further describes that “if P-RNTI is transmitted on MPDCCH with system bandwidth of 1.4MHz and 3MHz”, i.e., for system bandwidths narrower than the previous case of bandwidth greater than 3 MHz, the corresponding paging occasions can be determined as per the following table (APPLE-1009, page 41, annotated, APPLE-1003, 75):

UE-specific Paging Occasions

N_s	PO-when $i_s=0$	PO-when $i_s=1$	PO-when $i_s=2$	PO-when $i_s=3$
1	5	N/A	N/A	N/A
2	5	5	N/A	N/A
4	5	5	5	5

Number of UEs that can be paged using a paging frame

Paging occasions for the same UE depending on whether 1, 2, or 4 UEs are paged using a paging subframe

Thus, TS36 describes that determination of the time intervals corresponding to the POs depends on the system bandwidth. It was also well-known to a POSITA as of the Critical Date that different system bandwidths could be allocated

to different locations in the frequency domain (with the allocation varying over time) and the numerology could depend on the allocation. *See* for example, FIG. 1 of *Islam* (**Section II.C**, *supra*), which shows that allocations change from one time period to another. APPLE-106, FIG. 1. As such, *TS36* makes it clear that the determination of paging occasions depends explicitly on the width (and hence location) of the system bandwidth. APPLE-1003, 76.

3. *Combining Yeo and TS36*

Yeo describes that a “PF is defined as one radio frame including one or more POs,” and that a UE “can observe one PO per discontinuous reception (DRX) period,” but *Yeo* omits various implementation details – e.g., how a UE identifies the one or more POs in a PF. APPLE-1005, 53:14-17; APPLE-1006, [0455]; APPLE-1003, 77. Yet, such details would be required by or at least helpful to a POSITA seeking to implement the technology described in *Yeo*—for example, to have a UE monitor a PO where PDCCH is encoded with P-RNTI (as described with respect to FIG. 3J). Such details were well-known by the Critical Date, for example, through technical specifications published by 3GPP working groups in the relevant technical areas. APPLE-1003, 77.

Yeo specifically mentions “long term evolution (LTE) or evolved universal terrestrial radio access (E-UTRA) of the 3GPP,” (APPLE-1005, 11:48-49; APPLE-

1006, [0036]) as well as paging operations of a UE in an idle mode (APPLE-1005, 3:39-59; APPLE-1006, [0013]), and a POSITA would have turned to *TS36* to implement these feature sets at least because *TS36* specifically provides the requisite technical specifications for the paging operations described in *Yeo*.

APPLE-1003, 77. Indeed, a POSITA would have known that the 3GPP Technical Specification Group (TSG) had already approved standardization that “specifies the Access Stratum (AS) part of the Idle Mode procedures applicable to a UE”, which provides the paging details of UE in idle mode compatible with other aspects of the 3GPP cellular standard. APPLE-1009, p.6.*TS36* even bears the title “Evolved Universal Terrestrial Radio Access (E-UTRA); User Equipment (UE) procedures in idle mode” and supplies details of the implementations that are missing from *Yeo*. APPLE-1003, 78.

An example illustrates. While *Yeo* (i) describes the exact same equation for determining a PF as *TS36*, and (ii) notes that a PF includes “one or more POs,” *Yeo* does not specifically describe how those “one or more POs” are determined by a UE (*compare Yeo*’s “equation 3” in column 53 to the equation “ $SFN \bmod T = (T \div N) * (UE_ID \bmod N)$ ” on page 39 in *TS36*). *TS36* fills in this gap by describing that the index “ i_s pointing to PO” is given by the equation “ $i_s = \text{floor}(UE_ID/N) \bmod N_s$.”

Overall, a POSITA would have referred to the equations and tables described in *TS36* to determine the implementations details associated with implementing the paging procedure described in *Yeo*. APPLE-1009, p.39-40. The combination would yield predictable results by allowing for different UE-specific POs within PFs of *Yeo*'s system as a function of the location of the paging subband. APPLE-1003, 80. Indeed, A POSITA would have had a reasonable expectation of success in combining *Yeo* and *TS36* at least because the combination (referred to herein as "*Yeo-TS36*") leads to the predictable result of determining the UE-specific POs within the PF of *Yeo*. APPLE-1003, 79.

1. *Independent Claim 1*

[1pre]: "A method in a User Equipment (UE) for paging, comprising:"

Yeo-TS36 renders obvious [1pre]. As shown in FIG. 3I and 3J (reproduced above), *Yeo* describes a method in a UE for paging, for example, to monitor a PDCCH in a paging occasion. APPLE-1005, FIGs. 3I and 3J, 52:50-54; APPLE-1006, FIGs. 5h and 5i, [0452]; APPLE-1003, 81.

[1a]: "monitoring a first signaling in X time intervals; and"

Yeo-TS36 renders obvious [1a]. *Yeo* describes that "[i]n order to observe the paging information, the terminal wakes up for a little while at a

predetermined time interval to observe control signaling.” APPLE-1005, 3:40-43; APPLE-1006, [0013]. *Yeo*’s “PDCCH configured as P-RNTI” constitutes or at least renders obvious the claimed “first signaling” because *Yeo* describes that in order to receive paging messages, “specific mapping location in the frequency domain, the modulation scheme, or the like may be determined based on the DCI transmitted through the PDCCH.” APPLE-1005, 14:5-8, APPLE-1006, [0055]; APPLE-1003, 82.

Yeo defines each paging occasion “as a subframe in which the PDCCH [is] configured as the P-RNTI,” and a paging frame as “one radio frame including one or more POs.” APPLE-1005, 53:14-17; APPLE-1006, [0455]. As such, the time intervals associated with the POs in *Yeo* constitute or at least render obvious the “X time intervals.” APPLE-1003, 83.

In the Complaint filed against Apple in the Western District of Texas, Patent Owner explicitly maps “first signaling” to “paging DCI” and “P-RNTI,” and the “X time intervals” to “PDCCH monitoring occasions” – which, as described above, are described by *Yeo*. APPLE-1023, ¶¶81, 83, 85, 257; APPLE-1003, 84.

[1b]: “receiving a first radio signal;”

Yeo-TS36 renders obvious [1b]. In *Yeo*, “[t]he paging message is transmitted through the PDSCH, and scheduling information on the PDSCH can be acquired from the PDCCH configured as P-RNTI.” APPLE-1005, 53:48-51; APPLE-1006, [0013].

Notably, *Yeo* describes that “downlink data may be transmitted on a physical downlink shared channel (PDSCH) that is a physical channel for downlink data transmission.” APPLE-1005, 14:1-3; APPLE-1006, [0055]. From at least this description, a POSITA would have understood that a message on the PDSCH is a radio signal and would constitute or at least render obvious the claimed “first radio signal.” APPLE-1003, 85. Indeed, this is also consistent with the position adopted by the Patent Owner in pending litigation. APPLE-1023, ¶¶81, 83, 84 (equating “first radio signal” to PDSCH).

[1c]: “wherein X is a positive integer;”

Yeo-TS36 renders obvious [1c]. As discussed for [1a], *Yeo* describes a paging frame to include “one or more POs.” APPLE-1005, 53:14-17; APPLE-1006, [0455]. A POSITA would have understood or found obvious that the number of POs would have been a positive integer. APPLE-1003, 86.

[1d]: “the first signaling is used for determining scheduling information for the first radio signal;”

Yeo-TS36 renders obvious [1d]. *Yeo* describes that “[t]he paging message is transmitted through the PDSCH, and scheduling information on the PDSCH can be acquired from the PDCCH configured as P-RNTI.” APPLE-1005, 53:48-51; APPLE-1006, [0013]; APPLE-1003, 87. As described with respect to limitations [1a] and [1b], *Yeo*’s “PDCCH configured as P-RNTI” and/or “DCI transmitted through the PDCCH.” constitute or at least render obvious the claimed “first signaling,” and *Yeo*’s description of the PDSCH constitutes or at least renders obvious the claimed “first radio signal.” This is consistent with what Patent Owner alleges in the pending litigation – noting that in the “Accused Products,” “the first signaling (e.g., paging DCI, P-RNTI) is used for determining scheduling information for the first radio signal.” APPLE-1023, ¶83, 258. APPLE-1003, 87.

[1e]: “the scheduling information comprises at least one of {occupied time-frequency resource, adopted Modulation Coding Scheme (MCS), subcarrier spacing of subcarriers in occupied frequency domain resource};”

Yeo-TS36 renders obvious [1e]. While [1e] recites the scheduling information to include **only one of three** different parameters, *Yeo* describes all three. APPLE-1003, 88.

Yeo describes that the “the scheduling information...is transmitted...through downlink control information (DCI),” and in “DCI format 1” includes “at least one of the following control information”:

- “Resource allocation type 0/1 flag:...The type 0 applies a bitmap scheme to allocate **a resource in a resource block group (RBG) unit**. In the LTE system, a basic unit of the scheduling is the **resource block (RB)** represented by a **time-frequency domain resource** and the RBG includes a plurality of RBs and thus becomes a basic unit of the scheduling in the type 0 scheme. The type 1 allocates a **specific RB within the RBG.**”...
- “**Modulation and coding scheme (MCS)**”

APPLE-1005, 13:21-40; APPLE-1006, [0046]-[0048]; APPLE-1003, 89.

Yeo also describes embodiments in which the scheduling information includes “subcarrier spacing of subcarriers in occupied frequency domain

resource.” For example, *Yeo* describes that “the base station...can include information on the **subcarrier spacing of the PDSCH**...to which the contention resolution message is transmitted in the DCI transmitted to the PDCCH.” This description is generic and not specific to or exclusive of paging messages. And while the PDCCH described above is configured with C-RNTI, a POSITA would have readily understood that it is straightforward to extend the concept to other transmissions including DCI transmitted over PDCCH configured with P-RNTI such that the UE can detect and receive paging. APPLE-1005, 52:10-14, 38-40; APPLE-1006, [0450], [0228]; APPLE-1003, 90.

[1f]: “the first radio signal carries a paging message;”

Yeo-TS36 renders obvious [1f] at least because *Yeo-TS36* renders obvious that “[t]he **paging message** is transmitted through the **PDSCH**” as discussed with respect to [1b]. APPLE-1005, 3:48-49; APPLE-1006, [0464]; APPLE-1003, 91.

[1g]: “the frequency domain resource used for transmitting the first signaling belongs to a first subband;”

Yeo-TS36 renders obvious this feature. As described with respect to limitation [1a], *Yeo*’s “**PDCCH configured as P-RNTI**” constitutes or at least renders obvious the claimed “**first signaling**.” *Yeo* further describes “mapping location in the frequency domain of the PDCCH maybe...transmitted over the

entire system transmission bandwidth.” APPLE-1005, 13:64-67; APPLE-1006, [0054]. As such, a POSITA would have readily understood from this disclosure that the bandwidth for transmitting the PDCCH constitutes or at least renders obvious “the frequency domain resource.” APPLE-1003, 92.

Further, as discussed above in **V.2** *supra*, *Yeo* describes various types of UEs that are served by the wireless network, including UE type that supports massive machine type communication (mMTC), UE type that supports MIMO, UE type that supports enhanced mobile broadband (eMBB), and UE type that supports ultra-reliable and low-latency Communications (URLLC). APPLE-1005, 2:13-23; APPLE-1006, [0004]. Massive MTC (mMTC) is a type of MTC that supports mass communications among connected devices. APPLE-1005, 29:5-7; APPLE-1006, [0211]. The frequency bands in use can vary with the type of devices/communications and associated requirements, and thus be allocated accordingly. APPLE-1005, FIG. 1D, 9:60-10:21; APPLE-1006, FIG. 1d, [0027]; APPLE-1003, 70. *Yeo* describes—with reference to FIG. 1D (annotated below)—“the **subband 1d-06**...for mMTC data transmission.” APPLE-1005, 16:24-36.; APPLE-1006, [0168]; APPLE-1003, 93.

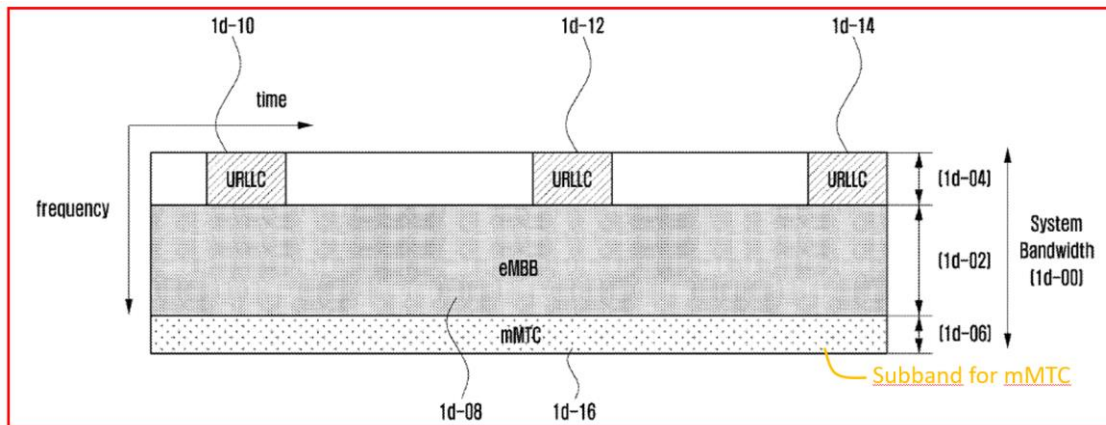

Yeo, FIG. 1D, Annotated

It was well known as of the Critical Date that “a downlink (DL) means a radio transmission path of a signal transmitted from a base station to a terminal,” and a “Master information block (MIB)...includes...[i]nformation on downlink cell bandwidth.” APPLE-1005, 18:56-57, 45:29-35; APPLE-1006, [0182], [0391]-[0394]. It was also well-known as of the Critical Date that downlink information is transmitted over DL transport channels which could include “a Broadcast Channel (BCH), Downlink Shared Data Channel (DL-SDCH) and a Paging Channel (PCH).” APPLE-1021, [0043]; APPLE-1003, 94.

A POSITA would have understood from the description of *Yeo* that because the mMTC transmissions occur within the subband 1d-06, the subband 1d-06 would include the associated DL transport channels including the associated PCH, and the paging transmissions and receptions for mMTC would also take place within the subband 1d-06. APPLE-1003, 95. Further, *TS36* describes that for

MTC (which mMTC is a type of), the **PDCCH** (referred to as MPDCCH) is monitored in a narrower band (referred to as the paging narrowband PNB) within the **subband 1d-06**. As such, a subband for a specific service – such as the subband 1d-06 for mMTC constitutes or at least renders obvious the claimed “first subband.” APPLE-1009, p.39-40; APPLE-1003, 95.

As discussed above in **Section V.A.3**, although *Yeo* describes a paging mechanism in general, as well as a different subband for mMTC services, *Yeo* omits some implementation details, e.g., those specific to the mMTC services. For example, while *Yeo* describes—in the context of paging—that a paging frame “PF is defined as one radio frame including one or more [paging occasions] POs,” and that a UE “can observe one PO per discontinuous reception (DRX) period,” *Yeo* does not specifically describe how a paging channel is determined for particular services such as mMTC. *TS36* provides these details by describing, e.g., that “[i]f P-RNTI is monitored on MPDCCH, the PNB is determined by the following equation: $PNB = \text{floor}(UE_ID/(N*N_s)) \bmod N_n$.” A POSITA would have understood that the PNB refers to the band associated with the paging channel, and as such, would have had a reasonable expectation of success in combining *Yeo* with *TS36* at least because a POSITA would have recognized that the combination leads to the predictable result of implementing the paging channels in mMTC as

described in *Yeo*. APPLE-1003, 96. As such, *Yeo-TS36* renders obvious the foregoing feature.

[1h]: “the first subband comprises a positive integer number of consecutive subcarriers in frequency domain; and”

Yeo-TS36 renders obvious [1h]. *Yeo* describes that information in a “data or a control channel is transmitted” using “a basic structure of a time-frequency domain that is a radio resource region” as shown in FIG. 1D (annotated below) – which shows the arrangement of OFDM symbols within a slot of a subframe, and that each OFDM symbol includes a positive integer number of consecutive subcarriers. APPLE-1005, 12:20-34; APPLE-1006, [0039]-[0040]; APPLE-1003, 97. *Yeo* also describes that “[the DCI] may be transmitted within first N OFDM symbols within the subframe.” Because *Yeo* describes that DCI is “transmitted through the PDCCH,” (*see* APPLE-1005, 14:1-8; APPLE-1006, [0055]), and the PDCCH is transmitted in a service-specific subband (*see* discussion related to limitation [1g]), a POSITA would have readily understood that the service-specific subband would include the subcarriers associated with the corresponding OFDM symbols – the subcarriers constituting “a positive integer number of consecutive subcarriers in frequency domain.” APPLE-1005, FIG. 1A, 12:35-41; APPLE-1006, FIG. 1a, [0060]; APPLE-1003, 97.

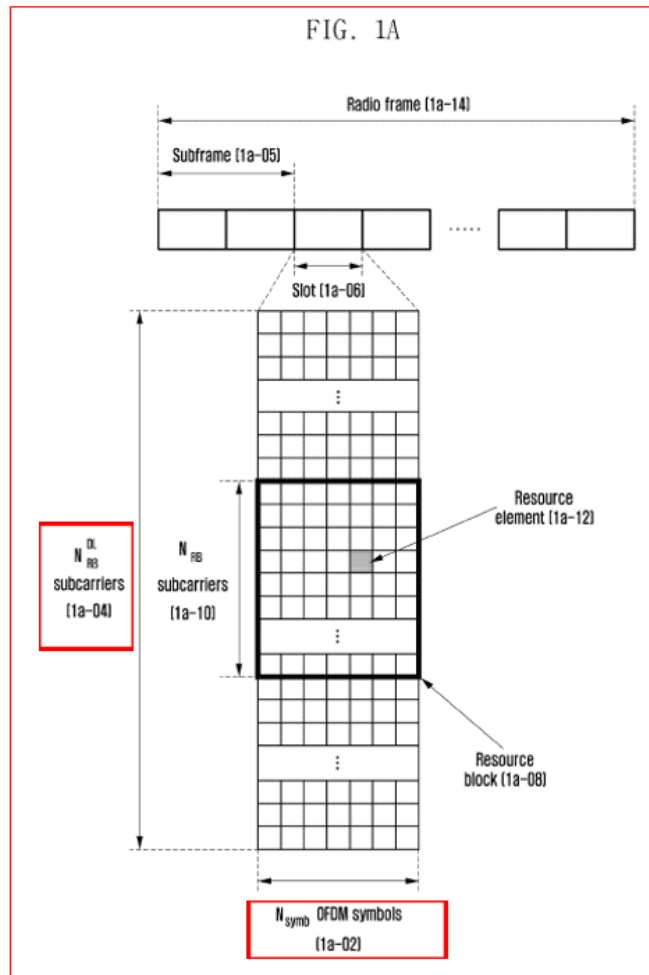

[1i]: “at least one of {location of the first subband in frequency domain, subcarrier spacing of subcarriers included in the first subband} is used for determining the X time intervals.”

Yeo-TS36 renders obvious [1i]. As described with respect to limitation [1a], the time intervals associated with the paging occasions (POs) in *Yeo* constitute or at least render obvious the “X time intervals.” To the extent *Yeo* does not describe the details of how the time intervals associated with the one or more POs are determined for the individual subbands, such details were well-known to a

POSITA as of the Critical Date—as evidenced by the description in *TS36*—and the details make it clear that the location of the corresponding subband is used in determining the **time intervals associated with the one or more POs**.

Specifically, although *Yeo* describes that a “PF is defined as one radio frame including **one or more POs**,” and that a UE “can observe one PO per discontinuous reception (DRX) period,” *Yeo* does not explicitly specify how a UE identifies the **one or more POs**. APPLE-1005, 53:14-17; APPLE-1006, [0455]; APPLE-1003, 98. Specifically, while *Yeo* (i) describes the equation relied upon in *TS36* for determining a PF, and (ii) notes that a PF includes “one or more POs,” *Yeo* does not specifically describe how those “**one or more POs**” are determined by a UE. *TS36*, by contrast, describes the index “*i_s* pointing to PO” is given by the equation “ $i_s = \text{floor}(\text{UE_ID}/N) \bmod N_s$.” APPLE-1003, 98.

Further, *Yeo* also describes that the above 4G concepts can be extended to support various types of services such as enhanced mobile broadband (eMBB), mMTC, ultra-reliable and low-latency communications (URLLC), etc.—as supported by 5G NR—and the requirements for such services can vary. APPLE-1005, 10:10-21; APPLE-1006, [0027]; APPLE-1003, 99. Indeed, *Yeo* also describes—with reference to its FIG. 1D (reproduced above)—dividing the system frequency bands into corresponding subbands for different services, with mMTC

occupying subband 1d-06, for example. APPLE-1005, 16:24-37; APPLE-1006, [0168]; APPLE-1003, 99.

To the extent *Yeo* does not describe the details of how the **time intervals associated with the one or more POs** are determined for the individual subbands, such details were available in *TS36*. Specifically, *TS36* covers implementation details that specify locations of “**one or multiple Paging Occasion(s)**” within a paging frame, and shows how the location of the one or more POs vary depending on the location of the subband. APPLE-1009, p.39-40; APPLE-1003, 100. For example, and as discussed in **V.2 supra**, *TS36* shows that for otherwise-same operating parameters, the **POs** are different in a subband in the **1.4MHz-3MHz** range as compared to the **POs** in a subband that is **above 3MHz**. APPLE-1009, p.39-40; APPLE-1003, 74. Specifically, *TS36* describes that “**if P-RNTI is transmitted on MPDCCH with system bandwidth > 3MHz**”, the paging occasions can be determined as per the following table:

	N_s	PO-when- $i_s=0$	PO-when- $i_s=1$	PO-when- $i_s=2$	PO-when- $i_s=3$
1	1	9	N/A	N/A	N/A
2	2	4	9	N/A	N/A
4	4	0	4	5	9

Number of UEs that can be paged using a paging frame

UE-specific Paging Occasions

Paging occasions for a given UE depending on whether 1, 2, or 4 UEs are paged using a paging subframe

On the other hand, “if P-RNTI is transmitted on MPDCCH with system bandwidth of 1.4MHz and 3MHz”, the corresponding paging occasions can be determined as per the following table:

UE-specific Paging Occasions

N_s	PO-when $i_s=0$	PO-when $i_s=1$	PO-when $i_s=2$	PO-when $i_s=3$
1	5	N/A	N/A	N/A
2	5	5	N/A	N/A
4	5	5	5	5

Number of UEs that can be paged using a paging frame

Paging occasions for the same UE depending on whether 1, 2, or 4 UEs are paged using a paging subframe

APPLE-1009, p.40-41, annotated, APPLE-1003, 75, 100.

As such, *Yeo-TS36* renders obvious that the determination of one or more POs—depends explicitly on the system bandwidth. A POSITA would have readily understood that a change in system bandwidth necessarily results in a change in one or both boundaries of the corresponding frequency band, and hence, in a change of location of the system band. APPLE-1003, 101. Further, a POSITA would have also understood that the designated band for a specific type of device/service (e.g., mMTC) would be the subband allocated to that type of device/service (e.g., the subband 1d-06 discussed with reference to feature [1g]) *Id.* For at least these reasons, a POSITA would have readily understood or found obvious from the description of *Yeo-TS36*, that the determination of one or more POs depends on a location of the system band corresponding to the type of device/service (e.g.,

mMTC), and as such, the combination of the references renders obvious using a “location of the first subband in frequency domain” to determine the X time intervals. APPLE-1003, 101.

2. Claim 4

[4a]: “The method according to claim 1, further comprising: receiving a second radio signal;”

Yeo-TS36 renders obvious [4a]. *Yeo* describes that “data for eMBB, URLLC, and mMTC, which are services to be considered in a 5G or NR system are allocated in frequency-time resources,” and also specifically “allocating frequency and time resources for information transmission in each system.” APPLE-1005, 15:64-16:3; APPLE-1006, [0165]-[0166]. *Yeo* also describes that “base station is the subject performing resource allocation of a terminal,” and that “downlink (DL) means a radio transmission path of a signal transmitted from a base station to a terminal.” APPLE-1005, 18:48-50; APPLE-1006, [0182]. Because *Yeo* is directed to wireless communications, a POSITA would have readily understood or found obvious from these disclosures, that any frequency allocation (e.g., the subband allocation depicted in FIG. 1C and 1D) would be communicated over a radio signal that would constitute or at least render obvious “the second radio signal.” Specifically, *Yeo* describes that “the system information is transmitted in two ways over two different transmission channels. Master

information block (MIB): transmission using PBCH 3d-03” and “System information block (SIB): transmission using PDSCH 3d-04.” APPLE-1005, 45:27-32; APPLE-1006, [0390]-[0392];APPLE-1003, 102.

Patent Owner’s infringement contentions in the related litigation proceeding maps the “second radio signal” to both “MIB information element” as well as a “BCH/BCCH channel.” *Yeo* specifically describes—with reference to FIG. 3D—“a physical broadcast channel (PBCH)...to which a master information block (MIB)...is transmitted.” The MIB includes “[i]nformation on downlink cell bandwidth.” APPLE-1005, 45:29-35; APPLE-1006, [0391]; APPLE-1003, 103.

[4b]: “wherein the second radio signal is used for determining at least one of {location of the first subband in frequency domain, subcarrier spacing of subcarriers included in the first subband}.”

Yeo-TS36 renders obvious [4b]. As discussed for limitations [4a], frequency allocation information (e.g., “location of the first subband” depicted in FIG. 1D) would be communicated as system information over “the second radio signal” communicated over a physical broadcast channel PBCH. APPLE-1003, 103-104. Such a radio signal would have been used by an UE to decode bandwidth for communicating with a base station. For example, *Yeo* describes that “MIB transmitted through the PBCH...includes...[i]nformation on downlink cell bandwidth,” which is then used for communicating DCI information— thereby

disclosing the above feature. APPLE-1005, 45:33-35; APPLE-1006, [0393]-
[0394]; APPLE-1003, 104.

3. *Claim 5*

**[5a]: “The method according to claim 1, further comprising:
receiving a second signaling;”**

Yeo-TS36 renders obvious [5a]. *Yeo* describes—with reference to FIG. 1D (reproduced above)—that “frequency band 1d-00 may be divided and used to transmit services and data in the respective subbands 1d-02, 1d-04, 1d-06,” and also that “[i]nformation related to the subband setting...may be transmitted from the base station **to the terminal** through **higher signaling**.” APPLE-1005, 16:24-29; APPLE-1006, [0168]. Thus, the **higher signaling** described in *Yeo* constitutes or at least renders obvious the claimed “**second signaling**.” APPLE-1003, 105.

[5b]: “wherein the **second signaling is used for determining **Q subbands**, Q being a positive integer;”**

Yeo-TS36 renders obvious [5b]. *Yeo* describes—with reference to FIG. 1D (reproduced above)—that the “frequency band 1d-00 may be divided and used to transmit services and data in the respective subbands 1d-02, 1d-04, 1d-06,” and that “the subband 1d-02 is used for eMBB data transmission, the subband 1d-04 is used for URLLC data transmission, and the subband 1d-06 is used for mMTC data transmission.” APPLE-1005, 16:24-36, APPLE-1006, [0168]. As discussed with

respect to [5a], the above division into **three separate subbands** (the claimed “**Q subbands**” with $Q=3$, a positive integer) is indicated to a UE or terminal by “**higher signaling**,” and as such, *Yeo-TS36* renders obvious that “the **second signaling** is used for determining **Q subbands**.” APPLE-1003, 106.

[5c]: “the first subband belongs to one of the Q subbands;”

Yeo-TS36 renders obvious [5c]. As discussed for limitation [1g], a subband for a specific service – such as the subband 1d-06 for mMTC—as described in *Yeo*—constitutes or at least renders obvious the claimed “first subband,” and the **subband 1d-06** is one of the **three subbands**. APPLE-1005, FIG. 1D, APPLE-1006, FIG. 1d; APPLE-1003, 107.

[5d]: “any one of the Q subbands comprises a positive integer number of consecutive subcarriers; and”

Yeo-TS36 renders obvious [5d]. As discussed for limitation [1h], *Yeo* describes that the UE monitors the MPDCCH—i.e., the PDCCH for mMTC device/services—on a mMTC subband comprising consecutive subcarriers. APPLE-1005, FIG. 1A, 12:35-41; APPLE-1006, FIG. 1a, [0060]; APPLE-1003, 97. As such, A POSITA would have understood that any one of the service-specific subbands (the claimed “Q subbands”)—“the subband 1d-02...for eMBB data transmission, the subband 1d-04... for URLLC data transmission, and the

subband 1d-06...for mMTC data transmission”— comprises consecutive subcarriers. APPLE-1005, 16:24-36, APPLE-1006, [0168] APPLE-1003, 108.

[5e]: “the feature ID of the monitor of the first signaling is used for determining the first subband in the Q subbands.”

Yeo-TS36 renders obvious [5e]. The phrase “**the** feature ID” lacks antecedent basis, and as best understood, is intended to refer to “**a** feature ID of the monitor.” As discussed for limitation [1a], *Yeo* describes a UE for “monitoring a first signaling,” and hence, a feature identifier associated with the UE in *Yeo* would constitute or at least render obvious “the feature ID of the monitor of the first signaling.” As discussed above in **Section V.2** *supra*, *Yeo* describes various types of UEs that are served by the wireless network, including UE type that supports massive machine type communication (mMTC), UE type that supports MIMO, UE type that supports enhanced mobile broadband (eMBB), and UE type that supports ultra-reliable and low-latency Communications (URLLC). APPLE-1005, 2:13-23; 10:10-14; APPLE-1006, [0004], [0027]. It was well known to a POSITA as of the Critical Date that a feature ID (i.e., UE categoryDL number) of a UE can be used to determine downlink frequency subbands supported by a UE, and as such, the foregoing feature is rendered obvious by the *Yeo-TS36* combination. APPLE-1003, 109. For example, the 3GPP Technical Specification *3GPP TS 36.306 V14.1.0 (2016-12)* enumerates various “UE radio access capability

parameters,” which specifically includes the UE categoryDL number and and ue-CategoryUL number to define downlink/uplink capability respectively. A POSITA would have understood (*see* APPLE-1026, page 5: “DL Category 0 / UL category 0 was specifically added designed for support of MTC applications. Table 2-2 shows the basic capabilities in downlink and uplink, respectively”). A POSITA would have readily understood the *ue-CategoryDL* number to be a “feature ID” of a UE which would allow the UE to identify the subband 1d-06 for mMTC—as described in *Yeo*. APPLE-1003, 109.

As another example, the 3GPP Technical Specification *3GPP TS 36.306 V14.1.0 (2016-12)* enumerates various “UE radio access capability parameters,” which specifically includes the parameter “*supportedBandList-r13*”- defining which “radio frequency bands...are supported by the UE,” and noting that the “field is only applicable for UEs of any *ue-Category-NB*” APPLE-1025, p.35; APPLE-1003, 110. A POSITA would have readily understood *ue-Category-NB* to be a “feature ID” of a UE, which would allow the UE to use a parameter such as *supportedBandList-r13* to determine frequency bands or subbands supported by the UE. APPLE-1003, 110.

4. *Claim 6*

[6pre]: “A method in a base station for paging, comprising:”

Yeo-TS36 renders obvious [6pre]. As discussed for claim [1pre], *Yeo* describes a method in a UE for paging, to monitor a PDCCH in a paging occasion. *Yeo* also describes the paging process from the perspective of a base station. APPLE-1005, FIG. 3L; APPLE-1006, FIG. 5k; APPLE-1003, 81, 111.

[6a]: “transmitting a first signaling in a positive integer number of time intervals of X time intervals; and”

Yeo-TS36 renders obvious [6a]. As discussed for claim [1a], *Yeo* describes monitoring a PDCCH configured as P-RNTI and paging DCI (which constitute or at least render obvious claimed “first signaling”) in paging occasions - the time intervals for which correspond to the claimed X time intervals. *Yeo* also describes transmitting the PDCCH configured as P-RNTI from a base station eNB. APPLE-1005, FIG. 3J (annotated below); APPLE-1006, FIG. 5i; APPLE-1003, 82-84, 112.

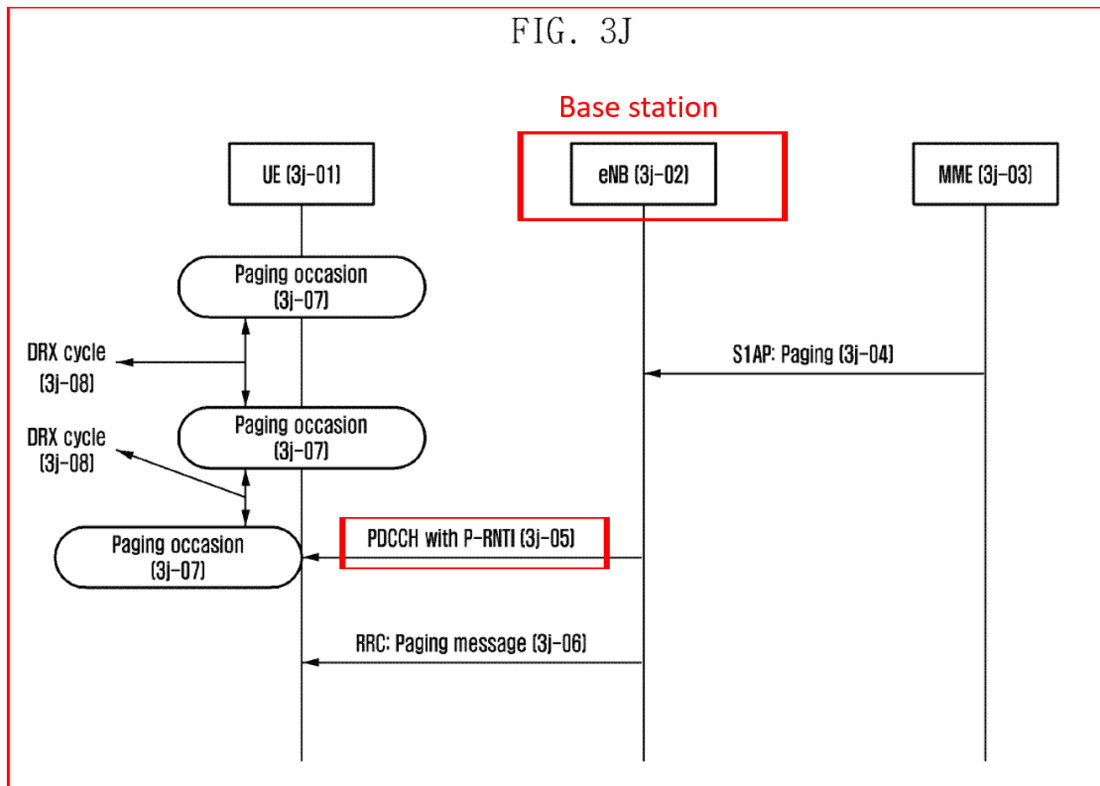

[6b]: “transmitting a first radio signal;”

Yeo-TS36 renders obvious [6b]. As discussed for limitation [1b], *Yeo* describes that “[t]he paging message is transmitted through the PDSCH, and scheduling information on the PDSCH can be acquired from the PDCCH configured as P-RNTI.” APPLE-1005, 53:48-51; APPLE-1006, [0013]. A POSITA would have understood that the PDSCH is a radio signal, and as such, *Yeo-TS36* renders obvious the above limitation. APPLE-1003, 85, 113.

Remaining limitations of claim 6

Yeo-TS36 renders obvious the remaining limitations of claim 6. The remaining limitations of claim 6 are substantially similar to limitations [1c]-[1i] of claim 1, and thus are respectively rendered obvious by *Yeo-TS36* for the same reasons discussed above for limitations [1c]-[1i]. APPLE-1003, 86-101, 114.

5. *Claim 9*

Yeo-TS36 renders obvious claim 9. As noted above, *Yeo-TS36* renders obvious claim 6. The remaining limitations of claim 9 are substantially similar to claim 4, and thus are rendered obvious by *Yeo-TS36* for the reasons discussed for claim 4. APPLE-1003, 102-104, 115.

6. *Claim 10*

The *Yeo-TS36* combination renders obvious claim 10. As noted above, the combination renders obvious claim 6. The remaining limitations of claim 10 are substantially similar to claim 5, and thus are rendered obvious by the combination for the reasons discussed for claim 5. APPLE-1003, 105-110, 116.

7. *Claims 11, 14, and 15*

Yeo-TS36 renders obvious each of these claims. Independent claim 11 is substantially similar to claim 1, except it is an apparatus claim directed to “[a] UE

for paging,” and requires (1) “a first receiver module” to monitor a first radio signaling in X time intervals, and (2) “a second receiver module” to receive a first radio signal. *Yeo-TS36* renders obvious these apparatus-related limitations. APPLE-1003, 117.

“A UE for paging”

Yeo describes a UE executing a paging process. APPLE-1005, FIG. 3J; APPLE-1006, FIG. 5i; APPLE-1003, 118.

“a first receiver module” and “a second receiver module”

As discussed in **Section III.C**, the structure attributed by the ’767 Patent to each of the “first receiver module” and the “second receiver module” is “the transmitter/receiver 456 (including the antenna 460), the receiving processor 452 and the controller/processor 490 shown in FIG. 4.” APPLE-1001, 20:59-67. *Yeo* discloses the structure for the claimed receiver modules at least as much as the ’767 Patent discloses. For example, *Yeo*’s “block diagram of a structure of a terminal transceiver” renders obvious the claimed “first receiver module” and “second receiver module.” APPLE-1005, FIG. 3Q; APPLE-1006, FIG. 5m; APPLE-1003, 119. *Yeo* specifically notes the a “terminal may include user equipment (UE), a mobile station (MS), a cellular phone, a smart phone, a

computer, or a multimedia system performing a communication function.”

APPLE-1005, 18:52-55; APPLE-1006, [0083]. *Yeo* further describes that a “terminal receiver...and the terminal transmitter...may collectively be referred to as a transceiver,” and “the transceiver may include...an RF receiver” that “may receive a signal through a radio channel and output the received signal to the terminal processor.” From at least the foregoing description in *Yeo*, a POSITA would have understood that the structure espoused for each of the “first receiver module” and the “second receiver module” is described by *Yeo*. APPLE-1003, 119.

Insofar the '767 Patent points to the same structure for each of the “first receiver module” and the “second receiver module,” each/both would have been obvious to a POSITA based on the disclosure of *Yeo*. Specifically, *Yeo* describes transmitting and receiving DCI information by “spatial multiplexing using...multiple antenna,” APPLE-1005, 13:11-24; APPLE-1006, [0144]; APPLE-1003, 120. A POSITA would have reasonably envisaged or gleaned as obvious from this that multiple receiver circuits are connected, respectively, to multiple antennas, with each receiver circuit being used to process the signal received from its respective antenna. *Id.* Such parallel processing of the antenna signals was well-known to a POSITA as of the Critical Date, (*see* APPLE-1021,

Fig. 2 (annotated below - showing one receiver at each antenna), and would allow *Yeo's* terminal receiver to simultaneously decode and demodulate the signals received from multiple receive antennas, thereby improving the system speed. *Id.*, [0037]-[0038]; APPLE-1003, 120.

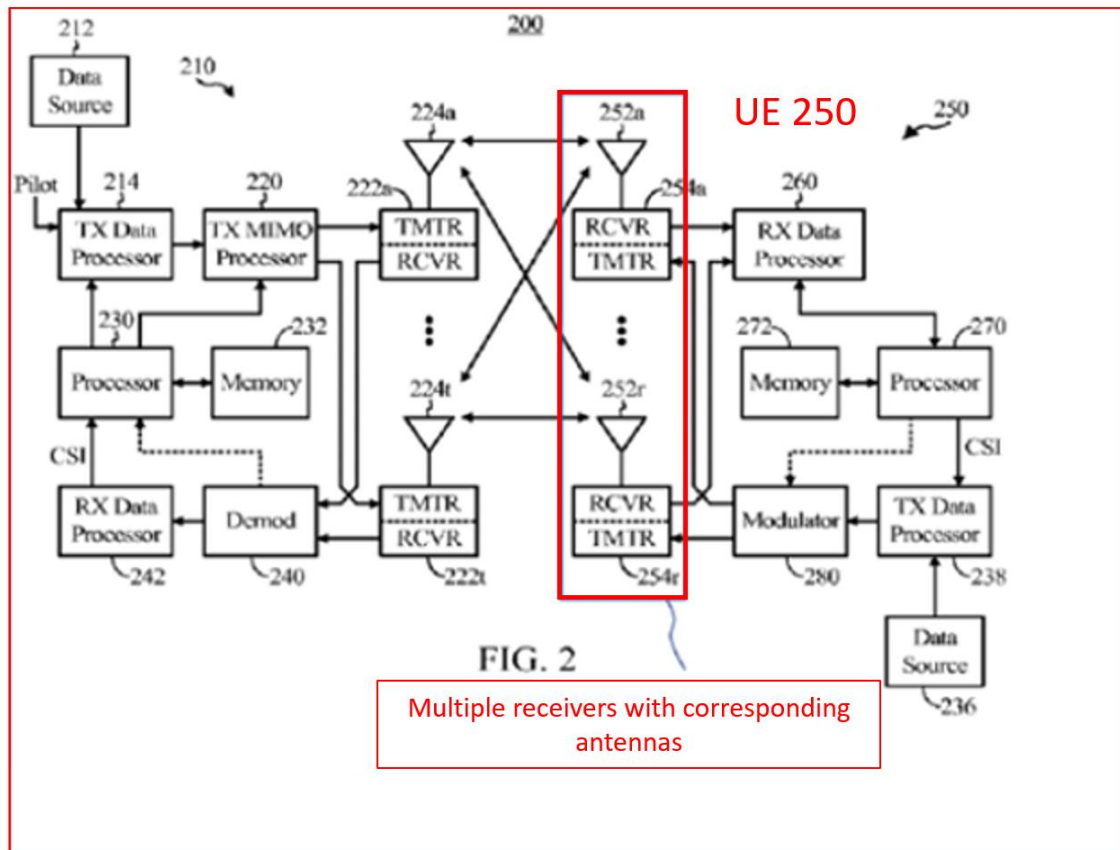

Luo, Fig. 2., Annotated.

Therefore, *Yeo-TS36* renders obvious multiple receiver modules, each including a receive antenna and an associated receiver circuit that includes a transmitter, a receiver and one or more processors. APPLE-1005, FIG. 3Q; APPLE-1006, FIG. 5m. A POSITA would have reasonably expected to

succeed in providing two receiver modules, each receiving the claimed “first signaling” and “first radio signal” respectively, in *Yeo*’s UE because multiple receiver modules receiving these signals were conventional and routine in the MIMO antennas described in *Yeo*, APPLE-1005, 1:32-40; APPLE-1006, [0002]; APPLE-1021, Fig. 2. As such, the combination represents nothing more than known components operating according to their ordinary and expected functions to yield predictable results (receiving signals). APPLE-1003, 121.

Even if Petitioner’s proposed construction is not adopted and plain and ordinary meaning is instead applied, the above limitations are rendered obvious by *Yeo*. A POSITA would understand the plain and ordinary meaning for this term to mean or at least include a wireless receiver such as in a UE. APPLE-1003, 122. As explained above, *Yeo* describes one or more instances of such a wireless receiver. Notably, Patent Owner’s infringement contentions do not mention the term “module,” let alone a “first receiver module” and a “second receiver module.” Patent Owner notes instead with respect to claim 11 that “[t]he Accused Products monitor a first signaling (e.g., Paging DCI) in X time intervals (e.g., PDCCH monitoring occasions).” APPLE-1023, ¶¶80-81. Under the position that Patent Owner advances in the litigation, the foregoing features are rendered obvious by

Yeo-TS36 at least because of *Yeo*'s description of a terminal/UE. APPLE-1005, 18:52-55; APPLE-1006, [0083]. APPLE-1003, 122.

Remaining limitations of claims 11, 14, and 15

Yeo-TS36 renders obvious each of these claims. Given the similarity between claims 1 and 11, the remaining features of claim 11 are respectively rendered obvious for the same reasons discussed above for the corresponding features of claim 1. APPLE-1003, 59, 81-101, 123.

Similarly, claims 4 and 14, and 5 and 15, are respectively similar to one another and are obvious for the same reasons discussed above with respect to claims 4 and 5, respectively. *Id.*, 59, 102-110, 124.

8. *Claims 16, 19, and 20*

Yeo-TS36 renders obvious each of these claims. Independent claim 16 is substantially similar to claim 6, except it is an apparatus claim directed to a base station for paging, and requires (1) "a first transmitter module" to transmit a first signaling in a positive integer number of time intervals of X time intervals, and (2) "a second transmitter module" to transmit a first radio signal. APPLE-1003, 61. *Yeo-TS36* renders obvious these apparatus-related limitations. *Id.*, 125.

“A base station for paging”

Yeo describes a base station executing a paging process. APPLE-1005, FIG. 3J (*see* annotated version above); APPLE-1006, FIG. 5i; APPLE-1003, 126.

“a first transmitter module” and “a second transmitter module”

As discussed in **Section III.C**, the structure attributed by the '767 Patent to each of the “first transmitter module” and the “second transmitter module” is “to transmit,” which it describes as performed by the following structure: “the transmitter/receiver 416 (including the antenna 420), the transmitting processor 415 and the controller/processor 440 shown in FIG. 4.” APPLE-1001, 21:51-58. *Yeo* discloses the structure for the claimed transmitter modules at least as much as the '767 Patent discloses. For example, *Yeo*'s “block diagram of a structure of a base station transceiver” renders obvious the above limitations. APPLE-1005, FIG. 3R; APPLE-1006, FIG. 5n; APPLE-1003, 127. *Yeo* further describes that a “base station receiver...and the base station transmitter...are collectively referred to as a transceiver,” and that “the transceiver may include...an RF transmitter” that may “transmit the signal output from the base station processor.” From at least the foregoing description in *Yeo*, a POSITA would have understood that the structure

espoused for each of the “first transmitter module” and the “second transmitter module” is described by *Yeo*. *Id.*

Inasmuch as the '767 Patent points to the same structure for each of the “first transmitter module” and the “second transmitter module,” each/both would have been obvious to a POSITA based on the combination of *Yeo-TS36*. Specifically, *Yeo* describes transmitting and receiving DCI information by “spatial multiplexing using...multiple antenna,” APPLE-1005, 13:11-24; APPLE-1006, [0144]; APPLE-1003, 128. A POSITA would have reasonably envisaged or gleaned as obvious from this that multiple transmitter circuits are connected, respectively, to multiple antennas, with each transmitter circuit being used for transmitting signals through the respective transmit antenna. *Id.* Such parallel processing of the antenna signals was well-known to a POSITA as of the Critical Date (*see* APPLE-1021, Fig. 2 (annotated below – showing one transmitter for each antenna)), and would allow *Yeo*'s base station to simultaneously transmit signals through multiple transmit antennas, thereby implementing a MIMO system. *Id.*, [0035]-[0036]; APPLE-1003, 128.

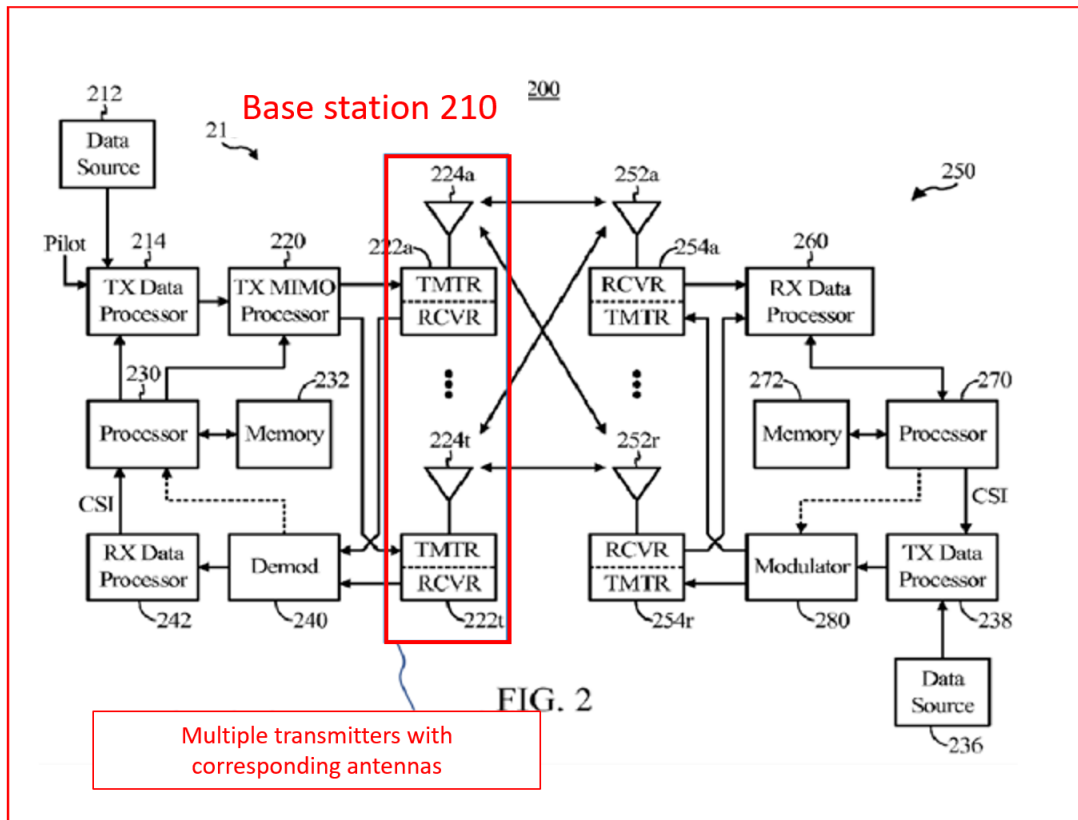

Luo, Fig. 2., Annotated

Therefore, *Yeo-TS36* renders obvious multiple transmitter modules, each including a transmit antenna and an associated transmitter circuit. A POSITA would have reasonably expected to succeed in providing two transmitter modules, each transmitting the claimed “first signaling” and “first radio signal” respectively, in *Yeo*’s base station because multiple transmitters transmitting these signals were conventional and routine in the MIMO antennas described in *Yeo*, APPLE-1005, 1:32-40; APPLE-1006, [0002]; APPLE-1021, Fig. 2. As such, the combination represents nothing more than known components

operating according to their ordinary and expected functions to yield predictable results (receiving signals). APPLE-1003, 129.

Even if Petitioner's proposed construction is not adopted and plain and ordinary meaning is instead applied, the above limitations are rendered obvious by *Yeo-TS36*. A POSITA would understand the plain and ordinary meaning for this term to mean or at least include a wireless transmitter such as in a base station. APPLE-1003, 130. As described above, *Yeo* describes one or more instances of such a wireless transmitter.

Remaining limitations of claims 16, 19, and 20

Given the similarity between claims 6 and 16, the remaining features of claim 16 are respectively rendered obvious for the same reasons discussed above for the corresponding features of claim 6. APPLE-1003, 61, 112-114, 131.

Similarly, claims 9 and 19, and 10 and 20, are respectively similar to one another and are obvious for the same reasons discussed with respect to the corresponding claims. APPLE-1003, 61, 115-116, 132.

B. [GROUND 2] Claims 2, 3, 7, 8, 12, 13, 17, and 18 Are Obvious over *Yeo*, *TS36*, and *Mallick*

1. Overview of *Mallick*

Similar to *Yeo's* description of mMTC for coverage enhancement (see APPLE-1005, 41:61-67; APPLE-1006, [0309]), *Mallick* discusses using coverage extension (CE) to page MTC devices (APPLE-1008, Abstract, [0140]-[0141], [0145]). *Mallick* also explains that “[c]overage [e]xtension” is another term for coverage enhancement. *Id.*, [0060]. *Mallick* recognizes that CE requires repeated transmission of paging control information and/or increased power, imposing a heavier burden on the base station than normal coverage. *Id.*, [0072], [0078], [0151]. To alleviate this problem, instead of indiscriminately applying CE to all UEs in a cell and at all the possible paging occasions, *Mallick* proposes limiting CE to only a selected group of UEs at a subset of the paging occasions. *Id.*, [0160]. APPLE-1003, 133.

Specifically, the UEs in a cell covered by a base station are divided into UEs that experience bad radio conditions and thus require CE (“CE-UEs”), and normal UEs that do not require CE (“non-CE-UE[s]”). APPLE-1008, [0075], [0135]. As shown in Figure 7, the base station (i.e., eNB) may page all the UEs in its cell (including the CE-UEs and non-CE-UEs) at **UE-specific paging possibilities without using the CE technique**. *Id.*, [0146], [0159], Fig. 7. Additionally, the eNB also pages the CE-UEs at **CE-specific paging possibilities by using the CE technique**. *Id.* The term “paging possibility”

refers to the combination of a paging frame (i.e., a radio frame) and a paging occasion (i.e., one or more subframes within the paging frame). *Id.*, [0024], [0072], [0148], [0161]. APPLE-1003, 134.

The **UE-specific paging possibilities** are determined based on the ordinary UE identifiers (UE-specific IDs), in the same way defined in the 4G/LTE standards, and thus are specific to the UEs. APPLE-1008, [0025]-[0029], [0148]. The **CE-specific paging possibilities** may be determined based on a CE-specific ID common to a group of CE-UEs, and thus are the same for these CE-UEs. *Id.*, [0079], [0093], [0101], [0107], [0148], [0169]-[0170], claim 5. APPLE-1003, 135.

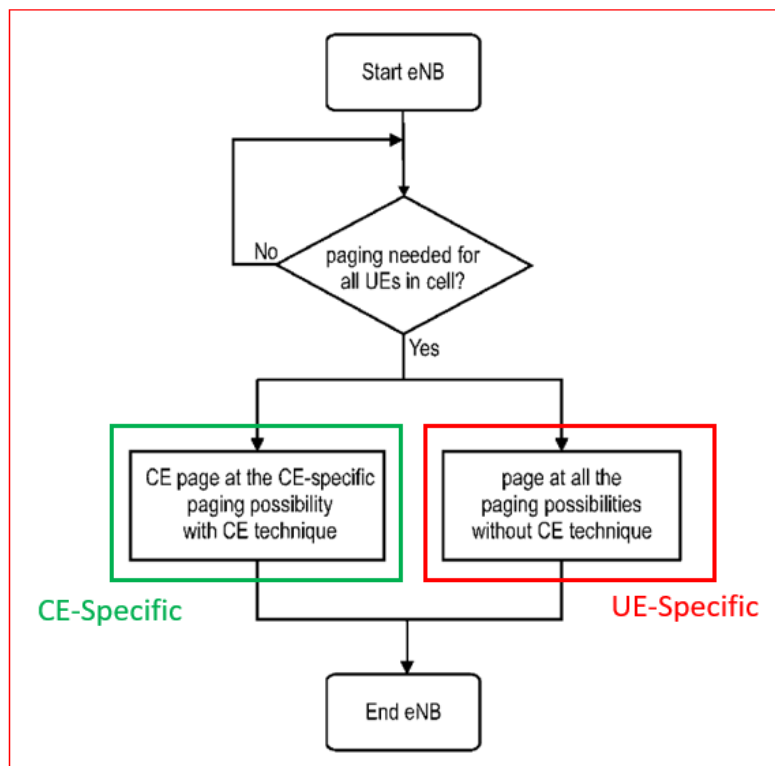

Mallick., Fig. 7., Annotated

Figure 5 shows two CE-specific UEs monitoring the normal paging PDCCHs at different **UE-specific paging possibilities**, and monitoring the CE paging PDCCHs at the same **CE-specific paging possibilities**. APPLE-1008, [0157]-[0158]. Meanwhile, non-CE-UEs (not shown) only monitor their respective **UE-specific paging possibilities**. *Id.*, [0148], [0154]. APPLE-1003, 136.

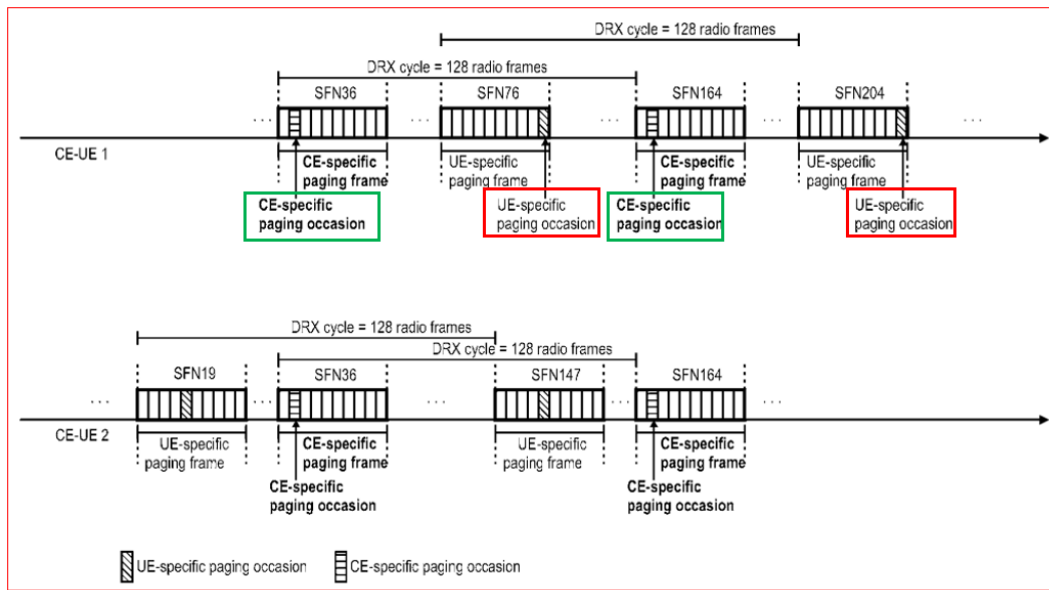

Mallick, Fig. 5., Annotated

By limiting the CE to the **CE-specific paging possibilities**, the downlink resources can be saved and the burden on the base station can be reduced. APPLE-1008, [0078], [0160], [0174]-[0175]. APPLE-1003, 137.

Mallick is analogous art to the '767 patent because *Mallick*, like the '767 patent, discloses methods for a UE to monitor paging scheduling information for a number of times. Compare APPLE-1008, [0001], [0139], [0152], with APPLE-1001, Abstract, 2:27-39; APPLE-1003, 138.

2. Combining *Yeo-TS36* with *Mallick*

A POSITA would have been motivated to combine *Yeo-TS36* with *Mallick*'s improved CE paging procedure, including its description about how to determine the UE-specific paging possibilities and CE-specific paging possibilities. APPLE-1003, 139. *Mallick*, *Yeo*, and *TS36* are all related to paging/DRX procedure in MTC UEs that are compliant with 3GPP 4G/LTE or 5G/NR standards. APPLE-1005, 53:8-20; APPLE-1006, [0455]; APPLE-1009, p.39-40; APPLE-1008, Abstract, [0143], [0145]; APPLE-1001, 1:45-47, 5:1-3. *Mallick* describes that limiting the CE to CE-UEs and the CE-specific paging possibilities can save downlink resources and reduce the burden on the base station. APPLE-1008, [0078], [0160], [0174]-[0175]. Moreover, for a higher granularity, *Mallick*'s CE-specific IDs and CE-specific paging possibilities can be further classified according to the CE levels, such that a CE-UE can skip monitoring the CE-specific paging possibilities not associated with its CE level, thereby reducing the CE-UE's power consumption. *Id.*, [0169]-[0172].

And *Yeo* describes coverage enhancement of UEs specifically for mMTC in 5G. APPLE-1005, 41:61-67, APPLE-1006, [0309]. Thus, a POSITA would combine *Mallick*'s advantageous CE design to improve the implementations contemplated by the *Yeo-TS36* combination. APPLE-1003, 139. A POSITA would have a reasonable expectation of success in combining *Yeo-TS36* with *Mallick* (the combination referred herein as "*Yeo-TS36-Mallick*") because it only requires combining elements according to known methods. APPLE-1003, 139. Indeed, *Mallick*'s equations " $\text{SFN mod } T = (T \text{ div } N) * (\text{UE_ID mod } N)$ " to determine the paging frame number SFN, and " $i_s = \text{floor}(\text{UE_ID}/N) \text{ mod } N_s$ " to determine the paging occasion index i_s are identical to the corresponding equations described in *TS36*. A POSITA would have a reasonable expectation of success in combining *Mallick* with the *Yeo-TS36* combination at least because *Mallick* explicitly refers to an earlier version of the *TS36* as the specification relied on for determining paging occasions. APPLE-1008, [0025]-[0028]; APPLE-1009, p.39-40. A POSITA would also have understood that the combination would lead to predictable results by reducing the burden on a base station and/or power consumption in certain UEs—as described by *Mallick*—in the paging/DRX procedure in MTC UEs, as described by the *Yeo-TS36* combination. APPLE-1003, 139.

1. *Claim 2*

[2a]: “The method according to claim 1, wherein any one of the **X time intervals** belongs to a **first time window** in time domain;”

Yeo-TS36-Mallick renders obvious [2a]. As discussed with respect to [1a], *Yeo* describes each **paging occasion** “as a subframe in which the PDCCH [is] configured as the P-RNTI,” and a paging frame as “one radio frame including **one or more POs**.” APPLE-1005, 53:14-17; APPLE-1006, [0455]. *Yeo* also describes that “a radio frame...is a time domain unit which includes 10 subframes.” APPLE-1005, 30:11-12; APPLE-1006, [0372]. As such, for LTE (having a subframe duration of 1 ms)—as shown in FIG. 2E of *Yeo* (annotated below)—the radio frame length is 10 ms. The **10 ms time window** corresponding to an LTE frame constitutes or at least renders obvious the claimed “**first time window**.” APPLE-1005, FIG. 2E; APPLE-1006, FIG. 3e; APPLE-1003, 140.

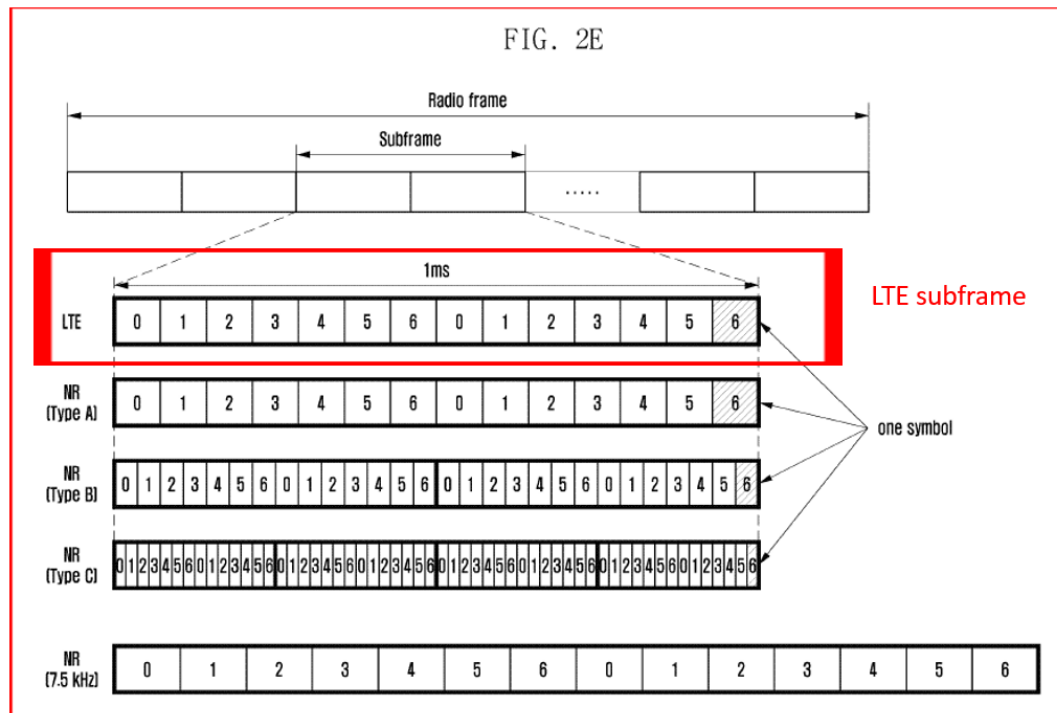

[2b]: “the time length of the first time window is predefined;”

Yeo-TS36-Mallick renders obvious [2b]. As noted with reference to limitation [2a], the duration of an LTE frame is 10 ms – which is a predefined time window. Thus, *Yeo* describes that the time length of the first time window is predefined. APPLE-1003, 141.

[2c]: “the first time window is divided into Y time intervals;”

Yeo-TS36-Mallick renders obvious [2c]. *Yeo* describes that the 10 ms time window is divided into multiple time intervals and the number of time intervals depends on the subframe type. APPLE-1003, 142. For example, in a frame structure Type A, the subframe size is 1 ms, and the number of time intervals is

$Y=10$; in a frame structure Type B, the subframe size is 0.5 ms, and the number of time intervals is $Y=20$; in a frame structure Type C, the subframe size is 0.25 ms, and the number of time intervals is $Y=40$. APPLE-1005, 30:67-31:15; APPLE-1006, [0224]; APPLE-1003, 142.

[2d]: “the X time intervals are X time intervals of the Y time intervals, Y being a positive integer not smaller than X ;”

Yeo-TS36-Mallick renders obvious [2d]. As discussed with respect to [1a], *Yeo* describes each paging occasion “as a subframe in which the PDCCH [is] configured as the P-RNTI,” and a paging frame as “one radio frame including one or more POs.” APPLE-1005, 53:14-17; APPLE-1006, [0455]. *Yeo* further describes that the duration of a subframe is 1 ms, 0.5 ms, or 0.25 ms, depending on whether the NR frame structure is of Type A, Type B, or Type C, respectively – resulting in the following parameters within the 10 ms “first time window”:

NR frame type	Subframe duration	No. of subframes or Y time intervals per 10 ms time window	No. of frames or paging occasions (X) per 10 ms time window
Type A	1 ms	10	1
Type B	0.5 ms	20	2

Type C	0.25	40	4
--------	------	----	---

APPLE-1005, 30:67-31:15; APPLE-1006, [0224]; APPLE-1003, 143.

Because for each frame type, the number of paging occasions X is one of the subframes corresponding to the Y time intervals, *Yeo* describes the foregoing feature. APPLE-1003, 143.

[2e]: “the subcarrier spacing of subcarriers included in the first subband is used for determining Y ; and”

Yeo-TS36-Mallick renders obvious [2e]. As shown with respect to limitation [2d], the number of Y time intervals within the 10 ms “first time window” depends on the subframe duration. APPLE-1003, 144. *Yeo* further describes with respect to FIGs. 2B, 2C, and 2D (reproduced below with annotations) that the duration of the subframe in turn depends on the subcarrier spacing. Specifically, *Yeo* describes that “in a frame structure type A, subcarrier spacing is 15 kHz, a subframe of 1 ms includes 14 symbols”; “in a frame structure type B, the subcarrier spacing is 30 kHz, a subframe of 0.5 ms includes 14 symbols”; and “in a frame structure type C, subcarrier spacing is 60 kHz, a subframe of 0.25 ms includes 14 symbols.”

APPLE-1005, 30:67-31:15; APPLE-1006, [0224]; APPLE-1003, 144.

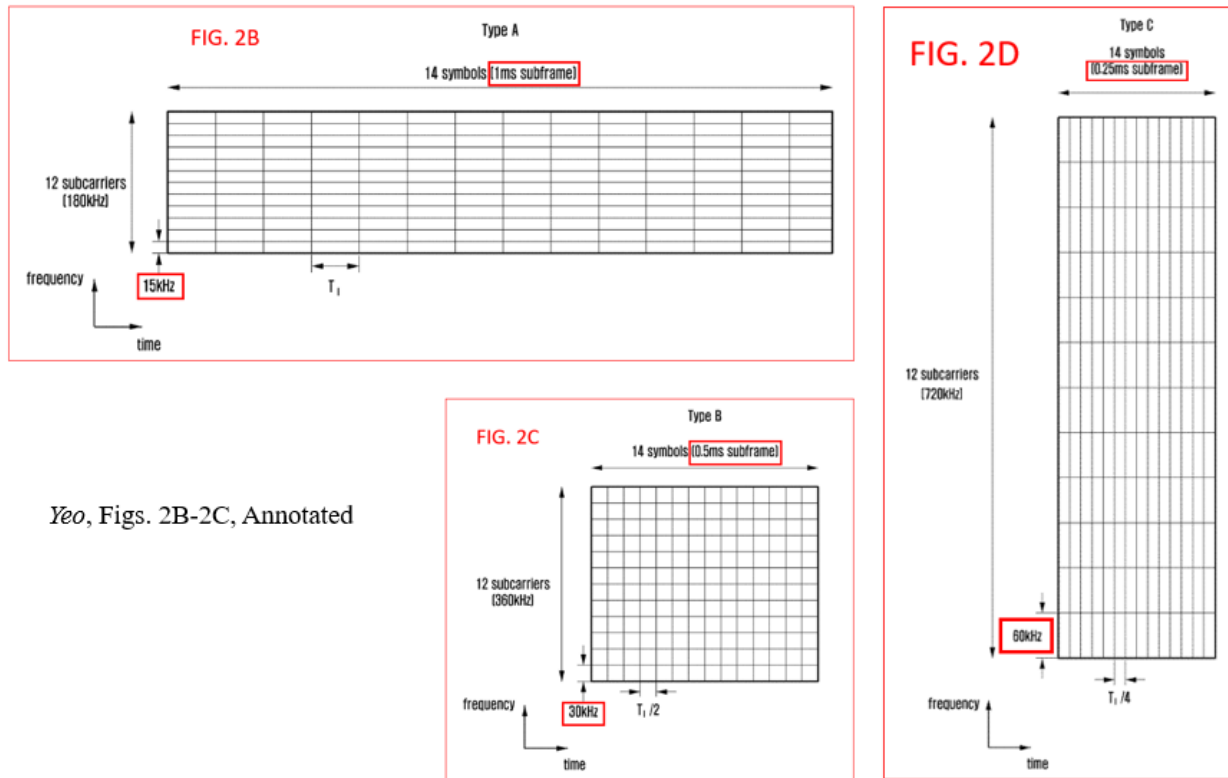

Yeo, Figs. 2B-2C, Annotated

For at least the foregoing reasons, Yeo describes that the Y intervals are determined based on the subcarrier spacing of subcarriers included in the first subband. APPLE-1003, 144.

[2f]: “a feature ID of a monitor of the first signaling is used for determining the X time intervals in the Y time intervals.”

Yeo-TS36-Mallick renders obvious [2f]. APPLE-1003, 145. As discussed for limitation [1a], Yeo’s “PDCCH configured as P-RNTI” constitutes or at least renders obvious the claimed “first signaling.” APPLE-1005, 14:5-8, APPLE-1006, [0055]; APPLE-1003, 145. Yeo further defines the “subframe in which the PDCCH [is] configured as the P-RNTI,” as a

paging occasion and a paging frame as “one radio frame including **one or more POs**,” APPLE-1005, 53:14-17; APPLE-1006, [0455]. However, while *Yeo* (i) describes the exact same equation for determining a PF as *TS36*, and (ii) notes that a PF includes “one or more POs,” *Yeo* does not specifically describe how those “one or more POs” are determined by a UE. Both *TS36* and *Mallick* fill this gap by describing that the index “*i*_s pointing to PO” is given by the equation “ $i_s = \text{floor}(\text{UE_ID}/N) \bmod N_s$.” Because the UE monitors the PDCCH, and a POSITA would readily recognize that the UE_ID constitutes or at least renders obvious the “feature ID” of the UE that is used for determining paging occasions, both *TS36* and *Mallick* describe the claimed “**feature ID** of a monitor of the **first signaling**,” and that it “is used for determining the **X time intervals**.” APPLE-1009, p.39-40; APPLE-1008, [0027], [0170]. A POSITA would have a reasonable expectation of success in combining *Yeo* and *TS36/Mallick* at least because a POSITA would understand that the combination leads to the predictable result of determining the UE-specific POs within the PF of *Yeo*. APPLE-1003, 145.

In addition, *Mallick* describes **multiple paging occasions** for an UE within a predefined time window. APPLE-1003, 146. For example, *Mallick* describes (with reference to FIG. 5, reproduced below with annotations) that “CE-UE1 monitors a UE-specific paging possibility at radio frame number 76

and number 204...etc., respectively at subframe 9...and that CE-UE2 monitors a UE-specific paging possibility at radio frame number 19 and 147...etc., respectively at subframe 4.” APPLE-1008, [0157]. *Mallick* also clarifies that “the term paging possibility [refers] to the combination of the paging frame and paging subframe,” and is determined as a function of the UE_ID. APPLE-1008, [0024]-[0027]. APPLE-1003, 146.

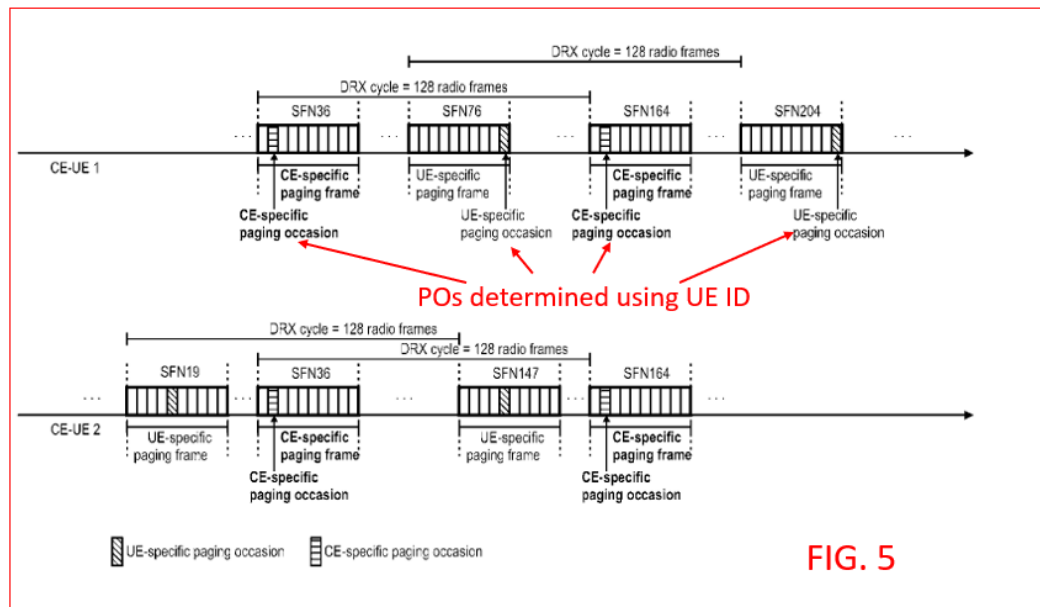

As shown with respect to limitation [2d], the number of subframes within a given time window constitutes or at least renders obvious the Y time intervals, and the *Yeo-TS36-Mallick* renders obvious determining the **paging occasions** within the **Y time intervals** based on the UE_ID. Specifically, Because *Yeo* describes coverage enhancement of UEs specifically for mMTC in 5G (APPLE-1005, 41:61-67; APPLE-1006, [0309]), a POSITA would have

been motivated to combine *Yeo-TS36* with *Mallick*'s improved CE paging procedure, including its description about how to determine the **UE-specific paging possibilities** and **CE-specific paging possibilities**. APPLE-1003, 147. , A POSITA would have had a reasonable expectation of success in combining *Mallick* with the *Yeo-TS36* combination at least because *Mallick* explicitly refers to an earlier version of the *TS36* as the specification relied on for determining paging occasions, (APPLE-1008, [0025]-[0028]; APPLE-1009, p.39-40), and the combination would lead to predictable results by reducing the burden on a base station and/or power consumption in certain UEs—as described by *Mallick*—in the paging/DRX procedure in MTC UEs, as described by the *Yeo-TS36* combination. As such, the limitation [2f] is rendered obvious by *Yeo-TS36-Mallick*. APPLE-1003, 147.

2. *Claim 3*

[3a]: “The method according to claim 2, wherein the **first time window belongs to one of **Z time windows**, Z being an integer greater than 1;”**

Yeo-TS36-Mallick renders obvious claim 3. As discussed for limitation [2a], *Yeo-TS36-Mallick* renders obvious that the **paging occasions** are subframes within a **10 ms time window**. *Mallick* further describes that a **DRX cycle** contains an integer number (e.g., 32, 64, 128 or 256) of radio frames. APPLE-1008, [0038], Fig. 5 (reproduced below with annotations).

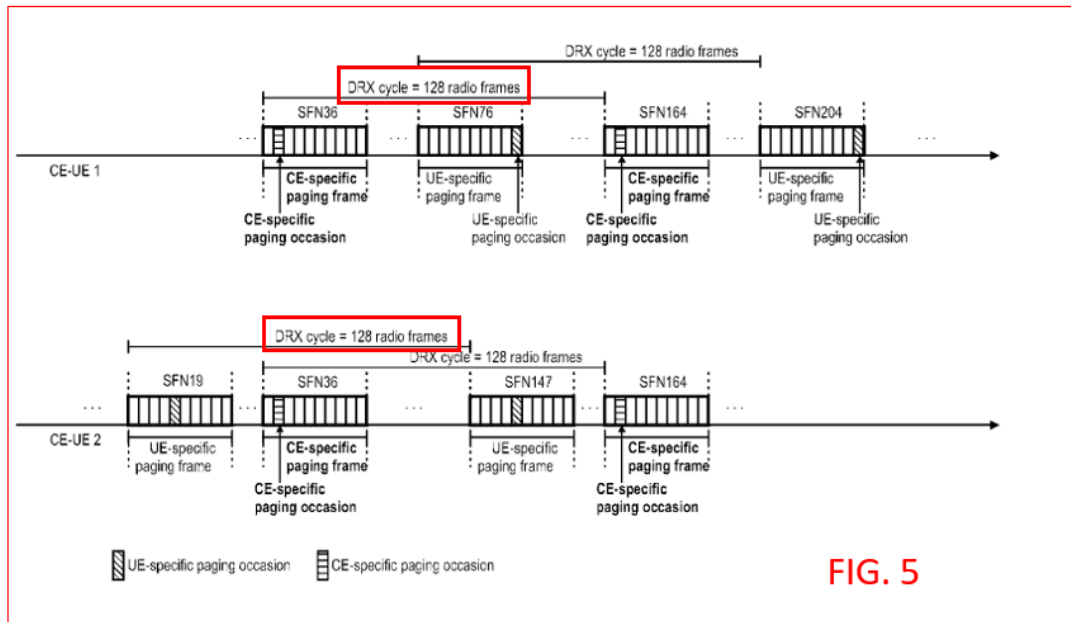

Mallick, FIG. 5, Annotated

APPLE-1003, 148.

Taking the example of the shortest default paging cycle of 32 radio frames, and the NR Type A frame described in *Yeo* (Figure 2E, above), the duration of the paging cycle is $32 * 10 \text{ ms} = 320 \text{ ms}$ - a time duration that includes 32 time windows each of duration 10 ms. The 32 time windows (each of duration 10 ms) in the paging cycle constitute or at least render obvious the “Z time windows,” and the “first time window” of 10 ms is one of the 32 time windows. APPLE-1003, 149. In the examples of 64, 128, or 256 frame paging cycles for the NR Type A frame, the number of Z time windows is 64, 128, or 256, respectively, and the “first time window” of 10 ms is one of

the corresponding number of time windows. As such, *Yeo-TS36-Mallick* renders obvious [3a]. APPLE-1003, 149.

[3b]: “Z is predefined, or Z is configurable;”

Yeo-TS36-Mallick renders obvious [3b]. *Yeo* describes—with reference to FIG. 2E—multiple frame structures both for LTE as well as for NR.

APPLE-1005, FIG. 2E, APPLE-1006, FIG. 3e; APPLE-1003, 150. *Yeo* also describes that in LTE systems “a length of the subframe is 1.0 ms,” which does not change. APPLE-1005, 30:10-11; APPLE-1006, [0372]; APPLE-

1003, 150. *Yeo* also describes that in 5G “the frame structure type is generalized, the subcarrier spacing, the CP length, and the subframe length that are the essential parameter sets have an integer multiple relationship with each other for each type, such that high scalability may be provided.”

APPLE-1005, 31:20-24; APPLE-1006, [0227]. As such, *Yeo* describes that the frame structures are either predefined (LTE) or configurable (NR Types A, B, C). APPLE-1003, 150.

Further, as described with reference to limitation [3a], the subframe structure directly affects the number of time windows Z in a paging cycle of a given length. Because *Yeo* describes that the frame structures are either predefined or

configurable, *Yeo-TS36* therefore renders obvious predefined or configurable number of time windows Z. APPLE-1003, 151.

[3c]: “any two of the Z time windows have an equal time length; and”

Yeo-TS36-Mallick renders obvious [3c]. As shown with reference to the limitation [3a], taking the example of the shortest default paging cycle of 32 radio frames, and the NR Type A frame described in *Yeo* (Figure 2E, above), the duration of the paging cycle is $32 * 10 \text{ ms} = 320 \text{ ms}$ - a time duration that includes 32 time windows each of duration 10 ms. As such, *Yeo-TS36* renders obvious describes that “any two of the Z time windows have an equal time length.” APPLE-1003, 152.

[3d]: “the feature ID of the monitor of the first signaling is used for determining the first time window in the Z time windows.”

Yeo-TS36-Mallick renders obvious [3d]. As discussed for limitation [2f], both *TS36* and *Mallick* describe the claimed “feature ID of a monitor of the first signaling” by disclosing a UE ID that is used for determining a paging occasion in a paging frame. Both *TS36* and *Mallick* further describe that the same UE ID can be used to determine the paging frame itself. Compare APPLE-1008, [0025] and APPLE-1009, p.39-40 with ’767 patent,

5:15-19 (using substantially the same formula to determine “the **paging frame number (SFN)**” based on the “**UE_ID**”). Further, as discussed with respect to limitation [3a], *Mallick* further describes that a **DRX cycle** contains an integer number (e.g., 32, 64, 128 or 256) of radio frames – which a POSITA would understand to be paging frames. As such, *Yeo-TS36-Mallick* renders obvious this limitation. APPLE-1003, 153.

3. *Claims 7 and 8*

Yeo-TS36-Mallick renders obvious each of these claims. Aside from their dependency on claim 6, claims 7 and 8 are substantially similar to claims 2 and 3, respectively, and thus are rendered obvious by *Yeo-TS36-Mallick* for the reasons discussed for claims 6, 2, and 3. APPLE-1003, 62, 111-114, 140-154.

4. *Claims 12 and 13*

Yeo-TS36-Mallick renders obvious each of these claims. Aside from their dependency on claim 11, claims 12 and 13 are substantially similar to claims 2 and 3, respectively, and thus are rendered obvious by *Yeo-TS36-Mallick* for the reasons discussed for claims 11, 2, and 3. APPLE-1003, 59, 117-123, 140-153, 155.

5. Claims 17 and 18

Yeo-TS36-Mallick renders obvious each of these claims. Aside from their dependency on claim 16, claims 17 and 18 are substantially similar to claims 2 and 3, respectively, and thus are rendered obvious by *Yeo-TS36-Mallick* for the reasons discussed for claims 16, 2, and 3. APPLE-1003, 61, 125-131, 140-153, 155.

VI. DISCRETIONARY DENIAL IS NOT WARRANTED

Petitioner believes that discretionary denial is unwarranted, and yet, Petitioner intends to utilize the bifurcated briefing process contemplated by the March 26, 2025, Stewart Memorandum to rebut contentions if offered by Patent Owner to the contrary.

VII. PAYMENT OF FEES – 37 C.F.R. § 42.103

Petitioner authorizes the Patent and Trademark Office to charge any fees to Deposit Account No. 06-1050.

VIII. CONCLUSION

The cited prior art references identified in this Petition contain pertinent technological teachings (both cited and uncited), either explicitly or inherently disclosed, which were not previously considered in the manner presented herein, or relied upon on the record during original examination of the '767 patent. In sum, these references provide new, non-cumulative technological teachings which

indicate a reasonable likelihood of success as to Petitioner's assertion that the Challenged Claims of the '767 patent are not patentable pursuant to the grounds presented in this Petition. Accordingly, Petitioner respectfully requests institution of an IPR for those claims of the '767 patent for each of the grounds presented herein.

IX. MANDATORY NOTICES UNDER 37 C.F.R. § 42.8(a)(1)

A. Real Party-In-Interest Under 37 C.F.R. § 42.8(b)(1)

Apple Inc. is the petitioner and the real party-in-interest.

B. Related Matters Under 37 C.F.R. § 42.8(b)(2)

Petitioner is not aware of any disclaimers, or reexamination certificates or currently pending petitions for *inter partes* review for the '767 Patent. The '767 patent is the subject of a number of civil actions including: *Apex Beam Technologies LLC v. Apple Inc*, 6-24-cv-00223 (WDTX), filed April 29, 2024 (APPLE-1027, *see also* APPLE-1023 and APPLE-1028); *Samsung Electronics Co., Ltd. et al. v. Apex Beam Technologies LLC*, IPR2023-00598 (PTAB), filed February 28, 2023; *Apex Beam Technologies LLC v. Samsung Electronics Co., Ltd. et al*, 2-22-cv-00188 (EDTX), filed June 1, 2022; *Apex Beam Technologies LLC v. ZTE Corporation*, 2-22-cv-00031 (EDTX), filed February 1, 2022; *Apex Beam Technologies LLC v. OnePlus Technology (Shenzhen) Co., Ltd.*, 2-22-cv-00032 (EDTX), filed February 1, 2022; *Apex Beam Technologies LLC v. TCT Mobile International Limited et al*, 2-21-cv-00438 (EDTX), filed November 30, 2021.

C. Lead And Back-Up Counsel Under 37 C.F.R. § 42.8(b)(3)

Petitioner provides the following designation of counsel.

Lead Counsel	Backup counsel
W. Karl Renner, Reg. No. 41,265 Fish & Richardson P.C. 60 South Sixth Street, Suite 3200 Minneapolis, MN 55402 Tel: 202-783-5070 Fax: 877-769-7945 Email: IPR50095-0225IP1@fr.com	Indranil Sarkar, Reg. No. 79,432 Thomas Rozylowicz., Reg. No. 50,620 Fish & Richardson P.C. 60 South Sixth Street, Suite 3200 Minneapolis, MN 55402 Tel: 202-783-5070 Fax: 877-769-7945 Email: IPR50095-0225IP1@fr.com

D. Service Information

Please address all correspondence and service to the address listed above.

Petitioner consents to electronic service by email at IPR50095-0225IP1@fr.com.

Respectfully submitted,

Dated: May 1, 2025

/W. Karl Renner/
W. Karl Renner, Reg. No. 41,265
Indranil Sarkar, Reg. No. 79,432
Thomas Rozylowicz, Reg. No. 50,620
Fish & Richardson P.C.
60 South Sixth Street, Suite 3200
Minneapolis, MN 55402
T: 202-783-5070
F: 877-769-7945

(Control No. IPR2025-00894)

Attorneys for Petitioner

CERTIFICATION UNDER 37 CFR § 42.24

Under the provisions of 37 CFR § 42.24(d), the undersigned hereby certifies that the word count for the foregoing Petition for *Inter Parts* Review totals 13,057 words, which is less than the 14,000 allowed under 37 CFR § 42.24.

Dated: May 1, 2025

/W. Karl Renner/

W. Karl Renner, Reg. No. 41,265
Indranil Sarkar, Reg. No. 79,432
Thomas Rozylowicz, Reg. No. 50,620
Fish & Richardson P.C.
60 South Sixth Street, Suite 3200
Minneapolis, MN 55402
T: 202-783-5070
F: 877-769-7945

(Control No. IPR2025-00894)

Attorneys for Petitioner

CERTIFICATE OF SERVICE

Pursuant to 37 CFR §§ 42.6(e)(4)(i) *et seq.* and 42.105(b), the undersigned certifies that on May 1, 2025, a complete and entire copy of this Petition for *Inter Parts* Review, Power of Attorney, and all supporting exhibits were provided via Federal Express, to the Patent Owner by serving the correspondence address of record as follows:

Zhong Law, LLC
51 JFK Parkway
1st Floor West
Short Hills, NJ 07078
(908) 376-3104

/Crena Pacheco/

Crena Pacheco
Fish & Richardson P.C.
60 South Sixth Street, Suite 3200
Minneapolis, MN 55402
pacheco@fr.com