

UNITED STATES PATENT AND TRADEMARK OFFICE

---

BEFORE THE PATENT TRIAL AND APPEAL BOARD

---

CLEARWATER PAPER CORPORATION,  
Petitioner

v.

GRAPHIC PACKAGING INTERNATIONAL LLC,  
Patent Owner

---

Case IPR2025-00878  
U.S. Patent No. 8,637,126

---

**PETITION FOR INTER PARTES REVIEW  
OF U.S. PATENT NO. 8,637,126**

**TABLE OF CONTENTS**

I. INTRODUCTION ..... 1

II. MANDATORY NOTICES ..... 2

    A. Real Party-in-Interest ..... 2

    B. Related Matters..... 2

    C. Lead and Back-up Counsel and Service Information ..... 2

III. CERTIFICATION OF GROUNDS FOR STANDING ..... 2

IV. STATEMENT OF PRECISE RELIEF REQUESTED ..... 3

    A. Claims for Which Review Is Requested ..... 3

    B. Statutory Grounds of Challenge..... 3

V. U.S. PATENT NO. 8,637,126 ..... 5

    A. Background ..... 5

    B. Prosecution History ..... 7

        1. Degradability of the moisture protectant layers..... 8

        2. Coat weight of the moisture protectant layers. .... 9

        3. Lack of intervening layer between the moisture  
           protectant layer and the paperboard substrate..... 10

        4. Filler content in the moisture protectant layer ..... 11

    C. Petitioner’s Prior Art Undercuts the Examiner’s Reasons for  
       Allowance..... 12

    D. The Level of Ordinary Skill in the Art..... 16

VI. CLAIM CONSTRUCTION ..... 16

VII. GROUND 1: CLEVELAND ANTICIPATES CLAIMS 1-3 AND	
11 .....	17
A. Cleveland.....	17
1. Overview .....	17
2. <i>Dynamic Drinkware</i> Analysis.....	17
a. The Cleveland Provisional’s written description supports at least one claim of Cleveland .....	18
b. The subject matter relied upon was effectively filed in the ’258 Provisional .....	21
B. Independent Claim 1 .....	22
1. [1.pre] “A product in the form of a cup comprising a laminated forming moisture barriers, said laminated comprising:” .....	22
2. [1.1] “a paperboard substrate having a separate interior product facing surface and a separate exterior surface;” .....	25
3. [1.2] “a first moisture protectant layer is coated directly only on said interior surface of said paperboard substrate” .....	27
4. [1.3.1] “and comprising at least one biodegradable polyester polymer,.....	31
5. [1.3.2] “wherein the first moisture protectant layer has a coat weight of from 5 to 30 lbs./3000 ft <sup>2</sup> ” .....	33
6. [1.4] “a second moisture protectant layer is coated directly only on said exterior surface of said paperboard substrate” .....	36
7. [1.5.1] “and comprising at least one biodegradable polyester polymer” .....	38

8.	[1.5.2] “wherein the second moisture protectant layer has a coat weight of from 5 to 30 lbs./3000 ft <sup>2</sup> ” .....	39
9.	[1.6] “and is separate from the first moisture protectant layer coated on and directly adhered to said interior surface of said substrate” .....	40
C.	Dependent Claim 2 .....	42
1.	[2.1]: “The product according to claim 1, wherein the second moisture protectant layer further comprises from 5 to 20 percent by weight of at least one filler selected from the group consisting of calcium carbonate and starch.” .....	42
D.	Dependent Claim 3 .....	43
1.	[3.1] “The product according to claim 1, wherein the first moisture protectant layer further comprises from 5 to 20 percent by weight of at least one filler selected from the group consisting of calcium carbonate and starch.” .....	43
E.	Dependent Claim 11 .....	43
1.	[11.1] “The product according to claim 3, wherein the first moisture protectant layer comprises from 5 to 20 percent by weight of calcium carbonate as the filler.” .....	43
VIII.	GROUND 2: NAKAGAWA ALONE OR IN VIEW OF APPLICANT’S ADMITTED PRIOR ART RENDERS OBVIOUS CLAIMS 1-3, 11 .....	44
A.	Overview of Nakagawa .....	44
B.	Independent Claim 1 .....	46
1.	[1.pre] “A product in the form of a cup comprising a laminate forming moisture barriers, said laminate comprising:” .....	46

2.	[1.1] “a paperboard substrate having a separate interior product facing surface and a separate exterior surface;” .....	48
3.	[1.2] “a first moisture protectant layer is coated directly only on said interior surface of said paperboard substrate” .....	50
4.	[1.3.1] “and comprising at least one biodegradable polyester polymer” .....	51
5.	[1.3.2] “wherein the first moisture protectant layer has a coat weight of from 5 to 30 lbs./3000 ft <sup>2</sup> ” .....	54
	a. Nakagawa discloses coat weights of 5 to 30 lbs./3000 ft <sup>2</sup> .....	54
	b. Alternatively, Applicant’s Admitted Prior Art discloses coat weights of <b>5 to 30 lbs./3000 ft<sup>2</sup></b> .....	55
	c. Nakagawa-’126 Patent’s admitted prior art Combination .....	55
	d. Rationale to Combine Nakagawa and the prior art admitted by the ’126 Patent.....	56
	i. <i>KSR</i> Rationale: Obvious to try— Choosing from a Finite Number of Identified, Predictable Solutions, with a Reasonable Expectation of Success .....	58
6.	[1.4] “a second moisture protectant layer is coated directly only on said exterior surface of said paperboard substrate” .....	60
7.	[1.5.1] “and comprising at least one biodegradable polyester polymer” .....	62
8.	[1.5.2] “wherein the second moisture protectant layer has a coat weight of from 5 to 30 lbs./3000 ft <sup>2</sup> ” .....	62

9.	[1.6] “and is separate from the first moisture protectant layer coated on and directly adhered to said interior surface of said substrate” .....	63
C.	Dependent Claim 2 .....	65
1.	[2.1]: “The product according to claim 1, wherein the second moisture protectant layer further comprises from 5 to 20 percent by weight of at least one filler selected from the group consisting of calcium carbonate and starch.” .....	65
D.	Dependent Claim 3 .....	66
1.	[3.1] “The product according to claim 1, wherein the first moisture protectant layer further comprises from 5 to 20 percent by weight of at least one filler selected from the group consisting of calcium carbonate and starch.” .....	66
E.	Dependent Claim 11 .....	67
1.	[11.1] “The product according to claim 3, wherein the first moisture protectant layer comprises from 5 to 20 percent by weight of calcium carbonate as the filler.” .....	67
IX.	GROUND 3: NAKAGAWA IN VIEW OF TANNER RENDERS OBVIOUS CLAIMS 1-3, 11 .....	68
A.	Overview of Tanner.....	68
B.	Independent Claim 1 .....	68
1.	[1.pre] “A product in the form of a cup comprising a laminate forming moisture barriers, said laminate comprising:” .....	68
2.	[1.1] “a paperboard substrate having a separate interior product facing surface and a separate exterior surface;” .....	68

3.	[1.2] “a first moisture protectant layer is coated directly only on said interior surface of said paperboard substrate” .....	69
4.	[1.3.1] “and comprising at least one biodegradable polyester polymer” .....	69
5.	[1.3.2] “wherein the first moisture protectant layer has a coat weight of from 5 to 30 lbs./3000 ft <sup>2</sup> ” .....	69
a.	Tanner discloses coat weights of 5 to 30 lbs./3000 ft <sup>2</sup> .....	69
b.	Nakagawa-Tanner Combination.....	70
c.	Rationale to Combine Nakagawa and Tanner .....	71
i.	<i>KSR</i> Rationale: Obvious to try – Choosing from a Finite Number of Identified, Predictable Solutions, with a Reasonable Expectation of Success .....	73
6.	[1.4] “a second moisture protectant layer is coated directly only on said exterior surface of said paperboard substrate” .....	74
7.	[1.5.1] “and comprising at least one biodegradable polyester polymer” .....	74
8.	[1.5.2] “wherein the second moisture protectant layer has a coat weight of from 5 to 30 lbs./3000 ft <sup>2</sup> ” .....	74
9.	[1.6] “and is separate from the first moisture protectant layer coated on and directly adhered to said interior surface of said substrate” .....	75
C.	Dependent Claim 2 .....	75
1.	[2.1]: “The product according to claim 1, wherein the second moisture protectant layer further comprises from 5 to 20 percent by weight of at least one filler	

selected from the group consisting of calcium carbonate and starch.” .....75

D. Dependent Claim 3 .....76

1. [3.1] “The product according to claim 1, wherein the first moisture protectant layer further comprises from 5 to 20 percent by weight of at least one filler selected from the group consisting of calcium carbonate and starch.” .....76

E. Dependent Claim 11 .....76

1. [11.1] “The product according to claim 3, wherein the first moisture protectant layer comprises from 5 to 20 percent by weight of calcium carbonate as the filler.” .....76

X. NO SECONDARY CONSIDERATIONS .....77

XI. INSTITUTION IS APPROPRIATE.....77

XII. CONCLUSION.....78

**TABLE OF AUTHORITIES**

<b>Cases</b>	<b>Page(s)</b>
<i>Advanced Bionics, LLC v. MED-EL Elektromedizinische Geräte GmbH</i> , IPR2019-01469, Paper 6 (PTAB Feb. 13, 2020).....	78
<i>Amgen Inc. v. Sanofi</i> , 872 F.3d 1367 (Fed. Cir. 2017) .....	18
<i>Apple Inc. v. Fintiv, Inc.</i> , IPR2020-00019, Paper 11 (PTAB Mar. 20, 2020) .....	77
<i>Apple Inc. v. Telefonaktiebolaget LM Ericsson</i> , IPR2022-00348, 2022 WL 4371126 (PTAB Sept. 21, 2022) .....	18
<i>In re Bigio</i> , 381 F.3d 1320 (Fed. Cir. 2004) .....	17, 44, 68
<i>Dynamic Drinkware, LLC v. Nat’l Graphics, Inc.</i> , 800 F.3d 1375 (Fed. Cir. 2015) .....	17, 18
<i>KSR Int’l Co. v. Teleflex Inc.</i> , 550 U.S. 398 (2007).....	58, 73
<i>In re Peterson</i> , 315 F.3d 1325 (Fed. Cir. 2003) .....	66
<i>Phillips v. AWH Corp.</i> , 415 F.3d 1303 (Fed. Cir. 2005) .....	16
<i>Titanium Metals Corp. v. Banner</i> , 778 F.2d 775 (Fed. Cir. 1985) .....	35, 70
<b>Statutes</b>	
35 U.S.C. §102.....	4, 5, 17
35 U.S.C. §112.....	5, 18
35 U.S.C. §311 .....	3

35 U.S.C. §314.....77

35 U.S.C. §325 .....12, 78

**Other Authorities**

37 C.F.R. §1.56 .....13

37 C.F.R. §1.104(d)(2).....9

37 C.F.R. §42.8(b)(1).....2

37 C.F.R. §42.100(b) .....16

37 C.F.R. §42.104(a).....2

MPEP §2136.04.I.....5

MPEP §2141.01(a).I .....17, 44, 68

MPEP §2143.I.(E).....58, 73

**LIST OF EXHIBITS**

<b>Exhibit</b>	<b>Description</b>
1001	U.S. Patent No. 8,637,126 (“the ’126 Patent”)
1002	File History of the ’126 patent
1003	Declaration of Dr. Karl Englund
1004	<i>Curriculum Vitae</i> of Dr. Karl Englund
1005	U.S. Patent Application Publication No. US 2006/0051603 A1 to Cleveland (“Cleveland”)
1006	U.S. Provisional Application No. 60/608,258 to Cleveland (“’258 Provisional”)
1007	Japanese Patent Application Publication No. JP H6-62944 A to Nakagawa
1008	Certified Translation of Japanese Patent Application Publication No. JP H6-62944 A to Nakagawa
1009	U.S. Patent No. 5,213,858 to Tanner (“Tanner”)
1010	All About Wax Coated Packaging, dated June 6, 2021 (downloaded from <a href="https://blendedwaxes.com/blog/all-about-wax-coated-packaging/">https://blendedwaxes.com/blog/all-about-wax-coated-packaging/</a> )
1011	U.S. Patent Application Publication No. US 2005/0008800 A1 to Andersson (“Andersson”)
1012	U.S. Patent No. 6,183,814 to Nangeroni (“Nangeroni”)
1013	U.S. Patent No. 3,984,940 to Reich (“Reich”)
1014	U.S. Patent No. 6,040,063 to Doane (“Doane”)
1015	U.S. Patent No. 6,025,028 to Asrar (“Asrar”)
1016	U.S. Patent No. 6,645,584 B1 to Kuusipalo (“Kuusipalo”)
1017	Japanese Unexamined Patent Application Publication No. JP 2003-13391 A to Yamawaki (“Yamawaki”) and Certified English Translation of Yamawaki
1018	U.S. Patent Application Publication No. 2004/0014883 A1 to Yamamoto (“Yamamoto”)

Exhibit	Description
1019	Eastar Bio/Ecoflex Wikipedia page ( <a href="https://en.wikipedia.org/wiki/Polybutylene_adipate_terephthalate">https://en.wikipedia.org/wiki/Polybutylene_adipate_terephthalate</a> ) and ecoflex® - Certified Compostable Plastic brochure (downloaded from <a href="https://plastics-rubber.basf.com/global/en/performance_polymers/downloads#%7B%22%22:%5B%5B%22productId%22,%5B%228a8082c97eaf959c017ec37846992be7%22%5D%5D%5D%7D">https://plastics-rubber.basf.com/global/en/performance_polymers/downloads#%7B%22%22:%5B%5B%22productId%22,%5B%228a8082c97eaf959c017ec37846992be7%22%5D%5D%5D%7D</a> )
1020	Frederick Trinh Tan <i>et al.</i> , <i>Biodegradation of a synthetic co-polyester by aerobic mesophilic microorganisms</i> , 93 <i>Polymer Degradation &amp; Stability</i> , 1479-1485 (August 2008).
1021	Gaurav Kale <i>et al.</i> , <i>Compostability of Bioplastic Packaging Materials: An Overview</i> , 7 <i>Macromolecular Bioscience</i> , 255-277 (March 2007).
1022	ASTM D6400 – 23: Standard Specification for Labeling of Plastics Designed to be Aerobically Composted in Municipal or Industrial Facilities
1023	ASTM D6868 – 21: Standard Specification for Labeling of End Items that Incorporate Plastics and Polymers as Coatings or Additives with Paper and Other Substrates Designed to be Aerobically Composted in Municipal or Industrial Facilities
1024	Ariagna L. Rivera-Briso and Ángel Serrano-Aroca, <i>Poly(3-Hydroxybutyrate-co-3-Hydroxyvalerate): Enhancement Strategies for Advanced Applications</i> . 10 <i>Polymers</i> , 732 (July 2018).
1025	Biomax PlasticsNet page ( <a href="https://www.plasticsnet.com/doc/dupont-biomax-0001">https://www.plasticsnet.com/doc/dupont-biomax-0001</a> )

Clearwater Paper Corporation (“Petitioner”) requests *inter partes* review to cancel claims 1-3 and 11 (“Challenged Claims”) of U.S. Patent No. 8,637,126 (“the ’126 Patent,” EX1001), assigned to Graphic Packaging International, LLC (“Patent Owner”).

## **I. INTRODUCTION**

The ’126 Patent claims a standard paper cup that is coated, in well-known coat weights, with a biodegradable polyester polymer on both the inside and outside of the cup. As admitted in the ’126 Patent, (1) paper cups coated with polymers were known; (2) coat weights of 7.2-21.6 lbs./3000 ft<sup>2</sup> were commonly used; and (3) biodegradable polymers, including the specific ones described in the specification, were known and commercially available. According to the ’126 Patent itself, the purported invention amounts to nothing more than swapping out the use of a non-degradable polymer for a biodegradable polymer.

Petitioner presents two prior art references that demonstrate the use of biodegradable polymers as coatings for paper cups, rendering the Challenged Claims anticipated or obvious. *See* EX1005; EX1008. Neither reference was considered by the Examiner during their prolonged examination of the ’126 Patent. Had the Examiner been aware of these references, the ’126 Patent would have never issued.

**II. MANDATORY NOTICES**

**A. Real Party-in-Interest**

Pursuant to 37 C.F.R. §42.8(b)(1), Petitioner Clearwater Paper Corporation identifies itself as the real party-in-interest.

**B. Related Matters**

Petitioner is not aware of any related matters.

**C. Lead and Back-up Counsel and Service Information**

Lead Counsel	Back-up Counsel
James D. Stein (Reg. No. 63,782) Lee & Hayes, P.C. 75 14 <sup>th</sup> Street NE, Suite 2500 Atlanta, GA 30309 Phone: 404.736.1918 james.stein@leehayes.com	Steven Philbin (Reg. No. 81,544) Lee & Hayes, P.C. 75 14 <sup>th</sup> Street NE, Suite 2500 Atlanta, GA 30309 Phone: 404.736.1860 steven.philbin@leehayes.com  Robert J. Carlson (Reg. No. 35,472) Lee & Hayes, P.C. 701 Pike Street, Suite 1600 Seattle, Washington 98101 Phone: 206.876.6029 bob@leehayes.com

Petitioner consents to service by email at the following email address:  
ClearwaterPaper-PTAB@leehayes.com.

**III. CERTIFICATION OF GROUNDS FOR STANDING**

Petitioner certifies under 37 C.F.R. §42.104(a) that the '126 Patent is available for *inter partes* review and that Petitioner is not barred or estopped from requesting

*inter partes* review challenging the '126 Patent claims on the grounds identified in this Petition.

#### IV. STATEMENT OF PRECISE RELIEF REQUESTED

##### A. Claims for Which Review Is Requested

Petitioner requests *inter partes* review and cancellation of claims 1-3 and 11 (“the Challenged Claims”) of the '126 Patent under 35 U.S.C. §311 based on the following Grounds 1-3. This Petition is supported by the Declaration of Dr. Karl Englund (EX1003), Petitioner’s expert in the subject matter of the '126 Patent.

##### B. Statutory Grounds of Challenge<sup>1</sup>

Ground	Basis	Claims	Reference(s)
1	Anticipation (35 U.S.C. §102)	1-3 and 11	• U.S. Patent Application Publication No. US2006/0051603 to Cleveland (EX1005, “Cleveland”)

---

<sup>1</sup> The pre-America Invents Act (“AIA”) provisions of Title 35 apply to the '126 Patent because it was filed in 2006.

2	Obviousness (35 U.S.C. §103)	1-3 and 11	<ul style="list-style-type: none"> <li>• Japanese Patent Application Publication No. JP H6-62944 to Nakagawa et al. (EX1007, “Nakagawa”)<sup>2</sup></li> <li>• Applicant’s Admitted Prior Art in the ’126 Patent</li> </ul>
3	Obviousness (35 U.S.C. §103)	1-3 and 11	<ul style="list-style-type: none"> <li>• Nakagawa</li> <li>• U.S. Patent No. 5,213,858 to Tanner et al. (EX1009, “Tanner”)</li> </ul>

Cleveland is a published U.S. Patent Application filed on September 7, 2005 and claiming priority to Provisional Application No. 60/608,258 (EX1006, “Cleveland Provisional”) filed September 9, 2004. EX1005, 1. Cleveland and the ’126 Patent are both assigned to Patent Owner but have different sets of inventors—Cleveland lists inventors C. Cleveland and T. Reighard while the ’126 Patent lists these two inventors plus J. Marchman. *Compare* EX1001, 1 *with* EX1005, 1. Thus, Cleveland is “an application for patent, published under section 122(b), **by another** filed in the United States...” for purposes of pre-AIA 35 U.S.C. §102(e)(1). As the MPEP explains:

---

<sup>2</sup> A certified English translation of Nakagawa is provided as EX1008.

“Another” means other than applicants, *In re Land*, 368 F.2d 866 [] (CCPA 1966), in other words, a different inventive entity. The inventive entity is different if not all inventors are the same. The fact that the application and reference have one or more inventors in common is immaterial. *Ex parte DesOrmeaux*, No. 92-2849, 25 U.S.P.Q.2d 2040 ([B.P.A.I.] 1992).

MPEP §2136.04.I.

As explained below in Section VII.A.2, the Cleveland Provisional provides Section 112 support for at least one claim of Cleveland. Thus, Cleveland qualifies as prior art under §102(e)(1) based on each of its provisional and nonprovisional filing dates of September 2005 and September 2006, respectively.

Nakagawa is a Japan Patent Application published on March 8, 1994, thus qualifying as prior art under §§102(a) and (b). EX1008, 1.

Tanner is a U.S. Patent issued in 1993, also qualifying as prior art under §§102(a) and (b). EX1009, 1.

## **V. U.S. PATENT NO. 8,637,126**

### **A. Background**

Paper is a common base material for food packaging, such as cups, but paper has undesirable physical limitations such as “porosity to deleterious liquids or gases” and a lack of “tear resistance.” EX1001, 1:15-18. To overcome these limitations, the

'126 Patent explains it was conventional practice to laminate the paper material with polymeric materials—typically low-density polyethylene (LDPE). *Id.*, 1:19-35.

While paper is biodegradable, LDPE is not, so an LDPE-coated paper “cup might remain in a landfill for many years without degrading.” *Id.*, 1:45-49. But the '126 Patent admits this was a known problem with a known solution: replace the non-degradable LDPE with a biodegradable polymer. *Id.*, 1:49-51. The '126 Patent also acknowledges that such biodegradable polymers were known, including “polylactic acid (PLA) and “polyhydroxyalkanoates (PHA).” *Id.*, 2:10-12. The purported invention of the '126 Patent merely replaced LDPE with a known biodegradable polymer (PLA or PHA).

When laminating a coating material to a paper substrate, the amount or thickness of the coating material is referred to as the “coat weight.” *See* EX1003, ¶28; EX1001, 1:43-55, 2:52-3:14. An industry standard unit for describing the coat weight is pounds per 3,000 ft<sup>2</sup>—the total surface area of a 24” x 36” ream of paper (250 sheets). This industry standard unit informs as to the amount in pounds of the coating material to be used for a ream of paper substrate. *See* EX1001, 1:43-44, 1:61-62; EX1009, 2:57-60; EX1010, 1; EX1003, ¶28.

For example, as acknowledged in the '126 Patent, 7.2-21.6 lbs./3000 ft<sup>2</sup> coat weights of LDPE were common for paper cups. EX1001, 1:40-44. In other words, it was known in the art to use between 7.2-21.6 lbs. of LDPE to coat an entire ream of

paper substrate, which is then formed into paper cups. This known coat weight range falls completely within the '126 Patent's claimed range of 5 to 30 lbs.

## **B. Prosecution History**

The '126 Patent was filed as Application No. 11/348,150 on February 6, 2006. EX1002, 1. It does not claim the benefit of any prior filings.

As originally filed, the application had 73 claims. *Id.*, 15-30. A restriction requirement was issued, as the Examiner had identified two claimed inventions: a laminate with oxygen barrier properties (claims 1-58), and a method for making biodegradable paper products (claims 59-73). *Id.*, 260-267. Further, the Examiner identified several purportedly patentably-distinct species within the claim set. *Id.*, 264. Applicant ultimately elected the species as defined by claims 1-35, 38 and 41-43 for prosecution—a laminate comprising a polymeric protectant layer, moisture protective layer, and degradable tie layer. *Id.*, 281-282.

Following the Applicant's election, prosecution continued for five years, with extensive back-and-forth between the Applicant and Examiner. Throughout the numerous office actions, Examiner repeatedly rejected the pending claims based on twelve different prior art references in various combinations. The primary areas of dispute during prosecution related to (1) degradability of the moisture protectant layers, (2) the coat weight of the moisture protectant layers, (3) the lack of an intervening layer between the moisture protectant layer and the paperboard

substrate, and (4) the inclusion of a filler, such as calcium carbonate or starch, in the moisture protectant layer. Petitioner summarizes each subject below.

**1. Degradability of the moisture protectant layers**

As originally claimed, the '126 Patent required “degradable” materials for the various layers of its laminate. EX1002, 15-26. The Examiner first cited U.S. Patent Application Publication No. US2005/0008800 (EX1011, “Andersson”) as disclosing a degradable polyethylene. EX1002, 285. In response, Applicant argued that the polyethylene disclosed by Andersson, and other “normal” polyethylenes, are not degradable:

Degradability is defined as a >75-80% loss in molecular weight (MWT) in a relatively short amount of time (<9 months) due to exposure to oxygen, water, and microbes in the environment. This process is the same as the degradation of other organic materials like food waste. Normal polyethylene is not considered to be degradable because it might take tens to hundreds of years to achieve the >75% loss in molecular weight. Standards and definitions for degradability are contained in ASTM D6400, ASTM D6868, and ASTM D5511. More specifically, degradable polyethylene is defined in ASTM D3826.

*Id.*, 306.

In response to a subsequent office action, Applicant argued that the degradable polymer disclosed in U.S. Patent No. 3,984,940 (EX1013, “Reich”) was unsuitable for the purposes of the claimed invention because it degrades in sunlight instead of being biodegradable. EX1002, 330. The Examiner rejected this argument, as the pending claims did not delineate between “biodegradable” and “degradable.” *Id.*, 340-341. Applicant amended the claims to specify that the polymers must be “biodegradable”—not just “degradable.” *Id.*, 345. Applicant did not contest that Examiner’s cited prior art applied in the remaining rejections taught biodegradable polymers.

**2. Coat weight of the moisture protectant layers.**

The Examiner repeatedly stated that although the prior art references it cited did not disclose the coat weight, it would have been obvious to use the claimed coat weight depending on the desired weight of the packaging. *See, e.g.*, EX1002, 286-287, 314, 381-382, 891, 1063-1064. Applicant repeatedly argued that Examiner’s statements were conclusory and unsupported. *See, e.g., id.*, 400, 907-908, 1016. Applicant argued that Examiner’s statement that the coat weight would have been obvious must have been based on Examiner’s personal knowledge, which was not provided to the Applicant, and therefore requested an affidavit/declaration under 37 C.F.R. §1.104(d)(2) supporting the Examiner’s purported personal knowledge. *See, e.g.*, EX1002, 437, 439, 669-670, 673, 700, 705, 1016-1017, 1054-1055. The

Examiner never provided an affidavit/declaration regarding their personal knowledge on the issue of coat weights, nor did they concede that it would not have been obvious to use the claimed coat weight depending on the desired weight of the packaging.

In the last office action rejection, the Examiner cited Japanese Patent No. JP 2003-13391 A (EX1017, “Yamawaki”) as disclosing the claimed coat weight. EX1002, 1092-1093. Applicant argued that the coating weight disclosed in Yamawaki (5 to 30 g/m<sup>2</sup>) was not equivalent to the claimed coating weight of 5 to 30 lbs/3000 ft<sup>2</sup>. *Id.*, 1135. Applicant did not explain why the coating weights were not equivalent. The Examiner subsequently allowed the claims, in part based on the prior art failing to disclose “a coat weight of from 5 to 30 lbs/3000 ft<sup>2</sup>.” EX1002, 1151.

**3. Lack of intervening layer between the moisture protectant layer and the paperboard substrate**

Near the end of the prosecution of the '126 Patent, Applicant amended the claims so that the moisture protectant layers were “coated directly” on the interior and exterior surfaces of the substrate. EX1002, 1076. Examiner cited the combination of Yamawaki (EX1017) and U.S. Patent No. 6,645,584 (EX1016, “Kuusipalo”) as disclosing the moisture protectant layers being coated directly on the substrate. EX1002, 1092-1093. The Applicant argued in response that Kuusipalo

requires an intervening adhesive layer, therefore it does not teach coating the moisture protectant layer directly on the substrate. *Id.*, 1136. The Examiner subsequently allowed the claims, in part based on the prior art failing to disclose the moisture protectant layers being “coated directly” on the interior and exterior surfaces of the substrate. EX1002, 1151.

#### **4. Filler content in the moisture protectant layer**

The Examiner cited several references as disclosing the use of a “filler,” including specifically “calcium carbonate,” in the moisture protectant layers. *See, e.g.*, EX1002, 381-382 (citing U.S. Patent No. 6,040,063 (EX1014, “Doane”)), 411-412 (citing U.S. Patent No. 6,025,028 (EX1015, “Asrar”)), 1034-1035 (citing U.S. Application No. 2004/0014883 (EX1018, “Yamamoto”)), 1063-1064 (citing U.S. Patent No. 6,183,814 (EX1012, “Nangeroni”)). Applicant’s arguments against these “filler” references had the same theme: the disclosed uses of calcium carbonate were not as fillers but for other (non-filler) purposes.

Regarding Doane, Applicant argued the calcium carbonate was used as a “nucleating agent” for preparing a “foam.” EX1002, 398-399, 663-665. Similarly, Applicant argued that Asrar taught using calcium carbonate to “improve nucleation activity.” *Id.*, 432. For Yamamoto, Applicant conceded disclosure of a filler, but argued that the “reasons for incorporating” calcium carbonate as a filler in the polyester film were “completely unstated.” *Id.*, 1056. Finally, for Nangeroni,

Applicant argued that the purported filler was instead as described as “a pigment.” *Id.*, 1139. The Examiner subsequently allowed the claims, but did not address the filler element in the statement of reasons for allowance. EX1002, 1151.

**C. Petitioner’s Prior Art Undercuts the Examiner’s Reasons for Allowance.**

Per the Examiner’s statement of reasons for allowance, the ’126 Patent was allowed because the cited prior art failed to disclose a paperboard substrate with a biodegradable moisture protectant layer coated directly on each side of the substrate in a broad coat weight range:

The prior art of record...fails to disclose a product in the form of a cup comprising a laminate comprising a paperboard substrate having an interior facing surface and an exterior surface, a first moisture protectant layer coated directly only on the interior surface and comprising at least one biodegradable polyester polymer having a coat weight of from 5 to 30 lbs/3000 ft<sup>2</sup> and a second moisture protectant layer coated directly only on the exterior surface comprising at least one biodegradable polyester polymer having a coat weight of from 5 to 30 lbs/3000 ft<sup>2</sup>.

EX1002, 1151. Petitioner presents prior art that (1) was not considered by the Examiner, and (2) discloses exactly what the Examiner based the allowance of the

'126 Patent on. Thus, the Board should accept this Petition and not exercise its discretion under 35 U.S.C. §325(d) to deny institution.

Petitioner presents Cleveland, Nakagawa, and Tanner— prior art known in the field before the effective filing date of the '126 Patent and not cited or considered by the Examiner during prosecution.

Cleveland, filed on September 7, 2005, discloses a paper-based substrate having moisture-protectant layers laminated on both sides, without intervening adhesive layers. EX1005, Abstract.

Nakagawa, filed on August 24, 1992, “relates to a biodegradable paper cup” that “is laminated with plastic on at least one side or both sides of the paper.” EX1008, ¶¶[0001], [Claim 1].

Further, Tanner, which is a continuation of an application filed on April 4, 1990, discusses a “biodegradable paperboard-based laminate structure for producing a degradable paperboard-based package” that comprises “a paperboard substrate having an interior side and an exterior side” with “biodegradable polymer resin applied on said exterior side of said paperboard substrate.” EX1009, 5:1-12.

Additionally, Cleveland and Tanner were each originally assigned to International Paper Co. – the same company that filed the '126 Patent. Cleveland shares two of the same inventors as the '126 Patent. Despite their common ownership and disclosures pertinent to patentability, neither Cleveland nor Tanner

was cited in an Information Disclosure Statement during or after prosecution of the '126 Patent, as required by 37 C.F.R. §1.56. EX1002, 59-64.

As another example of Petitioner's arguments substantially differing from those considered during prosecution, in Applicant's Response to a Final Office Action dated July 13, 2013 (Applicant's final Response filed in prosecution), Applicant misled the Examiner that Yamawaki did not disclose the claimed coat weight because Yamawaki used Imperial, not metric, units of measurement. Specifically, Applicant contended that the Office Action,

**mischaracterizes** what **Yamawaki et al.** fairly teaches in paragraph 0022 regarding the coating amount of its biodegradable resin. What **Yamawaki et al.** teaches in paragraph 0022 is that coating amount is "*preferably 5 to 30 g/m<sup>2</sup>.*" By contrast, amended Claim 76 recites that the coat weight for each of the first and second moisture protectant layers is from 5 to 30 **lbs/3000 ft<sup>2</sup>**. Nowhere does [the Office Action] show how the coating amount disclosed in paragraph 0022 of **Yamawaki et al.** is equivalent to or even comparable to the coating weight recited for each of the first and second moisture protectant layers of amended Claim 76.

EX1002, 1135 (emphasis in original; italics added).

For context, the claimed coat weight unit of pounds per 3000 ft<sup>2</sup> in the '126 Patent is an ordinary Imperial unit of measurement in the art, expressed as a weight (mass) per area. EX1003, ¶47. This same measurement in the metric system is g/m<sup>2</sup>, also expressed as a weight (mass) per square area. In other words, lbs./3000 ft<sup>2</sup> and g/m<sup>2</sup> represent the same concept of coat weight applications—weight per area—the former under an Imperial system and the latter under a metric system. Converting between the two is mathematically simple. To convert g/m<sup>2</sup> into lbs./3000 ft<sup>2</sup>, merely multiply the weight in pounds by 453.592 to get grams (1lb. = 453.592g) and multiply the square area by 278.709 (3000ft<sup>2</sup> = 278.709m<sup>2</sup>). Simplified, **g/m<sup>2</sup> ≈ lbs./3000 ft<sup>2</sup> x 0.614**. EX1003, ¶47.

Applicant's assertion that Yamawaki's coat weight "preferably [between] 5 to 30 g/m<sup>2</sup>" is "not equivalent to or even comparable to" the claimed coat weight recited for each of the first and second moisture protectant layers is incorrect and misleading. A simple conversion of Yamawaki's disclosed coat weight of 5 to 30 g/m<sup>2</sup> to imperial units results in a disclosed coat weight of 3.07 to 18.42 lbs./3000 ft<sup>2</sup>. This falls within the claimed range of the '126 Patent. To the extent the Examiner relied on this argument in issuing the allowance, this was in error.

Accordingly, the Examiner did not appreciate that the '126 Patent claims recited little more than applying a known polymer material in a known coat weight to the inside and the outside of a paper cup, or did not have the proper prior art

references to demonstrate it. Had the Examiner appreciated the pertinent disclosures of the cited references, considered the uncited references introduced in this Petition, or been aware of the context surrounding the units claimed (metric) and differentiated from (Imperial), the '126 Patent claims would not have issued.

**D. The Level of Ordinary Skill in the Art**

A person of ordinary skill in the art (“POSITA”) at the time of the priority date of the '126 Patent would have at least a bachelor’s degree in mechanical or chemical engineering, materials science, polymer science, or equivalent coursework, at least a year of experience developing paper-based laminates involving the extrusion coating, lamination, or other application of polymer coatings to a substrate, and the appropriate industry knowledge of or familiarity with biodegradability standards and degradability techniques. EX1003, ¶50. Less work experience may be compensated by a higher level of education, such as a master’s degree, and vice versa. *Id.*

**VI. CLAIM CONSTRUCTION**

The claim construction standard defined in *Phillips v. AWH Corp.*, 415 F.3d 1303 (Fed. Cir. 2005) applies to this proceeding. 37 C.F.R. §42.100(b). Under this standard, words in a claim are given their plain meaning, which is the meaning understood by a person of ordinary skill in the art after reading the entire patent, including the claims, specification, and prosecution history. *Phillips*, 415 F.3d at

1312-13. For purposes of this Petition, Petitioner does not believe any express constructions are necessary, and Petitioner has applied the plain meaning of the claim terms. However, Petitioner reserves the right to propose constructions if requested by the Board, raised by the Patent Owner, or if a related litigation is filed.

## **VII. GROUND 1: CLEVELAND ANTICIPATES CLAIMS 1-3 AND 11**

### **A. Cleveland**

#### **1. Overview**

Cleveland is analogous art to the '126 Patent because it relates to the same field of endeavor—biodegradable laminated paper cups. EX1003, ¶55; MPEP §2141.01(a).I (*citing In re Bigio*, 381 F.3d 1320, 1325 (Fed. Cir. 2004)). Cleveland relates to “a biodegradable laminate” for use with “shaped paper-based articles such as containers for liquid or solid, hot or cool, food products.” EX1005, Abstract; EX1006, 2. Cleveland’s biodegradable paper-based laminate comprises “a paper-based substrate having first and second copolyester layers deposited onto at least one surface of the substrate, in the substantial absence of intervening polymer layers between the substrate surface and the copolyesters deposited on the substrate surface.” *Id.*

#### **2. *Dynamic Drinkware* Analysis**

As explained above, Cleveland qualifies as prior art under §102(e) based on both its provisional and non-provisional filing dates. The Federal Circuit has held

that “a reference patent is only entitled to claim the benefit of the filing date of its provisional application if the disclosure of the provisional application provides support for the claims in the reference patent in compliance with §112 ¶1.” *Dynamic Drinkware, LLC v. Nat’l Graphics, Inc.*, 800 F.3d 1375, 1381 (Fed. Cir. 2015). The same is also true of a reference published non-provisional patent *application*, like *Cleveland. Amgen Inc. v. Sanofi*, 872 F.3d 1367, 1380 (Fed. Cir. 2017) (“Further, we have previously stated that for the non-provisional utility application to be afforded the priority date of the provisional application, . . . the written description of the provisional must adequately support the claims of the non-provisional application.”) (internal citation omitted).

In a *Dynamic Drinkware* analysis, first, a patent challenger must demonstrate that the provisional application’s “written description [provides] support for the claims of the [later] patent” or patent application. 800 F.3d at 1382. Second, a petitioner must show that the “subject matter relied upon for prior art was effectively filed in the provisional application[.]” *Apple Inc. v. Telefonaktiebolaget LM Ericsson*, IPR2022-00348, 2022 WL 4371126, at \*2 (PTAB Sept. 21, 2022).

**a. The Cleveland Provisional’s written description supports at least one claim of Cleveland**

The Cleveland Provisional’s written description is virtually identical to that of Cleveland itself. *Compare* EX1005 *with* EX1006. Petitioner provides the below

claim chart to demonstrate that the Cleveland Provisional supports at least claim 1 of Cleveland:

Claim Element	Cleveland Provisional’s Disclosure <sup>3</sup>
[1.pre] A biodegradable laminate, comprising:	“ <b>A biodegradable laminate</b> suitable for use in containers for liquid or solid, hot or cool, food products.” EX1006, 2; <i>see also id.</i> , 3 (“the present invention provides a biodegradable laminate.”).
[1.1] a paper-based substrate	“A biodegradable laminate...comprising <b>a paper-based substrate.</b> ” EX1006, 2; <i>see also id.</i> , 3 (“the substrate 12 of the laminate comprises <b>paper</b> , commonly a <b>paper-based stock</b> known as SBS cupstock or SUS (natural) kraft folding carton board), 4 (“In a preferred embodiment, the paper-based substrate of the laminae...”), 5 (“there is applied to at least one flat surface of the <b>paper-based substrate...</b> ”), 6 (“the coextrusion is applied to the ... <b>paper-based substrate.</b> ”).

---

<sup>3</sup> Emphasis added unless otherwise noted.

<p>[1.2] having laminated thereto at least one layer of a first copolyester and at least one layer of a second copolyester;</p>	<p>“A biodegradable laminate...comprising a paper-based substrate <b>having first and second copolyester layers coextruded onto at least one surface of the substrate.</b>” EX1006, 2; <i>see also id.</i>, 4 (“the laminate of the present invention includes...<b>a first copolyester 26 and a second copolyester 28.</b>”), 5 (“in a preferred embodiment...a paper-based substrate is provided on one flat surface thereof with a coextruded layer of <b>Ecoflex and Biomax.</b>”).</p>
<p>[1.3] said layers being deposited onto at least one surface of said substrate,</p>	<p>“A biodegradable laminate...comprising a paper-based substrate having first and second copolyester layers coextruded <b>onto at least one surface of the substrate.</b>” EX1006, 2; <i>see also id.</i>, 5 (“in a preferred embodiment...<b>a paper-based substrate is provided on one flat surface thereof</b> with a coextruded layer of Ecoflex and Biomax.”).</p>
<p>[1.4] wherein a first layer is an inner layer providing adhesion to the paper-based substrate,</p>	<p>“...the coextrusion of two copolyesters provides multiple benefits. For example, Eastar Bio and Ecoflex adhere well to paper, resulting in 100% fiber tear... Thus, in the present invention, <b>the Eastar Bio or Ecoflex layer of the coextrusion is disposed directly adjacent to the paperboard substrate to gain good adhesion.</b>” EX1006, 9.</p>

<p>[1.5] and a second layer is an outer layer preventing chill roll sticking and blocking in the roll and providing greater thermal stability compared to said first layer.</p>	<p>“Further, it has been found that use of either of the copolyesters as a <b>monolayer</b> in a laminate for biodegradation purposes <b>typically requires slip/antiblock additive packages to prevent chill roll sticking and blocking in the roll</b> of finished laminate...Employing a <b>coextrusion of the noted copolyesters has been found effective in overcoming the shortcomings of the copolyesters</b> when applied as a monolayer.” EX1006, 6.</p> <p>“...the coextrusion of two copolyesters provides multiple benefits...Biomax has a significantly higher melting point than either Eastar Bio or Ecoflex...so that the positioning of the <b>Biomax as the outermost layer of the laminate</b> in contact with the hot food product <b>allows a container formed from the laminate to better withstand deterioration and softening of the coating</b> by the hot food product.” EX1006, 9.</p>
---	---

**b. The subject matter relied upon was effectively filed in the '258 Provisional**

For Ground 1, Petitioner relies on Cleveland’s disclosure as anticipating claims 1-3 and 11 of the '126 Patent. *Infra* Sections VII.B-E. This subject matter was effectively filed in the Cleveland Provisional, as evidenced by Petitioner’s parallel citations to both Cleveland and the Cleveland Provisional. *Id.*

**B. Independent Claim 1**

1. [1.pre] **“A product in the form of a cup comprising a laminate forming moisture barriers, said laminate comprising:”**

To the extent the preamble is limiting, Cleveland discloses this element. EX1003, ¶59. Specifically, Cleveland discloses *a product* (paper-based biodegradable laminate 10) *in the form of a cup* (paper-based drinking cup) *comprising a laminate forming moisture barriers* (coextruded biodegradable laminate 14, 16):

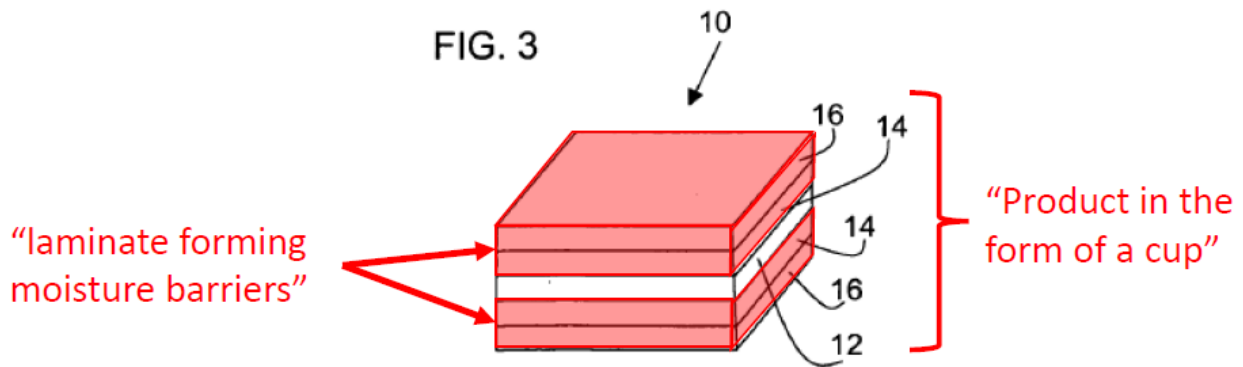

**Cleveland, FIG. 3\*<sup>4</sup>**

The coextruded “biodegradable laminate [is] suitable for use in...containers for liquid or solid, hot or cool, food products.” EX1005, Abstract; EX1006, 2. Such containers include “paper-based cup[s].” EX1005, ¶[0019], claim 17 (“biodegradable shaped article” can be a “cup[ ]”); EX1006, 4. Because the

---

<sup>4</sup> Petitioner identifies annotated or otherwise modified Figures with “\*”.

biodegradable laminate is intended for paper-based cups or other containers, the laminate must act as a moisture barrier “in order to hold liquids for a longer period of time without leaking or becoming soft.” EX1005, ¶[0003]; EX1006, 1.

Petitioner relies on Cleveland’s Figure 3 embodiment—showing a laminate 10 for “[c]ontainers for cool food products”—as anticipating ’126 Patent claims 1-3 and 11. EX1005, ¶[0032]; EX1006, 7; EX1003, ¶61. Cleveland’s Figure 3 embodiment includes all elements of claims 1-3 and 11, as arranged in these claims. Regarding Element [1.pre], specifically:

***Product in the form of a cup:*** As highlighted above, Cleveland Figure 3 shows “a biodegradable laminate 10 which is paper-based..., commonly a paper-based stock known as SBS cupstock.” EX1005, ¶[0024]; EX1006, 3. Entitled “[b]iodegradable **paper-based cup** or package and production method,” EX1005, 1; EX1006, 1, Cleveland explains that its laminates “were converted into cups.” EX1005, ¶[0037]; EX1006, 8. Thus, Cleveland’s Figure 3 biodegradable laminate 10 corresponds to the claimed *product in the form of a cup*. EX1003, ¶62.

***Laminate forming moisture barriers:*** Also highlighted in Cleveland Figure 3, layers 14 and 16 correspond to the claimed *laminate forming moisture barriers*. EX1003, ¶63. Cleveland explains that the laminate 10 “further includes first and second layers 14 and 16, respectively, of copolyesters which are coextruded onto one 18 of the surfaces of the paper-based substrate.” EX1005, ¶[0025]; EX1006, 3-

4. The coextrusion includes Eastar Bio (or Ecoflex) 14 and Biomax 16, with Biomax 16 disposed further from the substrate 12<sup>5</sup>--i.e., on the outside:

Containers for cool food products preferably are formed from a laminate as depicted in FIG. 3. This depicted laminate includes a paper-based substrate having a first layer of coextruded Eastar Bio or Ecoflex (preferably Ecoflex) and Biomax provided on one flat surface of the substrate, the Biomax being disposed outermost from the substrate. Further a second layer of coextruded Eastar Bio or Ecoflex (preferably Ecoflex) and Biomax is provided on the opposite flat surface of the substrate, the Biomax again being disposed outermost from the substrate.

EX1005, ¶[0032]; EX1006, 7. Eastar Bio, Ecoflex, and Biomax are biodegradable, water-resistant polymers used in food packaging, and thus provide a *moisture*

---

<sup>5</sup> As Cleveland explains, “ECOFLEX” or “EASTAR BIO” is the trade name for a “copolymerization of benzene-1,4-dicarboxylic acid with adipic acid and 1,4-butanediol” and “BIOMAX” is the trade name for a “copolymerization of benzene-1,4-dicarboxylic acid with ethylene glycol and 1,4:3,6-dianhydro-D-sorbitol” EX1005, ¶¶[0011]-[0012]; EX1006, 5.

*barrier*, as claimed. See EX1005, ¶¶[0028]-[0040]; EX1006, 5-8; EX1019, 3, 6; EX1025; EX1003, ¶63.

As explained below for elements [1.2] and [1.3], Cleveland anticipates the Challenged Claims under two separate views: (1) the top and bottom coextruded layers 14, 16 together correspond to the claimed *first* and *second moisture protectant layers*, respectively; and (2) the top and bottom layer 14 alone corresponds to the claimed *first* and *second moisture protectant layers*, respectively. *Id.*, ¶64.

Accordingly, Cleveland discloses element [1.pre].

**2. [1.1] “a paperboard substrate having a separate interior product facing surface and a separate exterior surface;”**

Cleveland discloses this element. EX1003, ¶66. Specifically, Cleveland discloses *a paperboard substrate* (substrate 12 made of paper-based SBS cupstock) *having a separate interior product facing surface* (surface) *and a separate exterior surface* (opposite surface):

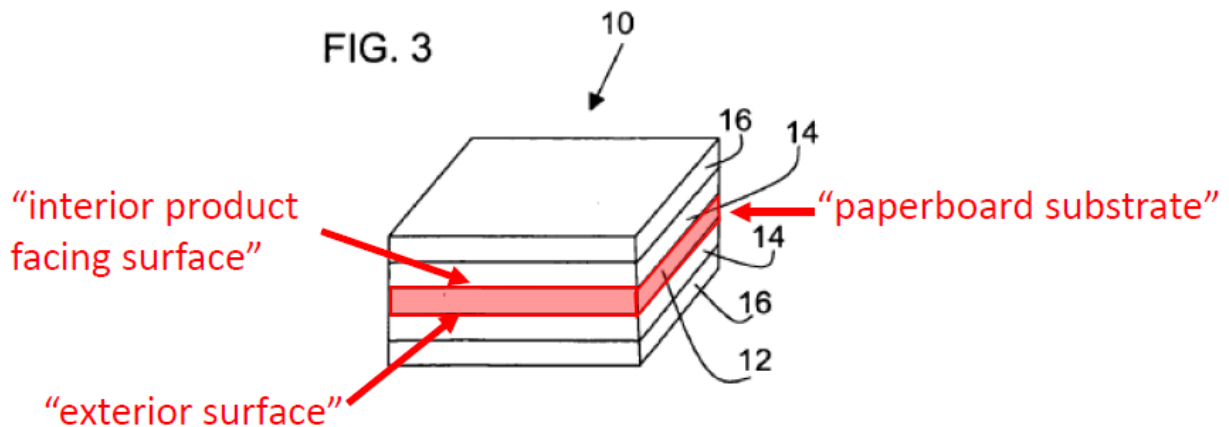

**Cleveland, FIG. 3\***

**Paperboard substrate:** As highlighted in Figure 3 above, substrate 12 corresponds to the claimed *paperboard substrate*. EX1003, ¶67. Cleveland explains that “the substrate 12 of the laminate comprises paper, commonly a paper-based stock known as SBS cupstock or SUS (natural) kraft folding carton board[.]” EX1005, ¶[0024]; EX1006, 3; *see also* EX1006, 2; EX1005, ¶[0009] (explaining that the invention of Cleveland is “a biodegradable laminate suitable for use in shaped **paper-based** articles”).

**Separate interior product facing surface and a separate exterior surface:** As highlighted in Figure 3 above, Cleveland’s substrate 12 has two opposing surfaces: the claimed *interior product facing surface* (i.e., surface facing the inside the cup) and *separate exterior surface* (i.e., surface contacting user’s hand). EX1003, ¶68. Describing the substrate 12, Cleveland explains that the laminate is deposited onto “a paper-based substrate having **two or more surfaces**.” EX1005, ¶[0009]; *see also*

*id.*, Claim 14 (“biodegradable paper-based shaped article comprising a paper-based substrate having at least two surfaces”), ¶[0032] (laminare is “provided on one flat surface of the substrate” and “on the opposite flat surface of the substrate.”); EX1006, 2 (“at least one surface of the substrate...[and] the opposite flat surface of the paper-based substrate.”).

Accordingly, Cleveland discloses or suggests element [1.1].

**3. [1.2] “a first moisture protectant layer is coated directly only on said interior surface of said paperboard substrate”**

Cleveland discloses this element under two separate views. EX1003, ¶70.

Petitioner addresses each view below.

- **View 1: Top coextruded layers 14, 16 together disclose the *first moisture protectant layer***

Cleveland discloses *a first moisture protectant layer* (top coextruded laminate layers 14, 16 together) *is coated directly only on said interior surface* (surface) *of said paperboard substrate* (substrate 12).

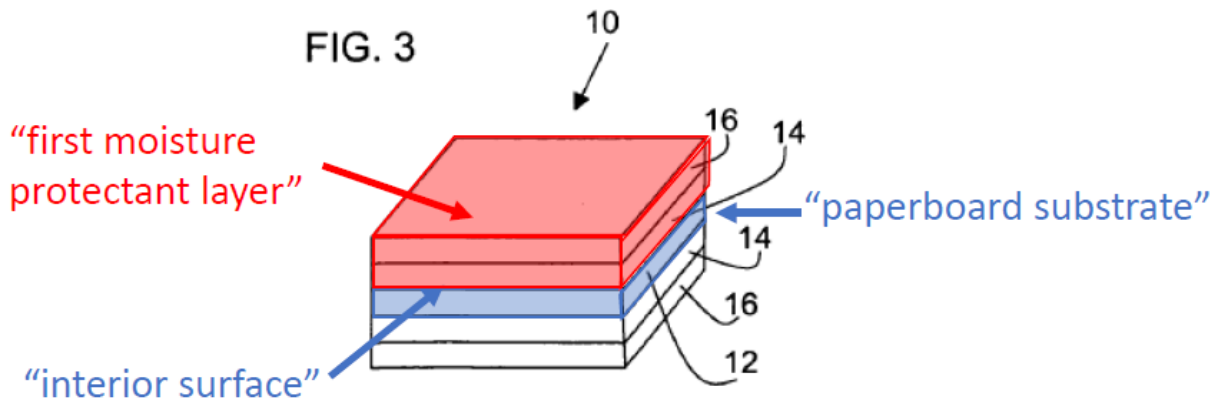

**Cleveland, FIG. 3\***

***First moisture protectant layer:*** Highlighted above, Cleveland’s Figure 3 laminate 10 “includes first and second layers 14 and 16, respectively, of copolyesters which are coextruded onto one 18 of the surfaces of the paper-based substrate [12].” EX1005, ¶[0025]; EX1006, 3-4. The coextrusion functions as a *moisture protectant* because it comprises Eastar Bio/Ecoflex 14 and Biomax 16. See EX1005, ¶¶[0025]-[0033]; EX1006, 5-7. Both materials 14, 16 are biodegradable moisture-resistant polymers. See EX1005, ¶¶[0028]-[0040]; EX1006, 5-8; EX1019, 3-6; EX1025; EX1003, ¶72. Indeed, Cleveland teaches that this “biodegradable laminate [is] suitable for use in shaped paper-based articles such as containers for liquid or solid, hot or cool, food products.” EX1005, ¶[0009]; EX1006, 2; see also EX1005, ¶[0003]; EX1006, 1 (the purpose of the biodegradable laminate is to provide “liquid resistance” so that the paper-contain can “hold liquids for a longer period of time without leaking or becoming soft.”).

Moreover, though it includes two materials, a POSITA would reasonably view the coextruded Eastar Bio/Ecoflex 14 and Biomax 16 as a single moisture protectant **layer** because Cleveland describes the combination as a single “coextruded **layer**.” EX1005, ¶[0029]; EX1006, 5. This is because, in coextrusion, both materials are applied to the substrate simultaneously, in a single step. EX1003, ¶73. Thus, Cleveland’s top coextruded layer 14, 16 discloses a *first moisture protectant layer*, as claimed.

***Coated directly only on said interior surface of said paperboard substrate:***

As shown in Figure 3 above, coextruded laminate 14, 16 is coated directly onto both surfaces of Cleveland’s paper substrate—including the *interior surface* of the cup. EX1005, ¶[0029] (“a paper-based substrate is provided on one flat surface thereof with a coextruded layer of Ecoflex and Biomax.”); EX1006, 5. Cleveland confirms that the “biodegradable laminate [is] provided on at least one surface of said [paper-based] substrate.” EX1005, Claim 14; EX1006, 2.

During prosecution, Applicant argued Kuusipalo’s moisture protectant layer was not coated “*directly only on*” the substrate because of an intervening adhesive layer. EX1002, 1136. Cleveland, however, explicitly states there is an “absence of intervening polymer layers between the [paper] substrate surface” and Cleveland’s coextruded biodegradable laminate 14, 16. EX1005, ¶[0009], EX1006, 2. While

Cleveland notes that the Eastar Bio/Ecoflex portion (14) “adhere[s] well to paper,”<sup>6</sup> this does not change the fact that Eastar Bio/Ecoflex functions as a *moisture protectant material*, as claimed. EX1003, ¶75. Therefore, Cleveland’s *moisture protectant layer*—comprising Eastar Bio/Ecoflex 14 and Biomax 16—is coated “*directly only on*” substrate 12.

- **View 2: Top Eastar Bio/Ecoflex 14 portion alone discloses the *first moisture protectant layer***

Alternatively, the Eastar Bio/Ecoflex portion 14 by itself discloses a *moisture protectant layer* that is *coated directly only on said interior surface of said paperboard substrate*:

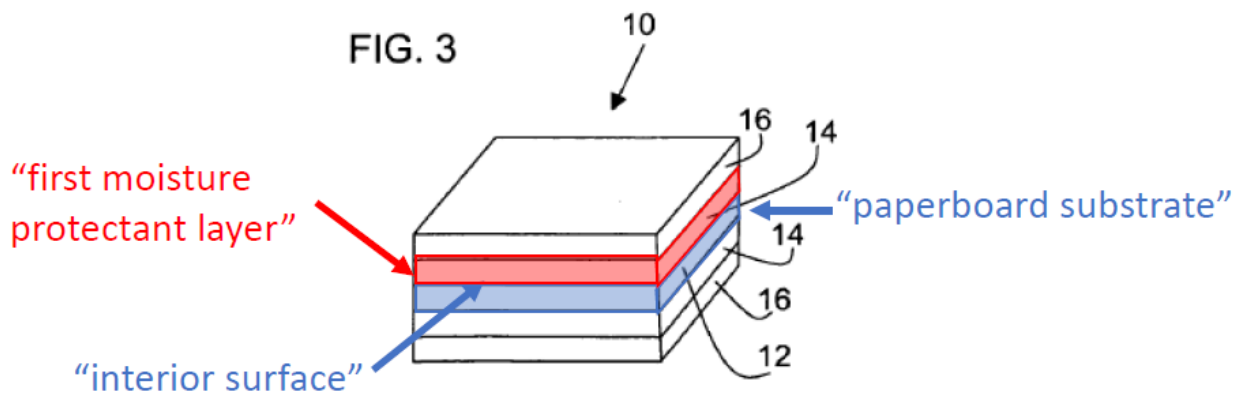

Cleveland, FIG. 3\*

---

<sup>6</sup> EX1005, ¶[0039]; EX1006, 9.

Eastar Bio and Ecoflex are both moisture-resistant polymer materials. EX1003, ¶77; EX1019, 3, 6. As shown above in Figure 3, the Eastar Bio/Ecoflex 14 material is “deposited” directly “onto at least one surface of the substrate” with an “absence of intervening polymer layers between the substrate surface and” the Eastar Bio/Ecoflex layer 14. EX1005, ¶[0009]; EX1006, 2. No intervening adhesive layer is required because the Eastar Bio/Ecoflex portion 14 “provid[es] adhesion to the paper-based substrate.” EX1005, ¶¶[0009], [0039]; EX1006, 9. And the claim language does not preclude the claimed *first moisture protectant layer*—Eastar Bio/Ecoflex portion 14—from having further layers (moisture protectant or otherwise) coated on it.

Accordingly, Cleveland discloses element [1.2].

**4. [1.3.1] “and comprising at least one biodegradable polyester polymer,**

Cleveland discloses this element. EX1003, ¶79. Specifically, Cleveland discloses that the *first moisture protectant layer* (coextruded biodegradable laminate 14, 16 or Eastar Bio/Ecoflex 14 alone) *comprises at least one biodegradable polyester polymer* (Eastar Bio/Ecoflex 14 and/or Biomax 16).

As explained for element [1.2], Cleveland’s top coextrusion 14, 16 (*first moisture protectant layer*) in Figure 3 includes Eastar Bio/Ecoflex 14 and Biomax 16. *Supra* Section VII.B.3. The former is a “copolymerization of benzene-1,4-

dicarboxylic acid with adipic acid and 1,4-butanediol” and the latter is a “copolymerization of benzene-1,4-dicarboxylic acid with ethylene glycol, and 1,4:3,6-dianhydro-D-sorbitol.” EX1005, ¶¶[0011]-[0012]; EX1006, 5. Individually, each of these copolyesters are biodegradable in a compost environment. EX1005, ¶[0029]; EX1006, 5; EX1019, 1; EX1020; EX1021, 6; EX1025. Together, “the coated laminate biodegrades in about 88 days, meeting the criteria for biodegradability/compostability according to ASTM standards D6400-99 and D6868.” EX1005, ¶[0029]; EX1006, 2; EX1022; EX1023.

Thus, Cleveland’s Eastar Bio/Ecoflex 14 and Biomax 16 are not only *biodegradable*, but also meet the “degradable” definition mentioned by Applicant during prosecution and comply with Applicant’s cited ASTM degradability standards. *See* EX1002, 306 (“Degradability is defined as a >75-80% loss in molecular weight (MWT) in a relatively short amount of time (<9 months) due to exposure to oxygen, water, and microbes in the environment” and “[s]tandards and definitions for degradability are contained in **ASTM D6400**, **ASTM D6868**,...”); EX1003, ¶81. Thus, Cleveland discloses this element even under a construction that expressly incorporates the definition provided by the ASTM standards.

Accordingly, Cleveland discloses element [1.3.1].

**5. [1.3.2] “wherein the first moisture protectant layer has a coat weight of from 5 to 30 lbs./3000 ft<sup>2</sup>”**

Cleveland discloses this element. EX1003, ¶83. Specifically, Cleveland discloses that the *first moisture protectant layer* (coextruded biodegradable laminate 14, 16 or Eastar Bio/Ecoflex 14 alone) *has a coat weight of from 5 to 30 lbs./3000 ft<sup>2</sup>* (coat weight of between about 10 and about 40 lbs./3000 ft<sup>2</sup>).

Under the first view, Cleveland discloses a total coat weight range and preferred total coat weight value for the coextruded biodegradable laminate 14, 16 of the Figure 3 embodiment:

	<b>Total Coat Weight (lbs./3000 ft<sup>2</sup>)</b>	<b>80% Eastar Bio/Ecoflex (lbs./3000 ft<sup>2</sup>)</b>	<b>20% Eastar Bio/Ecoflex (lbs./3000 ft<sup>2</sup>)</b>	<b>Citation</b>
Min	10	8	2	<p>“In this embodiment for cool food containers, the coextruded layer of copolyester (irrespective of which side of the substrate the layer is disposed) is of a total coat weight of between about 10 and about 40 lb/3000 ft<sup>2</sup>”</p> <p>EX1005, ¶[0032]; EX1006, 7.</p>
Max	40	32	8	
Preferred	25	20	5	<p>“A total coat weight of about 25 lb/3000 ft<sup>2</sup> is preferred.”</p> <p>EX1005, ¶[0032]; EX1006, 7.</p>

The disclosed total coat weight range of 10-40 lbs./3000 ft<sup>2</sup> falls almost entirely within the claimed range, and the preferred total coat weight of 25 lbs./3000 ft<sup>2</sup> falls squarely within the claimed range. Thus, Cleveland discloses element [1.3.2]. *See Titanium Metals Corp. v. Banner*, 778 F.2d 775, 782 (Fed. Cir. 1985) (“It is also an elementary principle of patent law that when, as by a recitation of ranges or otherwise, a claim covers several compositions, the claim is anticipated if one of them is in the prior art.”) (citation omitted).

Cleveland also anticipates element [1.3.2] under the second view that only the Eastar Bio/Ecoflex 14 portion of the coextrusion—immediately adjacent substrate 12—corresponds to the claimed *first moisture protectant layer*. EX1003, ¶86. Cleveland explains that the “total coat weight” can be allocated “in any combination of between about 80/20 to 20/80 parts by weight of Ecoflex [14] to Biomax [16].”<sup>7</sup> EX1005, ¶[0032]; EX1006, 7. Following this, the minimum total coat weight (10 lbs./3000 ft<sup>2</sup>) corresponds to a coat weight range for Eastar Bio/Ecoflex 14 only of 2 to 8 lbs./3000 ft<sup>2</sup> (substantially overlapping claimed range). And the maximum total coat weight (40 lbs./3000 ft<sup>2</sup>) corresponds to a coat weight range of 8 to 32

---

<sup>7</sup> Cleveland explains that Eastar Bio can be used in place of Ecoflex, but that Ecoflex is preferred. EX1005, ¶[0032]; EX1006, 7.

lbs./3000 ft<sup>2</sup> (substantially overlapping the claimed range). Similarly, if the total coat weight is 25 lbs./3000 ft<sup>2</sup>, the coat weight of Eastar Bio/Ecoflex 14 would range from 5-20 lbs./3000 ft<sup>2</sup>, which is completely within the claimed range.

Accordingly, Cleveland discloses element [1.3.2].

**6. [1.4] “a second moisture protectant layer is coated directly only on said exterior surface of said paperboard substrate”**

Cleveland discloses this element under the two views discussed above.

EX1003, ¶88. Petitioner addresses each view below.

- **View 1: Coextruded layers 14, 16 together disclose the *second moisture protectant layer***

In the same way that Cleveland’s top coextrusion 14, 16 discloses the claimed *first moisture protectant layer*, Cleveland’s bottom coextrusion 14, 16 discloses a *second moisture protectant layer* that is *coated directly only on said exterior surface* (bottom surface) of *said paperboard substrate* (substrate 12):

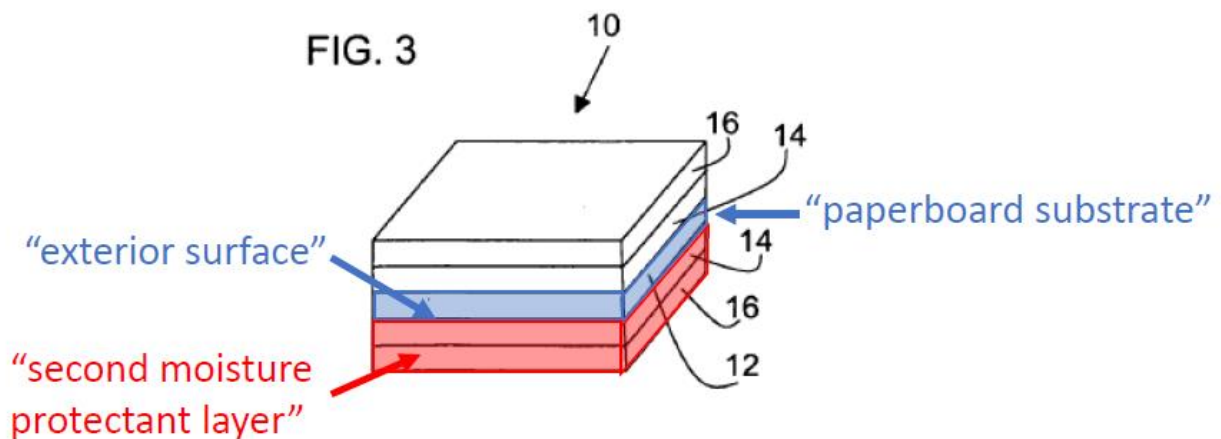

**Cleveland, FIG. 3\***

The bottom coextruded laminate 14, 16 of Cleveland's Figure 3 laminate has the same composition and configuration as the top coextruded laminate 14, 16 discussed above in Section VII.B.3, except that it is coated directly on the bottom (*exterior*) surface of substrate 12. *See, e.g.*, EX1005, ¶¶[0003], [0009], [0013]-[0015], [0032]-[0033], Claim 15; EX1006, generally. Thus, for the same reasons discussed above for the *first moisture protectant layer*, Cleveland's bottom coextruded laminate 14, 16 of Figure 3 discloses a *second moisture protectant layer* that *is coated directly only on said exterior surface of said paperboard substrate*, as claimed. EX1003, ¶91.

- **View 2: Eastar Bio/Ecoflex 14 portion alone discloses the *second moisture protectant layer***

Likewise, in the same way that Cleveland's top Eastar Bio/Ecoflex 14 layer alone discloses the claimed *first moisture protectant layer*, the bottom Eastar Bio/Ecoflex 14 layer alone can be considered the *second moisture protectant layer*, which is *coated directly only on said exterior surface* (bottom surface) *of said paperboard substrate* (substrate 12):

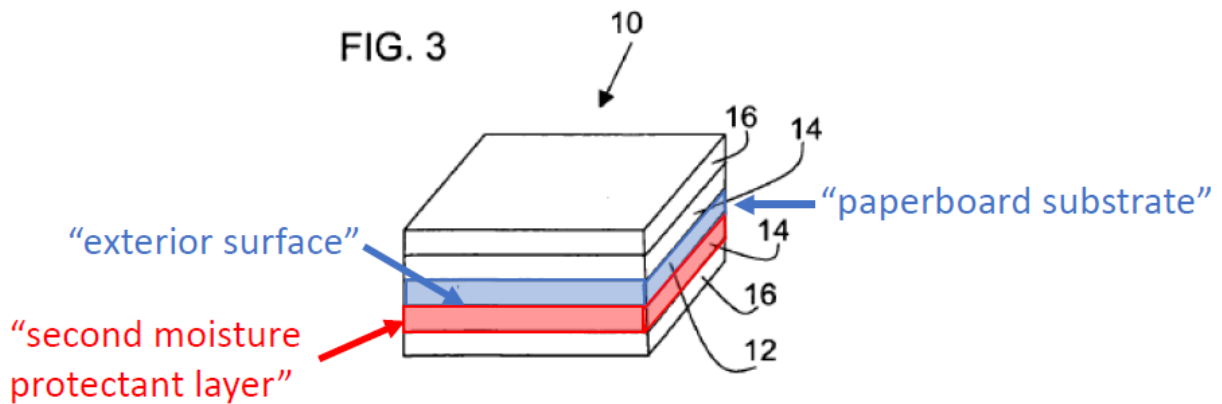

**Cleveland, FIG. 3\***

The *second moisture protectant layer* 14 highlighted above in Figure 3 is also comprised of either Eastar Bio or Ecoflex. EX1005, ¶[0032]; EX1006, 7. This highlighted layer is identical to the Eastar Bio/Ecoflex *moisture protectant layer* discussed above in Section VII.B.3, except that it is coated directly on the bottom (*exterior*) surface of substrate 12. See, e.g., EX1005, ¶¶[0003], [0009], [0013]-[0015], [0032]-[0033], Claim 15; EX1006, generally. Thus, for the same reasons discussed above in Section VII.B.3, the Eastar Bio/Ecoflex layer 14 of Figure 3 discloses a *second moisture protectant layer is coated directly only on said exterior surface of said paperboard substrate*, as claimed. EX1003, ¶93.

Accordingly, Cleveland discloses element [1.4].

**7. [1.5.1] “and comprising at least one biodegradable polyester polymer”**

Cleveland discloses this element. EX1003, ¶95. As explained, the bottom coextruded laminate 14, 16 (*second moisture protectant layer*) has the same

composition as the top coextruded laminate 14, 16 (*first moisture protectant layer*) detailed above: Eastar Bio/Ecoflex 14 and Biomax 16. *Supra* Sections VII.B.3-5; EX1005, ¶¶[0011]-[0012], [0029], [0032]; EX1006, 2-7. Thus, for the same reasons discussed above for element [1.3.1], Cleveland discloses element [1.5.1].

**8. [1.5.2] “wherein the second moisture protectant layer has a coat weight of from 5 to 30 lbs./3000 ft<sup>2</sup>”**

Cleveland discloses this element. EX1003, ¶96. As explained, the bottom coextruded laminate 14, 16 (*second moisture protectant layer*) has the same composition as the top coextruded laminate 14, 16 (*first moisture protectant layer*) detailed above. *Supra* Sections VII.B.3-5; EX1005, ¶¶[0011]-[0012], [0029]-[0032]; EX1006, 2-7. And, as explained above for element [1.3.2], Cleveland discloses the following total coat weights and individual Eastar Bio/Ecoflex 14 coat weight for the Figure 3 coextruded laminates 14, 16:

	<b>Total Coat Weight (lbs./3000 ft<sup>2</sup>)</b>	<b>80% Eastar Bio/Ecoflex (lbs./3000 ft<sup>2</sup>)</b>	<b>20% Eastar Bio/Ecoflex (lbs./3000 ft<sup>2</sup>)</b>	<b>Citation</b>
Min	10	8	2	EX1005, ¶[0032]; EX1006, 7.
Max	40	32	8	
Preferred	25	20	5	

*Supra* Section VII.B.5. Accordingly, for the same reasons discussed above for element [1.3.2], Cleveland discloses element [1.5.2] whether the entire bottom

coextruded laminate 14, 16—or only the Eastar Bio/Ecoflex portion 14—is viewed as the claimed *second moisture protectant layer*.

9. [1.6] “and is separate from the first moisture protectant layer coated on and directly adhered to said interior surface of said substrate”

Cleveland discloses this element. EX1003, ¶97. Specifically, as shown in Figure 3 below, Cleveland’s bottom biodegradable coextruded laminate 14, 16 (*second moisture protectant layer*) is separate from the first moisture protectant layer (top biodegradable coextruded laminate 14, 16) coated on and directly adhered to said interior surface (bottom surface) of said substrate (substrate 12):

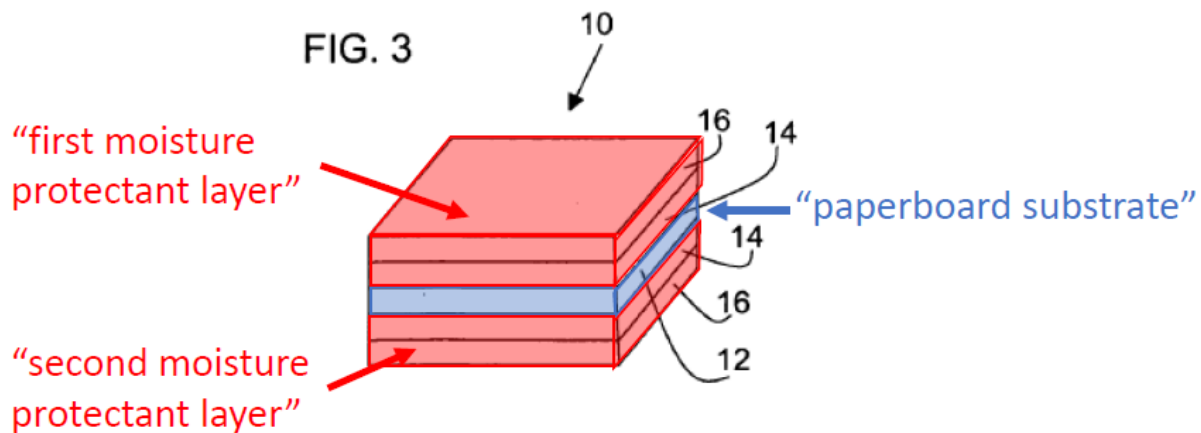

**Cleveland, FIG. 3\***

As explained, Figure 3 shows two separate biodegradable laminates (the *first* and *second moisture protectant layers*) coated on opposite sides of the paperboard substrate, separated by the paperboard substrate 12 itself. Cleveland discloses that the biodegradable laminates are coextruded onto “one flat surface of the substrate”

and “on the opposite flat surface of the substrate.” EX1005, ¶¶[0025]-[0032]; EX1006, 2, 7. It is also axiomatic that any paper cup would comprise an interior surface and an exterior surface, and any coatings applied to the two surfaces would be separate from each other. EX1003, ¶98.

Alternatively, when the Eastar Bio/Ecoflex layer 14 alone is the *second moisture protectant layer*, then for the same reasons explained above, it is *separate from the first moisture protectant layer* (top Eastar Bio/Ecoflex layer 14) *coated on and directly adhered to said interior surface* (bottom surface) *of said substrate* (substrate 12):

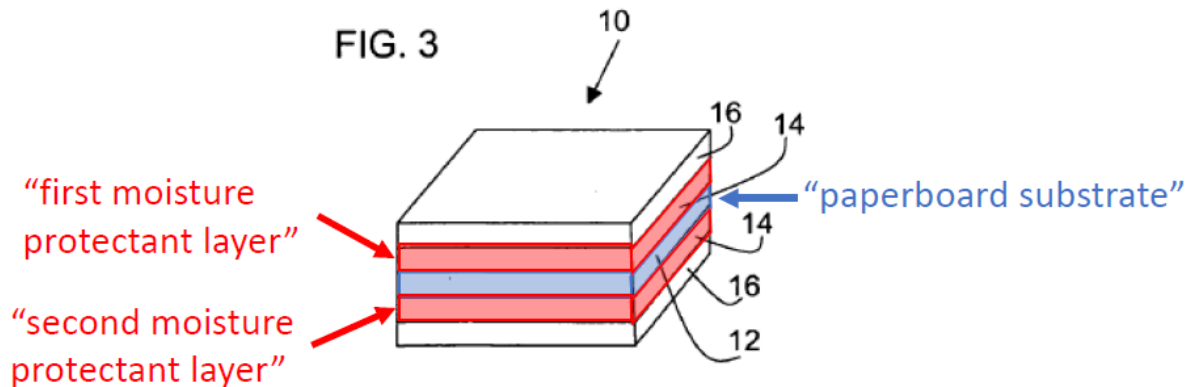

**Cleveland, FIG. 3\***

Thus, Cleveland discloses element [1.6].

Accordingly, Cleveland anticipates claim 1.

**C. Dependent Claim 2**

- 1. [2.1]: “The product according to claim 1, wherein the second moisture protectant layer further comprises from 5 to 20 percent by weight of at least one filler selected from the group consisting of calcium carbonate and starch.”**

As explained above, Cleveland anticipates the subject matter of claim 1. *Supra* Section VII.B. Moreover, Cleveland discloses the additional subject matter of claim 2 because, in Cleveland, *the second moisture protectant layer* (bottom biodegradable coextruded laminate 14, 16) *further comprises from 5 to 20 percent of at least one filler* (organic or inorganic filler) *selected from the group consisting of calcium carbonate* (calcium carbonate) *and starch* (starch). EX1003, ¶102.

Specifically, Cleveland discloses that “calcium carbonate may be added to any or all of the copolyester extrusions as a cost savings measure and to provide increase in the degradation rate by displacement of some of the biodegradable resin material.” EX1005, ¶[0034]; EX1006, 8. This means that calcium carbonate may be added to both the Eastar Bio/Ecoflex 14 and Biomax 16 layers, and therefore calcium carbonate may be added to both the *first* and *second moisture protectant layers*, whether they are defined as both Eastar Bio/Ecoflex 14 and Biomax 16 or only the Eastar Bio/Ecoflex layer 14.

Though Cleveland does not prescribe a specific percentage of filler to use, a POSITA would have known and appreciated that 5-20% by weight of calcium

carbonate and/or starch is a suitable amount to decrease costs without reducing the desirable features of a biodegradable laminate for a paper cup. EX1003, ¶105.

Accordingly, Cleveland anticipates claim 2.

**D. Dependent Claim 3**

- 1. [3.1] “The product according to claim 1, wherein the first moisture protectant layer further comprises from 5 to 20 percent by weight of at least one filler selected from the group consisting of calcium carbonate and starch.”**

Cleveland discloses the subject matter of claim 3 for the same reasons as explained above for claim 2, because Cleveland discloses the use of the same biodegradable laminate for both the interior and exterior surfaces of the paper substrate. EX1005, ¶[0032] (Ecoflex and Biomax are “coextruded... on one flat surface of the [paper] substrate... [and] on the opposite flat surface of the [paper] substrate.”); EX1006, 7; *supra* Section VII.C. Further, Cleveland discloses the use of fillers in “any or all of the copolyester extrusions.” EX1005, ¶[0034]; EX1006, 8.

Accordingly, Cleveland anticipates claim 3. EX1003, ¶¶108.

**E. Dependent Claim 11**

- 1. [11.1] “The product according to claim 3, wherein the first moisture protectant layer comprises from 5 to 20 percent by weight of calcium carbonate as the filler.”**

As explained above, Cleveland anticipates the subject matter of claim 3. *Supra* Section VII.D. Claim 11 only differs from claim 3 in that the filler must be calcium carbonate, not either calcium carbonate or starch. *Compare* EX1001 Claim 3 with

Claim 11. Because Cleveland discloses the use of calcium carbonate as a filler, Cleveland discloses or suggests Claim 11. *Supra* Section VII.C; EX1003, ¶109.

**VIII. GROUND 2: NAKAGAWA ALONE OR IN VIEW OF APPLICANT’S ADMITTED PRIOR ART RENDERS OBVIOUS CLAIMS 1-3, 11**

**A. Overview of Nakagawa**

Nakagawa is analogous art to the ’126 Patent because it relates to the same field of endeavor – biodegradable laminated paper cups. EX1003, ¶110; MPEP §2141.01(a).I (*citing Bigio*, 381 F.3d at 1325). Nakagawa is directed to “a paper cup using a biodegradable plastic that has the same performance as a conventional paper cup...and a manufacturing method thereof.” EX1008, Abstract. Nakagawa describes a paper cup that is laminated with “a biodegradable plastic” on either “one side or both sides” of the paper cup, where the biodegradable plastic’s “main component is a biodegradable microbially produced polyester or an aliphatic polyester.” *Id.*; *see also id.*, Claim 1.

Nakagawa explains that “microbially produced polyester is a general term for polyesters obtained by cultivating microorganisms such as bacteria or yeast, and isolating and purifying the polyester compounds that accumulate within the cells or culture medium, and is characterized by being derived from microorganisms.” *Id.*, ¶[0012]. Additionally, “aliphatic polyester refers to polyesters produced by chemical synthesis, in which the polymer consists only of carbon, hydrogen and oxygen atoms

and does not have a cyclic structure such as in aromatic polyesters.” *Id.* The biodegradable plastic of Nakagawa has the same, or better, biodegradability as paper, with the biodegradable plastic fully degrading after being buried in soil for three months. *Id.*, ¶[0035].

Figures 1 and 4, reproduced below, show Nakagawa’s paper cup using a biodegradable plastic:

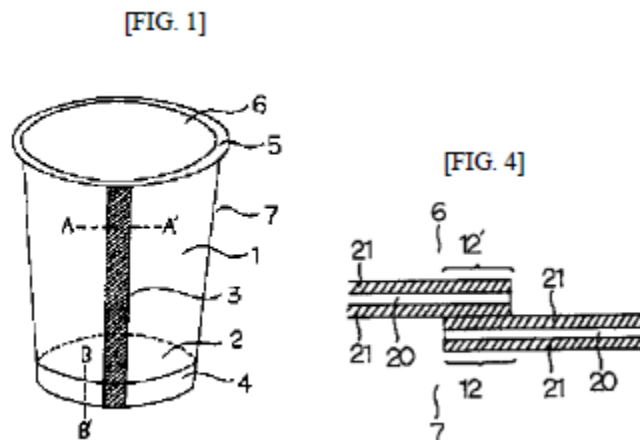

**Nakagawa, FIGS. 1 and 4**

Figure 1 shows “a perspective view illustrating one embodiment of the paper cup of the present invention,” while Figure 4 depicts a “cross-sectional view of the side surface sealing part illustrating one embodiment of the paper cup.” EX1008, [0040].

As shown in Figure 4, the biodegradable plastic 21 is laminated on both the inner surface 6 and outer surface 7 of the paper cup 20. Nakagawa states that in such embodiments where biodegradable plastic is laminated to both the outer and inner surfaces 6, 7, the paper cup can be sealed without the use of an adhesive because the

“[biodegradable] plastics 21 have heat-sealing properties” with “sufficient seal strength” to marry the paper with itself. EX1008, ¶[0022].

**B. Independent Claim 1**

**1. [1.pre] “A product in the form of a cup comprising a laminate forming moisture barriers, said laminate comprising:”**

To the extent the preamble is limiting, Nakagawa discloses or suggests this element. EX1003, ¶115. Specifically, Nakagawa discloses *a product in the form of a cup* (paper cup of Figure 1) *comprising a laminate forming moisture barriers* (waterproof laminated biodegradable plastic of Figure 4):

[FIG. 1]

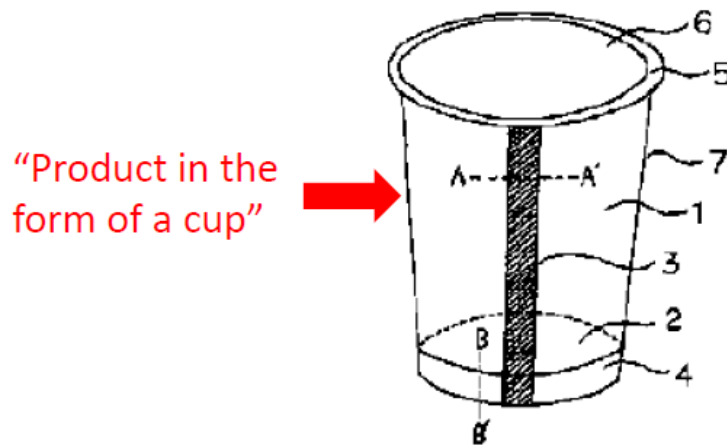

[FIG. 4]

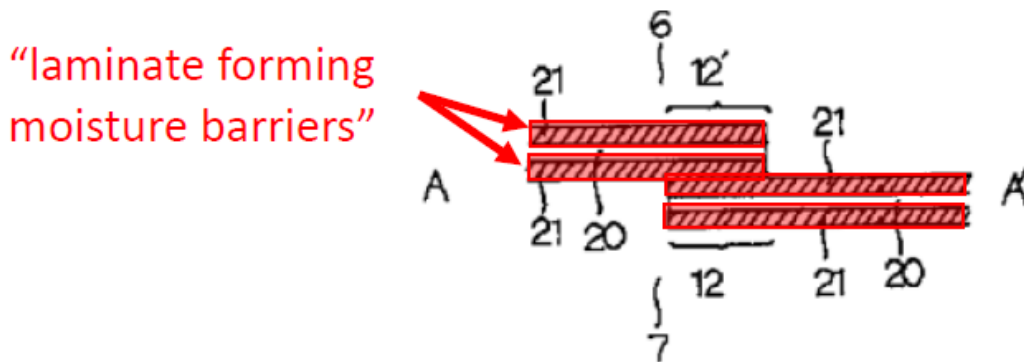

**Nakagawa, FIGS. 1\* and 4\***

Nakagawa describes “a paper cup using a biodegradable plastic that has the same performance as a conventional paper cup.” EX1008, Abstract. Paper cups, because they are used to contain “liquid or frozen liquid” contents “must be waterproof.” *Id.*, ¶[0002]. In order to make a paper cup waterproof, at least the “inner surface 6 of the cup is laminated with plastic.” *Id.* Nakagawa describes using a

biodegradable plastic to “lamine[...one or both sides of the paper [cup]” in order to make the cup waterproof. *Id.*, ¶[0013].

Accordingly, Nakagawa discloses or suggests element [1.pre].

**2. [1.1] “a paperboard substrate having a separate interior product facing surface and a separate exterior surface;”**

Nakagawa discloses or suggests this element. EX1003, ¶118. Specifically, Nakagawa discloses *a paperboard substrate (paper or paper cup) having a separate interior product facing surface and a separate exterior surface:*

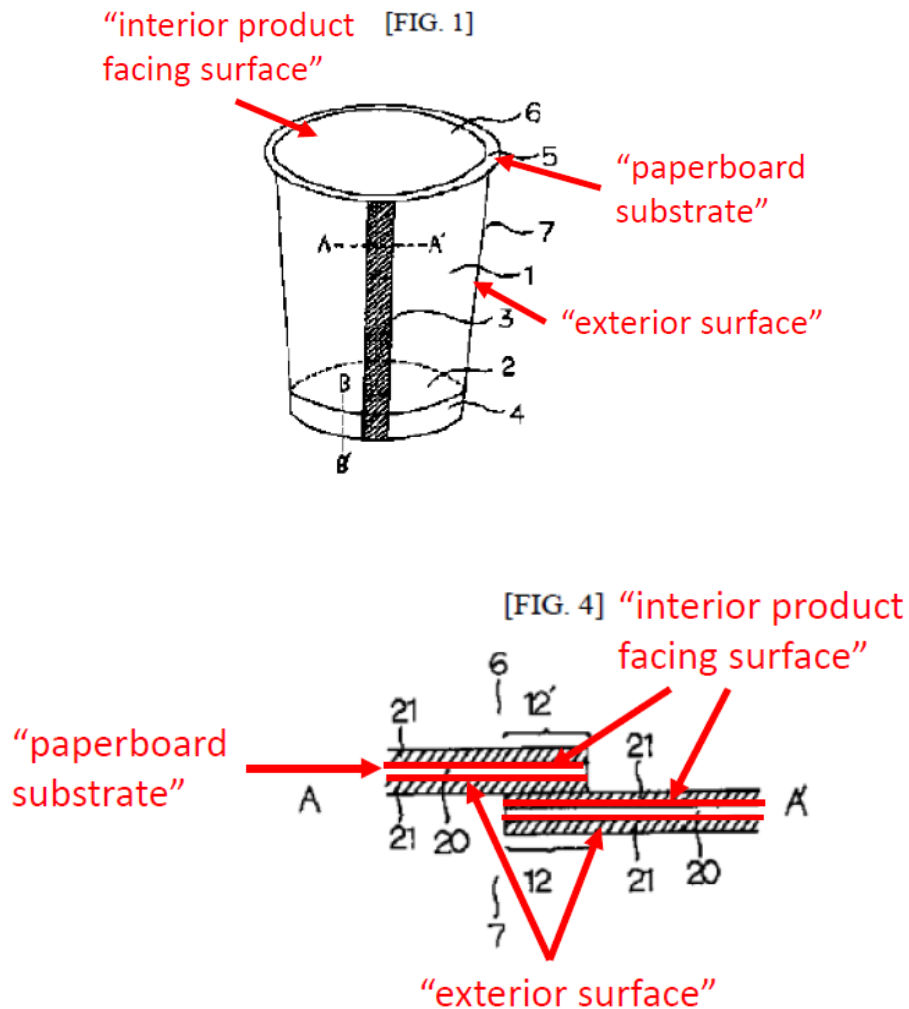

**Nakagawa, FIGS. 1\* & 4\***

Figure 1 above is a perspective view of a “paper cup.” EX1008, ¶[0040]. As highlighted in Figure 1 above, the disclosed paper cup has both the *interior product facing surface* and *separate exterior surface* of claim element [1.1]. EX1003, ¶119. It is also axiomatic that any paper cup would have separate interior and exterior surfaces. *Id.* Further, the interior surface in any cup would be *product facing* as it is the interior portion of the cup that holds the contents (i.e., liquids). *Id.*

Accordingly, Nakagawa discloses or suggests element [1.1].

3. [1.2] “a first moisture protectant layer is coated directly only on said interior surface of said paperboard substrate”

Nakagawa discloses or suggests this element. EX1003, ¶121. Specifically, the paper cup of Nakagawa has a *first moisture protectant layer* (biodegradable plastic 21) that is *coated* (laminated) *directly on said interior surface of said paperboard substrate* (paper or paper cup):

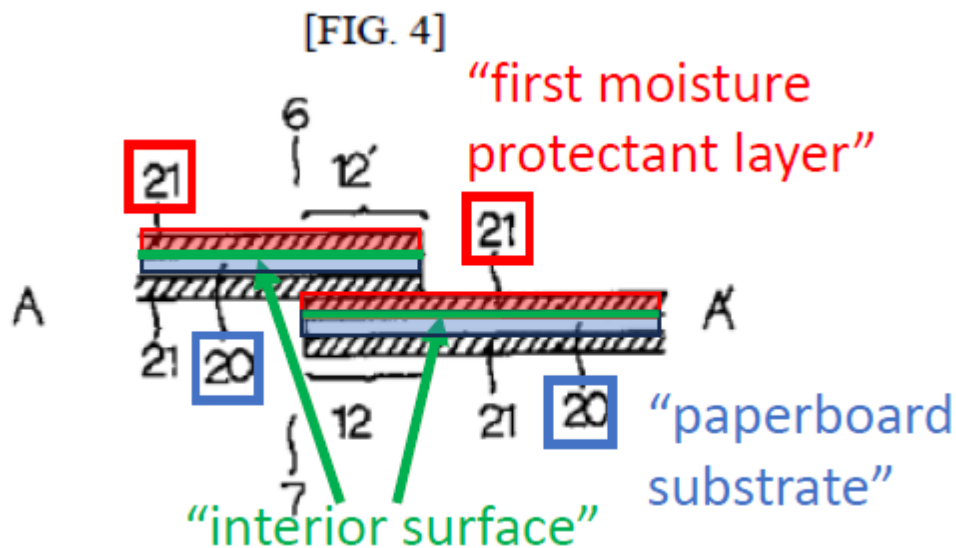

Nakagawa, FIG. 4\*

As highlighted in Figure 4 above, Nakagawa discloses that the biodegradable plastic 21 is laminated directly onto the paper 20 substrate—unlike the Kuusipalo reference cited during prosecution of the '126 Patent, which had an intervening adhesive layer. This is clear from the lack of any intermediary layers between the biodegradable plastic 21 and the paper 20. EX1003, ¶122.

Further, Nakagawa expressly discloses multiple times that the biodegradable plastic is laminated directly onto the paper. *See, e.g.*, EX1008, Abstract (“the plastic laminated on the paper”), ¶¶[0009] (“the present invention provides a paper cup made of paper that is laminated with plastic on at least one side or both sides of the paper”), [0010] (“biodegradable plastic...can be sealed to paper by a heat fusion method”; [0013] (“lamination may be performed using a method such as laminating a plastic film onto the paper, or melt extrusion coating the plastic onto the paper...By using this lamination method, a biodegradable plastic may be laminated on one or both sides of the paper.”). Moreover, Nakagawa discloses the use of a “manufacturing method...which uses melt extrusion coating *without the need for an adhesive.*” *Id.*, ¶[0013].

Accordingly, Nakagawa discloses or suggests element [1.2].

**4. [1.3.1] “and comprising at least one biodegradable polyester polymer”**

Nakagawa discloses or suggests this element. EX1003, ¶125. Specifically, Nakagawa discloses that the *first moisture protectant layer* (biodegradable plastic 21) is comprised of *at least one biodegradable polyester polymer* (biodegradable plastic or biodegradable microbially produced polyester or aliphatic polyester).

Nakagawa discloses that the “main component” of the biodegradable plastic that is laminated on one or both sides of the paper cup is either a “biodegradable

microbially produced *polyester* or an aliphatic *polyester*.” EX1008, Abstract, Claim 1. Nakagawa explains that microbially produced polyesters refers to “polyesters obtained by cultivating microorganisms such as bacteria or yeast, and isolating and purifying the polyester compounds that accumulate within the cells or culture medium.” *Id.*, ¶[0012]. Nakagawa lists the following as conventional prior art examples of microbially produced polyesters: “*polymers* of 3-hydroxybutyric acid, 4-hydroxybutyric acid, 3-hydroxyvaleric acid, and the like, and *copolymers* made up of two or more of these.” *Id.*, ¶[0010]. Aliphatic polyester refers to “polyesters produced by chemical synthesis, in which the *polymer* consists only of carbon, hydrogen and oxygen atoms and does not have a cyclic structure such as in aromatic polyesters.” *Id.*, ¶[0012]. Nakagawa lists the following as examples of aliphatic polyesters: “*polymers* of caprolactone, lactic acid, glycolic acid, and the like, and *copolymers* made up of two or more of these.” *Id.*, ¶[0010]. Thus, the biodegradable plastics disclosed by Nakagawa are *polyester polymers*. EX1003, ¶127.

The above identified *polyester polymers* disclosed by Nakagawa are *biodegradable*. *Id.*, ¶128. Nakagawa’s purpose, in part, was to provide a paper cup using a “biodegradable plastic having a biodegradability equal to or greater than that of paper.” EX1008, ¶[0010]. Nakagawa ran tests on various examples of

biodegradable plastics<sup>8</sup> laminated on paper cups to determine the biodegradability. *Id.*, ¶[0035]. The test involved burying the paper cups with laminated biodegradable plastics in soil for three months. *Id.* The results were that the biodegradable plastic “had completely disappeared...confirming that the paper cup of the present invention is biodegradable.” *Id.* Thus, Nakagawa’s polyester polymers are *biodegradable*. Further, Nakagawa’s polyester polymers meet the “degradable” definition used by Applicant during prosecution. *See* EX1002, 306 (“Degradability is defined as a >75-80% loss in molecular weight (MWT) in a relatively short amount of time (<9 months) due to exposure to oxygen, water, and microbes in the environment”). Moreover, as explained by Petitioner’s technical expert, Nakagawa’s polyester polymers satisfy ATSM D6868, cited by Applicant during prosecution of the ’126 Patent. EX1003, ¶129; EX1023.

Accordingly, Nakagawa discloses claim element [1.3.1].

---

<sup>8</sup> The example biodegradable plastics include: “a copolymer of 3-hydroxybutyric acid and 3-hydroxyvalerate” (referred to as “P (3HB-3HV)”); “polycaprolactone”; “poly-3-hydroxyvaleric acid” and “a mixture of...P (3HB-3HV) and “poly-3-hydroxyvaleric acid”. EX1008, ¶¶[0024]-[0034].

**5. [1.3.2] “wherein the first moisture protectant layer has a coat weight of from 5 to 30 lbs./3000 ft<sup>2</sup>”**

Nakagawa discloses or suggests this element. EX1003, ¶131. Alternatively, Nakagawa and the admitted prior art disclosed by the '126 Patent (“Applicant’s Admitted Prior Art”) render this element obvious. *Id.*

**a. Nakagawa discloses coat weights of 5 to 30 lbs./3000 ft<sup>2</sup>**

Nakagawa discloses or suggests that *the first moisture protectant layer* (biodegradable plastic 21) *has a coat weight of from 5 to 30 lbs./3000 ft<sup>2</sup>* (lamine thickness of 15  $\mu\text{m}$  or 30  $\mu\text{m}$ ). Nakagawa discloses five examples of paper cups with biodegradable plastic coated on the paper substrate. EX1008, ¶¶[0024]-[0034]. For each example, the specific polymers and the thickness of the coat are disclosed. *Id.* A POSITA would recognize that the disclosed polymers have a given density, and therefore the coat weight can be calculated by determining the total volume of polymer used (thickness multiplied by 3000 ft<sup>2</sup>) and multiplying the volume by the polymer’s known density. EX1003, ¶132. The result is the total weight of polymer that was coated on 3000 ft<sup>2</sup> of paper substrate—i.e., the coat weight. *Id.*

For example, Nakagawa discloses a paper cup laminated with “a copolymer of 3-hydroxybutyric acid and 3-hydroxyvalerate (hereinafter indicated as P (3HB-3HV)) (manufactured by ICI, UK: ‘Biopole’, (hydroxyvalerate content: 10%))” at a “thickness of 30  $\mu\text{m}$ .” EX1008, ¶[0024]. This copolymer has a density of 1.25 g/cm<sup>3</sup>

at room temperature. EX1003, ¶133; EX1024, 4. With these known parameters, the coat weight is easily calculated to be 23.04 lbs./3000 ft<sup>2</sup>—falling squarely within the claimed range. EX1003, ¶133.

Accordingly, Nakagawa discloses or suggests element [1.3.2].

**b. Alternatively, Applicant’s Admitted Prior Art discloses coat weights of 5 to 30 lbs./3000 ft<sup>2</sup>**

The ’126 Patent admits that the use of a *coat weight of 5 to 30 lbs./3000 ft<sup>2</sup>* (coat weight of 0.5-1.5 mils or 7.2-21.6 lbs./3000 ft<sup>2</sup>) for polymer lamination of paper cups already existed in the prior art. EX1003, ¶135. Specifically, in the “Description of the Related Art,” the ’126 Patent states that “[p]aper-based laminates for food service uses” such as cups are typically coated with “low-density polyethylene (LDPE) or other similar polymers.” EX1001, 1:52-62. Further, the ’126 Patent admits that it was “common” to use a “coat weight of 0.5-1.5 mils (7.2-21.6 lbs./3000 ft<sup>2</sup>).” *Id.*

Accordingly, the Applicant’s Admitted Prior Art discloses the use of a *coat weight of 5 to 30 lbs./3000 ft<sup>2</sup>*.

**c. Nakagawa-’126 Patent’s admitted prior art Combination**

To modify Nakagawa to embody element [1.3.2], a POSITA would have modified Nakagawa’s *first moisture protectant layer* (biodegradable plastic 21) to have a *coat weight of 5 to 30 lbs./3000 ft<sup>2</sup>* (coat weight of 0.5-1.5 mils or 7.2-21.6

lbs./3000 ft<sup>2</sup>) as disclosed in the '126 Patent's recitation of the prior art. EX1003, ¶137. As coat weight merely defines the thickness of the plastic layer to be laminated on the paper substrate, modifying the thickness of the biodegradable plastic layer disclosed in Nakagawa to be the thickness of the coat weight as disclosed in the Applicant's Admitted Prior Art would practice element [1.3.2].

**d. Rationale to Combine Nakagawa and the prior art admitted by the '126 Patent**

A POSITA would have had motivation to modify Nakagawa to incorporate the *coat weight of 5 to 30 lbs./3000 ft<sup>2</sup>* (coat weight of 0.5-1.5 mils or 7.2-21.6 lbs./3000 ft<sup>2</sup>) as disclosed in the Applicant's Admitted Prior Art. EX1003, ¶138. Petitioner addresses two examples below.

**Conventional coat weight for paper cups:** As stated in Nakagawa, the goal of the disclosed invention is “to provide a paper cup using a biodegradable plastic that has the same performance as a conventional paper cup.” EX1008, ¶[0008]. Although biodegradable plastics have certain differing properties from traditional plastics used on paper cups –such as polyethylene<sup>9</sup>—Nakagawa discloses that the lamination of the biodegradable plastic on the paper can be accomplished using the

---

<sup>9</sup> See EX1008, ¶[0002] (describing conventional paper cups as being “laminated with plastic – generally polyethylene.”)

same “ordinary method.” *Id.*, ¶[0013]. As Nakagawa prescribes no specific coat weight, a POSITA would have been motivated to use ordinary/conventional methods of biodegradable lamination—including the use of conventional coat weights. EX1003, ¶139. And the ’126 Patent states that in the prior art, the common coat weight used for paper-based food service products—including paper cups—is “7.2-21.6 lbs./3000 ft<sup>2</sup>.” EX1001, 1:52-62. Accordingly, given Nakagawa’s silence on a specific coat weight, a POSITA would have been motivated to incorporate the coat weights disclosed in the prior art admitted in the ’126 Patent into Nakagawa. EX1003, ¶139.

**Nakagawa describes the use of varying thicknesses of lamination:**

Nakagawa does not focus on coat weight, and thus does not specifically prescribe a required range of coat weights for its biodegradable plastics. Nakagawa, however, does describe various examples of embodiments of paper cups laminated with different biodegradable plastics at different thicknesses—which directly correlates with coat weight. EX1008, ¶¶[0024]-[0034] (describing various examples with biodegradable plastic laminate thicknesses of 15µm or 30µm). With no prescribed coat weight, and instead examples of varying laminate thicknesses/coat weights, POSITA would have understood that other laminate thicknesses could be used. Thus, a POSITA would have been motivated to try various thicknesses and therefore

various coat weights, including those commonly used in then-existing paper cups as described in the prior art admitted in the '126 Patent. EX1003, ¶140.

**i. *KSR* Rationale: Obvious to try—Choosing from a Finite Number of Identified, Predictable Solutions, with a Reasonable Expectation of Success**

Petitioner's proposed modification of Nakagawa would have been obvious to try, as there are only a finite number of solutions for coat weight and there would have been a reasonable expectation that the coat weight discussed by the '126 Patent would have been successful. *KSR Int'l Co. v. Teleflex Inc.*, 550 U.S. 398, 417 (2007); MPEP §2143.I.(E) (identifying factors for the "obvious to try" rationale); EX1003, ¶141. Petitioner analyzes each relevant factor for the obvious to try rationale below:

**Recognized problem or need in the art:** Plastics, whether biodegradable or not, must be laminated onto food service paper products at a sufficient thickness in order to make the paper product moisture proof. EX1003, ¶142; EX1008, ¶[0002]. This is particularly true for paper cups, as they must be able to hold liquid without the liquid seeping into the paper substrate, which would ultimately cause leakage and the deterioration of the paper cup. EX1003, ¶142; EX1008, ¶[0002]. The thickness of the laminated plastic directly corresponds to coat weight, and can be expressed in multiple different units. One such industry standard is lbs./3000 ft<sup>2</sup>. EX1003, ¶142. As Nakagawa does not directly discuss what coat weight range

would be acceptable for the disclosed biodegradable plastics, a POSITA would recognize that there is a need to determine an appropriate coat weight. *Id.*

**Finite number of identified, predictable potential solutions:** There are only a finite number of potential solutions for coat weights of plastics on paper food service products, such as paper cups. EX1003, ¶143. Too low of a coat weight will result in the plastic laminate being too thin to sufficiently waterproof the paper product. *Id.* Too high of a coat weight would be cost inefficient—using more plastic product than is necessary—and could cause problems with lamination, make the product less degradable, or feel strange in the customer’s hand, or other unwanted side effects. *Id.* For traditional, non-biodegradable plastics, the ’126 Patent states that coat weights are generally between 7.2-21.6 lb/3000 ft<sup>2</sup>. EX1001, 1:40-62. This is because coat weights below 7.2 lb/3000 ft<sup>2</sup> risk failing to adequately waterproof the paper product, while coat weights above 21.6 lb/3000 ft<sup>2</sup> have diminishing improvement in waterproofing. *See id.*; EX1003, ¶143. For the above reasons, a POSITA would recognize that there are only a finite number of potential coat weights for the biodegradable plastics disclosed in Nakagawa.

**POSITA could have pursued known potential solutions with reasonable expectation of success:** Nakagawa discloses that “the method for laminating the biodegradable plastic and the paper may be an ordinary method used for laminating plastic and paper.” EX1008, ¶[0013]. Specifically, Nakagawa discloses “extrusion

coating” the biodegradable laminate onto the paper substrate. *Id.* Therefore, a POSITA would have recognized that the ordinary coat weights used for laminating plastic and paper – and more specifically the coat weights used in extrusion coating, including the extrusion coat weights disclosed in the ’126 Patent’s discussion of the prior art<sup>10</sup> – could be tested with a reasonable expectation of success.

Accordingly, Nakagawa and the Applicant’s Admitted Prior Art render obvious element [1.3.2].

**6. [1.4] “a second moisture protectant layer is coated directly only on said exterior surface of said paperboard substrate”**

Nakagawa discloses or suggests this element. EX1003, ¶146. Specifically, Nakagawa discloses *a second moisture protectant layer* (biodegradable plastic 21) that is *coated directly only on said exterior surface of said paperboard substrate* (paper 20 or paper cup):

---

<sup>10</sup> “Paper-based laminates for food service uses are typically *extrusion coated* with low-density polyethylene (LDPE)...LDPE *coat weights* of 0.5-1.5 mils (**7.2-21.6 lb/3000 ft<sup>2</sup>**) are common.” EX1001, 1:34-44.

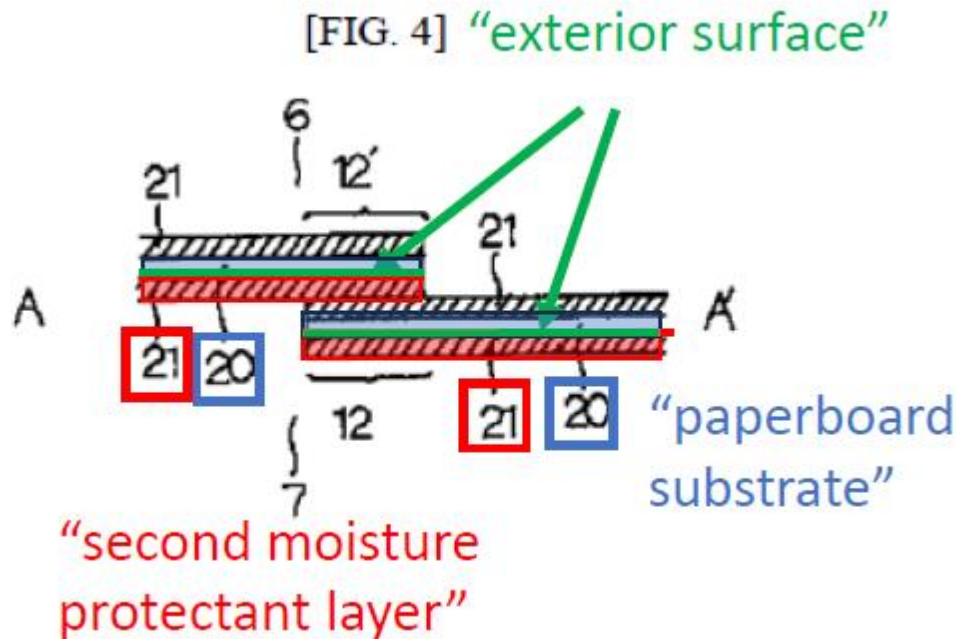

**Nakagawa, FIG. 4\***

As highlighted in Figure 4, the biodegradable plastic 21 is laminated on the exterior surface. *See also* EX1008, ¶[0013] (“a biodegradable plastic may be laminated on one or **both sides of the paper**.”). Moreover, it is clear that the plastic layer is laminated or coated directly on the exterior surface of the paper 20 with no intervening layers or materials. *Id.*, ¶[0010] (“biodegradable plastic...can be sealed to paper by a heat fusion method.”), [0013] (“biodegradable plastic” is “laminated on one or both sides of the paper.”). When the biodegradable plastic is laminated on both the exterior and interior surfaces, the plastics can be heated and used to seal the cup without using an additional adhesive. *Id.*, ¶[0022]. Moreover, Nakagawa

discloses the use of a “manufacturing method...which uses melt extrusion coating *without the need for an adhesive.*” *Id.*, ¶[0013].

Accordingly, Nakagawa discloses or suggests element [1.4].

**7. [1.5.1] “and comprising at least one biodegradable polyester polymer”**

Nakagawa discloses this element for the same reasons as claim [1.3.1]. EX1003, ¶149. Nakagawa discloses that the same “biodegradable plastic may be laminated on one or both sides of the paper.” EX1008, ¶[0013] (“when laminating on both sides, different types of biodegradable plastics *may* be used.”) Thus, for the reasons explained above in Section VIII.B.4., Nakagawa discloses element [1.5.1].

**8. [1.5.2] “wherein the second moisture protectant layer has a coat weight of from 5 to 30 lbs./3000 ft<sup>2</sup>”**

Nakagawa discloses this element for the same reasons as claim element [1.3.2], as discussed above in Sections VIII.B.5.a. Alternatively, Nakagawa and Applicant’s Admitted Prior Art render this element obvious for the same reasons as claim element [1.3], as discussed above in Section VIII.B.5.b-d.

Claim elements [1.3.2] and [1.5.2] are substantively identical except that element [1.5.2] refers to the second moisture protectant layer and element [1.3.2] refers to the first moisture protectant layer. *Compare* claim element [1.3.2] *with* claim element [1.5.2]; EX1003, ¶152. Nakagawa does not disclose the use of different coat weights for the biodegradable plastic 21 laminates depending on

whether they are laminated to the interior or exterior surface. Thus, for the same reasons explained in Section VIII.B.5.a, Nakagawa discloses the *second moisture protectant layer having a coat weight of 5 to 30 lbs./3000 ft<sup>2</sup>*. Alternatively, for the same reasons it would have been obvious to a POSITA to try the coat weights disclosed in the Applicant's Admitted Prior Art for the first moisture protectant layer, it would have been obvious to a POSITA to try those same known coat weights for the second moisture protectant layer. EX1003, ¶152; Section VIII.b-d.

Accordingly, Nakagawa, or alternatively Nakagawa in view of Applicant's Admitted Prior Art, render obvious element [1.5.2].

**9. [1.6] “and is separate from the first moisture protectant layer coated on and directly adhered to said interior surface of said substrate”**

Nakagawa discloses or suggests this element. EX1003, ¶154. Specifically, Nakagawa discloses that the *second moisture protectant layer* (biodegradable plastic 21) *is separate from the first moisture protectant layer* (biodegradable plastic 21):

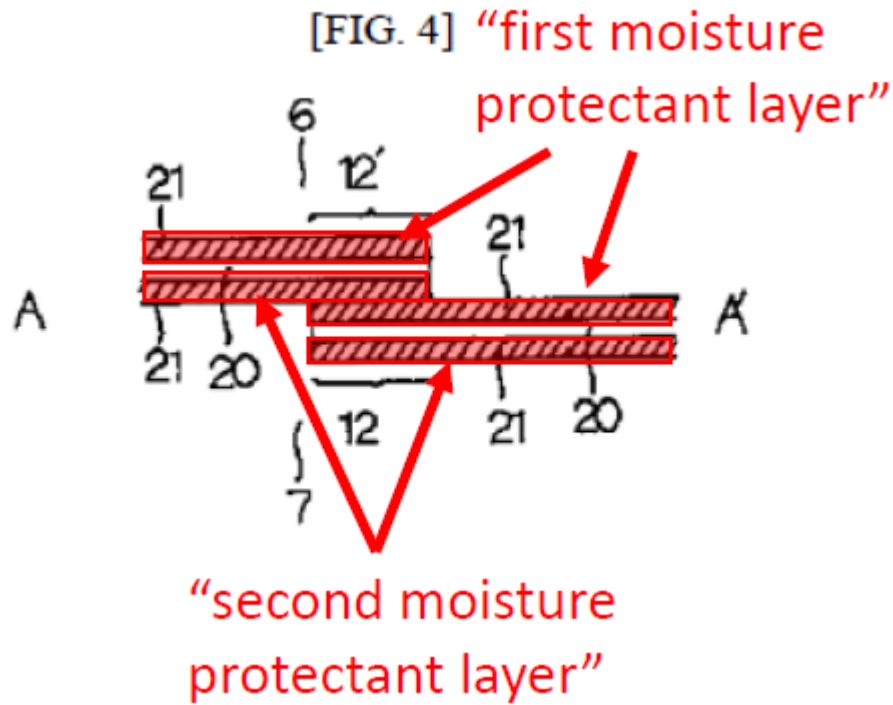

**Nakagawa, FIG. 4\***

As highlighted above in Figure 4, the second moisture protectant layer is separated from the first moisture protectant layer by the paper 20. Through the ordinary method of laminating, one side of the paper 20 (e.g., the side forming the interior surface) is laminated with a layer of biodegradable plastic, while the other side of the paper 20 (e.g., the side forming the exterior surface) is separately laminated with a layer of biodegradable plastic. EX1003, ¶155. The two biodegradable plastic layers are necessarily separate, as not only are they on

opposing sides of the paper substrate, but the two biodegradable plastic layers may be of “different types of biodegradable plastics.” EX1008, ¶[0013].<sup>11</sup>

Accordingly, Nakagawa discloses or suggests this element.

**C. Dependent Claim 2**

- 1. [2.1]: “The product according to claim 1, wherein the second moisture protectant layer further comprises from 5 to 20 percent by weight of at least one filler selected from the group consisting of calcium carbonate and starch.”**

As explained above, Nakagawa—or the combination of Nakagawa and the Applicant’s Admitted Prior Art—renders obvious the subject matter of claim 1. *Supra* Section VIII.B. Moreover, Nakagawa discloses or suggests the additional subject matter of claim 2 because, in Nakagawa, *the second moisture protectant layer* (biodegradable plastic) *further comprises from 5 to 20 percent (50% or less) of at least one filler* (non-degradable additives, polymers, or non-degradable substance) *selected from the group consisting of calcium carbonate and starch.*

Nakagawa discloses that the biodegradable plastics can be used in a mixture that contains “various non-degradable additives, polymers, and the like.” EX1008,

---

<sup>11</sup> Like all paper cups, the cup disclosed in Nakagawa includes a sealing part where the paper cup overlaps itself. In this limited portion, the two plastic layers touch. The two layers are still separate in this sealing portion. EX1003, ¶155, n.11.

¶[0011]. The amount of filler (i.e., additive) added must have a “weight ratio [of] 50% or less,” otherwise the biodegradability will be significantly reduced and it can “cause problems in processing.” *Id.* As “50% or less” encompasses the claimed range of “5 to 20 percent,” this portion of claim 2 is disclosed by Nakagawa. *In re Peterson*, 315 F.3d 1325, 1329 (Fed. Cir. 2003). And although Nakagawa does not explicitly disclose that the filler could be calcium carbonate, a POSITA would have known that calcium carbonate is a non-degradable additive that is commonly used as a filler in biodegradable plastics. EX1003, ¶158.

Accordingly, Nakagawa – or Nakagawa and the Applicant’s Admitted Prior Art – renders obvious claim 2.

#### **D. Dependent Claim 3**

- 1. [3.1] “The product according to claim 1, wherein the first moisture protectant layer further comprises from 5 to 20 percent by weight of at least one filler selected from the group consisting of calcium carbonate and starch.”**

Nakagawa – or the combination of Nakagawa and Applicant’s Admitted Prior Art – renders obvious the subject matter of claim 3 for the same reasons as explained above for claim 2. This is because claim 3 only differs from claim 2 in that claim 2 pertains to the *second moisture protectant layer*, while claim 3 pertains to the *first moisture protectant layer*. Compare Claim 2 with Claim 3. Nakagawa does not disclose that different biodegradable plastics must be used for the first and second

moisture protectant layers, much less that the filler composition must be different. To the contrary, Nakagawa teaches that the “biodegradable plastic may be laminated on...both sides of the paper” and that “different types of biodegradable plastics *may* be used on both sides” – meaning that Nakagawa does not require different plastics to be used. EX1008, ¶[0013]. Thus, a POSITA would understand that for the same reasons explained above for claim 2, calcium carbonate could be used as the non-degradable additive in the *first moisture protectant layer* as disclosed by Nakagawa.

Accordingly, Nakagawa – or Nakagawa and the Applicant’s Admitted Prior Art – renders obvious claim 3.

**E. Dependent Claim 11**

- 1. [11.1] “The product according to claim 3, wherein the first moisture protectant layer comprises from 5 to 20 percent by weight of calcium carbonate as the filler.”**

As explained above, Nakagawa – or the combination of Nakagawa and the prior art discussed and recognized by the ’126 Patent – renders obvious the subject matter of claim 3. *Supra* Section VIII.D. Claim 11 only differs from claim 3 in that the filler must be calcium carbonate, not either calcium carbonate or starch. *Compare* Claim 3 *with* Claim 11. Because a POSITA would have known that calcium carbonate is a non-degradable additive that is commonly used as a filler in biodegradable plastics, Nakagawa discloses or suggests claim 11. EX1003, ¶162.

**IX. GROUND 3: NAKAGAWA IN VIEW OF TANNER RENDERS  
OBVIOUS CLAIMS 1-3, 11**

**A. Overview of Tanner**

Tanner is analogous art to the '126 Patent and Nakagawa because it relates to the same field of endeavor – biodegradable laminated paper cups. EX1003, ¶163; MPEP §2141.01(a).I (*citing Bigio*, 381 F.3d at 1325). Tanner relates to a “biodegradable paperboard-based package” for liquid and non-liquid food products. EX1009, Abstract. Tanner’s paperboard-based package comprises a “paperboard substrate,” a layer of “polyethylene extrusion coated onto the product-contact side of the paperboard,” and a layer of “a biodegradable thermoplastic material extrusion coated on the exterior of the paperboard.” *Id.*, 2:16-24. The paperboard-based package may then be converted into packages such as “paper-based cups”. *Id.*

**B. Independent Claim 1**

- 1. [1.pre] “A product in the form of a cup comprising a laminate forming moisture barriers, said laminate comprising:”**

To the extent the preamble is limiting, Nakagawa discloses or suggests this element for the same reasons discussed in Section VIII.B.1.

- 2. [1.1] “a paperboard substrate having a separate interior product facing surface and a separate exterior surface;”**

Nakagawa discloses or suggests this element for the same reasons discussed in Section VIII.B.2.

**3. [1.2] “a first moisture protectant layer is coated directly only on said interior surface of said paperboard substrate”**

Nakagawa discloses or suggests this element for the same reasons discussed in Section VIII.B.3.

**4. [1.3.1] “and comprising at least one biodegradable polyester polymer”**

Nakagawa discloses or suggests this element for the same reasons discussed in Section VIII.B.4.

**5. [1.3.2] “wherein the first moisture protectant layer has a coat weight of from 5 to 30 lbs./3000 ft<sup>2</sup>”**

Nakagawa and Tanner render this element obvious. Specifically, Tanner discloses the use of *a coat weight of from 5 to 30 lbs./3000 ft<sup>2</sup>* (coating weight of 7 to 20 lbs./3000 ft<sup>2</sup>). It would have been obvious to modify the biodegradable plastic layer of Nakagawa to have a coat weight as disclosed in Tanner.

**a. Tanner discloses coat weights of 5 to 30 lbs./3000 ft<sup>2</sup>**

Tanner discloses the use of *a coat weight of 5 to 30 lbs./3000 ft<sup>2</sup>* (coating weight of 7 to 20 lbs./3000 ft<sup>2</sup>) for a biodegradable polymer resin laminated on paper cups. EX1003, ¶169. Tanner discloses a “biodegradable paper-board-based package for various food products.” EX1009, Abstract. One disclosed food product package is a “paper-based cup.” *Id.*, 2:21-24. “A preferred embodiment” disclosed by Tanner comprises a “biodegradable two-side coated paperboard-based laminate structure.” *Id.*, 2:55-68. The paper board substrate is coated with “a degradable polymer resin

[] in a coating weight of 7 to 20 lbs., preferably 9 lbs.,” whereby the “weights given for particular laminate layers...are expressed in pounds per 3,000 square feet.” *Id.* Thus, Tanner discloses laminating a biodegradable polymer onto a paper-cup substrate at a coat weight of between 7 to 20 lbs./3000 ft<sup>2</sup>—falling entirely within the claimed range. *See Titanium Metals*, 778 F.2d at 782 (“It is also an elementary principle of patent law that when, as by a recitation of ranges or otherwise, a claim covers several compositions, the claim is anticipated if one of them is in the prior art.”) (citation omitted).

Accordingly, Tanner discloses the use of a *coat weight of 5 to 30 lbs./3000 ft<sup>2</sup>*.

**b. Nakagawa-Tanner Combination**

To modify Nakagawa to embody element [1.3.2], a POSITA would have modified Nakagawa’s *first moisture protectant layer* (biodegradable plastic) to have a *coat weight of 5 to 30 lbs./3000 ft<sup>2</sup>* (coating weight of 7 to 20 lbs./3000 ft<sup>2</sup>) as disclosed in Tanner. EX1003, ¶171. As coat weight merely defines the thickness of the plastic layer to be laminated on the paper substrate, modifying the thickness of the biodegradable plastic layer disclosed in Nakagawa to be the thickness of the coat weight as disclosed in Tanner would practice element [1.3.2].

**c. Rationale to Combine Nakagawa and Tanner**

A POSITA would have had motivation to modify Nakagawa to incorporate the *coat weight of 5 to 30 lbs./3000 ft<sup>2</sup>* (coating weight of 07 to 20 lbs./3000 ft<sup>2</sup>) as disclosed by Tanner. EX1003, ¶172. Petitioner addresses two examples below.

**Conventional coat weight for paper cups:** As stated in Nakagawa, the goal of the disclosed invention is “to provide a paper cup using a biodegradable plastic that has the same performance as a conventional paper cup.” EX1008, ¶[0008]. Tanner similarly has the goal of providing a “paperboard-based...package which will biodegrade...and be structurally strong enough to hold food products in an acceptable manner.” EX1009, 1:66-2:2. Although biodegradable plastics have certain differing properties from traditional plastics used on paper cups –such as polyethylene<sup>12</sup>—Nakagawa discloses that the lamination of the biodegradable plastic on the paper can be accomplished using the same “ordinary method” of “extrusion coating.” EX1008, ¶[0013]. Likewise, Tanner discloses that the biodegradable polymer is “extrusion coated” onto the paperboard substrate. EX1009, 2:18-40, 3:56-60. As no specific coat weight is prescribed by Nakagawa, a

---

<sup>12</sup> EX1008, ¶[0002] (describing conventional paper cups as being “laminated with plastic – generally polyethylene.”)

POSITA would have been motivated to use ordinary/conventional methods of lamination – including the use of known coat weights used in extrusion coating of paper-based cups. Moreover, because both Tanner and Nakagawa disclose extrusion coating of biodegradable polymers onto a paperboard substrate for paper cups, a POSITA would have been motivated to incorporate the coat weights disclosed in Tanner into Nakagawa. EX1003, ¶173.

**Nakagawa describes the use of varying thicknesses of lamination:** Nakagawa does not prescribe a required range of coat weights for its biodegradable plastics. Nakagawa does describe various examples of embodiments of paper cups laminated with different biodegradable plastics at different thicknesses. EX1008, ¶¶[0024]-[0034] (describing various examples with biodegradable plastic laminate thicknesses of 15µm or 30µm). As explained above, the thickness of the biodegradable plastic laminate is directly proportional to the coat weight. *See* Section VIII.B.4.b. Therefore, a POSITA would have recognized that different thicknesses/coat weights could be used for the paper cup disclosed by Nakagawa. Thus, a POSITA would have been motivated to try various coat weights, including the coat weights for biodegradable polymers disclosed by Tanner.

**i. *KSR* Rationale: Obvious to try – Choosing from a Finite Number of Identified, Predictable Solutions, with a Reasonable Expectation of Success**

Petitioner’s proposed modification of Nakagawa would have been obvious to try, as there are only a finite number of solutions for coat weight and there would have been a reasonable expectation that the coat weights disclosed by Tanner would have been successful. *KSR*, 550 U.S. at 417; MPEP §2143.I.(E) (identifying factors for the “obvious to try” rationale); EX1003, ¶175. Petitioner analyzes each relevant factor for the obvious to try rationale below:

**Recognized problem or need in the art:** *See* discussion in Section VIII.B.4.e.i.

**Finite number of identified, predictable potential solutions:** *See* discussion in Section VIII.B.4.e.i.

**POSITA could have pursued known potential solutions with reasonable expectation of success:** Nakagawa discloses that “the method for laminating the biodegradable plastic and the paper may be an ordinary method used for laminating plastic and paper,” specifically “extrusion coating.” EX1008, ¶[0013]. Therefore, a POSITA would have recognized that the coat weights used for extrusion coating biodegradable polymers onto paper substrates – including the coat weights disclosed in Tanner – could be tested with a reasonable expectation of success. More

particularly, because Nakagawa and Tanner disclose paper cups with biodegradable polymers extrusion coated onto the paper substrate, a POSITA would have a reasonable expectation that the coat weight of Tanner could be used successfully with Nakagawa.

Accordingly, Nakagawa and Tanner render obvious element [1.3.2].

6. **[1.4] “a second moisture protectant layer is coated directly only on said exterior surface of said paperboard substrate”**

Nakagawa discloses or suggests this element for the same reasons discussed in Section VIII.B.6.

7. **[1.5.1] “and comprising at least one biodegradable polyester polymer”**

Nakagawa discloses or suggests this element for the same reasons discussed in Section VIII.B.7.

8. **[1.5.2] “wherein the second moisture protectant layer has a coat weight of from 5 to 30 lbs./3000 ft<sup>2</sup>”**

Nakagawa and Tanner render this element obvious for the same reasons as claim element [1.3.2], as discussed above in Section IX.B.5, because the claim elements are substantively identical except that element [1.5.2] refers to the second moisture protectant layer and element [1.3.2] refers to the first moisture protectant layer. *Compare* claim element [1.3.2] *with* claim element [1.5.2]; EX1003, ¶182. Nakagawa discloses that the same “biodegradable plastic may be laminated on one

or both sides of the paper.” EX1008, ¶[0013] (“when laminating on both sides, different types of biodegradable plastics *may* be used.”)

Nakagawa does not disclose the use of different coat weights for the biodegradable plastic 21 laminates depending on whether they are laminated to the interior or exterior surface. Thus, for the same reasons it would have been obvious to a POSITA to try the coat weights disclosed in Tanner for the first moisture protectant layer, it would have been obvious to a POSITA to try those same known coat weights for the second moisture protectant layer. EX1003, ¶183; Section IX.B.5.

Accordingly, Nakagawa and Tanner render obvious element [1.5.2].

9. **[1.6] “and is separate from the first moisture protectant layer coated on and directly adhered to said interior surface of said substrate”**

Nakagawa discloses or suggests this element for the same reasons discussed in Section VIII.B.9. EX1003, ¶185.

### **C. Dependent Claim 2**

1. **[2.1]: “The product according to claim 1, wherein the second moisture protectant layer further comprises from 5 to 20 percent by weight of at least one filler selected from the group consisting of calcium carbonate and starch.”**

As explained above, the combination of Nakagawa and Tanner renders obvious the subject matter of claim 1. *Supra* Section IX.B. Moreover, Nakagawa

discloses or suggests the additional subject matter of claim 2 for the same reasons discussed in Section VIII.C.

Accordingly, the combination of Nakagawa and Tanner renders obvious claim 2.

**D. Dependent Claim 3**

- 1. [3.1] “The product according to claim 1, wherein the first moisture protectant layer further comprises from 5 to 20 percent by weight of at least one filler selected from the group consisting of calcium carbonate and starch.”**

As explained above, the combination of Nakagawa and Tanner renders obvious the subject matter of claim 1. *Supra* Section IX.B. Moreover, Nakagawa discloses or suggests the additional subject matter of claim 2 for the same reasons discussed in Section VIII.C.

Accordingly, the combination of Nakagawa and Tanner renders obvious claim 3.

**E. Dependent Claim 11**

- 1. [11.1] “The product according to claim 3, wherein the first moisture protectant layer comprises from 5 to 20 percent by weight of calcium carbonate as the filler.”**

As explained above, the combination of Nakagawa and Tanner renders obvious the subject matter of claim 3. *Supra* Section IX.D. Claim 11 only differs from claim 3 in that the filler must be calcium carbonate, not either calcium carbonate or starch. *Compare* Claim 3 *with* Claim 11. As explained above, a

POSITA would have known that calcium carbonate is a non-degradable additive that is commonly used as a filler in biodegradable plastics. Section VIII.C.

Accordingly, the combination of Nakagawa and Tanner renders obvious claim 11.

#### **X. NO SECONDARY CONSIDERATIONS**

Petitioner is unaware of evidence of secondary considerations of non-obviousness having nexus to the Challenged Claims but reserves the right to address any evidence Patent Owner presents.

#### **XI. INSTITUTION IS APPROPRIATE**

It is plain from the detailed discussion of the newly cited art—Cleveland, Nakagawa, and Tanner—that there is a reasonable likelihood that Petitioner will prevail with respect to at least one Challenged Claim. Therefore, institution is appropriate under 35 U.S.C. §314. Further, Petitioner has no knowledge of a parallel proceeding involving the '126 Patent that would allow for a discretionary denial of institution under *Fintiv*. See *Apple Inc. v. Fintiv, Inc.*, IPR2020-00019, Paper 11 at 6 (PTAB Mar. 20, 2020). Petitioner reserves the right to address the *Fintiv* factors should Patent Owner file a related lawsuit.

Neither is discretionary denial under 35 U.S.C. §325 appropriate. Petitioner is unaware of any authority holding *Advanced Bionics*<sup>13</sup> to be satisfied where (like here) the prosecution history lacks discussion of any reference relied upon in this petition. In such situations, the Board routinely does not decline institution on §325 grounds. Moreover, the challenges in this petition are noncumulative because the prior art presented describes the claim limitations that were added to gain allowance and the prior art was not considered by the Examiner. *See* Sections IV-IX.

## **XII. CONCLUSION**

Petitioner respectfully requests that the Board institute trial and cancel the Challenged Claims as unpatentable.

Respectfully submitted,

LEE & HAYES, P.C.

*/James D. Stein/*

James D. Stein  
Registration No. 63,782  
Lead Counsel for Petitioner

Date: April 21, 2025

---

<sup>13</sup> *Advanced Bionics, LLC v. MED-EL Elektromedizinische Geräte GmbH*, IPR2019-01469, Paper 6, 7-10 (PTAB Feb. 13, 2020) (precedential).

**CERTIFICATE OF WORD COUNT (37 C.F.R. §42.24(D))**

This Petition for *Inter Partes* Review complies with the type-volume limitation of 14,000 words, comprising 13,956 words, excluding the parts exempted by 37 C.F.R. §42.24(a)(1).

This Petition for *Inter Partes* Review complies with the general format requirements of 37 C.F.R. §42.6(a) and has been prepared using Microsoft® Word in 14-point Times New Roman font.

Respectfully submitted,

LEE & HAYES, P.C.

*/James D. Stein/*

James D. Stein  
Registration No. 63,782  
Lead Counsel for Petitioner

Date: April 21, 2025

**CERTIFICATE OF SERVICE (37 C.F.R. §§42.6(E)), 42.105(A))**

I certify that the above-captioned PETITION FOR *INTER PARTES* REVIEW FOR U.S. PATENT NO. 8,637,126, PETITIONER'S POWER OF ATTORNEY, and associated Exhibits 1001-1025 were served in their entireties upon the Patent Owner on April 21, 2025, via FedEx® Express at the following addresses:

INTERNATIONAL PAPER COMPANY  
6400 Poplar Avenue, Tower IV - 9th Floor  
Legal Department: Intellectual Property  
Memphis, TN 38197

*Patent Owner's Correspondence Address of Record for*  
U.S. Patent No. 8,637,126

Respectfully submitted,

*/James D. Stein/*

James D. Stein  
Registration No. 63,782  
Lead Counsel for Petitioner

Date: April 21, 2025