



US 20080121962A1

(19) **United States**

(12) **Patent Application Publication**  
**Forbes et al.**

(10) **Pub. No.: US 2008/0121962 A1**

(43) **Pub. Date: May 29, 2008**

(54) **TANTALUM ALUMINUM OXYNITRIDE  
HIGH-K DIELECTRIC AND METAL GATES**

**Publication Classification**

(75) Inventors: **Leonard Forbes**, Corvallis, OR  
(US); **Kie Y. Ahn**, Chappaqua, NY  
(US); **Arup Bhattacharyya**, Essex  
Junction, VT (US)

(51) **Int. Cl.**  
**H01L 27/108** (2006.01)  
**H01L 21/4763** (2006.01)

(52) **U.S. Cl.** ..... **257/310**; 438/591; 257/E21.495;  
257/E27.084

Correspondence Address:  
**SCHWEGMAN, LUNDBERG & WOESSNER,  
P.A.  
P.O. BOX 2938  
MINNEAPOLIS, MN 55402**

(57) **ABSTRACT**

Electronic apparatus and methods of forming the electronic apparatus may include a tantalum aluminum oxynitride film for use in a variety of electronic systems and devices. The tantalum aluminum oxynitride film may be structured as one or more monolayers. The tantalum aluminum oxynitride film may be formed using atomic layer deposition. Metal electrodes may be disposed on a dielectric containing a tantalum aluminum oxynitride film.

(73) Assignee: **Micron Technology, Inc.**

(21) Appl. No.: **11/514,655**

(22) Filed: **Aug. 31, 2006**

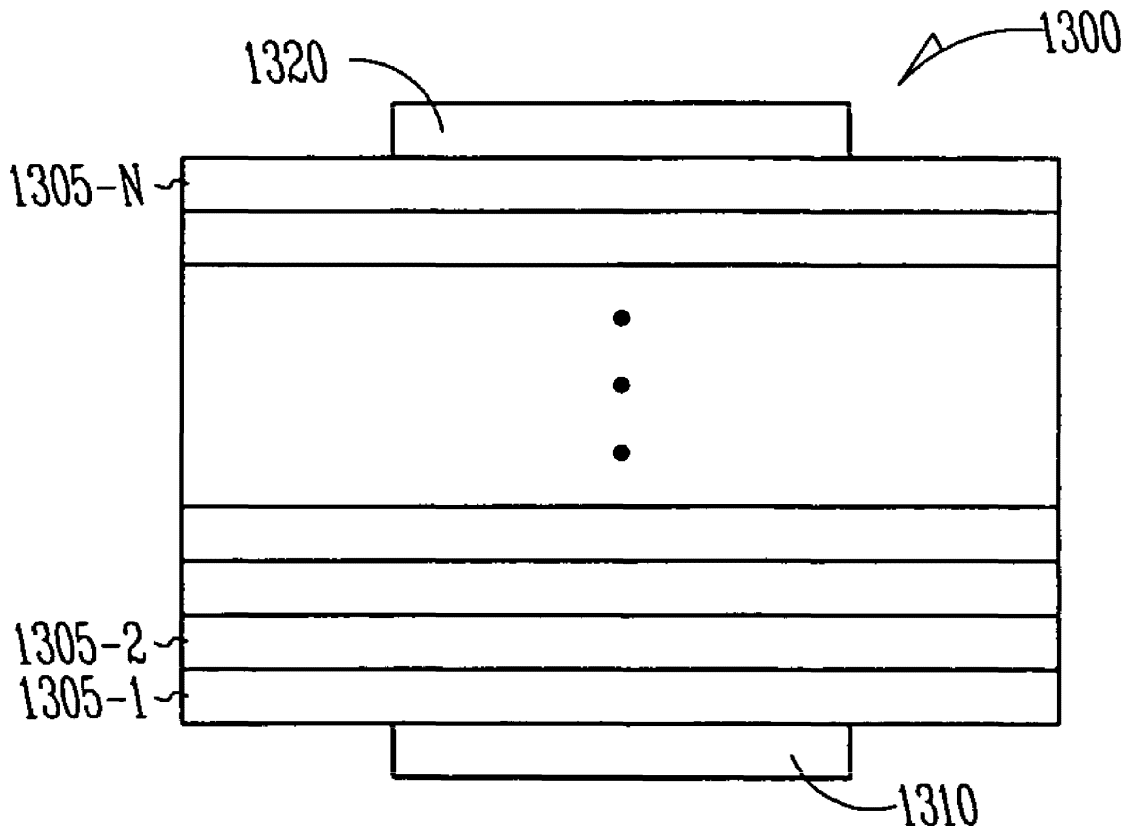

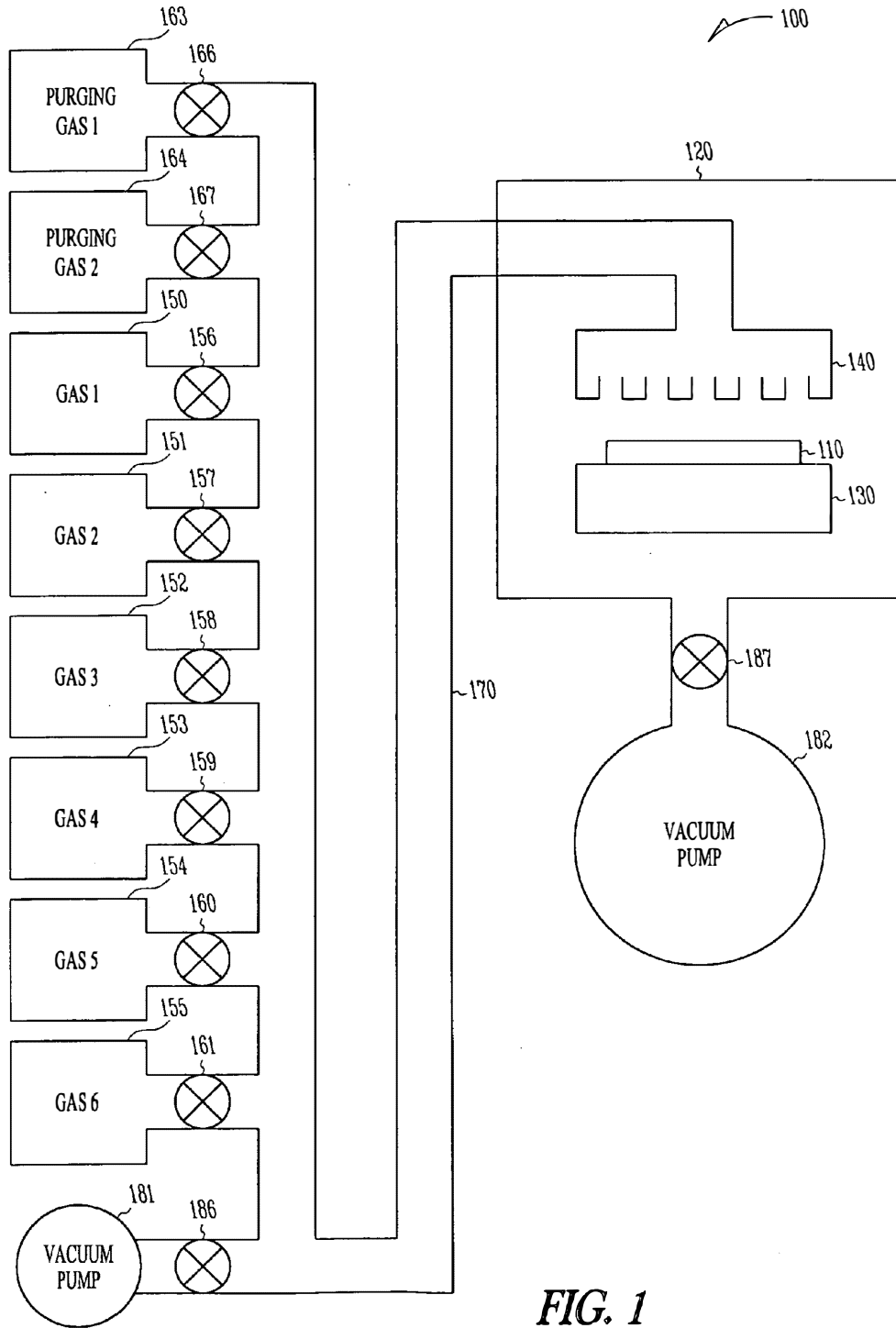
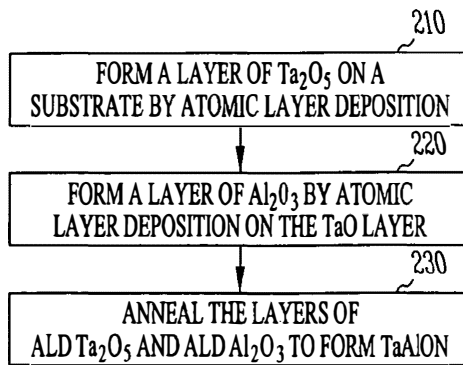
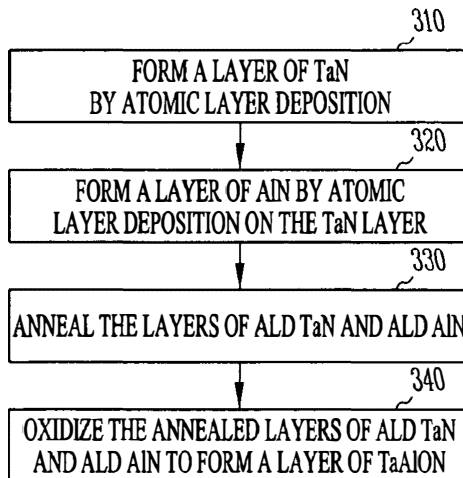

FIG. 1



**FIG. 2**



**FIG. 3**

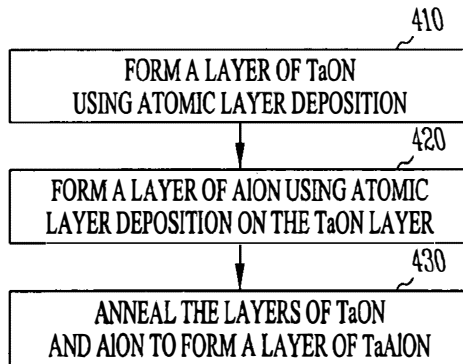

**FIG. 4**

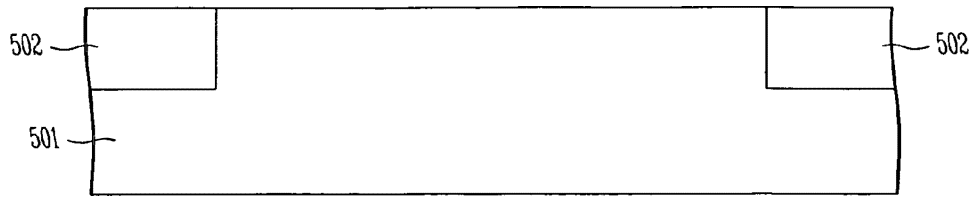

**FIG. 5A**

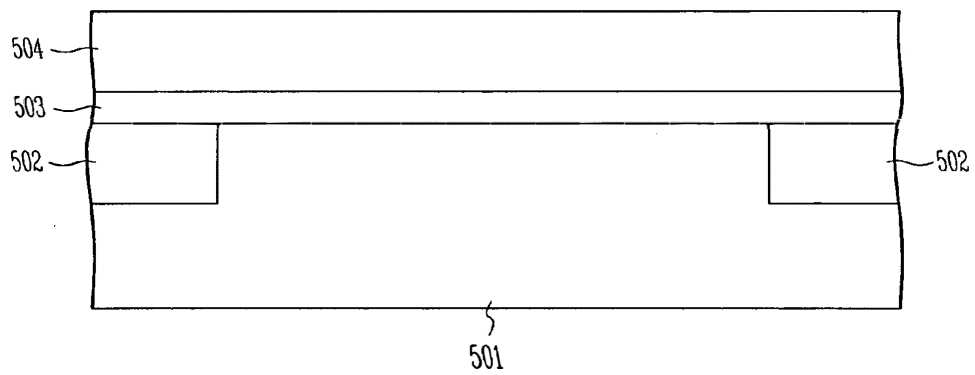

**FIG. 5B**

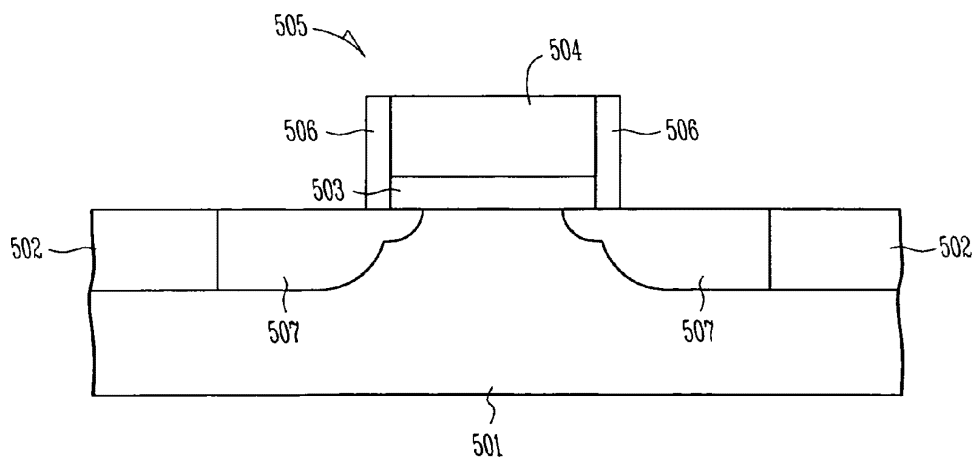

**FIG. 5C**

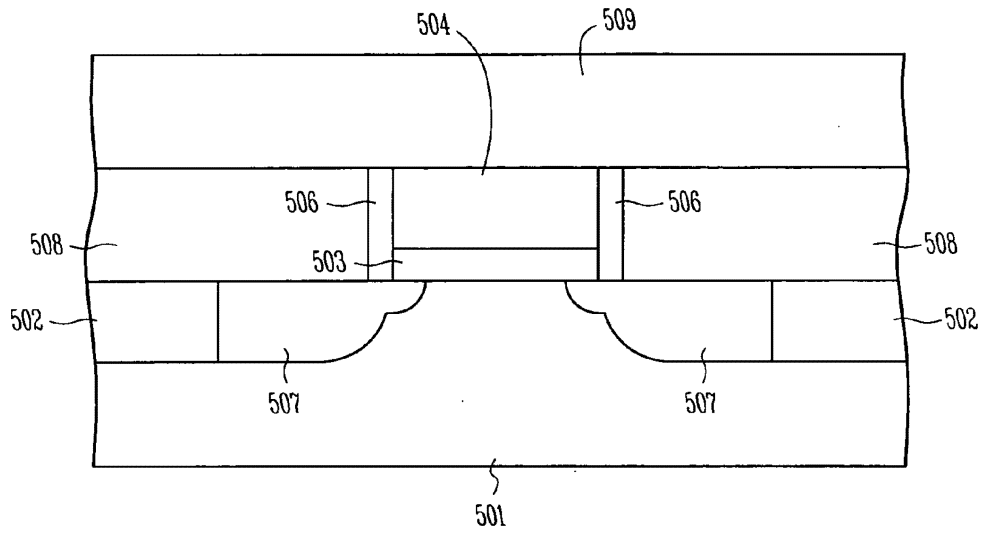

**FIG. 5D**

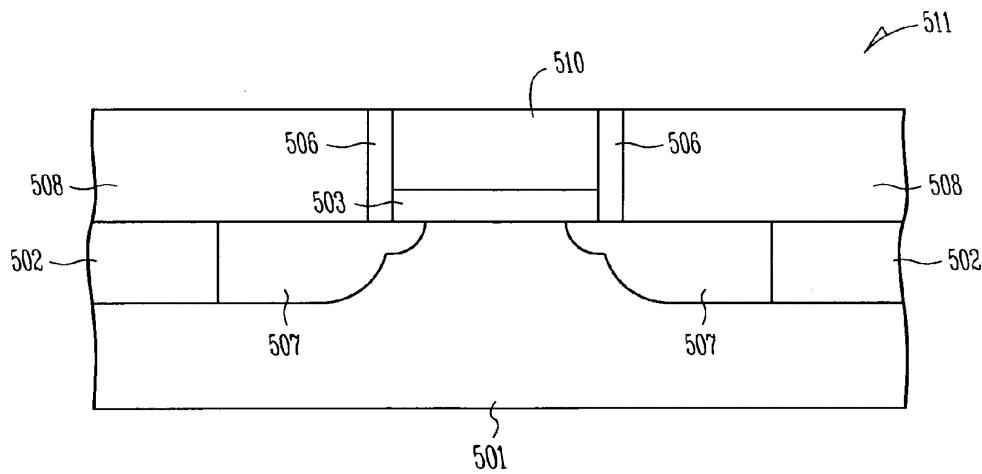

**FIG. 5E**

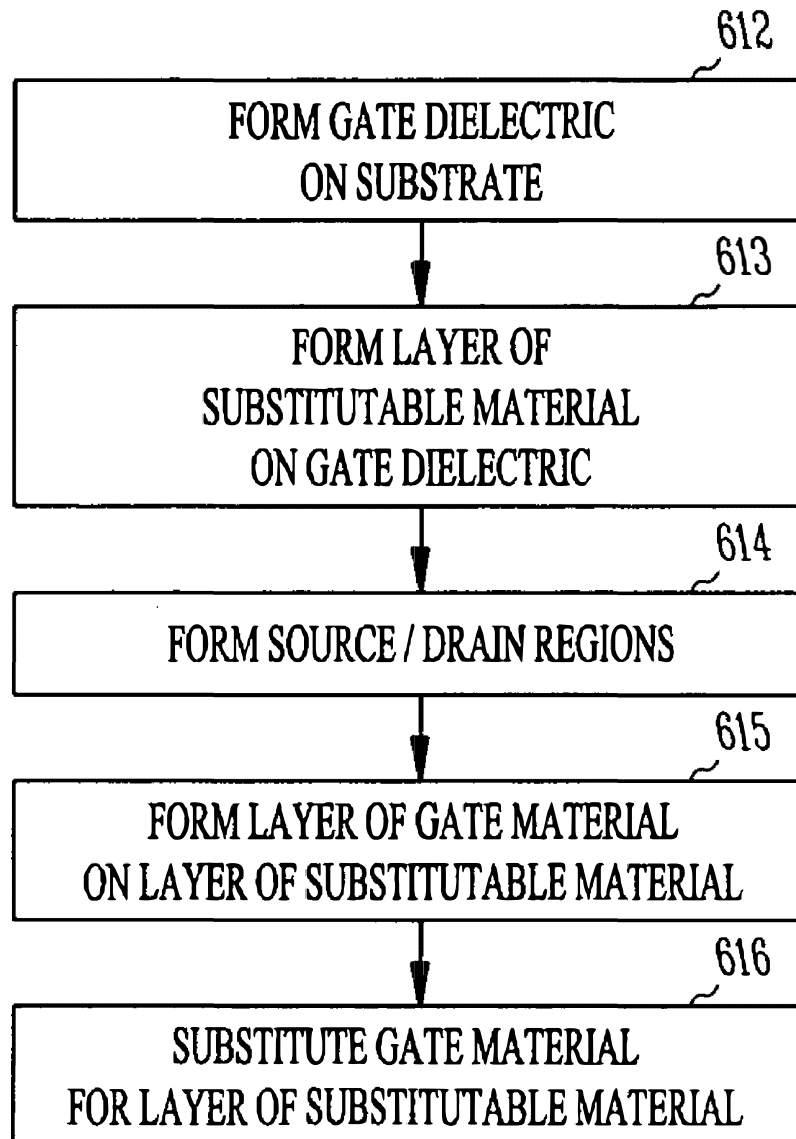

**FIG. 6**

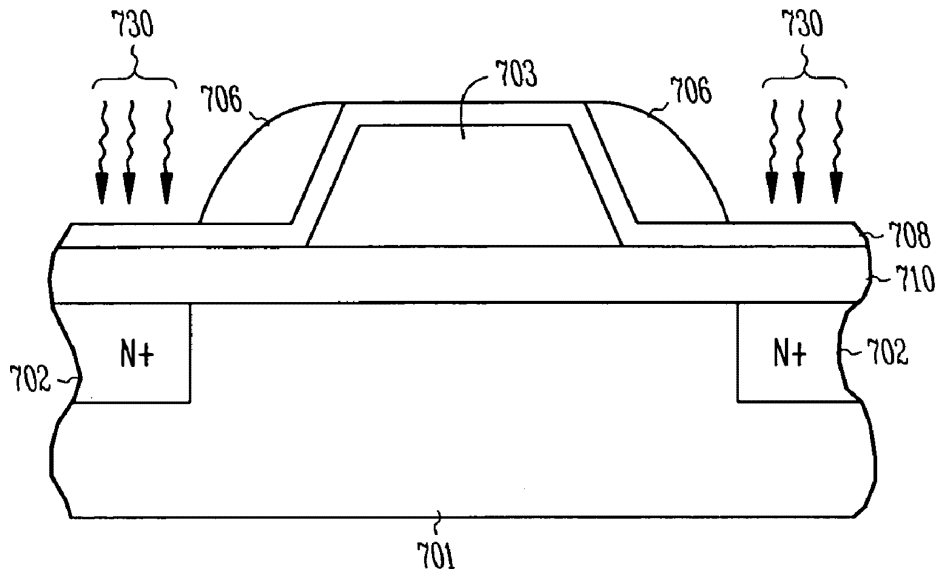

FIG. 7A

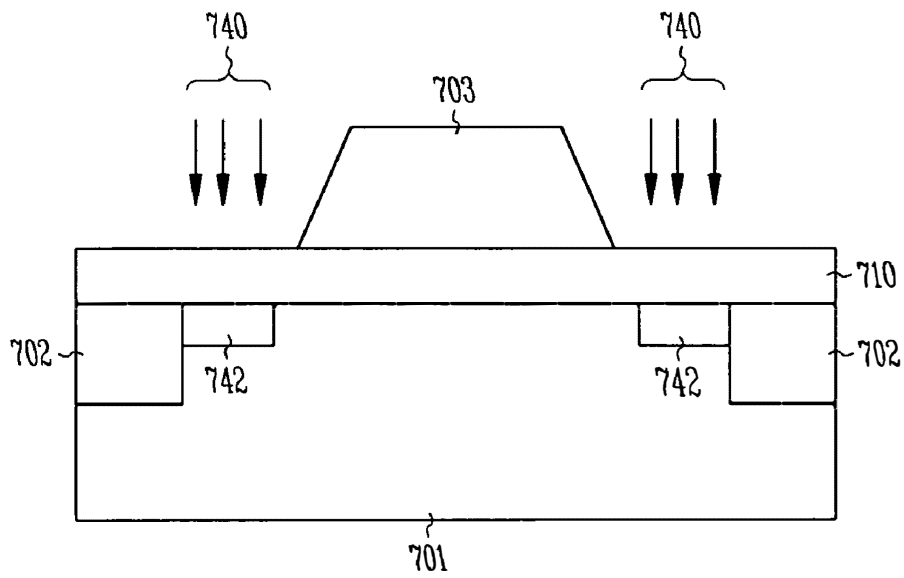
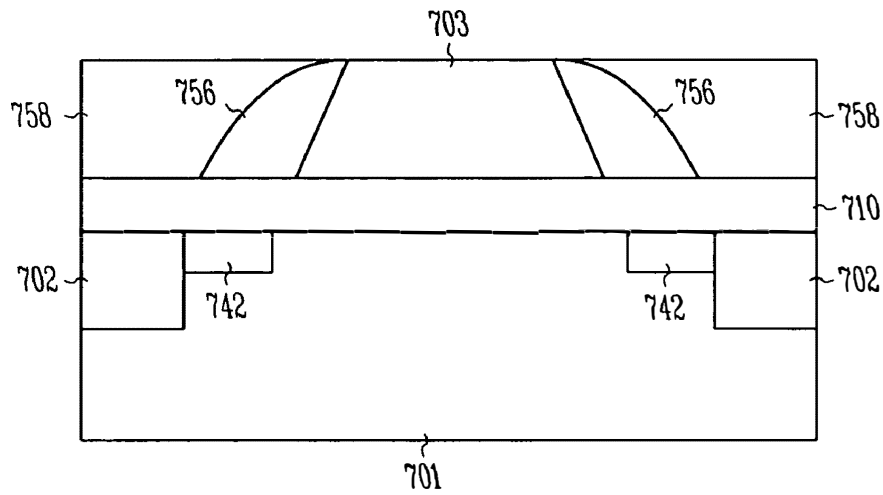
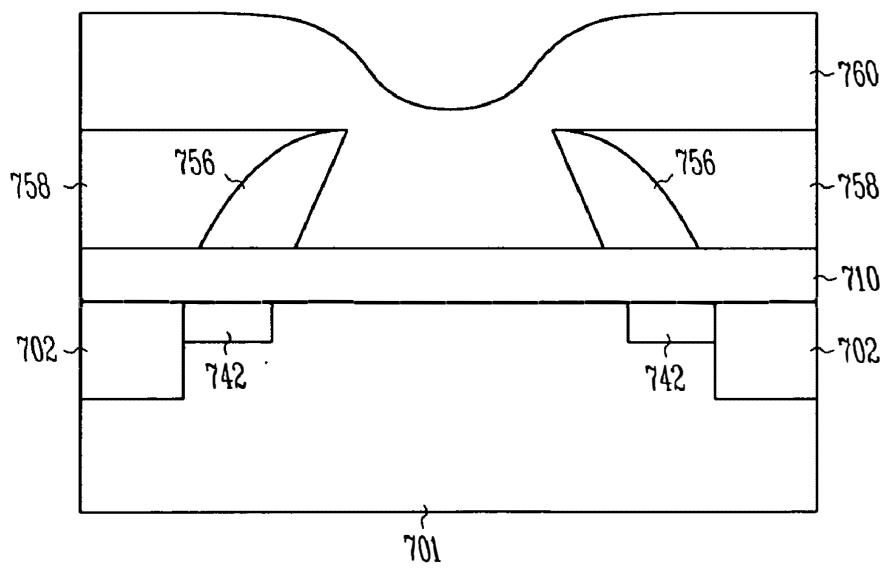

FIG. 7B



**FIG. 7C**



**FIG. 7D**

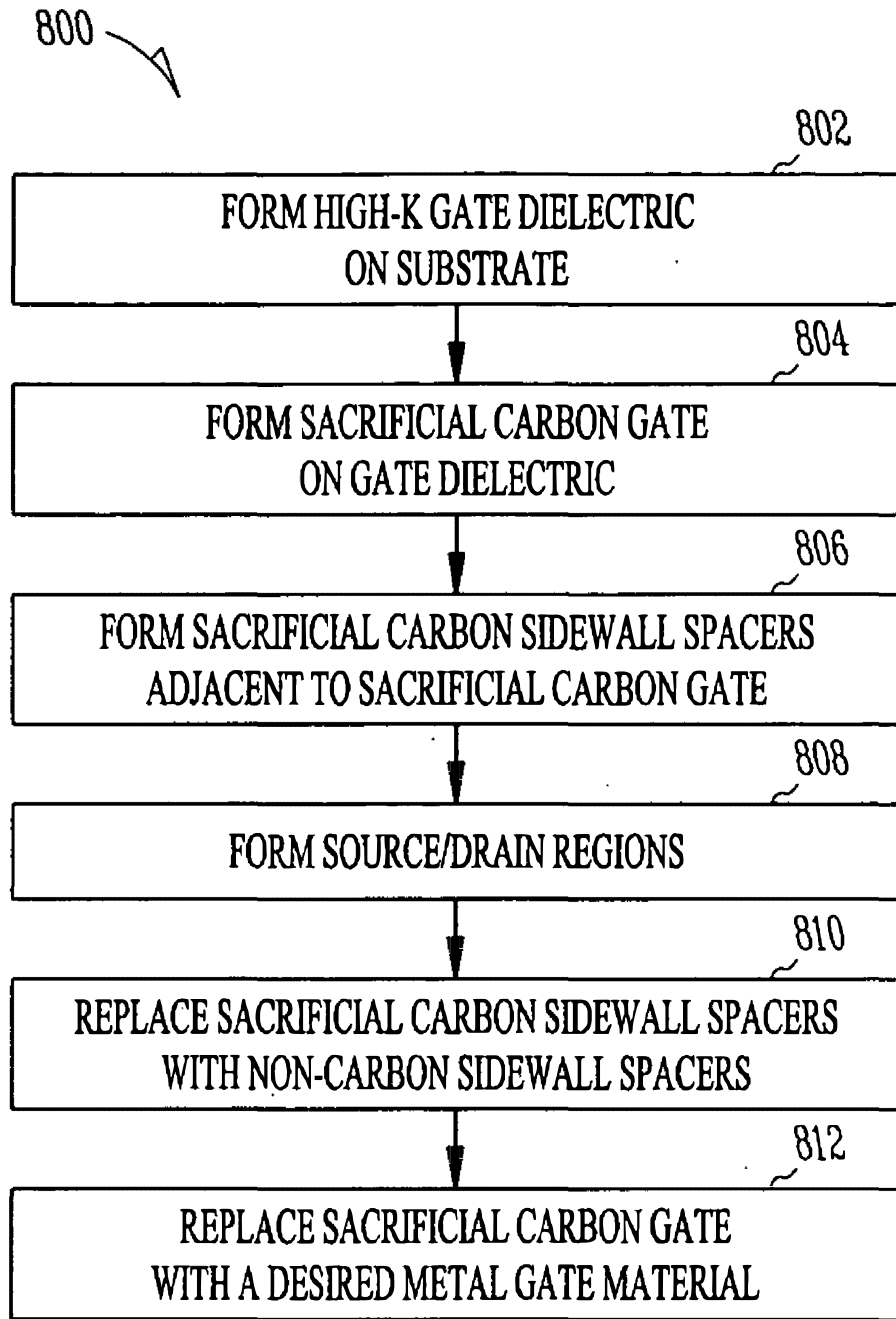

**FIG. 8**

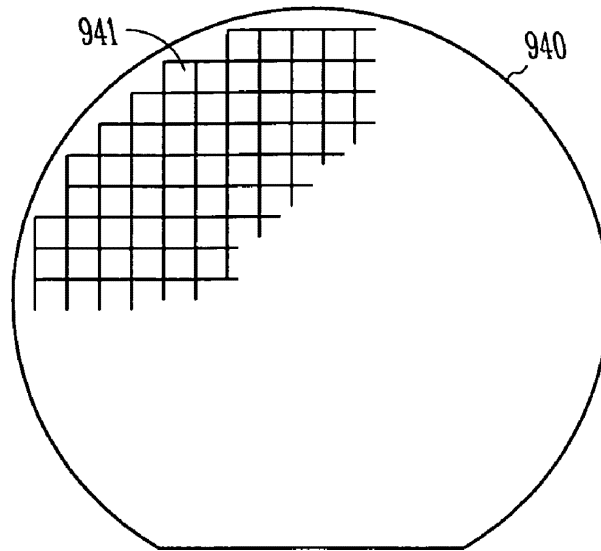

**FIG. 9**

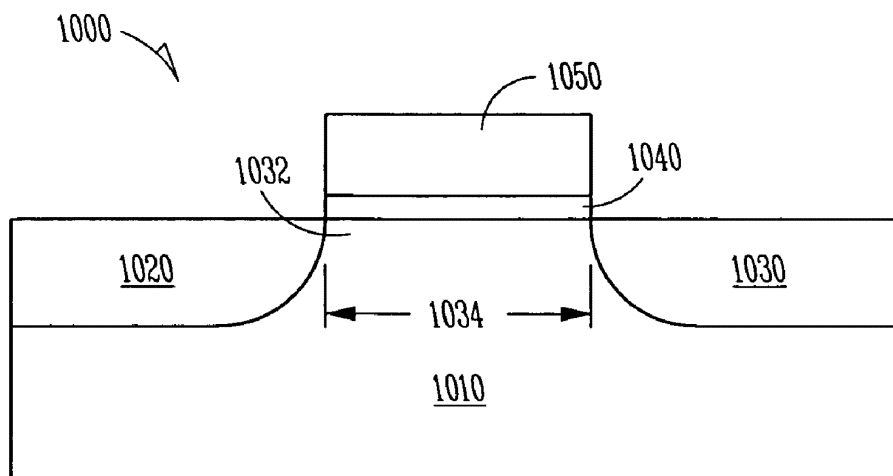

**FIG. 10**

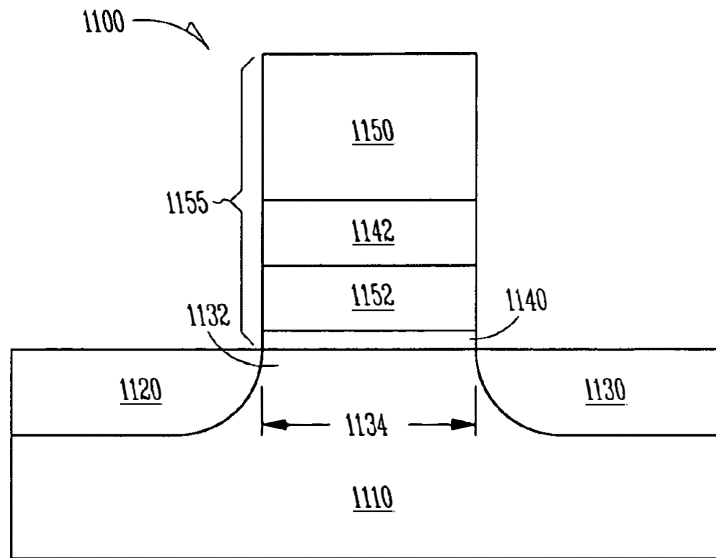

FIG. 11

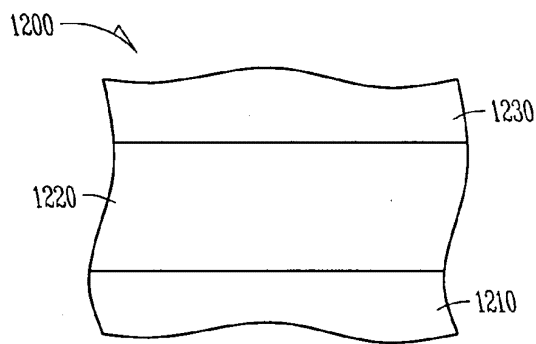

FIG. 12

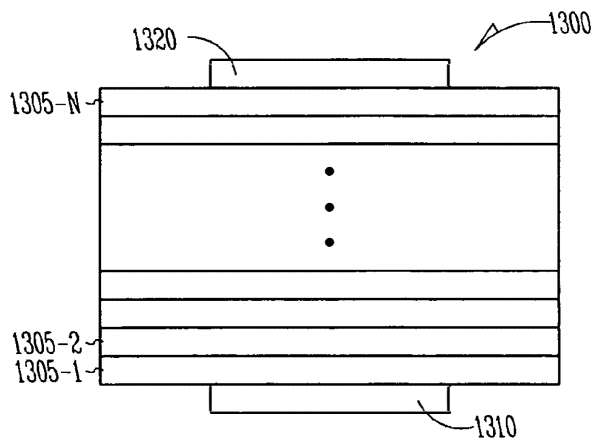
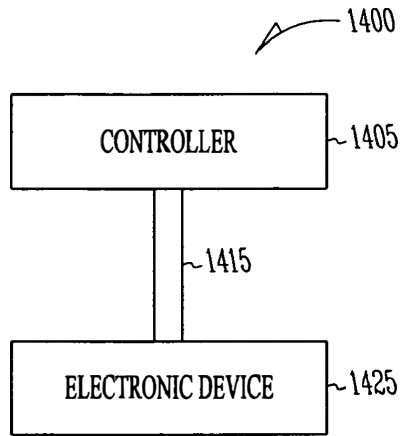
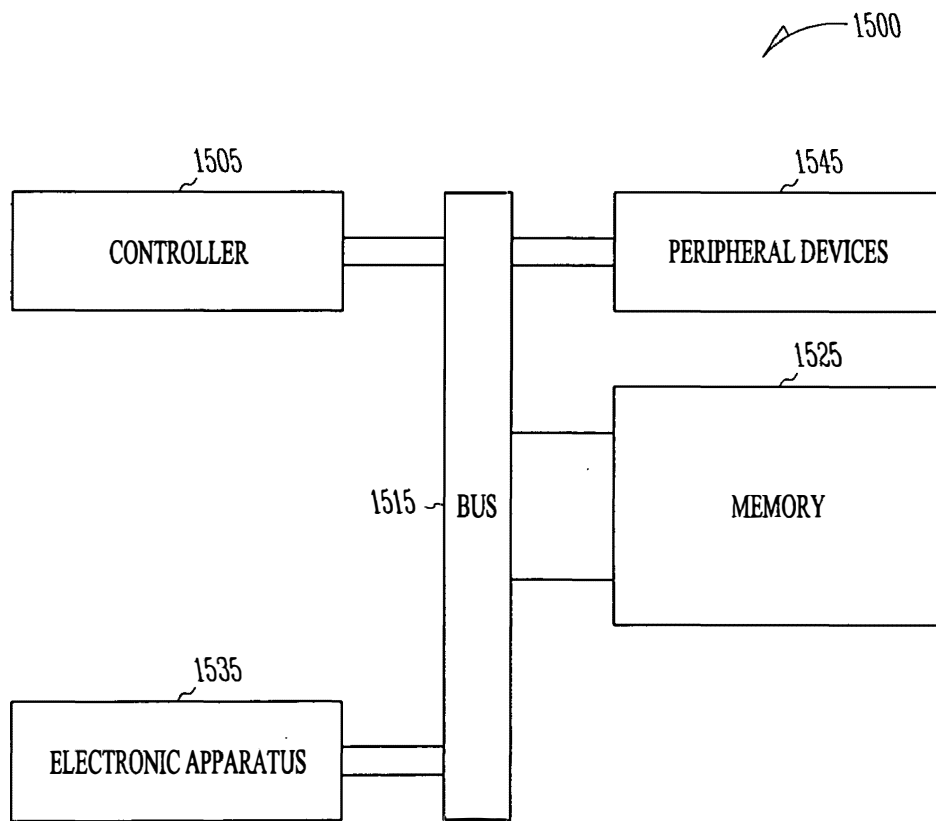

FIG. 13



**FIG. 14**



**FIG. 15**

## TANTALUM ALUMINUM OXYNITRIDE HIGH-K DIELECTRIC AND METAL GATES

### RELATED APPLICATIONS

**[0001]** This application is related to the co-pending and commonly assigned applications U.S. application Ser. No. 10/229,903, entitled "ATOMIC LAYER DEPOSITED HfSiON DIELECTRIC FILMS," filed on 28 Aug. 2002, U.S. application Ser. No. 11/216,474, entitled "LANTHANUM ALUMINUM OXYNITRIDE DIELECTRIC FILMS," filed on 31 Aug. 2005, U.S. application Ser. No. 11/355,490, entitled "CONDUCTIVE LAYERS FOR HAFNIUM SILICON OXYNITRIDE FILMS," filed on 16 Feb. 2006, U.S. application Ser. No. 11/010,529, entitled "ATOMIC LAYER DEPOSITED LANTHANUM HAFNIUM OXIDE DIELECTRICS," filed on 13 Dec. 2004, and U.S. application Ser. No. 10/352,507, entitled "ATOMIC LAYER DEPOSITION OF METAL OXYNITRIDE LAYERS AS GATE DIELECTRICS AND SEMICONDUCTOR DEVICE STRUCTURES UTILIZING METAL OXYNITRIDE LAYER," filed on 27 Jan. 2003, which applications are incorporated herein by reference.

**[0002]** This application is also related to U.S. patent applications filed herewith on the same date. These patent applications are U.S. application Ser. No. \_\_\_\_\_, entitled "ATOMIC LAYER DEPOSITED SILICON LANTHANIDE OXYNITRIDE FILMS" (Attorney Docket No. 1303.179US1), U.S. application Ser. No. \_\_\_\_\_, entitled "ATOMIC LAYER DEPOSITED HAFNIUM LANTHANIDE OXYNITRIDE FILMS" (Attorney Docket No. 1303.180US1), U.S. application Ser. No. \_\_\_\_\_, entitled "\_\_\_\_\_" (Attorney Docket No. 1303.181US1), U.S. application Ser. No. \_\_\_\_\_, entitled "ATOMIC LAYER DEPOSITED TANTALUM LANTHANIDE OXYNITRIDE FILMS" (Attorney Docket No. 1303.182US1), U.S. application Ser. No. \_\_\_\_\_, entitled "\_\_\_\_\_" (Attorney Docket No. 1303.184US1), U.S. application Ser. No. \_\_\_\_\_, entitled "ATOMIC LAYER DEPOSITED HAFNIUM TANTALUM OXYNITRIDE FILMS" (Attorney Docket No. 1303.185US1), and U.S. application Ser. No. \_\_\_\_\_, entitled "\_\_\_\_\_" (Attorney Docket No. 1303.187US1), which patent applications are incorporated herein by reference.

### TECHNICAL FIELD

**[0003]** This application relates generally to semiconductor devices and device fabrication and more particularly, devices having a high-K dielectric.

### BACKGROUND

**[0004]** The semiconductor device industry has a market driven need to reduce the size of devices used in products such as processor chips, mobile telephones, and memory devices such as dynamic random access memories (DRAMs). Currently, the semiconductor industry relies on the ability to reduce or scale the dimensions of its basic devices. This device scaling includes scaling a dielectric layer in devices such as, for example, capacitors and silicon-based metal oxide semiconductor field effect transistors (MOSFETs), which have primarily been fabricated using silicon dioxide. A thermally grown amorphous SiO<sub>2</sub> provides an electrically and thermodynamically stable material, where the interface of the SiO<sub>2</sub> layer with underlying silicon provides a high

quality interface as well as good electrical isolation properties. However, increased scaling and other requirements in microelectronic devices have made SiO<sub>2</sub> less useful because of its band gap and dielectric properties.

### BRIEF DESCRIPTION OF THE DRAWINGS

**[0005]** FIG. 1 depicts an embodiment of an atomic layer deposition system for processing a tantalum aluminum oxynitride film.

**[0006]** FIG. 2 shows a flow diagram of features of an embodiment for forming a tantalum aluminum oxynitride film using atomic layer deposition and nitridization.

**[0007]** FIG. 3 shows a flow diagram of features of an embodiment for forming a tantalum aluminum oxynitride film using atomic layer deposition and oxidation.

**[0008]** FIG. 4 shows a flow diagram of features of an embodiment for forming tantalum aluminum oxynitride film using atomic layer deposition and annealing.

**[0009]** FIGS. 5A-5E illustrate an embodiment of a process for forming a metal substituted electrode.

**[0010]** FIG. 6 illustrates a flow diagram of features of an embodiment of a metal substitution technique.

**[0011]** FIGS. 7A-7D illustrate an embodiment of a process for forming a self aligned conductive layer.

**[0012]** FIG. 8 illustrates an embodiment of a method for forming a self aligned metal gate on high-K gate dielectrics containing a tantalum aluminum oxynitride film.

**[0013]** FIG. 9 illustrates a wafer containing integrated circuits having a tantalum aluminum oxynitride film.

**[0014]** FIG. 10 shows an embodiment of a transistor having a dielectric layer including a tantalum aluminum oxynitride film.

**[0015]** FIG. 11 shows an embodiment of a floating gate transistor having a dielectric layer including a tantalum aluminum oxynitride film.

**[0016]** FIG. 12 shows an embodiment of a capacitor having a dielectric layer including a tantalum aluminum oxynitride film.

**[0017]** FIG. 13 depicts an embodiment of a dielectric layer having multiple layers including a tantalum aluminum oxynitride layer.

**[0018]** FIG. 14 is a simplified diagram for an embodiment of a controller coupled to an electronic device having a dielectric layer including a tantalum aluminum oxynitride film.

**[0019]** FIG. 15 illustrates a diagram for an embodiment of an electronic system including devices with a dielectric film including a tantalum aluminum oxynitride film.

### DETAILED DESCRIPTION

**[0020]** The following disclosure refers to the accompanying drawings that show, by way of illustration, specific details and embodiments. These embodiments are described in sufficient detail to enable those skilled in the art to practice the present invention. Other embodiments may be utilized and structural, logical, and electrical changes may be made without departing from the scope of the invention. The various embodiments are not necessarily mutually exclusive, as some embodiments can be combined with one or more other embodiments to form new embodiments.

**[0021]** In the following description, the terms wafer and substrate may be used interchangeably to refer generally to any structure on which integrated circuits are formed and also to such structures during various stages of integrated circuit

fabrication. The term substrate is understood to include a semiconductor wafer. The term substrate is also used to refer to semiconductor structures during processing and may include other layers that have been fabricated thereupon. Both wafer and substrate include doped and undoped semiconductors, epitaxial semiconductor layers supported by a base semiconductor or insulator, as well as other semiconductor structures well known to one skilled in the art. The term conductor is understood to generally include n-type and p-type semiconductors and the term insulator or dielectric is defined to include any material that is less electrically conductive than the materials referred to as conductors. The term transistor is understood generally to include, an insulated gate field effect transistor such as a metal oxide field effect transistor (MOSFET) and includes complementary metal oxide field effect transistor (CMOS), p-channel (PMOS) and n-channel (NMOS) field effect transistors. The term capacitor is understood to generally include capacitive structures such as used to store electric charge or to provide an electric field. The term composite is understood generally to include a mixture of two or more elements. The following detailed description is, therefore, not to be taken in a limiting sense.

**[0022]** To scale a dielectric region to minimize feature sizes to provide high density electronic devices, the dielectric region should have a reduced equivalent oxide thickness ( $t_{eq}$ ). The equivalent oxide thickness quantifies the electrical properties, such as capacitance, of a dielectric in terms of a representative physical thickness.  $t_{eq}$  is defined as the thickness of a theoretical SiO<sub>2</sub> layer that would be required to have the same capacitance density as a given dielectric, ignoring leakage current and reliability considerations.

**[0023]** A SiO<sub>2</sub> layer of thickness,  $t$ , deposited on a silicon surface will have a  $t_{eq}$  larger than its thickness,  $t$ . This  $t_{eq}$  results from the capacitance in the surface on which the SiO<sub>2</sub> is deposited due to the formation of a depletion/inversion region. This depletion/inversion region can result in  $t_{eq}$  being from 3 to 6 Angstroms (Å) larger than the SiO<sub>2</sub> thickness,  $t$ . Thus, with the semiconductor industry driving to someday scale a gate dielectric equivalent oxide thickness to less than 10 Å, the physical thickness requirement for a SiO<sub>2</sub> layer used for a gate dielectric may need to be approximately 4 to 7 Å. Additional requirements on a SiO<sub>2</sub> layer would depend on the electrode used in conjunction with the SiO<sub>2</sub> dielectric. Using a conventional polysilicon electrode may result in an additional increase in  $t_{eq}$  for the SiO<sub>2</sub> layer. Thus, designs for future devices may be directed towards a physical SiO<sub>2</sub> dielectric layer of about 5 Å or less. Such a reduced thickness requirement for a SiO<sub>2</sub> oxide layer creates additional problems.

**[0024]** SiO<sub>2</sub> is used as a dielectric layer in devices, in part, due to its electrical isolation properties in a SiO<sub>2</sub>-Si based structure. This electrical isolation is due to the relatively large band gap of SiO<sub>2</sub> (8.9 eV), making it a good insulator from electrical conduction. Significant reductions in its band gap may eliminate it as a material for a dielectric region in an electronic device. As the thickness of a SiO<sub>2</sub> layer decreases, the number of atomic layers or monolayers of the material decreases. At a certain thickness, the number of monolayers will be sufficiently small that the SiO<sub>2</sub> layer will not have a complete arrangement of atoms as in a larger or bulk layer. As a result of incomplete formation relative to a bulk structure, a thin SiO<sub>2</sub> layer of only one or two monolayers may not form a full band gap. The lack of a full band gap in a SiO<sub>2</sub> dielectric may cause an effective short between an underlying electrode

and an overlying electrode. This undesirable property sets a limit on the physical thickness to which a SiO<sub>2</sub> layer can be scaled. The minimum thickness due to this monolayer effect is thought to be about 7-8 Å. Therefore, for future devices to have a  $t_{eq}$  less than about 10 Å, other dielectrics than SiO<sub>2</sub> may be considered for use as a dielectric region in such future devices.

**[0025]** In many cases, for a typical dielectric layer, the capacitance is determined as for a parallel plate capacitance:  $C = \kappa \epsilon_0 A / t$ , where  $\kappa$  is the dielectric constant,  $\epsilon_0$  is the permittivity of free space,  $A$  is the area of the capacitor, and  $t$  is the thickness of the dielectric. The thickness,  $t$ , of a material is related to its  $t_{eq}$  for a given capacitance, with SiO<sub>2</sub> having a dielectric constant  $\kappa_{ox} = 3.9$ , as

$$t = (\kappa / \kappa_{ox}) t_{eq} = (\kappa / 3.9) t_{eq}$$

Thus, materials with a dielectric constant greater than that of SiO<sub>2</sub>, 3.9, will have a physical thickness that can be considerably larger than a desired  $t_{eq}$ , while providing the desired equivalent oxide thickness. For example, an alternative dielectric material with a dielectric constant of 10 could have a thickness of about 25.6 Å to provide a  $t_{eq}$  of 10 Å, not including any depletion/inversion layer effects. Thus, a reduced equivalent oxide thickness for transistors can be realized by using dielectric materials with higher dielectric constants than SiO<sub>2</sub>.

**[0026]** The reduced equivalent oxide thickness required for lower device operating voltages and smaller device dimensions may be realized by a significant number of materials, but additional fabricating requirements make determining a suitable replacement for SiO<sub>2</sub> difficult. For example, silicon-based devices may employ a dielectric material employed be grown on a silicon substrate or a silicon layer, which places significant constraints on the substitute dielectric material. During the formation of the dielectric on the silicon layer, there exists the possibility that a small layer of SiO<sub>2</sub> could be formed in addition to the desired dielectric. The result would effectively be a dielectric layer consisting of two sublayers in parallel with each other and the silicon layer on which the dielectric is formed. In such a case, the resulting capacitance would be that of two dielectrics in series. As a result, the  $t_{eq}$  of the dielectric layer would be the sum of the SiO<sub>2</sub> thickness and a multiplicative factor of the thickness,  $t$ , of the dielectric being formed, written as

$$t_{eq} = t_{SiO_2} + (\kappa_{ox} / \kappa) t$$

Thus, if a SiO<sub>2</sub> layer is formed in the process, the  $t_{eq}$  is again limited by a SiO<sub>2</sub> layer. In the event that a barrier layer is formed between the silicon layer and the desired dielectric and the barrier layer prevents the formation of a SiO<sub>2</sub> layer, the  $t_{eq}$  would be limited by the layer with the lowest dielectric constant. However, whether a single dielectric layer with a high dielectric constant or a barrier layer with a dielectric constant greater than SiO<sub>2</sub> is employed, the layer interfacing with the silicon layer should provide a high quality interface.

**[0027]** One of the advantages of using SiO<sub>2</sub> as a dielectric layer in a device has been that the formation of the SiO<sub>2</sub> layer results in an amorphous dielectric. Having an amorphous structure for a dielectric provides for reducing problems of leakage current associated with grain boundaries in polycrystalline dielectrics that provide high leakage paths. Additionally, grain size and orientation changes throughout a polycrystalline dielectric can cause variations in the film's dielectric constant, along with uniformity and surface topography problems. Materials having a high dielectric constant

relative to SiO<sub>2</sub> may also have a crystalline form, at least in a bulk configuration. Good candidates for replacing SiO<sub>2</sub> as a dielectric in a device are those that can be fabricated as a thin layer with an amorphous form and that have high dielectric constants.

**[0028]** Capacitor applications have used high- $\kappa$  dielectric materials, which are insulating materials having a dielectric constant greater than silicon dioxide. Such high- $\kappa$  dielectric materials include silicon oxynitride (SiON,  $\kappa \sim 6$ ), alumina (Al<sub>2</sub>O<sub>3</sub>,  $\kappa \sim 9$ ), and oxide/nitride composites (SiO<sub>2</sub>/Si<sub>3</sub>N<sub>4</sub>,  $\kappa \sim 6$ ). Other possible candidates include metal oxides ( $\kappa \sim 8$ -80), nitrides ( $\kappa \sim 7$ -30), oxynitrides ( $\kappa \sim 6$ -25), silicates ( $\kappa \sim 6$ -20), carbides ( $\kappa \sim 6$ -15), and complex titanates ( $\kappa \sim >100$ ). Factors for selecting appropriate materials include physical, chemical and thermal stability as well as etch-ability and stoichiometric reproducibility. In field effect transistor (FET) applications, there are other factors to consider while addressing device scalability. The selected dielectric should provide stable amorphous and adherent films in the thickness range of 1 nm to 100 nm at temperatures ranging from room temperature to 1000° C. A relatively defect-free composition that is uniform and reproducible with a fixed charge density and trap density of less than 10<sup>11</sup> cm<sup>-2</sup> in films of such composition is a factor. Yet another factor includes dielectric materials that provide a stable non-reactive interface with a silicon substrate such that the interface has an interface state density much less than 10<sup>11</sup> cm<sup>-2</sup>. Such interface state densities may occur when silicon bonds at the interface are saturated with high strength covalent bonds with molecular elements of the dielectric material. Another factor deals with current transport through the dielectric that should be controlled by tunneling, which is independent of temperature, rather than by trap-assisted thermally dependent transport. The conductivity of the dielectric should be equal to or lower than SiO<sub>2</sub> films when voltage is stressed to a field strength of 5×10<sup>6</sup> V/cm. To address the current transport requirements, a dielectric material having a bandgap greater than 5 eV and having an electron and hole barrier height greater than 2 eV at a silicon interface may be considered. An additional factor to consider is using dielectric materials with a destructive breakdown strength greater than 6×10<sup>6</sup> V/cm. Other factors for selecting a dielectric material for use in a variety of electronic devices, such as for the dielectric in FETs, relates to processing characteristics. Such processing characteristics include compatibility with gate material, selective etch-ability, chemical inertness to contaminants, dopant and post processing environments (temperature, pressure, ambients), and intrinsic properties associated with annealing of defects/damages caused by post-processing such as ion-implantation, plasma-radiation, and gate/back-end processing.

**[0029]** In various embodiments, mixed metal oxynitrides are constructed as dielectric films in a variety of electronic devices and systems. Most oxynitrides are thermally stable and can integrate into semiconductor device processing. With nitrogen concentration in an oxynitride film at 30% or higher, such oxynitrides are considered chemically inert. With processing conditions controlled to provide very low partial pressures of hydrogen and ON ions, oxynitride films with a wide range of nitrogen to oxygen ratio can be deposited over a silicon substrate with very low fixed charge and interface states density. On the other hand, charge trapping and transport characteristics are dependent on relative ratio of nitrogen to oxygen content in the constructed film. Films with nitrogen

concentration twice that of oxygen (for example, approximately 40 atomic percent nitrogen, approximately 20 atomic percent oxygen, and approximately 40 atomic percent metal or silicon) have a lower bandgap, higher trap density, and transport characteristics dominated by Frenkel-Poole conduction. Such materials may not be well suited for gate dielectric applications. However, such films also exhibit higher  $\kappa$  values. With increasing oxygen concentration in oxynitride films, the bandgap is raised, current leakage is reduced, and the low frequency K value is also somewhat reduced. In addition with increasing oxygen concentration, the trap density is reduced, the trap energy depth is increased, and the carrier transport ceases to be trap-assisted, exhibits tunneling conduction, with a weakened temperature dependence, if any. In various embodiments, a dielectric layer includes an oxynitride film having approximately 30 atomic % oxygen and approximately 30-35 atomic % nitrogen. With high enough nitrogen content, oxygen-vacancy induced defects in films may be negligible when compared with metal oxides.

**[0030]** Silicon oxynitride (SiON) has been used as a gate dielectric and gate insulator for a non-volatile FET device. Silicon oxynitride at a composition range of Si<sub>2</sub>ON<sub>2</sub> exhibits a dielectric constant of 6.5 and a bandgap of approximately 6.5 eV compared to a stoichiometric nitride of  $\kappa \sim 7.5$  and a bandgap of 5.1 eV. Aluminum oxynitride (AlON) is expected to have a bandgap greater than 5 eV with a  $\kappa$  value similar to SiON. Compared to SiON, metal oxynitrides such as ZrON, HfON, LaON, and TaON and other single metal oxynitrides are expected to have a lower bandgap.

**[0031]** In various embodiments, bimetal (or metal/silicon) oxynitrides based on Si, Al, Hf, La, and Ta are used as dielectric films in a variety of electronic devices and systems. These bimetal oxynitrides may provide a bandgap range from 5 eV to greater than 7 eV. Estimates for bandgaps include a bandgap of Si—Al—ON of greater than 7 eV, a bandgap of Si—Hf—ON of about 6.9 eV, a bandgap of Al—Hf—ON of about 6.8 eV, a bandgap of Si—Ta—ON of about 6 eV, a bandgap of Al—Ta—ON of about 6 eV. Bimetal oxynitrides Hf—Ta—ON, Hf—La—ON, Al—La—ON, Ta—La—ON, and Si—La—ON are estimated to exhibit significantly lower bandgaps. The  $\kappa$  value for Si—Al—ON is estimated at approximately 7 to 8, while the K values for the other oxynitrides of this group are estimated to be in the range from about 15 to 25.

**[0032]** Refractory metals such as tungsten, molybdenum, tantalum, niobium, chromium, vanadium, and rhenium are metals with a melting point significantly higher than non-refractory metals. In various embodiments a refractory metal and a non-refractory metal are used to form a dielectric. In some embodiments a refractory metal and a non-refractory metal are used in combination with oxygen and nitrogen to form a dielectric. Various embodiments include using a refractory metal and a non-refractory metal to form a plurality of layers including oxygen and nitrogen. In some embodiments, stacked dielectric layers are formed using a refractory metal and a non-refractory metal in combination with oxygen and nitrogen. Various embodiments include forming a stacked dielectric structure using refractory metal oxides, refractory metal nitrides, refractory metal oxynitrides, and non-refractory metal oxynitrides. In an embodiment, at least one of the refractory metal, the non-refractory metal, the oxygen and the nitrogen concentration is graded substantially perpendicular to direction of deposition. In an embodiment,

at least one of the refractory metal, the non-refractory metal, the oxygen and the nitrogen concentration is graded substantially parallel to direction of deposition.

**[0033]** In an embodiment, a film of tantalum aluminum oxynitride is used as a dielectric layer for application in a variety of electronic devices, replacing the use of silicon oxide to provide a higher dielectric constant. According to various embodiments, the high-k gate dielectric includes one or more of the following: TaN, AlN, AlON, TaON, TaAlON, TaN/AlN, TaN/AlON, TaON/AlN, TaON/AlON, TaN/Al<sub>2</sub>O<sub>3</sub>, Ta<sub>2</sub>O<sub>5</sub>/AlN, TaON/Al<sub>2</sub>O<sub>3</sub>, Ta<sub>2</sub>O<sub>5</sub>/AlON, and Ta<sub>2</sub>O<sub>5</sub>/Al<sub>2</sub>O<sub>3</sub>. In various embodiments, a dielectric layer may be constructed containing tantalum aluminum oxynitride formed using atomic layer deposition with a metal electrode formed in contact with the dielectric layer. The metal electrode may be formed by atomic layer deposition. The metal electrode may be formed by substituting a desired metal material for a previously disposed substitutable material. The metal electrode may be formed as a self aligned metal electrode on and contacting the dielectric layer. The metal electrode may be formed on the dielectric layer using a previously disposed sacrificial carbon layer on the dielectric layer and sacrificial carbon sidewall spacers adjacent to the sacrificial carbon layer.

**[0034]** The term tantalum aluminum oxynitride is used herein with respect to a composition that essentially consists of tantalum, aluminum, oxygen, and nitrogen in a form that may be stoichiometric, non-stoichiometric, or a combination of stoichiometric and non-stoichiometric. A tantalum aluminum oxynitride film may also be referred to as a tantalum aluminum oxygen nitrogen film. In an embodiment, tantalum aluminum oxynitride may be formed substantially as a stoichiometric tantalum aluminum oxynitride film. In an embodiment, tantalum aluminum oxynitride may be formed substantially as a non-stoichiometric tantalum aluminum oxynitride film. In an embodiment, tantalum aluminum oxynitride may be formed substantially as a combination film of non-stoichiometric tantalum aluminum oxynitride and stoichiometric tantalum aluminum oxynitride. Herein, a tantalum aluminum oxynitride composition may be expressed as TaAlON, Ta<sub>x</sub>Al<sub>2</sub>O<sub>x</sub>N<sub>w</sub>, or other equivalent form. The expression TaAlON or its equivalent forms may be used to include TaAlON in a form that is stoichiometric, non-stoichiometric, or a combination of stoichiometric and non-stoichiometric tantalum aluminum oxynitride. Forms that are stoichiometric, non-stoichiometric, or a combination of stoichiometric and non-stoichiometric, may include expressions such as TaN, AlN, AlON, TaON, TaAlON, TaN/AlN, TaN/AlON, TaON/AlN, TaON/AlON, TaN/Al<sub>2</sub>O<sub>3</sub>, Ta<sub>2</sub>O<sub>5</sub>/AlN, TaON/Al<sub>2</sub>O<sub>3</sub>, Ta<sub>2</sub>O<sub>5</sub>/AlON, and Ta<sub>2</sub>O<sub>5</sub>/Al<sub>2</sub>O<sub>3</sub>. In various embodiments, a tantalum aluminum oxynitride film may be doped with elements or compounds other than tantalum, aluminum, oxygen, and nitrogen.

#### Atomic Layer Deposition

**[0035]** In an embodiment, a tantalum aluminum oxynitride dielectric film is formed using atomic layer deposition (ALD). Forming such structures using atomic layer position may allow control of transitions between material layers. As a result of such control, atomic layer deposited tantalum aluminum oxynitride dielectric films can have an engineered transition with a substrate surface.

**[0036]** ALD, also known as atomic layer epitaxy (ALE), is a modification of chemical vapor deposition (CVD) and is

also called "alternatively pulsed-CVD." In ALD, gaseous precursors are introduced one at a time to the substrate surface mounted within a reaction chamber (or reactor). This introduction of the gaseous precursors takes the form of pulses of each gaseous precursor. In a pulse of a precursor gas, the precursor gas is made to flow into a specific area or region for a short period of time. Between the pulses, the reaction chamber may be purged with a gas, where the purging gas may be an inert gas. Between the pulses, the reaction chamber may be evacuated. Between the pulses, the reaction chamber may be purged with a gas and evacuated.

**[0037]** In a chemisorption-saturated ALD (CS-ALD) process, during the first pulsing phase, reaction with the substrate occurs with the precursor saturatively chemisorbed at the substrate surface. Subsequent pulsing with a purging gas removes precursor excess from the reaction chamber.

**[0038]** The second pulsing phase introduces another precursor on the substrate where the growth reaction of the desired film takes place. Subsequent to the film growth reaction, reaction byproducts and precursor excess are purged from the reaction chamber. With favorable precursor chemistry where the precursors absorb and react with each other aggressively on the substrate, one ALD cycle can be performed in less than one second in properly designed flow type reaction chambers. Typically, precursor pulse times range from about 0.5 sec to about 2 to 3 seconds. Pulse times for purging gases may be significantly longer, for example, pulse times of about 5 to about 30 seconds.

**[0039]** In ALD, the saturation of all the reaction and purging phases makes the growth self-limiting. This self-limiting growth results in large area uniformity and conformality, which has important applications for such cases as planar substrates, deep trenches, and in the processing of porous silicon and high surface area silica and alumina powders. Atomic layer deposition provides control of film thickness in a straightforward manner by controlling the number of growth cycles.

**[0040]** The precursors used in an ALD process may be gaseous, liquid or solid. However, liquid or solid precursors should be volatile. The vapor pressure should be high enough for effective mass transportation. Also, solid and some liquid precursors may be heated inside the atomic layer deposition system and introduced through heated tubes to the substrates. The necessary vapor pressure should be reached at a temperature below the substrate temperature to avoid the condensation of the precursors on the substrate. Due to the self-limiting growth mechanisms of ALD, relatively low vapor pressure solid precursors can be used, though evaporation rates may vary somewhat during the process because of changes in their surface area.

**[0041]** There are several other characteristics for precursors used in ALD. The precursors should be thermally stable at the substrate temperature, because their decomposition may destroy the surface control and accordingly the advantages of the ALD method that relies on the reaction of the precursor at the substrate surface. A slight decomposition, if slow compared to the ALD growth, may be tolerated.

**[0042]** The precursors should chemisorb on or react with the surface, though the interaction between the precursor and the surface as well as the mechanism for the adsorption is different for different precursors. The molecules at the substrate surface should react aggressively with the second precursor to form the desired solid film. Additionally, precursors should not react with the film to cause etching, and precursors

should not dissolve in the film. Using highly reactive precursors in ALD contrasts with the selection of precursors for conventional CVD. The by-products in the reaction should be gaseous in order to allow their easy removal from the reaction chamber. Further, the by-products should not react or adsorb on the surface.

**[0043]** In a reaction sequence ALD (RS-ALD) process, the self-limiting process sequence involves sequential surface chemical reactions. RS-ALD relies on chemistry between a reactive surface and a reactive molecular precursor. In an RS-ALD process, molecular precursors are pulsed into the ALD reaction chamber separately. A metal precursor reaction at the substrate may be followed by an inert gas pulse to remove excess precursor and by-products from the reaction chamber prior to pulsing the next precursor of the fabrication sequence.

**[0044]** By RS-ALD, films can be layered in equal metered sequences that may all be substantially identical in chemical kinetics, deposition per cycle, composition, and thickness. RS-ALD sequences generally deposit less than a full layer per cycle. Typically, a deposition or growth rate of about 0.25 to about 2.00 Å per RS-ALD cycle may be realized.

**[0045]** Processing by RS-ALD provides continuity at an interface avoiding poorly defined nucleating regions that are typical for chemical vapor deposition (<20 Å) and physical vapor deposition (<50 Å), conformality over a variety of substrate topologies due to its layer-by-layer deposition technique, use of low temperature and mildly oxidizing processes, lack of dependence on the reaction chamber, growth thickness dependent solely on the number of cycles performed, and ability to engineer multilayer laminate films with a resolution of one to two monolayers. RS-ALD processes allow for deposition control on the order of monolayers and the ability to deposit monolayers of amorphous films.

**[0046]** Herein, a sequence refers to ALD material formation based on an ALD reaction of a precursor with its reactant precursor. For example, forming tantalum oxide from a TaCl<sub>5</sub> precursor and H<sub>2</sub>O, as its reactant precursor, forms an embodiment of a tantalum/oxygen sequence, which can also be referred to as a tantalum sequence. Additional information regarding tantalum oxides formed by ALD can be found in U.S. patent application Ser. No. 11/029,757, entitled "ATOMIC LAYER DEPOSITED HAFNIUM TANTALUM OXIDE DIELECTRICS," which is herein incorporated by reference. An aluminum precursor can include a variety of precursors, such as trimethylaluminum (TMA), triisobutylaluminum (TIBA), dimethylaluminum hydride (DMAH), AlC<sub>3</sub>, and other halogenated precursors and organometallic precursors. Oxidants can include a water-argon mixture formed by bubbling an argon carrier through a water reservoir, H<sub>2</sub>O<sub>2</sub>, O<sub>2</sub>, O<sub>3</sub>, and N<sub>2</sub>O to form an embodiment of an aluminum/oxygen sequence, which is also referred to as an aluminum sequence. Additional information regarding aluminum oxides formed by ALD can be found in U.S. Patent Application Publication 20030207032A1, entitled "METHODS, SYSTEMS, AND APPARATUS FOR ATOMIC-LAYER DEPOSITION OF ALUMINUM OXIDES IN INTEGRATED CIRCUITS," which is herein incorporated by reference.

**[0047]** Herein, a precursor that contains nitrogen and that supplies nitrogen to be incorporated in the ALD composition formed, which may be used in an ALD process with precursors supplying the other elements in the ALD composition, is referred to as a nitrogen reactant precursor. Similarly, an ALD

sequence for a metal oxide may be referenced with respect to the metal and oxygen. An ALD cycle may include pulsing a precursor, pulsing a purging gas for the precursor, pulsing a reactant precursor, and pulsing the reactant precursor's purging gas. An ALD cycle may include pulsing a precursor, evacuating the reactant chamber, pulsing a reactant precursor, and evacuating the reactant chamber. An ALD cycle may include pulsing a precursor, pulsing a purging gas for the precursor and evacuating the reactant chamber, pulsing a reactant precursor, and pulsing the reactant precursor's purging gas and evacuating the reactant chamber.

**[0048]** In forming a layer of a metal species, an ALD sequence may deal with pulsing a reactant precursor to the substrate surface on which a metal-containing species has been absorbed such that the reactant precursor reacts with the metal-containing species resulting in the deposited metal and a gaseous by-product that can be removed during the subsequent purging/evacuating process. Alternatively, in forming a layer of a metal species, an ALD sequence may include reacting a precursor containing the metal species with a substrate surface. A cycle for such a metal forming sequence may include pulsing a purging gas after pulsing the precursor containing the metal species to deposit the metal. Additionally, deposition of a semiconductor material may be realized in a manner similar to forming a layer of a metal, given the appropriate precursors for the semiconductor material.

**[0049]** In an ALD formation of a composition having more than two elements, a cycle may include a number of sequences to provide the elements of the composition. For example, a cycle for an ALD formation of an ABO<sub>x</sub> composition, where "A" is a first element, e.g., a metal, and "B" is a second element, e.g., a metal, may include sequentially [pulsing a first precursor/a purging gas for the first precursor/a first reactant precursor/the first reactant precursor's purging gas] followed by [a second precursor/a purging gas for the second precursor/a second reactant precursor/the second reactant precursor's purging gas], which may be viewed as a cycle having two sequences. In an embodiment, a cycle may include a number of sequences for element A and a different number of sequences for element B. There may be cases in which ALD formation of an ABO<sub>x</sub> composition uses one precursor that contains the elements A and B, such that pulsing the AB containing precursor followed by its reactant precursor onto a substrate may include a reaction that forms ABO<sub>x</sub> on the substrate to provide an AB/oxygen sequence. A cycle of an AB/oxygen sequence may include pulsing a precursor containing A and B, pulsing a purging gas for the precursor, pulsing an oxygen reactant precursor to the A/B precursor, and pulsing a purging gas for the reactant precursor. A cycle may be repeated a number of times to provide a desired thickness of the composition. In an embodiment, a cycle for an ALD formation of the quaternary composition, tantalum aluminum oxygen nitrogen, may include sequentially [pulsing a first precursor/a purging gas for the first precursor/a first reactant precursor/the first reactant precursor's purging gas] followed by [a second precursor/a purging gas for the second precursor/a second reactant precursor/the second reactant precursor's purging gas] followed by [a third precursor/a purging gas for the third precursor/a third reactant precursor/the third reactant precursor's purging gas], which may be viewed as a cycle having three sequences. In an embodiment, a layer substantially of a tantalum aluminum oxynitride composition is formed on a substrate mounted in a reaction chamber using ALD in repetitive aluminum/oxygen

and tantalum/oxygen sequences using precursor gases individually pulsed into the reaction chamber and heating the stacked layer structure in a nitrogen environment, such as dinitrogen, ammonia, or 1,1-dimethyl-hydrazine. In some embodiments the TaAlON dielectric film is a homogenous mixture. In an embodiment, a substantially pure tantalum aluminum oxynitride composition is formed by ALD having approximately 30% nitrogen and 30% oxygen concentrations in the resultant TaAlON dielectric film. In some embodiments, a substantially pure tantalum aluminum oxynitride composition is formed by ALD having approximately 20-40% nitrogen and 20-40 atomic % oxygen concentrations in the resultant TaAlON dielectric film.

[0050] FIG. 1 shows an embodiment of an atomic layer deposition system 100 for processing a dielectric film containing a  $Ta_xAl_yO_zN_w$  layer. The elements depicted used to discuss various embodiments for forming TaAlON such that those skilled in the art may practice the present invention without undue experimentation. A substrate 110 is located inside a reaction chamber 120 of ALD system 100. Also located within reaction chamber 120 may be a heating element 130, which is thermally coupled to substrate 110 to control the substrate temperature. A gas-distribution fixture 140 introduces precursor gases to the substrate 110. Each precursor gas originates from individual gas sources 150-155 whose flow is controlled by flow controllers 156-161, respectively. Gas sources 150-155 provide a precursor gas either by storing the precursor as a gas or by providing a location and apparatus for evaporating a solid or liquid material to form the selected precursor gas. Furthermore, additional gas sources may be included, one or more for each metal precursor employed and one for each reactant precursor associated with each metal precursor, if desired. In various embodiments, the flow controllers are mass-flow controllers. In an embodiment the flow controllers are rotameters. In an embodiment the flow controllers use ultrasound to control flow.

[0051] Also included in the ALD system are purging gas sources 163, 164, each of which is coupled to flow controllers 166, 167, respectively. Furthermore, additional purging gas sources may be constructed in ALD system 100, one purging gas source for each precursor gas. For a process that uses the same purging gas for multiple precursor gases, less purging gas sources are required for ALD system 100. Gas sources 150-155 and purging gas sources 163-164 are coupled by their associated flow controllers to a common gas line or conduit 170, which is coupled to the gas-distribution fixture 140 inside reaction chamber 120. Gas conduit 170 is also coupled to vacuum pump, or exhaust pump, 181 by flow controller 186 to remove excess precursor gases, purging gases, and by-product gases at the end of a purging sequence from gas conduit 170.

[0052] The vacuum pump, or exhaust pump, 182 is coupled by controller 187 to remove excess precursor gases, purging gases, and by-product gases at the end of a purging sequence from reaction chamber 120. For convenience, and to avoid obscuring various elements in the figure control displays, mounting apparatus, temperature sensing devices, substrate maneuvering apparatus, and necessary electrical connections known to those skilled in the art are not shown in FIG. 1. The use, construction and fundamental operation of reaction chambers for deposition of films are understood by those of ordinary skill in the art of semiconductor fabrication. Embodiments of the present invention may be practiced on a variety of such reaction chambers without undue experimen-

tation. Furthermore, one of ordinary skill in the art will comprehend the necessary detection, measurement, and control techniques in the art of semiconductor fabrication upon reading this disclosure.

[0053] In an embodiment, a tantalum aluminum oxynitride layer may be structured as one or more monolayers. A film of tantalum aluminum oxynitride, structured as one or more monolayers, may have a thickness ranges from a monolayer to thousands of angstroms or more. The film may be processed using atomic layer deposition. Embodiments of an atomic layer deposited tantalum aluminum oxynitride layer have a larger dielectric constant than silicon dioxide. Such dielectric layers provide a significantly thinner equivalent oxide thickness compared with a silicon oxide layer having the same physical thickness. Alternatively, such dielectric layers provide a significantly thicker physical thickness than a silicon oxide layer having the same equivalent oxide thickness. This increased physical thickness aids in reducing leakage current.

[0054] Prior to forming the tantalum aluminum oxynitride film using ALD, the surface on which the tantalum aluminum oxynitride film is to be deposited may undergo a preparation stage. The surface may be the surface of a substrate for an integrated circuit. In an embodiment, the substrate used for forming a transistor may include a silicon or silicon containing material. In other embodiments, silicon germanium, germanium, gallium arsenide, silicon-on-sapphire substrates, or other suitable substrates may be used. A preparation process may include cleaning the substrate and forming layers and regions of the substrate, such as drains and sources, prior to forming a gate dielectric in the formation of a metal oxide semiconductor (MOS) transistor. Alternatively, active regions may be formed after forming the dielectric layer, depending on the over-all fabrication process implemented. In an embodiment, the substrate is cleaned to provide an initial substrate depleted of its native oxide. In an embodiment, the initial substrate is cleaned also to provide a hydrogen-terminated surface. In an embodiment, a silicon substrate undergoes a final hydrofluoric (HF) rinse prior to ALD processing to provide the silicon substrate with a hydrogen-terminated surface without a native silicon oxide layer.

[0055] Cleaning immediately preceding atomic layer deposition aids in reducing an occurrence of silicon oxide as an interface between a silicon-based substrate and a tantalum aluminum oxynitride dielectric formed using the atomic layer deposition process. The material composition of an interface layer and its properties are typically dependent on process conditions and the condition of the substrate before forming the dielectric layer. Though the existence of an interface layer may effectively reduce the dielectric constant associated with the dielectric layer and its substrate interface layer, a  $SiO_2$  interface layer or other composition interface layer may improve the interface density, fixed charge density, and channel mobility of a device having this interface layer.

[0056] The sequencing of the formation of the regions of an electronic device, such as a transistor, may follow sequencing that is generally performed in the fabrication of such devices as is well known to those skilled in the art. Included in the processing prior to forming a dielectric may be the masking of substrate regions to be protected during the dielectric formation, as is typically performed in semiconductor fabrication. In an embodiment, an unmasked region includes a body

region of a transistor; however, one skilled in the art will recognize that other semiconductor device structures may utilize this process.

**[0057]** In various embodiments, between each pulsing of a precursor used in an atomic layer deposition process, a purging gas may be pulsed into the ALD reaction chamber. Between each pulsing of a precursor, the ALD reactor chamber may be evacuated using vacuum techniques as is known by those skilled in the art. Between each pulsing of a precursor, a purging gas may be pulsed into the ALD reaction chamber and the ALD reactor chamber may be evacuated.

**[0058]** In an embodiment, an ALD cycle for forming TaAlON includes sequencing component-containing precursors in the order of tantalum, oxygen, aluminum, and nitrogen with appropriate purging between the different component-containing precursors. Full coverage or partial coverage of a monolayer on a substrate surface may be attained for pulsing of a metal-containing precursor. In an embodiment, an ALD cycle for forming TaAlON includes sequencing the component-containing precursors in various permutations. In an embodiment, an ALD cycle to form tantalum aluminum oxynitride includes alternating or cycling a tantalum/nitrogen sequence and an aluminum/nitrogen sequence. In an embodiment, an ALD cycle to form tantalum aluminum oxynitride includes alternating or cycling a tantalum/nitrogen sequence and an aluminum/nitrogen sequence. The tantalum aluminum oxynitride may be tantalum-rich dielectric relative to the amount of aluminum in the dielectric. The pulsing of the individual component-containing precursors may be performed independently in a non-overlapping manner using the individual gas sources **150-155** and flow controllers **156-161** of ALD system **100** of FIG. 1.

**[0059]** Each precursor may be pulsed into the reaction chamber for a predetermined period, where the predetermined period can be set separately for each precursor. Additionally, for various ALD formations, each precursor may be pulsed into the reaction chamber under separate environmental conditions. The substrate may be maintained at a selected temperature and the reaction chamber maintained at a selected pressure independently for pulsing each precursor. Appropriate temperatures and pressures may be maintained, whether the precursor is a single precursor or a mixture of precursors.

**[0060]** A number of precursors containing tantalum may be used to provide the tantalum to a substrate for an integrated circuit. A number of precursors containing tantalum that may be used includes, but is not limited to  $\text{TaCl}_5$ ,  $(\text{Ta}(\text{N}-t\text{-C}_5\text{H}_{11})[\text{N}(\text{CH}_3)_2]_3)$ , and tantalum ethoxide  $\text{Ta}(\text{OC}_2\text{H}_5)_5$ . In an embodiment,  $\text{H}_2$  may be pulsed along with a precursor to reduce carbon contamination in the fabricated film. Aluminum precursors can include a variety of precursors, such as trimethylaluminum (TMA), triisobutylaluminum (TIBA), dimethylaluminum hydride (DMAH),  $\text{AlCl}_3$ , Trimethylamine Alane (TMAA), and other halogenated precursors and organometallic precursors.

**[0061]** In various embodiments, after pulsing the tantalum-containing precursor and purging the reaction chamber of excess precursor and by-products from pulsing the precursor, a reactant precursor may be pulsed into the reaction chamber. The reactant precursor may be an oxygen reactant precursor that may include, but is not limited to, one or more of water, atomic oxygen, molecular oxygen, ozone, hydrogen peroxide, a water-hydrogen peroxide mixture, alcohol, or nitrous oxide. In addition, the pulsing of the precursor may use a

pulsing period that provides uniform coverage of a monolayer on the surface or may use a pulsing period that provides partial coverage of a monolayer on the surface during a sequence.

**[0062]** In addition, the pulsing of the tantalum and aluminum precursors may use a pulsing period that provides uniform coverage of a monolayer on the surface or may use a pulsing period that provides partial coverage of a monolayer on the surface during a sequence. In various embodiments, nitrogen may be used as a purging gas and a carrier gas for one or more of the sequences used in the ALD formation of tantalum aluminum oxynitride. Alternatively, hydrogen, argon gas, or other inert gases may be used as the purging gas. Excess precursor gas and reaction by-products may be removed by the purge gas. Excess precursor gas and reaction by-products may be removed by evacuation of the reaction chamber using various vacuum techniques. Excess precursor gas and reaction by-products may be removed by the purge gas and by evacuation of the reaction chamber.

**[0063]** In an embodiment, after repeating a selected number of ALD cycles, a determination is made as to whether the number of cycles equals a predetermined number to form the desired tantalum aluminum oxynitride layer. If the total number of cycles to form the desired thickness has not been completed, a number of cycles is repeated. In an embodiment, the thickness of a tantalum aluminum oxynitride layer formed by atomic layer deposition is determined by a fixed growth rate for the pulsing periods and precursors used, set at a value such as  $\text{N nm/cycle}$ , and the number of cycles conducted. In an embodiment, depending on the precursors used for ALD formation of a TaAlON film, the process is conducted in an ALD window, which is a range of temperatures in which the growth rate is substantially constant. In an embodiment, if such an ALD window is not available, the ALD process is conducted at the same set of temperatures for each ALD sequence in the process. For a desired tantalum aluminum oxynitride layer thickness,  $t$ , in an application, the ALD process is repeated for  $t/N$  total cycles. Once the  $t/N$  cycles have completed, no further ALD processing for the tantalum aluminum oxynitride layer may be terminated. In an embodiment, a tantalum aluminum oxynitride layer processed at relatively low temperatures associated with atomic layer deposition provides an amorphous layer.

**[0064]** In an embodiment, a TaAlON film may be grown to a desired thickness by repetition of a process including atomic layer deposition of layers of TaO, TaN, TaON and AlN, AlO and AlON layers followed by annealing. In an embodiment, a base thickness may be formed according to various embodiments such that forming a predetermined thickness of a TaAlON film may be conducted by forming a number of layers having the base thickness. As can be understood by one skilled in the art, determining the base thickness depends on the application and can be determined during initial processing without undue experimentation. Relative amounts of tantalum, aluminum, oxygen, and nitrogen in a TaAlON film may be controlled by regulating the relative thicknesses of the individual layers of oxides and nitrides formed. In addition, relative amounts of tantalum, aluminum, oxygen, and nitrogen in a TaAlON film may be controlled by forming a layer of TaAlON as multiple layers of different base thickness and by regulating the relative thicknesses of the individual layers of oxides and nitrides formed in each base layer prior to annealing. As can be understood by those skilled in the art, particular effective growth rates for the selected

tantalum aluminum oxynitride film can be determined during normal initial testing of the ALD system used in processing a tantalum aluminum oxynitride dielectric for a given application without undue experimentation.

#### Atomic Layer Deposition and Nitridization

**[0065]** FIG. 2 shows a flow diagram of features of an embodiment for forming TaAlON using atomic layer deposition and nitridization. At **210**, a layer of  $Ta_2O_5$  is formed using atomic layer deposition. At **220**, the layer of  $Al_2O_3$  is formed using atomic layer deposition. The order of forming  $Ta_2O_5$  and  $Al_2O_3$  may be interchanged. At **230** the alternating layers form TaAlO that is subjected to nitridization to form a TaAlON film. The nitridization may be a high temperature nitridization. In the nitridization process, active nitrogen may be introduced by microwave plasma. In the nitridization process, active nitrogen may be introduced by microwave plasma. In the nitridization process, active nitrogen may be introduced by a  $NH_3$  anneal. A high temperature nitridization is a nitridizing process that is performed at temperatures equal to or above  $500^\circ C$ . In various embodiments, TaAlO may be formed by atomic layer deposition using ALD cycles of tantalum/oxygen sequences and aluminum/oxygen sequences. Depending on the amounts of tantalum, aluminum, and oxygen to be provided in the TaAlO film, the ALD cycle can be selected from a number of different permutations of tantalum/oxygen sequences and aluminum/oxygen sequences.

**[0066]** In various embodiments, nitrogen may be used as a purging gas and a carrier gas for one or more of the sequences. Alternatively, hydrogen, argon gas, or other inert gases may be used as the purging gas. Excess precursor gas and reaction by-products may be removed by the purge gas. Excess precursor gas and reaction by-products may be removed by evacuation of the reaction chamber using various vacuum techniques. Excess precursor gas and reaction by-products may be removed by the purge gas and by evacuation of the reaction chamber.

#### Atomic Layer Deposition and Oxidation

**[0067]** FIG. 3 shows a flow diagram of features of an embodiment for forming TaAlON using atomic layer deposition and oxidation. At **310**, a layer of TaN is formed by atomic layer deposition. At **320**, a layer of AlN is formed by atomic layer deposition on the layer of TaN. TaN and AlN films may be alternately deposited in adjacent layers, in which either nitride layer may be deposited as the starting layer. At **330**, the layers of TaN and AlN are annealed. At **340**, the annealed layers of TaN and AlN are oxidized to form TaAlON. In an embodiment, the annealing and oxidation may be performed together. The layers of TaN and AlN may be annealed and oxidized by rapid thermal oxidation to form TaAlON.

**[0068]** In an embodiment, ALD TaN may be formed using a number of precursors containing tantalum to provide the tantalum to a substrate for an integrated circuit. To form tantalum nitride by ALD, a tantalum-containing precursor is pulsed onto a substrate in an ALD reaction chamber. A number of precursors containing tantalum may be used to provide the tantalum to a substrate for an integrated circuit. The tantalum-containing precursor may be a tantalum halide precursor, such as  $TaCl_5$ ,  $Ta(N-t-C_5H_{11})[N(CH_3)_2]_3$ , or tantalum ethoxide  $Ta(OC_2H_5)_5$ . In various embodiments, after pulsing

the tantalum-containing precursor and purging the reaction chamber of excess precursor and by-products from pulsing the precursor, a reactant precursor may be pulsed into the reaction chamber. The reactant precursor may be a nitrogen reactant precursor including, but not limited to, ammonia ( $NH_3$ ). Other nitrogen reactant precursors that may be used include nitrogen-containing compositions that do not include oxygen. In various embodiments, use of the individual tantalum-containing precursors is not limited to the temperature ranges of the above embodiments. Further, forming tantalum nitride by atomic layer deposition is not limited to the above-mentioned precursors. In addition, the pulsing of the tantalum precursor may use a pulsing period that provides uniform coverage of a monolayer on the surface or may use a pulsing period that provides partial coverage of a monolayer on the surface during a tantalum sequence.

**[0069]** In an embodiment, ALD AlN may be formed using a number of precursors containing aluminum to provide the aluminum to a substrate for an integrated circuit. An aluminum precursor can include a variety of precursors, such as trimethylaluminum (TMA), trisobutylaluminum (TIBA), dimethylaluminum hydride (DMAH),  $AlC_3$ , and other halogenated precursors and organometallic precursors. In an embodiment,  $H_2$  may be pulsed along with the precursor to reduce carbon contamination in the deposited film. After pulsing the aluminum-containing precursor and purging the reaction chamber of excess precursor and by-products from pulsing the precursor, a reactant precursor may be pulsed into the reaction chamber. To form AlN, a nitrogen reactant precursor is pulsed. A number of precursors containing nitrogen may be used to provide nitrogen. Such nitrogen-containing precursors include, but are not limited to, nitrogen, ammonia ( $NH_3$ ), tert-butylamine ( $C_4H_{11}N$ ), allylamine ( $C_3H_7N$ ), and 1,1-dimethylhydrazine ( $(CH_3)_2NNH_2$ ). In an embodiment, the substrate is maintained at a temperature ranging from about  $400^\circ C$ . to about  $500^\circ C$ . using tert-butylamine or allylamine as a nitrogen precursor. In an embodiment,  $NH_3$  may be pulsed with the tert-butylamine and the allylamine. The addition of  $NH_3$  may enhance the deposition rate at lower temperatures. In various embodiments, use of the individual tantalum-containing precursors is not limited to the temperature ranges of the above example embodiments. Further, forming tantalum nitride by atomic layer deposition is not limited to the above-mentioned precursors. In addition, the pulsing of the tantalum precursor may use a pulsing period that provides uniform coverage of a monolayer on the surface or may use a pulsing period that provides partial coverage of a monolayer on the surface during a tantalum/nitrogen sequence.

**[0070]** In various embodiments, nitrogen may be used as a purging gas and a carrier gas for one or more of the sequences. Alternatively, hydrogen, argon gas, or other inert gases may be used as the purging gas. Excess precursor gas and reaction by-products may be removed by the purge gas. Excess precursor gas and reaction by-products may be removed by evacuation of the reaction chamber using various vacuum techniques. Excess precursor gas and reaction by-products may be removed by the purge gas and by evacuation of the reaction chamber.

#### Atomic Layer Deposition and Annealing

**[0071]** FIG. 4 shows a flow diagram of features of an embodiment for forming TaAlON using atomic layer deposition and annealing. At **410**, a layer of TaON is formed using

atomic layer deposition. At **420**, a layer of AlON is formed using atomic layer deposition on the layer of TaON. At **430**, the layers of TaON and AlON are annealed to form a layer of TaAlON. TaON and AlON films may be alternately deposited in adjacent layers, in which either oxynitride layer may be deposited as the starting layer.

**[0072]** In an embodiment, ALD AlON may be formed using a number of precursors containing aluminum to provide the aluminum to a substrate for an integrated circuit. An aluminum precursor can include a variety of precursors, such as trimethylaluminum (TMA), trisobutylaluminum (TIBA), dimethylaluminum hydride (DMAH),  $AlCl_3$ , and other halogenated precursors and organometallic precursors. After pulsing the aluminum-containing precursor and purging the reaction chamber of excess precursor and by-products from pulsing the precursor, a reactant precursor may be pulsed into the reaction chamber. A nitrogen reactant precursor may be pulsed. A number of precursors containing nitrogen may be used to provide nitrogen. Such nitrogen-containing precursors include, but are not limited to, nitrogen, ammonia ( $NH_3$ ), tert-butylamine ( $C_4H_{11}N$ ), allylamine ( $C_3H_7N$ ), and 1,1-dimethylhydrazine ( $(CH_3)_2NNH_2$ ). After pulsing the nitrogen-containing precursor and purging the reaction chamber of excess precursor and by-products from pulsing the precursor, an oxygen reactant precursor may be pulsed into the reaction chamber. The oxygen reactant precursor may include, but is not limited to, one or more of water, atomic oxygen, molecular oxygen, ozone, hydrogen peroxide, a water-hydrogen peroxide mixture, alcohol, or nitrous oxide. In various embodiments, the order of pulsing the precursors may vary. In various embodiments, forming aluminum oxynitride by atomic layer deposition is not limited to the above-mentioned precursors. In addition, the pulsing of the precursors may use pulsing periods that provide uniform coverage of a monolayer on the surface or may use pulsing periods that provide partial coverage of a monolayer on the surface during an ALD cycle forming AlON.

**[0073]** In an embodiment, ALD TaON may be formed using a number of precursors containing tantalum to provide the tantalum to a substrate for an integrated circuit. Such tantalum-containing precursors include, but are not limited to, a tantalum halide, such as  $TaF_5$ ,  $TaCl_5$  or  $Ta(N-t-C_5H_1)[N(CH_3)_2]_3$ , and tantalum ethoxide  $Ta(OC_2H_5)_5$ . In various embodiments, after pulsing the tantalum-containing precursor and purging the reaction chamber of excess precursor and by-products from pulsing the precursor, a nitrogen reactant precursor may be pulsed into the reaction chamber. A number of precursors containing nitrogen may be used to provide nitrogen. In an embodiment,  $NH_3$  may be used as the nitrogen-containing precursor. Other nitrogen reactant precursors that may be used include nitrogen-containing compositions that do not include oxygen. In an embodiment, the nitrogen-containing precursor may also include oxygen. After pulsing the nitrogen-containing precursor and purging the reaction chamber of excess precursor and by-products from pulsing the precursor, an oxygen reactant precursor may be pulsed into the reaction chamber. The oxygen reactant precursor may include, but is not limited to, one or more of water, atomic oxygen, molecular oxygen, ozone, hydrogen peroxide, a water-hydrogen peroxide mixture, alcohol, or nitrous oxide. In various embodiments, the order of pulsing the precursors may vary. Further, forming tantalum oxynitride by atomic layer deposition is not limited to the above-mentioned precursors. In addition, the pulsing of the precursors may use puls-

ing periods that provide uniform coverage of a monolayer on the surface or may use pulsing periods that provide partial coverage of a monolayer on the surface during an ALD cycle forming TaON.

**[0074]** In various embodiments, nitrogen may be used as a purging gas and a carrier gas for one or more of the sequences. Alternatively, hydrogen, argon gas, or other inert gases may be used as the purging gas. Excess precursor gas and reaction by-products may be removed by the purge gas. Excess precursor gas and reaction by-products may be removed by evacuation of the reaction chamber using various vacuum techniques. Excess precursor gas and reaction by-products may be removed by the purge gas and by evacuation of the reaction chamber.

#### Dielectric Structures

**[0075]** In various embodiments, either before or after forming a TaAlON film, other dielectric layers such as TaO, AlO, TaON, TaON, dielectric nitride layers, dielectric metal silicates, insulating metal oxides, or combinations thereof are formed as part of a dielectric layer or dielectric stack. In some embodiments, these one or more other layers of dielectric material are provided in stoichiometric form, in non-stoichiometric form, or a combination of stoichiometric dielectric material and non-stoichiometric dielectric material. In some embodiments, depending on the application, a dielectric stack containing a TaAlON<sub>x</sub> film includes a silicon oxide layer. In some embodiments, the dielectric layer is formed as a nanolaminate. An embodiment of a nanolaminate includes a layer of a tantalum oxide and a  $Ta_yAl_xO_xN_w$  film, a layer of tantalum oxynitride and a  $Ta_yAl_xO_xN_w$  film, a layer of aluminum oxide and a  $Ta_yAl_xO_xN_w$  film, a layer of aluminum oxynitride and a  $Ta_yAl_xO_xN_w$  film, layers of tantalum oxide, aluminum oxide, tantalum oxynitride, and aluminum oxynitride along with a  $Ta_yAl_xO_xN_w$  film, or various other combinations. In an embodiment, a dielectric layer is formed substantially as the tantalum aluminum oxynitride film.

**[0076]** In various embodiments, the structure of an interface between a dielectric layer and a substrate on which it is disposed is controlled to limit the inclusion of silicon oxide, since a silicon oxide layer might reduce the effective dielectric constant of the dielectric layer. In an embodiment, the material composition and properties for an interface layer are dependent on process conditions and the condition of the substrate before forming the dielectric layer. In an embodiment, though the existence of an interface layer may effectively reduce the dielectric constant associated with the dielectric layer and its substrate, the interface layer, such as a silicon oxide interface layer or other composition interface layer, may improve the interface density, fixed charge density, and channel mobility of a device having this interface layer.

**[0077]** In an embodiment, a tantalum aluminum oxynitride layer is doped with other elements. The doping may be employed to enhance the leakage current characteristics of the dielectric layer containing the TaAlON<sub>x</sub> film by providing a disruption or perturbation of the tantalum aluminum oxynitride structure. In an embodiment, such doping is realized by substituting a sequence of one of these elements for a tantalum sequence, a  $Ta_yAl_xO_xN_{1-w}$  sequence, or various combinations of sequences. The choice for substitution may depend on the form of the tantalum aluminum oxynitride structure with respect to the relative amounts of tantalum atoms and

aluminum atoms desired in the oxide. In an embodiment, to maintain a substantially tantalum aluminum oxynitride, the amount of dopants inserted into the oxynitride are limited to a relatively small fraction of the total number of tantalum and aluminum atoms.

**[0078]** After forming a dielectric having a tantalum aluminum oxynitride layer, other material may be formed upon the tantalum aluminum oxynitride layer. In an embodiment, the other material is a conductive material. The conductive material may be used as an electrode. Such electrodes may be used as capacitor electrodes, control gates in transistors, or floating gates in floating gate transistors among others. In an embodiment, the conductive material is a metal or conductive metal nitride. In an embodiment, the conductive material is a conductive semiconductor material. In an embodiment, the conductive material is formed by ALD processes. In an embodiment, the conductive material is formed by a substitution process. In an embodiment, the conductive material is formed in a self-alignment process.

#### Atomic Layer Deposition of Conductive Layers

**[0079]** In various embodiments, a conductive layer may be deposited by atomic layer deposition on a layer of TaAlON or on a dielectric layer containing a layer of TaAlON. A metal layer may be deposited by atomic layer deposition in an ALD cycle having a halide precursor containing the metal to be deposited and a reactant precursor containing hydrogen. Metal layer formation by ALD is not limited to halide precursors and hydrogen reactant precursors. In various embodiments, precursors may be selected to form ALD conductive layers such as aluminum (Al), tungsten (W), molybdenum (Mo), gold (Au), silver (Ag), gold alloy, silver alloy, copper (Cu), platinum (Pt), rhenium (Re), ruthenium (Ru), rhodium (Rh), nickel (Ni), osmium (Os), palladium (Pd), iridium (Ir), cobalt (Co), germanium (Ge), or metallic nitrides such as WN, TiN or TaN. Formation of ALD conductive layers is not limited to the abovementioned materials.

**[0080]** In an example embodiment, a tantalum layer may be formed on a TaAlON film by atomic layer deposition using a tantalum-containing precursor. In an embodiment, a tantalum halide precursor, such as TaF<sub>5</sub> or TaCl<sub>5</sub>, may be used with hydrogen as a reactant precursor. In an embodiment, a TaCl<sub>5</sub> precursor may be used with an atomic hydrogen reactant precursor. The atomic hydrogen reactant precursor may be provided using a plasma. In an embodiment, the substrate temperature may be held at a temperature ranging from about 250° C. to about 400° C. The hydrogen reactant precursor reacts at the substrate to remove the halogen, which forms the selected tantalum halide precursor, leaving tantalum on the substrate surface. After pulsing a tantalum-containing precursor and after pulsing its reactant precursor, the reaction chamber may be purged of excess precursor and/or by-products. In various embodiments, use of the individual tantalum-containing precursors is not limited to the temperature ranges of the above example embodiments. Further, forming tantalum by atomic layer deposition is not limited to the abovementioned precursors. In addition, the pulsing of the tantalum precursor may use a pulsing period that provides uniform coverage of a monolayer on the surface or may use a pulsing period that provides partial coverage of a monolayer on the surface. The tantalum layer may be structured as one or more monolayers.

The tantalum layer may have a thickness ranging from a monolayer to thousands of angstroms or more.

#### Metal Substitution

**[0081]** FIGS. 5A-5E illustrate an embodiment of a process for forming a metal substituted electrode in place of a previously deposited material on a dielectric containing TaAlON. Though a transistor is discussed with reference to FIGS. 5A-5E, such a process may be used with respect to other embodiments of device configurations. FIG. 5A shows a substrate 501 and shallow trench isolation (STI) regions 502. The substrate 501 can be a semiconductor wafer as well as structures having one or more insulative, semi-insulative, conductive, or semiconductive layers and materials. Thus, for example, the substrate can include silicon-on-insulator, silicon-on-sapphire, and other structures upon which semiconductor devices are formed.

**[0082]** FIG. 5B further shows a gate dielectric layer 503 formed on the substrate 501, and a gate substitutable layer 504 formed on the gate dielectric layer 503. The gate dielectric layer may include a dielectric layer containing TaAlON in addition to other insulative material or a dielectric layer essentially of TaAlON. The use of such a high-κ dielectric increases the capacitance, which may be useful for nanoscale integrated circuits. In various embodiments the gate dielectric includes stacked layers comprising one or more high-κ dielectric materials. As described in more detail below, the material of the gate substitutable layer 504 is selected with respect to the desired gate material to allow the gate material to replace the gate substitutable layer. This process forms a gate of the desired gate metal where the substitutable material was positioned on the gate dielectric.

**[0083]** As shown in FIG. 5C, portions of the gate dielectric layer 503 and the gate substitutable layer 504 may be removed to define a gate 505. Sidewalls or spacers 506 are formed along the gate 505. Source/drain regions 507 are also formed. Source/drain regions 507 can be formed using conventional ion implantation and subsequent annealing. These annealing temperatures can pose problems for aluminum gates and other metal gates that have melting temperatures less than the anneal temperature for the source/drain regions.

**[0084]** FIG. 5D shows an insulative fill layer 508 provided to match the thickness of the gate stack. A planarization procedure, such as chemical-mechanical polishing, can be used to provide an even surface across the fill layer 508 and the gate substitutable layer 504. A metal layer 509, perhaps forming a gate material, may be deposited over the gate substitutable layer 504 and the fill layer 508. The metal layer 509 is also referred to herein as a layer of gate material. Various deposition processes, such as evaporation, sputtering, chemical vapor deposition, or atomic layer deposition, may be used to form the metal layer 509. The volume of layer 509 may be significantly larger than the volume of the substitutable material left on the wafer.

**[0085]** After the metal layer 509 is deposited on the gate substitutable layer, a metal-substitution reaction may be induced. The reaction can be provided by annealing the structure in a non-oxidizing atmosphere such as a nitrogen gas or a forming gas. The heating urges diffusion or dissolution of the intended gate material in metal layer 509 for the substitutable material 504. The substitution process is bounded by the spacers 506 and the gate dielectric 503.

**[0086]** At the conclusion of the substitution reaction, the residual metal of layer 509 and the substitutable material may

be removed such as may be achieved using conventional planarization. FIG. 5E shows the resulting low-resistance gate structure. The illustrated structure includes a metal substituted gate 510 formed by the substitution of the metal of layer 509. The metal substituted gate 510 may include a small amount of the gate substitutable material that did not diffuse above the planarization level 511. Such small amounts of the gate substitutable material do not significantly affect the conductivity of the metal substituted gate 510, and thus do not significantly affect the performance of the device.

[0087] Drain and source contacts (not shown) can be formed, as well as interconnects to other transistors or components, using conventional techniques. Another heat treatment may occur after packaging the structures (e.g., an integrated circuit in a protective housing in an attempt to minimize the resistivity of the metal gate contacts and other metal interconnections.

[0088] The metal gate substitution technique, as disclosed herein, can be applied to MOS devices, as generally illustrated in FIG. 5E, as well as to form metal floating gates and/or metal control gates in nonvolatile devices. Additionally, various high- $\kappa$  dielectrics having a TaAlON film can be used between the floating gate and the substrate, and between the control gate and the floating gate in these nonvolatile devices.

[0089] FIG. 6 illustrates a flow diagram of features of an embodiment of a metal substitution technique. At 612, a gate dielectric is formed on a substrate. The gate dielectric may include a TaAlON film. At 613, a layer of gate substitutable material is formed on the gate dielectric. Examples of gate substitutable material include polysilicon, germanium, silicon-germanium, and carbon. At 614, source/drain regions are formed. A layer of gate material is formed at 615 on the gate substitutable material. Examples of such metals include gold, silver, and aluminum. Other metals may be used. At 616, the gate material is substituted for the layer of gate substitutable material.

[0090] A metal substitution reaction substitutes or replaces the substitutable material (e.g. silicon, germanium, silicon-germanium, carbon) with a metal. After the substitution, the resulting gate structure includes substantially all of the desired metal. Small amounts of the substitutable material may remain in the gate structure. The substitution reaction can be induced by heating the integrated circuit assembly to a desired temperature in a vacuum, nitrogen, argon, forming gas or other non-oxidizing atmosphere. Heating causes diffusion of the metal layer 509 into the substitutable layer. The annealing temperature for the substitution is less than the eutectic (lowest melting) temperature of materials involved in the substitution for the reaction for substitution to occur. In an embodiment, to form a gold gate, a metal layer may be formed from gold and annealed at approximately 300° C. to substitute the gold for a silicon substitutable structure. In an embodiment, to form a silver gate, a metal layer may be formed from silver and annealed at approximately 500-600° C. to substitute the silver for a silicon substitutable structure. A polysilicon and germanium substitutable material may be used, which reduces the anneal temperature.

[0091] According to various embodiments, the gate substitutable material 504 shown in FIGS. 5A-5E includes polysilicon. In some embodiments, the gate substitutable material includes germanium. Some embodiments use silicon-germanium with a percentage of silicon in the range from 0% to 100% as the gate substitutable material 504. Some embodi-

ments use carbon as the gate substitutable material 504. With respect to various embodiments which use polysilicon, germanium, or silicon-germanium as the gate substitutable material 504, a replacement metal for the substituted gate includes aluminium, alloy of aluminium, copper, alloy of copper, tantalum, alloy of tantalum, silver, gold, an alloy of silver, an alloy of gold as the replacement metal, or combinations thereof. In various embodiments, with carbon used as the gate substitutable material 504, a replacement metal for the substituted gate may include alloys of aluminium, gold, silver, an alloy of gold, an alloy of silver, copper, alloy of copper, tantalum, alloys of tantalum, alloys of tungsten, platinum, rhenium, ruthenium, rhodium, nickel, osmium, palladium, iridium, cobalt, germanium, or combinations thereof. [0092] Various embodiments form an integrated circuit structure using two or more substitution reactions. Relatively higher temperature substitution processes can be performed before relatively lower temperature substitution processes. One application for multiple substitution reactions is to independently adjust work functions of NMOS and PMOS transistors in CMOS integrated circuits. Multiple substitution reactions are not limited to this CMOS integrated circuit application. Additional information regarding metal substitution can be found in U.S. patent application Ser. No. 11/176, 738 filed Jul. 7, 2005, entitled "METAL-SUBSTITUTED TRANSISTOR GATES," which is herein incorporated by reference.

#### Self Aligned Metal Technique

[0093] FIGS. 7A-7D illustrate an embodiment of a process for forming a self aligned conductive layer such as a metal gate for a transistor structure. FIG. 7A illustrates a high- $\kappa$  gate dielectric 710 containing TaAlON formed on a substrate 701. The substrate 701 may include a semiconductor wafer as well as structures having one or more insulative, semi-insulative, conductive, or semiconductive layers and materials. Thus, for example, the substrate can include silicon-on-insulator, silicon-on-sapphire, and other structures upon which semiconductor devices are formed.

[0094] In FIG. 7A, a sacrificial gate 703 may be formed of amorphous carbon on the high- $\kappa$  gate dielectric 710. In various embodiments, an etch barrier 708 is formed over the sacrificial gate and the dielectric. The etch barrier 708 includes silicon nitride or aluminium oxide, and can be formed using a deposition process, according to various embodiments. Sacrificial sidewall spacers 706 are added adjacent the sacrificial gate 703. In various embodiments, the spacers 706 are formed of amorphous carbon by deposition and conventional direct etch techniques. An ion implantation 730 and high temperature anneal are used to form source/drain regions 702 in areas defined by the sacrificial sidewall spacers 706. These annealing temperatures can pose problems for aluminum gates and other metal gates that have melting temperatures less than the anneal temperature for the source/drain regions.

[0095] In FIG. 7B, the sacrificial sidewall spacers (706 in FIG. 7A) have been removed. Various embodiments use a plasma oxidation process to remove the sacrificial sidewall spacers. In addition, the etch barrier (708 in FIG. 7A) has been removed. In various embodiments, a light dose ion implantation 740 is used to form source/drain extensions 742 in the substrate 701. The extensions 742 can be annealed at lower temperatures and in shorter times than the more heavily doped source/drain regions 702. According to various

embodiments, source/drain extensions for the transistor may be formed with doping the substrate to a depth of 30 nm or less.

**[0096]** In FIG. 7C, conventional or non-carbon sidewall spacers **756** are formed and the whole structure is back filled with an oxide fill **758**, such as silicon dioxide, and planarized. A planarization procedure, such as chemical-mechanical polishing, can be used to provide an even surface. In various embodiments, the conventional sidewall spacers are formed with silicon nitride.

**[0097]** In FIG. 7D, the sacrificial gate (**703** in FIG. 7C) is removed and replaced by the deposition of a metal layer **760**. In various embodiments, the sacrificial gate is removed using a plasma oxidation process. Various deposition processes, such as evaporation, sputtering, chemical vapor deposition, or atomic layer deposition, may be used to form the metal layer **760**. The structure is planarized (not shown) using a planarization procedure, such as chemical-mechanical polishing, resulting in the self aligned metal gate over the high- $\kappa$  gate dielectric insulator **710**. Drain and source contacts (not shown) can be formed, as well as interconnects to other transistors or components, using conventional techniques. Another heat treatment may occur after packaging the integrated circuit in a protective housing in an attempt to minimize the resistivity of the metal gate contacts and other metal interconnections.

**[0098]** FIGS. 7A-7D illustrate two replacement processes for the formation of planar self aligned metal gate transistors, one for disposable sidewall spacers and the other for the gate material itself. The metal gate replacement technique, as disclosed herein, can be applied to MOS devices, as generally illustrated in FIGS. 7A-7D, as well as to form metal floating gates and/or metal control gates in nonvolatile devices. Additionally, various high- $\kappa$  dielectrics can be used between the floating gate and the substrate, and between the control gate and the floating gate in these nonvolatile devices.

**[0099]** FIG. 8 illustrates an embodiment of a method **800** for forming a self aligned metal gate on high- $\kappa$  gate dielectrics containing TaAlON. According to various embodiments, a high- $\kappa$  gate dielectric containing TaAlON is formed on a substrate, at **802**. At **804**, a sacrificial carbon gate is formed on the gate dielectric. At **806**, sacrificial carbon sidewall spacers are formed adjacent to the sacrificial carbon gate. At **808** source/drain regions for the transistor are formed, using the sacrificial carbon sidewall spacers to define the source/drain regions. The sacrificial carbon sidewall spacers are replaced with non-carbon sidewall spacers at **810**. At **812**, the sacrificial carbon gate is replaced with a desired metal gate material to provide the desired metal gate material on the gate dielectric.

**[0100]** In various embodiments, source/drain extensions may be formed after removing the carbon sidewall spacers and before replacing with non-carbon sidewall spacers. An etch barrier can be used in various embodiments to separate the sacrificial carbon gate from the sacrificial carbon sidewall spacers. In various embodiments, the carbon sacrificial gate may be replaced with aluminum (Al), tungsten (W), molybdenum (Mo), gold (Au), silver (Ag), gold alloy, silver alloy, copper (Cu), platinum (Pt), rhenium (Re), ruthenium (Ru), rhodium (Rh), nickel (Ni), osmium (Os), palladium (Pd), iridium (Ir), cobalt (Co), germanium (Ge), or metallic nitrides such as WN, TiN or TaN covered by metals. The high- $\kappa$  gate dielectric formed at **802** may be one of a number of high- $\kappa$  gate dielectrics containing TaAlON.

**[0101]** In various embodiments, construction of an integrated circuit structure includes a dielectric containing TaAlON on which is disposed a self-aligned metal electrode. Additional information regarding a self-aligned metal electrode used as a transistor gate can be found in U.S. patent application Ser. No. 11/216,375, filed 31 Aug. 2005, entitled "SELF ALIGNED METAL GATES ON HIGH-K DIELECTRICS," which is herein incorporated by reference.

#### Device Structures

**[0102]** FIG. 9 illustrates an embodiment of a wafer **940** containing integrated circuits having one or more dielectric layers that include a tantalum aluminum oxynitride film. Conductive electrodes may be disposed on such dielectrics in a number of configurations such as capacitors, transistors, or elements of a memory. The conductive electrodes may be metal electrodes, conductive metal nitride electrodes, and/or conductive metal oxide electrodes. The conductive electrodes may be atomic layer deposited electrodes. Metal electrodes may be metal substituted electrodes and/or self aligned metal electrodes formed in accordance with the teachings of embodiments discussed herein. A common wafer size is 8 inches in diameter. However, wafers are capable of being fabricated in other sizes, and embodiments of wafers containing a tantalum aluminum oxynitride film are not limited to a particular size. A number of dies can be formed on a wafer. A die **941** is an individual pattern on a substrate that contains circuitry to perform a specific function. A semiconductor wafer typically contains a repeated pattern of such dies containing the same functionality. A die is typically packaged in a protective casing (not shown) with leads extending therefrom (not shown) providing access to the circuitry of the die for communication and control.

**[0103]** Applications containing electronic devices having dielectric layers containing tantalum aluminum oxynitride film include electronic systems for use in memory modules, device drivers, power modules, communication modems, processor modules, and application-specific modules, which may include multilayer, multichip modules. Such dielectric layers may be configured as multiple layers containing at least one layer of TaAlON or configured substantially as a TaAlON layer. In addition, such dielectric layers may be configured in contact with a metal electrode. For a given applied voltage, the magnitude (or strength) of an electric field across the TaAlON layer is based on its dielectric constant and its thickness. In general, the strength of such an electric field decreases as the value of the dielectric constant increases, and also as dielectric thickness increases. In some embodiments, the thickness of the tantalum aluminum oxynitride layer may be adjusted to obtain a specified electric field between one or more electrodes. In various embodiments, the dielectric constant of the tantalum aluminum oxynitride layer may be adjusted to obtain a specified electric field between one or more electrodes. In some embodiments, the dielectric constant and thickness of the tantalum aluminum oxynitride layer in combination may be adjusted to obtain a specified electric field between one or more electrodes. The electric field strength across a TaAlON layer may be adjusted as desired to achieve a particular circuit function or circuit characteristic. In some embodiments, application of a voltage to the electrode induces or establishes an electric field or charge field across the insulator. In various embodiments the charge field is removed by removing the voltage. In some embodiments the electric field is retained after the voltage at the

electrode is removed. Such circuitry can be a subcomponent of a variety of electronic systems, such as a clock, a television, a cell phone, a personal computer, an automobile, an industrial control system, an aircraft, and others.

**[0104]** FIG. 10 shows an embodiment of a transistor 1000 having a dielectric layer 1040 containing a  $Ta_xAl_zO_xN_w$  film. In an embodiment, transistor 1000 includes a source region 1020 and a drain region 1030 in a silicon-based substrate 1010 where source and drain regions 1020, 1030 are separated by a body region 1032. Body region 1032 defines a channel having a channel length 1034. In an embodiment, a gate dielectric 1040 is disposed on substrate 1010 with gate dielectric 1040 formed as a dielectric layer containing  $Ta_xAl_zO_xN_w$ . In an embodiment, gate dielectric 1040 is realized as a dielectric layer formed substantially of  $Ta_xAl_zO_xN_w$ . In an embodiment, gate dielectric 1040 is constructed as multiple dielectric layers, that is, as a dielectric stack, containing at least one  $Ta_xAl_zO_xN_w$  film and one or more layers of insulating material other than tantalum aluminum oxynitride film. In an embodiment, the  $Ta_xAl_zO_xN_w$  film is structured as one or more monolayers. An embodiment of a  $Ta_xAl_zO_xN_w$  film is formed using atomic layer deposition. In an embodiment, gate dielectric 1040 may be realized as a gate insulator in a silicon-based structure.

**[0105]** In an embodiment, a gate 1050 is formed on and contacts gate dielectric 1040. In an embodiment, gate 1050 includes conductive material. In an embodiment, gate 1050 includes a conductive material structured as one or more monolayers. In an embodiment, the conductive material layer is an ALD conductive material layer. In an embodiment, the conductive material layer is a substituted metal layer. In an embodiment, the conductive material layer is a self-aligned metal layer. In an embodiment, the thickness of the conductive layer ranges from a monolayer to thousands of angstroms or more.

**[0106]** An interfacial layer may form between body region 1032 and gate dielectric 1040. In an embodiment, an interfacial layer is limited to a relatively small thickness compared to gate dielectric 1040, or to a thickness significantly less than gate dielectric 1040 as to be effectively eliminated. In an embodiment, forming the substrate and the source and drain regions is performed using standard processes known to those skilled in the art. In an embodiment, the sequencing of the various elements of the process for forming a transistor is conducted with fabrication processes known to those skilled in the art. In an embodiment, transistor 1000 is a MOSFET transistor. In an embodiment, transistor 1000 is a germanium MOSFET structure. In an embodiment, transistor 1000 is a silicon MOSFET structure. In an embodiment, transistor 1000 is a silicon-germanium (SiGe) MOSFET structure. In an embodiment, transistor 1000 is a gallium arsenide MOSFET structure. In an embodiment, transistor 1000 is a NMOS transistor. In an embodiment, transistor 1000 is a PMOS transistor. Transistor 1000 is not limited to the arrangement illustrated in FIG. 10. For example, transistor 1000 may be structured as a vertical transistor. In an embodiment, use of a gate dielectric containing tantalum aluminum oxynitride is not limited to silicon-based substrates, but is used with a variety of semiconductor substrates.

**[0107]** FIG. 11 shows an embodiment of a floating gate transistor 1100 having a dielectric layer containing a  $Ta_xAl_zO_xN_w$  film. In an embodiment, the  $Ta_xAl_zO_xN_w$  film is structured as one or more monolayers. In an embodiment, the  $Ta_xAl_zO_xN_w$  film is formed using atomic layer deposition

techniques. In an embodiment, transistor 1100 includes a silicon-based substrate 1110 with a source 1120 and a drain 1130 separated by a body region 1132. Body region 1132 between source 1120 and drain 1130 defines a channel region having a channel length 1134. Located above body region 1132 is a stack 1155 including a gate dielectric 1140, a floating gate 1152, a floating gate dielectric 1142 (inter-grate dielectric 1142), and a control gate 1150. An interfacial layer may form between body region 1132 and gate dielectric 1140. In an embodiment, such an interfacial layer is limited to a relatively small thickness compared to gate dielectric 1140, or to a thickness significantly less than gate dielectric 1140 as to be effectively eliminated.

**[0108]** In an embodiment, gate dielectric 1140 includes a dielectric containing an atomic layer deposited  $Ta_xAl_zO_xN_w$  film formed in embodiments similar to those described herein. In an embodiment, gate dielectric 1140 is realized as a dielectric layer formed substantially of  $Ta_xAl_zO_xN_w$ . In an embodiment, gate dielectric 1140 is a dielectric stack containing at least one  $Ta_xAl_zO_xN_w$  film and one or more layers of other insulating materials.

**[0109]** In an embodiment, floating gate 1152 is formed on and contacts gate dielectric 1140. In an embodiment, floating gate 1152 includes conductive material. In an embodiment, floating gate 1152 is structured as one or more monolayers. In an embodiment, floating gate 1152 is an ALD layer. In an embodiment, floating gate 1152 is a substituted metal layer. In an embodiment, floating gate 1152 is a self-aligned metal layer. In an embodiment, the thickness of the floating gate layer ranges from a monolayer to thousands of angstroms or more.

**[0110]** In an embodiment, floating gate dielectric 1142 includes a dielectric containing a  $Ta_xAl_zO_xN_w$  film. In an embodiment, the  $Ta_xAl_zO_xN_w$  film is structured as one or more monolayers. In an embodiment, the  $Ta_xAl_zO_xN_w$  is formed using atomic layer deposition techniques. In an embodiment, floating gate dielectric 1142 is realized as a dielectric layer formed substantially of  $Ta_xAl_zO_xN_w$ . In an embodiment, floating gate dielectric 1142 is a dielectric stack containing at least one  $Ta_xAl_zO_xN_w$  film and one or more layers of other insulating materials.

**[0111]** In an embodiment, control gate 1150 is formed on and contacts floating gate dielectric 1142. In an embodiment, control gate 1150 includes conductive material. In an embodiment, control gate 1150 is structured as one or more monolayers. In an embodiment, the control gate 1150 is an ALD layer. In an embodiment, control gate 1150 is a substituted metal layer. In an embodiment, control gate 1150 is a self-aligned metal layer. In an embodiment, the thickness of the control gate layer 1150 ranges from a monolayer to thousands of angstroms or more. In an embodiment, control gate 1150 is structured as one or more monolayers.

**[0112]** In an embodiment, both gate dielectric 1140 and floating gate dielectric 1142 are formed as dielectric layers containing a  $Ta_xAl_zO_xN_w$  film structured as one or more monolayers. In an embodiment, control gate 1150 and floating gate 1152 are formed as conductive layers. In an embodiment, the control gate 1150 and floating gate 1152 are structured as one or more monolayers. In an embodiment, control gate 1150 and floating gate 1152 are ALD layers. In an embodiment, control gate 1150 and floating gate 1152 are substituted metal layers. In an embodiment, control gate 1150 and floating gate 1152 are self-aligned metal layers. In an embodiment, gate dielectric 1140, floating gate dielectric

**1142**, control gate **1150**, and floating gate **1152** are realized by embodiments similar to those described herein, with the remaining elements of the transistor **1100** formed using processes known to those skilled in the art. In an embodiment, gate dielectric **1140** forms a tunnel gate insulator and floating gate dielectric **1142** forms an inter-gate insulator in flash memory devices, where gate dielectric **1140** and floating gate dielectric **1142** may include a tantalum aluminum oxynitride film structured as one or more monolayers. Floating gate transistor **1100** is not limited to the arrangement illustrated in FIG. 11. For example, floating gate transistor **1100** may be structured as a vertical transistor. Such structures are not limited to silicon-based substrates, but may be used with a variety of semiconductor substrates, such as for but not limited to germanium floating gate transistors, SiGe floating gate transistors, and gallium arsenide floating gate transistors.

[0113] FIG. 12 shows an embodiment of a capacitor **1200** having a dielectric layer containing a tantalum aluminum oxynitride film **1220** and having an electrode **1230**. Embodiments of a tantalum aluminum oxynitride film **1220** structured as one or more monolayers may also be applied to capacitors in various integrated circuits, memory devices, and electronic systems. In an embodiment for a capacitor **1200** illustrated in FIG. 12, a method includes forming a first conductive layer **1210**, forming a dielectric layer **1220** containing a tantalum aluminum oxynitride film structured as one or more monolayers on first conductive layer **1210**, and forming a second conductive layer **1230** on dielectric layer **1220**. In various embodiments, second conductive layer **1230**, first conductive layer **1210**, or both second and first conductive layers **1230**, **1210** are ALD conductive material layers, substituted metal layers, self-aligned metal layers, or a combination thereof. In an embodiment, the thickness of the conductive layer ranges from a monolayer to thousands of angstroms or more.

[0114] In an embodiment, dielectric layer **1220**, containing a  $Ta_xAl_yO_zN_w$  film, and conductive layers **1210**, **1220** are formed using various embodiments described herein. In an embodiment, dielectric layer **1220** is realized as a dielectric layer formed substantially of  $Ta_xAl_yO_zN_w$ . In an embodiment, dielectric layer **1220** is a dielectric stack containing at least one  $Ta_xAl_yO_zN_w$  film and one or more layers of other insulating materials. Embodiments for a tantalum aluminum oxynitride film may include, but are not limited to, a capacitor in a DRAM and capacitors in analog, radio frequency (RF), and mixed signal integrated circuits. Mixed signal integrated circuits are integrated circuits that may operate with digital and analog signals.

[0115] FIG. 13 depicts an embodiment of a dielectric structure **1300** having multiple dielectric layers **1305-1**, **1305-2** . . . **1305-N**, in which at least one layer is a tantalum aluminum oxynitride layer. In an embodiment, layers **1310** and **1320** provide means to contact dielectric layers **1305-1**, **1305-2** . . . **1305-N**. In an embodiment, each layer **1310**, **1320** or both layers are conductive layers. In an embodiment, layers **1310** and **1320** are electrodes forming a capacitor. In an embodiment, layer **1310** is a body region of a transistor with layer **1320** being a gate. In an embodiment, layer **1310** is a floating gate electrode with layer **1320** being a control gate.

[0116] In an embodiment, dielectric structure **1300** includes one or more layers **1305-1**, **1305-2** . . . **1305-N** as dielectric layers other than a TaAlON layer, where at least one layer is a TaAlON layer. In an embodiment, dielectric layers **1305-1**, **1305-2** . . . **1305-N** include a  $Ta_2O_5$  layer, a  $Al_2O_3$

layer, a TaON layer, a AlON layer, or various combinations of these layers. In an embodiment, dielectric layers **1305-1**, **1305-2** . . . **1305-N** include an insulating metal oxide layer. In an embodiment, dielectric layers **1305-1**, **1305-2** . . . **1305-N** include an insulating nitride layer. In an embodiment, dielectric layers **1305-1**, **1305-2** . . . **1305-N** include an insulating oxynitride layer. In an embodiment, dielectric layers **1305-1**, **1305-2** . . . **1305-N** include an insulating silicate layer.

[0117] Various embodiments for a dielectric layer containing a tantalum aluminum oxynitride film structured as one or more monolayers may enhance device performance by providing devices with reduced leakage current. Such improvements in leakage current characteristics may be attained by forming one or more layers of a tantalum aluminum oxynitride in a nanolaminate structure with other metal oxides, non-metal-containing dielectrics, or combinations thereof. The transition from one layer of the nanolaminate to another layer of the nanolaminate can disrupt an ordered structure in the nanolaminate stack. The term "nanolaminate" means a composite film of ultra thin layers of two or more materials in a layered stack. Typically, each layer in a nanolaminate has a thickness of less than 20 nanometers and may have a thickness less than a monolayer. In an embodiment, a  $Ta_2O_5$ /TaAlON nanolaminate contains alternating layers of a  $Ta_2O_5$  and TaAlON. In an embodiment, a TaON/TaAlON nanolaminate contains alternating layers of a TaON and TaAlON. In an embodiment, a AlON/TaAlON nanolaminate contains alternating layers of AlON and TaAlON. In an embodiment, a  $Al_2O_3$ /TaAlON nanolaminate contains alternating layers of  $Al_2O_3$  and TaAlON. In an embodiment, a  $Ta_2O_5$ /AlON/ $Al_2O_3$ /TaON/TaAlON nanolaminate contains various permutations of tantalum oxide layers, aluminum oxynitride layers, aluminum oxide layers, tantalum oxynitride layers, and tantalum aluminum oxynitride layers.

[0118] In an embodiment, the sequencing of the layers in dielectric structure **1300** structured as a nanolaminate depends on the application. The effective dielectric constant associated with nanolaminate structure **1300** is that attributable to N capacitors in series, where each capacitor has a thickness defined by the thickness and composition of the corresponding layer. In an embodiment, by selecting each thickness and the composition of each layer, a nanolaminate structure may be formed with a predetermined dielectric constant. Embodiments for structures such as nanolaminate structure **1300** may be used as nanolaminate dielectrics in flash memory devices as well as other integrated circuits. In an embodiment, a layer of the nanolaminate structure **1300** is used to store charge in a flash memory device. The charge storage layer of a nanolaminate structure **1300** in a flash memory device may be a silicon oxide layer.

[0119] In an embodiment, transistors, capacitors, and other devices include dielectric films containing a layer of a tantalum aluminum oxynitride composition with an electrode. In an embodiment, the tantalum aluminum oxynitride layer is an atomic layer deposited tantalum aluminum oxynitride layer. In an embodiment, the electrode is an atomic layer deposited electrode. In an embodiment, the electrode is a substituted metal layer. In an embodiment, the electrode is a self-aligned metal layer. In an embodiment, dielectric films containing a tantalum aluminum oxynitride layer with an electrode are implemented into memory devices and electronic systems including information handling devices. In various embodiments, information handling devices include wireless systems, telecommunication systems, and computers. In various

embodiments, such electronic devices and electronic apparatus are realized as integrated circuits.

[0120] FIG. 14 illustrates a block diagram for an electronic system 1400 with one or more devices having a dielectric structure including a  $Ta_yAl_zO_xN_w$  film with an electrode. Electronic system 1400 includes a controller 1405, a bus 1415, and an electronic device 1425, where bus 1415 provides electrical conductivity between controller 1405 and electronic device 1425. In various embodiments, controller 1405 includes an embodiment of a  $Ta_yAl_zO_xN_w$  film with an electrode. In various embodiments, electronic device 1425 includes an embodiment of a  $Ta_yAl_zO_xN_w$  film with an electrode. In various embodiments, controller 1405 and electronic device 1425 include embodiments of a  $Ta_yAl_zO_xN_w$  film with an electrode. In an embodiment, electronic system 1400 includes, but is not limited to, fiber optic systems, electro-optic systems, telecommunication systems, wireless information handling systems such as cell phones and PDAs (personal digital assistants), GPS (global positioning system) receivers, data telemetry units, computer systems such as personal computers, MP3 (MPEG-1 Audio Layer-3) players, servers and routers, and control systems for use in automobiles such as emission controls, automatic brakes, and entertainment systems.

[0121] FIG. 15 depicts a diagram of an embodiment of a system 1500 having a controller 1505 and a memory 1525. In an embodiment, controller 1505 includes a TaAlON film with an electrode. In an embodiment, memory 1525 includes a TaAlON film structured as one or more monolayers with an electrode. In an embodiment, controller 1505 and memory 1525 each include a TaAlON film with an electrode. In an embodiment, system 1500 also includes an electronic apparatus 1535 and a bus 1515, where bus 1515 provides electrical conductivity between controller 1505 and electronic apparatus 1535 and between controller 1505 and memory 1525. In an embodiment, bus 1515 includes an address bus, a data bus, and a control bus, each independently configured. In an alternative embodiment, bus 1515 uses common conductive lines for providing one or more of address, data, or control, the use of which is regulated by controller 1505. In an embodiment, electronic apparatus 1535 is additional memory configured in a manner similar to memory 1525. In an embodiment, additional peripheral device or devices 1545 are coupled to bus 1515. In an embodiment, peripheral devices 1545 include displays, additional storage memory, or other control devices that may operate in conjunction with controller 1505. In an alternative embodiment, peripheral devices 1545 may include displays, additional storage memory, or other control devices that may operate in conjunction with memory 1525, or controller 1505 and memory 1525. In an embodiment, controller 1505 is a processor. In an embodiment, one or more of controller 1505, memory 1525, bus 1515, electronic apparatus 1535, or peripheral devices 1545 include an embodiment of a dielectric layer having a TaAlON film structured as one or more monolayers with an electrode. In an embodiment, system 1500 includes, but is not limited to, information handling devices, telecommunication systems, and computers.

[0122] In an embodiment, memory 1525 is realized as a memory device containing a TaAlON film structured as one or more monolayers with an electrode. In an embodiment, a TaAlON structure with a conductive layer is formed in a memory cell of a memory array. In an embodiment, such a structure is formed in a capacitor in a memory cell of a

memory array. In an embodiment, such a structure is formed in a transistor in a memory cell of a memory array. In an embodiment, it will be understood that embodiments are equally applicable to any size and type of memory circuit and are not intended to be limited to a particular type of memory device. Memory types include a DRAM, SRAM (Static Random Access Memory) or Flash memories. Additionally, the DRAM could be a synchronous DRAM commonly referred to as SGRAM (Synchronous Graphics Random Access Memory), SDRAM (Synchronous Dynamic Random Access Memory), SDRAM II, and DDR SDRAM (Double Data Rate SDRAM), as well as other emerging DRAM technologies.

[0123] Although specific embodiments have been illustrated and described herein, it will be appreciated by those of ordinary skill in the art that any arrangement that is calculated to achieve the same purpose may be substituted for the specific embodiments shown. It is to be understood that the above description is intended to be illustrative, and not restrictive, and that the phraseology or terminology employed herein is for the purpose of description and not of limitation. Combinations of the above embodiments and other embodiments will be apparent to those of skill in the art upon studying the above description.

What is claimed is:

1. An integrated circuit comprising:
  - memory, comprising flash memory, the flash memory including a plurality of storage capacitor elements, each of the storage capacitor elements having at least one TaAlON layer interposed between at least two electrodes.
2. The integrated circuit of claim 1, wherein the memory includes a plurality of silicon-based CMOS transistors.
3. The integrated circuit of claim 1, wherein the memory includes at least one of a PMOS and a NMOS transistor.
4. The integrated circuit of claim 3, wherein the at least one of a PMOS and a NMOS transistor includes a TaAlON gate dielectric.
5. An integrated circuit comprising:
  - a plurality of insulated gate field effect transistors, each of the plurality including one or more gate dielectric layers;
  - a memory, at least a portion of the memory including a one or more capacitive storage elements, wherein the capacitive storage elements include a TaAlON dielectric layer; and
  - a plurality of conductive layers, wherein at least one of the plurality of conductive layers is supported by at least a portion of the TaAlON dielectric layer.
6. The integrated circuit of claim 1, wherein at least a portion of the one or more gate dielectric layers includes TaAlON.
7. The integrated circuit of claim 1, wherein a portion of the plurality of insulated gate field effect transistors is electrically coupled to at least a portion of the one or more capacitive storage elements.
8. The integrated circuit of claim 1, wherein a portion of the plurality of insulated gate field effect transistors is configured to comprise a mixed signal circuit.
9. The integrated circuit of claim 1, wherein a portion of the plurality of insulated gate field effect transistors is configured to comprise an analog circuit.
10. The integrated circuit of claim 1, wherein the memory includes a DRAM or a flash memory.

- 11.** An electronic device comprising:  
a conductive channel located between a first region and a second region, wherein the electrical conductivity of the channel is modulated by a voltage; and  
at least one composite insulator comprising a refractory metal and a non-refractory metal, the composite insulator configured to electrically couple the first region and the second region using conductive channel.
- 12.** The electronic device of claim 11, wherein the at least one composite insulator includes at least one of a refractory metal oxynitride and a non-refractory metal oxynitride.
- 13.** The electronic device of claim 12, wherein the at least one composite insulator is an amorphous insulator.
- 14.** The electronic device of claim 11, wherein the at least one composite insulator includes one or more  $Ta_yAl_zO_xN_w$  layers, where y, z, x, w are integer values, and where y is 1 or 2, z is 1 or 2, x is 0, 1, 3 or 5, and w is 0 or 1.
- 15.** The electronic device of claim 14, wherein at least one of the one or more  $Ta_yAl_zO_xN_w$  layers is amorphous.
- 16.** The electronic device of claim 11, wherein the at least one composite insulator includes a TaAlON tunnel insulator layer.
- 17.** A storage capacitor comprising:  
two or more electrode layers; and  
one or more dielectric layers, at least one of the one or more dielectric layers including at least one refractory metal oxynitride layer, wherein at least a portion of the at least one refractory metal oxynitride layer is interposed between the two or more electrode layers.
- 18.** The storage capacitor of claim 17, wherein the refractory metal oxynitride layer includes TaAlON.
- 19.** The storage capacitor of claim 17, wherein the one or more dielectric layers includes a TaAlON tunnel layer.
- 20.** The storage capacitor of claim 17, wherein the one or more dielectric layers includes a nanolaminate composite.
- 21.** The storage capacitor of claim 20, wherein the nanolaminate structure includes at least one of a  $Ta_2O_5/Al_2O_3$ , a TaON/AION, a  $Ta_2O_5/AlN$ , a  $TaN/Al_2O_3$ , and a  $TaN/AlN$  structure.
- 22.** The storage capacitor of claim 20, wherein the two or more electrodes are configured to form at least a portion of a flash memory.
- 23.** A memory element comprising:  
two or more electrode layers;  
one or more insulator layers, at least one of the one or more insulator layers including a composite dielectric material; and  
wherein at least a portion of the composite material is configured to couple electric charge between the two or more electrodes.
- 24.** The memory element of claim 23, wherein the composite material includes a metal oxynitride.
- 25.** The memory element of claim 24, wherein the metal oxynitride is a non-stoichiometric metal oxynitride.
- 26.** The memory element of claim 24, wherein the composite dielectric material includes an amorphous metal oxynitride.
- 27.** The memory element of claim 23, wherein the one or more insulator layers includes one or more  $Ta_yAl_zO_xN_w$  layers, where y, z, x, w are integer values, and where y is 1 or 2, z is 1 or 2, x is 0, 1, 3 or 5, and w is 0 or 1.
- 28.** The memory element of claim 27, wherein at least one of the one or more  $Ta_yAl_zO_xN_w$  layers has a stoichiometric structure.
- 29.** The memory element of claim 23, wherein the at least one composite dielectric material includes TaAlON.
- 30.** The memory element of claim 29, wherein the at least one composite dielectric material includes a TaAlON tunnel insulator layer.
- 31.** The memory element of claim 23, wherein the two or more electrodes are configured to form at least a portion of a flash memory circuit.
- 32.** The memory element of claim 23, wherein the one or more insulator layers includes a nanolaminate structure comprising at least one of a  $Ta_2O_5/Al_2O_3$ , a TaON/AION, a  $Ta_2O_5/AlN$ ,  $TaN/Al_2O_3$ , and a  $TaN/AlN$  structure.
- 33.** A system comprising:  
a processor;  
a memory, wherein a portion of the memory includes one or more  $Ta_yAl_zO_xN_w$  layers; and  
a data bus electrically coupled to the processor and the memory.
- 34.** The system of claim 33, wherein the memory includes at least one of a DRAM, a SRAM and a flash memory.
- 35.** The system of claim 33, wherein the  $Ta_yAl_zO_xN_w$  comprises a nanolaminate structure based on at least one of a  $Ta_2O_5/Al_2O_3$ , a TaON/AION, a  $Ta_2O_5/AlN$ , a  $TaN/Al_2O_3$ , and a  $TaN/AlN$ .
- 36.** The system of claim 33, wherein at least one of the nitrogen content and the oxygen content of the one or more  $Ta_yAl_zO_xN_w$  is less than 40%.
- 37.** A method of making an integrated circuit device comprising:  
forming a conductive layer;  
forming two or more dielectric layers, each layer comprising at least one of a refractory metal and a non-refractory metal; and  
intermixing the two or more dielectric layers to form at least a partially homogeneous dielectric layer in a region adjacent the conductive layer.
- 38.** The method of claim 37, wherein forming two or more dielectric layers includes forming at least one of a refractory metal oxide and a non-refractory metal oxide.
- 39.** The method of claim 37, wherein forming two or more dielectric layers includes forming at least one of a refractory metal nitride and a non-refractory metal nitride.
- 40.** The method of claim 37, wherein forming two or more dielectric layers includes forming at least one of a refractory metal oxynitride and a non-refractory metal oxynitride.
- 41.** The method of claim 37, wherein the forming two or more dielectric layers includes forming at least one of a  $Ta_2O_5$ , a TaN and a TaON.
- 42.** The method of claim 37, wherein the forming two or more dielectric layers includes forming at least one a  $Al_2O_3$ , a AlN and a AION.
- 43.** The method of claim 37, wherein forming two or more dielectric layers includes forming one or more  $Ta_yAl_zO_xN_w$  layers, where y, z, x, w are integer values, and where y is 1 or 2, z is 1 or 2, x is 0, 1, 3 or 5, and w is 0 or 1.
- 44.** The method of claim 37, wherein intermixing includes intermixing one or more  $Ta_yAl_zO_xN_w$  layers, where y, z, x, w are integer values, and where y is 1 or 2, z is 1 or 2, x is 0, 1, 3 or 5, and w is 0 or 1.
- 45.** The method of claim 37, wherein intermixing includes forming at least a partially homogeneous dielectric layer having greater than 20 atomic % oxygen.

**46.** The method of claim **45**, wherein the forming includes forming at least a partially homogeneous dielectric layer having less than 40 atomic % nitrogen.

**47.** The method of claim **37**, wherein intermixing includes oxidizing the at least a partially homogeneous dielectric layer.

**48.** The method of claim **37**, wherein intermixing includes nitridizing the at least a partially homogeneous dielectric layer.

**49.** The method of claim **37**, wherein intermixing includes forming the at least a partially homogeneous dielectric layer with at least one of a graded oxygen and a graded nitrogen concentration.

**50.** The method of claim **37**, wherein intermixing includes forming the at least a partially homogeneous dielectric layer with at least one of a graded tantalum and a graded aluminum concentration.

**51.** A method comprising:

propagating a voltage signal along a conductive path, at least a portion of the conductive path being adjacent to one or more insulator layers, wherein at least a portion of the one or more insulator layers comprise a mixture of a refractory metal and a non-refractory metal;

generating a charge field associated with the voltage signal across a region of the mixture between a section of the conductive path and one or more electrodes;

retaining the charge field between the section of the conductive path and the one or more electrodes based on a first specified signal; and

removing at least a portion of the charge field based on a second specified signal.

**52.** The method of claim **51**, wherein generating includes establishing a charge field across a region including one or more  $Ta_yAl_zO_xN_w$  amorphous layers, where  $y$ ,  $z$ ,  $x$ ,  $w$  are integer values, and where  $y$  is 1 or 2,  $z$  is 1 or 2,  $x$  is 0, 1, 3 or 5, and  $w$  is 0 or 1.

**53.** The method of claim **51**, wherein generating includes coupling electric charge across a region including  $Ta_yAl_zO_xN_w$ , where  $y$ ,  $z$ ,  $x$ ,  $w$  are relative mole fractions.

**54.** The method of claim **51**, wherein retaining includes transferring charge across a region including TaAlON.

**55.** The method of claim **51**, wherein generating a charge field includes inducing a charge field in a region between the one or more electrodes.

**56.** The method of claim **51**, wherein the generating includes inducing an inversion layer in the region between the one or more electrodes.

**57.** The method of claim **55**, wherein the generating includes inducing a charge depletion layer in the region between the one or more electrodes.

**58.** A method comprising:

forming alternating dielectric layers on a substrate, the layers including at least one of a refractory metal and a non-refractory metal;

surrounding the alternating layers in an environment comprising at least one of a nitrogen compound and an oxygen compound; and

forming one or more oxynitride layers using the alternating layers.

**59.** The method of claim **58**, wherein forming alternating dielectric layers includes forming alternating dielectric layers of  $TaO_xN$  and  $AlO_yN$ , where  $x$ , and  $y$  are integers with values of 0 or 1.

**60.** The method of claim **58**, wherein forming alternating dielectric layers includes forming alternating  $Ta_yAl_zO_xN_w$  layers, where  $y$ ,  $z$ ,  $x$ ,  $w$  are integer values, and where  $y$  is 1 or 2,  $z$  is 1 or 2,  $x$  is 0, 1, 3 or 5, and  $w$  is 0 or 1.

**61.** The method of claim **58**, wherein forming alternating dielectric layers includes alternating pairs of dielectric layers including at least one of a  $Ta_2O_5/Al_2O_3$ , a TaON/AlON, a  $Ta_2O_5/AlN$ , a TaN/ $Al_2O_3$ , and a TaN/AlN.

**62.** The method of claim **58**, wherein surrounding includes surrounding the alternating layers in a microwave plasma.

**63.** The method of claim **58**, wherein surrounding includes surrounding the alternating layers in an ambient comprising at least one of a dinitrogen, an ammonia, and a 1,1-dimethylhydrazine.

**64.** The method of claim **58**, wherein forming one or more oxynitride layers includes forming one or more TaAlON layers with less than 50 atomic % nitrogen.

**65.** The method of claim **64**, wherein forming one or more oxynitride layers includes forming one or more TaAlON layers with greater than 20 atomic % oxygen.

**66.** A method comprising:

generating a microwave plasma using a vapor comprising a nitrogen compound;

forming a nitride layer using an oxide layer that includes at least one of a refractory metal and a non-refractory metal; and

patterning a layer comprising at least one of refractory metal oxynitride and a non-refractory metal oxynitride.

**67.** The method of claim **66**, wherein generating includes generating a microwave plasma using vapor comprising at least one of a dinitrogen, an ammonia, and a 1,1-dimethylhydrazine.

**68.** The method of claim **66**, wherein forming includes forming a nitride layer that includes  $Ta_yAl_zO_xN_w$ , where  $y$ ,  $z$ ,  $x$ ,  $w$  are relative mole fractions.

**69.** The method of claim **68**, wherein forming includes forming  $Ta_yAl_zO_xN_w$  with at least one of  $x$ ,  $y$ ,  $z$ , and  $w$  vary in a direction substantially perpendicular to a major surface of a substrate.

**70.** The method of claim **68**, wherein forming includes forming  $Ta_xAl_{1-x-y-z}O_yN_z$ , between two or more conductive regions.

**71.** The method of claim **68**, wherein forming includes forming  $Ta_yAl_zO_xN_w$  with at least one of  $x$ ,  $y$ ,  $z$ , and  $w$  vary in a direction substantially parallel to a major surface of a substrate.

\* \* \* \* \*