



(19) **United States**  
(12) **Patent Application Publication**  
Flynn et al.

(10) **Pub. No.: US 2013/0179753 A1**  
(43) **Pub. Date: Jul. 11, 2013**

(54) **SYSTEMS AND METHODS FOR ADAPTIVE DATA STORAGE**

111, filed on Dec. 6, 2006, provisional application No. 60/974,470, filed on Sep. 22, 2007.

(71) Applicant: **Fusion-io, Inc.**, Salt Lake City, UT (US)

**Publication Classification**

(72) Inventors: **David Flynn**, Sandy, UT (US); **John Strasser**, Syracuse, UT (US); **Bill Inskip**, West Valley City, UT (US)

(51) **Int. Cl.**  
**G06F 11/10** (2006.01)

(73) Assignee: **FUSION-IO, INC.**, Salt Lake City, UT (US)

(52) **U.S. Cl.**  
CPC ..... **G06F 11/1068** (2013.01)  
USPC ..... **714/773**

(21) Appl. No.: **13/784,705**

(57) **ABSTRACT**

(22) Filed: **Mar. 4, 2013**

**Related U.S. Application Data**

(63) Continuation-in-part of application No. 13/296,834, filed on Nov. 15, 2011, which is a continuation-in-part of application No. 11/952,101, filed on Dec. 6, 2007, now Pat. No. 8,402,201.

A storage module is configured to store data segments, such as error-correcting code (ECC) codewords, within an array comprising two or more solid-state storage elements. The data segments may be arranged in a horizontal arrangement, a vertical arrangement, a hybrid channel arrangement, and/or vertical stripe arrangement within the array. The data arrangement may determine input/output performance characteristics. An optimal adaptive data storage configuration may be based on read and/or write patterns of storage clients, read time, stream time, and so on. Data of failed storage elements may be reconstructed by use of parity data and/or other ECC codewords stored within the array.

(60) Provisional application No. 61/606,253, filed on Mar. 2, 2012, provisional application No. 61/606,755, filed on Mar. 5, 2012, provisional application No. 60/873,

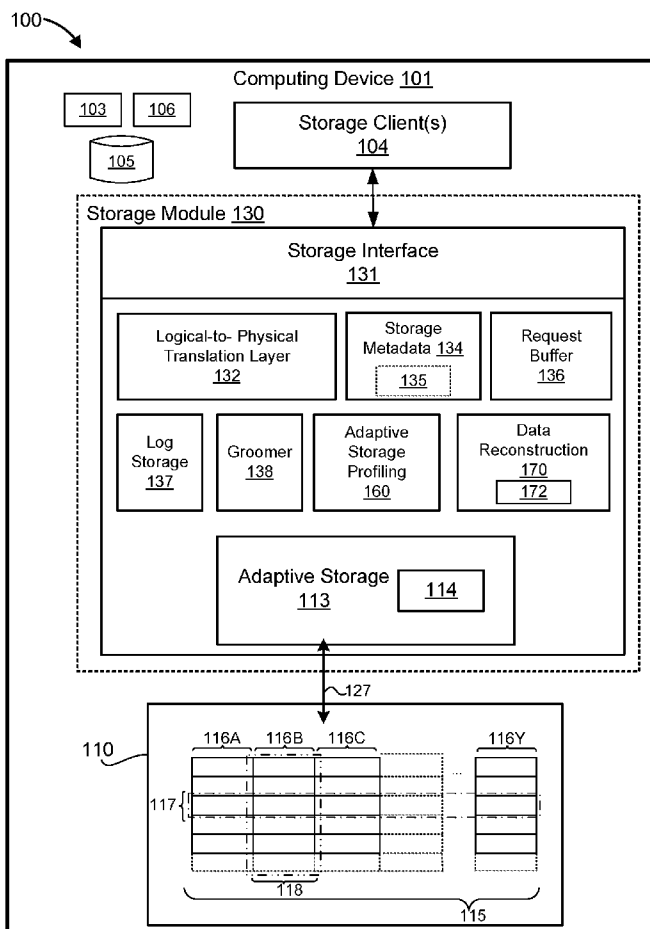

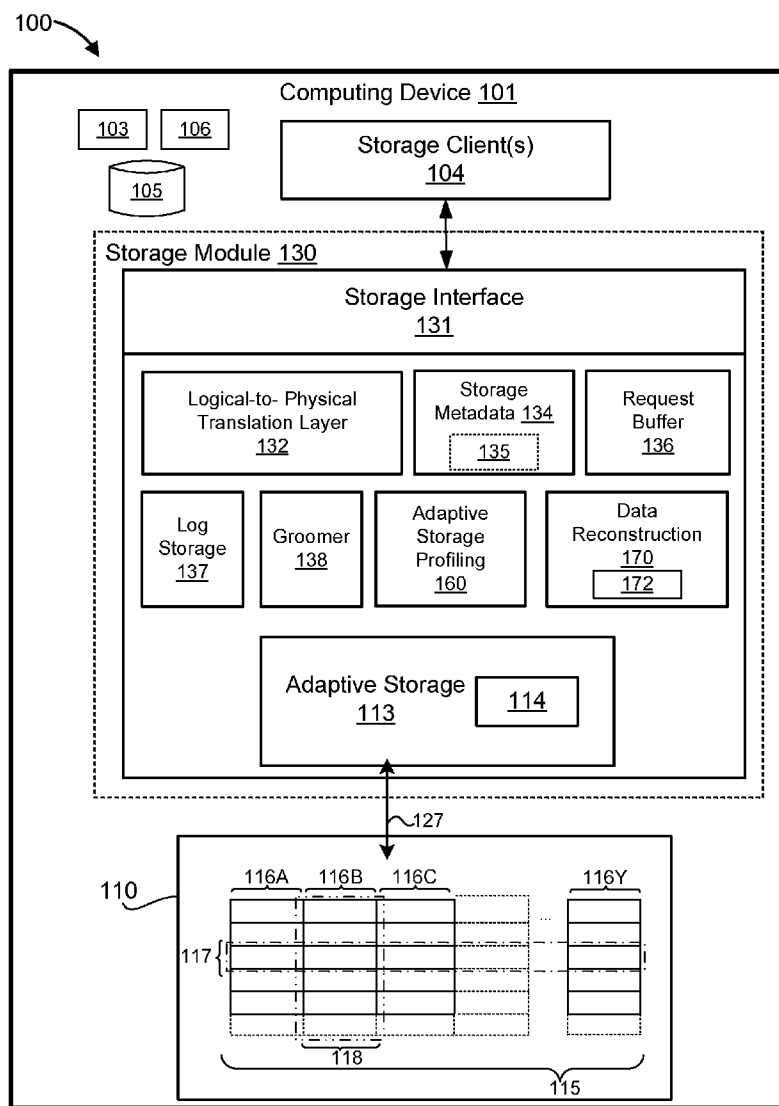

FIG. 1

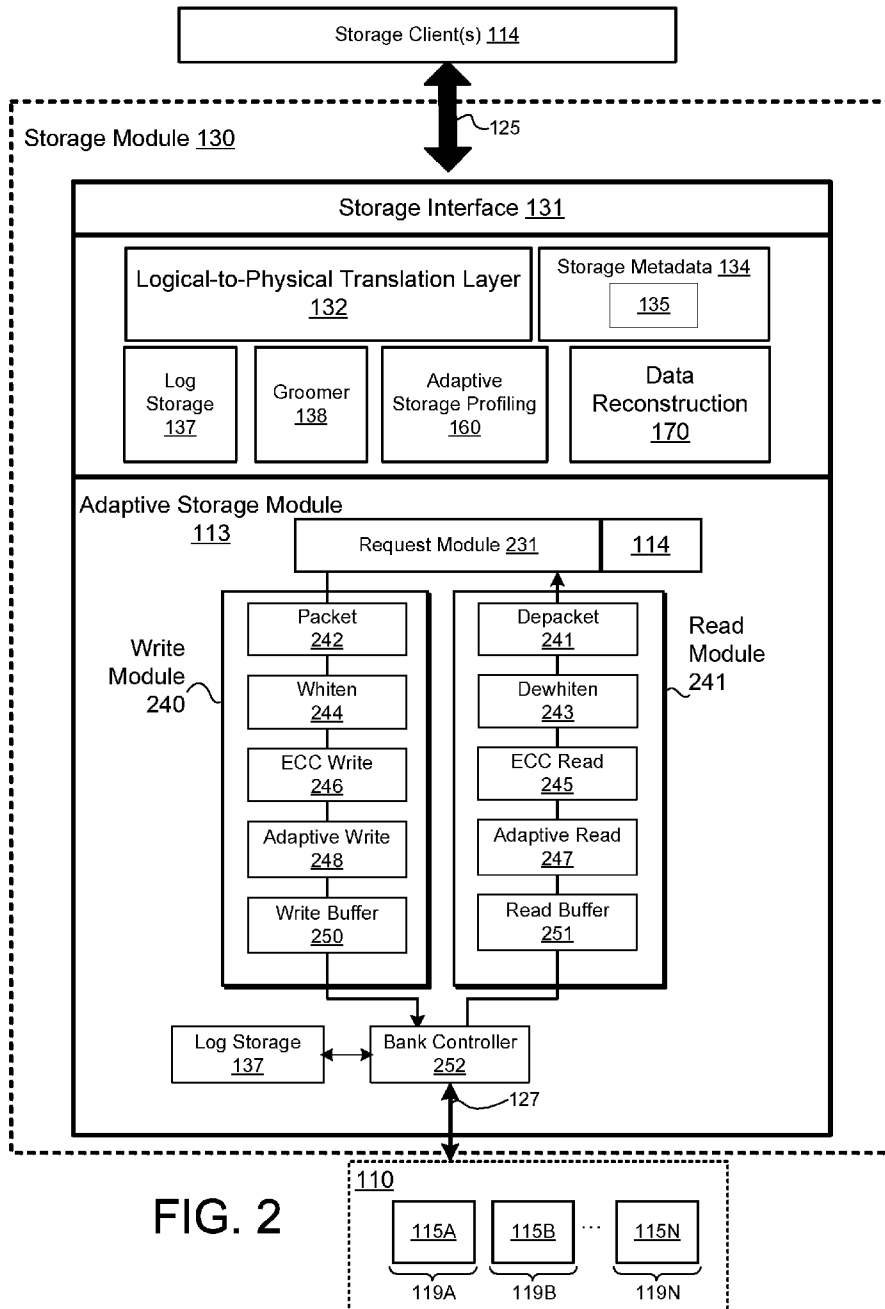

FIG. 2

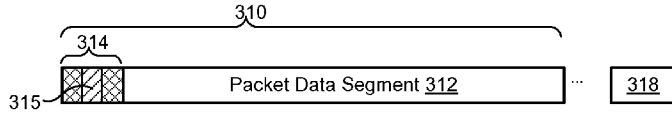

FIG. 3

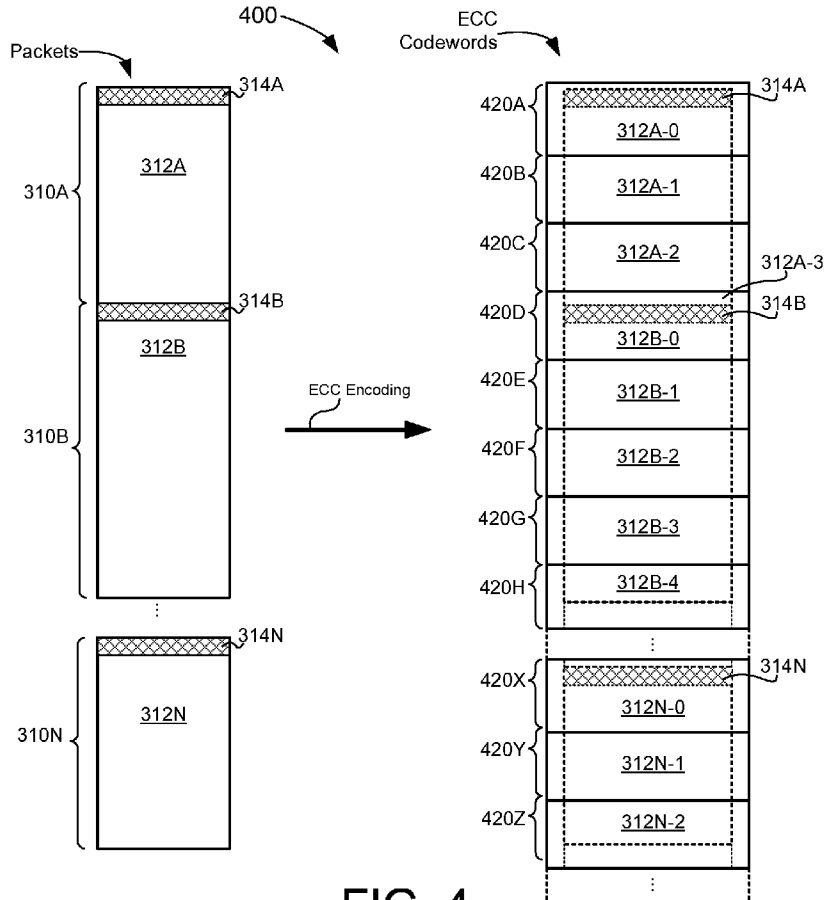

FIG. 4

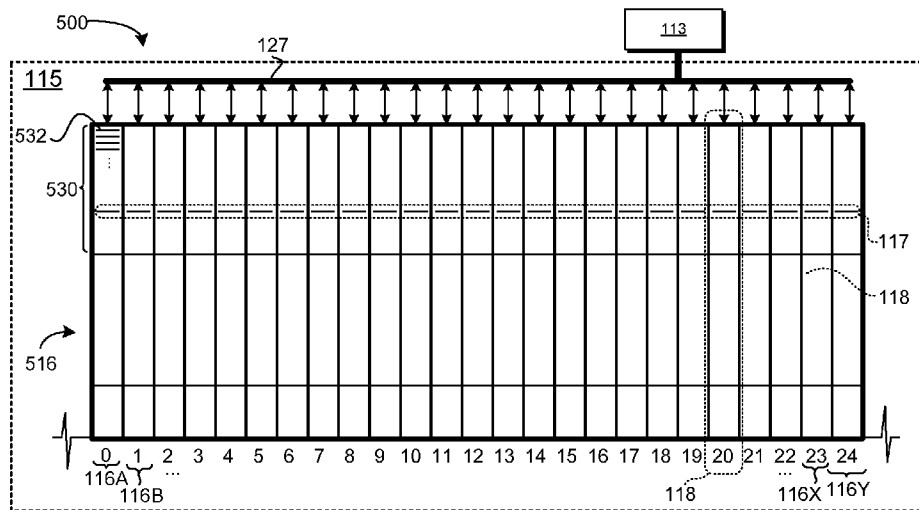

FIG. 5A

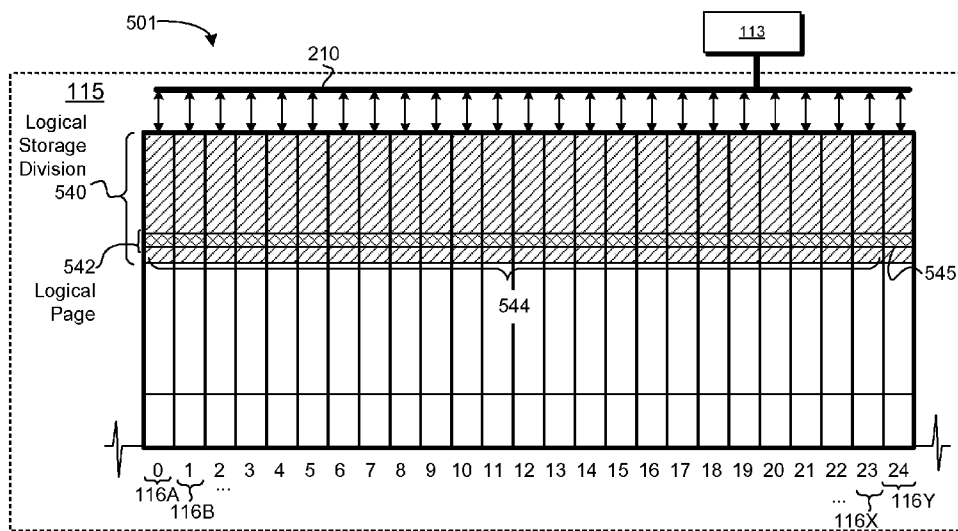

FIG. 5B

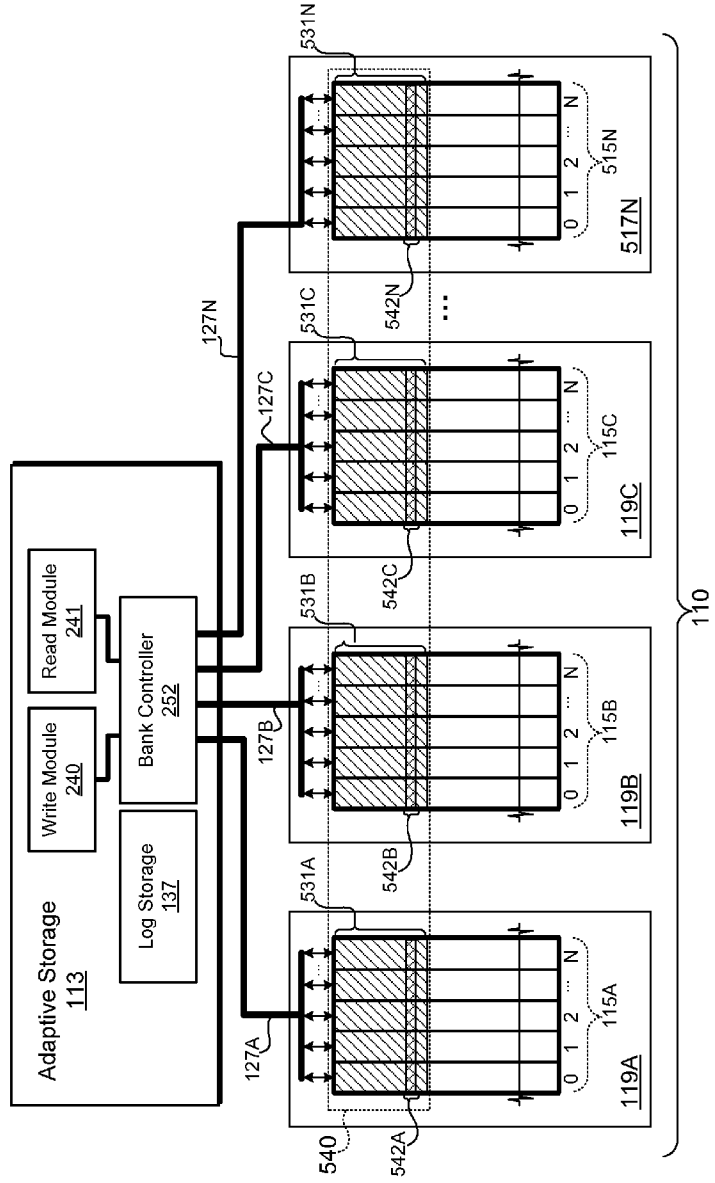

FIG. 5C

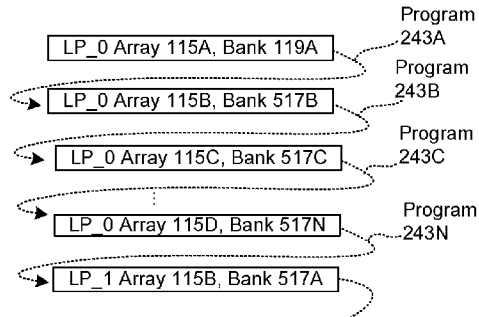

FIG. 5D

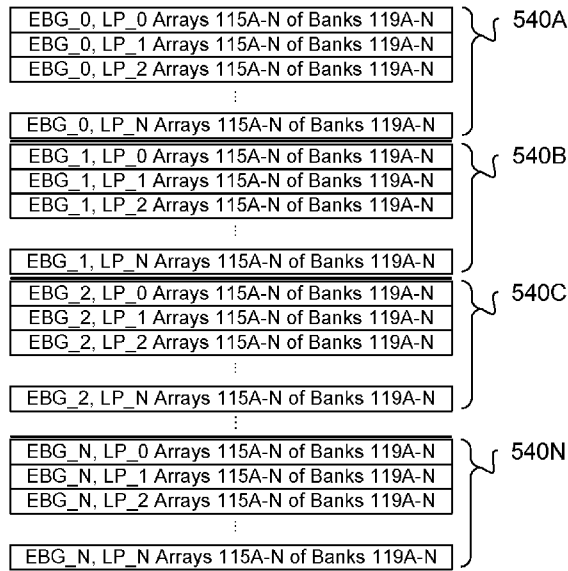

FIG. 5E

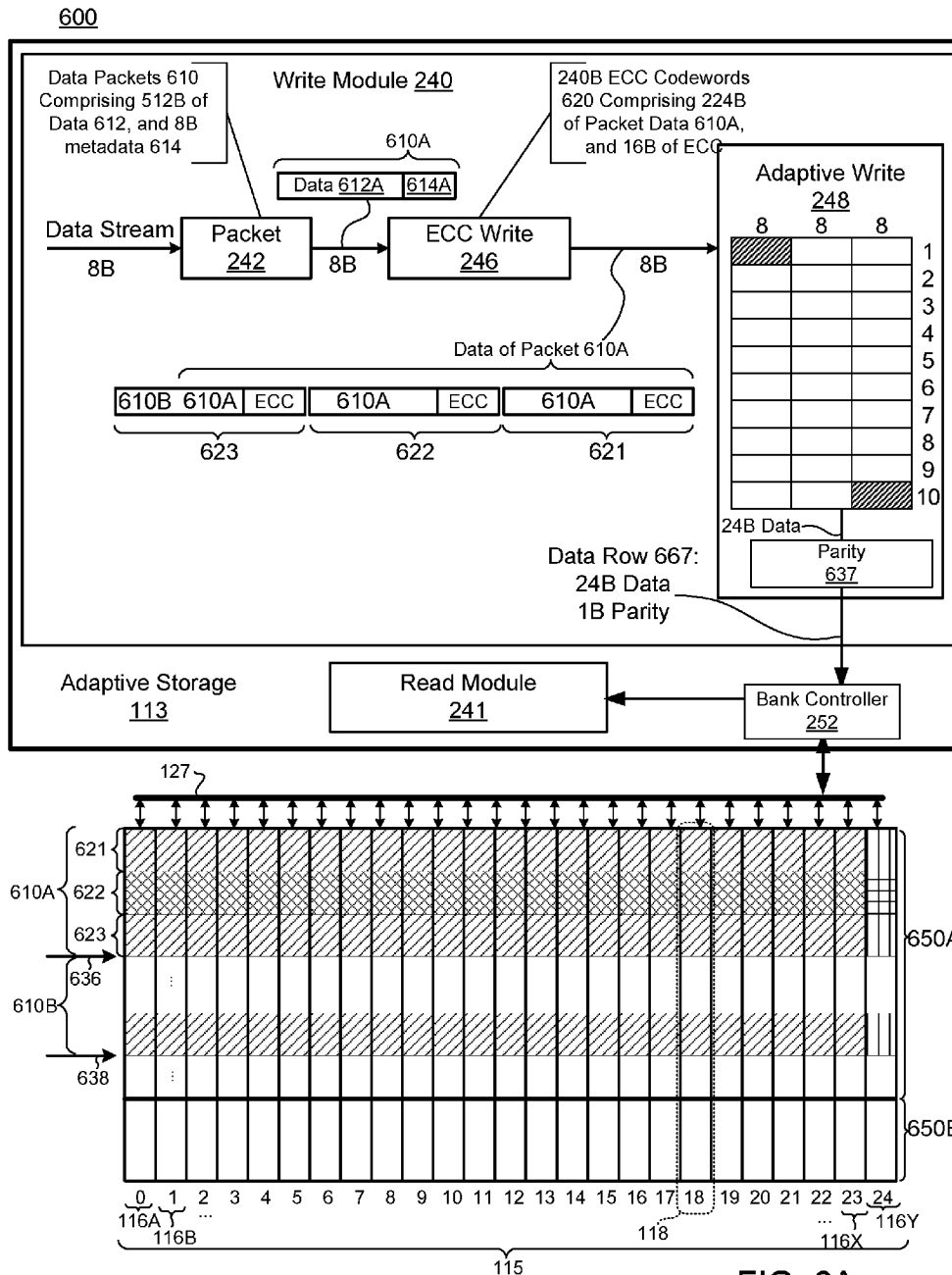

FIG. 6A

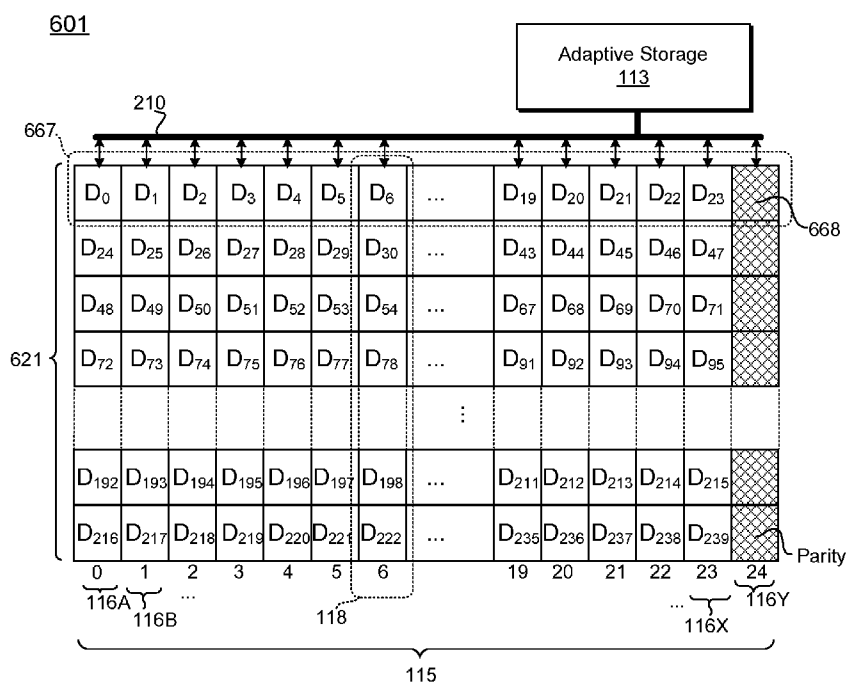

FIG. 6B

602

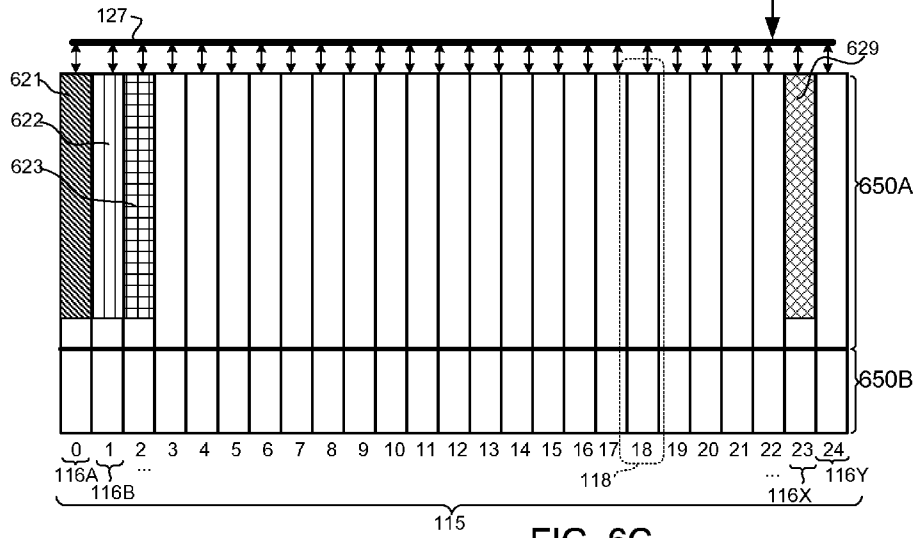
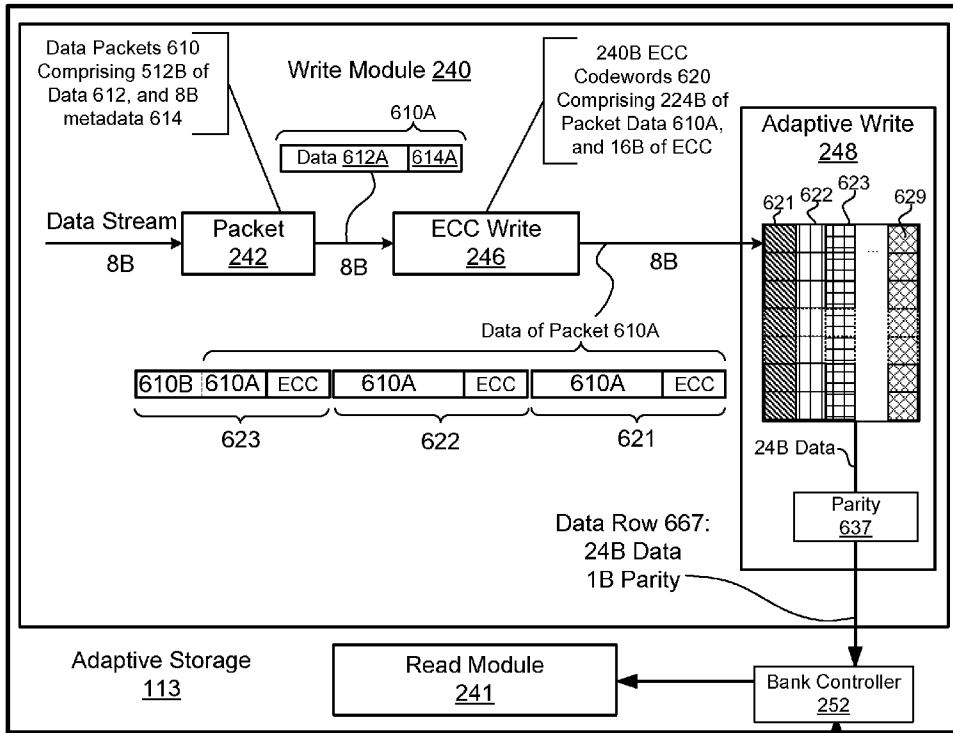

FIG. 6C

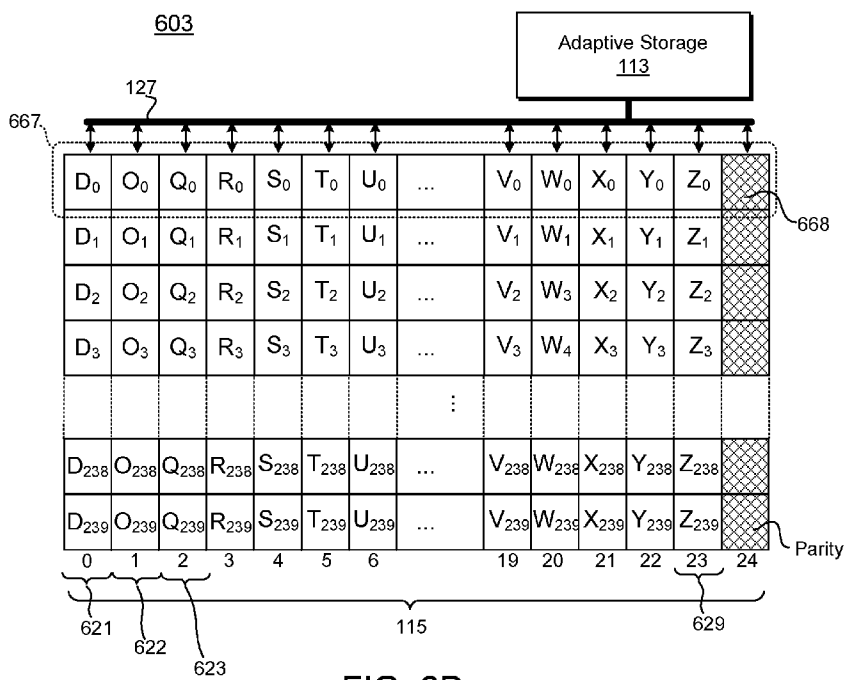

FIG. 6D

604

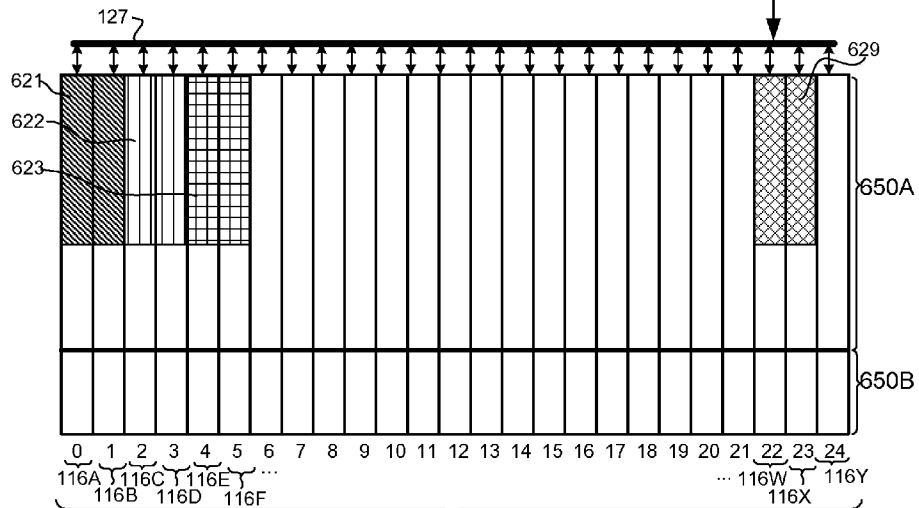
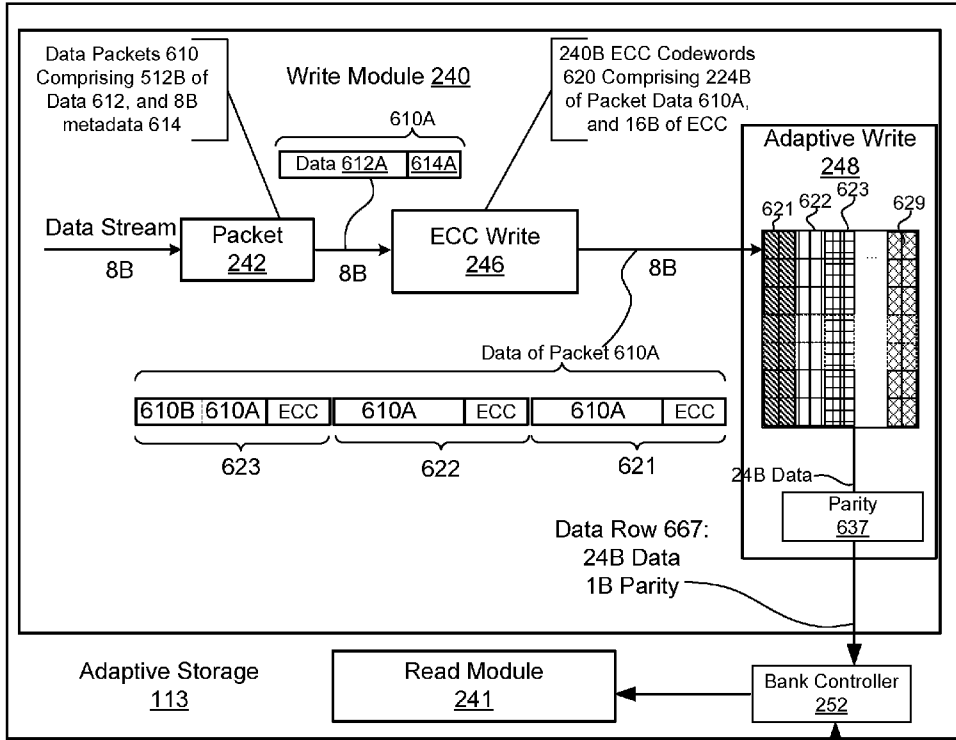

FIG. 6E

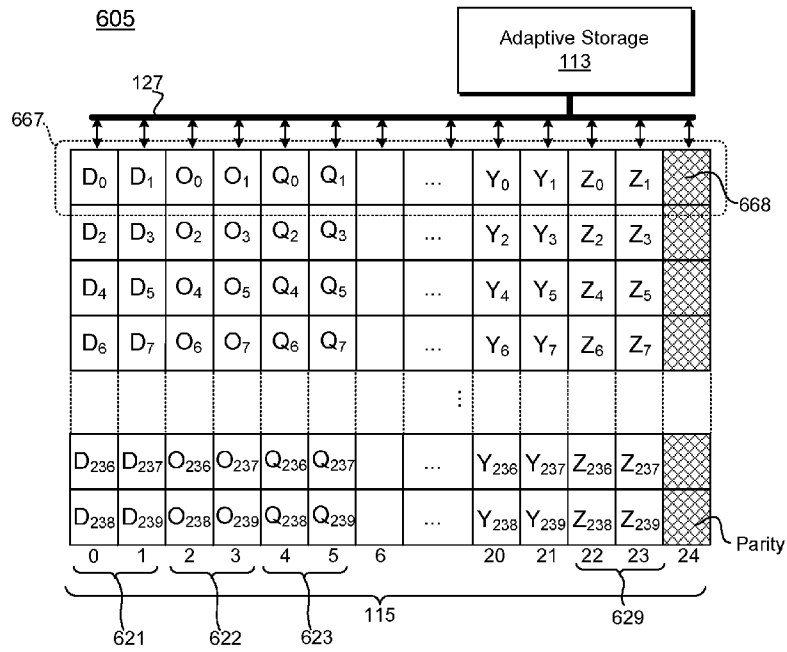
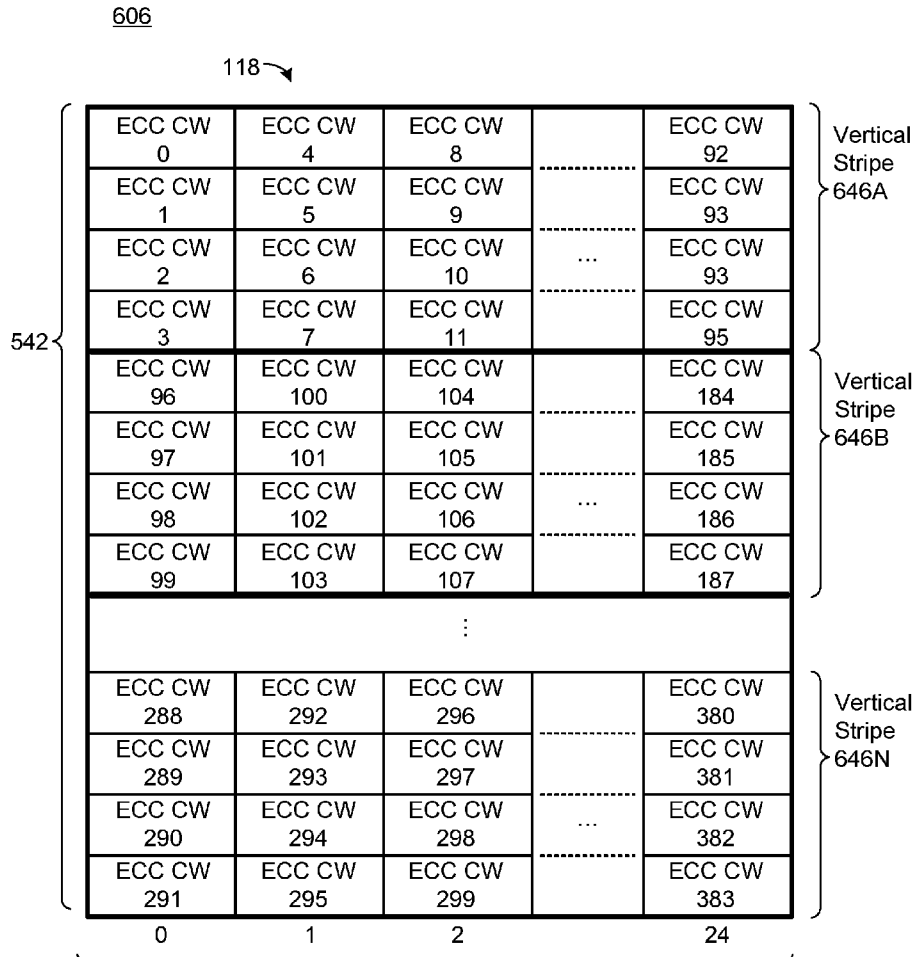

FIG. 6F



115 FIG. 6G

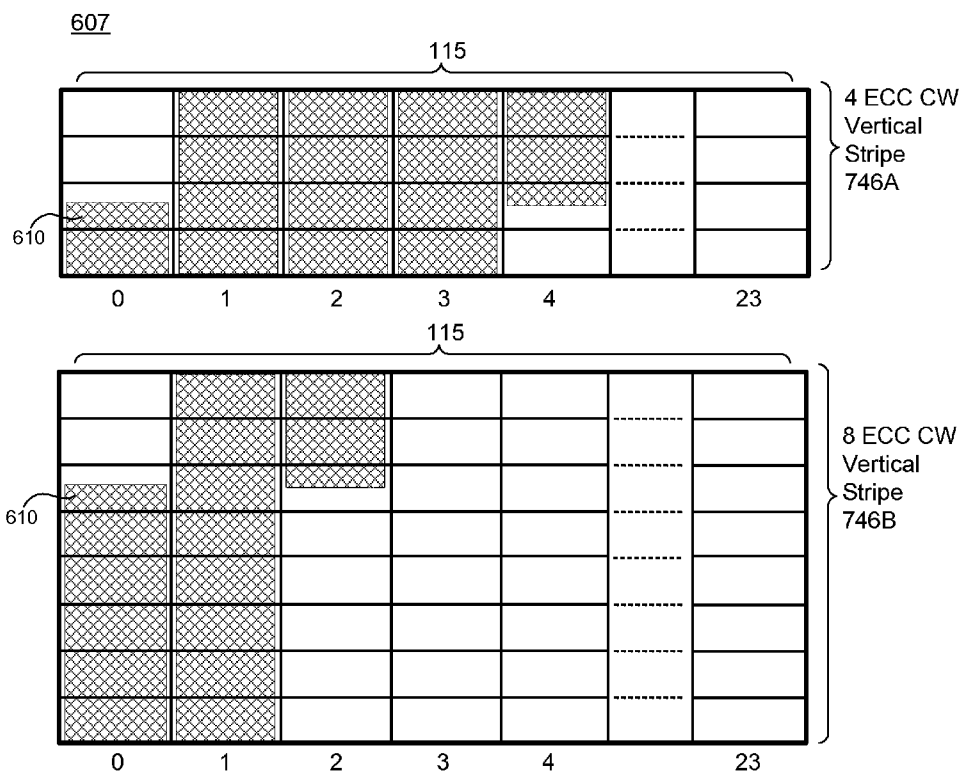
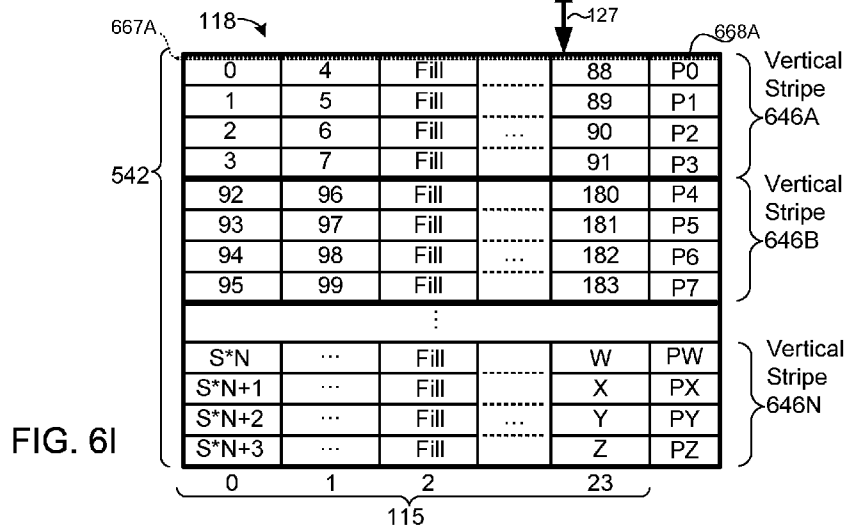
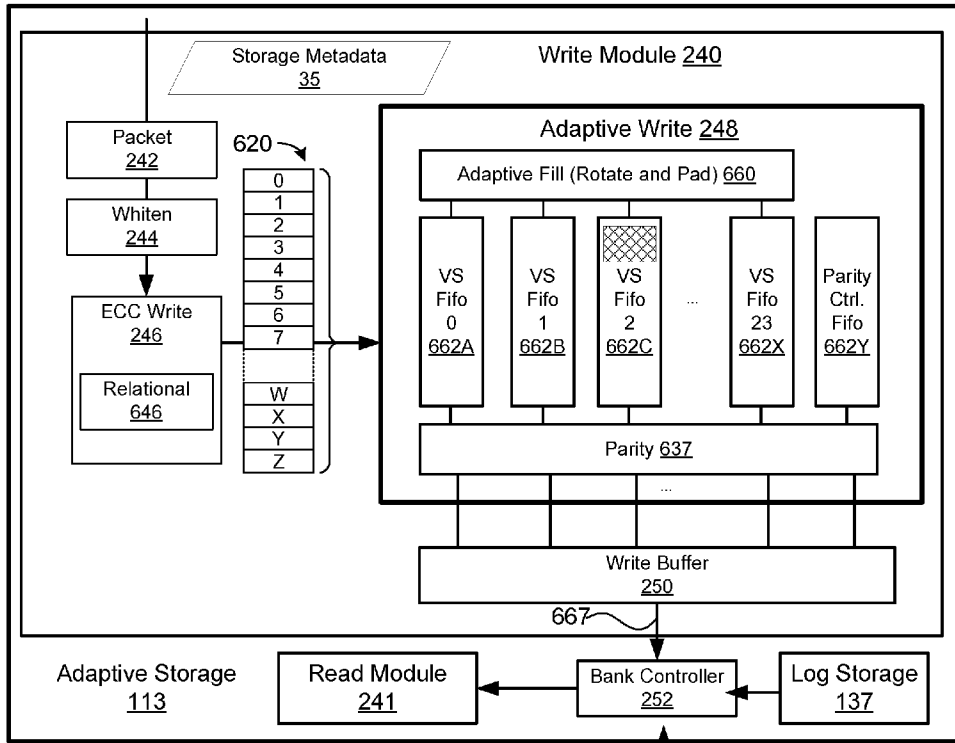

FIG. 6H

608



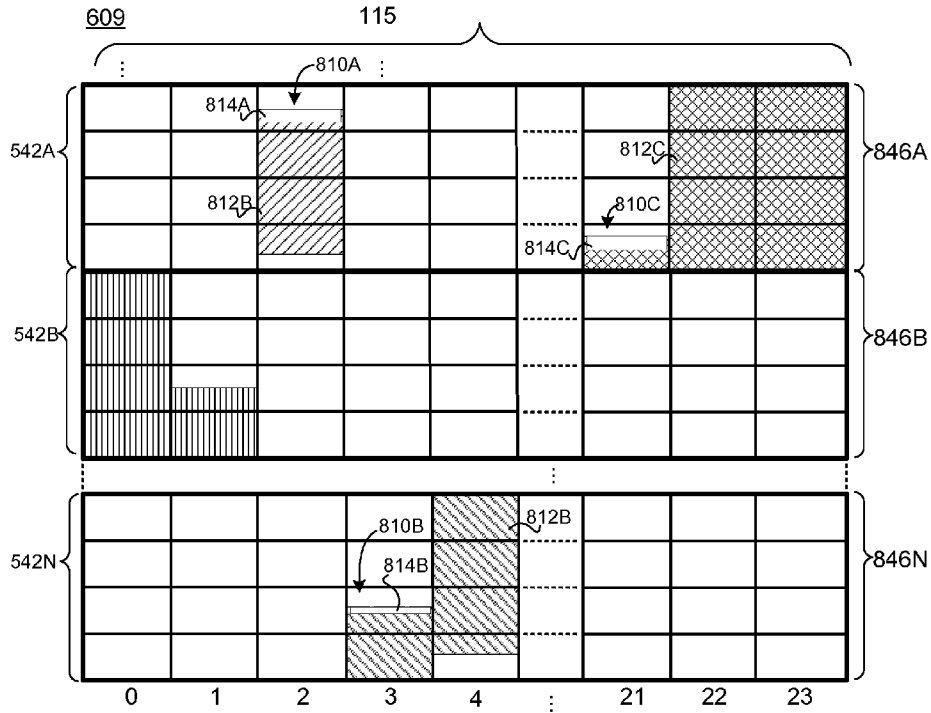

FIG. 6J

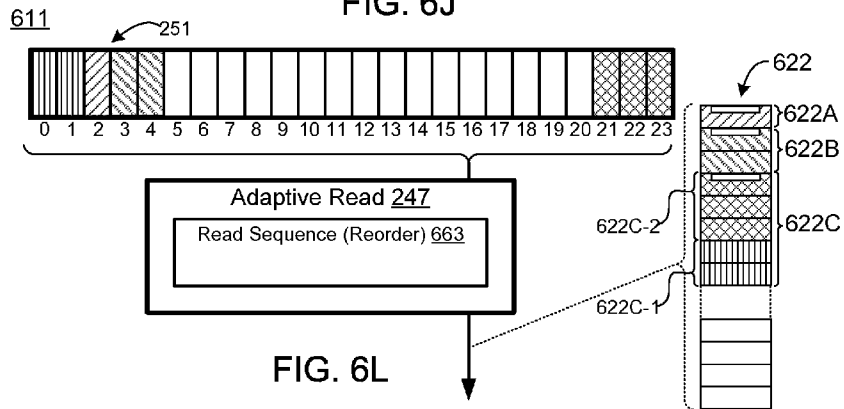
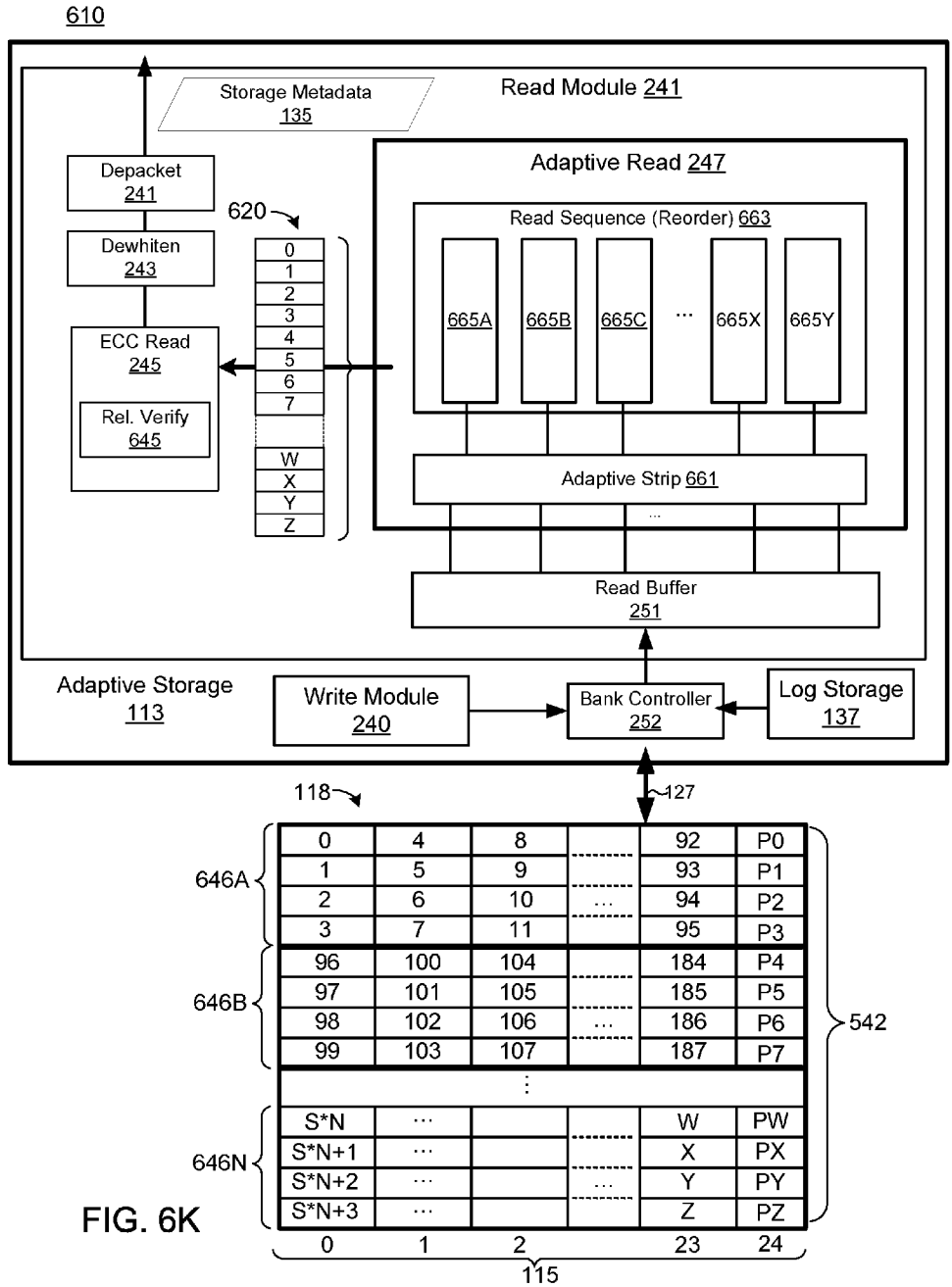

FIG. 6L



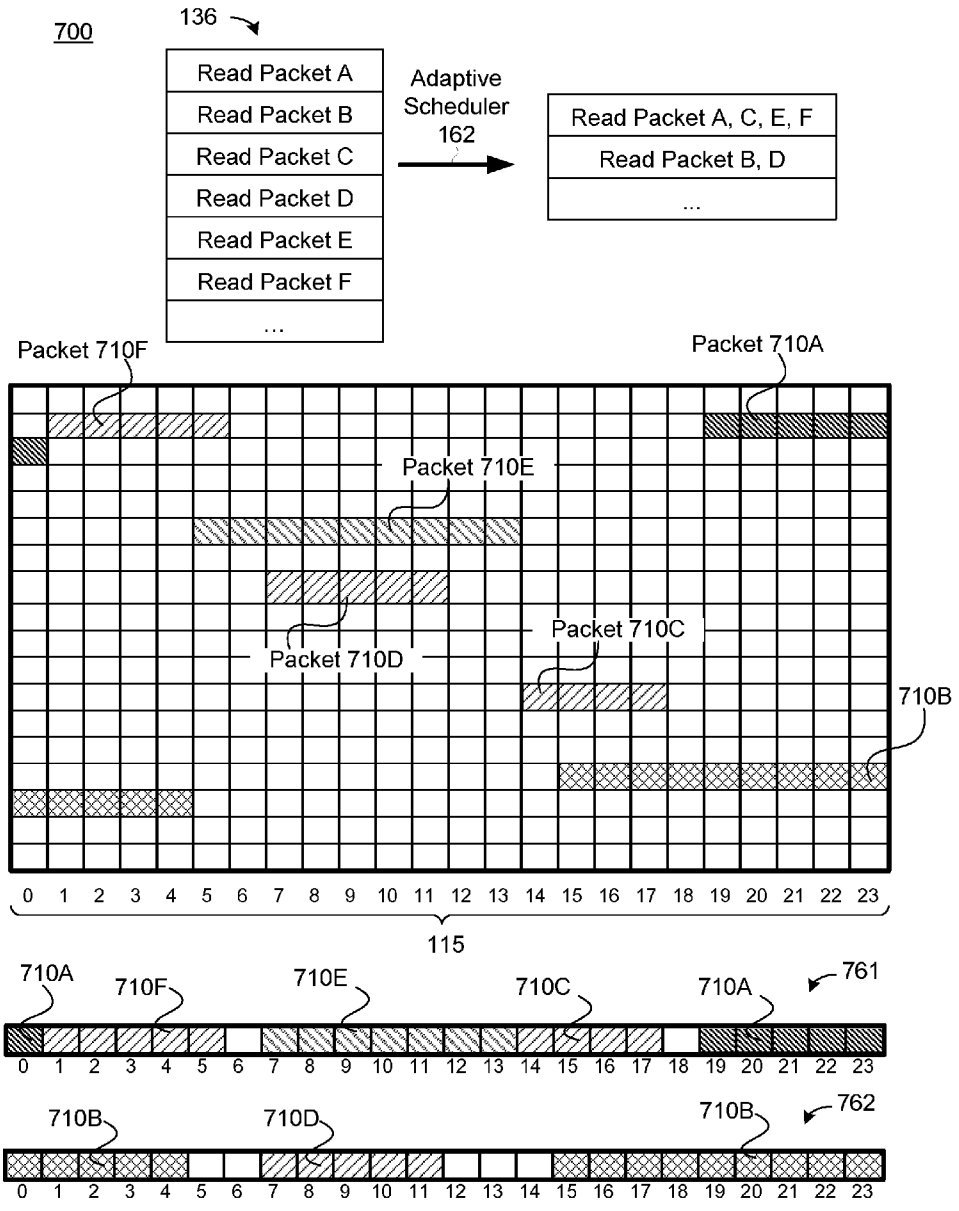

FIG. 7

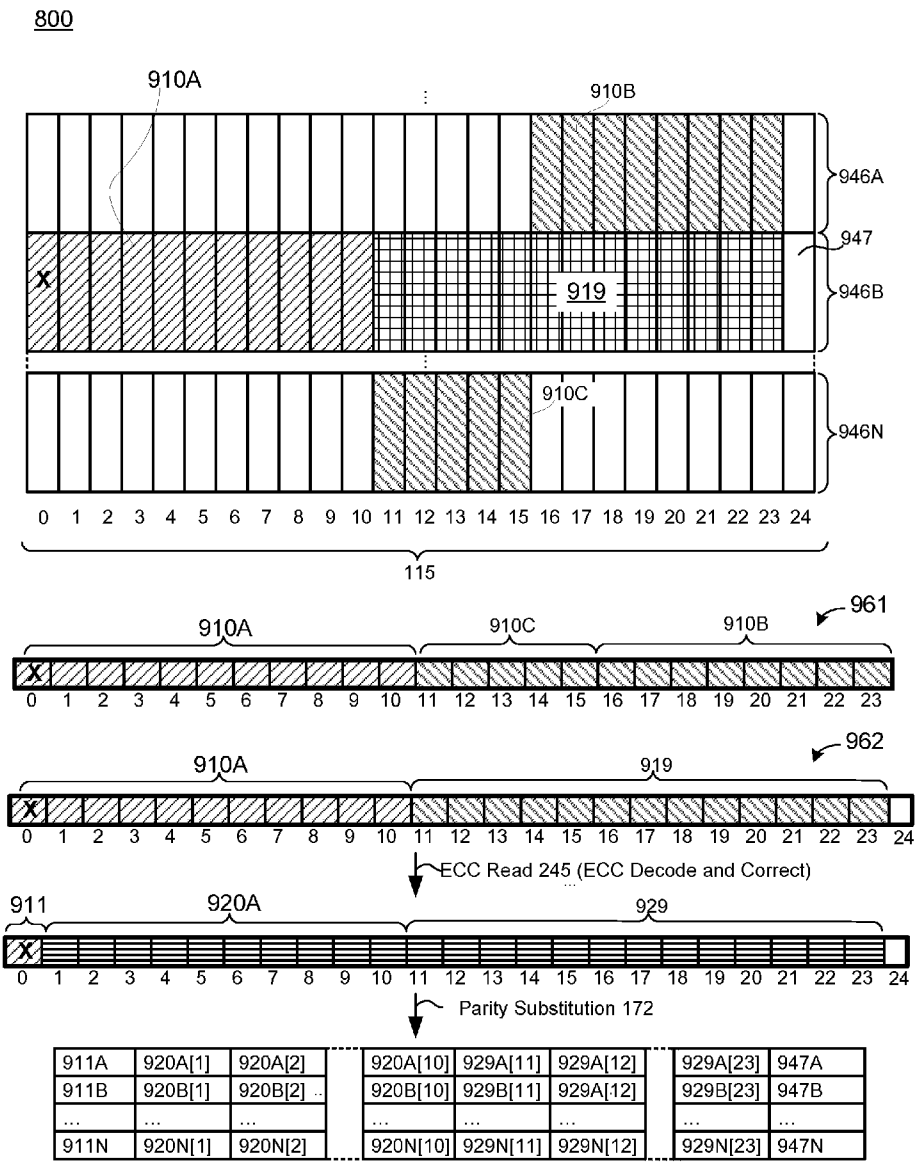

FIG. 8

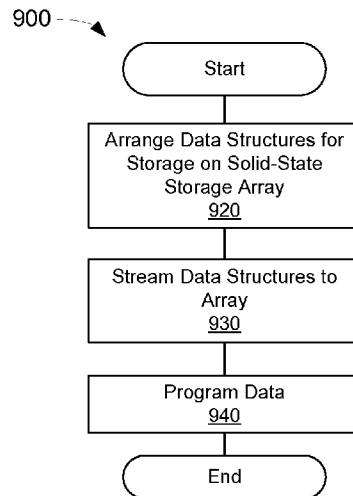

FIG. 9

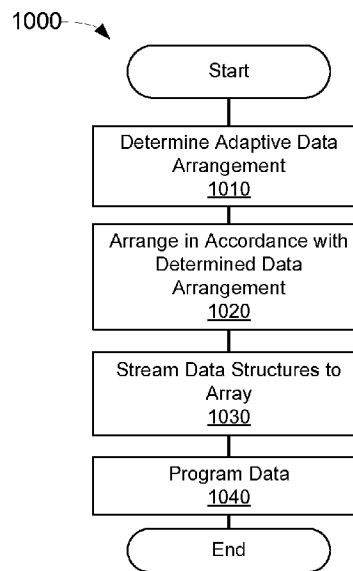

FIG. 10

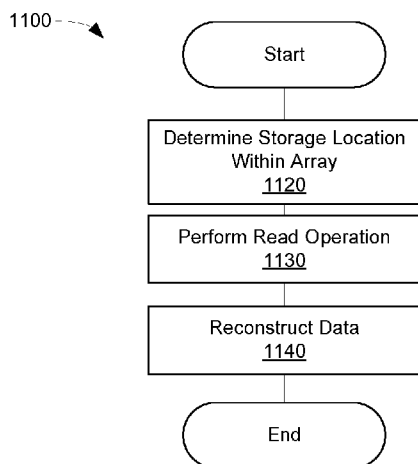

FIG. 11

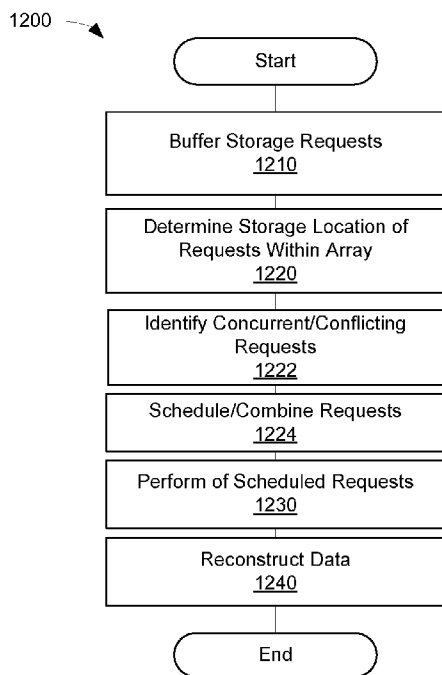

FIG. 12

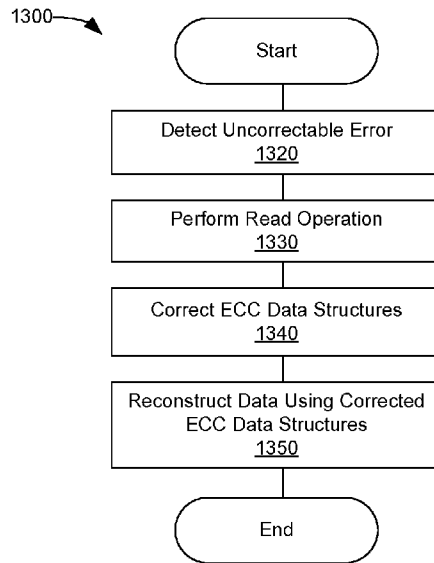

FIG. 13

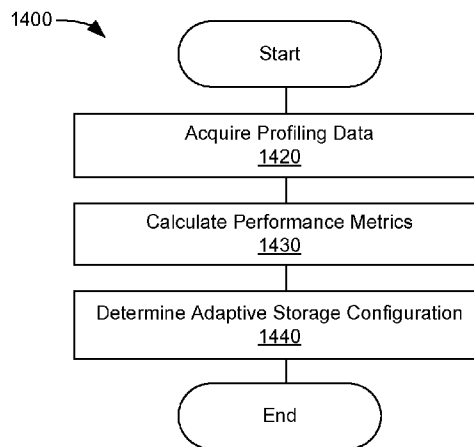

FIG. 14

## SYSTEMS AND METHODS FOR ADAPTIVE DATA STORAGE

### CROSS-REFERENCE TO RELATED APPLICATIONS

**[0001]** This application claims priority to U.S. Provisional Patent Application Ser. No. 61/606,253, entitled, "Adaptive Data Arrangement," filed Mar. 2, 2012 for David Flynn et al. and to U.S. Provisional Patent Application Ser. No. 61/606,755, entitled, "Adaptive Data Arrangement," filed Mar. 5, 2012, for David Flynn et al., and is a continuation-in-part of, and claims priority to, U.S. patent application Ser. No. 13/296,834, entitled, "Apparatus, System, and Method for Storage Space Recovery in Solid-State Storage," filed Nov. 15, 2011, for David Flynn et al., which is a continuation-in-part of, and claims priority to, U.S. patent application Ser. No. 11/952,101 entitled "Apparatus, System, and Method for Storage Space Recovery in Solid-State Storage," filed on Dec. 6, 2007 for David Flynn, et al., which claims priority to U.S. Provisional Patent Application Ser. No. 60/873,111 entitled "Elemental Blade System" filed on Dec. 6, 2006 for David Flynn, et al., and to U.S. Provisional Patent Application Ser. No. 60/974,470 entitled "Apparatus, System, and Method for Object-Oriented Solid-State Storage" filed on Sep. 22, 2007 for David Flynn, et al., each of which are incorporated herein by reference.

### TECHNICAL FIELD

**[0002]** This disclosure relates to data storage and, in particular, to data layout and/or arrangement on a solid-state storage medium.

### BACKGROUND

**[0003]** Solid-state storage devices may have different read time  $T_r$ , stream time  $T_s$ , and other characteristics, which may affect device performance in different data layout configurations. Usage characteristics, such as the size of typical read and/or write operations may also impact device performance. What is needed is a storage module capable of adaptive data layout to enable the solid-state storage device to provide improved performance in accordance with different storage medium characteristics and/or device usage patterns.

### SUMMARY

**[0004]** Disclosed herein are embodiments of an apparatus for adaptive data storage. The apparatus may comprise a storage module configured to manage storage operations on a plurality of solid-state storage elements, an error-correcting code (ECC) write module configured to generate an ECC codeword comprising data for storage on the solid-state storage elements, and an adaptive write module configured to store portions of the ECC codeword on two or more of the solid-state storage elements. The ECC write module may be configured to generate a first set of ECC codewords comprising data of a first storage request and a second set of ECC codewords comprising data of a second storage request. The adaptive write module may be configured to store the first set of ECC codewords in a first set of one or more solid-state storage elements and to store the second set of ECC codewords in a second, different set of one or more solid-state storage elements.

**[0005]** The apparatus may further comprise an adaptive read module configured to read ECC codewords comprising

the data of the first storage request from the first set of solid-state storage elements and to read ECC codewords comprising the data of the second storage request from the second set of solid-state storage elements in a single read operation.

**[0006]** In some embodiments, the adaptive write module may be configured to divide the plurality of solid-state storage elements into a plurality of independent channels, each independent channel comprising a respective subset of solid-state storage elements. The adaptive write module may be configured to store ECC codewords corresponding to respective storage requests within respective independent channels.

**[0007]** The apparatus may comprise an adaptive profiling module configured to determine an optimal independent channel configuration based on one or more of a read time of the solid-state storage elements, a stream time of ECC codewords, and/or profiling data pertaining to storage operations performed by the storage module.

**[0008]** In some embodiments, the apparatus further comprises a relational module configured to mark the ECC codeword with relational information derived from a logical identifier corresponding to the data of the ECC codeword, and an ECC decode module configured to validate the mark.

**[0009]** Disclosed here are embodiments of an apparatus for adaptive storage comprising, a storage module configured to manage storage operations on a solid-state storage array comprising a plurality of columns, each column comprising a respective solid-state storage element, an ECC write module configured to generate ECC codewords comprising data segments for storage on the solid-state storage array, and an adaptive write module configured to format the ECC codewords into vertical stripes, wherein the vertical stripes are configured to arrange data of the ECC codewords within respective columns of the solid-state storage array, wherein two or more ECC codewords comprising one of the data segments are stored within two or more different columns.

**[0010]** The apparatus may further comprise an adaptive read module configured to identify two or more columns comprising ECC codewords comprising a requested data segment, and to read the ECC codewords comprising the requested data segment from the two or more columns in parallel.

**[0011]** In some embodiments, the apparatus further comprises a read sequence module configured to reorder the ECC codewords in accordance with an order of the requested data segment and the vertical stripe arrangement of the ECC codewords within the solid-state storage array. The apparatus may also include an adaptive schedule module configured to combine two or more read operations into a combined read operation, the two or more read operations corresponding to ECC codewords stored within different sets of columns of the solid-state storage array. The apparatus may include an ordered queue of storage requests, wherein the adaptive schedule module is configured to combine two or more read operations within the ordered queue into the combined read operation, wherein combining the two or more storage requests comprises modifying an order of the storage requests within the ordered queue. The combined read operation may comprise providing different addressing information to the different sets of columns of the solid-state storage array.

**[0012]** The apparatus may further include an ECC read module configured to detect an uncorrectable ECC codeword in response to a first read operation, and a data recovery module configured to recover the uncorrectable ECC codeword by reading other ECC codewords within the vertical

stripe with the uncorrectable ECC codeword in a second read operation, decoding the other ECC codewords, and reconstructing the uncorrectable ECC codeword using the decoded ECC codewords and parity data of the vertical stripe.

**[0013]** Disclosed herein are embodiments of an apparatus, comprising a write module configured to generate data rows for storage within columns of a solid-state storage array, a parity module configured to generate respective parity data for each of the data rows, and an adaptive write module configured to stream the data rows and the corresponding parity data to respective columns of the solid-state storage array in parallel.

**[0014]** The apparatus may include an adaptive write module configured to arrange ECC codewords for storage within respective subsets of the columns of the solid-state storage array, wherein each of the data rows comprises data of two or more different ECC codewords. The adaptive write module may be configured to store the two or more different ECC codewords within respective subsets of columns of the solid-state storage array by streaming a plurality of data rows and corresponding parity data to the respective columns of the solid-state storage array, wherein each data row comprises data of each of the two or more different ECC codewords. In some embodiments, each data row comprises a byte of each of the two or more different ECC codewords and a corresponding parity byte.

**[0015]** The apparatus may further comprise a data reconstruction module configured to reconstruct an uncorrectable ECC codeword of the two or more ECC codewords by accessing data rows and corresponding parity data comprising the two or more ECC codewords from the solid-state storage array, correcting other ECC codewords within the accessed data rows, and reconstructing the uncorrectable ECC codeword using the corrected ECC codewords and the corresponding parity data. Reconstructing the uncorrectable ECC codeword may comprise a byte-wise parity substitution using the corrected ECC codewords and the corresponding parity data.

**[0016]** Disclosed herein are embodiments of a method for adaptive storage. The disclosed methods may comprise one or more machine-executable operations and/or steps. The disclosed operations and/or steps may be embodied as program code stored on a computer readable storage medium. Accordingly, embodiments of the methods disclosed herein may be embodied as a computer program product comprising a computer readable storage medium storing computer usable program code executable to perform one or more method operations and/or steps.

**[0017]** The disclosed method may comprise acquiring profiling data pertaining to storage operations performed on a solid-state storage array comprising a plurality of independent data columns, each independent data column comprising a solid-state storage element, determining performance characteristics corresponding to a plurality of different adaptive data storage configurations, wherein each of the adaptive data storage configurations corresponds to storage of data segments in one of a horizontal configuration, a vertical configuration, a hybrid configuration, and a vertical stripe configuration, and determining an optimal adaptive data storage configuration based on the determined performance characteristics. The horizontal configuration may comprise storing ECC codewords within each of the independent data columns. The vertical configuration may comprise storing ECC codewords within respective independent data columns. The

hybrid configuration may comprise storing ECC codewords within respective subsets of the independent data columns. The vertical stripe configuration may comprise storing ECC codewords within respective independent data columns at a vertical stripe depth. The vertical stripe depth may be less than a page depth of the solid-state storage elements.

**[0018]** Disclosed herein is a method for adaptive storage comprising identifying an uncorrectable ECC codeword stored within one of a plurality of solid-state storage elements, correcting one or more ECC codewords stored within others of the plurality of solid-state storage elements, accessing parity data corresponding to the uncorrectable ECC codeword and corrected ECC codewords, and rebuilding data of the uncorrectable ECC codeword through parity substitution operations comprising the corrected ECC codewords and the accessed parity data. The method may further comprise arranging ECC codewords for storage within respective independent channels, each independent channel comprising one or more of the solid-state storage elements.

**[0019]** In some embodiments, the method includes buffering ECC codewords for storage within respective solid-state storage elements, and streaming data rows to the solid-state storage elements, each data row comprising a byte of a respective ECC codeword for storage on a respective one of the solid-state storage elements and a corresponding parity byte. Rebuilding data of the uncorrectable ECC codeword may comprise accessing data rows stored within the solid-state storage elements and performing byte-wise parity substitution operations to rebuild the uncorrectable ECC codeword.

**[0020]** Disclosed herein are methods for adaptive storage comprising, determining a storage location of a plurality of ECC codewords comprising requested data, wherein the ECC codewords are stored within a group of two or more different solid-state storage elements of a solid-state storage array, identifying ECC codewords comprising data of one or more other requests stored within different groups of solid-state storage elements of the solid-state storage array, scheduling a read operation on the solid-state storage array configured to read the ECC codewords of the requested data and ECC codewords comprising data of the one or more other requests in a single read operation on the solid-state storage array.

**[0021]** The method may further include queuing storage requests in an ordered request buffer, and determining a storage location of ECC codewords of one or more other requests in the request buffer. Scheduling the read operation may comprise reordering one or more storage requests in the ordered request buffer. Scheduling the read operation may further include providing different addressing information for two or more of the solid-state storage elements. In some embodiments, the method further comprises reordering contents of a read buffer to reconstruct a data packet stored within the plurality of ECC codewords comprising the requested data.

**[0022]** Disclosed herein are embodiments of a system for adaptive storage, comprising means for generating ECC codewords comprising data segments for storage on one or more solid-state storage elements, wherein each solid-state storage element is communicatively coupled to a storage controller by a bus, means for arranging the ECC codewords for storage in a vertical stripe configuration, wherein the vertical stripe configuration comprises arranging each ECC codeword for storage within a respective one of the solid-state storage elements, and wherein ECC codewords comprising a

data segment are arranged for storage on two or more different solid-state storage elements, and means for storing the arranged ECC codewords on the solid-state storage elements. The vertical stripe configuration may comprise arranging ECC codewords within the solid-state storage elements at a vertical stripe depth, wherein the vertical stripe depth is less than a page size of the solid-state storage elements and is an integral factor of a size of the ECC codewords.

**[0023]** In some embodiments, the means for arranging the ECC codewords for storage in the vertical stripe configuration comprises means for streaming data rows of the arranged ECC codewords to respective program buffers of the solid-state storage array and means for calculating parity data corresponding to each of the data rows.

**[0024]** The system may further include means for reconstructing a corrupt ECC codeword, comprising

**[0025]** means for reading one or more other ECC codewords stored within a vertical stripe comprising the corrupt ECC codeword, means for correcting the one or more other ECC codewords, and means for reconstructing the corrupt ECC codeword using the corrected one or more other ECC codewords and parity data corresponding to data rows of the vertical stripe.

**[0026]** In some embodiments, the system may further comprise means for adaptive scheduling, including means for identifying respective sets of one or more solid-state storage elements comprising data of each of a plurality of queued read requests, and means for determining a read operation configured to perform two or more of the queued read requests in a single read operation on the plurality of solid-state storage elements.

#### BRIEF DESCRIPTION OF THE DRAWINGS

**[0027]** FIG. 1 is a block diagram of one embodiment of a system for adaptive storage;

**[0028]** FIG. 2 is a block diagram of one embodiment of a storage module;

**[0029]** FIG. 3 depicts one embodiment of a packet;

**[0030]** FIG. 4 depicts one embodiment of ECC codewords comprising one or more data segments;

**[0031]** FIG. 5A is a block diagram depicting one embodiment of a solid-state storage array;

**[0032]** FIG. 5B is a block diagram depicting another embodiment of a solid-state storage array;

**[0033]** FIG. 5C is a block diagram depicting another embodiment of banks of solid-state storage arrays;

**[0034]** FIG. 5D depicts one embodiment of sequential bank interleave;

**[0035]** FIG. 5E depicts another embodiment of sequential bank interleave;

**[0036]** FIG. 6A is a block diagram of one embodiment of a system for adaptive data storage;

**[0037]** FIG. 6B depicts one embodiment of horizontal, adaptive data storage;

**[0038]** FIG. 6C is a block diagram of another embodiment of a system for adaptive data storage;

**[0039]** FIG. 6D depicts one embodiment of vertical, adaptive data storage;

**[0040]** FIG. 6E is a block diagram of another embodiment of a system for adaptive data storage;

**[0041]** FIG. 6F depicts another embodiment of adaptive data storage on a solid-state storage array;

**[0042]** FIG. 6G depicts one embodiment of a vertical stripe configuration on a solid-state storage array;

**[0043]** FIG. 6H depicts another embodiment of a vertical stripe configuration on a solid-state storage array;

**[0044]** FIG. 6I is a block diagram of another embodiment of a system for adaptive data storage;

**[0045]** FIG. 6J depicts another embodiment of a vertical stripe configuration on a solid-state storage array;

**[0046]** FIG. 6K is a block diagram of another embodiment of a system for adaptive data storage;

**[0047]** FIG. 6L is a block diagram of another embodiment of a system for adaptive data storage;

**[0048]** FIG. 7 depicts one embodiment of a system for adaptive scheduling;

**[0049]** FIG. 8 depicts one embodiment of a system for adaptive data reconstruction;

**[0050]** FIG. 9 is a flow diagram of one embodiment of a method for adaptive storage on a solid-state storage array;

**[0051]** FIG. 10 is a flow diagram of another embodiment of a method for adaptive storage on a solid-state storage array;

**[0052]** FIG. 11 is a flow diagram of another embodiment of a method for adaptive storage on a solid-state storage array;

**[0053]** FIG. 12 is a flow diagram of one embodiment of a method for adaptive scheduling of storage requests;

**[0054]** FIG. 13 is a flow diagram of one embodiment of a method for adaptive data recovery; and

**[0055]** FIG. 14 is a flow diagram of one embodiment of a method for determining an adaptive data storage configuration.

#### DETAILED DESCRIPTION

**[0056]** FIG. 1 is a block diagram of one embodiment of a system **100** comprising a storage module **130** configured to manage a solid-state storage medium **110**. The storage module **130** may comprise an adaptive storage module **113**, a logical-to-physical translation layer **132**, storage metadata module **134**, log storage module **137**, groomer module **138**, a profiling module, and a data reconstruction module **170**. The storage module **130** may comprise software and/or hardware components. Portions of the storage module **130** (and/or the modules and/or components thereof) may be implemented using software modules, such as drivers, services, and/or the like. Other portions of the storage module **130** (and/or the modules and/or components thereof) may be implemented using hardware resources, such as FPGAs, processors, ASICs, hardware controllers, storage controllers, and the like.

**[0057]** The solid-state storage medium **110** may comprise a non-volatile, solid-state storage medium, such as flash memory, nano random access memory (nano RAM or NRAM), nanocrystal wire-based memory, silicon-oxide based sub-10 nanometer process memory, graphene memory, Silicon-Oxide-Nitride-Oxide-Silicon (SONOS), Resistive Random-Access Memory (RRAM), Programmable Metallization Cell (PMC), Conductive-Bridging RAM (CBRAM), Magneto-Resistive RAM (MRAM), Dynamic RAM (DRAM), Phase change RAM (PRAM), or the like. The solid-state storage medium **110** may comprise a plurality of physical storage units (e.g., storage cells) configured for persistent data storage. The physical storage units may be arranged in groups, such as pages, which may be partitioned into storage divisions, such as erase blocks. The solid-state storage medium **110** may comprise pages of any suitable size. The page size of a solid-state storage medium **110** may range from 512 b to 32 kb.

**[0058]** The adaptive storage module **113** may be configured to write data to and/or read data from the solid-state storage medium **110** via a bus **127**. The adaptive storage module **113** may comprise one or more hardware components, such as bus controllers, DMA controllers, storage controllers, storage media controllers, and the like. The adaptive storage module **113** may further comprise firmware, software modules, drivers, interface modules, and/or and the like.

**[0059]** The bus **127** may comprise a storage I/O bus for communicating data to/from the solid-state storage medium **110**, and may further comprise a control I/O bus for communicating addressing and other command and control information to the solid-state storage medium **110**.

**[0060]** The storage module **130** may comprise and/or be implemented on a computing device **101**. In some embodiments, portions of the storage module **130** may be internal to the computing device **101**; for example, portions of the storage module **130** and/or solid-state storage medium **110** may be connected using a system bus, such as a peripheral component interconnect express (PCI-e) bus, a Serial Advanced Technology Attachment (serial ATA) bus, or the like. The disclosure is not limited in this regard; in some embodiments, components of the storage module **130** may be external to the computing device **101**, and may be connected via a universal serial bus (USB) connection, an Institute of Electrical and Electronics Engineers (IEEE) 1394 bus (FireWire), an external PCI bus, Infiniband, or the like.

**[0061]** The computing device **101** may comprise a processor **103**, volatile memory **106**, and/or persistent storage **105**. The processor **103** may comprise one or more general and/or special purpose processing elements. The processor **103** may be configured to execute instructions loaded into the volatile memory **106** from the persistent storage **105**. Portions of one or more of the modules of the storage module **130** may be embodied as machine-readable instructions stored on the persistent storage **105**. The instructions may be configured for execution by the processor **103** to implement one or more of the modules and/or methods described herein.

**[0062]** One or more storage clients **104** may access storage services provided by the storage module **130** through a storage interface **131**. The storage interface **131** may comprise a block device interface, a virtualized storage interface, an object storage interface, a database storage interface, and/or other suitable interface and/or Application Programming Interface (API). The storage module **130** may further comprise a logical-to-physical translation layer **132** to map and/or associate identifiers of the storage client **104** with physical storage locations (e.g., physical addresses) on the solid-state storage medium **110**. The logical-to-physical translation layer **132** may provide for “any-to-any” mappings between logical identifiers and physical storage locations, such that data may be written and/or updated “out-of-place” on the solid-state storage medium **110**. As used herein, a physical address refers to an address (or other reference) capable of referencing a particular storage location on the solid-state storage medium **110**. Accordingly, a physical address may be a “media address.”

**[0063]** The storage module **130** may comprise a storage metadata module **134** configured to maintain storage metadata **135** pertaining to storage operations performed on the solid-state storage medium **110**. The storage metadata **135** may include, but is not limited to: an index comprising any-to-any mappings between logical identifiers of a logical address space and physical storage locations on the solid-

state storage medium **110**, a reverse index pertaining to the contents of the solid-state storage medium **110**, one or more validity bitmaps, reliability testing and/or status metadata, status information, such as error rate, retirement status, and so on. Portions of the metadata **135** may be stored on a volatile memory **106**. Alternatively, or in addition, portions of the metadata **135** may be periodically stored on a persistent storage medium, such as the persistent storage **105**, solid-state storage medium **110**, or the like.

**[0064]** The storage module **130** may comprise a request buffer **136** configured to buffer storage requests received via the storage interface **131**. The request buffer **136** may comprise an ordered buffer, such as a first-in-first-out (FIFO) or the like. The request buffer **136** may, therefore, be configured to maintain the order of incoming storage requests. As used herein, a storage request refers to one or more of a request to store, write, overwrite, modify, cache, delete, erase, read, and/or otherwise manage data by use of the storage module **130**. The storage module **130** may be configured to service the storage requests in the request buffer **136**. The storage module **130** may be configured to service the storage requests in the order they were received. Alternatively, the storage module **130** may be configured to reorder the storage requests to improve throughput and/or efficiency. The storage module **130** may be configured to reorder the storage requests to avoid data hazards, such as read-before-write, write-before-read, and so on.

**[0065]** The storage module **130** may comprise a log storage module **137** configured to store data in a “contextual format” on the solid-state storage medium **110**. As used herein, a “contextual format” refers to a data format in which a logical interface of a data segment is associated with the data segment on the solid-state storage medium **110**. For example, a contextual format may comprise a packet format that includes a header indicating one or more logical identifiers of a data segment, or the like. The contextual format may be used to reconstruct the mappings of the logical-to-physical translation layer **132** (and/or storage metadata **135**), such as any-to-any mappings between logical identifiers and physical storage locations, reverse index metadata, and the like.

**[0066]** In some embodiments, the storage module **130** comprises a groomer module **138** configured to perform grooming operations on the solid-state storage medium **110**. Grooming operations may include, but are not limited to: reclaiming storage resources, erasure, wear leveling, refreshing data stored on the solid-state storage medium **110**, and so on. The groomer module **138** may operate outside of the path for servicing other, higher-priority storage operations and/or requests. Therefore, the groomer module **138** may operate as an autonomous, background process, which may be suspended and/or deferred while other storage operations are in process. Alternatively, the groomer module **138** may operate in the foreground while other storage operations are being serviced. The groomer **138** may wear-level the non-volatile storage medium **110**, such that data is systematically spread throughout different storage locations, which may improve performance, data reliability, and avoid overuse and/or underuse of particular storage locations, thereby lengthening the useful life of the solid-state storage medium **110**. Grooming an erase block (or logical erase block) may comprise relocating valid data (if any) to other storage locations, erasing the erase block, and/or initializing the erase block for storage operations (e.g., marking the erase block with a sequence indicator, sequence number, timestamp, or the like).

The groomer module **138** may operate within a driver of the storage module **130**. Alternatively, or in addition, portions of the groomer module **138** may be implemented on the adaptive storage module **113** (e.g., as hardware components, firmware, programmable hardware components, or the like).

[0067] In some embodiments, the solid-state storage medium **110** may comprise one or more arrays **115** of solid-state storage elements **116A-Y**. As used herein, a solid-state storage array (or array) refers to a set of two or more independent columns **118**. A column **118** may comprise a solid-state storage element **116A-Y** that is communicatively coupled to the storage module **130** in parallel by the adaptive storage module **113** using, inter alia, the bus **127**. Rows **117** of the array **115** may comprise physical storage units of the respective columns **118** (solid-state storage elements **116A-Y**). As used herein, a solid-state storage element **116A-Y** includes, but is not limited to solid-state storage resources embodied as: a package, a chip, die, plane, printed circuit board, and/or the like. The solid-state storage elements **116A-Y** comprising the array **115** may be capable independent operation. Accordingly, a first one of the solid-state storage elements **116A** may be capable of performing a first storage operation while a second solid-state storage element **116B** performs a different storage operation. For example, the solid-state storage element **116A** may be configured to read data at a first physical address, while another solid-state storage element **116B** reads data at a different physical address.

[0068] A solid-state storage array **115** may also be referred to as a logical storage element (LSE). As disclosed in further detail below, an array or logical storage element **115** may comprise logical storage units (rows **117**). As used herein, a “logical storage unit” or row **117** refers to a logical construct combining two or more physical storage units, each physical storage unit on a respective column **118** of the array **115**. A logical erase block refers to a set of two or more physical erase blocks, a logical page refers to a set of two or more pages, and so on. In some embodiments a logical erase block may comprise erase blocks within respective logical storage elements **115** and/or banks. Alternatively, a logical erase block may comprise erase blocks within a plurality of different arrays **115** and/or may span multiple banks of solid-state storage elements.

[0069] The storage module **130** may further comprise an adaptive storage module **113** configured arrange data for storage on the solid-state storage array **115** according to an adaptive data layout. As used herein, an adaptive data layout refers to the layout of storage data segments within different portions of the solid-state storage array **115**. As used herein, a data segment refers to a quantum of structured or unstructured data; a data segment may, therefore, include, but is not limited to: data pertaining to a storage request, data corresponding to one or more logical identifiers, one or more data blocks, a data structure, such as a data packet, container, or the like, a data set, such as a data range, extent, or the like, an ECC codeword, such as an ECC syndrome, an ECC symbol, an ECC chunk, or the like, unstructured data, structured data, a data record, or the like.

[0070] The adaptive storage module **113** may be configured to store data in a horizontal layout, which may comprise storing data segments horizontally within rows **117** of the array (e.g., across a plurality of the solid-state storage elements **116A-Y** of the array **115**). A vertical layout may comprise storing data segments within respective columns **118** of the array **115** (e.g., within a single solid-state storage ele-

ments **116A-Y**). Other layouts may comprise storing data on subsets of the solid-state storage elements **116A-Y** (e.g., sets of two, four, or more solid-state storage elements **116A-Y**). The storage module **130** may comprise an adaptive storage profiling module **160** configured to determine an optimal data layout for the array **115** based on one or more of data read latency, stream latency, data access patterns, profiling information, desired data recovery characteristics, usage and/or the like.

[0071] In some embodiments, the storage module **130** further comprises a data recovery module **170**. The data recovery module **170** may be configured to recover data stored on the solid-storage storage medium **110**. The storage module **130** may be configured to generate error recovery data, such as ECC data, parity data, and/or the like. The error recovery data may be stored on the solid-state storage medium **110**. The ECC data may be used to detect and/or correct errors in data read from the array **115**. Data comprising uncorrectable errors may be reconstructed by use of parity data. Uncorrectable errors may result from failure of a portion of a particular column **118** (e.g., failure of an erase block, plane, die, or other portion of a particular solid-state storage element **116A-Y**). As disclosed in further detail herein, data corresponding to the failed column **118** may be reconstructed by use of data stored on other solid-state storage elements **116A-Y**. In some embodiments, reconstructing data of a failed solid-state storage element **116A-Y** may comprise reading one or more ECC codewords stored on other columns **118** of the array **115**, correcting errors within the one or more other ECC codewords (e.g., decoding the ECC codewords), and using the corrected ECC codewords to reconstruct data of the failed element **116A-Y**. The data reconstruction module **170** may comprise a parity substitution module **172** configured to reconstruct data of a failed column by use of error-corrected ECC codewords and/or parity data stored within the array **115**. In some embodiments, data of the failed column may be reconstructed without decoding and/or correcting the other ECC codewords; if the other columns **118** have low error rates (and/or low levels of wear), the reconstruction module **170** may be configured to perform the parity substitution operations without first decoding and/or correcting the other ECC codewords.

[0072] FIG. 2 is a block of one embodiment of a storage module **130** configured to manage data storage operations on a solid-state storage medium **110**. In some embodiments, the solid-state storage medium **110** may comprise one or more independent banks **119A-N** of solid-state storage arrays **115A-N**. As disclosed above, each array **115A-N** may comprise a plurality of solid-state storage elements communicatively coupled to the adaptive storage module **113** in parallel via a bus **127**.

[0073] The adaptive storage module **113** may comprise a request module **231** configured to receive storage requests from the storage module **130** and/or other storage clients **104**. The request module **231** may be configured to perform storage operations on the solid-state storage medium **110** in response to the requests, which may comprise transferring data to/from the storage module **130** and/or storage clients **104**. Accordingly, the request module **231** may comprise one or more direct memory access (DMA) modules, remote DMA modules, bus controllers, bridges, buffers, and the like.

[0074] The adaptive storage module **113** may comprise a write module **240** configured to process data for storage on the solid-state storage medium **110**. In some embodiments,

the write module 240 comprises one or more modules configured to process and/or format data for storage on the solid-state storage medium 110, which may include, but are not limited to: a packet module 242, a whiten module 244, an ECC write module 246, an adaptive write module 248, and a write buffer 250. In some embodiments, the write module 240 may further comprise a compression module, configured to compress data for storage on the solid-state storage medium 110, one or more encryption modules configured to encrypt data for storage on the solid-state storage medium 110, and so on. The read module 241 may comprise one or more modules configured to process and/or format data read from the solid-state storage medium 110, which may include, but are not limited to: a read buffer 251, an adaptive read module 245, an ECC read module 245, a dewhiten module 243, and a depacket module 241.

[0075] In some embodiments, the write module 240 comprises a write pipeline configured to process data for storage in a plurality of pipeline stages or modules, as disclosed herein. Similarly, in some embodiments, the read module 241 may comprise a read pipeline configured to process data read from the solid-state storage array 115 in a plurality of pipeline stages or modules, as disclosed herein.

[0076] The packet module 242 may be configured to generate data packets comprising data to be stored on the solid-state storage medium 110. The write module 240 may be configured to store data in a contextual format, as disclosed above. The contextual format may comprise storing data in a packet format in which a logical interface of the data is associated with the data on the solid-state storage medium 110. In some embodiments, the packet format may include a packet header comprising one or more logical identifiers of the data contained within the packet, or the like. The contextual format may further comprise associating data packets with sequence information, to define, inter alia, a log-order of data packets on the solid-state storage medium 110. The sequence information may comprise sequence numbers, timestamps, or other indicators that indicate an order of the data packet relative to other data packets stored on the solid state storage medium 110. The storage module 130 may use the log-based, contextual format of data stored on the solid-state storage medium 110 to reconstruct portions of the storage metadata 135, which may include, but is not limited to: reconstructing any-to-any mappings between logical identifiers and physical storage locations maintained by the logical-to-translation layer 132, a forward index, a reverse index, and/or the like.

[0077] In some embodiments, the packet module 242 may be configured to generate packets of arbitrary lengths and/or sizes in accordance with the size of storage requests received via the request receiver module 231 and/or configuration preferences. The packet module 242 may be configured to generate packets of one or more pre-determined sizes. In one embodiment, in response to a request to write 24k of data to the solid-state storage medium 110, the packet module 242 may be configured to generate 6 packets, each packet comprising 4k of the data; in another embodiment, the packet module 242 may be configured to generate a single packet comprising 24k of data in response to the request.

[0078] FIG. 3 depicts one embodiment of a packet format. A packet 310 may comprise a packet data segment 312 and a header 314. As disclosed above, the packet data segment 312 may comprise an arbitrary amount of data to be stored on the solid-state storage medium 110. The header 314 may com-

prise contextual metadata pertaining to the packet 310. In some embodiments, the header 314 includes a logical identifier indicator 315, which may indicate one or more logical identifier(s) associated with the data segment. The header 315 may include other metadata, which may include, but is not limited to: a packet type metadata, a packet size and/or length metadata, access control metadata, and so on. The packet 310 may be associated with sequence information 318, which may determine a log order of the packet 310 relative to other packets on the solid-state storage medium 110. As depicted in FIG. 3, the sequence information 318 may be stored separately from the packet 310. In some embodiments, the sequence information 318 may be marked the section of the solid-state storage medium 110 comprising the data packet 310 (e.g., erase block, logical erase block, row, or the like). Alternatively, or in addition, the sequence information 318 may be stored as part of the packet 310 (e.g., as a field within the header 314 of the packet 310).

[0079] The whiten module 244 may be configured to perform one or more whitening transformations on the data packets generated by the packet module 242. Data whitening may comprise decorrelating the data, which may provide wear-leveling benefits for certain types of solid-state storage medium 110. In some embodiments, the whiten module 244 is configured to encrypt data for storage on the solid-state storage medium 110 in one or more of a media encryption key, a user encryption key, or the like.

[0080] The ECC write module 246 may be configured to encode data packets generated by the packet module 242 into respective ECC codewords. As used herein, an ECC codeword refers data and corresponding error detection and/or correction information. The ECC write module 246 may be configured to implement any suitable ECC algorithm and may be configured to generate corresponding ECC information (e.g., ECC codewords), which may include, but are not limited to: data segments and corresponding ECC syndromes, ECC symbols, ECC chunks, and/or other structured and/or unstructured ECC information. ECC codewords may comprise any suitable error-correcting encoding, including, but not limited to: block ECC encoding, convolutional ECC encoding, Low-Density Parity-Check (LDPC) encoding, Gallager encoding, Reed-Solomon encoding, Hamming codes, Multidimensional parity encoding, Hamming codes, cyclic error-correcting codes, BCH codes, or the like. The ECC read module 245 may be configured to decode and/or correct ECC codewords generated by the ECC write module 246.

[0081] The ECC write module 246 may be configured to generate ECC codewords of a pre-determined size. Accordingly, a single packet may be encoded into a plurality of different ECC codewords and/or a single ECC codeword may comprise portions of two or more packets.

[0082] In some embodiments, the ECC write module 246 is configured to generate ECC codewords, each of which may comprise a data segment of length N and a syndrome of length S. For example, the ECC write module 246 may be configured to encode data segments into 240 byte ECC codewords, each ECC codeword comprising 224 bytes of data and 16 bytes of ECC data. In this embodiment, the ECC encoding may be capable of correcting more bit errors than the manufacturer of the solid-state storage medium 110 requires. In other embodiments, the ECC write module 246 may be configured to encode data in a symbolic ECC encoding, such that each data segment of length N produces a symbol of length X. The ECC

write module **246** may encode data according to a selected ECC “strength.” As used herein, the “strength” of an error-correcting code refers to the number of errors that can be detected and/or corrected by use of the error correcting code. In some embodiments, the strength of the ECC encoding implemented by the ECC write module **246** may be adaptive and/or configurable. In some embodiments, the strength of the ECC encoding may be selected according to the reliability and/or error rate of the solid-state storage medium **110**. As disclosed in further detail herein, the strength of the ECC encoding may be independent of the partitioning of the solid-state storage medium **110**, which may allow the storage module **130** to select a suitable ECC encoding strength based on the conditions of the solid-state storage medium **110**, user requirements, and the like, as opposed to static and/or predetermined ECC settings imposed by the manufacturer of the medium **110**.

[0083] FIG. 4 depicts one embodiment of data flow **400** between the packet module **242** and an ECC write module **246**. For clarity, and to avoid obscuring the details of the depicted embodiment, other modules of the write module **240** are omitted (e.g., whitener module **244**). The packet module **242** may be configured to generate packets **310A-310N** in response to one or more requests to store data on the solid-state storage medium **110**. The packets **310A-N** may comprise respective packet data segments **312A**, **312B**, and **314N**. The packets **310A-N** may further comprise contextual metadata embodied in respective headers **314A**, **312B**, and **314N**. The packets **310A-N** may be processed by, inter alia, the ECC write module **246** to generate ECC codewords. In the FIG. 4 embodiment, the ECC codewords comprise ECC codewords **420A-420X**, each of which may comprise a portion of one or more of the packets **310A-N** and a syndrome (not shown). In other embodiments, the ECC codewords may comprise ECC symbols or the like.

[0084] As illustrated in FIG. 4, the packets **310A-N** may vary in size in accordance with the size of the respective packet data segments **312A-N** and/or header information **314A-N**. Alternatively, in some embodiments, the packet module **242** may be configured to generate packets **310A-N** of a fixed, uniform size.

[0085] The ECC write module **246** may be configured to generate ECC codewords **420A-N** having a uniform, fixed size; each ECC codeword **420A-N** may comprise N bytes of packet data and S syndrome bytes, such that each ECC codeword **420A-N** comprises N+S bytes. In some embodiments, each ECC codeword comprises 240 bytes, and includes 224 bytes of packet data (N) and 16 bytes of error correction code (S). The disclosed embodiments are not limited in this regard, however, and could be adapted to generate ECC codewords **420A-N** of any suitable size, having any suitable ratio between N and S. Moreover, the ECC write module **242** may be further adapted to generate ECC symbols, or other ECC codewords, comprising any suitable ratio between data and ECC information.

[0086] As depicted in FIG. 4, the ECC codewords **420A-N** may comprise portions of one or more packets **310A-N**; ECC codeword **420D** comprises data of packets **310A** and **310B**. The packets **310A-N** may be spread between a plurality of different ECC codewords **420A-N**: ECC codewords **420A-D** comprise data of packet **310A**; ECC codewords **420D-H** comprise data of packet **310B**; and ECC codewords **420X-420Z** comprise data of packet **310N**.

[0087] Referring back to FIG. 2, the write module **240** may further comprise an adaptive write module **248** configured to buffer data to storage on one or more of the solid-state storage arrays **115A-N**. As disclosed in further detail below, the adaptive write module **248** may be configured to store data within one or more columns **118** of a solid-state storage array **115**. The adaptive write module **248** may be further configured to generate parity data associated corresponding to the layout and/or arrangement of the data. As disclosed in further detail below, the parity data may be configured to protect data stored within respective rows **117** of the solid-state storage array **115A-N**, and may be generated in accordance with an adaptive storage layout implemented by the adaptive storage module **113**.

[0088] In some embodiments, the write module **240** further comprises a write buffer **250** configured to buffer data for storage within respective page write buffers of the solid-state storage medium **110**. The write buffer **250** may comprise one or more synchronization buffers to synchronize a clock domain of the adaptive storage module **113** with a clock domain of the solid-state storage medium **110** (and/or bus **127**).

[0089] The log storage module **137** may be configured to select storage location(s) for data storage and/or may provide addressing and/or control information to the solid-state storage medium **110** via the bus **127**. Accordingly, the log storage module **137** may provide for storing data sequentially at an append point within the physical address space of the solid-state storage medium **110**. The physical address at which a particular data segment is stored may be independent of the logical interface (e.g., logical identifier) of the data segment. The logical-to-physical translation layer **132** may be configured to associate the logical interface of data segments (e.g., logical identifiers of the data segments) with the physical address(es) of the data segments on the solid-state storage medium **110**. In some embodiments, the logical-to-physical translation layer **132** may leverage storage metadata **135** to perform logical-to-physical translations; the storage metadata **135** may include a forward index comprising arbitrary, any-to-any mappings between logical identifiers and physical addresses. The storage metadata **135** may be maintained in volatile memory, such as the volatile memory **106**. In some embodiments, the storage metadata module **134** is configured to periodically store portions of the storage metadata **135** on a persistent storage medium, such as the solid-state storage medium **110**, persistent storage **105**, or the like.

[0090] The adaptive storage module **113** may further comprise a read module **241** that is configured to read data from the solid-state storage medium **110** in response to requests received via the request module **231**. The read module **241** may be configured to process data read from the solid-state storage medium **110**, and provide the processed data to the storage module **130** and/or a storage client **104** (by use of the request module **231**). The read module **241** may comprise one or more modules configured to process and/or format data stored on the solid-state storage medium **110**, which may include, but are not limited to: read buffer **251**, an adaptive read module **247**, ECC read module **245**, a dewhitener module **243**, and a depacket module **241**. In some embodiments, the read module further includes a decompression module, configured to decompress compressed data stored on the solid-state storage medium **110**, one or more decryption modules configured to decrypt encrypted data stored on the solid-state storage medium **110**, and so on. Data processed by the read

module **241** may flow to the storage module **130** and/or storage client **104** via the request module **231**, and/or other interface or communication channel (e.g., the data may flow directly to/from a storage client via a DMA or remote DMA module of the storage module **130**).

[0091] Read requests may comprise and/or reference the logical interface of the requested data, such as a logical identifier, a range and/or extent of logical identifiers, a set of logical identifiers, or the like. The physical addresses associated with data of the request may be determined based, at least in part, upon the logical-to-physical translation layer **132** (and/or the storage metadata **135**), metadata pertaining to the layout of the data on the solid-state storage medium **110**, and so on. Data may stream into the read module **241** via a read buffer **251**. The read buffer **251** may correspond page read buffers to a solid-state storage array **115A-N** of one of the banks **119A-N**. The read buffer **251** may comprise one or more synchronization buffers configured to synchronize a clock domain of the adaptive storage module **113** with a clock domain of the solid-state storage medium **110** (and/or bus **127**).

[0092] The adaptive read module **247** may be configured to reconstruct one or more data segments from the contents of the read buffer **251**. Reconstructing the data segments may comprise recombining and/or reordering contents of the read buffer (e.g., ECC codewords) read from various columns **118** in accordance with a layout of the data on the solid-state storage arrays **115A-N** as indicated by the storage metadata **135**. In some embodiments, reconstructing the data may comprise stripping data associated with one or more columns **118** from the read buffer, reordering data of one or more columns **118**, and so on.

[0093] The read module **241** may comprise an ECC read module **245** configured to detect and/or correct errors in data read from the solid-state storage medium **110** using, inter alia, the ECC encoding of the data (e.g., as encoded by the ECC write module **246**), parity data (e.g., using parity substitution), and so on. As disclosed above, the ECC encoding may be capable of detecting and/or correcting a pre-determined number of bit errors, in accordance with the strength of the ECC encoding. The ECC read module **245** may be capable of detecting more bit errors than can be corrected.

[0094] The ECC read module **245** may be configured to correct any "correctable" errors using the ECC encoding. In some embodiments, the ECC read module **245** may attempt to correct errors that cannot be corrected by use of the ECC encoding using other techniques, such as parity substitution, or the like. Alternatively, or in addition, the ECC read module **245** may attempt to recover data comprising uncorrectable errors from another source. For example, in some embodiments, data may be stored in a RAID configuration. In response to detecting an uncorrectable error, the ECC read module **245** may attempt to recover the data from the RAID, or other source of redundant data (e.g., a mirror, backup copy, or the like).

[0095] In some embodiments, the ECC read module **245** may be configured to generate an interrupt in response to reading data comprising uncorrectable errors. The interrupt may comprise a message indicating that the requested data is in error, and may indicate that the ECC read module **245** cannot correct the error using the ECC encoding. The message may comprise the data that includes the error (e.g., the "corrupted data").

[0096] The interrupt may be caught by the storage module **130** or other process. In some embodiments, the interrupt is received by the data reconstruction module **170**, which, in response, may be configured to reconstruct the data using parity substitution, or other reconstruction technique, as disclosed herein. Parity substitution may comprise iteratively replacing portions of the corrupted data with a "parity mask" (e.g., all ones) until a parity calculation associated with the data is satisfied. The masked data may comprise the uncorrectable errors, and may be reconstructed using other portions of the data in conjunction with the parity data. Parity substitution may further comprise reading one or more ECC codewords from the solid-state storage array **115A-N** (in accordance with an adaptive data structure layout on the array **115**), correcting errors within the ECC codewords (e.g., decoding the ECC codewords), and reconstructing the data by use of the corrected ECC codewords and/or parity data. In some embodiments, the corrupted data may be reconstructed without first decoding and/or correcting errors within the ECC codewords.

[0097] Alternatively, data reconstruction module **170** may be configured to replace the corrupted data with another copy of the data, such as a backup or mirror copy, and then may use the replacement data of the requested data packet or return it to the read module **241**. In another embodiment, the storage module **130** stores data in a RAID configuration, from which the corrupted data may be recovered, as described above.

[0098] As depicted in FIG. 2, the solid-state storage medium **110** may be arranged into a plurality of independent banks **119A-N**. Each bank may comprise a plurality of solid-state storage elements arranged into respective solid-state storage arrays **115A-N**, as disclosed above. The banks **119A-N** may be configured to operate independently; the adaptive storage module **113** may configure a first bank **119A** to perform a first storage operation while a second bank **119B** is configured to perform a different storage operation. The adaptive storage module **113** may further comprise a bank controller **252** configured to selectively route data and/or commands between the adaptive storage module **113** and the banks **119A-N**. In some embodiments, adaptive storage module **113** may be configured to read data from a bank **119A** while filling the write buffer **250** for storage on another bank **119B** and/or may interleave one or more storage operations between one or more banks **119A-N**. Further embodiments of multi-bank storage operations and data pipelines are disclosed in U.S. Patent Application Publication No. 2008/0229079 (U.S. patent application Ser. No. 11/952,095), entitled, "Apparatus, System, and Method for Managing Commands of Solid-State Storage Using Bank Interleave," filed Dec. 6, 2007 for David Flynn et al., which is hereby incorporated by reference in its entirety.

[0099] As disclosed above, the groomer module **138** may be configured to reclaim storage resources of the solid-state storage medium **110**. The groomer module **138** may operate as an autonomous, background process, which may be suspended and/or deferred while other storage operations are in process. The log storage module **137** and groomer module **138** may manage storage operations so that data is systematically spread throughout a physical address space of the solid-state storage medium **110**, which may improve performance, data reliability, and avoid overuse and underuse of any particular storage locations, thereby lengthening the useful life of the solid-state storage medium **110** (e.g., wear-leveling, etc.). Accordingly, in some embodiments, the storage module

**130** treats the physical address space of the solid-state storage medium **110** as a cycle. Data is incrementally appended to the solid-state storage medium **110** from an initial append point, which may correspond to a particular physical address within one or more of the banks **119A-N** (e.g., physical address **0** of bank **119A**). Upon reaching the end of the physical address space (e.g., physical address **N** of bank **119N**), the append point reverts to the initial position (or next available storage location).

**[0100]** Operations to overwrite and/or modify data stored on the solid-state storage medium **110** may be performed “out-of-place.” The obsolete version of the data may remain on the storage medium **110** while the updated version of the data may be appended at the append point. Similarly, an operation to delete, erase, or TRIM data from the solid-state storage medium **110** may comprise indicating that the data is invalid (e.g., does not need to be retained on the solid-state storage medium **110**). Marking data as invalid may comprise modifying a mapping between the logical identifier of the data and the physical address of the invalid data, marking the physical address as invalid in a reverse index, or the like.

**[0101]** The groomer module **138** may be configured to select selections of the solid-state storage medium **110** for recovery. As used herein, a “section” of the solid-state storage medium **110** may include, but is not limited to: an erase block, a logical erase block, a die, a plane, one or more pages, a portion of a solid-state storage element **116A-Y**, a portion of a row **117** of a solid-state storage array **115**, or the like. A section may be selected for grooming in response to various criteria, which may include, but are not limited to: age criteria (e.g., data refresh), error metrics, reliability metrics, wear metrics, resource availability criteria, an invalid data threshold, or the like. A grooming or storage recovery operation may comprise relocating valid data on the section (if any). The operation may further comprise preparing the section for reuse, which may comprise erasing the section, marking the section with a sequence indicator, such as the sequence indicator **318**, and/or placing the section in a queue of storage sections that are available to store data. The groomer module **138** may be configured to schedule grooming operations with other storage operations and/or requests. In some embodiments, the adaptive storage module **113** may comprise a groomer bypass (not shown) configured to relocate data from a storage section by transferring data read from the section from the read module **241** directly into the write module **240** without being routed out of the adaptive storage module **113**.

**[0102]** The adaptive write module **248** may be further configured to manage out-of-service conditions on the solid-state storage medium **110**. As used herein, a section of the solid-state storage medium **110** that is “out-of-service” (OOS) refers to a section that is not currently being used to store valid data. The storage module **130** may be configured to monitor storage operations performed on the solid-state storage medium **110** and/or actively scan the solid-state storage medium **110** to identify sections that should be taken out of service. The storage metadata **135** may comprise OOS metadata that identifies OOS sections of the solid-state storage medium **110**. The adaptive write module **248** may be configured to avoid OOS section by, inter alia, stream padding (and/or nonce) data to the write buffer such that padding data will map to the identified OOS sections. In some embodiments, the adaptive storage module **113** may be configured to manage OOS conditions by replacing OOS sections of the solid-state storage medium **110** with replacement sections.

Alternatively, or in addition, a hybrid OOS approach may be employed. The padding approach to managing OOS conditions may be used in portions of the solid-state storage medium **110** comprising a relatively small number of OOS storage divisions; as the number of OOS sections increases, the solid-state adaptive storage module **113** may replace one or more of the OOS sections with replacements. Further embodiments of apparatus, systems, and methods for detecting and/or correcting data errors, and managing OOS conditions, are disclosed in U.S. Patent Application Publication No. 2009/0287956 (U.S. application Ser. No. 12/467,914), entitled, “Apparatus, System, and Method for Detecting and Replacing a Failed Data Storage,” filed May 18, 2009, and U.S. Patent Application Publication No. 2013/0019072 (U.S. application Ser. No. 13/354,215), entitled, “Apparatus, System, and Method for Managing Out-of-Service Conditions,” filed Jan. 19, 2012 for John Strasser et al, each of which is hereby incorporated by reference in its entirety.

**[0103]** As disclosed above, the solid-state storage medium **110** may comprise one or more solid-state storage arrays **115A-N**. A solid-state storage array **115A-N** may comprise a plurality of independent columns **118** (respective solid-state storage elements **116A-Y**), which may be coupled to the adaptive storage module **113** in parallel via the bus **127**. Accordingly, storage operations performed on an array **115A-N** may be performed on each of the solid-state storage elements **116A-Y** comprising the array **115A-N**. Performing a storage operation on an array **115A-N** may comprise performing the storage operation on each of the plurality of solid-state storage elements **116** comprising the array **115A-N**: a read operation may comprise reading a physical storage unit (e.g., page) from a plurality of solid-state storage elements **116A-Y**; a program operation comprise programming a physical storage unit (e.g., page) on a plurality of solid-state storage elements **116A-Y**; an erase operation may comprise erasing a section (e.g., erase block) on a plurality of solid-state storage elements **116A-Y**; and so on. Accordingly, a program operation may comprise the write module **240** streaming data to program buffers of a plurality of solid-state storage elements **116A-Y** (via the write buffer **250** and bus **127**) and, when the respective program buffers are sufficiently full, issuing a program command to the solid-state storage elements **116A-Y**. The program command may cause one or more storage units on each of the storage elements **116A-Y** to be programmed in parallel.

**[0104]** FIG. 5A depicts one embodiment **500** of a solid-state storage array **115**. As disclosed above, the solid-state storage array **115** may comprise a plurality of independent columns **118**, each of which may correspond to a respective solid-state storage element **116A-Y**. The embodiment of a solid-state storage array **115** depicted in FIG. 5 comprises twenty five columns **118** (e.g., solid-state storage element **0 116A** through solid-state storage element **24 116Y**). The solid-state storage elements **116A-Y** comprising the array may be communicatively coupled to the adaptive storage module **113** in parallel by the bus **127**. The bus **127** may be capable of communicating data, address, and/or control information to each of the solid-state storage elements **116A-Y**. The parallel connection may allow the adaptive storage module **113** to manage the solid-state storage elements **116A-Y** as a single, logical storage element (array **115**), as described above.

**[0105]** The solid-state storage elements **116A-Y** may be partitioned into sections, such as physical storage divisions

**530** or physical erase blocks. Each erase block may comprise a plurality of physical storage units **532**, such as pages. The physical storage units **532** within a physical storage division **530** may be erased as a group. Although FIG. **5A** depicts a particular partitioning scheme, the disclosed embodiments are not limited in this regard, and could be adapted to use solid-state storage elements **116A-Y** partitioned in any suitable manner.

[**0106**] As depicted in FIG. **5A**, the columns **118** of the array **115** may correspond to respective solid-state storage elements **116A-Y**. Accordingly, the array **115** of FIG. **5A** comprises twenty five columns **118**. Rows of the array **117** may correspond to physical storage units **532** and/or **530** of a plurality of the columns **118**.

[**0107**] FIG. **5B** is a block diagram **501** of another embodiment of a solid-state storage array **115**. As disclosed above, the solid-state storage array **115** may comprise a plurality of rows **117**, which may correspond to storage units on a plurality of different columns **118** within the array **115**. The rows **117** of the solid-state storage array **115** may include logical storage divisions **540**, which may comprise physical storage divisions on a plurality of the solid-state storage elements **116A-Y**. In some embodiments, a logical storage division **540** may comprise a logical erase block, comprising physical erase blocks on each of the solid-state storage elements **116A-Y** in the array **115**. A logical page **542** may comprise physical storage units (e.g., pages) on a plurality of the solid-state storage elements **116A-Y**.

[**0108**] Storage operations performed on the solid-state storage array **515** may operate on multiple solid-state storage elements **516**: an operation to program data to a logical storage unit **542** may comprise programming data to each of twenty-five (25) physical storage units (e.g., one storage unit per non-volatile storage element **116A-Y**); an operation to read data from a logical storage unit **542** may comprise reading data from twenty-five (25) physical storage units (e.g., pages); an operation to erase a logical storage division **540** may comprise erasing twenty-five physical storage divisions (e.g., erase blocks); and so on. Since the columns **118** are independent, storage operations may be performed across different sets and/or portions of the array **115**. For example, a read operation on the array **115** may comprise reading data from physical storage unit **532** at a first physical address of solid-state storage element **116A** and reading data from a physical storage unit **532** at a different physical address of one or more other solid-state storage elements **116B-N**.

[**0109**] Arranging non-volatile storage elements **116A-Y** into a solid-state storage array **115** may be used to address certain properties of the solid-state storage medium **110**. Some embodiments may comprise asymmetric solid-state storage medium **110**; it may take longer to program data onto the solid-state storage elements **116A-Y** than it takes to read data therefrom (e.g., ten times as long). Moreover, in some cases, data may only be programmed to physical storage divisions **530** that have first been initialized (e.g., erased). Initialization operations may take longer than a program operations (e.g., ten times as long as a program, and by extension one hundred times as long as a read operation). Managing groups of solid-state storage elements **116A-Y** in an array **115** (and/or interleaved banks **119A-N** as disclosed herein), may allow the storage module **130** to address the asymmetric properties of the solid-state storage medium **110**. In some embodiments, the asymmetry in read, program, and/or erase operations is addressed by performing these opera-

tions on multiple solid-state storage elements **116A-Y** in parallel. In the embodiment depicted in FIG. **5B**, programming asymmetry may be addressed by programming twenty-five (25) storage units in a logical storage unit **542** in parallel. Initialization operations may also be performed in parallel. Physical storage divisions **530** on each of the solid-state storage elements **116A-Y** may be initialized as a group (e.g., as logical storage divisions **542**), which may comprise erasing twenty-five (25) physical erase blocks in parallel.

[**0110**] In some embodiments, portions of the solid-state storage array **115** may be configured to store data and other portions of the array **115** may be configured to store error detection and/or recovery information. Columns **118** used for data storage may be referred to as “data columns” and/or “data solid-state storage elements.” Columns used to store data error detection and/or recovery information may be referred to as a “parity column” and/or “recovery column.” The array **515** may be configured in an operational mode in which one of the solid-state storage elements **116Y** is used to store parity data, whereas other solid-state storage elements **116A-X** are used to store data. Accordingly, the array **115** may comprise data solid-state storage elements **116A-X** and a recovery solid-state storage element **116Y**. In this operational mode, the effective storage capacity of the rows (e.g., logical pages **542**) may be reduced by one physical storage unit (e.g., reduced from 25 physical pages to 24 physical pages). As used herein, the “effective storage capacity” of a storage unit refers to the number of storage units or divisions that are available to store data and/or the total amount of data that can be stored on a logical storage unit. The operational mode described above may be referred to as a “24+1” configuration, denoting that twenty-four (24) physical storage units **532** are available to store data, and one (1) of the physical storage units **532** is used for parity. The disclosed embodiments are not limited to any particular operational mode and/or configuration, and could be adapted to use any number of the solid-state storage elements **116A-Y** to store error detection and/or recovery data.

[**0111**] As disclosed above, the adaptive storage module **113** may be configured to interleave storage operations between a plurality of solid-state storage arrays **115A-N** of independent banks **119A-N**, which may further ameliorate asymmetry between erase, program, and read operations on the solid-state storage medium **110**. FIG. **5C** depicts one embodiment of a adaptive storage module **113** configured to manage logical erase blocks **540** that span multiple arrays **115A-N** of multiple banks **119A-N**. Each bank **119A-N** may comprise one or more solid-state storage arrays **115A-N**, which, as disclosed herein, may comprise a plurality of solid-state storage elements **116A-Y** coupled in parallel by a respective bus **127A-N**. The adaptive storage module **113** may be configured to perform storage operations on the storage elements **116A-Y** of the arrays **119A-N** in parallel and/or in response to a single command and/or signal.

[**0112**] Some operations performed by the adaptive storage module **113** may cross bank boundaries. The adaptive storage module **113** may be configured to manage groups of logical erase blocks **540** that include erase blocks of multiple arrays **115A-N** within different respective banks **119A-N**. Each group of logical erase blocks **540** may comprise erase blocks **531A-N** on each of the arrays **115A-N**. The erase blocks **531A-N** comprising the logical erase block group **540** may be erased together (e.g., in response to a single erase command and/or signal or in response to a plurality of separate erase

commands and/or signals). Performing erase operations on logical erase block groups **540** comprising large numbers of erase blocks **531A-N** within multiple arrays **115A-N** may further mask the asymmetric properties of the solid-state storage medium **110**, as disclosed above.

[0113] The adaptive storage module **113** may be configured to perform some storage operations within boundaries of the arrays **115A-N** and/or banks **119A-N**. In some embodiments, the read, write, and/or program operations may be performed within rows **117** of the solid-state storage arrays **115A-N** (e.g., on logical pages **542A-N** within arrays **115A-N** of respective banks **119A-N**). As depicted in FIG. 5C, the logical pages **542A-N** of the arrays **115A-N** may not extend beyond single arrays **115A-N** and/or banks **119A-N**. The log storage module **137** and/or bank interleave module **252** may be configured to append data to the solid-state storage medium **110** by interleaving and/or scheduling storage operations sequentially between the arrays **15A-N** of the banks **119A-N**.

[0114] FIG. 5D depicts one embodiment of storage operations that are interleaved between a solid-state storage arrays **115A-N** of respective banks **119A-N**. In the FIG. 5D embodiment, the bank interleave module **252** is configured to interleave programming operations between logical pages **542A-N** (rows **117**) of the arrays **115A-N** within the banks **119A-N**. As disclosed above, the write module **240** may comprise a write buffer **250**, which may have sufficient capacity to fill write buffers one or more logical pages **542A-N** of an array **115A-N**. In response to filling the write buffer **250** (e.g., buffering data sufficient to fill a portion of a logical page **542A-N**), the adaptive storage module **113** may be configured to stream the contents of the write buffer **250** to program buffers of the solid-state storage elements **116A-Y** comprising one of the banks **119A-N**. The solid-state adaptive storage module **113** may then issue a program command and/or signal to the solid-state storage array **115A-N** to store the contents of the program buffers to a specified logical page **542A-N**. The log storage module **137** and/or bank interleave module **252** may be configured to provide control and addressing information to the solid-state storage elements **116A-Y** of the array **115A-N** using a bus **127A-N**, as disclosed above.

[0115] The bank interleave module **252** may be configured to append data to the solid-state storage medium **110** by programming data to the arrays **115A-N** in accordance with a sequential interleave pattern. The sequential interleave pattern may comprise programming data to a first logical page (LP\_0) of array **115A** within bank **119A**, followed by the first logical page (LP\_0) of array **115B** within the next bank **119B**, and so on, until data is programmed to the first logical page LP\_0 of each array **115A-N** within each of the banks **119A-N**. As depicted in FIG. 5D, data may be programmed to the first logical page LP\_0 of array **115A** in bank **119A** in a program operation **243A**. The bank interleave module **252** may then stream data to the first logical page (LP\_0) of the array **115B** in the next bank **119B**. The data may then be programmed to LP\_0 of array **115B** bank **119B** in a program operation **243B**. The program operation **243B** may be performed concurrently with the program operation **243A** on array **115A** of bank **19A**; the adaptive storage module **113** may stream data to array **115B** and/or issue a command and/or signal for the program operation **243B**, while the program operation **243A** is being performed on the array **115A**. Data may be streamed to and/or programmed on the first logical page (LP\_0) of the arrays **115C-N** of the other banks **119C-119N** following the same sequential interleave pattern (e.g., after data is streamed and/

or programmed to LP\_0 of array **115A** of bank **119B**, data is streamed and/or programmed to LP\_0 of array **115C** of bank **119C** in program operation **243C**, and so on). Following the programming operation **243N** on LP\_0 of array **115N** within the last bank **119N**, the bank interleave controller **252** may be configured to begin streaming and/or programming data to the next logical page (LP\_1) of array **115A** within the first bank **119A**, and the interleave pattern may continue accordingly (e.g., program LP\_1 of array **115B** bank **119B**, followed by LP\_1 of array **115C** bank **119C** through LP\_1 of array **115N** bank **119N**, followed by LP\_2 of array **115A** bank **119A**, and so on).

[0116] Sequentially interleaving programming operations as disclosed herein may increase the time between concurrent programming operations on the same array **115A-N** and/or bank **119A-N**, which may reduce the likelihood that the adaptive storage module **113** will have to stall storage operations while waiting for a programming operation to complete. As disclosed above, programming operations may take significantly longer than other operations, such as read and/or data streaming operations (e.g., operations to stream the contents of the write buffer **250** to an array **115A-N** via the bus **127A-N**). The interleave pattern of FIG. 5D may be configured to avoid consecutive program operations on the same array **115A-N** and/or bank **119A-N**; programming operations on a particular array **115A-N** may be separated by N-1 programming operations on other banks (e.g., programming operations on array **115A** are separated by programming operations on arrays **115A-N**). As such, programming operations on array **119A** are likely to be complete before another programming operation needs to be performed on the array **119A**.

[0117] As depicted in FIG. 5D, the interleave pattern for programming operations may comprise programming data sequentially across rows **117** (e.g., logical pages **542A-N**) of a plurality of arrays **115A-N**. As depicted in FIG. 5E, the interleave pattern may result in interleaving programming operations between arrays **115A-N** of banks **119A-N**, such that the erase blocks of each array **115A-N** (erase block groups **EBG\_0-N**) are filled at the same rate. The sequential interleave pattern programs data to the logical pages of the first erase block group (**EBG\_0**) in each array **115A-N** before programming data to logical pages LP\_0 through LP\_N of the next erase block group (**EBG\_1**), and so on (e.g., wherein each erase block comprises 0-N pages). The interleave pattern continues until the last erase block group **EBG\_N** is filled, at which point the interleave pattern continues back at the first erase block group **EBG\_0**.

[0118] The erase block groups of the arrays **115A-N** may, therefore, be managed as logical erase blocks **540A-N** that span the arrays **115A-N**. Referring to FIG. 5C, a logical erase block group **540** may comprise erase blocks **531A-N** on each of the arrays **115A-N** within the banks **119A-N**. As disclosed above, managing groups of erase blocks (e.g., logical erase block group **540**) may comprise erasing each of the erase blocks **531A-N** included in the group **540**. In the FIG. 5E embodiment, erasing the logical erase block group **540A** may comprise erasing **EBG\_0** of arrays **115A-N** in banks **119A-N**, erasing a logical erase block group **540B** may comprise erasing **EBG\_1** of arrays **115A-N** in banks **119A-N**, erasing logical erase block group **540C** may comprise erasing **EBG\_2** of arrays **115A-N** in banks **119A-N**, and erasing logical erase block group **540N** may comprise erasing **EBG\_N** of arrays **115A-N** in banks **119A-N**. Other operations, such as groom-

ing, recovery, and the like may be performed at the granularity of the logical erase block groups 540A-N; recovering the logical erase block group 540A may comprise relocating valid data (if any) stored on EBG\_0 on arrays 115A-N in banks 517A-N, erasing the erase blocks of each EBG\_0 in arrays A-N, and so on. Accordingly, in embodiments comprising four banks 119A-N, each bank 119A-N comprising a respective solid-state storage array 115A-N comprising twenty five storage elements 116A-Y, erasing, grooming, and/or recovering a logical erase block group 540 comprises erasing, grooming, and/or recovering one hundred physical erase blocks 530. Although particular multi-bank embodiments are described herein, the disclosure is not limited in this regard and could be configured using any multi-bank architecture comprising any number of banks 119A-N of arrays 115A-N comprising any number of solid-state storage elements 116A-Y.

[0119] Referring back to FIG. 1, the storage module 130 may be configured to store data segments in one or more different arrangements and/or layouts within a solid-state storage array 115. In some embodiments, data may be stored “horizontally” within rows 117 of the array 115 (e.g., horizontally within logical storage units 542 of the array 115). Accordingly, a datastructure, such as an ECC codeword or packet, may be spread across a plurality of the storage elements 116A-Y comprising the array 115. In some embodiments, data may be stored horizontally within one or more “channels” within the array 115. As used herein, a channel refers to a subset of one or more independent columns 118 of the array 115. Data may be arranged horizontally within the channels. An array 115 comprising N columns 118 used for storing data may be divided into a configurable number of independent channels X, each comprising Y columns 118 of the array 115. In the FIG. 1 embodiment having a “24+1” configuration that comprises twenty four columns 118 for storing data, the channel configurations may include, but are not limited to: 24 channels each comprising a single column 118; twelve channels each comprising two solid-state storage elements; eight channels each comprising three solid-state storage elements; six channels each comprising 6 columns 118; and so on. In some embodiments, the array 115 may be divided into heterogeneous channels, such as a first channel comprising twelve columns 118 and six other channels each comprising two columns 118.

[0120] FIG. 6A is a block diagram of one embodiment of a system 600 for adaptive data storage. The system 600 may comprise a solid-state storage array 115 comprising twenty five solid-state storage elements 116A-Y operating in a “24+1” configuration, in which twenty four of the solid-state storage elements 116A-X are used to store data, and one storage element (116Y) is used to store parity data.

[0121] The write module 240 may comprise a packet module 242 configured to generate data packets comprising data for storage on the array 115, as disclosed above. In the FIG. 6A embodiment, the packet module 242 is configured to format data into a packet format 610, comprising a packet data segment 612 and metadata 614 (e.g., header). The header 614 may comprise a logical identifier associated with the packet data segment 612, a sequence number, or the like, as disclosed above. In the FIG. 6A embodiment, the packet module 242 is configured to generate packets 610 of a fixed size (520 byte packet data segment 612 and 8 bytes of metadata 614).

[0122] The ECC write module 246 is configured to generate ECC datastructures (ECC codewords 620) comprising portions of one or more packets 610 as disclosed above. The ECC codewords 620 may be of a fixed size. In the FIG. 6A example, each ECC codeword 620 comprises 224 bytes of packet data and a 16 byte error-correcting code or syndrome. Although particular sizes and/or configurations of packets 610 and ECC codewords are disclosed herein, the disclosure is not limited in this regard and could be adapted to use any size packets 610 and/or ECC codewords 620. Moreover, in some embodiments, the size of the datastructures (e.g., packets 610 and/or ECC codewords 620) may vary. For example, the size and/or contents of the packets 610 and/or ECC codewords 620 may be adapted according to out-of-service conditions, as disclosed above.

[0123] Data of the packet 610A may be included in a plurality of ECC codewords 620 (e.g., ECC codewords 621, 622, and 623). The ECC codeword 621 may comprise 224 bytes of the packet 610A, the ECC codeword 622 may comprise another 224 bytes of the packet 610A, and the ECC codeword 623 may comprise the remaining 72 bytes of the packet 610A and 152 bytes of the next packet 610B.

[0124] The adaptive write module 248 may be configured to layout data horizontally within rows of the array 115. The adaptive write module 248 may be configured to buffer and/or arrange data segments (e.g., the ECC codewords 621, 622, and 623) into 24 byte segments. The adaptive write module 248 may be capable of buffering one or more ECC codewords 620. For example, the write buffer 320 may comprise ten, 24 byte rows, which is sufficient to buffer a full 240 byte ECC codeword 620.

[0125] The adaptive write module 248 may be further configured to stream 24 byte segments to a parity module 637, which may be configured to generate a parity byte for each 24 byte segment. The adaptive write module 248 streams the resulting 25 bytes to the array 115 via the bank controller 252 and bus 127 (and/or write buffer 250, as disclosed above). The adaptive storage module 113 may be configured to stream data from the adaptive write module 248 to program buffers of the solid-state storage array 115 (e.g., stream to a program buffer of one of the solid-state storage elements 116A-Y). Accordingly, each cycle of bus 127 may comprise transferring a byte to the program buffer of a respective column 118; solid-state storage elements 116A-X receive data bytes and solid-state storage element 116Y receives the parity byte generated by the parity module 637. Data of the ECC codewords 620 may be byte-wise interleaved between the solid-state storage elements 116A-X; each solid-state storage element 116A-X receives 10 bytes of each 240 byte ECC codeword 620. Accordingly, the adaptive write module 248 may be configured to stream “data rows” 667 to the solid-state storage array 115. As used herein, a data row 667 refers to a data set comprising data for each of a plurality of columns 118 within the array 115. The data row 667 may comprise a byte of data for each column 0-23. The data row 667 may further comprise a parity byte corresponding to the data bytes (e.g., a parity byte corresponding to the data bytes for columns 0-23). The data row 667 may be streamed to respective program buffers of the solid-state storage elements 116A-Y on the bus 127. In the horizontal data configuration of FIG. 6A, streaming a 240 byte ECC codeword 620 to the array 115 may comprise streaming ten separate data rows 667 to the array

**115**, each data row comprising 24 data bytes (one for each data solid-state storage element **116A-X**) and a corresponding parity byte.

**[0126]** The storage location or offset **636** of the packet **610A** within the logical page **650A** may be determined based upon the horizontal layout of the data **610A** of the packet. The offset **636** may identify the location of the ECC codewords **621**, **622**, and/or **623** comprising the packet **610A** (and/or may identify the location of the last ECC codeword **623** comprising data of the packet **610A**). Accordingly, in some embodiments, the offset may be relative to one or more data-structures on the logical storage element **515** (e.g., a packet offset and/or ECC codeword offset). Another offset **638** may identify the location of the last ECC codeword of a next packet **620** (e.g., packet **610B**), and so on.

**[0127]** As depicted in FIG. 6A, each of the ECC codewords **621**, **622**, and **623** are horizontally spread across the storage elements **116A-Y** comprising the logical page **650A** (e.g., 10 bytes of the ECC codewords **621**, **622**, and **623** are stored on each solid-state storage element **116A-X**). Accessing the packet **610A** may, therefore, comprise accessing each of the ECC codewords **621**, **622**, and **623** (and each of the storage elements **116A-X**).

**[0128]** FIG. 6B depicts one embodiment of horizontal, adaptive data storage **601**. The FIG. 6B embodiment depicts a horizontal layout **601** of the ECC codeword **621** on the array **115** of FIG. 6A. Data  $D_0$  denotes a first byte of the ECC codeword **621**, and data  $D_{239}$  denotes the last byte (byte **240**) of the ECC codeword **621**. As illustrated in FIG. 6B, each column **118** of the solid-state storage array **115** comprises ten (10) bytes of the ECC codeword **621**, and the data of the ECC codeword **621** is horizontally spread across a row **117** of the array **115** (e.g., horizontally spread across solid-state storage elements **116A-X** of the array **115**). FIG. 6B also depicts a data row **667** as streamed to (and stored on) the solid-state storage array **115**. As illustrated in FIG. 6B, the data row **667** comprises a bytes **0** through **23** of the ECC codeword **D**, each stored on a respective one of the columns **118**. The data row **667** further comprises a parity byte **668** corresponding to the contents of the data row **667** (bytes  $D_0$  through  $D_{23}$ ).

**[0129]** Since the data is spread across the columns **0-23** (solid-state storage elements **116A-X**), reading data of the ECC codeword **621** may require accessing a plurality of columns **118**. Moreover, the smallest read unit may be an ECC codeword **620** (and/or packet **610**). Reading a packet **310** stored horizontally on the solid-state storage array **115** may, therefore, incur significant overhead. Referring back to FIG. 6A, reading the packet **610A** may require transferring data of the logical page **650A** into respective read buffers of the storage elements **116A-X** (e.g., storage elements **0** through **23**). Transferring the contents of a page into the read buffer may incur a latency of  $T_r$  (read latency). As used herein, read time or read latency  $T_r$  refers to the time needed to transfer the contents of a physical storage unit (e.g., physical page) into a read buffer of a solid-state storage element **116A-Y**. In the FIG. 6A embodiment, the read time  $T_r$  may, therefore, refer to the time required to transfer a physical page of each of the solid-state storage elements **116A-X** into a respective read buffer. Accordingly, the read time  $T_r$  of a logical storage unit **650** may correspond to the “slowest” read time of the constituent storage elements **116A-X**.

**[0130]** In the FIG. 6A embodiment, each ECC codeword comprises 240 bytes, and each packet comprises 520 bytes. The size of a logical page, however, may be much larger. For

example, each page may comprise 2 kbytes (or more), and as such, a logical page may comprise forty-eight (48) Kbytes. Accordingly, reading a packet may require transferring 48 kbytes of data to access 520 bytes (or less) of data.

**[0131]** Upon transferring the data into the respective read buffers, data may be streamed into the read module **241** by way of the 24 byte storage bus **127** (and bank controller **252**). The stream time ( $T_s$ ) may refer to the time required to stream the ECC codeword **620** (or packet **610**) into the pipeline **241**. In the horizontal layout of FIG. 6A, the stream time  $T_s$  may be ten (10) cycles of the bus **127** because, as disclosed above, each column **118** comprises ten (10) bytes of the ECC codeword **620**. Therefore, although the horizontal arrangement incurs a high retrieval overhead, the stream overhead is relatively low (only ten (10) clock cycles).

**[0132]** Given the data arrangement within the solid-state storage array **115**, and the latencies disclosed herein, an input/output operations per second (IOPS) metric may be quantified. The IOPS to read an ECC codeword **620** may be expressed as:

$$IOPS_r = \frac{C}{(T_r + T_s)} \quad \text{Eq. 1}$$

**[0133]** In Equation 1,  $T_r$  is the read time of the solid-state storage elements **116A-Y**,  $T_s$  is the stream time (e.g., the clock speed times the number of cycles required), and  $C$  is the number of independent columns used **118** to store the data. Equation 1 may be scaled by the number of independent banks **119A-N** available to the adaptive storage module **113**. In the Horizontal data structure layout of FIGS. 6A and 6B, Equation 1 may be expressed as:

$$IOPS_r = \frac{24}{(T_r + 10 * S_c)} \quad \text{Eq. 2}$$

**[0134]** In Equation 2, the number of columns is twenty-four (24), and  $S_c$  is the cycle time of the bus **127**. The cycle time is scaled by ten (10) since, as disclosed above, a horizontal 240 byte ECC codeword **620** may be streamed in ten (10) cycles of the bus **127**.

**[0135]** The storage module may be configured to store data in different configurations, layouts, and/or arrangements on the solid-state storage medium **110**. As disclosed above, in some embodiments, the adaptive write module **248** is configured to arrange data within respective independent columns, each comprising a subset of the columns **118** of the solid-state storage array **115** (e.g., subsets of the solid-state storage elements **116A-Y**). Alternatively, or in addition, the adaptive write module **248** may be configured to store data vertically within respective “vertical stripes.” The vertical stripes may have a configurable depth, which may a factor of the page size of the solid-state storage elements **116A-Y** comprising the array **115**.

**[0136]** FIG. 6C depicts another embodiment of a system **602** for adaptive data layout. In the FIG. 6C embodiment, the adaptive write module **248** may be configured to store data in a vertical layout within the array **115**. The adaptive write module **248** may be configured to buffer ECC codewords **620** for storage on respective columns **118** of the solid-state storage array **115** (including the ECC codewords **621**, **622**, and

623 disclosed herein). The ECC codewords 610 may be streamed to respective columns 118 of the array through a write buffer 250 (not shown). Accordingly, each cycle of the bus 127 may comprise streaming a byte of a different respective ECC codeword 610 to each of the columns 116A-X. The adaptive write module 248 may be further configured to generate parity data 637 corresponding to the different ECC codewords 610 for storage on a parity column (e.g., solid-state storage element 116Y). Accordingly, each stream cycle may comprise streaming a byte of a respective ECC codeword 610 to a respective column 118 along with a corresponding parity byte to a parity column 118.

[0137] As depicted in FIG. 6C, the adaptive write module 248 may be configured to buffer and rotate ECC codewords for vertical storage within respective columns 118 of the array 115: the ECC codeword 621 may stream to (and be stored vertically on) column 0 (solid-state storage element 116A), the ECC codeword 622 may be stored vertically on column 1 (solid-state storage element 116B), the ECC codeword 623 may be stored vertically on column 2 (solid-state storage element 116C), and so on (the ECC codeword 629 may be stored vertically in the column 23, solid-state storage element 116X). Column 24 (solid-state storage element 116Y) may be configured to store parity data corresponding to the ECC codewords, as disclosed above. Alternatively, the parity column 24 may be used to store additional ECC codeword data.

[0138] In some embodiments, the adaptive storage module 113 may comprise a plurality of packet modules 242 and/or ECC write modules 246 (e.g., multiple, independent write modules 240) configured to operate in parallel. Data of the parallel write modules 240 may flow into the adaptive write module 248 in a checkerboard pattern such that the data is arranged in the vertical format disclosed herein.

[0139] The vertical arrangement of FIG. 6C may store data of each ECC codeword 620 within a respective column 118 of the array 115. Accordingly, each data row 667 streamed to the array 115 may comprise a byte corresponding to a respective ECC codeword 620. The data row 667 may further comprise a corresponding parity byte; the data rows 667 may be configured to stream data of respective ECC codewords 660 to program buffers of respective data columns (e.g., solid-state storage elements 116A-Y), and a corresponding parity byte to a parity column (e.g., column 116Y). Accordingly, the data rows 667 may be stored with byte-wise parity information, each byte of a row 667, and stored within the solid-state storage elements 116A-X, may be reconstructed by use of the other bytes in the row 667 (and stored in other solid-state storage elements 116A-X) and the corresponding parity byte.

[0140] FIG. 6D depicts one embodiment of vertical, adaptive data storage 603. The FIG. 6D embodiment illustrates a vertical storage configuration within the solid-state storage array 115. As illustrated in FIG. 6D, data  $D_0$  through  $D_{239}$  of the ECC codeword 621 is stored vertically in column 0, Data  $O_0$  through  $O_{239}$  of ECC codeword 622 is stored vertically in column 1, Data  $Q_0$  through  $Q_{239}$  of ECC codeword 623 is stored vertically in column 2, and data  $Z_0$  through  $Z_{239}$  of ECC codeword 629 is stored vertically in column 23. The vertical storage configuration of other data of other ECC codewords 620 (R-Y) is also depicted.

[0141] FIG. 6D also depicts one embodiment of a data row 667 as streamed to, and stored on, the solid-state storage array 115. As illustrated in FIG. 6D, the data row 667 comprises a byte of each of a plurality of ECC codewords 620 (ECC codewords D, O, R, S, T, U . . . V, W, X, Y, and Z), each of

which is streamed to, and stored within, a respective column 118 (respective solid-state storage element 116A-X). The data row 667 further comprises a parity byte 668 corresponding to the data within the data row 667. Accordingly, the parity byte 668 corresponds to byte 0 of ECC codewords D, O, R, S, T, U . . . V, W, X, Y, and Z.

[0142] The vertical configuration of FIGS. 6C and 6D may result in a different IOPS metric. The vertical arrangement of the ECC codewords 620 may reduce overhead due to read time  $T_r$ , but may increase the stream overhead  $T_s$ . As data is streamed from a logical storage element 116A-Y, each byte on the bus 127 may correspond to a different, respective data segment (e.g., different ECC codeword 620). As such, twenty-four different ECC codewords 620 may be streamed in parallel (as opposed to streaming a single ECC codeword 620 as in the horizontal arrangement example). Moreover, since each column may be independently addressable, each transferred logical page may comprise data of a separate request (e.g., may represent data of twenty-four different read requests). However, since each ECC codewords is arranged vertically, the stream time  $T_s$  for an ECC codeword 620 may be increased; the stream time of 240 byte ECC codewords 620 in a vertical configuration may be 240 cycles, as opposed to 10 cycles in the fully horizontal layout of FIGS. 6A and 6B. The IOPS metric for a single ECC codeword 620, therefore may be represented as:

$$IOPS_r = \frac{1}{(T_r + 240 * S_r)} \tag{Eq. 3}$$

[0143] The reduced IOPS metric may be offset by the increased throughput (reduced read overhead) and/or different  $T_r$  and  $T_s$  latency times. These considerations may vary from device to device and/or application to application. Moreover, the IOPS metric may be ameliorated by the fact that multiple, independent ECC codewords 620 can be streamed simultaneously. Therefore, in some embodiments, the data layout used by the storage module 130 (and adaptive write module 248) may be configurable (e.g., by a user setting or preference, firmware update, or the like).

[0144] As disclosed above, in some embodiments, the adaptive write module 248 may be configured to layout and/or arrange data in an adaptive channel configuration. As used herein, an adaptive channel configuration refers to a data layout in which the columns 118 of the array 115 are divided into a plurality of independent channels, each channel comprising a set of columns 118 of the solid-state storage array 115. The channels may comprise subsets of the solid-state storage elements 116A-Y. In some embodiments, an adaptive channel configuration may comprise a fully horizontal data layout, in which data segments are stored within a channel comprising 24 columns 118 of the array 115, as disclosed in conjunction with FIGS. 6A and 6B. In other embodiments, the adaptive channel configuration may comprise a vertical configuration, in which data segments are stored within one of 24 different channels, each comprising a single column 118 of the array 115, as disclosed in conjunction with FIGS. 6C and 6D. In other embodiments, the adaptive storage module 248 may be configured to store data in other adaptive channel configurations and/or layouts on the solid-state storage array 115. FIG. 6E depicts another embodiment of a system 604 for adaptive data storage. In the FIG. 6E embodiment, the adaptive storage module 113 is configured to store

data structures adaptive channels comprising two solid-state storage elements **116A-Y** (two independent columns **118** per channel). Accordingly, data segments may be stored within two columns **118** of the array. In the FIG. 6E embodiment, the adaptive write module **248** may be configured to buffer twelve (12) ECC codewords **620** to stream to the array **115**. Each of the twelve ECC codewords **620** may stream to a respective set of two columns **118** within the array **115**.

[0145] In alternative adaptive channel configurations, the adaptive write module **248** may be configured to buffer  $24/N$  ECC codewords **620**, where  $N$  corresponds to the configuration of the adaptive channels used for each ECC codeword **620**. ECC codewords **620**, may be stored within channels comprising  $N$  independent columns **118**. Accordingly, the horizontal arrangement of FIGS. 6A and 6B could be referred to as an adaptive channel configuration comprising 24 column channels, and the vertical data structure configuration of FIGS. 6C and 6D may be referred to as an adaptive channel configuration comprising single column channels. The adaptive storage module **113** may be configured to arrange data in any suitable hybrid arrangement, including heterogeneous virtual columns. For example, the adaptive write module **248** may be configured to buffer six (6) ECC codewords **620** in a four (4) column adaptive channel configuration (e.g., store ECC codewords **620** across each of four (4) columns), buffer four (4) ECC codewords **620** in a six (6) column adaptive channel configuration (e.g. store ECC codewords **620** across each of six (6) columns), and so on.

[0146] In some embodiments, data structures may be arranged in adjacent columns **118** within the array **115** (e.g., a data structure may be stored in columns **0-4**). Alternatively, columns may be non-adjacent and/or interleaved with other data structures (e.g., a data structure may be stored on columns **0, 2, 4, and 6** and another data structure may be stored on columns **2, 3, 5, and 7**). The adaptive write module **248** may be configured to adapt the data arrangement to out-of-service conditions; if a column **118** (or portion thereof) is out of service, the adaptive storage module **113** may be configured to adapt the data arrangement accordingly (e.g., arrange data to avoid the out of service portions of the array **115**, as disclosed above).

[0147] FIG. 6E depicts an embodiment of data layout within channels comprising two column of the array **115** (e.g., two solid-state storage elements **116A-X** per channel). Accordingly, each data row **667** may comprise two bytes of each of twelve different ECC codewords **620** and a corresponding parity byte. The data row **667** may comprise two bytes of ECC codeword **621**, two bytes of ECC codeword **622**, two bytes of ECC codeword **623**, and so on. On each cycle of the bus **127**, two bytes of each ECC codeword **620** (e.g., ECC codewords **621, 622, 623, 629**, and so) on are transferred to program buffers of respective solid-state storage elements **116A-X**. Data of the ECC codeword **D 621** may be streamed to a first channel comprising columns **0 and 1** (solid-state storage elements **116A-B**), the ECC codeword **622** may be streamed to a second channel comprising columns **2 and 3** (solid-state storage elements **116C-D**), the ECC codeword **623** may be streamed to a third channel comprising columns **4 and 5** (solid-state storage elements **116E-F**), the ECC codeword **629** may be streamed to a last channel comprising columns **22 and 23** (solid-state storage elements **116W-X**), and so on.

[0148] FIG. 6F depicts one embodiment **605** of a data structure configuration for the two column channel embodiment of

FIG. 6E. As illustrated in FIG. 6F, data of ECC codeword **D 621** may be stored within a channel comprising columns **0 and 1**, data of ECC codeword **O 622** may be stored within a channel comprising columns **2 and 3**, data of ECC codeword **Q 623** may be stored within a channel comprising columns **4 and 5**, and so on. FIG. 6F further depicts a data row **667**. The data row **667** of FIG. 6F may include two bytes of each of twelve different ECC codewords **D, O, Q . . . Y, and Z**. The data row **667** may further comprise a parity byte **668** corresponding to the contents of the data row **667**, as disclosed above.

[0149] The stream time  $T_s$  of an ECC codeword **620** in the FIG. 6E embodiment may be 120 cycles of the bus **127** (e.g.,  $240/N$  cycles). An IOPS metric of the two (2) column hybrid arrangement of FIG. 6E may be represented as:

$$IOPS_r = \frac{2}{(T_r + 120 * S_c)} \quad \text{Eq. 4}$$

[0150] The IOPS metric may be modified according to a number of data structures that can be read in parallel. The two-column channel configuration of FIG. 6E may enable 12 different ECC codewords (and/or packets) to be read from the array **115** concurrently.

[0151] The adaptive data structure configurations disclosed herein may affect error detection and/or data recovery operations. In a horizontal data alignment, data of each ECC codeword **620** may be spread across the columns **118** of the array **115** (e.g., ten bytes on each of twenty four solid-state storage elements **116A-X**). Therefore, if an uncorrectable ECC error is encountered, identifying the source of the error may comprise performing an iterative parity substitution across each of the twenty four storage elements **116A-X** (e.g., reconstruct the ECC codeword **620** from parity data while omitting data of a respective storage element **116A-X** until the source of the error is identified). Moreover, since the ECC codewords **620** cannot be corrected until data of the failed column is recovered, parity reconstruction may aggregate errors in other columns **118**.

[0152] By contrast, when data is arranged vertically as in FIGS. 6C and 6D, the source of the error may be immediately determined without iterative parity substitution; since all of the data of the ECC codeword **620** is stored within a single solid-state storage element **116A-X**, failure to validate an ECC codeword **620** by the ECC read module **245** indicates that the corresponding column **118** within the array is the source of the uncorrectable error.

[0153] As disclosed above, a suitable data arrangement may be selected, at least in part, based upon the ECC algorithm in use (e.g., the size of the ECC codewords **620**, ratio between data and syndrome, and so on). In some embodiments, the adaptive storage module **113** may be configured to implement a symbolic ECC algorithm. For example, the ECC write module **246** may be configured generate ECC symbols (e.g., 8 bit ECC symbols), which may be individually streamed to solid-state storage array **115**, as disclosed herein. Since the ECC symbols each fall within a single column, the adaptive storage module **113** may be configured to arrange the ECC symbols in any of the horizontal, vertical, and/or hybrid arrangements described above. Alternatively, or in addition, the data arrangement may be selected according to other data structures within the ECC symbols, such as packets **610**, or the like. For example, an ECC symbol arrangement

may be configured to store ECC symbols of a packet **610** horizontally, vertically, and/or in a hybrid arrangement, as described above. Other ECC symbol sizes (e.g., 16 bit symbols, 32 bit symbols, and so on), may be arranged according to a horizontal, vertical, and/or hybrid arrangement, as disclosed herein.

**[0154]** In some embodiments, vertical data structure configuration may provide benefits for data reconstruction. In particular, vertical data structure layout and/or arrangement may avoid error aggregation issues. Referring back to FIG. **6D**, the data recovery module **170** may be configured to reconstruct data of a vertically arranged ECC codeword **620** by reading ECC codewords **620** on other columns **118** of the array **115**, correcting errors in the other ECC codewords **620** (if any) by, inter alia, decoding the other ECC codewords **620** using the ECC read module **245**, and using the corrected and/or decoded ECC codewords and parity data of column **24** to reconstruct the ECC codeword **620** within the failed column **118**. Use of corrected and/or decoded ECC codewords, as opposed to portions of uncorrected ECC codeword data **620**, may prevent errors from being aggregated and/or included in the reconstructed ECC codeword.

**[0155]** In the FIG. **6D** data structure configuration, if column **0** comprising ECC codeword D **621** fails, such that the ECC codeword D **621** cannot be read from the array, the reconstruction module **170** may be configured to reconstruct the ECC codeword **621** by: reading ECC codewords O through Z from columns **1** through **23** (and parity data of column **24**); correcting errors in the ECC codewords O through Z (if any) by use of the ECC read module **245**; and reconstructing data of the ECC codeword D **621** using the corrected ECC codewords O through Z and the parity data of column **24**. Accordingly, the data used to correct ECC codeword D **621** (ECC codewords O through Z) may be free from correctable errors, and as such, such errors may not be reflected in the reconstructed data comprising ECC codeword D **621**.

**[0156]** Hybrid, independent channel data structure layouts may provide similar benefits. For example, identifying errors in a two (2) column hybrid may only require iterative substitution between two (2) columns, errors in a four (4) column hybrid may only require iterative substitution between four (4) columns, and so on. Referring back to FIG. **6F**, identifying the source of an uncorrectable error in the ECC codeword D **621** may comprise iterative parity substitution between two columns **0** and **1**.

**[0157]** Hybrid, independent channel configurations may also benefit from reduced error aggregation during data reconstruction. Referring to the two column channel embodiment of FIGS. **6E** and **6F**, ECC codewords **620** may be stored within channels comprising two columns **118** of the array **115**. Accordingly, reconstructing data of a failed column of one of the channels may comprise reading data of other ECC codewords **620** on other columns of the array **115**, correcting errors within the other ECC codewords **620** (if any), and using the corrected ECC codewords **620**, data of the valid column of the channel, and the parity data to reconstruct data of the failed column **118**. For example, reconstructing data of failed column **0** comprising ECC codeword D **621** may comprise: reading data of ECC codewords O through Z on columns **2** through **23**, correcting errors within the ECC codewords **622**, **623**, through **629** (if any) by use of the ECC read module **245**; and reconstructing data of column **0** by use of data read from column **1**, the corrected ECC codewords of columns **2**

through **23**, and the parity data of column **24**. The only source of potential uncorrected errors is the other columns within the channel with the failed column **0** (column **1**). Accordingly, data reconstructing in the FIGS. **6E** and **6F** embodiment incorporates errors from only a single column, as opposed to aggregating errors from 23 other columns as in the horizontal data structure layout of FIGS. **6A** and **6B**.

**[0158]** The size of the data structures, such as the ECC codewords **620** and/or packets **610**, may be adapted according to the data arrangement implemented by adaptive write module **248**. For example, the size of the ECC codewords **620** may be selected to minimize wasted overhead when ECC codewords **620** are stored in a horizontal arrangement on twenty four storage elements **515**. However, in other data arrangement embodiments, other data structure sizes may be selected. For example, in the vertical layout of FIGS. **6C** and **6D**, the size of the ECC codeword **620** may be adapted according to the “depth” of the columns (e.g., the page size of each solid-state storage element). Hybrid, independent channel configurations may involve similar sizing considerations. In some embodiments, the size of the ECC codewords **620** (e.g., the ratio of data to syndrome) may be used to determine a suitable data arrangement. For example, given a particular ECC codeword size, a data arrangement that minimizes wasted overhead, while providing an acceptable IOPS metric, may be identified based on, inter alia, the depth of physical storage units of the solid-state storage medium **110**.

**[0159]** Table 1 illustrates various configurations of adaptive channel data layout embodiments used with different data structure sizes (240 and 960 byte ECC codewords **620**), as disclosed herein:

Adaptive Data Configuration	Independent Channels/ Codewords/ Read	T <sub>s</sub> : 240 Byte Data Structures	T <sub>s</sub> : 960 Byte Data Structures
1 of 24 (vertical, FIGS. 6C and 6D)	1	240	960
2 of 12 (hybrid, FIGS. 6E and 6F)	2	120	480
3 of 8	3	80	320
4 of 6	4	60	240
2 of 3 and 3 of 6	5	48	192
6 of 4	6	40	160
4 of 3 and 3 of 4	7	34	137
8 of 3	8	30	120
4 of 3 and 5 of 2 and extra 2 of 1	9	27	107
4 of 3 and 6 of 2	10	24	96
4 of 3 and 5 of 2 and 2 of 1	11	22	87
12 of 2	12	20	80
4 of 3 and 3 of 2 and 6 of 1	13	18	74
4 of 3 and 2 of 2 and 8 of 1	14	17	69
4 of 3 and 1 of 2 and 10 of 1	15	16	64
4 of 3 and 12 of 1	16	15	60
3 of 3 and 14 of 1 and extra 1 of 1	17	14	56
3 of 3 and 15 of 1	18	13	53
2 of 3 and 18 of 1	20	12	48
1 of 3 and 20 of 1 and extra 1 of 1	21	11	46
1 of 3 and 21 of 1	22	11	44
1 of 2 and 22 of 1	23	10	42
24 of 1 (horizontal, FIGS. 6A and 6B)	24	10	40

**[0160]** As disclosed herein, storage of data structures in vertical configurations may improve error detection, error correction and/or data reconstruction performance. However, horizontal storage configurations may provide performance benefits in certain situations (e.g., reduce stream time). Accordingly, in some embodiments, the storage module may

be configured to store data structures in an adaptive vertical stripe configuration. As used herein, a vertical stripe configuration refers to storing data structures vertically within vertical stripes having a predetermined depth. Multiple vertical stripes may be stored within rows 117 of the array 115. The depth of the vertical stripes may, therefore, determine read-level parallelism, whereas the vertical ECC configuration may maximize error detection, correction, and/or reconstruction benefits.

[0161] FIG. 6G depicts one embodiment of a vertical stripe data configuration 606 within a logical page 542 (row 117) of a solid-state storage array 115. As disclosed above, a vertical stripe may comprise vertically arranged data structures within respective columns 118 of the array 115. The vertical stripes 646A-N have a configurable depth or length. In the FIG. 6G embodiment, the vertical stripes 646A-N are configured to have a depth sufficient to store four ECC codewords. In some embodiments, the depth of the vertical stripes 646A-N corresponds to an integral factor of ECC codeword size relative to a page size of the solid-state storage medium 110.

[0162] In the FIG. 6G embodiment, the page size of the solid-state storage medium 110 may be 16 kb, each page may be configured to hold four vertical stripes 646A-N, and each vertical stripe may be configured to hold four 1 kb vertically aligned ECC codewords. The disclosed embodiments are not limited in this regard, however, and could be adapted to use any solid-state storage medium 110 having any page size in conjunction with any ECC codeword size and/or vertical stripe depth.

[0163] The depth of the vertical stripes 646A-N and the size of typical read operations, may determine, inter alia, the number of channels (columns) needed to perform read operations (e.g., determine the number of channels used to perform a read operation, stream time  $T_s$ , and so on). For example, a 4 kb data packet may be contained within 5 ECC codewords, including ECC codewords 3 through 7. Reading the 4 kb packet from the array 115 may, therefore, comprise reading data from two columns (columns 0 and 1). A larger 8 kb data structure may span ten ECC codewords (ECC codewords 98-107), and as such, reading the 8 kb data structure may comprise reading data from three columns of the array (columns 0, 1, and 2). Configuring the vertical stripes 646A-N with an increased depth may decrease the number of columns needed for a read operation, which may increase the stream time  $T_s$  for the individual read, but may allow for other independent read operations to be performed in parallel. Decreasing depth may increase the number of columns needed for read operations, which may decrease stream time  $T_s$ , but result in decreasing the number of other, independent read operations that can be performed in parallel.

[0164] FIG. 6H depicts embodiments of vertical stripes 607, each having a different respective depth. The vertical stripes 607 may comprise 1 kb, vertically aligned ECC codewords as disclosed above in conjunction with FIG. 6G. A 16 kb data structure 610 (packet) may be stored within a 4k deep vertical stripe 746. The data structure 610 may be contained within seventeen separate ECC codewords spanning five columns of the array 115 (columns 0 through 5). Accordingly, reading the data structure 610 may comprise reading data from an independent channel comprising six columns. The stream time  $T_s$  of the read operation may correspond to the depth of the vertical stripe 746A (e.g., the stream time of four ECC codewords).

[0165] The depth of the vertical stripe 746B may be increased to 8 kb, which may be sufficient to hold eight vertically aligned ECC codewords. The data structure 610 may be stored within seventeen ECC codewords, as disclosed above. However, the modified depth of the vertical stripe 746B may result in the data structure occupying three columns (columns 0 through 2) rather than six. Accordingly, reading the data structure 610 may comprise reading data from an independent channel comprising three columns, which may increase the number of other, independent read operations that can occur in parallel on other columns (e.g., columns 3 and 4). The stream time  $T_s$  of the read operation may double as compared to the stream time of the vertical stripe 746A.

[0166] FIG. 6I is a block diagram of another embodiment of a system 608 for adaptive data storage. In the FIG. 6I embodiment, the adaptive write module 248 may be configured to store data in a vertical stripe configuration within logical pages 542 of the solid-state storage array 115. The write module 240 may comprise one or more processing modules, which as disclosed above, may include, but are not limited to: a packet module 242, a whitening module 244, and an ECC write module 246. The ECC write module 246 may be configured to generate ECC codewords 620 (ECC codewords O through Z) in response to data for storage on the solid-state storage array 115, as disclosed above. The ECC codewords 620 may flow into the adaptive write module 248 serially via a 128 bit data path of the write module 240. As disclosed in further detail herein, the ECC write module 246 may further comprise a relational module 646 configured to include relational information in one or more of the ECC codewords 620.

[0167] The adaptive write module 248 may be configured to buffer the ECC codewords 620 for storage in vertical stripes, as disclosed herein. The adaptive write module 248 may comprise an adaptive fill module 660 that is configured to rotate the serial stream of ECC codewords 620 into vertical stripes by use of, inter alia, one or more cross point switches, FIFO buffers 662A-X, and the like. The FIFO buffers 662A-X may each correspond to a respective column of the array 115. The adaptive fill module 660 may be configured to rotate and/or buffer the ECC codewords 620 according to a particular vertical code word depth, which may be based on the ECC codeword 620 size and/or size of physical storage units of the array 115.

[0168] The adaptive write module 248 may be further configured to manage OOS conditions within the solid-state storage array 115. As disclosed above, a OOS condition may indicate that one or more columns 118 of the array are not currently in use to store data. The storage metadata 135 may identify columns 118 that are out of service within various portions (e.g., rows 117, logical erase blocks 540, or the like) of the solid-state storage array 115. In the FIG. 6I embodiment, the storage metadata 135 may indicate that column 2, of the current logical page 542, is out of service. In response, the adaptive fill module 660 may be configured to avoid column 2 by, inter alia, injecting padding data into the FIFO buffer of the OOS column (e.g., FIFO buffer 662C).

[0169] In some embodiments, the adaptive write module 248 may comprise a parity module 637 that is configured to generate parity data in accordance with the vertical stripe data configuration. The parity data may be generated horizontally, on a byte-by-byte basis within rows 117 of the array 115 as disclosed above. The parity data P0 may correspond to ECC codewords 0, 4, through 88; the parity data P1 may corre-

spond to ECC codewords **1**, **5**, through **89**, and so on. The adaptive write module **248** may include a parity control FIFO **662Y** configured to manage OOS conditions for parity calculations (e.g., ignore data within OOS columns for the purposes of the parity calculation).

[0170] The vertical stripe data configuration generated by the adaptive write module **248** (and parity module **637**) may flow to write buffers of the solid-state storage elements **116A-Y** within the array **115** through the write buffer and/or bank controller **252**, as disclosed above. In some embodiments, data rows **667** generated by the adaptive write module **247** may comprise one byte for each data column in the array **115** (columns **116A-X**). Each byte in a data row **667** may correspond to a respective ECC codeword **620** and may include a corresponding parity byte. Accordingly, each data row **667** may comprise horizontal byte-wise parity information from which any of the bytes within the row **667** may be reconstructed, as disclosed herein. A data row **667A** may comprise a byte of ECC codeword **0** for storage on column **0**, a byte of ECC codeword **4** for storage on column **1**, padding data for column **1**, a byte of ECC codeword **88** for storage on column **23**, and so on. The data row **667** may further comprise a parity byte **668A** for storage on column **24** (or other column), as disclosed above.

[0171] The data may be programmed unto the solid-state storage array **115** as a plurality of vertical stripes **646A-N** within a logical page **542**, as disclosed above (e.g., by programming the contents of program buffers to physical storage units of the solid-state storage elements **116A-Y** within the array **115**). In the FIG. 6I embodiment, the indexing  $S*N$  may correspond to vertical stripes configured to hold  $S$  ECC codewords in an array **115** comprising  $N$  columns for storing data.

[0172] As disclosed herein, data structures, such as data packets, may be stored within respective container data structures (ECC codewords), which may be spread across different columns **118** and/or rows **117** of the solid-state storage array **115**. FIG. 6J depicts one embodiment **609** of a solid-state storage array **115** comprising a data structure (packet **810C**) that is stored within a plurality of vertical stripes **846A-B**. As illustrated in FIG. 6G, the adaptive write module **248** may be configured to arrange ECC codewords comprising the data structure **810C**, such that portions of the data structure **810C** are stored within the vertical stripe **846A** and other portions are stored in a different vertical stripe **846B** (ECC codewords comprising the packet **810C** may wrap between different vertical stripes). In addition, portions of the data structure **810C** may be stored on different rows **117** of the array **115** (e.g., within different logical pages **542A** and **542B**). In some embodiments, data structure **810C** may span logical erase blocks and/or banks **119A-N**; the logical page **542A** may be within a different logical storage division **540** and/or different bank **119A-N** than the logical page **542B**. Moreover, header information stored with the data structures (e.g., headers **814A**, **814B**, and/or **814C**) may be stored in separate ECC codewords than other portions of the corresponding packets **812A**, **812B**, and/or **812C**.

[0173] In some embodiments, the ECC codewords comprising a particular data structure (e.g., data structure **810**) may comprise relational information, which may allow the storage module to verify that different ECC codewords read from various different portions of the array **115** correspond to the same data structure **810C**, despite the fact that the header information is distributed between different ECC codewords stored on different portions of the array **115**. Referring back to

FIG. 6I, the ECC write module **246** may comprise a relational module **646** configured to include relational information in the ECC codewords **620** generated thereby. The relational information may be configured to provide for identifying and/or verifying that certain ECC codewords **620** are related (e.g., provide for verifying that particular ECC codewords **620** comprise data of the same data structure **810C**). The relational information may comprise any identifying data. In some embodiments, the relational information may be derived from the header **814C** of the packet, such as the logical identifier(s) associated with the data structure **810C**. The relational information pertaining to data structures processed by the ECC write module **646** may, therefore, be determined based on storage metadata **135** associated with the data, header information, or the like.

[0174] The relational module **646** may be configured to mark the ECC codewords **620** with relational information in any suitable format and/or using any suitable mechanism. Marking may comprise adding information to the ECC codewords **620** (e.g., in one or more fields, etc.). In some embodiments, the relational module **646** may be configured to mark ECC codewords **620** through Steganography and/or watermarking. Watermarking may comprise performing an XOR operation between relational information (e.g., a bitmask of one or more logical identifier(s) associated with the corresponding data structure) and the ECC codewords **620**. As disclosed herein, an ECC datastructure **620** may comprise portions of multiple different data structures; such ECC codewords **620** may include relational information associated with each data structure contained therein. Accordingly, in some embodiments, the relational module **646** may be configured to mark an ECC codeword **620** with multiple instances of relational information (e.g., multiple watermarks).

[0175] FIG. 6K is a block diagram of another embodiment of a system **610** for adaptive data storage. The system **610** illustrates one embodiment of a read module **241** configured to read data stored in a vertical stripe configuration on a solid-state storage array **115**. The read module **241** may comprise an adaptive read module **247** configured to read data from rows of the array **115** (e.g., read data stored in vertical stripes **646A-N** within logical pages **542** of the array **115**). Data may be read into a read buffer **251** by use of the bus **127**, bank controller **252**, and/or log storage module **137**.

[0176] The adaptive read module **247** may comprise an adaptive strip module **661** configured to remove and/or avoid data of columns that are OOS (based on the storage metadata **135**, as disclosed above), which may comprise removing the data from an incoming data stream by use of a cross-point switch, or the like.

[0177] The read sequence module **663** may be configured to reorder and/or recombine ECC codewords **620** in sequence, which may comprise rotating vertical stripes read from the array **115** by use of respective buffers **665A-Y**, as disclosed above (e.g., rotating and combining ECC codewords read from respective columns **118** of the array **115**). The sequenced ECC codewords **620** may flow to other processing modules of the read module **241**.

[0178] In some embodiments, the ECC read module **245** may comprise a relational verification module **647** configured to verify relational information on the ECC codewords **620** (e.g., verify and/or authenticate one or more markings on the ECC codewords **620**). Verifying relational information may comprise performing an XOR operation between the ECC

codewords **620** and respective logical identifier(s) associated with the data structures contained therein. Verifying relational information of an ECC codeword **620** that comprises portions of multiple packets may comprise performing multiple XOR operations, each corresponding to logical identifier(s) of a packet contained therein. The logical identifier information used to perform relational verification may be received via the storage metadata **135** and/or as part of a read request. In some embodiments, requests to read data on the solid-state storage array **115** may be accompanied by the logical identifier(s) associated with the request, which may be translated into physical addresses by use of, inter alia, the storage metadata **135**. This logical identifier information may be used to perform relational verification on the corresponding ECC codewords **620**. The logical identifier(s) of other data structures within a particular ECC codeword **620** that are not part of the read request (if any) may be determined by use of, inter alia, a reverse index, or the like, of the storage metadata **135**.

[0179] If the relational verification module **647** fails to verify relational information of an ECC codeword **620**, the solid-state adaptive storage module **113** may issue an interrupt, indicating that the data could not be read. In response, the data reconstruction module **170** may attempt to acquire the data from another source and/or from another portion of the solid-state storage array **115**. In embodiments in which the relational module **645** watermarks ECC codewords **620** with logical identifier information, the relational verification module **647** may be configured to verify the relational information may performing an equivalent XOR operation. If the relational information differs between the XOR operation performed during storage and the XOR operation performed when the data is read, the corresponding ECC codeword(s) **620** may be corrupted, and the ECC read module **245** will detect uncorrectable errors there; in response, the storage module **130** may issue a read failure interrupt, as disclosed above.

[0180] FIG. 6L depicts one embodiment of data flow **611** of a read sequence operation. The data flow **611** depicted in FIG. 6L may be implemented by the adaptive read module **247** as disclosed herein. Referring to FIG. 6J, storage module **130** may receive requests to read data packets **810A**, **810B**, and **810C**. The read sequence module **663** and/or log storage module **137** may configure the adaptive storage module **113** to read data from the columns **118** comprising the requested data (by use of the logical-to-physical translation layer **132**). The adaptive storage module **113** may be configured to read the data packets **810A**, **810B**, and **810C** in a single read operation on the array **115**, which may comprise providing different addressing information to different sets of columns **118**. In the FIG. 6J embodiment, columns **0** and **1** may be configured to read data from logical page **542B**, column **2** may be configured to read data from logical page **542A**, columns **3** and **4** may be configured to read data from logical page **542N**, and columns **21-23** may be configured to read data from logical page **542A**. The different addressing information may be sent to the independent columns **118** via the bus **127**, as disclosed above.

[0181] The read operation may comprise transferring the contents of the specified logical pages into the read buffer **251**. FIG. 6L depicts one embodiment of a read buffer comprising data of packets **810A**, **810B**, and **810C**. Columns **0** through **23** of the of the buffer **251** may correspond to columns **118** of the array **115** and, as such, may comprise data

read from read buffers of the respective solid-state storage elements **116A-Y** comprising the array **115**. The contents of columns **5** through **20** are not shown in FIG. 6L to avoid obscuring the details of the depicted embodiment. These columns could, however, comprise data corresponding to other data structures, OOS mask data, or no-op data, read from the corresponding solid-state storage elements **116F-V**.

[0182] The read sequence module **663** may be configured to determine which portions of the buffer **251** comprise valid data (based on the logical-to-physical translation information, OOS metadata, and so on), and may reorder and/or mask the contents of the read buffer **251** to generate a sequence of ECC codewords **620** comprising the requested data. The read sequence module **663** may be further configured to order the data structures in accordance with an order of the request requests within, inter alia, the request buffer **136**. The ECC codeword sequence **622** may comprise an ordered sequence of ECC codewords **622A** comprising data structure **810A**, followed by the ECC codewords **622B** comprising data structure **810B**, and the ECC codewords **622C** comprising data structure **810C**. As illustrated in FIG. 6C, the contents of columns **0** and **1** of logical page **542B** (ECC sequence **622C-1**) may be ordered after the contents of columns **21-23** (ECC sequence **622C-2**) in the sequence **622**.

[0183] Referring back to FIG. 1, the storage module **130** may comprise a request buffer **136** configured to receive storage requests from one or more storage clients **104**. The storage requests may be queued in the request buffer **136**, and serviced and/or executed by the storage module **130**. In some embodiments, the storage module **130** comprises an adaptive schedule module **114** configured to determine an optimal schedule for storage operations based on, inter alia, the adaptive data configuration on the solid-state storage array **115**. As used herein, an "optimal" schedule refers to a schedule that maximizes an objective criteria. In some embodiments, the objective criteria may be maximization of parallelism while maintaining data ordering constraints and/or avoiding hazards, such as read before write, write before read, or the like.

[0184] FIG. 7 depicts one embodiment of adaptive scheduling performed by the adaptive schedule module **114**. The adaptive schedule module **114** may be configured to schedule storage operations in accordance with the adaptive configuration of data structures on a solid-state storage array **115**. As illustrated in FIG. 7, an ordered sequence of requests to read packets A, B, C, D, E, and F may be received at the storage module and buffered in the request buffer **136**. The adaptive schedule module **114** may be configured to analyze the requests in the buffer **136**, determine a layout of data corresponding to the requests on the solid-state storage array **115**, and to combine and/or schedule the requests to maximize read parallelism, while avoiding data hazards.

[0185] The adaptive schedule module **114** may determine that the read requests correspond to the data layout depicted in FIG. 7, by use of, inter alia, the logical-to-physical translation layer **132** and storage metadata **135**. The adaptive schedule module **114** may be further configured to identify column and/or channel conflicts between read requests, which may comprise identifying which read requests require use of columns that are needed by other read requests. As illustrated in FIG. 7, data packets **710A-F** stored within overlapping columns of the array **115** may be considered to conflict with respect to read scheduling. In the FIG. 7 embodiment data packets **710A** overlaps with (conflicts with) packet **710B**, packet **710B** overlaps with packet **710A** and **710C**, packet

710E overlaps with packet 710D and 710F, and so on. The adaptive schedule module 114 may identify channel conflicts by use of column bitmaps, or other technique. The adaptive schedule module 114 may be further configured to identify read requests that can be performed in parallel (e.g., read requests that do not conflict and/or require access to the same columns of the array 115). Non-conflicting read requests may be combined and/or aggregated into a single, composite read request. In the FIG. 7 embodiment, the requests to read packets A, C, E, and F may be combined into a single read operation 761. The requests to read packets B and D may be combined into another read operation 762. Data of the read operations 761 and 762 may be processed by the read module 241, which may comprise reordering, ECC decoding, dewhitening, and/or depacketizing the data, as disclosed herein. As illustrated in FIG. 7, the combined read requests may change the order of read operations (perform the read of packets C, E, and F before packet B). The adaptive schedule module 114 may be configured to combine, schedule and/or reorder operations to prevent data hazards, such as read-before-write and/or write-before-write. Alternatively, the adaptive schedule module 114 may be configured to maintain the order of the requests in the buffer 136, which may limit the degree of parallelism that can be achieved through request scheduling and aggregation.

[0186] As disclosed herein, errors within ECC codewords may be detected and/or corrected by the ECC read module 245 as data is read from the solid-state storage array 115. Some ECC codewords, however, may comprise more errors than can be corrected by the ECC algorithm. As disclosed above, in response to detecting an uncorrectable ECC codeword, the adaptive storage module 113 may issue an interrupt to the data recovery module 170, which may attempt to recover the data using, inter alia, parity data stored on the solid-state storage array. In some cases, uncorrectable errors may be caused by the failure of a portion of the solid-state storage array 115. Such errors may occur within specific columns, and as such, error conditions may result in losing the data of portions of a column 118 within the array 115.

[0187] FIG. 8 is a block diagram of one embodiment of a system 800 for reconstructing data stored on a failed column of a solid-state storage array 115 using, inter alia, parity substitution. Data of packet 910A may be read from the array 115 in a read operation. Data of the packet 910A may be stored within vertical stripe 946B. The read operation 961 may include reading other data packets 910B and 910C within other logical pages 946A and 946N. Data of the other packets 910B and 910C may not comprise uncorrectable errors, and may be processed through the read module 241, as disclosed above.

[0188] The ECC codewords in column 0 of the vertical stripe 946B, comprising data of packet 910A, may comprise errors that cannot be corrected by the ECC read module 245. In response, the adaptive storage module 113 may issue an interrupt to the data reconstruction module 170. The data reconstruction module 170 may be configured to determine the source of the uncorrectable error by use of the logical-to-physical translation layer 132, and to reconstruct data of column 0 in the vertical stripe 946B by use of, inter alia, other ECC codewords and/or the parity data stored within the vertical stripe 946B.

[0189] The data reconstruction module 170 may be configured to issue another read operation 962 to read the other ECC codewords 919 within the vertical stripe 946B. The read operation 962 may further comprise reading parity data 947B

of the vertical stripe 946B. The data acquired in the read operation 962 may be processed by the adaptive read module 248, which may comprise stripping padding data (if any) from the read buffer 251, as disclosed above. The ECC read module 245 may be configured to identify and/or correct errors in the ECC codewords 910A and 919, which may comprise decoding the ECC codewords 910A and 919 and/or generating corrected ECC codewords 920A and 929.

[0190] The data reconstruction module 170 may comprise a parity substitution module, which may be configured to reconstruct the ECC codewords 911A-N in column 0 by use of the corrected ECC codewords 920A-N corresponding to columns 1 through 10, corrected ECC codewords 929A-N corresponding to columns 11-23, and parity data 947A-N: ECC codeword 911A may be reconstructed by use of corrected ECC codewords 920A[1 through 10], corrected ECC codewords 929A[11 through 23], and parity data 947A, ECC codeword 911B may be reconstructed by use of corrected ECC codewords 920B[1 through 10], corrected ECC codewords 929B[11 through 23], and parity data 947B, and so on. As disclosed above, use of the corrected ECC codewords 919A-N and 929A-N may prevent error aggregation during parity substitution operations.

[0191] In some embodiments, parity substitution module 172 may be configured to perform a byte-wise parity substitution operation corresponding to the byte-wise parity generation embodiments disclosed in conjunction with FIGS. 6A-6F, 6I and 6K. Following reconstruction of the ECC codewords of column 0, data packet 910A may be processed by the read module 241 and returned to the requester, as disclosed herein, which may comprise discarding the other ECC codewords 919 and 929 read from the vertical stripe 946B.

[0192] FIG. 9 is a flow diagram of one embodiment of a method 900 for adaptive data storage. The method 900, and the other methods disclosed herein, may comprise steps configured for execution by a machine, such as a computing device 101, storage module 130, and/or adaptive storage module 113 as disclosed herein. Steps of the disclosed methods may be embodied as a computer program product, including a computer-readable storage medium comprising instructions configured for execution by a computing device to perform one or more method steps.

[0193] The method 900 may start and/or be initialized, which may comprise initializing communication resources, loading computer-executable instructions, and so on.

[0194] Step 920 may comprise arranging data for storage on a solid-state storage array 115. The solid-state storage array 115 may comprise a plurality of independent columns 118 (e.g., solid-state storage elements 116A-Y), which may be communicatively coupled to an adaptive storage module 113 in parallel by, inter alia, a bus 127.

[0195] In some embodiments step 920 may further comprise generating data structures for storage on the array 115. Step 920 may comprise generating one or more packets 310 comprising data for storage on the array 115, by use of a packet module 242. The packets 310 may comprise contextual metadata pertaining to the data, such as one or more logical identifiers associated with the data, and so on, as disclosed above. Step 920 may further comprise whitening the data packets, by use of a whitening module 244. Step 920 may comprise generating one or more ECC codewords comprising the packets. The ECC codewords may comprise ECC codewords, ECC symbols, or the like. In some embodiments, step 920 further comprises including

relational information in the ECC codewords, which may comprise watermarking the ECC codewords within a bitmask (or other data) derived from a logical identifier associated with the data packets.

[0196] Arranging the data at step 920 may comprise buffering one or more data structures, such that the data structures layout within portions of the solid-state storage array 115. Arranging the data structures at step 920 may, therefore, comprise configuring the data structures to layout in a horizontal, vertical, and/or hybrid configuration within the solid-state storage array 115. Step 820 may comprise a 24 byte by 10 byte buffer of the horizontal embodiment of FIG. 6A. Alternatively, step 920 may comprise arranging the data structures for a vertical data structure layout, as disclosed in conjunction with FIG. 6C; step 920 may comprise using a buffer capable of buffering 24 240 byte ECC codewords 620 (or other data structures) for storage on respective columns of the logical storage element. Step 920 may further comprise arranging the data structures in a hybrid, independent channel configuration as disclosed in conjunction with FIG. 6E; step 920 may comprise buffering data structures in a write buffer capable of buffering 24/N 240 byte ECC codewords 620 data structures where N is the number of independent columns of the hybrid storage arrangement. The data structures may comprise ECC codewords 620. The arrangement of step 920 may comprise configuring data of the same ECC codeword for storage on two or more different independent columns 118 of the array 115. Alternatively, the arrangement of step 920 may comprise configuring data of the ECC codewords for storage within respective columns 118 of the array 115.

[0197] Alternatively, or in addition, buffering the data structures at step 920 may comprise configuring the data structures to layout within vertical stripes of the solid-state storage array 115. Step 920 may comprise buffering the data in accordance with a selected vertical stripe depth and/or length, which may correspond to an integral factor of data structures and/or page size of the solid-state storage medium 110. Step 920 may, therefore, comprise streaming ECC codewords 620 into vertical FIFO buffers 662A-X as disclosed in conjunction with FIG. 6I. The vertical stripe configuration may comprise storing ECC codewords 620 within respective columns 118 of the array 115. However, data structures contained within the ECC codewords 620 (e.g., packets) may be configured for storage on two or more different columns 118.

[0198] In some embodiments, step 920 further comprises adapting the data layout to avoid portions of the array 115 that are out of service. Step 920 may comprise injecting padding data into the buffer(s) to mask 00S columns 118 of the array (in accordance with the storage metadata 135), as disclosed above.

[0199] Step 930 may comprise streaming the data arranged at step 920 to the solid-state storage array 115, as disclosed above. Step 830 may comprise byte-wise streaming bytes to program buffers of a plurality of independent columns 118 of the array 115. Step 930 may further comprise generating byte-wise parity information for storage on a parity column of the array 115, as disclosed above.

[0200] Step 940 may comprise programming the contents of the program buffers streamed at step 930 onto a logical page of the solid-state storage array 115. Step 940 may comprise issuing a program command to the solid-state storage array 115 via the bus 127. In response to the command, each of the plurality of independent columns 118 of the array may be configured to perform a program operation concurrently

and/or in parallel with other columns 118 within the array 115. Steps 920-940 may further comprise updating the logical-to-physical translation layer 132 to indicate the physical storage locations of the data structures stored on the array 115. The physical storage locations may indicate the bank 119A-N, array 115A-N, logical page 542, offset, and the like, of the data structures. The logical-to-physical translation metadata may comprise any-to-any associations between logical addresses, such as logical identifiers, and addresses of physical storage locations within the array 115.

[0201] FIG. 10 is a flow diagram of another embodiment of a method 1000 for adaptive data storage. The method 1000 may start and/or be initialized as disclosed above.

[0202] Step 1010 may comprise determining an adaptive data arrangement for use within a solid-state storage array 115. The determination of step 1010 may be based on, inter alia, a read time  $T_r$  of the solid-state storage medium 110, a stream time  $T_s$  of the adaptive storage module 113, data access characteristics of storage clients 104, desired IOPS characteristics, data reconstruction characteristics, and so on. The determination of step 1010 may comprise selecting between one or more of: a) a horizontal data arrangement that reduces stream time  $T_r$ , but reduces availability of read-parallelism, b) a vertical data arrangement that increases read-parallelism, but may increase stream time  $T_r$ , c) a hybrid, independent channel configuration, and/or d) a vertical stripe configuration having a particular vertical stripe depth.

[0203] Step 1010 may comprise generating a profile of data storage operations by, inter alia, the adaptive storage profiling module 160. As used herein, profiling data operations refers to gathering information (e.g., storage metadata 135) pertaining to the storage operations performed by storage clients 104 through the storage interface 131. Profiling data may comprise data access patterns, characteristics of the solid-state storage medium 110, bus 127, and so on, which may be used to determine an optimal adaptive data structure layout on the solid-state storage array 115. The adaptive storage profiling module 160 may be configured to gather such profiling information and/or generate recommendations regarding data layout in response to the profiling information. For example, applications that exhibit a large number of data accesses to relatively small data segments and/or packets, may be suited to a vertical configuration, a hybrid, independent channel configuration (e.g., 2 or 4 column channel configuration), and/or a vertical stripe configuration. In another example, the storage medium 110 may exhibit relatively high stream times as compared to read times  $T_r$ , and as such, a horizontal and/or wide channel configuration may result in improved performance.

[0204] The determination of step 1010 may be based on data reconstruction characteristics of various adaptive data layouts. Over time, the solid-state storage medium 110 may become less reliable and, as such, data structure configuration that provides better data reconstruction performance may be preferred over other configurations. For example, highly vertical configurations, including the vertical stripe configurations, may reduce error aggregation during parity reconstruction operations as compared to horizontal data layouts and, as such, may provide improved data reconstruction performance.

[0205] In some embodiments, step 1010 may comprise determining an adaptive data layout by use of an objective function. The objective function may be configured to quantify the performance of different adaptive data layout con-

figurations in view of the profiling data gathered by the adaptive storage profiling module 160 and/or other considerations (e.g., data reconstruction characteristics). The adaptive data configuration that provides the highest utility per the objective function may be identified as the optimal data configuration for the particular set of profiling data and/or other considerations.

[0206] Step 1010 may further comprise automatically configuring the storage module 130 to implement the determined adaptive data arrangement. Alternatively, step 1010 may comprise providing information pertaining to the determined adaptive data arrangement to a user, administrator, or other entity, which may determine whether any changes should be implemented.

[0207] Steps 1020, 1030, and 1040 may comprise arranging data for storage on the solid-state storage array in accordance with the determined, adaptive data arrangement, streaming the data structures to the array 115, and programming the data to the array 115, as disclosed above.

[0208] FIG. 11 is a flow diagram of another embodiment of a method 1100 for adaptive data storage. Step 1120 may comprise determining the storage location of requested data within the array 115. Step 1120 may comprise determining the storage location by use of a logical-to-physical translation layer 132, which may include storage metadata 135, such as a forward index, map, or the like. The storage location may indicate an adaptive layout configuration of the data structure on the array 115 which, as disclosed herein, may include, but is not limited to: a horizontal configuration, a vertical configuration, a hybrid, independent channel configuration, a vertical stripe configuration, or the like.

[0209] Step 1130 may comprise reading the data from the determined storage locations and/or in accordance with the determined data structure configuration. The read operation may comprise reading data from one or more independent columns 118 comprising the array 115 (e.g., reading data from one or more solid-state storage elements 116A-Y), as disclosed herein. Step 1130 may comprise providing columns 118 of the array 115 with respective physical addresses (as determined at step 1120). The physical address may be the same (or equivalent) for each of the solid-state storage elements 116A-Y (e.g., in a horizontal data arrangement). Alternatively, the physical addresses may differ (e.g., for a vertical, hybrid, independent channel, and/or certain vertical stripe configurations). Step 1130 may incur a read latency  $T_r$ , as described above.

[0210] Step 1130 may further comprise streaming the ECC codewords from read buffer(s) of the array into a adaptive storage module 113. Streaming the data structures may comprise streaming sufficient data to reconstruct a data structure, such as a plurality of ECC codewords 620 comprising one or more packets comprising the requested data. Each cycle of the bus 127 may be configured to transfer a single byte from each column 118 of the array. The number of bus cycles needed to transfer the requested ECC codewords may depend on the arrangement of the data: data arranged horizontally may require ten (10) cycles to transfer a 240 byte ECC codeword from 24 columns 118; data arranged vertically may require two hundred forty (240) cycles to transfer the same 240 byte ECC codeword from a single column 118; data arranged in a hybrid, independent channel arrangement may require  $240/N$  cycles, where  $N$  is the number of independent, horizontal columns in the arrangement; and data arranged in vertical stripes may require 240 cycles. In the vertical, hybrid,

independent channel, and vertical stripe configurations, however, multiple ECC codewords may be streamed concurrently.

[0211] Step 1140 may comprise reconstructing the requested data by use of the adaptive storage module 130 (e.g., an adaptive read module 247). Step 1140 may comprise buffering data read from the array 115, reordering the data, stripping padding data corresponding to OOS columns 118 (if any), and so on as disclosed herein. Step 1140 may further comprise performing ECC error detection and/or on ECC codewords comprising the data packet, by use of the ECC read module 245. ECC processing may further comprise verifying relational information associated with the ECC codewords, such as a watermark on the ECC codewords, which may be derived from one or more logical identifiers associated with the requested data. Step 1140 may further comprise dewhitening the data packets, by use of the dewhite module 243 and depacketizing the data by use of the depacket module 241, as disclosed herein.

[0212] FIG. 12 is a flow diagram of another embodiment of a method 1200 for adaptive request scheduling. Step 1210 may comprise buffering storage requests within a request buffer 136 of the storage module 130. The requests may be ordered within the buffer 136.

[0213] Step 1220 may comprise determining storage location(s) corresponding to the requests within the array 115, as disclosed above.

[0214] Step 1222 may comprise identifying storage requests that can be executed concurrently (e.g., do not conflict). As disclosed above, a storage request conflict refers to storage requests that cannot be performed concurrently within the same bank 119 and/or array 115. A storage request conflict may result from data structures associated with the requests overlapping within the array 115, such that the storage requests pertain to data stored within one or more of the same columns 118 within the array 115. Storage requests that can be executed concurrently may refer to storage requests that pertain to data stored on different independent columns 118 of the array 115.

[0215] Step 1224 may comprise scheduling and/or combining the requests in accordance with the concurrencies and/or conflicts identified at step 1222. Step 1224 may comprise combining requests that can be performed concurrently (e.g., do not conflict). Combining requests may comprise reordering requests within the buffer (e.g., changing the order of the requests within the buffer 136), as disclosed above, in order to combine concurrent requests and/or avoid request conflicts. Accordingly, step 1224 may comprise determining that the scheduled storage requests and/or storage request combinations do not create data hazards, such as read-before-write hazards, write-before-read hazards, or the like. In some embodiments, step 1224 may be limited to combining requests without changing request ordering, to ensure that data hazards do not occur.

[0216] Step 1230 may comprise performing the scheduled requests, which may comprise performing one or more combined read operations, as disclosed herein. Step 1240 may comprise reconstructing data of the requests by use of a read module 241, adaptive read module 247, and so on, as disclosed herein.

[0217] FIG. 13 is a flow diagram of one embodiment of a method 1300 for adaptive data reconstruction. Step 1320 may comprise detecting an uncorrectable error in an ECC codeword. Step 1320 may comprise detecting the error by use of

an ECC read module **245** of the read module **241**. Step **1320** may further comprise issuing an interrupt to a data reconstruction module **170**, as disclosed herein. In some embodiments, step **1320** further comprises determining the source of the uncorrectable error, which may include identifying the column **118** (e.g., particular solid-state storage element **116A-Y**) from which the uncorrectable data was read. Determining the source of the error may comprise referencing storage metadata **135**, such as the logical-to-physical translation between the data and physical storage location. Alternatively, identifying the source of the error may comprise iterative parity substitution, as disclosed above.

[0218] Step **1330** may comprise performing a read operation to read ECC codewords within the same vertical stripe as the uncorrectable error, as disclosed above in conjunction with FIG. **8**. Alternatively, step **1330** may comprise performing a read operation to read ECC codewords within other columns **118** of a vertical data configuration and/or within other channels of a hybrid, independent channel configuration. Step **1330** may further comprise reading parity data corresponding to the vertical stripe, vertical data configuration, and/or hybrid, independent channel configuration, as disclosed herein.

[0219] Step **1340** may comprise correcting ECC codewords in the vertical stripe and/or other columns **118**. Correcting the ECC codewords may comprise processing the ECC codewords using the ECC read module **245** and/or relational verification module **647**, as disclosed above. In some embodiments, step **1340** may be omitted, and the reconstruction step **1350** may proceed without first decoding and/or correcting the ECC codewords of the other columns **118**.

[0220] Step **1350** may comprise reconstructing the uncorrectable data by use of the corrected ECC codewords and parity data. Step **1350** may comprise a byte-wise parity substitution operation between the corrected ECC codewords and the parity data. In hybrid, independent channel configurations, step **1350** may further comprise determining the source of the uncorrectable error using iterative parity substitution within the independent channel comprising the uncorrectable error. In a two-channel configuration, iterative parity substitution may comprise determining which of the two channels is the source of the error. Other hybrid, independent channel configurations may involve additional iterations, in accordance with the width of the channels.

[0221] Step **1350** may further comprise reconstructing the data by, inter alia, decoding the ECC codewords, including the reconstructed ECC codewords, dewhitening, and depacketizing the data, as disclosed above.

[0222] FIG. **14** is a flow diagram of one embodiment of a method **1400** for determining an adaptive storage configuration. Step **1420** may comprise acquiring profiling data **1420**. Step **1420** may comprise accessing profiling data generated by the storage module **130**, stored, in a log storage format, on the solid-state storage medium **110**, and/or the like. The profiling data may include an ordered history of storage operations and/or requests received at the storage module **130**.

[0223] Step **1430** may comprise determining performance metrics of one of more adaptive data storage configurations. Step **1430** may comprise replaying and/or simulating the history of storage requests in one or more different adaptive storage configurations, which may include, but are not limited to: a horizontal configuration, a vertical configuration, a hybrid, independent channel configuration, a vertical stripe configuration (of various vertical stripe depths), and/or the

like. Step **1430** may comprise determining the simulating the contents of various portions of the solid-state storage array **115** under the different adaptive data configurations, scheduling read operations according to the adaptive layout (using the adaptive schedule module **114**), and/or the like. The performance metrics may be based on one or more of a desired IOPS metric, a read time  $T_s$ , a stream time  $T_s$ , and so on, as disclosed above.

[0224] Step **1440** may comprise determining an adaptive storage configuration. Step **1440** may comprise determining an optimal adaptive storage configuration based on the performance metrics and/or one or more objective functions. The determination of step **1440** may include various metrics and/or considerations, including the performance metrics calculated at step **1430**, data reconstruction characteristics of various data layout configurations, and so on. Step **1440** may further comprise providing an indication of the determined storage configuration (to a user, administrator, or other entity), automatically configuring the adaptive storage module **113** to operate in accordance with the determined adaptive storage configuration, and/or the like.

[0225] The above description provides numerous specific details for a thorough understanding of the embodiments described herein. However, those of skill in the art will recognize that one or more of the specific details may be omitted, or other methods, components, or materials may be used. In some cases, operations are not shown or described in detail.

[0226] Furthermore, the described features, operations, or characteristics may be combined in any suitable manner in one or more embodiments. It will also be readily understood that the order of the steps or actions of the methods described in connection with the embodiments disclosed may be changed as would be apparent to those skilled in the art. Thus, any order in the drawings or Detailed Description is for illustrative purposes only and is not meant to imply a required order, unless specified to require an order.

[0227] Embodiments may include various steps, which may be embodied in machine-executable instructions to be executed by a general-purpose or special-purpose computer (or other electronic device). Alternatively, the steps may be performed by hardware components that include specific logic for performing the steps, or by a combination of hardware, software, and/or firmware.

[0228] Embodiments may also be provided as a computer program product including a computer-readable storage medium having stored instructions thereon that may be used to program a computer (or other electronic device) to perform processes described herein. The computer-readable storage medium may include, but is not limited to: hard drives, floppy diskettes, optical disks, CD-ROMs, DVD-ROMs, ROMs, RAMs, EPROMs, EEPROMs, magnetic or optical cards, solid-state memory devices, or other types of medium/machine-readable medium suitable for storing electronic instructions.

[0229] As used herein, a software module or component may include any type of computer instruction or computer executable code located within a memory device and/or computer-readable storage medium. A software module may, for instance, comprise one or more physical or logical blocks of computer instructions, which may be organized as a routine, program, object, component, data structure, etc., that perform one or more tasks or implements particular abstract data types.

**[0230]** In certain embodiments, a particular software module may comprise disparate instructions stored in different locations of a memory device, which together implement the described functionality of the module. Indeed, a module may comprise a single instruction or many instructions, and may be distributed over several different code segments, among different programs, and across several memory devices. Some embodiments may be practiced in a distributed computing environment where tasks are performed by a remote processing device linked through a communications network. In a distributed computing environment, software modules may be located in local and/or remote memory storage devices. In addition, data being tied or rendered together in a database record may be resident in the same memory device, or across several memory devices, and may be linked together in fields of a record in a database across a network.

**[0231]** It will be understood by those having skill in the art that many changes may be made to the details of the above-described embodiments without departing from the underlying principles of the disclosure.

We claim:

1. A method, comprising:
  - managing storage operations on a plurality of solid-state storage elements;
  - generating an ECC codeword comprising data for storage on the solid-state storage elements; and
  - storing portions of the ECC codeword on two or more of the solid-state storage elements.
2. The method of claim 1, further comprising:
  - generating a first set of ECC codewords comprising data of a first storage request;
  - generating a second set of ECC codewords comprising data of a second storage request;
  - storing the first set of ECC codewords in a first set of one or more solid-state storage elements; and
  - storing second set of ECC codewords in a second, different set of one or more solid-state storage elements.
3. The method of claim 2, further comprising reading ECC codewords comprising the data of the first storage request from the first set of solid-state storage elements and ECC codewords comprising the data of the second storage request from the second set of solid-state storage elements in a single read operation.
4. The method of claim 1, further comprising:
  - dividing the plurality of solid-state storage elements into a plurality of independent channels, each independent channel comprising a respective subset of solid-state storage elements; and
  - storing ECC codewords corresponding to respective storage requests within respective independent channels.
5. The method of claim 4, further comprising determining an optimal independent channel configuration based on one or more of a read time of the solid-state storage elements, a stream time of ECC codewords, and profiling data pertaining to storage operations performed by the storage module.
6. The method of claim 1, further comprising:
  - marking the ECC codeword with relational information derived from a logical identifier corresponding to the data of the ECC codeword; and
  - validating the mark.
7. An apparatus, comprising:

a storage module configured to manage storage operations on a solid-state storage array comprising a plurality of columns, each column comprising a respective solid-state storage element;

an error-correcting code (ECC) write module configured to generate ECC codewords comprising data segments for storage on the solid-state storage array; and

an adaptive write module configured to format the ECC codewords into vertical stripes, wherein the vertical stripes are configured to arrange data of the ECC codewords within respective columns of the solid-state storage array, and wherein two or more ECC codewords comprising one of the data segments are stored within two or more different columns of the solid-state storage array.

8. The apparatus of claim 7, further comprising an adaptive read module configured to identify two or more columns comprising ECC codewords comprising a requested data segment, and to read the ECC codewords comprising the requested data segment from the two or more columns in parallel.

9. The apparatus of claim 8, further comprising a read sequence module configured to reorder the ECC codewords in accordance with an order of the requested data segment and a vertical stripe arrangement of the ECC codewords within the solid-state storage array.

10. The apparatus of claim 7, further comprising an adaptive schedule module configured to combine two or more read operations into a combined read operation, the two or more read operations corresponding to ECC codewords stored within different sets of columns of the solid-state storage array.

11. The apparatus of claim 10, further comprising an ordered queue of storage requests, wherein the adaptive schedule module is configured to combine two or more read operations within the ordered queue into the combined read operation, wherein combining the two or more storage requests comprises modifying an order of the storage requests within the ordered queue.

12. The apparatus of claim 10, wherein the combined read operation comprises providing different addressing information to the different sets of columns of the solid-state storage array.

13. The apparatus of claim 7, further comprising:

an ECC read module configured to detect an uncorrectable ECC codeword in response to a first read operation; and  
 a data recovery module configured to recover the uncorrectable ECC codeword by reading other ECC codewords within the vertical stripe with the uncorrectable ECC codeword in a second read operation, decoding the other ECC codewords, and reconstructing the uncorrectable ECC codeword using the decoded ECC codewords and parity data of the vertical stripe.

14-29. (canceled)

30. A system, comprising:

means for generating ECC codewords comprising data segments for storage on one or more solid-state storage elements, wherein each solid-state storage elements are communicatively coupled to a storage controller by a bus;

means for arranging the ECC codewords for storage in a vertical stripe configuration, wherein the vertical stripe configuration comprises arranging each ECC codeword for storage within a respective one of the solid-state

storage elements, and wherein ECC codewords comprising a data segment are arranged for storage on two or more different solid-state storage elements; and means for storing the arranged ECC codewords on the solid-state storage elements.

**31.** The system of claim **30**, wherein the vertical stripe configuration comprises arranging ECC codewords within the solid-state storage elements at a vertical stripe depth, wherein the vertical stripe depth is less than a page size of the solid-state storage elements and is an integral factor of a size of the ECC codewords.

**32.** The system of claim **30**, wherein the means for arranging the ECC codewords for storage in the vertical stripe configuration comprises:

means for streaming data rows of the arranged ECC codewords to respective program buffers of the solid-state storage array; and

means for calculating parity data corresponding to each of the data rows.

**33.** The system of claim **32**, further comprising means for reconstructing a corrupt ECC codeword, comprising:

means for reading one or more other ECC codewords stored within a vertical stripe comprising the corrupt ECC codeword;

means for correcting the one or more other ECC codewords; and

means for reconstructing the corrupt ECC codeword using the corrected one or more other ECC codewords and parity data corresponding to data rows of the vertical stripe.

**34.** The system of claim **30**, further comprising means for adaptive scheduling, comprising:

means for identifying respective sets of one or more solid-state storage elements comprising data of each of a plurality of queued read requests; and

means for determining a read operation configured to perform two or more of the queued read requests in a single read operation on the plurality of solid-state storage elements.

\* \* \* \* \*