

Peak–Power Reduction in OFDM without Explicit Side Information

Marco Breiling, Stefan H. Müller–Weinfurter, and Johannes B. Huber

Abstract— We propose a novel method for reducing the peak–to–average power ratio (PAR) of the transmit signal before the power amplifier in the transmitter. The method is based on the Selected Mapping (SLM) approach of [1]; in contrast to other schemes, SLM represents a method to efficiently reduce the PAR without introducing additional distortion in the transmit signal. This is accomplished by generating a set of candidate transmit signals, all representing the same information sequence. The candidate signals are then examined, and only the most favourable candidate in terms of the peak–power is transmitted. The proposed novel scheme elegantly solves an open problem with SLM, namely that the receiver needs highly reliable information about the transmitter’s choice of the candidate. Our method refrains from transmitting this side information explicitly. It requires some additional complexity in the transmitter, whereas the additional cost in the receiver is almost vanishing. Besides for OFDM, the proposed method is applicable for any digital transmission scheme.

Keywords—Peak–Power Reduction, PAR, SLM, Out–of–Band Power

I. INTRODUCTION

A problem arising in any transmitter are non–linearities of the power amplifier which result in out–of–band radiation, when the transmit signal at the amplifier’s input has large amplitudes. This problem is particularly severe in the case of OFDM, since here the transmit signal exhibits a rather high PAR. Furthermore, non–linear amplification of large signal peaks causes intermodulation among the OFDM subcarriers. Conventional solutions to this problem are either to provide a large back–off in the amplifiers, which results in an inefficient amplification, or by employing expensive amplifiers being nearly linear for a larger input range. Several methods have been proposed to overcome the depicted problem by reducing the PAR, most of them tackling this task by introducing distortion in the transmit signal.

The scheme proposed in this paper is based on the SLM scheme of [1], [2] for reducing the PAR without distorting the transmit signal. SLM schemes generate a whole set of candidate signals representing the same information, and then choose and transmit the most favourable signal as regards to the PAR. In conventional SLM schemes, side information about this choice needs to be explicitly transmitted along with the chosen candidate signal. If the side information about the transmitter’s choice is received in error, then the information in the transmitted candidate signal cannot be recovered in the receiver and is completely lost. Therefore, the side information needs a particularly strong protection against transmission errors.

In our extension of SLM [3], the explicit transmission of particularly protected side information can be avoided by introducing only little additional redundancy into the transmit-

ted signal. Our approach is flexible in that it does neither require a specific channel code nor a particular modulation format. It works fine for any digital transmission scheme, however its advantages are most impressive, when there is a high PAR to reduce. Therefore, we concentrate on the case of (coded or uncoded) OFDM transmission in this paper.

The paper is organized as follows: Section II provides a short review of the assumed OFDM scheme. In Section III, we give an introduction to SLM, and we propose our extended SLM scheme. In Section IV, simulation results for the bit error rates, amplitude characteristics, and the power spectral density of the amplified transmit signal are presented for an exemplary OFDM transmission scheme.

II. OFDM SYSTEM MODEL

OFDM utilizes D_u (used) “orthogonal” subcarriers with uniform frequency spacing. Frequency multiplexing is implemented by D –point inverse discrete Fourier transform (IDFT) ($D \geq D_u$) in the transmitter. Binary data is mapped onto D_u subcarrier amplitudes A_ν , with $0 \leq \nu < D$ being the subcarrier index. Here, all D_u active subcarriers use the same signal set \mathcal{A} , but the proposed scheme also works for mixed signal constellations. Inactive (so–called virtual) subcarriers are set to zero to shape the transmit signal’s power spectral density (PSD).

The subcarrier vector $\mathbf{A} = [A_0, \dots, A_{D-1}]$ with all subcarrier amplitudes of the current OFDM symbol interval is transformed by IDFT to obtain the transmit sequence $\mathbf{a} = [a_0, \dots, a_{D-1}] = \text{IDFT}\{\mathbf{A}\}$. The samples a_κ are transmitted by ordinary T –spaced pulse amplitude modulation. A guard interval is not considered here as it does not affect the PAR. The receiver performs the DFT to obtain the received subcarrier amplitudes $\mathbf{Y} = [Y_0, \dots, Y_{D-1}] = \text{DFT}\{\mathbf{y}\}$ from the received samples y_κ .

III. EXTENDING THE SELECTED MAPPING (SLM) SCHEME

A. Introduction to Selected Mapping (SLM)

In SLM [1], [2] (and related [4], [5]), it is assumed that U statistically independent alternative transmit sequences $\mathbf{a}^{(u)}$, $0 \leq u < U$, which represent the same information are generated by some suitable algorithm. Finally, the sequence $\mathbf{a}^{(\tilde{u})}$ with lowest peak power is selected for transmission.

To perform the appropriate inverse operation, the SLM receiver requires knowledge about transmit sequence selection in the current OFDM symbol period. Thus, the number \tilde{u} needs to be transmitted to the receiver unambiguously. Obviously, $\lceil \log_2 U \rceil$ bits are required to represent this side information, which is of highest importance to recover the data.

The authors are with Lehrstuhl für Nachrichtentechnik II, Universität Erlangen–Nürnberg, Cauerstraße 7/NT, D–91058 Erlangen, Germany, Phone: +49 / 9131 / 8527668, Fax: +49 / 9131 / 8528919, e–mail: breiling@LNT.de, http://www.LNT.de/LNT2

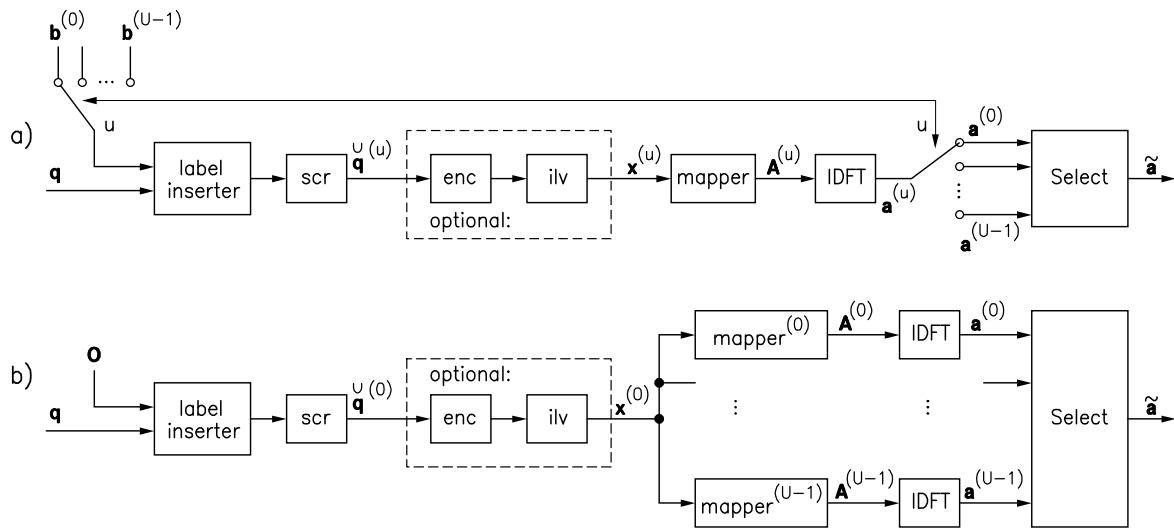

Fig. 1. OFDM transmitter incorporating the extended SLM scheme with a scrambler.

B. SLM with Scrambling

We propose a scrambling scheme, which abstains from explicit transmission and careful protection of side information. Fig. 1a displays a block diagram of the transmitter. To generate U different transmit sequences $\mathbf{a}^{(u)}$, $0 \leq u < U$, representing the same binary information word \mathbf{q} , labels $\mathbf{b}^{(u)}$ are inserted as a prefix to \mathbf{q} . The labels are U different binary vectors of length $\lceil \log_2 U \rceil$, and we assume in this paper without loss of generality that $\mathbf{b}^{(0)} = \mathbf{0}$. The concatenated vector $\bar{\mathbf{q}}^{(u)}$ of the label prefix and the information word is then fed into a scrambler consisting of a shift-register with a feedback branch only as shown in Fig. 2, which is reset to the zero-state before the scrambling takes place. The labels are hence used to drive the scrambler into one of U different states before scrambling the information word \mathbf{q} itself. The scrambled output vector $\check{\mathbf{q}}^{(u)}$ is then processed as usual, i.e., in our example, it is channel encoded, bitwise interleaved, and mapped to a signal constellation. After the IDFT, we obtain the transmit sequence $\mathbf{a}^{(u)}$ associated with the inserted label $\mathbf{b}^{(u)}$. This proceeding is executed for $u = 0, \dots, U-1$, and finally the specific number \tilde{u} is selected, such that the transmitted sequence $\tilde{\mathbf{a}} = \mathbf{a}^{(\tilde{u})}$ is that with the lowest peak-power of all candidates.

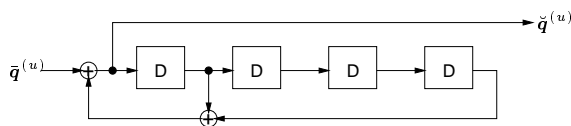

Fig. 2. A scrambler of memory 4 with feedback polynomial $1 + x + x^4$

The transmitter scheme shown in Fig. 1b is equivalent to the above scheme. The linearity (in $\text{GF}(2)$) of the label inserter, the scrambler, the channel encoder, and the interleaver can be exploited by processing the label vectors $\mathbf{b}^{(u)}$ and the information word \mathbf{q} separately in these stages. Only a single interleaved codeword $\mathbf{x}^{(0)}$ needs to be generated, which is obtained from concatenating only the zero-label

$\mathbf{b}^{(0)} = \mathbf{0}$ with \mathbf{q} in the label inserter. Owing to the aforementioned linearity (in $\text{GF}(2)$), the U different subcarrier vectors $\mathbf{A}^{(u)}$, $u = 0, \dots, U-1$ can then be generated by applying U different vector mappings to $\mathbf{x}^{(0)}$. Observe that the u -th vector mapping needs to be calculated only once from the associated label $\mathbf{b}^{(u)}$ and can be stored in a read-only memory, and that the mapping may be different for each element of the input vector $\mathbf{x}^{(0)}$. These U parallel mappings are followed by IDFTs and the selection of the most favourable transmit sequence $\tilde{\mathbf{a}}$ as exhibited above. From this second scheme of Fig. 1b, we clearly see the relationship to the SLM algorithm in [1].

If the period length¹ of the scrambler is $\geq U-1$, then the U subcarrier vectors $\mathbf{A}^{(u)}$ are usually satisfyingly different from each other, such that they appear to be generated statistically independent from each other. Starting a scrambler in one of $U-1$ different non-zero states before scrambling \mathbf{q} results in a $\check{\mathbf{q}}^{(u)}$, which is the sum of $\check{\mathbf{q}}^{(0)}$ and one out of $U-1$ pseudo-noise sequences. Additionally, the interleaver and the non-linear (in $\text{GF}(2)$) mapper boost this pseudo-randomness effect of the mappings from \mathbf{q} to $\mathbf{A}^{(u)}$, which is the essential ingredient of SLM schemes.

The corresponding receiver is depicted in Fig. 3. The received sample vector \mathbf{y} is processed as in ordinary OFDM systems, i.e. DFT, demapped (or detected), deinterleaved, and decoded. The only additional devices are a descrambler and a label dumper. The descrambler performs the inverse operation to the scrambler in the transmitter and is hence a shift-register with a feedforward branch, only, as shown in Fig. 4. The descrambler is reset to the zero-state before descrambling starts for an OFDM symbol. In the Figure, $\hat{\mathbf{q}}$ represents the estimated concatenated vector of the label prefix and the information word, and $\check{\hat{\mathbf{q}}}$ is this vector before descrambling (or equivalently: after scrambling). If no transmission errors have occurred, the output $\hat{\mathbf{q}}$ of the descrambler is the concate-

¹A maximum scrambler period is obtained, if the feedback polynomial of the scrambler is primitive in $\text{GF}(2)$ [6].

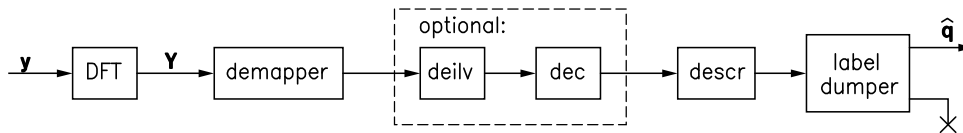
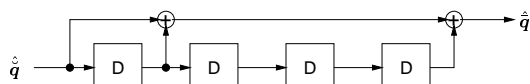

Fig. 3. Corresponding OFDM receiver for the extended SLM scheme.

nation of the transmitted $b^{(\tilde{u})}$ and q . The label dumper only needs to strip off the label prefix and output the estimated information word \hat{q} . We see that the receiver can explicitly determine the number \tilde{u} of the sequence selected for transmission, but it does not need this information for data recovery. If errors occur during transmission, the descrambler causes a moderate multiplication of these errors. As an example, consider the case that the transmitted binary vector is the all zero-word $\check{q}^{(\tilde{u})} = \mathbf{0}$. A single binary one in \hat{q} then represents a transmission error which generates a number of errors in the descrambled vector \hat{q} as large as the weight of the scrambler polynomial. Therefore, a scrambler polynomial of low weight should be chosen. However, transmission errors usually occur in bursts — particularly at the output of a convolutional decoder. Multiple errors inside the descrambler can partially cancel each other out at the descrambler's output. Hence, the multiplication of errors caused by the descrambler is in practice less than the weight of the polynomial.

Fig. 4. The descrambler for the scrambler polynomial $1 + x + x^4$.

In the case that the channel code is a convolutional code, the scrambler and the channel encoder — both are shift-registers — can be integrated into a single device without further cost. The same is possible for the channel decoder (e.g. the Viterbi algorithm) and the descrambler. Thus, the additional requirements in the receiver are indeed kept at a minimum. As regards to the transmitter, the main cost is constituted by the U vector mappings and parallel IDFTs (cf. Fig. 1b). Assuming that the most expensive part of the transmitter are the IDFTs, the cost in the transmitter is roughly multiplied by U .

IV. SIMULATION RESULTS

A. System Parameters

To demonstrate the proposed SLM extension, we consider a system, which could be used for wireless Asynchronous Transfer Mode (ATM) devices. We employ $D = 256$ and $D_u = 219$ used carriers. The SLM processing is performed with an oversampling factor of two, i.e., IDFTs of size $2D$ with zero-padding are used to generate the candidate sample sequences. Those are analyzed with respect to peak power to obtain its classification for the selection process. The oversampled signal representation yields sufficiently accurate peak-power information on the final continuous-time signal $s(t)$ after impulse shaping. The root-raised cosine Nyquist

transmit filter to generate $s(t)$ in our simulations has a rolloff factor of $\alpha = 0.12$. The continuous-time signal simulation is performed with an oversampling of factor eight, i.e., $s(kT/8)$ is used to quantify the continuous-time characteristic of $s(t)$ and to simulate the power spectral density of $s'(t)$, which is the distorted transmit signal obtained by passing $s(t)$ through a possibly nonlinear device.

An Additive White Gaussian Noise (AWGN) channel with one-sided power spectral density N_0 is used, such that no guard interval needs to be implemented. Perfect synchronization is assumed.

We use a scrambler with a feedback polynomial $1 + x + x^4$ and a rate- $1/2$ industry-standard convolutional code with 64 states. The bits are interleaved and mapped onto the 16QAM symbols of one OFDM symbol using Gray labeling. Hence, an OFDM-symbolwise blocked convolutional-coded system results. Note that our proposal does not require this blocking.

B. Distribution of the Signal Amplitude

Fig. 5 illustrates simulation results for the probability that the instantaneous power $|s(t)|^2$ exceeds the threshold s_0^2 . The abscissa is normalized to the average transmit signal power σ_s^2 of $s(t)$.

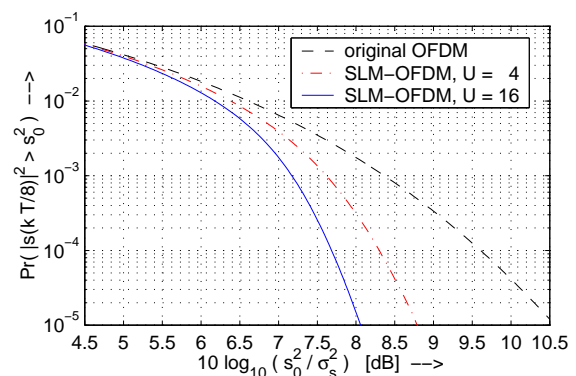
Fig. 5. Probability that the instantaneous power of the transmit signal $s(t)$ exceeds the value s_0^2 .

We want to coin the term *probabilistic PAR* for the normalized power threshold s_0^2/σ_s^2 which is connected with some fixed power-excess probability on a sample-by-sample basis. Hence, we can say that the probabilistic PAR of conventional OFDM at excess probability 10^{-5} is 10.6 dB. This expresses that one in 100000 samples exceeds a power threshold s_0^2 , which is by 10.6 dB larger than σ_s^2 . The resulting reduction of probabilistic PAR is 1.8 and 2.5 dB (at 10^{-5}) for SLM with $U = 4$ and $U = 16$, respectively.

16QAM modulation (PAR of the signal constellation \mathcal{A} : 2.55 dB) is used, but the statistics do not differ greatly, when

4PSK or 8PSK modulation is used (PAR of \mathcal{A} : 0 dB).

C. Bit Error Rate Performance

The demapper computes bitwise probabilities from the received subcarrier amplitudes. Perfect knowledge of noise variance and channel state is assumed.

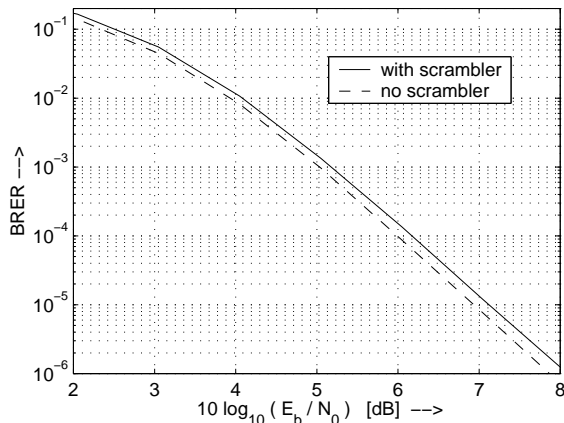

Fig. 6. Bit residual error rate after decoding without and with the scrambling SLM scheme.

In Fig. 6, we show the bit residual error rate (BRER) vs. SNR per bit information for conventional transmission (no scrambler) and SLM transmission (with scrambler). The rate loss for the label insertion is negligible. Due to error propagation in the receiver, we observe a small degradation in BRER which is typically around 0.2 dB caused by the increase in BRER by a factor lower than the weight of the scrambler polynomial.

D. Power Spectral Density

The continuous-time transmit signal $s(t)$ is generated from the OFDM sample sequence by a square-root Nyquist transmit filter with rolloff factor of $\alpha = 0.12$. This signal is passed through a possibly nonlinear device to obtain $s'(t)$. The out-of-band power after a simple soft-limiting nonlinearity² is evaluated by measuring the PSD of the distorted transmit signal $s'(t)$.

Fig. 7 shows the PSDs $\Phi_{s's'}(f)$ for the transmitted signal after an ideally linear as well as after a nonlinear characteristic. The transmission under ideal conditions leads to no spectral spread, while the transmission of original OFDM via a nonlinear device produces considerable out-of-band power for 6, 7, 8, and 9 dB backoff from saturation point. For comparison, we plotted the PSDs for SLM-OFDM with $U = 4$ and 16 candidates for 6 and 7 dB backoff. It can be concluded that — depending on the tolerated level of out-of-band density — between 1 and 2 dB can be saved in backoff with 4 bits redundancy per OFDM symbol.

As is the case with sample magnitude statistics, the results do not differ greatly, when 4PSK or 8PSK instead of 16QAM modulation is used in the subcarriers.

²The soft-limiter amplitude characteristic is ideally linear up to the perfectly horizontal saturation. The signal phase is not modified.

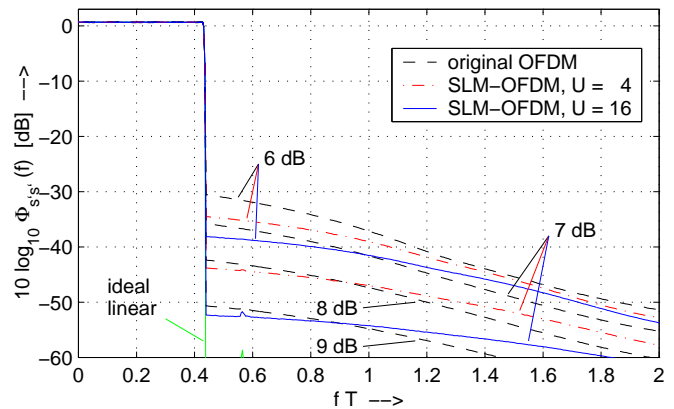

Fig. 7. Comparison of the power spectral density of $s'(t)$ at the output of the power amplifier (modelled by a soft-limiter) between OFDM without and with the extended SLM scheme with different numbers of generated candidate sequences and for various backoffs.

V. CONCLUSION

We proposed a powerful extension of SLM for PAR reduction and demonstrated its operability for the special case of convolutionally-coded OFDM transmission. The scheme refrains from explicit transmission of side information by a label insertion and scrambling approach. Only little redundancy is introduced into the signal and the BRER performance is degraded by 0.2 dB due to error propagation in the descrambler. Often, a scrambler is anyhow present in the transmitter to destroy long zero-bit sequences, so that this is no additional loss. On the other hand, the transmit signal statistics and the spectral properties in presence of transmitter nonlinearities are decisively improved such that a saving of 1 to 2 dB in backoff can easily be achieved.

With this proposal, the SLM scheme for PAR reduction gains additional attraction for practical implementation. We emphasize again that SLM is also suitable for other modulation schemes, e.g. single-carrier modulation.

ACKNOWLEDGEMENT

This work was supported by Ericsson Eurolab Deutschland GmbH, Nürnberg, and by the Fraunhofer Gesellschaft – Institut für Integrierte Schaltungen, Erlangen.

REFERENCES

- [1] Robert Bäuml, Robert Fischer, and Johannes Huber, "Reducing the Peak-to-Average Power Ratio of Multicarrier Modulation by Selected Mapping," *Electronics Letters*, vol. 32, no. 22, pp. 2056–2057, October 1996.
- [2] Stefan Müller-Weinfurter, *OFDM for Wireless Communications: Nyquist Windowing, Peak-Power Reduction, and Synchronization*, Reihe Kommunikations- und Informationstechnik, Band 16, ISBN 3-8265-7658-6. Shaker Verlag, Aachen, 2000, Dissertation Universität Erlangen-Nürnberg.
- [3] "German patent no. 199 58 210.6," 1999.
- [4] P. Van Eetvelt, G. Wade, and M. Tomlinson, "Peak to Average Power Reduction for OFDM Schemes by Selective Scrambling," *Electronics Letters*, vol. 32, no. 21, pp. 1963–1964, October 1996.
- [5] Denis J.G. Mestdagh and Paul M.P. Spruyt, "A Method to Reduce the Probability of Clipping in DMT-Based Transceivers," *IEEE Trans. on Commun.*, vol. 44, no. 10, pp. 1234–1238, October 1996.
- [6] Solomon Golomb, *Shift Register Sequences*, Aegean Park Press, revised edition, 1982.