



US008023463B2

(12) **United States Patent**
Dick et al.

(10) **Patent No.:** **US 8,023,463 B2**
(45) **Date of Patent:** ***Sep. 20, 2011**

(54) **ENHANCED UPLINK OPERATION IN SOFT HANDOVER** 370/328, 442, 333, 351, 412, 221, 225; 711/154; 455/436, 439, 438, 442, 426; 714/748, 749, 746, 751, 758, 764

(75) Inventors: **Stephen G. Dick**, Nesconset, NY (US); **Stephen E. Terry**, Northport, NY (US); **Guodong Zhang**, Farmingdale, NY (US); **James M. Miller**, Verona, NJ (US); **Sung-Hyuk Shin**, Northvale, NJ (US) See application file for complete search history.

(56) **References Cited**

U.S. PATENT DOCUMENTS

5,946,320 A 8/1999 Decker
6,434,396 B1 * 8/2002 Rune 455/502
(Continued)

FOREIGN PATENT DOCUMENTS

EP 1 217 777 6/2002
(Continued)

OTHER PUBLICATIONS

R1-03095, "Feasibility Study for Enhanced Uplink for UTRA FDD", 3GPP TR 25.896, V.0.4.2.

(73) Assignee: **InterDigital Technology Corporation**, Wilmington, DE (US)

(*) Notice: Subject to any disclaimer, the term of this patent is extended or adjusted under 35 U.S.C. 154(b) by 661 days.

This patent is subject to a terminal disclaimer.

(21) Appl. No.: **10/925,426**

(22) Filed: **Aug. 25, 2004**

(65) **Prior Publication Data**

US 2005/0111389 A1 May 26, 2005

Related U.S. Application Data

(60) Provisional application No. 60/497,747, filed on Aug. 25, 2003, provisional application No. 60/507,554, filed on Oct. 1, 2003, provisional application No. 60/508,797, filed on Oct. 3, 2003, provisional application No. 60/520,207, filed on Nov. 14, 2003, provisional application No. 60/585,174, filed on Jul. 2, 2004.

(51) **Int. Cl.**

G06F 11/30 (2006.01)
H04W 4/00 (2009.01)
H04W 36/00 (2009.01)

(52) **U.S. Cl.** 370/331; 714/746; 455/442

(58) **Field of Classification Search** 370/216, 370/218, 329, 330, 331, 332, 278, 282, 279,

Primary Examiner — Hanh Nguyen

(74) *Attorney, Agent, or Firm* — Volpe and Koenig, P.C.

(57) **ABSTRACT**

A method and system for an enhanced uplink (EU) operation in a wireless communication system during soft handover. The system comprises a wireless transmit/receive unit (WTRU), at least two Node-Bs, and a radio network controller (RNC). One Node-B may be designated as a primary Node-B, and the primary Node-B may control EU operation during soft handover including uplink scheduling and hybrid automatic repeat request (H-ARQ). Soft buffer corruption is avoided during soft handover by controlling H-ARQ by the primary Node-B. Alternatively, an RNC may control EU operation during soft handover including H-ARQ. In this case, an RNC generates final acknowledge/non-acknowledge (ACK/NACK) decision based on the error check results of the Node-Bs.

22 Claims, 9 Drawing Sheets

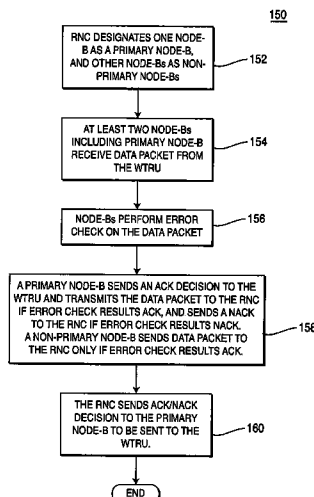

U.S. PATENT DOCUMENTS

6,643,813	B1 *	11/2003	Johansson et al.	714/748
6,678,249	B2	1/2004	Toskala et al.	
6,678,523	B1 *	1/2004	Ghosh et al.	455/442
6,907,245	B2	6/2005	Ohlsson et al.	
6,915,465	B2 *	7/2005	Fujiwara et al.	714/712
6,977,888	B1 *	12/2005	Frenger et al.	370/218
7,046,648	B2 *	5/2006	Zhang et al.	370/331
7,054,633	B2 *	5/2006	Seo et al.	455/439
7,103,729	B2 *	9/2006	Altahan et al.	711/154
7,124,350	B2 *	10/2006	Chao et al.	714/776
7,185,256	B2	2/2007	Miki et al.	
7,269,420	B2 *	9/2007	Heo et al.	455/436
7,283,508	B2 *	10/2007	Choi et al.	370/341
7,315,741	B2 *	1/2008	Chun	455/436
7,317,700	B2 *	1/2008	Hwang	370/328
7,403,513	B2 *	7/2008	Lee et al.	370/342
2002/0093937	A1	7/2002	Kim et al.	
2003/0081692	A1	5/2003	Kwan et al.	
2003/0202500	A1	10/2003	Ha et al.	
2006/0045010	A1	3/2006	Baker et al.	
2006/0105796	A1	5/2006	Malladi et al.	
2007/0079207	A1	4/2007	Seidel et al.	

FOREIGN PATENT DOCUMENTS

KR	2003-0003943	1/2003
WO	02/03782	5/2002
WO	02/47317	6/2002
WO	02/082108	10/2002
WO	03/047155	6/2003

OTHER PUBLICATIONS

R1-030765, "HARQ performance in soft handover", Samsung, TSG RAN1 #33.

R1-030733, "HARQ overhead issues", Nokia, TSG-RAN1 #33.

3GPP2 C.20003-C, "Medium Access Control (MAC) Standard for cdma2000 Spread Spectrum Systems", 3rd Generation Partnership Project 2 "3GPP2", Version 2.0, Release C, Aug. 2004.

3GPP2 C.S0004-C, "Signaling Link Access Control (LAC) Standard for cdma2000 Spread Spectrum Systems", 3rd Generation Partnership Project 2 "3GPP2", Version 2.0, Revision C, Jul. 23, 2004.

3GPP2 C.S0005-C, "Upper Layer (Layer 3) Signaling Standard for cdma2000 Spread Spectrum Systems", 3rd Generation Partnership Project 2 "3GPP2", Version 2.0, Revision c, Jul. 23, 2004.

3GPP TS 25.309 V0.2.0, 3rd Generation Partnership Project; Technical Specification Group Radio Access Network; "FDD Enhanced Uplink"; Stage 2 (Release 6); Jun. 2004.

3GPP TS 25.133 V6.6.0, 3rd Generation Partnership Project; Technical Specification Group Radio Access Network; "Requirements For Support of Radio Resource Management" (FDD); (Release 6); Jun. 2004.

3GPP TS 25.308 V6.1.0, 3rd Generation Partnership Project; Technical Specification Group Radio Access Network; "High Speed Downlink Packet Access (HSDPA)"; Stage 2 (Release 6); Mar. 2004.

3GPP TS 25.133 V6.2.0, 3rd Generation Partnership Project; Technical Specification Group Radio Access Network; "Requirement for Support of Radio Resource Management" (FDD); (Release 6); Jun. 2003.

3GPP TS 25.308 V5.4.0, 3rd Generation Partnership Project; Technical Specification Group Radio Access Network; "High Speed Downlink Packet Access (HSDPA)"; Stage 2 (Release 5); Mar. 2003.

R1-030803, "HARQ operation during Soft Handover", Panasonic, TSG RAN1 #33.

3GPP2 C.S0002-C, "Physical Layer Standard for cdma2000 Spread Spectrum Systems", 3rd Generation Partnership Project 2 "3GPP2", Version 2.0, Revision C, Jul. 23, 2004.

3GPP, "3rd Generation Partnership Project; Technical Specification Group Radio Access Network; Medium Access Control (MAC) protocol specification (Release 6)," 3GPP TS 25.321 V6.2.0 (Jun. 2004).

3GPP, "3rd Generation Partnership Project; Technical Specification Group Radio Access Network; Physical Layer Procedures (FDD) (Release 6)," 3GPP TS 25.214 V6.2.0 (Jun. 2004).

3GPP, "3rd Generation Partnership Project; Technical Specification Group Radio Access Network; Physical Layer Procedures (FDD) (Release 5)," 3GPP TS 25.214 V5.9.0 (Jun. 2004).

3GPP, "3rd Generation Partnership Project; Technical Specification Group Radio Access Network; Physical Layer Procedures (FDD) (Release 5)," 3GPP TS 25.214 V5.5.0 (Jun. 2003).

3GPP, "3rd Generation Partnership Project; Technical Specification Group Radio Access Network; Physical Layer Procedures (FDD) (Release 4)," 3GPP TS 25.214 V4.6.0 (Mar. 2003).

3GPP, "3rd Generation Partnership Project; Technical Specification Group Radio Access Network; Physical Layer Procedures (FDD) (Release 1999)," 3GPP TS 25.214 V3.12.0 (Mar. 2003).

3GPP, "3rd Generation Partnership Project; Technical Specification Group Radio Access Network; Medium Access Control (MAC) protocol specification (Release 1999)," 3GPP TS 25.321 V3.17.0 (Jun. 2004).

3GPP, "3rd Generation Partnership Project; Technical Specification Group Radio Access Network; Medium Access Control (MAC) protocol specification (Release 1999)," 3GPP TS 25.321 V3.15.0 (Mar. 2003).

3GPP, "3rd Generation Partnership Project; Technical Specification Group Radio Access Network; Medium Access Control (MAC) protocol specification (Release 5)," 3GPP TS 25.321 V5.5.0 (Jun. 2003).

3GPP, "3rd Generation Partnership Project; Technical Specification Group Radio Access Network; Medium Access Control (MAC) protocol specification (Release 4)," 3GPP TS 25.321 V4.10.0 (Jun. 2004).

3GPP, "3rd Generation Partnership Project; Technical Specification Group Radio Access Network; Medium Access Control (MAC) protocol specification (Release 4)," 3GPP TS 25.321 V4.8.0 (Mar. 2003).

3GPP, "3rd Generation Partnership Project; Technical Specification Group Radio Access Network; Medium Access Control (MAC) protocol specification (Release 5)," 3GPP TS 25.321 V5.9.0 (Jun. 2004).

3GPP, "3rd Generation Partnership Project; Technical Specification Group Radio Access Network; High Speed Downlink Packet Access (HSDPA)"; Stage 2 (Release 5), 3GPP TS 25.308 V5.5.0 (Mar. 2004).

3GPP, "3rd Generation Partnership Project; Technical Specification Group Radio Access Network; Medium Access Control (MAC) protocol specification (Release 1999)," 3GPP TS 25.321 V3.15.0 (Mar. 2003).

3GPP, "3rd Generation Partnership Project; Technical Specification Group Radio Access Network; Medium Access Control (MAC) protocol specification (Release 5)," 3GPP TS 25.321 V5.5.0 (Jun. 2003).

3GPP, "3rd Generation Partnership Project; Technical Specification Group Radio Access Network; Medium Access Control (MAC) protocol specification (Release 4)," 3GPP TS 25.321 V4.10.0 (Jun. 2004).

3GPP, "3rd Generation Partnership Project; Technical Specification Group Radio Access Network; Medium Access Control (MAC) protocol specification (Release 4)," 3GPP TS 25.321 V4.8.0 (Mar. 2003).

3GPP, "3rd Generation Partnership Project; Technical Specification Group Radio Access Network; Medium Access Control (MAC) protocol specification (Release 5)," 3GPP TS 25.321 V5.9.0 (Jun. 2004).

3GPP, "3rd Generation Partnership Project; Technical Specification Group Radio Access Network; High Speed Downlink Packet Access (HSDPA)"; Stage 2 (Release 5), 3GPP TS 25.308 V5.5.0 (Mar. 2004).

3GPP2 C.20003-C, "Medium Access Control (MAC) Standard for cdma2000 Spread Spectrum Systems", 3rd Generation Partnership Project 2 "3GPP2", Version 2.0, Release C, Aug. 2004.

3GPP2 C.S0002-C, "Physical Layer Standard for cdma2000 Spread Spectrum Systems", 3rd Generation Partnership Project 2 "3GPP2", Version 2.0, Revision C, Jul. 23, 2004.

3GPP2 C.S0004-C, "Signaling Link Access Control (LAC) Standard for cdma2000 Spread Spectrum Systems", 3rd Generation Partnership Project 2 "3GPP2", Version 2.0, Revision C, Jul. 23, 2004.

3GPP2 C.S0005-C, "Upper Layer (Layer 3) Signaling Standard for cdma2000 Spread Spectrum Systems", 3rd Generation Partnership Project 2 "3GPP2", Version 2.0, Revision c, Jul. 23, 2004.

R1-030733, "HARQ overhead issues", Nokia, TSG-RAN1 #33, Aug. 25-29, 2003.

R1-030765, "HARQ performance in soft handover", Samsung, TSG RAN1 #33, Sep. 2003.

R1-030803, "HARQ operation during Soft Handover", Panasonic, TSG RAN1 #33, Aug. 25-29, 2003.

R1-03095, "Feasibility Study for Enhanced Uplink for UTRA FDD", 3GPP TR 25.896, V.0.4.2, Sep. 2003.

3GPP, "3rd Generation Partnership Project; Technical Specification Group Radio Access Network; Medium Access Control (MAC) protocol specification (Release 1999)," 3GPP TS 25.321 V3.15.0 (Mar. 2003).

3GPP, "3rd Generation Partnership Project; Technical Specification Group Radio Access Network; Medium Access Control (MAC) protocol specification (Release 5)," 3GPP TS 25.321 V5.5.0 (Jun. 2003).

3GPP, "3rd Generation Partnership Project; Technical Specification Group Radio Access Network; Medium Access Control (MAC) protocol specification (Release 4)," 3GPP TS 25.321 V4.10.0 (Jun. 2004).

3GPP, "3rd Generation Partnership Project; Technical Specification Group Radio Access Network; Medium Access Control (MAC) protocol specification (Release 4)," 3GPP TS 25.321 V4.8.0 (Mar. 2003).

3GPP, "3rd Generation Partnership Project; Technical Specification Group Radio Access Network; Medium Access Control (MAC) protocol specification (Release 5)," 3GPP TS 25.321 V5.9.0 (Jun. 2004).

3GPP, "3rd Generation Partnership Project; Technical Specification Group Radio Access Network; High Speed Downlink Packet Access (HSDPA)"; Stage 2 (Release 5), 3GPP TS 25.308 V5.5.0 (Mar. 2004).

3GPP2 C.20003-C, "Medium Access Control (MAC) Standard for cdma2000 Spread Spectrum Systems", 3rd Generation Partnership Project 2 "3GPP2", Version 2.0, Release C, Aug. 2004.

3GPP2 C.S0002-C, "Physical Layer Standard for cdma2000 Spread Spectrum Systems", 3rd Generation Partnership Project 2 "3GPP2", Version 2.0, Revision C, Jul. 23, 2004.

3GPP2 C.S0004-C, "Signaling Link Access Control (LAC) Standard for cdma2000 Spread Spectrum Systems", 3rd Generation Partnership Project 2 "3GPP2", Version 2.0, Revision C, Jul. 23, 2004.

3GPP2 C.S0005-C, "Upper Layer (Layer 3) Signaling Standard for cdma2000 Spread Spectrum Systems", 3rd Generation Partnership Project 2 "3GPP2", Version 2.0, Revision c, Jul. 23, 2004.

Heck et al., "Diversity Effects on the Soft Handover Gain in UMTS Networks," Proceedings of the IEEE Vehicular Technology Conference, vol. 2, pp. 1269-1273 (Sep. 2002).

* cited by examiner

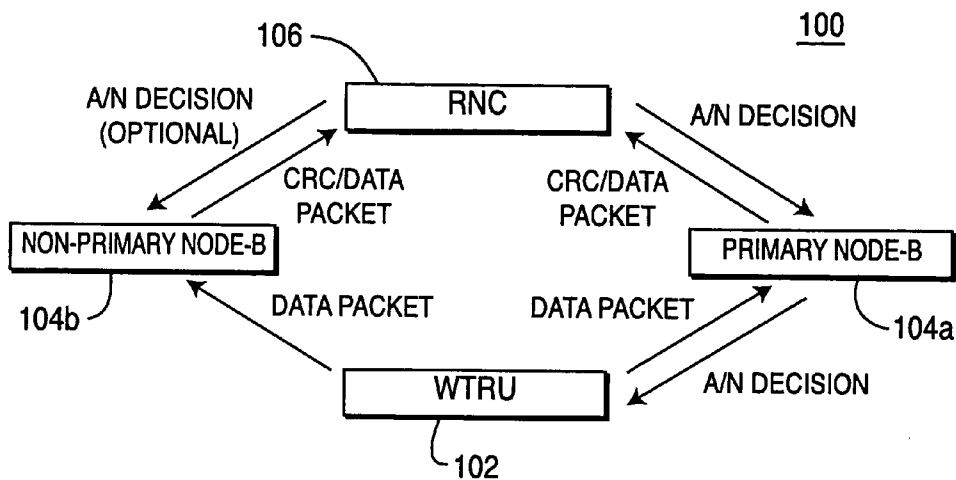

FIG. 1A

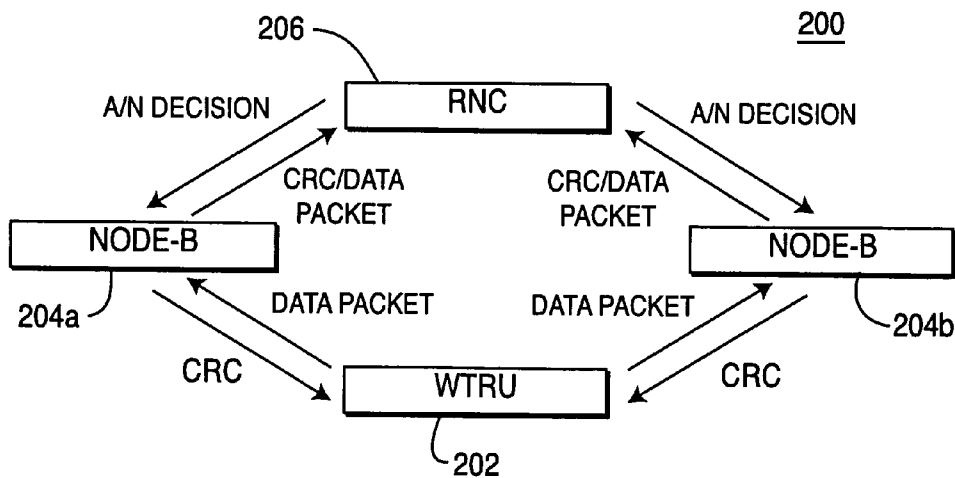

FIG. 2A

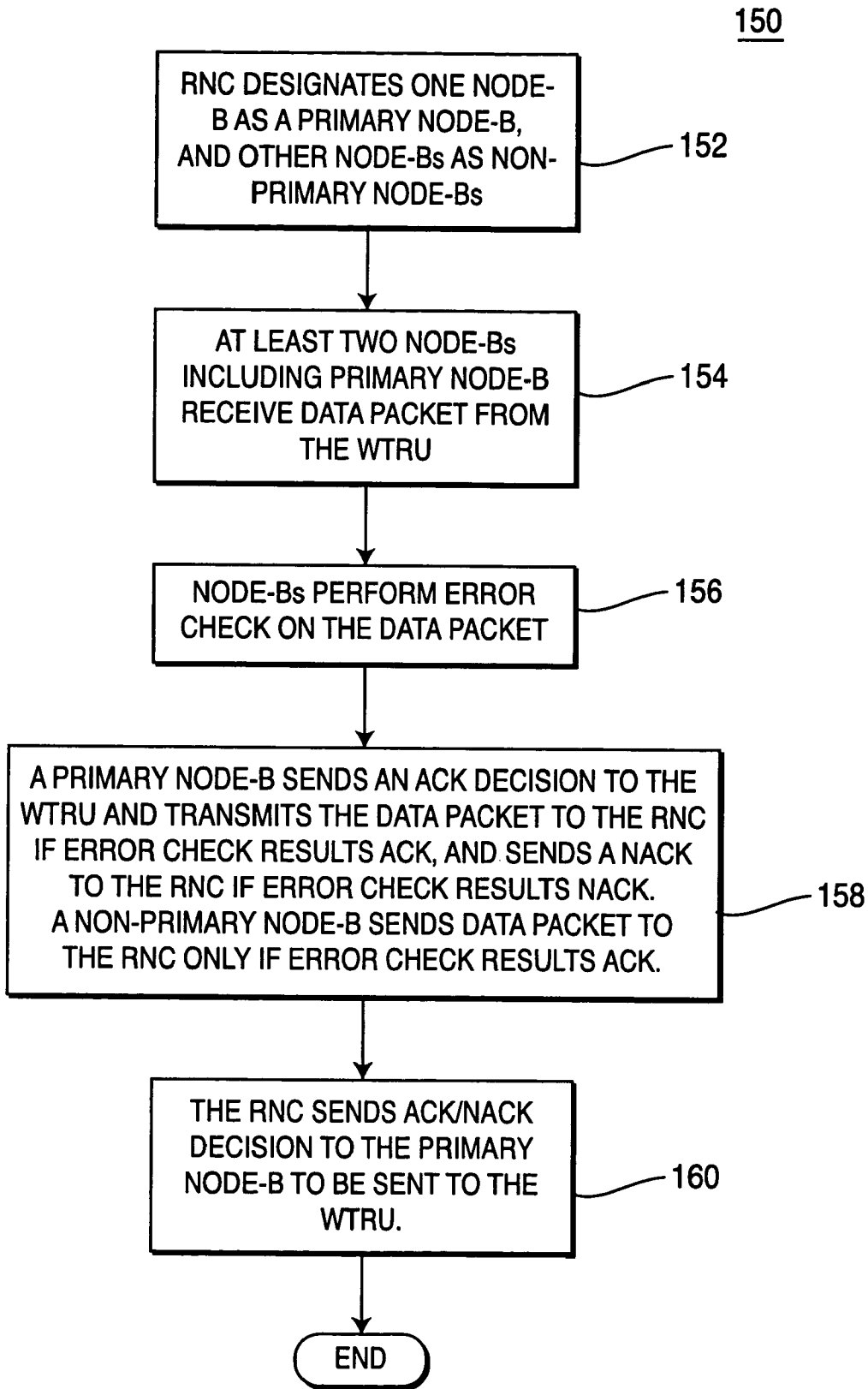

FIG. 1B

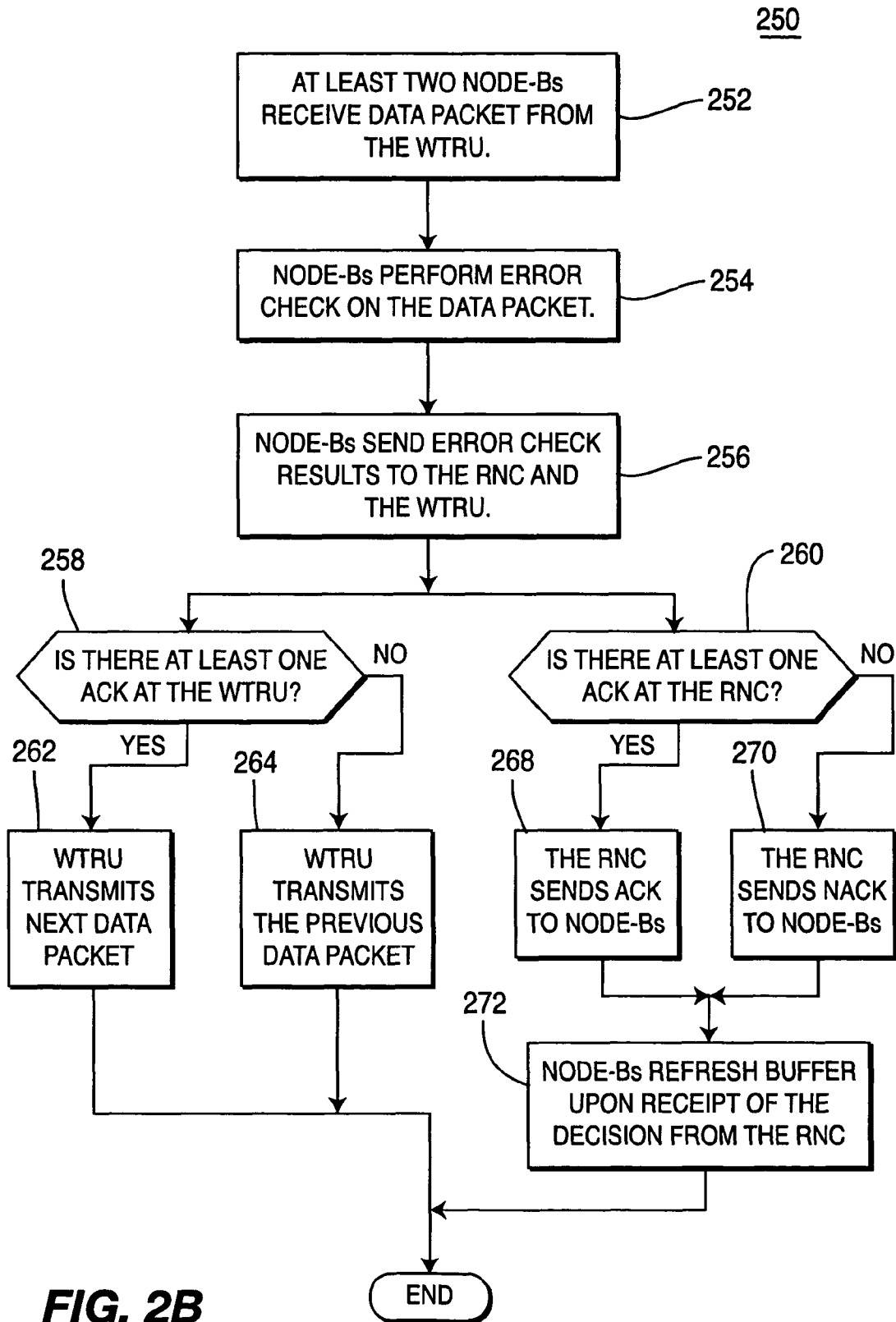

FIG. 2B

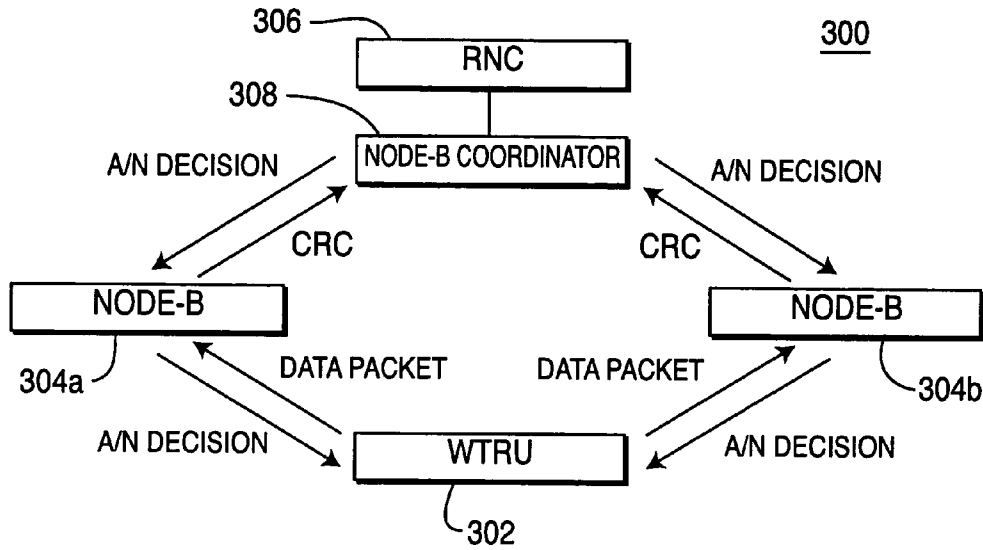

FIG. 3A

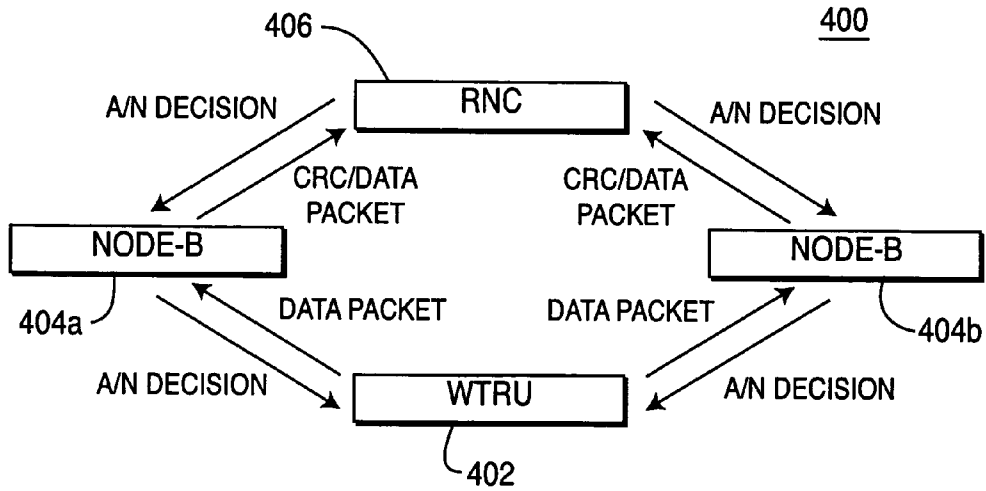

FIG. 4A

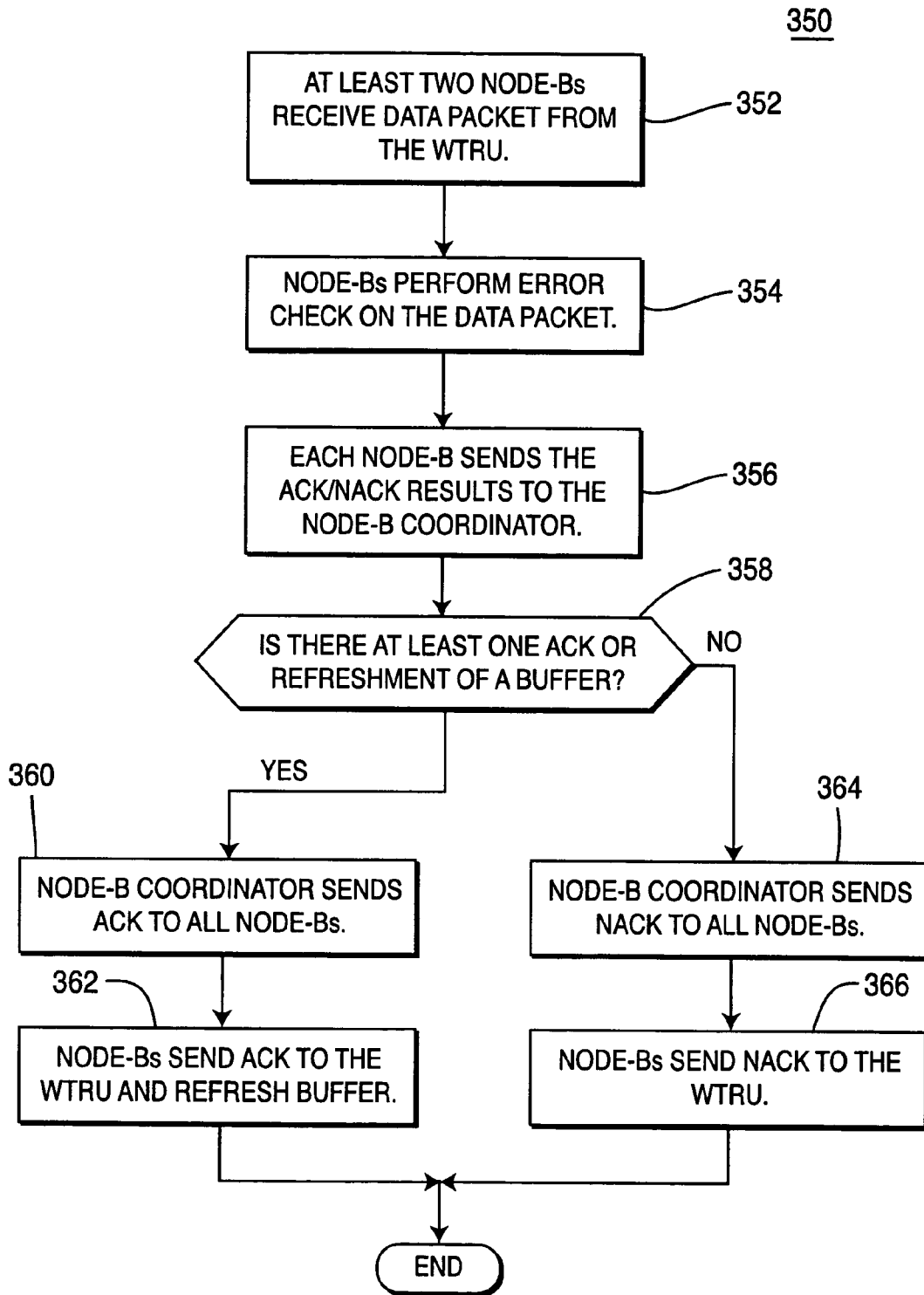

FIG. 3B

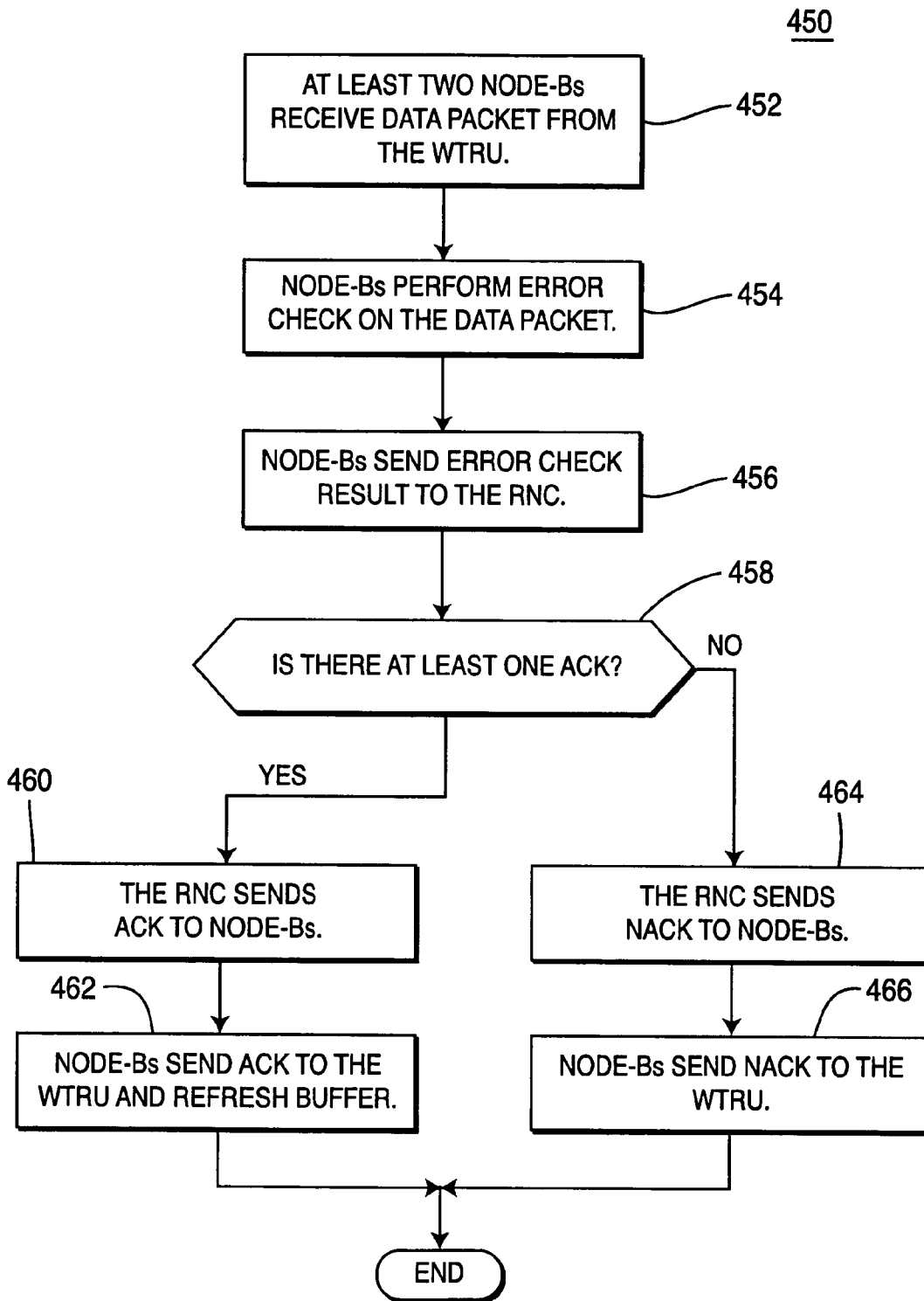

FIG. 4B

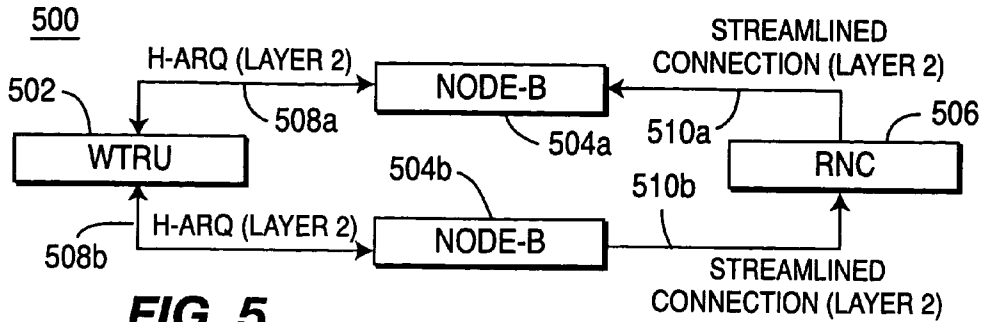

FIG. 5

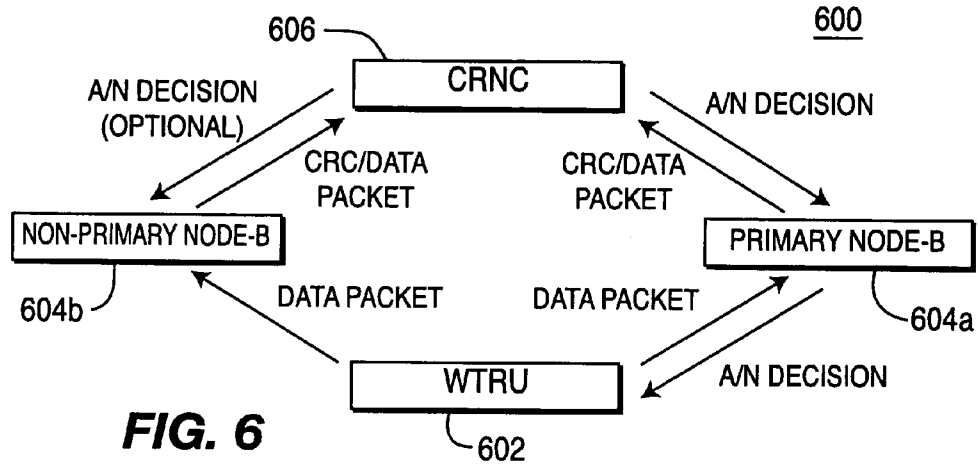

FIG. 6

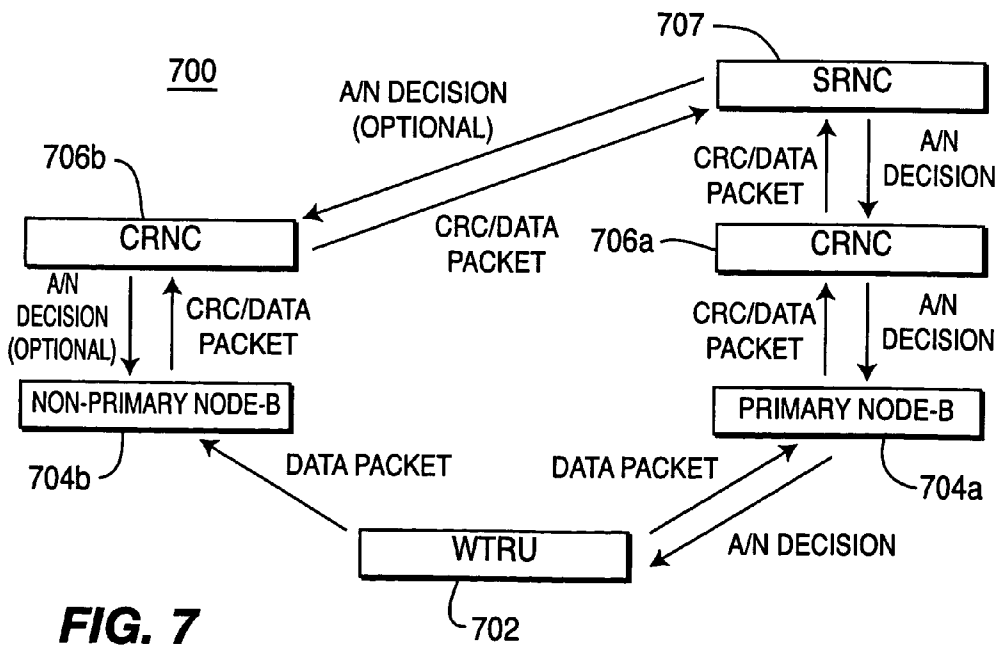

FIG. 7

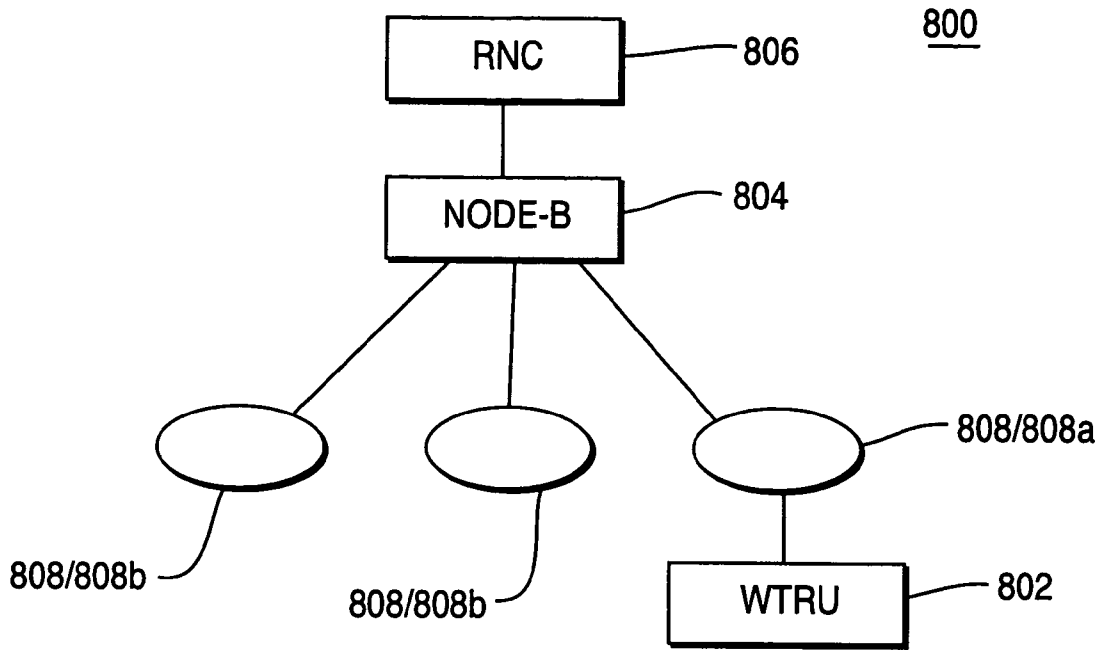

FIG. 8A

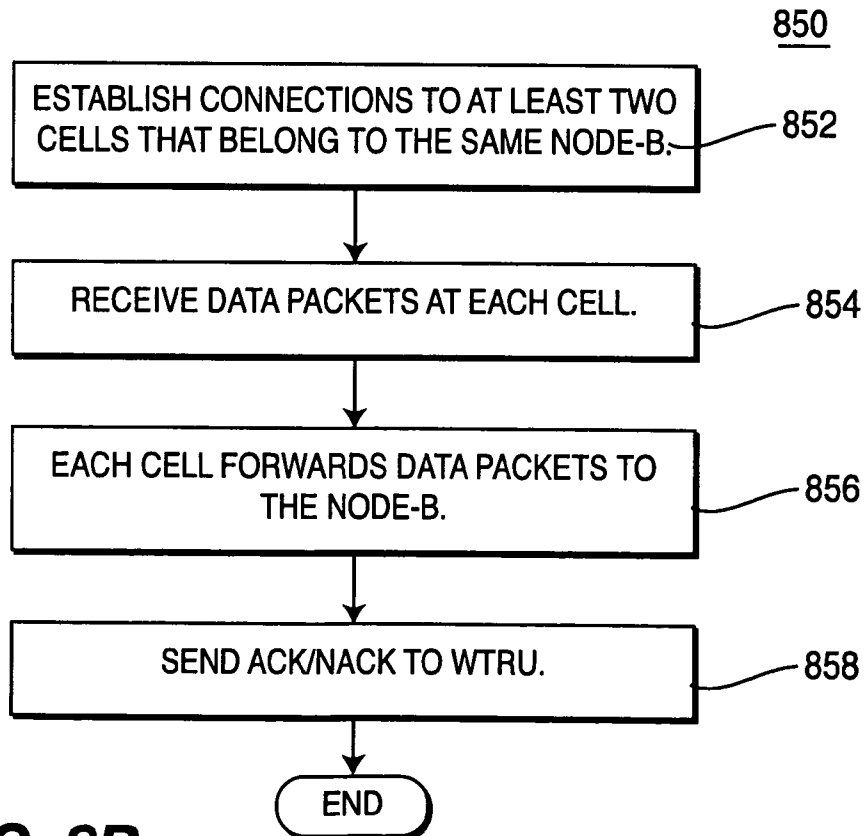

FIG. 8B

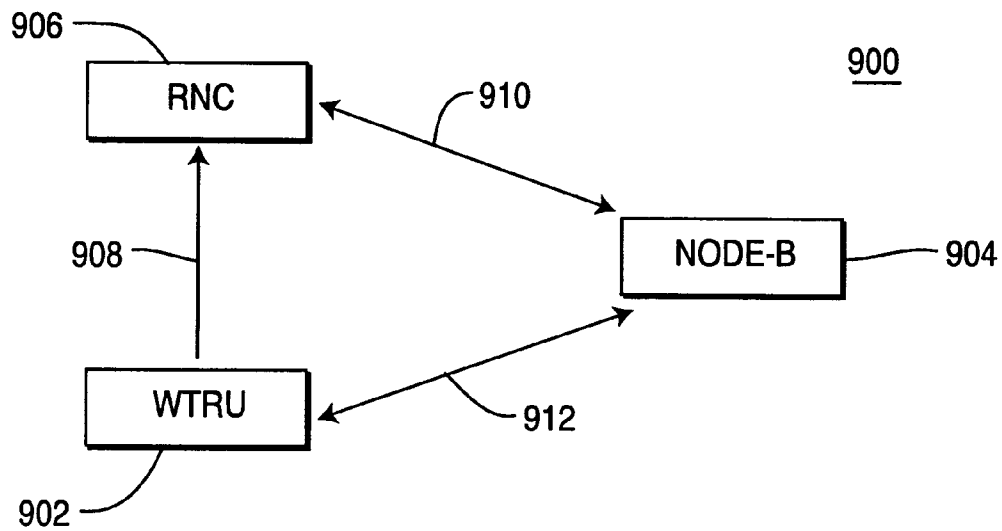

FIG. 9

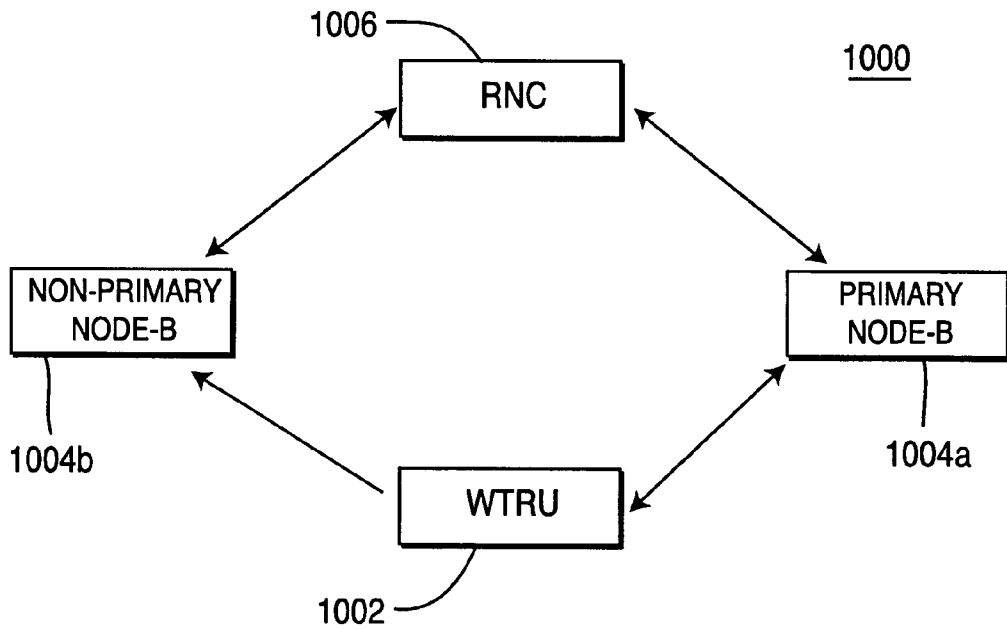

FIG. 10

1

ENHANCED UPLINK OPERATION IN SOFT HANDOVER

CROSS REFERENCE TO RELATED APPLICATION

This application claims priority from U.S. provisional application Nos. 60/497,747 filed on Aug. 25, 2003, 60/507,554 filed on Oct. 1, 2003, 60/508,797 filed on Oct. 3, 2003, 60/520,207 filed on Nov. 14, 2003 and 60/585,174 filed on Jul. 2, 2004, which are incorporated by reference as if fully set forth.

FIELD OF INVENTION

The present invention is related to a wireless communications. More particularly, the present invention is related to an enhanced uplink (EU) operation during a soft handover.

BACKGROUND

Cellular wireless communication networks are divided into a plurality of coverage regions. Each coverage region in the network is served by a Node-B. As a wireless transmit/receive unit (WTRU) travels, it may move from one coverage region to another in the network.

The WTRU is served by the designated Node-B for a particular coverage region. The regions covered by Node-Bs overlap each other, and at the boundary of the region a WTRU can establish connections with more than one Node-B. As the WTRU moves from one coverage region to another in the network, the WTRU goes through handover. Soft handover is widely used to ensure communication without interruption while roving around a plurality of cells.

Soft handover occurs when a WTRU is connected to two or more Node-Bs simultaneously, on the same frequency. In soft handover, all Node-Bs serving the WTRU process the received data, which is then routed to a radio network controller (RNC) for macro diversity combining. For simplicity, the RNC may use an error detection technique such as a Cyclic Redundancy Check (CRC) and may accept a packet that passes the CRC.

Softer handover is a special case of soft handover. When a WTRU is in softer handover, the WTRU is connected to two or more cells belonging to the same Node-B. In contrast to soft handover, in softer handover macro diversity with or without maximum ratio combining can be performed in the Node-B.

Automatic repeat request (ARQ) is a technique whereby the receiver requests a retransmission of packets by the transmitter if errors are detected. Hybrid ARQ (H-ARQ) is a technique whereby transmitted data blocks are encoded for partial error correction at the receiver, and only data blocks with uncorrected errors are retransmitted. In prior art, i.e. in high speed downlink packet access (HSDPA), the H-ARQ functionality is terminated and controlled by the Node-B, (a technique called Node-B-controlled H-ARQ), allowing for rapid transmissions and retransmissions of erroneously received packets. This feature was both highly desirable and practical because H-ARQ in HSDPA was not required for soft handover. This feature would be highly desirable for EU also, but problems exist because it is intended for EU (and H-ARQ) to operate during soft handover.

One of the problems with Node-B-controlled H-ARQ in soft handover is the link imbalance. Since the associated uplink (UL) and downlink (DL) control signaling does not benefit from the soft handover gain, it might be error prone

2

and require significant power offsets. In the DL direction, the WTRU may not be able to receive the acknowledge (ACK) or non-acknowledge (NACK) signals from all involved Node-Bs. In the UL, not all involved Node-Bs may be able to receive the associated control signaling from the WTRU, which may lead to soft buffer corruption.

A soft buffer is a buffer for implementing H-ARQ in a Node-B. Data packets received, but not acknowledged, by the Node-B are temporarily stored in the soft buffer for incremental combining. Therefore, a data packet transmitted, but not acknowledged previously, is combined with a retransmission of the same data packet transmitted in response to NACK signaling. Chase combining is a special case of an incremental combining. The soft buffer corruption causes misalignment of an H-ARQ protocol state among different Node-Bs and leads to loss of the soft handover gain. It would be desirable to achieve efficient H-ARQ operation without the problems associated with prior art systems.

Node-Bs can often make more efficient decisions and manage UL radio resources on a short-term basis better than an RNC, even if the RNC retains overall control over Node-Bs. In order for a Node-B to assign UL radio resources to WTRUs in EU operation, the Node-B must know several WTRU-specific parameters. Under the current 3GPP standard, only the RNC can know the WTRU-specific parameters by means of radio resource control (RRC) messages. Therefore, it is necessary to forward the information to the Node-B for proper scheduling of radio resources in EU transmissions.

An RNC maintains an active set of cells for each WTRU in soft handover. The RNC bases its decision to add to or remove cells from the WTRU's active set upon measurements provided by a WTRU and a Node-B and on management of available radio resources in each cell. Under the current 3GPP standards, the RNC applies RRC radio bearer (RB) control procedures to coordinate active set cells with the WTRU, and Node-B application part/radio network subsystem application part (NBAP/RNSAP) radio link procedures to coordinate active set cells with each Node-B.

During soft handover, some information should be communicated between network entities to support EU operation. The information includes, but is not limited to, information related to an active set, information regarding a Node-B that controls transmissions during soft handover, EU scheduling information during soft handover, and ACK/NACK status information during soft handover. The current 3GPP standards do not define specific protocols to transfer necessary information which are imperative in operation of EU during soft handover. Therefore, it is necessary to define a protocol for transferring WTRU-specific information and other EU related information among an RNC, a Node-B, and a WTRU so that a Node-B is enabled to schedule radio resources and EU connections are handed over properly during soft handover.

SUMMARY

The present invention is related to EU operation during a soft handover in a wireless communication system. The wireless communication system comprises a WTRU, at least two Node-Bs, and an RNC. In accordance with one embodiment of the present invention, for each WTRU one Node-B is designated as a primary Node-B and any other Node-B within the EU active set as a non-primary Node-B. The primary Node-B controls EU operation during soft handover including EU scheduling and H-ARQ. Soft buffer corruption is avoided by controlling H-ARQ during soft handover only by the primary Node-B. Alternatively, an RNC may control EU

operation during soft handover including H-ARQ. In this case, an RNC generates final ACK/NACK decision based on the error check results of the Node-Bs.

BRIEF DESCRIPTION OF THE DRAWINGS

FIGS. 1A and 1B are diagrams of the first embodiment of the present invention.

FIGS. 2A and 2B are diagrams of the second embodiment of the present invention.

FIGS. 3A and 3B are diagrams of the third embodiment of the present invention.

FIGS. 4A and 4B are diagrams of the fourth embodiment of the present invention.

FIG. 5 is a diagram showing a streamlined connection between Node-Bs and an RNC in accordance with the present invention.

FIGS. 6 and 7 are diagrams of systems for transferring ACK/NACK signals in accordance with the present invention.

FIGS. 8A and 8B are diagrams of a system and process for softer handover in accordance with the present invention.

FIG. 9 is a diagram for transferring WTRU-specific information among network entities in accordance with the present invention.

FIG. 10 is a diagram for transferring information during handover among network entities in accordance with the present invention.

DETAILED DESCRIPTION OF THE PREFERRED EMBODIMENTS

The present invention will be described with reference to the drawing figures wherein like numerals represent like elements throughout.

When referred to hereafter, the terminology "WTRU" includes but is not limited to a user equipment, a mobile station, fixed or mobile subscriber unit, pager, or any other type of device capable of operating in a wireless environment. When referred to hereafter, the terminology "Node-B" includes but is not limited to a base station, site controller, access point or any other type of interfacing device in a wireless environment.

FIGS. 1A and 1B are diagrams of a system 100 and a process 150 of a first embodiment of the present invention. The WTRU 102 establishes connections with at least two cells controlled by different Node-Bs 104a, 104b for soft handover. Data packets transmitted from the WTRU 102 are received and processed separately by at least two Node-Bs 104a, 104b during soft handover (step 152).

One Node-B in a group of Node-Bs in an "active set" is designated as a primary Node-B 104a, while other Node-Bs in the active set are designated as non-primary Node-Bs 104b. An RNC 106 or the WTRU 102 makes this decision (step 152). If it is decided by an RNC 106, the RNC 106 informs all Node-Bs 104a, 104b and the WTRU 102. If it is decided by a WTRU 102, the WTRU 102 informs either all Node-Bs 104a, 104b or the RNC 106 which in turn informs all the Node-Bs 104a, 104b.

In making a decision regarding the primary Node-B 104a, the RNC 106 may use statistics, i.e. the number of successful decodings of particular WTRUs transmissions by each Node-B 104a, 104b, to identify the Node-B 104a, 104b with the best UL performance. It is the performance of the best cell controlled by a Node-B that is evaluated, not the performance of all cells associated with a Node-B. The RNC 106 may also select the primary Node-B 104a by evaluating both UL per-

formance as described above and DL performance as obtained from WTRU 102 measurements. The RNC 106 then notifies the Node-Bs 104a, 104b and the WTRU 102 regarding which one will be the primary Node-B 104a via Iub signaling and RRC signaling, respectively. The WTRU 102 may also be informed of the primary Node-B 104a by fast layer 1 signaling from Node-B.

The primary Node-B 104a employs incremental combining, while non-primary Node-Bs 104b may or may not use incremental combining. If the non-primary Node-Bs 104b do not use incremental combining, the non-primary Node-Bs 104b may use simple ARQ, and may always refresh their buffers and not perform any combining. This scheme eliminates the problem of soft buffer corruption in soft handover. If both a primary Node-B 104a and non-primary Node-Bs 104b perform incremental combining, soft buffer corruption may be eliminated with a new data indicator or a sequence number in physical control signaling sent by the WTRU 102 to inform Node-Bs 104a, 104b which data packet is being transmitted, and thereby the Node-Bs 104a, 104b can manage soft buffer without corruption.

All Node-Bs 104a, 104b in the active set receive a data packet from the WTRU 102 (step 154). Each Node-B 104a, 104b performs an error check on the data packet and generates an indication of success or failure in decoding the data packet (step 156). Determining whether a data packet is successfully received is performed via an error check procedure; such as implementing a cyclic redundancy check (CRC). The indication of success or failure in decoding the data packet by the Node-Bs can be configured in a variety of different forms, but will be referred to hereinafter as a CRC result, or an ACK/NACK, in all embodiments of the present invention. However, any type of error checking may be performed in accordance with the teachings of the present invention, and it should be understood that the term "CRC" or "ACK/NACK" is used only as an illustration, not as a limitation, of the present invention.

When a Node-B 104a, 104b correctly decodes the data packet as determined by the error check, the Node-B 104a, 104b transmits the data packet to the RNC 106. If the primary Node-B 104a derives an ACK from the data packet, it transmits an ACK signal to the WTRU 102 and the RNC 106 without waiting for the CRC results from non-primary Node-Bs 104b, and refreshes soft buffer (step 158). If the primary Node-B 104a derives a NACK from the data packet, it transmits a NACK to the RNC and waits for the final decision from the RNC or CRC results from non-primary Node-Bs forwarded through the RNC 106 (step 158). The primary Node-B 104a may set a timer as will be explained hereinafter. The primary Node-B 104a transmits an ACK/NACK signal to the WTRU 102 in accordance with the final decision made by the RNC 106 or CRC results forwarded from non-primary Node-Bs 104b.

Non-primary Node-Bs 104b transmit a data packet to the RNC 106 only if they derive an ACK from the data packet (step 158). The RNC 106 makes an ACK/NACK decision (step 160). If the RNC 106 receives at least one ACK from Node-Bs 104a, 104b, the RNC 106 makes an ACK decision, and if the RNC 106 receives no ACK from Node-Bs 104a, 104b within a predetermined time period, the RNC 106 makes a NACK decision. The RNC 106 transmits an ACK/NACK decision to the primary Node-B 104a. The RNC 106 may not send an ACK decision to the primary Node-B 104a when the primary Node-B 104a derives an ACK. The RNC 106 optionally transmits the ACK/NACK decision to the non-

5

primary Node-Bs 104b for soft buffer management depending on the scheme of incremental combining at the non-primary Node-Bs 104b.

It is optional for the RNC 106 to use the packets delivered from non-primary Node-Bs 104b. If the RNC 106 uses the packet from non-primary Node-Bs 104b, a media access control (MAC) function of the RNC 106 performs an in-sequence delivery mechanism over all the received packets from all the involved Node-Bs 104a, 104b. If a Radio Link Control (RLC) layer realized an out of sequence transmission it assumes data is lost and requests retransmission. If the RNC 106 does not use the packets from non-primary Node-Bs 104b, the RNC 106 processes only the packets received from the primary Node-B 104a. The RNC 106 extracts and enters the data packet into the MAC level reordering buffer. After the RNC MAC performs the re-sequencing process, it sends the data to the RLC layer. Missed packets are identified and notified to the WTRU 102 through RLC messaging.

Optionally, a streamlined connection may be implemented in transmission of the result of the error check between Node-Bs and an RNC. A fast streamlined connection is explained with reference to FIG. 5. The streamlined connection is dedicated to fast signaling between the RNC 506 and the Node-Bs 504a, 504b, and eliminates a long delay between the RNC 506 and Node-Bs 504a, 504b. A high speed streamlined connection 510a, 510b is established between Node-Bs 504a, 504b and an RNC 506. CRC results from Node-Bs 504a, 504b to the RNC 506 and an ACK/NACK decisions from the RNC 506 to Node-Bs 504a, 504b are transmitted via the streamlined connections 510a, 510b. No direct physical link is required between Node-Bs 504a, 504b. Rather, a logical channel between Node-Bs 504a, 504b is required. The RNC 506 coordinates establishing the logical channel.

A fast streamlined connection 510a, 510b may be implemented in accordance with two alternatives. In accordance with the first alternative, two logical channels are established between an RNC 506 and two Node-Bs 504a, 504b, respectively. The RNC 506 receives H-ARQ signaling 510b from one Node-B 504b and processes it before forwarding it 510a to another Node-B 504a. The RNC 506 recognizes the status of H-ARQ process of each Node-B 504a, 504b by processing the signaling. As explained above, the CRC results are processed by the RNC 506 and the RNC 506 makes a final ACK/NACK decision and transmits the ACK/NACK decision to the Node-Bs 504a, 504b.

Upon reception of the first ACK from any Node-B 504a, 504b in the RNC 506, the RNC 506 transmits ACK decision to all Node-Bs 504a, 504b. In the case that all Node-Bs 504a, 504b derive a NACK, it takes some time to wait for all Node-Bs 504a, 504b to provide the CRC results. Therefore, optionally the RNC 506 may set a timer waiting for all Node-B's responses and if the timer expires the RNC 506 transmits a NACK to all Node-Bs 504a, 504b.

In accordance with the second alternative, a single logical channel between two Node-Bs 504a, 504b via an RNC 506 is established. The RNC 506 receives CRC results from one Node-B 504b and just forwards it to another Node-B 504a without processing it. This process is fast since the signaling is just routed between Node-Bs 504a, 504b without processing at the RNC 506. Therefore, it avoids the processing delay and protocol delay at the RNC 506. Each Node-B 504a, 504b derives the final ACK/NACK decision based on the collected CRC results from all the involved Node-Bs 504a, 504b in the active set. If there is at least one ACK from any Node-B, a final ACK decision will be made at each Node-B 504a, 504b. Otherwise, a final decision of NACK will be made by the Node-B 504a, 504b. As stated above, each Node-B 504a,

6

504b generates an ACK decision upon reception of the first ACK from any Node-B 504a, 504b. The Node-Bs 504a, 504b may set a timer waiting for an ACK from other Node-Bs 504a, 504b, and if the Node-Bs 504a, 504b do not receive any ACK before the expiration of the timer, the Node-Bs 504a, 504b generates a NACK decision.

The streamlined connection 510a, 510b between Node-Bs 504a, 504b and an RNC 506 may be implemented in any embodiment of the present invention described herein.

With reference to FIGS. 6 and 7, signaling of the ACK/NACK decision between an RNC and Node-Bs is explained. FIG. 6 shows a system 600 whereby a non-primary Node-B 604b has the same controlling RNC (CRNC) 606 as the primary Node-B 604a. In this case, the CRNC 606 sends an asynchronous ACK to the WTRU 602 via the primary Node-B 604a.

FIG. 7 shows a system 700 whereby a non-primary Node-B 704b has a different CRNC 706b from a CRNC 706a of the primary Node-B 704a. In this case, a serving RNC (SRNC) 707 sends an asynchronous ACK to the WTRU 702 via the primary Node-B 704a.

FIGS. 2A and 2B are diagrams of a system 200 and a process 250 of the second embodiment of the present invention. In this second embodiment, incremental combining is performed in each Node-B 204a, 204b whereby each Node-B 204a, 204b combines a previous transmission of a data packet with a retransmission of the same data packet with or without increased redundancy from the WTRU 202.

A WTRU 202 establishes connections with at least two cells controlled by different Node-Bs 204a, 204b for soft handover, and data packets transmitted from the WTRU 202 are received and processed separately by the Node-Bs 204a, 204b (step 252). Each Node-B 204a, 204b performs an error check on the data packet and generates a CRC result (step 254). Each Node-B 204a, 204b transmits the CRC result to the RNC 206. Simultaneously, each Node-B 204a, 204b transmits the CRC result to the WTRU 202 as well (step 256). The WTRU 202 makes a determination regarding whether there is at least one ACK received from Node-Bs 204a, 204b (step 258). The WTRU 202 may receive both ACK and NACK signals from the Node-Bs 204a, 204b. If the WTRU 202 receives no ACK, it schedules retransmission of the data packet (step 264). The Node-Bs 204a, 204b perform incremental combining of the retransmission with the previous transmission. If the WTRU 202 receives at least one ACK from any Node-B 204a, 204b, the WTRU 202 transmits the next data packet (step 262).

The RNC 206 also makes an ACK/NACK decision based on collected ACK/NACK signals from the Node-Bs 204a, 204b (step 260). The RNC 206 generates and transmits an ACK decision (step 268) if the RNC 206 receives at least one ACK from the Node-Bs 204a, 204b. Otherwise, the RNC 206 generates and transmits a NACK decision to the Node-Bs 204a, 204b (step 270). The ACK/NACK decision is transmitted to the Node-Bs 204a, 204b. Each Node-B 204a, 204b refreshes its soft buffer once it receives ACK decision from the RNC 206 (step 272). With this scheme, soft buffer corruption is eliminated.

FIGS. 3A and 3B are diagrams of a system 300 and a process 350 of a third embodiment of the present invention. The WTRU 302 establishes at least two connections with cells controlled by different Node-Bs 304a, 304b for soft handover. Data packets transmitted from the WTRU 302 are received and processed separately by at least two Node-Bs 304a, 304b during soft handover (step 352). Each Node-B 304a, 304b performs an error check on the data packet and generates an ACK/NACK result based on the error check on

the received data packet (step 354). A Node-B coordinator 308 is provided to coordinate among Node-Bs 304a, 304b, and between Node-Bs 304a, 304b and the RNC 306. Each Node-B 304a, 304b sends the ACK/NACK result to the Node-B coordinator 308 (step 356). In this embodiment, a final decision on whether an ACK or a NACK is transmitted to the WTRU 302 is made by the Node-B coordinator 308. It is determined whether any of the involved Node-Bs 304a, 304b generates an ACK as a result of the error check (step 358). If so, the Node-B coordinator 308 commands each of all the involved Node-Bs 304a, 304b to flush out the corresponding soft buffer and to prepare for a new transmission, regardless of the result of the error check derived at each Node-B 304a, 304b (step 360). In response, each Node-B 304a, 304b sends an ACK to the WTRU 302 and refreshes its soft buffer (step 362).

If the results of the error check from all Node-Bs 304a, 304b fail, (i.e. all of the Node-Bs 304a, 304b generate NACKs) or a response timer Node-B coordinator expires, the Node-B coordinator 308 informs all of the Node-Bs 304a, 304b that they failed to successfully decode the transmitted data packet and that they should prepare for retransmission of the data packet (step 364). In response, the Node-Bs 304a, 304b send a NACK to the WTRU 302 (step 366).

FIGS. 4A and 4B are diagrams of a system 400 and a process 450 of a fourth embodiment of the present invention. For soft handover, a WTRU 402 establishes a separate connection with at least two cells controlled by different Node-Bs 404a, 404b in an active set. Data packets transmitted from the WTRU 402 are received and processed separately by the Node-Bs 404a, 404b during soft handover (step 452). Each Node-B 404a, 404b performs an error check on the received data packets and generates an indication of success or failure in decoding the data packet (step 454).

Each Node-B 404a, 404b transmits a CRC result to the RNC 406 (step 456). If the Node-B 404a, 404b succeeds in decoding the data packet, the Node-B 404a, 404b sends an ACK to the RNC 406 along with the data packet. If the Node-B 404a, 404b fails in decoding the data packet, the Node-B 404a, 404b sends a NACK to the RNC 406. An ACK and NACK may be sent with each data block within Iub/Iur frame protocols between Node-Bs 404a, 404b and the RNC 406. The RNC 406 makes a final ACK/NACK decision regarding the transmission of the data packet from the error check results conducted by the Node-Bs 404a, 404b (step 458). The RNC 406 makes an ACK decision if the RNC 406 receives at least one ACK from the Node-Bs 404a, 404b. Otherwise the RNC 406 makes a NACK decision. The ACK or NACK decision made by the RNC 406 is then transmitted back to the Node-Bs 404a, 404b at steps 460 and 464, respectively. Each Node-B 404a, 404b clears its buffer upon receipt of the ACK decision from the RNC 406. All Node-Bs 404a, 404b transmit the same ACK or NACK signal made by the RNC 406 to the WTRU 402 regardless of the CRC result that each Node-B 404a, 404b individually derived from the data packet (steps 462 and 466). In this case, the WTRU 402 may apply maximum ratio combining (MRC) to the received ACK/NACK feedback signals from the Node-Bs 404a, 404b.

The soft buffer in each Node-B 404a, 404b is managed according to the ACK/NACK decision made by the RNC 406, regardless of the associated error check result derived by the Node-Bs 404a, 404b. Consequently, the fourth embodiment of the present invention allows the RNC 406 to align the soft buffer status in each Node-B 404a, 404b. Additionally, the WTRU 402 can benefit from the soft handover gain for the ACK/NACK signaling, since identical ACK/NACK signaling is transmitted by all Node-Bs 404a, 404b. As such, the WTRU

402 may perform macro diversity combining (maximum ratio combining) for ACK/NACK signaling, since the ACK/NACK signals transmitted back to the WTRU 402 from all the involved Node-Bs 404a, 404b are identical.

A fifth embodiment of the present invention will be explained with reference to FIG. 2A. The fifth embodiment is similar to the second embodiment, except that Node-Bs 204a, 204b do not perform incremental combining during soft handover. A WTRU 202 establishes connections with at least two cells controlled by different Node-Bs 204a, 204b for soft handover. Data packets transmitted from the WTRU 202 are received and processed separately by at least two Node-Bs 204a, 204b during soft handover. Each Node-B 204a, 204b performs an error check on the data packet and transmits an ACK/NACK signal to the WTRU 202. The Node-Bs 204a, 204b send ACKs along with an identification of transmission to an RNC 206. The WTRU 202 sends a sequence of data packets and simultaneously looks at the MAC level for an ACK from any Node-B 204a, 204b when it is in soft handover, and only from the current Node-B when it is not in soft handover. This method causes retransmission when either the time-out threshold is exceeded for an ACK or an out-of-sequence is reported by all cells. Alternatively, this embodiment may be implemented with respect to other embodiments including the first embodiment shown in FIG. 1A.

FIGS. 8A and 8B are diagrams of a system 800 and a process 850 for softer handover in accordance with the present invention. During softer handover, the WTRU 802 establishes connections with more than one cell 808 which are controlled by the same Node-B 804 (step 852). EU transmissions from the WTRU 802 are processed by each cell 808 independently (step 854), and each cell 808 transmissions received from the WTRU 802 are processed by the Node-B 804 controlling these cells (step 856). There are two alternatives with respect to incremental combining of transmissions transmitted from the WTRU 802.

In accordance with the first alternative, the Node-B 804 receives data packets from all the involved cells 808 and combines them using a technique, such as maximum ratio combining, before performing error check on the data packet. The resulting combined data packet is error checked at the Node-B 804.

In accordance with the second alternative, each cell 808 processes the data packet individually determining error check on the data packet received from the WTRU 802. The Node-B 804 accepts the data packet that the error check has passed in any of the cells 808 within the active set.

In downlink, the Node-B 804 sends messages including ACK/NACK to the WTRU 802 via all the involved cells 808 (step 858). The WTRU 802 needs to monitor all channels, preferably shared channels, from the involved cells 808 to detect downlink messages. The number of shared channels that the WTRU 802 should monitor from each cell 808 may be limited, such as up to 4 channels.

One of the cells 808 may be designated as a primary cell 808a, while other cells are designated as non-primary cells 808b. The primary cell 808a sends a message on any of the downlink shared channels allocated to the WTRU 802. The message carries a shared channel indicator for non-primary cells 808b. The non-primary cells 808b send messages on the channel indicated by the shared channel indicator. In order to implement this scheme, there is a timing offset between the transmission of the shared channel indicator from the primary cell 808a and the transmission of messages from non-primary cells 808b. The WTRU 802 first monitors all shared channels from the primary cell 808a. Once the WTRU 802 detects that one of the shared channels carry messages to the WTRU 802,

the WTRU 802 reads shared channel indicator along with the downlink messages from the primary cell 808a. Then, the WTRU 802 receives messages from the non-primary cells 808b indicated by the shared channel indicator. With this scheme, it is possible to lower the number of channels that the WTRU 802 should monitor. The WTRU 802 then combines the messages received from all the involved cells 808 using a technique, such as maximum ratio combining.

Alternatively, for the DL, only the primary cell 808a may transmit messages to the WTRU 802. The Node-B 804 transmits downlink messages via the primary cell 808a, while all non-primary cells 808b switch off the downlink signaling to the WTRU 802. With this scheme, the WTRU 802 receive processing is simplified and downlink interference is reduced.

FIG. 9 is a diagram of a system 900 for transferring WTRU-specific information to support EU operation 912 in accordance with the present invention. Initially, an RNC 906 obtains WTRU-specific information from a WTRU 902 using RRC messaging 908 at the initial connection. Then, the WTRU-specific information is forwarded from the RNC 906 to a Node-B 904 to be used in scheduling EU transmissions for the WTRU 902. The transfer of the information from the RNC 906 to the Node-B 904 is via an Iub interface 910, and an Iur interface if an SRNC is not the same as a CRNC. A new signaling mechanism may be utilized to transfer the information from the RNC 906 to the Node-B 904, or alternatively, the existing mechanisms over Iur and Iub interfaces may be modified in order for the RNC 906 to forward relevant WTRU-specific information to the Node-B 904.

FIG. 10 is a diagram of a system 1000 for transferring information among network entities during soft handover in accordance with the present invention. During EU operation, if a WTRU 1002 needs to change the serving cell or the serving Node-B, a softer or soft handover procedure is initiated. Hereinafter, for simplicity, the present invention will be explained only with respect to a soft handover. During soft handover, some information should be communicated between network entities to support EU operation. The information includes, but is not limited to, information related to an active set, information regarding a primary Node-B if the system so designates, EU scheduling/rate information, and ACK/NACK status information.

An RNC 1006 maintains an active set of cells for handover. The RNC 1006 selects and removes cells in the active set based on measurements reported from Node-Bs 1004a, 1004b and the WTRU 1002 and on available radio resources. Once the RNC 1006 selects cells for the active set, the RNC 1006 sends messages to the Node-Bs 1004a, 1004b and the WTRU 1002 to inform the selected cells for the active set to support soft handover for EU. The RNC 1006 also sends messages to update the active set each time the RNC 1006 adds or removes a cell in the active set. The messages may be transmitted using existing RRC and NBAP/RNSAP active set management procedures or new procedures.

Either the RNC 1006 or the Node-Bs 1004a, 1004b and the WTRU 1002 may designate one Node-B as a primary Node-B 1004a and other Node-Bs in the active set as non-primary Node-Bs 1004b during soft handover. The selection of the primary Node-B 1004a is based on UL performance measured and reported by each Node-B 1004a, 1004b and/or DL performance measured and reported by the WTRU 1002.

During soft handover, only the primary Node-B 1004a performs scheduling and assigning radio resources to the WTRU 1002. The primary Node-B 1004a informs the RNC 1006 of scheduled EU transmissions via Iub NBAP signaling or within the EU frame protocol. The RNC 1006 then informs

non-primary Node-Bs 1004b of the allocation of radio resources for EU and routing of received data. This is also signaled over NBAP or within the EU frame protocol. Alternatively, non-primary Node-Bs 1004b may be informed by Iub NBAP procedures of sets of EU physical channels for the period each cell is within the active subset. Each non-primary Node-B 1004b within the active set continuously receives these channels independent of radio resources allocation scheduled by the primary Node-B 1004a.

Although the features and elements of the present invention are described in the preferred embodiments in particular combinations, each feature or element can be used alone without the other features and elements of the preferred embodiments or in various combinations with or without other features and elements of the present invention.

What is claimed is:

1. A method for operating hybrid automatic repeat request (H-ARQ) in a wireless communications network, the method comprising:

receiving a data packet from a wireless transmit/receive unit (WTRU) via an enhanced uplink (EU) channel;

decoding the data packet;

sending an acknowledgement (ACK) to a radio network controller (RNC) on a condition that the data packet is successfully decoded;

receiving an ACK/non-acknowledgement (NACK) decision from the RNC, an ACK decision being made on a condition that there is at least one ACK from Node-Bs and a NACK decision being made on a condition that there is no ACK from the Node-Bs; and

forwarding the ACK/NACK decision to the WTRU.

2. The method of claim 1 further comprising:

flushing a soft buffer on a condition that an ACK decision is received from the RNC.

3. The method of claim 1 wherein one of the Node-Bs is designated as a primary Node-B and only the primary Node-B performs soft combining.

4. The method of claim 3 wherein non-primary Node-Bs perform only automatic repeat request (ARQ).

5. The method of claim 3 wherein non-primary Node-Bs transmit only correctly decoded data packets to the RNC.

6. The method of claim 1 wherein one of the Node-Bs is designated as a primary Node-B and both the primary Node-B and non-primary Node-Bs perform soft combining and each Node-B transmits a data packet along with identification of transmission and H-ARQ process and WTRU identity.

7. A method for operating hybrid automatic repeat request (H-ARQ) in a wireless communications network, the method comprising:

receiving a data packet from a wireless transmit/receive unit (WTRU) via an enhanced uplink (EU) channel;

decoding the data packet;

sending an acknowledgement (ACK) both to the WTRU and a radio network controller (RNC) on a condition that the data packet is successfully decoded; and

receiving an ACK/non-acknowledgement (NACK) decision from the RNC, an ACK decision being made on a condition that there is at least one ACK from Node-Bs and a NACK decision being made on a condition that there is no ACK from the Node-Bs.

8. The method of claim 7 further comprising:

flushing a soft buffer when an ACK decision is received from the RNC.

9. A Node-B for operating hybrid automatic repeat request (H-ARQ) in a wireless communications network, the Node-B comprising:

11

a receiver configured to receive a data packet from a wireless transmit/receive unit (WTRU) via an enhanced uplink (EU) channel;

a decoder configured to decode the data packet; and
 an H-ARQ entity configured to send a positive acknowledgement (ACK) to a radio network controller (RNC) on a condition that the data packet is successfully decoded and receive an ACK/negative acknowledgement (NACK) decision from the RNC and forward the ACK/NACK decision to the WTRU, wherein an ACK decision being made on a condition that there is at least one ACK from Node-Bs and a NACK decision being made on a condition that there is no ACK from the Node-Bs.

10. The Node-B of claim 9 further comprising:

a soft buffer configured to store the data packet, the soft buffer being flushed on a condition that an ACK decision is received from the RNC.

11. The Node-B of claim 9 wherein one of the Node-Bs is designated as a primary Node-B and only the primary Node-B performs soft combining.

12. The Node-B of claim 11 wherein the non-primary Node-Bs perform only automatic repeat request (ARQ).

13. The Node-B of claim 12 wherein the non-primary Node-Bs transmit only correctly decoded data packets to the RNC.

14. A Node-B for operating hybrid automatic repeat request (H-ARQ) in a wireless communications network, the Node-B comprising:

a receiver configured to receive a data packet from a wireless transmit/receive unit (WTRU) via an enhanced uplink (EU) channel;

a decoder configured to decode the data packet; and
 an H-ARQ entity configured to send an acknowledgement (ACK) both to the WTRU and a radio network controller (RNC) on a condition that the data packet is successfully decoded and receive an ACK/negative acknowledgement (NACK) decision from the RNC, an ACK decision being made on a condition that there is at least one ACK from Node-Bs and a NACK decision being made on a condition that there is no ACK from the Node-Bs.

15. The Node-B of claim 14 wherein one of the Node-Bs is designated as a primary Node-B and both the primary Node-B and the non-primary Node-Bs perform soft combining and each Node-B transmits a data packet along with identification of transmission and H-ARQ process and WTRU identity.

16. A Node-B for operating hybrid automatic repeat request (H-ARQ) in a wireless communications network, the Node-B comprising:

a receiver configured to receive a data packet from a wireless transmit/receive unit (WTRU) via an enhanced uplink (EU) channel;

a decoder configured to decode the data packet; and
 an H-ARQ entity configured to send an acknowledgement (ACK) to a Node-B coordinator on a condition that the data packet is successfully decoded, receive an ACK/negative acknowledgement (NACK) decision from the Node-B coordinator, and forward the ACK/NACK decision to the WTRU, wherein an ACK decision is made on

12

a condition that there is at least one ACK from Node-Bs and a NACK decision is made on a condition that there is no ACK from the Node-Bs.

17. A method for operating hybrid automatic repeat request (H-ARQ), implemented in a Node-B, in a wireless communications network, the method comprising:

receiving a data packet via each of at least two cells controlled by the Node B, wherein each cell received its respective data packet from a wireless transmit/receive unit (WTRU) via an enhanced uplink (EU) channel;
 combining the each received data packet into a combined data packet;

decoding the combined data packet;

sending an acknowledgement (ACK) to the WTRU on a condition that the combined data packet is successfully decoded and a non-acknowledgement (NACK) on a condition that the combined data packet is not successfully decoded, wherein one cell is designated as a primary cell, and other cells are designated as a non-primary cell; and

transmitting downlink messages to the WTRU using the primary cell during softer handover.

18. The method of claim 17 wherein the ACK/NACK is signaled via a downlink channel shared by a plurality of WTRUs.

19. The method of claim 18 further comprising receiving a shared channel indicator indicating channels in which the WTRU is allowed to receive messages from the non-primary cells.

20. A Node-B for operating hybrid automatic repeat request (H-ARQ), in a wireless communications network, the Node-B comprising:

a H-ARQ process configured to perform H-ARQ operation for a wireless transmit/receive unit (WTRU);

a receiver configured to receive a data packet via each of at least two cells controlled by the Node-B wherein each cell received its respective data packet from the WTRU via an enhanced uplink (EU) channel;

a decoder configured to combine the each data packet into a combined data packet and decode the combined data packet,

wherein the H-ARQ process sends an acknowledgement (ACK) to the WTRU on a condition that the combined data packet is successfully decoded and sends a non-acknowledgement (NACK) to the WTRU on a condition that the combined data packet is not successfully decoded, wherein one cell is designated as a primary cell and other cells are designated as a non-primary cell; and
 a transmitter configured to transmit downlink messages to the WTRU using the primary cell during softer handover.

21. The Node-B of claim 20 wherein the ACK/NACK is signaled via a downlink channel shared by a plurality of WTRUs.

22. The Node-B of claim 21 wherein a shared channel indicator is sent via the primary cell indicating channels in which the WTRU is allowed to receive messages from the non-primary cells.

* * * * *

UNITED STATES PATENT AND TRADEMARK OFFICE
CERTIFICATE OF CORRECTION

PATENT NO. : 8,023,463 B2
APPLICATION NO. : 10/925426
DATED : September 20, 2011
INVENTOR(S) : Dick et al.

Page 1 of 1

It is certified that error appears in the above-identified patent and that said Letters Patent is hereby corrected as shown below:

IN THE SPECIFICATION

At column 3, line 2, after “final ACK/NACK”, delete “decision” and insert --decisions--.

At column 3, line 62, after “particular” delete “WTRUs” and insert --WTRU’s--.

At column 5, line 28, after “RNC 506 and”, delete “an”.

At column 6, line 6, before “a NACK decision.”, delete “generates” and insert --generate--.

At column 6, line 36, after “each Node-B”, delete “2041” and insert --204a--.

At column 7, line 4, after “304a”, delete “604b” and insert --304b--.

Signed and Sealed this
Fifteenth Day of May, 2012

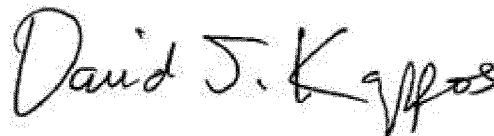

David J. Kappos
Director of the United States Patent and Trademark Office