

(12) **United States Patent**
Merritt et al.

(10) **Patent No.:** **US 11,844,921 B2**
(45) **Date of Patent:** ***Dec. 19, 2023**

(54) **HEMOSTASIS VALVES AND METHODS OF USE**

(71) Applicant: **Inari Medical, Inc.**, Irvine, CA (US)

(72) Inventors: **Benjamin E. Merritt**, San Clemente, CA (US); **John C. Thress**, Capistrano Beach, CA (US); **Paul Lubock**, Monarch Beach, CA (US)

(73) Assignee: **Inari Medical, Inc.**, Irvine, CA (US)

(*) Notice: Subject to any disclaimer, the term of this patent is extended or adjusted under 35 U.S.C. 154(b) by 496 days.

This patent is subject to a terminal disclaimer.

(21) Appl. No.: **17/226,318**

(22) Filed: **Apr. 9, 2021**

(65) **Prior Publication Data**

US 2021/0290925 A1 Sep. 23, 2021

Related U.S. Application Data

(63) Continuation of application No. 16/117,519, filed on Aug. 30, 2018, now Pat. No. 11,000,682.
(Continued)

(51) **Int. Cl.**

A61M 39/06 (2006.01)
A61B 17/3207 (2006.01)

(52) **U.S. Cl.**

CPC **A61M 39/0613** (2013.01); **A61B 17/3207** (2013.01); **A61M 2039/062** (2013.01); **A61M 2039/0673** (2013.01)

(58) **Field of Classification Search**

CPC **A61M 2039/0673**; **A61M 39/0613**; **A61M 2039/062**; **A61M 2039/0626**; **F16K 7/06**; **F16K 7/04**; **F16K 7/08**; **F16K 7/02**
See application file for complete search history.

(56) **References Cited**

U.S. PATENT DOCUMENTS

1,101,890 A 6/1914 Tunstead
2,846,179 A * 8/1958 Monckton F16K 7/04
222/507

(Continued)

FOREIGN PATENT DOCUMENTS

AU 2015210338 8/2015
CN 102186427 9/2011

(Continued)

OTHER PUBLICATIONS

European Patent Application No. 13838945.7, Extended European Search Report, 9 pages, dated Apr. 15, 2016.

(Continued)

Primary Examiner — Quynh-Nhu H. Vu

(74) *Attorney, Agent, or Firm* — Perkins Coie LLP

(57) **ABSTRACT**

Devices, systems, and methods for sealing medical devices, particularly during intravascular access, are disclosed herein. Some aspects relate to a hemostatic valve for sealing a wide range of medical devices, such as catheters, wires, embolectomy systems. The valve can include an elongate member having a first end, a second end, and a central lumen extending therebetween. A reinforcement structure extends along at least a portion of the elongate member and is coupled to the elongate member. A shell defining a first aperture and a second aperture may be included, which first and second apertures can be fluidly coupled by the elongate member. A tensioning mechanism is coupled to the shell and to the elongate member, the tensioning mechanism can be moveable between a first configuration wherein the tensioning mechanism is collapsed and the central lumen is sealed and a second configuration wherein the central lumen is open.

26 Claims, 10 Drawing Sheets

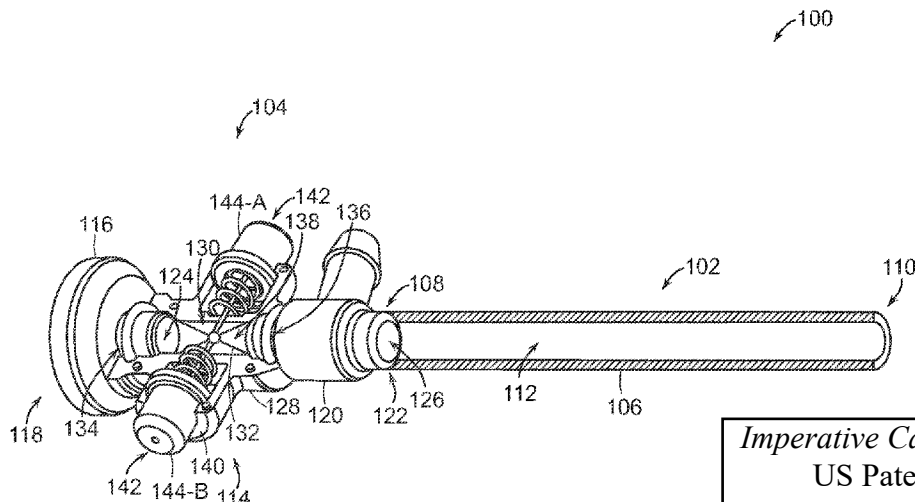

Imperative Care v. Inari Medical
US Patent 11,844,921
Imperative Care Ex. 1001

Related U.S. Application Data					
		5,443,443	A	8/1995	Shiber
		5,456,667	A	10/1995	Ham et al.
(60)	Provisional application No. 62/554,931, filed on Sep. 6, 2017.	5,476,450	A	12/1995	Ruggio
		5,484,418	A *	1/1996	Quiachon A61M 25/005 604/167.03
(56)	References Cited	5,490,859	A	2/1996	Mische et al.
		5,496,365	A	3/1996	Sgro
		5,527,326	A	6/1996	Hermann et al.
		5,549,626	A	8/1996	Miller et al.
		5,591,137	A	1/1997	Stevens
		5,639,276	A	6/1997	Weinstock et al.
		5,653,684	A	8/1997	Laptewicz et al.
		5,662,703	A	9/1997	Yurek et al.
		5,746,758	A	5/1998	Nordgren et al.
		5,749,858	A	5/1998	Cramer
		5,769,816	A	6/1998	Barbut et al.
		5,782,817	A	7/1998	Franzel et al.
		5,800,457	A	9/1998	Gelbfish
		5,827,229	A	10/1998	Auth et al.
		5,846,251	A	12/1998	Hart
		5,860,938	A	1/1999	Lafontaine et al.
		5,873,866	A	2/1999	Kondo et al.
		5,873,882	A	2/1999	Straub et al.
		5,876,414	A	3/1999	Straub
		5,895,406	A	4/1999	Gray et al.
		5,908,435	A	6/1999	Samuels
		5,911,710	A	6/1999	Barry et al.
		5,911,733	A	6/1999	Parodi
		5,911,754	A	6/1999	Kanesaka et al.
		5,941,869	A	8/1999	Patterson et al.
		5,947,985	A	9/1999	Imram
		5,954,737	A	9/1999	Lee
		5,971,938	A	10/1999	Hart et al.
		5,971,958	A	10/1999	Zhang
		5,972,019	A	10/1999	Engelson et al.
		5,974,938	A	11/1999	Lloyd
		5,989,233	A	11/1999	Yoon
		5,993,483	A	11/1999	Gianotti
		6,030,397	A	2/2000	Moneti et al.
		6,059,814	A	5/2000	Ladd
		6,066,158	A	5/2000	Engelson et al.
		6,068,645	A	5/2000	Tu
		6,126,635	A	10/2000	Simpson et al.
		6,142,987	A	11/2000	Tsugita
		6,146,396	A	11/2000	Konya et al.
		6,146,403	A	11/2000	St. Germain
		6,152,144	A	11/2000	Lesh et al.
		6,152,946	A	11/2000	Broome et al.
		6,156,055	A	12/2000	Ravenscroft
		6,159,230	A	12/2000	Samuels
		6,165,196	A	12/2000	Stack et al.
		6,168,579	B1	1/2001	Tsugita
		6,179,859	B1	1/2001	Bates et al.
		6,221,006	B1	4/2001	Dubrul et al.
		6,228,060	B1	5/2001	Howell
		6,238,412	B1	5/2001	Dubrul et al.
		6,245,078	B1	6/2001	Ouchi
		6,245,089	B1	6/2001	Daniel et al.
		6,254,571	B1	7/2001	Hart
		6,258,115	B1	7/2001	Dubrul
		6,264,663	B1	7/2001	Cano
		6,306,163	B1	10/2001	Fitz
		6,322,572	B1	11/2001	Lee
		6,350,271	B1	2/2002	Kurz et al.
		6,361,545	B1	3/2002	Macoviak et al.
		6,364,895	B1	4/2002	Greenhalgh
		6,368,339	B1	4/2002	Amplatz
		6,383,205	B1	5/2002	Samson et al.
		6,402,771	B1	6/2002	Palmer et al.
		6,413,235	B1	7/2002	Parodi
		6,423,032	B2	7/2002	Parodi
		6,432,122	B1	8/2002	Gilson et al.
		6,451,036	B1	9/2002	Heitzmann et al.
		6,458,103	B1	10/2002	Albert et al.
		6,475,236	B1	11/2002	Roubin et al.
		6,485,502	B2	11/2002	Don Michael
		6,508,782	B1	1/2003	Evans et al.
		6,511,492	B1	1/2003	Rosenbluth et al.
		6,514,273	B1	2/2003	Voss et al.

(56)

References Cited

U.S. PATENT DOCUMENTS

6,530,923 B1	3/2003	Dubrul et al.	7,713,282 B2	5/2010	Frazier et al.	
6,530,935 B2	3/2003	Wensel et al.	7,722,641 B2	5/2010	van der Burg et al.	
6,540,722 B1	4/2003	Boyle et al.	7,763,010 B2	7/2010	Evans et al.	
6,544,276 B1	4/2003	Azizi	7,766,934 B2	8/2010	Pal et al.	
6,544,278 B1	4/2003	Vrba et al.	7,775,501 B2*	8/2010	Kees	F16K 7/065 251/5
6,544,279 B1	4/2003	Hopkins et al.	7,780,696 B2	8/2010	Daniel et al.	
6,551,342 B1	4/2003	Shen et al.	7,815,608 B2	10/2010	Schafersman et al.	
6,564,828 B1	5/2003	Ishida	7,905,877 B1	3/2011	Oscar et al.	
6,569,181 B1	5/2003	Burns	7,905,896 B2	3/2011	Straub	
6,575,995 B1	6/2003	Huter et al.	7,938,809 B2	5/2011	Lampropoulos et al.	
6,589,263 B1	7/2003	Hopkins et al.	7,938,820 B2	5/2011	Webster et al.	
6,596,011 B2	7/2003	Johnson et al.	7,967,790 B2	6/2011	Whiting et al.	
6,602,271 B2	8/2003	Adams et al.	7,976,511 B2	7/2011	Fotjik	
6,605,074 B2	8/2003	Zadno-Azizi et al.	7,993,302 B2	8/2011	Hebert et al.	
6,605,102 B1	8/2003	Mazzocchi et al.	7,993,363 B2	8/2011	Demond et al.	
6,610,077 B1	8/2003	Hancock et al.	8,021,351 B2	9/2011	Boldenow et al.	
6,620,148 B1	9/2003	Tsugita	8,043,313 B2	10/2011	Krolik et al.	
6,620,179 B2	9/2003	Brook et al.	8,052,640 B2	11/2011	Fiorella et al.	
6,620,182 B1	9/2003	Khosravi et al.	8,057,496 B2	11/2011	Fischer, Jr.	
6,623,460 B1	9/2003	Heck	8,057,497 B1	11/2011	Raju et al.	
6,635,068 B1	10/2003	Dubrul et al.	8,066,757 B2	11/2011	Ferrera et al.	
6,645,222 B1	11/2003	Parodi et al.	8,070,694 B2	12/2011	Galdonik et al.	
6,660,013 B2	12/2003	Rabiner et al.	8,070,769 B2	12/2011	Broome	
6,660,014 B2	12/2003	Demarais et al.	8,070,791 B2	12/2011	Ferrera et al.	
6,663,650 B2	12/2003	Sepetka et al.	8,075,510 B2	12/2011	Aklog et al.	
6,692,504 B2	2/2004	Kurz et al.	8,080,032 B2	12/2011	van der Burg et al.	
6,699,260 B2	3/2004	Dubrul et al.	8,088,140 B2	1/2012	Ferrera et al.	
6,702,830 B1	3/2004	Demarais et al.	8,092,486 B2	1/2012	Berrada et al.	
6,719,717 B1	4/2004	Johnson et al.	8,100,935 B2	1/2012	Rosenbluth et al.	
6,755,847 B2	6/2004	Eskuri	8,109,962 B2	2/2012	Pal	
6,767,353 B1	7/2004	Shiber	8,118,829 B2	2/2012	Carrison et al.	
6,790,204 B2	9/2004	Zadno-azizi et al.	8,197,493 B2	6/2012	Ferrera et al.	
6,800,080 B1	10/2004	Bates	8,246,641 B2	8/2012	Osborne et al.	
6,818,006 B2	11/2004	Douk et al.	8,261,648 B1	9/2012	Marchand et al.	
6,824,545 B2	11/2004	Sepetka et al.	8,267,897 B2*	9/2012	Wells	A61B 17/3498 604/167.05
6,824,550 B1	11/2004	Noriega et al.	8,298,257 B2	10/2012	Sepetka et al.	
6,824,553 B1	11/2004	Gene et al.	8,317,748 B2	11/2012	Fiorella et al.	
6,830,561 B2	12/2004	Jansen et al.	8,337,450 B2	12/2012	Fotjik	
6,846,029 B1	1/2005	Ragner et al.	RE43,902 E	1/2013	Hopkins et al.	
6,902,540 B2	6/2005	Dorros et al.	8,343,167 B2	1/2013	Henson	
6,939,361 B1	9/2005	Kleshinski	8,357,178 B2	1/2013	Grandfield et al.	
6,942,682 B2	9/2005	Vrba et al.	8,361,104 B2	1/2013	Jones et al.	
6,945,977 B2	9/2005	Demarais et al.	8,409,215 B2	4/2013	Sepetka et al.	
6,960,189 B2	11/2005	Bates et al.	8,480,708 B2	7/2013	Kassab et al.	
6,960,222 B2	11/2005	Vo et al.	8,486,105 B2	7/2013	Demond et al.	
7,004,931 B2	2/2006	Hogendijk	8,491,539 B2	7/2013	Fotjik	
7,004,954 B1	2/2006	Voss et al.	8,512,352 B2	8/2013	Martin	
7,036,707 B2	5/2006	Aota et al.	8,523,897 B2	9/2013	van der Burg et al.	
7,041,084 B2	5/2006	Fotjik	8,535,283 B2	9/2013	Heaton et al.	
7,052,500 B2	5/2006	Bashiri et al.	8,535,334 B2	9/2013	Martin	
7,056,328 B2	6/2006	Arnott	8,535,343 B2	9/2013	van der Burg et al.	
7,063,707 B2	6/2006	Bose et al.	8,545,526 B2	10/2013	Martin et al.	
7,069,835 B2	7/2006	Nishri et al.	8,568,432 B2	10/2013	Straub	
7,094,249 B1	8/2006	Thomas et al.	8,568,465 B2	10/2013	Freudenthal et al.	
7,122,034 B2	10/2006	Belhe et al.	8,574,262 B2	11/2013	Ferrera et al.	
7,128,073 B1	10/2006	van der Burg et al.	8,579,915 B2	11/2013	French et al.	
7,152,605 B2	12/2006	Khairkhahan et al.	8,585,713 B2	11/2013	Ferrera et al.	
7,179,273 B1	2/2007	Palmer et al.	8,608,754 B2	12/2013	Wensel et al.	
7,223,253 B2	5/2007	Hogendijk	8,647,367 B2	2/2014	Kassab et al.	
7,232,432 B2	6/2007	Fulton, III et al.	8,657,867 B2	2/2014	Dorn et al.	
7,244,243 B2	7/2007	Lary	8,696,622 B2	4/2014	Fiorella et al.	
7,285,126 B2	10/2007	Sepetka et al.	8,715,314 B1	5/2014	Janardhan et al.	
7,300,458 B2	11/2007	Henkes et al.	8,721,714 B2	5/2014	Kelley	
7,306,618 B2	12/2007	Demond et al.	8,753,322 B2	6/2014	Hu et al.	
7,320,698 B2	1/2008	Eskuri	8,771,289 B2	7/2014	Mohluddin et al.	
7,323,002 B2	1/2008	Johnson et al.	8,777,893 B2	7/2014	Malewicz	
7,331,980 B2	2/2008	Dubrul et al.	8,784,441 B2	7/2014	Rosenbluth et al.	
7,481,805 B2	1/2009	Magnusson	8,784,442 B2	7/2014	Jones et al.	
7,534,234 B2	5/2009	Fotjik	8,784,469 B2	7/2014	Kassab	
7,578,830 B2	8/2009	Kusleika et al.	8,795,305 B2	8/2014	Martin et al.	
7,621,870 B2	11/2009	Berrada et al.	8,795,345 B2	8/2014	Grandfield et al.	
7,674,247 B2	3/2010	Fotjik	8,801,748 B2	8/2014	Martin	
7,678,131 B2	3/2010	Muller	8,808,259 B2	8/2014	Walton et al.	
7,691,121 B2	4/2010	Rosenbluth et al.	8,814,927 B2	8/2014	Shin et al.	
7,695,458 B2	4/2010	Belley et al.	8,820,207 B2	9/2014	Marchand et al.	
			8,826,791 B2	9/2014	Thompson et al.	
			8,828,044 B2	9/2014	Aggerholm et al.	

(56)

References Cited

U.S. PATENT DOCUMENTS

8,833,224 B2	9/2014	Thompson et al.	10,335,186 B2	7/2019	Rosenbluth et al.
8,834,519 B2	9/2014	van der Burg et al.	10,342,571 B2	7/2019	Marchand et al.
8,845,621 B2	9/2014	Fotjik	10,349,960 B2	7/2019	Quick
8,852,226 B2	10/2014	Gilson et al.	10,383,644 B2	8/2019	Molaei et al.
8,939,991 B2	1/2015	Krolik et al.	10,384,034 B2	8/2019	Carrison et al.
8,945,143 B2	2/2015	Ferrera et al.	10,456,555 B2	10/2019	Carrison et al.
8,945,172 B2	2/2015	Ferrera et al.	10,478,535 B2	11/2019	Ogle
8,956,384 B2	2/2015	Berrada et al.	10,485,952 B2	11/2019	Carrison et al.
8,992,504 B2	3/2015	Castella et al.	10,524,811 B2	1/2020	Marchand et al.
9,005,172 B2	4/2015	Chung	10,531,883 B1	1/2020	Deville et al.
9,011,551 B2	4/2015	Oral et al.	10,588,655 B2	3/2020	Rosenbluth et al.
9,028,401 B1	5/2015	Bacich et al.	10,648,268 B2*	5/2020	Jaffrey et al. F16K 7/06
9,078,682 B2	7/2015	Lenker et al.	10,695,159 B2	6/2020	Hauser
9,101,382 B2	8/2015	Krolik et al.	10,709,471 B2	7/2020	Rosenbluth et al.
9,125,683 B2	9/2015	Farhangnia et al.	10,772,636 B2	9/2020	Kassab et al.
9,126,016 B2	9/2015	Fulton	10,799,331 B2	10/2020	Hauser
9,149,609 B2	10/2015	Ansel et al.	10,912,577 B2	2/2021	Marchand et al.
9,155,552 B2	10/2015	Ulm, III	10,926,060 B2	2/2021	Stern et al.
9,161,766 B2	10/2015	Slee et al.	10,953,195 B2	3/2021	Jalgaonkar et al.
9,168,043 B2	10/2015	van der Burg et al.	10,960,114 B2	3/2021	Goisis
9,173,668 B2	11/2015	Ulm, III	11,000,682 B2	5/2021	Merritt et al.
9,186,487 B2	11/2015	Dubrul et al.	11,013,523 B2	5/2021	Arad Hadar
9,204,887 B2	12/2015	Cully et al.	11,058,445 B2	7/2021	Cox et al.
9,216,277 B2	12/2015	Myers	11,058,451 B2	7/2021	Marchand et al.
9,241,669 B2	1/2016	Pugh et al.	11,065,019 B1	7/2021	Chou et al.
9,358,037 B2	1/2016	Farhangnia et al.	11,147,571 B2	10/2021	Cox et al.
9,259,237 B2	2/2016	Quick et al.	11,154,314 B2	10/2021	Quick
9,265,512 B2	2/2016	Carrison et al.	11,166,703 B2	11/2021	Kassab et al.
9,283,066 B2	3/2016	Hopkins et al.	11,185,664 B2	11/2021	Carrison et al.
9,301,769 B2	4/2016	Brady et al.	11,224,450 B2	1/2022	Chou et al.
9,351,747 B2	5/2016	Kugler et al.	11,224,721 B2	1/2022	Carrison et al.
9,439,664 B2	9/2016	Sos	11,259,821 B2	3/2022	Buck et al.
9,439,751 B2	9/2016	White et al.	11,305,094 B2	4/2022	Carrison et al.
9,456,834 B2	10/2016	Folk	11,383,064 B2	7/2022	Carrison et al.
9,463,035 B1	10/2016	Greenhalgh et al.	11,395,903 B2	7/2022	Carrison et al.
9,463,036 B2	10/2016	Brady et al.	11,406,801 B2	8/2022	Fotjik et al.
9,526,864 B2	12/2016	Quick	11,433,218 B2	9/2022	Quick et al.
9,526,865 B2	12/2016	Quick	11,439,799 B2	9/2022	Buck et al.
9,532,792 B2	1/2017	Galdonik et al.	11,457,936 B2	10/2022	Buck et al.
9,566,073 B2	2/2017	Kassab et al.	11,529,158 B2	12/2022	Hauser
9,566,424 B2	2/2017	Pessin	11,554,005 B2	1/2023	Merritt et al.
9,579,116 B1	2/2017	Nguyen et al.	11,559,382 B2	1/2023	Merritt et al.
9,581,942 B1	2/2017	Shippert	11,576,691 B2	2/2023	Chou et al.
9,616,213 B2	4/2017	Furnish et al.	11,596,768 B2	3/2023	Stern et al.
9,636,206 B2	5/2017	Nguyen et al.	11,642,209 B2	5/2023	Merritt et al.
9,643,035 B2	5/2017	Mastenbroek	11,648,028 B2	5/2023	Rosenbluth et al.
9,662,129 B2	5/2017	Galdonik et al.	11,697,011 B2	7/2023	Merritt et al.
9,700,332 B2	7/2017	Marchand et al.	11,697,012 B2	7/2023	Merritt et al.
9,717,488 B2	8/2017	Kassab et al.	11,744,691 B2	9/2023	Merritt et al.
9,717,514 B2	8/2017	Martin et al.	2001/0004699 A1	6/2001	Gittings et al.
9,717,519 B2	8/2017	Rosenbluth et al.	2001/0031981 A1	10/2001	Evans et al.
9,744,024 B2	8/2017	Nguyen et al.	2001/0041909 A1	11/2001	Tsugita et al.
9,757,137 B2	9/2017	Krolik et al.	2001/0049486 A1	12/2001	Evans et al.
9,827,084 B2	11/2017	Bonnette et al.	2001/0051810 A1	12/2001	Dubrul et al.
9,844,386 B2	12/2017	Nguyen et al.	2002/0022858 A1	2/2002	Demond et al.
9,844,387 B2	12/2017	Marchand et al.	2002/0022859 A1	2/2002	Hogendijk
9,848,975 B2	12/2017	Hauser	2002/0026211 A1	2/2002	Khosravi et al.
9,849,014 B2	12/2017	Kusleika	2002/0032455 A1	3/2002	Boock et al.
9,962,178 B2	5/2018	Greenhalgh et al.	2002/0049452 A1	4/2002	Kurz et al.
9,980,813 B2*	5/2018	Eller A61F 2/2469 623/1.24	2002/0095161 A1	7/2002	Dhindsa
9,999,493 B2	6/2018	Nguyen et al.	2002/0095171 A1	7/2002	Belef
10,004,531 B2	6/2018	Rosenbluth et al.	2002/0111648 A1	8/2002	Kusleika et al.
10,010,335 B2	7/2018	Greenhalgh et al.	2002/0120277 A1	8/2002	Hauschild et al.
10,016,266 B2	7/2018	Hauser	2002/0147458 A1	10/2002	Hiblar et al.
10,028,759 B2	7/2018	Wallace et al.	2002/0151918 A1	10/2002	Lafontaine et al.
10,045,790 B2	8/2018	Cox et al.	2002/0156457 A1	10/2002	Fisher
10,058,339 B2	8/2018	Galdonik et al.	2002/0161392 A1	10/2002	Dubrul
10,098,651 B2	10/2018	Marchand et al.	2002/0169474 A1	11/2002	Kusleika
10,130,385 B2	11/2018	Farhangnia et al.	2002/0173819 A1	11/2002	Leeflang et al.
10,183,159 B2*	1/2019	Nobles A61M 39/22	2002/0188276 A1	12/2002	Evans et al.
10,226,263 B2	3/2019	Look et al.	2003/0083693 A1	5/2003	Daniel et al.
10,238,406 B2	3/2019	Cox et al.	2003/0100919 A1	5/2003	Hopkins et al.
10,271,864 B2	4/2019	Greenhalgh et al.	2003/0114875 A1	6/2003	Sjostrom
10,327,883 B2	6/2019	Yachia	2003/0116731 A1*	6/2003	Hartley F16K 7/06 251/297
			2003/0125663 A1	7/2003	Coleman et al.
			2003/0135230 A1	7/2003	Massey et al.
			2003/0135258 A1	7/2003	Andreas et al.
			2003/0153873 A1	8/2003	Luther et al.

(56)	References Cited	2008/0087853 A1*	4/2008	Kees	F16K 7/065 251/5
	U.S. PATENT DOCUMENTS	2008/0088055 A1	4/2008	Ross	
		2008/0157017 A1	7/2008	Macatangay et al.	
		2008/0167678 A1	7/2008	Morsi	
		2008/0183136 A1	7/2008	Lenker et al.	
		2008/0228209 A1	9/2008	DeMello et al.	
		2008/0234715 A1	9/2008	Pesce et al.	
		2008/0234722 A1	9/2008	Bonnette et al.	
		2008/0262528 A1	10/2008	Martin	
		2008/0269798 A1	10/2008	Ramzipoor et al.	
		2008/0300466 A1	12/2008	Gresham	
		2008/0312681 A1	12/2008	Ansel et al.	
		2009/0018566 A1	1/2009	Escudero et al.	
		2009/0054918 A1	2/2009	Henson	
		2009/0062841 A1	3/2009	Amplatz et al.	
		2009/0069828 A1	3/2009	Martin et al.	
		2009/0076417 A1	3/2009	Jones	
		2009/0160112 A1	6/2009	Ostrovsky	
		2009/0163846 A1	6/2009	Aklog et al.	
		2009/0182362 A1	7/2009	Thompson et al.	
		2009/0192495 A1	7/2009	Ostrovsky et al.	
		2009/0281525 A1	11/2009	Harding et al.	
		2009/0292307 A1	11/2009	Razack	
		2009/0299393 A1	12/2009	Martin et al.	
		2010/0016837 A1	1/2010	Howat	
		2010/0030256 A1	2/2010	Dubrul et al.	
		2010/0042136 A1	2/2010	Berrada et al.	
		2010/0087844 A1	4/2010	Fischer, Jr.	
		2010/0087850 A1	4/2010	Razack	
		2010/0094201 A1	4/2010	Mallaby	
		2010/0106081 A1	4/2010	Brandeis	
		2010/0114113 A1	5/2010	Dubrul et al.	
		2010/0121312 A1	5/2010	Gielenz et al.	
		2010/0137846 A1	6/2010	Desai et al.	
		2010/0190156 A1	7/2010	Van Wordragen et al.	
		2010/0204712 A1	8/2010	Mallaby	
		2010/0217276 A1	8/2010	Garrison et al.	
		2010/0249815 A1	9/2010	Jantzen et al.	
		2010/0268264 A1	10/2010	Bonnette et al.	
		2010/0318178 A1	12/2010	Rapaport et al.	
		2011/0034986 A1	2/2011	Chou et al.	
		2011/0034987 A1	2/2011	Kennedy	
		2011/0054405 A1	3/2011	Whiting et al.	
		2011/0060212 A1	3/2011	Slee et al.	
		2011/0071503 A1	3/2011	Takagi et al.	
		2011/0118817 A1	5/2011	Gunderson et al.	
		2011/0125181 A1	5/2011	Brady et al.	
		2011/0144592 A1*	6/2011	Wong	A61M 39/0613 604/175
		2011/0152823 A1	6/2011	Mohiuddin et al.	
		2011/0152993 A1	6/2011	Marchand et al.	
		2011/0160742 A1	6/2011	Ferrera et al.	
		2011/0160763 A1	6/2011	Ferrera et al.	
		2011/0190806 A1	8/2011	Wittens	
		2011/0196309 A1	8/2011	Wells	
		2011/0196414 A1	8/2011	Porter et al.	
		2011/0213290 A1	9/2011	Chin et al.	
		2011/0213403 A1	9/2011	Aboytes	
		2011/0224707 A1	9/2011	Miloslavski et al.	
		2011/0245807 A1	10/2011	Sakata et al.	
		2011/0251629 A1	10/2011	Galdonik et al.	
		2011/0264133 A1	10/2011	Hanlon et al.	
		2011/0265681 A1	11/2011	Allen et al.	
		2011/0288529 A1	11/2011	Fulton	
		2011/0288572 A1	11/2011	Martin	
		2011/0319917 A1	12/2011	Ferrera et al.	
		2012/0059309 A1	3/2012	di Palma et al.	
		2012/0059356 A1	3/2012	di Palma et al.	
		2012/0083824 A1	4/2012	Berrada et al.	
		2012/0083868 A1	4/2012	Shrivastava	
		2012/0089216 A1	4/2012	Rapaport et al.	
		2012/0101480 A1	4/2012	Ingle et al.	
		2012/0101510 A1	4/2012	Lenker et al.	
		2012/0109109 A1	5/2012	Kajii	
		2012/0138832 A1	6/2012	Townsend	
		2012/0143239 A1	6/2012	Aklog et al.	
		2012/0165919 A1	6/2012	Cox et al.	
		2012/0172918 A1	7/2012	Fifer et al.	

(56)

References Cited

U.S. PATENT DOCUMENTS

2012/0179181	A1	7/2012	Straub et al.	2015/0173782	A1	6/2015	Garrison et al.
2012/0197277	A1	8/2012	Stinis	2015/0190155	A1	7/2015	Ulm, III
2012/0232655	A1	9/2012	Lorrison et al.	2015/0190156	A1	7/2015	Ulm, III
2012/0271105	A1	10/2012	Nakamura et al.	2015/0196380	A1	7/2015	Berrada et al.
2012/0271231	A1	10/2012	Agrawal	2015/0196744	A1	7/2015	Aboytes
2012/0277788	A1	11/2012	Cattaneo	2015/0209058	A1	7/2015	Ferrera et al.
2012/0310166	A1	12/2012	Huff	2015/0209165	A1	7/2015	Grandfield et al.
2013/0030460	A1	1/2013	Marks et al.	2015/0238207	A1	8/2015	Cox et al.
2013/0035628	A1	2/2013	Garrison et al.	2015/0250578	A1	9/2015	Cook et al.
2013/0046332	A1	2/2013	Jones et al.	2015/0265299	A1	9/2015	Cooper et al.
2013/0066348	A1	3/2013	Fiorella et al.	2015/0305756	A1	10/2015	Rosenbluth
2013/0092012	A1	4/2013	Marchand et al.	2015/0305859	A1*	10/2015	Eller A61F 2/2469 623/1.24
2013/0096571	A1	4/2013	Massicotte et al.	2015/0352325	A1	12/2015	Quick
2013/0102996	A1	4/2013	Strauss	2015/0360001	A1	12/2015	Quick
2013/0116708	A1	5/2013	Ziniti et al.	2015/0374391	A1	12/2015	Quick
2013/0116721	A1	5/2013	Takagi et al.	2016/0022293	A1	1/2016	Dubrul et al.
2013/0126559	A1	5/2013	Cowan et al.	2016/0030708	A1	2/2016	Casiello et al.
2013/0144326	A1	6/2013	Brady et al.	2016/0038267	A1	2/2016	Allen et al.
2013/0150793	A1	6/2013	Beissel et al.	2016/0058540	A1	3/2016	Don Michael
2013/0165871	A1	6/2013	Fiorella et al.	2016/0074627	A1	3/2016	Cottone
2013/0184703	A1	7/2013	Shireman et al.	2016/0106353	A1	4/2016	Schuetz et al.
2013/0197454	A1	8/2013	Shibata et al.	2016/0106448	A1	4/2016	Brady et al.
2013/0197567	A1	8/2013	Brady et al.	2016/0106449	A1	4/2016	Brady et al.
2013/0204297	A1	8/2013	Melsheimer et al.	2016/0113663	A1	4/2016	Brady et al.
2013/0226196	A1	8/2013	Smith	2016/0113664	A1	4/2016	Brady et al.
2013/0281788	A1	10/2013	Garrison	2016/0113665	A1	4/2016	Brady et al.
2013/0289608	A1	10/2013	Tanaka et al.	2016/0113666	A1	4/2016	Quick
2013/0317589	A1	11/2013	Martin et al.	2016/0135829	A1	5/2016	Holoehwost et al.
2013/0345739	A1	12/2013	Brady et al.	2016/0143721	A1	5/2016	Rosenbluth
2014/0005712	A1	1/2014	Martin	2016/0151605	A1	6/2016	Welch et al.
2014/0005713	A1	1/2014	Bowman	2016/0192912	A1	7/2016	Kassab et al.
2014/0005715	A1	1/2014	Castella et al.	2016/0206344	A1	7/2016	Bruzzi et al.
2014/0005717	A1	1/2014	Martin et al.	2016/0008014	A1	8/2016	Rosenbluth
2014/0025048	A1	1/2014	Ward	2016/0220741	A1	8/2016	Garrison et al.
2014/0031856	A1	1/2014	Martin	2016/0228134	A1	8/2016	Martin et al.
2014/0046133	A1	2/2014	Nakamura et al.	2016/0262774	A1	9/2016	Honda
2014/0046243	A1	2/2014	Ray et al.	2016/0262790	A1	9/2016	Rosenbluth et al.
2014/0052161	A1	2/2014	Cully et al.	2016/0287276	A1	10/2016	Cox et al.
2014/0074144	A1	3/2014	Shrivastava et al.	2016/0367285	A1	12/2016	Sos
2014/0121672	A1	5/2014	Folk	2017/0014560	A1	1/2017	Minskoff et al.
2014/0155830	A1	6/2014	Bonnette et al.	2017/0021130	A1	1/2017	Dye
2014/0155980	A1	6/2014	Turjman	2017/0037548	A1	2/2017	Lee
2014/0180397	A1	6/2014	Gerberding et al.	2017/0042571	A1	2/2017	Levi
2014/0155908	A1	7/2014	Rosenbluth et al.	2017/0049942	A1	2/2017	Conlan et al.
2014/0188127	A1	7/2014	Dubrul et al.	2017/0056032	A1	3/2017	Look et al.
2014/0188143	A1	7/2014	Martin et al.	2017/0058623	A1	3/2017	Jaffrey et al.
2014/0222070	A1	8/2014	Belson et al.	2017/0079672	A1	3/2017	Quick
2014/0236219	A1	8/2014	Dubrul et al.	2017/0086864	A1	3/2017	Greenhalgh et al.
2014/0243882	A1	8/2014	Ma	2017/0100142	A1	4/2017	Look et al.
2014/0257253	A1	9/2014	Jemison	2017/0105743	A1	4/2017	Vale et al.
2014/0257363	A1	9/2014	Lippert	2017/0105745	A1	4/2017	Rosenbluth et al.
2014/0276403	A1	9/2014	Follmer et al.	2017/0112514	A1	4/2017	Marchand et al.
2014/0296868	A1	10/2014	Garrison et al.	2017/0143359	A1	5/2017	Nguyen et al.
2014/0303658	A1	10/2014	Bonnette et al.	2017/0143938	A1	5/2017	Ogle et al.
2014/0318354	A1	10/2014	Thompson et al.	2017/0112513	A1	7/2017	Marchand et al.
2014/0324091	A1	10/2014	Rosenbluth	2017/0189041	A1	7/2017	Cox et al.
2014/0330286	A1	11/2014	Wallace et al.	2017/0196576	A1	7/2017	Long et al.
2014/0336691	A1	11/2014	Jones et al.	2017/0233908	A1	8/2017	Kroczyński et al.
2014/0343593	A1	11/2014	Chin et al.	2017/0252057	A1	9/2017	Bonnette et al.
2014/0364896	A1	12/2014	Consigny	2017/0265878	A1	9/2017	Marchand et al.
2014/0371779	A1	12/2014	Vale et al.	2017/0281204	A1	10/2017	Garrison et al.
2015/0005781	A1	1/2015	Lund-Clausen et al.	2017/0303939	A1	10/2017	Greenhalgh et al.
2015/0005792	A1	1/2015	Ahn	2017/0303942	A1	10/2017	Greenhalgh et al.
2015/0018859	A1	1/2015	Quick	2017/0303947	A1	10/2017	Greenhalgh et al.
2015/0018860	A1	1/2015	Quick	2017/0303948	A1	10/2017	Wallace et al.
2015/0018929	A1	1/2015	Martin et al.	2017/0319221	A1	11/2017	Chu
2015/0025555	A1	1/2015	Sos	2017/0325839	A1	11/2017	Rosenbluth et al.
2015/0032144	A1	1/2015	Holloway	2017/0340867	A1	11/2017	Accisano, II
2015/0059908	A1	3/2015	Mollen	2017/0348014	A1	12/2017	Wallace et al.
2015/0088190	A1	3/2015	Jensen	2018/0042623	A1	2/2018	Batiste
2015/0127035	A1	5/2015	Trapp et al.	2018/0042624	A1	2/2018	Greenhalgh et al.
2015/0133990	A1	5/2015	Davidson	2018/0042626	A1	2/2018	Greenhalgh et al.
2015/0150672	A1	6/2015	Ma	2018/0055999	A1	3/2018	Bare et al.
2015/0164523	A1	6/2015	Brady et al.	2018/0064453	A1	3/2018	Garrison et al.
2015/0164666	A1	6/2015	Johnson et al.	2018/0064454	A1	3/2018	Losordo et al.
				2018/0070968	A1	3/2018	Wallace et al.
				2018/0092652	A1	4/2018	Marchand et al.
				2018/0104404	A1	4/2018	Ngo-Chu

(56)

References Cited

U.S. PATENT DOCUMENTS

2018/0105963 A1 4/2018 Quick
 2018/0125512 A1 5/2018 Nguyen et al.
 2018/0184912 A1 7/2018 Al-Ali
 2018/0193043 A1 7/2018 Marchand et al.
 2018/0236205 A1 8/2018 Krautkremer et al.
 2018/0250498 A1 9/2018 Stern et al.
 2018/0256177 A1 9/2018 Cooper et al.
 2018/0256178 A1 9/2018 Cox et al.
 2018/0296240 A1 10/2018 Rosenbluth et al.
 2018/0344339 A1 12/2018 Cox et al.
 2018/0361116 A1 12/2018 Quick et al.
 2019/0000492 A1 1/2019 Casey et al.
 2019/0015298 A1 1/2019 Beatty et al.
 2019/0046219 A1 2/2019 Marchand et al.
 2019/0070401 A1 3/2019 Merritt et al.
 2019/0117244 A1 4/2019 Wallace et al.
 2019/0133622 A1 5/2019 Wallace et al.
 2019/0133623 A1 5/2019 Wallace et al.
 2019/0133624 A1 5/2019 Wallace et al.
 2019/0133625 A1 5/2019 Wallace et al.
 2019/0133626 A1 5/2019 Wallace et al.
 2019/0133627 A1 5/2019 Wallace et al.
 2019/0150959 A1 5/2019 Cox et al.
 2019/0231373 A1 8/2019 Quick
 2019/0239910 A1 8/2019 Brady et al.
 2019/0321071 A1 10/2019 Marchand et al.
 2019/0336142 A1 11/2019 Torrie et al.
 2019/0336148 A1 11/2019 Greenhalgh et al.
 2019/0365395 A1 12/2019 Tran et al.
 2019/0366036 A1 12/2019 Jalgaonkar et al.
 2020/0046368 A1 2/2020 Merritt et al.
 2020/0046940 A1 2/2020 Carrison et al.
 2020/0113412 A1 4/2020 Jensen
 2020/0121334 A1 4/2020 Galdonik et al.
 2021/0022843 A1 1/2021 Hauser
 2021/0038385 A1 2/2021 Popp et al.
 2021/0113224 A1 4/2021 Dinh
 2021/0137667 A1 5/2021 Sonnette et al.
 2021/0138194 A1 5/2021 Carrison et al.
 2021/0186541 A1 6/2021 Thress
 2021/0205577 A1 7/2021 Jalgaonkar et al.
 2021/0236148 A1 8/2021 Marchand et al.
 2021/0290925 A1 9/2021 Merritt et al.
 2021/0315598 A1 10/2021 Buck et al.
 2021/0330344 A1 10/2021 Rosenbluth et al.
 2021/0378694 A1 12/2021 Thress et al.
 2021/0393278 A1 12/2021 O'Malley et al.
 2021/0404464 A1 12/2021 Patoskie
 2022/0000505 A1 1/2022 Hauser
 2022/0000506 A1 1/2022 Hauser
 2022/0000507 A1 1/2022 Hauser
 2022/0015798 A1 1/2022 Marchand et al.
 2022/0022898 A1 1/2022 Cox et al.
 2022/0033888 A1 2/2022 Schnall-Levin et al.
 2022/0039815 A1 2/2022 Thress et al.
 2022/0125451 A1 4/2022 Hauser
 2022/0142638 A1 5/2022 Enright et al.
 2022/0151647 A1 5/2022 Dolendo et al.
 2022/0152355 A1 5/2022 Dolendo et al.
 2022/0160381 A1 5/2022 Hauser
 2022/0160382 A1 5/2022 Hauser
 2022/0160383 A1 5/2022 Hauser
 2022/0211400 A1 7/2022 Cox et al.
 2022/0211992 A1 7/2022 Merritt et al.
 2022/0240959 A1 8/2022 Quick
 2022/0346800 A1 11/2022 Merritt et al.
 2022/0346801 A1 11/2022 Merritt et al.
 2022/0346813 A1 11/2022 Quick
 2022/0346814 A1 11/2022 Quick
 2022/0347455 A1 11/2022 Merritt et al.
 2022/0362512 A1 11/2022 Quick et al.
 2022/0370761 A1 11/2022 Chou et al.
 2023/0046775 A1 2/2023 Quick
 2023/0059721 A1 2/2023 Chou et al.
 2023/0062809 A1 3/2023 Merritt et al.

2023/0070120 A1 3/2023 Cox et al.
 2023/0122587 A1 4/2023 Chou et al.
 2023/0200970 A1 6/2023 Merritt et al.
 2023/0218310 A1 7/2023 Scheinblum et al.
 2023/0218313 A1 7/2023 Rosenbluth et al.
 2023/0218383 A1 7/2023 Merritt et al.
 2023/0233311 A1 7/2023 Merritt et al.
 2023/0240705 A1 8/2023 Rosenbluth et al.
 2023/0240706 A1 8/2023 Rosenbluth et al.
 2023/0241302 A1 8/2023 Merritt et al.
 2023/0248380 A1 8/2023 Long et al.
 2023/0270991 A1 8/2023 Merritt et al.

FOREIGN PATENT DOCUMENTS

CN 103764049 4/2014
 CN 103932756 7/2014
 CN 104068910 10/2014
 CN 106178227 12/2016
 CN 108348319 7/2018
 CN 110652645 1/2020
 CN 111281482 6/2020
 DE 102017004383 7/2018
 EP 1254634 11/2002
 EP 1867290 2/2013
 EP 2942624 11/2015
 EP 3583972 12/2019
 EP 3589348 1/2020
 EP 3620204 3/2020
 EP 3013404 4/2020
 EP 4137070 2/2023
 GB 1588072 4/1981
 GB 2498349 7/2013
 JP H6190049 7/1994
 JP H07323090 A 12/1995
 JP 2001522631 5/1999
 JP 2004097807 4/2004
 JP 2005-095242 6/2005
 JP 2005230132 9/2005
 JP 2005323702 11/2005
 JP 2006094876 4/2006
 JP 2011526820 1/2010
 WO WO1997017889 5/1997
 WO WO9833443 8/1998
 WO WO98338920 9/1998
 WO WO98339053 9/1998
 WO WO9851237 11/1998
 WO WO1999044542 9/1999
 WO WO0032118 6/2000
 WO WO2000053120 9/2000
 WO WO0202162 1/2002
 WO WO03015840 2/2003
 WO WO2004018916 3/2004
 WO WO2004093696 11/2004
 WO WO2005046736 5/2005
 WO WO2006029270 3/2006
 WO WO2006110186 10/2006
 WO WO2006124307 11/2006
 WO WO2007092820 8/2007
 WO WO2009082513 7/2009
 WO WO2009086482 7/2009
 WO WO2009155571 12/2009
 WO WO2010002549 1/2010
 WO WO2010010545 1/2010
 WO WO2010023671 3/2010
 WO WO2010049121 5/2010
 WO WO2010102307 9/2010
 WO WO2011032712 3/2011
 WO WO2011054531 5/2011
 WO WO2011073176 6/2011
 WO WO2012009675 1/2012
 WO WO2012011097 1/2012
 WO WO2012049652 4/2012
 WO WO2012065748 5/2012
 WO WO2012120490 9/2012
 WO WO2012162437 11/2012
 WO WO2014047650 3/2014
 WO WO2014081892 5/2014
 WO WO2015006782 1/2015

(56)

References Cited

FOREIGN PATENT DOCUMENTS

WO	WO2015061365	4/2015
WO	WO2015121424	8/2015
WO	WO2015179329	11/2015
WO	WO2015189354	12/2015
WO	WO2015191646	12/2015
WO	WO2016014955	1/2016
WO	WO2017024258	2/2017
WO	WO2017058280	4/2017
WO	WO2017070702	4/2017
WO	WO2017106877	6/2017
WO	WO2017189535	11/2017
WO	WO2017189550	11/2017
WO	WO2017189591	11/2017
WO	WO2017189615	11/2017
WO	WO2017210487	12/2017
WO	WO2018049317	3/2018
WO	WO2018065092	4/2018
WO	WO2018080590	5/2018
WO	WO2018148174	8/2018
WO	WO2019010318	1/2019
WO	WO2019050765	3/2019
WO	WO2019075444	4/2019
WO	WO2019094456	5/2019
WO	WO2019222117	11/2019
WO	WO2019246240	12/2019
WO	WO2020036809	2/2020
WO	WO2021067134	4/2021
WO	WO2021076954	4/2021
WO	WO2021127202	6/2021
WO	WO2021248042	12/2021
WO	WO2022032173	2/2022
WO	WO2022103848	5/2022
WO	WO2022109021	5/2022
WO	WO2022109034	5/2022
WO	WO2023137341	7/2023
WO	WO2023147353	8/2023
WO	WO2023154612	8/2023

OTHER PUBLICATIONS

Gibbs, et al., "Temporary Stent as a bail-out device during percutaneous transluminal coronary angioplasty: preliminary clinical experience," *British Heart Journal*, 1994, 71:372-377, Oct. 12, 1993, 6 pgs.

Gupta, S. et al., "Acute Pulmonary Embolism Advances in Treatment", JAPI, Association of Physicians India, Mar. 2008, vol. 56, 185-191.

International Search Report and Written Opinion for International App. No. PCT/US13/61470, dated Jan. 17, 2014, 7 pages.

International Search Report and Written Opinion for International App. No. PCT/US2014/046567, dated Nov. 3, 2014, 13 pages.

International Search Report and Written Opinion for International App. No. PCT/US2014/061645, dated Jan. 23, 2015, 15 pages.

International Search Report for International App. No. PCT/US13/71101, dated Mar. 31, 2014, 4 pages.

Konstantinides, S. et al., "Pulmonary embolism hotline 2012—Recent and expected trials", *Thrombosis and Haemostasis*, Jan. 9, 2013:33; 43-50.

Konstantinides, S. et al., "Pulmonary embolism: risk assessment and management", *European Society of Cardiology; European Heart Journal*, Sep. 7, 2012:33, 3014-3022.

Kucher, N. et al., "Percutaneous Catheter Thrombectomy Device for Acute Pulmonary Embolism: In Vitro and in Vivo Testing", *Circulation*, Sep. 2005:112:e28-e32.

Kucher, N., "Catheter Interventions in Massive Pulmonary Embolism", *Cardiology Rounds*, Mar. 2006 vol. 10, Issue 3, 6 pages.

Kucher, N. et al., "Management of Massive Pulmonary Embolism", *Radiology*, Sep. 2005:236:3852-858.

Kucher, N. et al., "Randomized, Controlled Trial of Ultrasound-Assisted Catheter-Directed Thrombolysis for Acute Intermediate-Risk Pulmonary Embolism." *Circulation*, 2014, 129, pp. 9 pages.

Kuo, W. et al., "Catheter-directed Therapy for the Treatment of Massive Pulmonary Embolism: Systematic Review and Meta-analysis of Modern Techniques", *Journal of Vascular and Interventional Radiology*, Nov. 2009:20:1431-1440.

Kuo, W. et al., "Catheter-Directed Embolectomy, Fragmentation, and Thrombolysis for the Treatment of Massive Pulmonary Embolism After Failure of Systemic Thrombolysis", *American College of Chest Physicians* 2008: 134:250-254.

Kuo, W. MD, "Endovascular Therapy for Acute Pulmonary Embolism", *Continuing Medical Education Society of Interventional Radiology ("CME")*; *Journal of Vascular and Interventional Radiology*, Feb. 2012: 23:167-179.

Lee, L. et al., "Massive pulmonary embolism: review of management strategies with a focus on catheter-based techniques", *Expert Rev. Cardiovasc. Ther.* 8(6), 863-873 (2010).

Liu, S. et al., "Massive Pulmonary Embolism: Treatment with the Rotarex Thrombectomy System", *Cardiovascular Interventional Radiology*; 2011: 34:106-113.

Muller-Hulsbeck, S. et al. "Mechanical Thrombectomy of Major and Massive Pulmonary Embolism with Use of the Amplatz Thrombectomy Device", *Investigative Radiology*, Jun. 2001:36:6:317-322.

Reekers, J. et al., "Mechanical Thrombectomy for Early Treatment of Massive Pulmonary Embolism", *Cardiovascular and Interventional Radiology*, 2003: 26:246-250.

Schmitz-Rode et al., "New Mesh Basket for Percutaneous Removal of Wall-Adherent Thrombi in Dialysis Shunts," *Cardiovasc Intervent Radiol* 16:7-10 1993 4 pgs.

Schmitz-Rode et al., "Temporary Pulmonary Stent Placement as Emergency Treatment of Pulmonary Embolism," *Journal of the American College of Cardiology*, vol. 48, No. 4, 2006 (5 pgs.).

Schmitz-Rode, T. et al., "Massive Pulmonary Embolism: Percutaneous Emergency Treatment by Pigtail Rotation Catheter", *JACC Journal of the American College of Cardiology*, Aug. 2000:36:2:375-380.

Spiotta, A et al., "Evolution of thrombectomy approaches and devices for acute stroke: a technical review." *J NeuroIntervent Surg* 2015, 7, pp. 7 pages.

Svilaas, T. et al., "Thrombus Aspiration During Primary Percutaneous Coronary Intervention." *The New England Journal of Medicine*, 2008, vol. 358, No. 6, 11 pages.

Tapson, V., "Acute Pulmonary Embolism", *The New England Journal of Medicine*, Mar. 6, 2008:358:2037-52.

The Penumbra Pivotal Stroke Trial Investigators, "The Penumbra Pivotal Stroke Trial: Safety and Effectiveness of a New Generation of Mechanical Devices for Clot Removal in Intracranial Large Vessel Occlusive Disease." *Stroke*, 2009, 40: p. 9 pages.

Truong et al., "Mechanical Thrombectomy of Iliocaval Thrombosis Using a Protective Expandable Sheath," *Cardiovasc Intervent Radiol* 27:254-258, 2004, 5 pgs.

Turk et al., "Adapt Fast study: a direct aspiration first pass technique for acute stroke thrombectomy." *J NeuroIntervent Surg*, vol. 6, 2014, 6 pages.

Uflacker, R., "Interventional Therapy for Pulmonary Embolism", *Journal of Vascular and Interventional Radiology*, Feb. 2001: 12:147-164.

Verma, R., MD et al. "Evaluation of a Newly Developed Percutaneous Thrombectomy Basket Device in Sheep With Central Pulmonary Embolisms", *Investigative Radiology*, Oct. 2006, 41, 729-734.

International Search Report and Written Opinion for International App. No. PCT/US2015/034987 filed Jun. 9, 2015, Applicant: Inceptus Medical, LLC, dated Sep. 17, 2015, 12 pages.

English translation of Japanese Office Action received for JP Application No. 2016-564210, Applicant: Inceptus Medical, LLC, dated Sep. 4, 2017, 4 pages.

Australian Exam Report received for AU Application No. 2015274704, Applicant: Inceptus Medical, LLC, dated Sep. 7, 2017, 3 pages.

European Search Report received for EP Application No. 15805810.7, Applicant: Inceptus Medical, LLC, dated Sep. 4, 2017, 6 pages.

International Search Report and Written Opinion for International App. No. PCT/US2016/067628 filed Dec. 19, 2016, Applicant: Inari Medical, Inc., dated Apr. 10, 2017, 11 pages.

(56)

References Cited

OTHER PUBLICATIONS

Goldhaber, S. et al. "Percutaneous Mechanical Thrombectomy for Acute Pulmonary Embolism—A Double-Edged Sword," American College of Chest Physicians, Aug. 2007, 132:2, 363-372.

Goldhaber, S., "Advanced treatment strategies for acute pulmonary embolism, including thrombolysis and embolectomy," Journal of Thrombosis and Haemostasis, 2009: 7 (Suppl. 1): 322-327.

International Search Report and Written Opinion for International App. No. PCT/US2017/029696, Date of Filing: Apr. 26, 2017, Applicant: Inari Medical, Inc., dated Sep. 15, 2017, 19 pages.

International Search Report and Written Opinion for International App. No. PCT/US2016/058536, Date of Filing: Oct. 24, 2016, Applicant: Inari Medical, Inc., dated Mar. 13, 2017, 14 pages.

European First Office Action received for EP Application No. 13838945.7, Applicant: Inari Medical, Inc., dated Oct. 26, 2018, 7 pages.

International Search Report and Written Opinion for International App. No. PCT/US2018/048786, Date of Filing: Aug. 30, 2018, Applicant: Inari Medical, Inc., dated Dec. 13, 2018, 12 pages.

International Search Report and Written Opinion for International App. No. PCT/US2018/055780, Date of Filing: Oct. 13, 2018, Applicant: Inceptus Medical LLC., dated Jan. 22, 2019, 8 pages.

European Search Report for European Application No. 16876941.2, Date of Filing: Dec. 19, 2016, Applicant: Inari Medical, Inc., dated Jul. 18, 2019, 7 pages.

Extended European Search Report for European Application No. 16858462.1, Date of Filing: Oct. 24, 2016, Applicant: Inari Medical, Inc., dated Jun. 3, 2019, 10 pages.

International Search Report and Written Opinion for International App. No. PCT/US2019/045794, Date of Filing: Aug. 8, 2019, Applicant: Inari Medical, Inc., dated Nov. 1, 2019, 17 pages.

Partial Supplementary European Search Report for European Application No. 17864818.4, Date of Filing: May 21, 2019, Applicant: Inari Medical, Inc., dated Apr. 24, 2020, 11 pages.

International Search Report and Written Opinion for International App. No. PCT/US2020/056067, Date of Filing: Oct. 16, 2020, Applicant: Inari Medical, Inc., dated Jan. 22, 2021, 8 pages.

Extended European Search Report for European Application No. 20191581.6, Applicant: Inari Medical, Inc., dated Mar. 31, 2021, 11 pages.

International Search Report and Written Opinion for International App. No. PCT/US2020/055645, Date of Filing: Dec. 17, 2020; Applicant: Inari Medical, Inc., dated Apr. 14, 2021, 12 pages.

Extended European Search Report for European Application No. 18853465.5, Applicant: Inari Medical, Inc., dated May 7, 2021, 2021, 7 pages.

Vorwerk, D. MD, et al., "Use of a Temporary Caval Filter to Assist Percutaneous Iliocaval Thrombectomy: Experimental Results." SCVIR, 1995, 4 pages.

PCT International Search Report and Written Opinion for International Appln. No. PCT/US2020/014854, dated Oct. 5, 2020 (13 pages).

PCT International Search Report and Written Opinion for International Appln. No. PCT/US2020/018655, dated Dec. 16, 2020 (22 pages).

PCT International Search Report and Written Opinion for International Appln. No. PCT/US2020/017684, dated Nov. 30, 2020 (19 pages).

Extended European Search Report for EP Patent Appln. No. 20185092.2 dated Sep. 11, 2020, 6 pages.

EP Examination Report for EP Patent Appln. No. 18745794.0 dated Jul. 20, 2020, 4 pages.

Wikipedia; Embolectomy; retrieved from the Internet: <https://en.wikipedia.org/wiki/Embolectomy>; 4 pgs.; retrieved/printed: Mar. 24, 2016.

O'Sullivan; Thrombolysis versus thrombectomy in acute deep vein thrombosis; interventional Cardiology; 3(5); pp. 589-596; Oct. 2011.

Capture Vascular Systems; (company website); retrieved from the internet: <http://www.capturevascular.com>; 3 pgs.; retrieved/printed: Mar. 24, 2016.

Edwards Lifesciences; Fogarty® Occlusion Catheters (product brochure); retrieved from the internet: <http://web.archive.org/web/20150228193218/http://www.edwards.com/products/vascular/atraumaticocclusion/pages/occlusioncatheter.aspx>; © 2011; 2 pgs.; retrieved/printed: Mar. 24, 2011.

Boston Scientific; Fetch(TM) 2 Aspiration Catheter (product information); retrieved from the internet: <http://www.bostonscientific.com/en-US/products/thrombectomy-systems/fetch2-aspiration-catheter.html>; 2 pgs.; retrieved/printed: Mar. 24, 2016.

Penumbra, Inc.; Indigo® System (product information); retrieved from the internet: <http://www.penumbra.com/peripheralpercutaneous-thromboembolectomy/indigo-system>; 7 pgs.; retrieved/printed: Mar. 24, 2016.

Youtube; Merci Retrieval System X Series Animation; uploaded Mar. 16, 2009 (product information); posted on May 7, 2009 by SSMDePAUL, time 1:09, retrieved from the internet: <https://www.youtube.com/watch?v=MGX7deuFkhc>; 3 pgs.; retrieved/printed: Mar. 24, 2016.

Covidien; Solitaire(TM) AS Neurovascular Remodeling Device (product information); retrieved from the internet: <http://www.ev3.net/neuro/intl/remodeling-devices/solitaire-ab.htm>; © 2015; 2 pgs.; retrieved/printed: Mar. 24, 2016.

PCT International Search Report and Written Opinion for International Patent Appln. No. PCT/US2019/050467, Applicant Stryker Corporation, dated Dec. 18, 2019 (17 pages).

PCT International Search Report and Written Opinion for International Appln. No. PCT/US2017/029440, Applicant Stryker Corporation, dated Jul. 7, 2017.

PCT International Search Report and Written Opinion for International Appln. No. PCT/US2017/029472, Applicant Stryker Corporation, dated Jul. 7, 2017.

PCT International Search Report and Written Opinion for International Appln. No. PCT/US2017/035543, Applicant Stryker Corporation, dated Aug. 14, 2017.

PCT International Search Report and Written Opinion for International Appln. No. PCT/US2017/029366, Applicant Stryker Corporation, dated Aug. 29, 2017.

PCT International Search Report and Written Opinion for International Appln. No. PCT/US2017/050933, Applicant Stryker Corporation, forms PCT/ISA/210, 220, and 237, dated Nov. 10, 2017 (16 pages).

International search report and written opinion dated Feb. 28, 2018 for PCT/US2017/029345, Applicant Stryker Corporation 26 pages.

Extended European Search Report dated Aug. 22, 2018 for European patent appln No. 16852212.6, 6 pages.

Extended European Search Report dated Oct. 5, 2018 for European patent appln No. 18174891.4, 6 pages.

International search report and written opinion dated Nov. 14, 2018 for PCT/US2018/040937, Applicant Stryker Corporation 16 pages.

International Search Report and Written Opinion dated Mar. 28, 2019 for International Appln. No. PCT/US2018/059607.

International Search Report and Written Opinion dated May 6, 2016 for PCT/US2016/017982.

PCT International Search Report and Written Opinion for International Patent Appln. No. PCT/US2019/032601, Applicant Stryker Corporation, dated Jul. 23, 2019 (12 pages).

Extended European Search Report dated Oct. 8, 2019 for European Patent Application No. 19191925.7.

International Search Report and Written Opinion for International Patent Appln. No. PCT/US2019/050410 dated Oct. 25, 2019.

International Search Report and Written Opinion for International App. No. PCT/US21/35965, Date of Filing: Jun. 4, 2021, Applicant: Inari Medical, Inc., dated Sep. 28, 2021, 12 pages.

International Search Report and Written Opinion for International App. No. PCT/US21/45072 Date of Filing: Aug. 6, 2021, Applicant: Inari Medical, Inc., dated Jan. 20, 2022, 10 pages.

International Search Report and Written Opinion for International App. No. PCT/US21/58793; Date of Filing: Nov. 10, 2021, Applicant: Inari Medical, Inc., dated Mar. 16, 2022, 13 pages.

(56)

References Cited

OTHER PUBLICATIONS

International Search Report and Written Opinion for International App. No. PCT/US21/59718; Date of Filing: Nov. 17, 2021, Applicant: Inari Medical, Inc., dated Mar. 22, 2022, 13 pages.

International Search Report and Written Opinion for International App. No. PCT/US21/59735; Date of Filing: Nov. 17, 2021, Applicant: Inari Medical, Inc., dated Mar. 22, 2022, 11 pages.

International Search Report and Written Opinion for International App. No. PCT/US23/60502; Date of Filing: Jan. 11, 2023, Applicant: Inari Medical, Inc., dated May 25, 2023, 9 pages.

International Search Report and Written Opinion for International App. No. PCT/US23/61256; Date of Filing: Jan. 25, 2023, Applicant: Inari Medical, Inc., dated Jun. 7, 2023, 8 pages.

Gross et al., "Dump the pump: manual aspiration thrombectomy (MAT) with a syringe is technically effective, expeditious, and cost-efficient," J NeuroIntervent Surg, 2018, 4 pages.

International Search Report and Written Opinion for International App. No. PCT/US23/60927; Date of Filing: Jan. 19, 2023, Applicant: Inari Medical, Inc., dated Jul. 20, 2023, 12 pages.

* cited by examiner

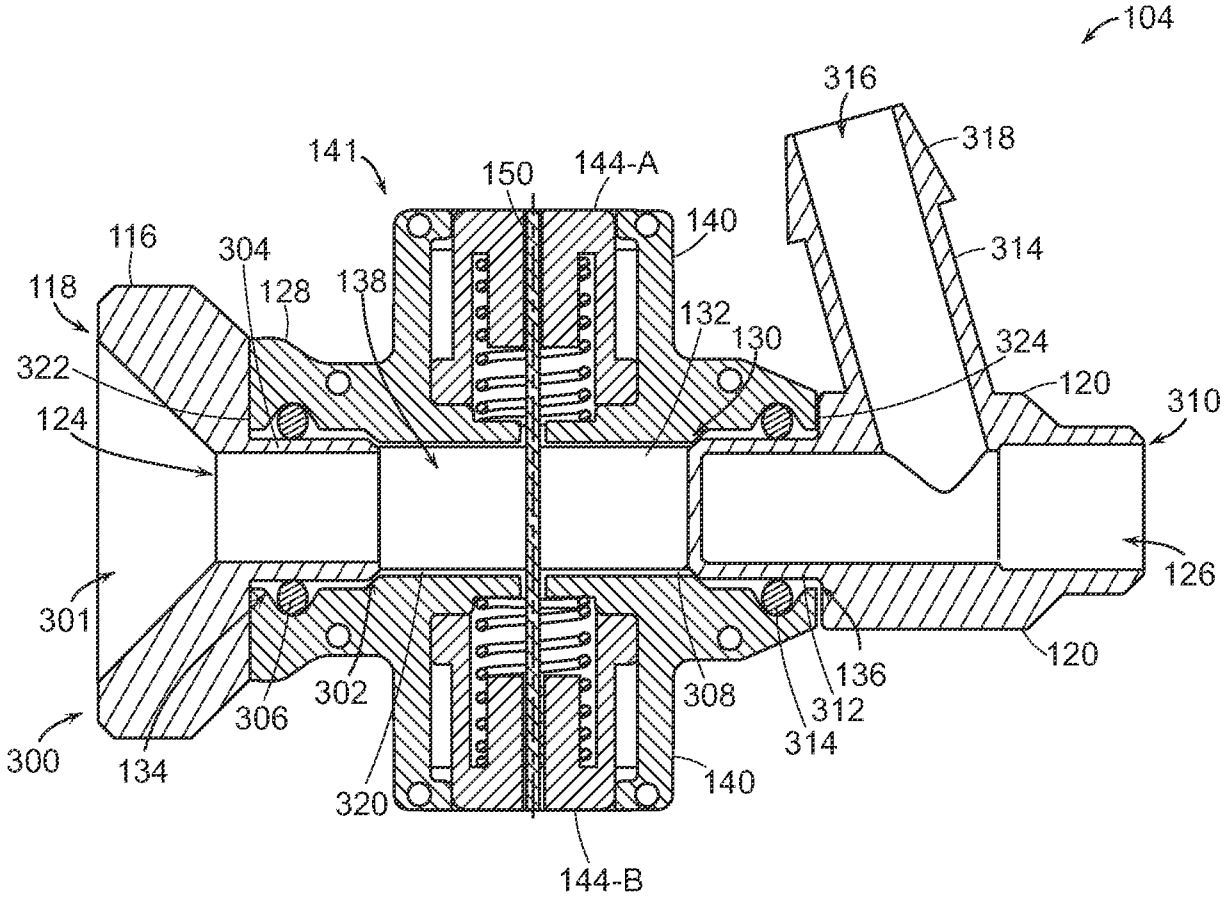

FIG. 3

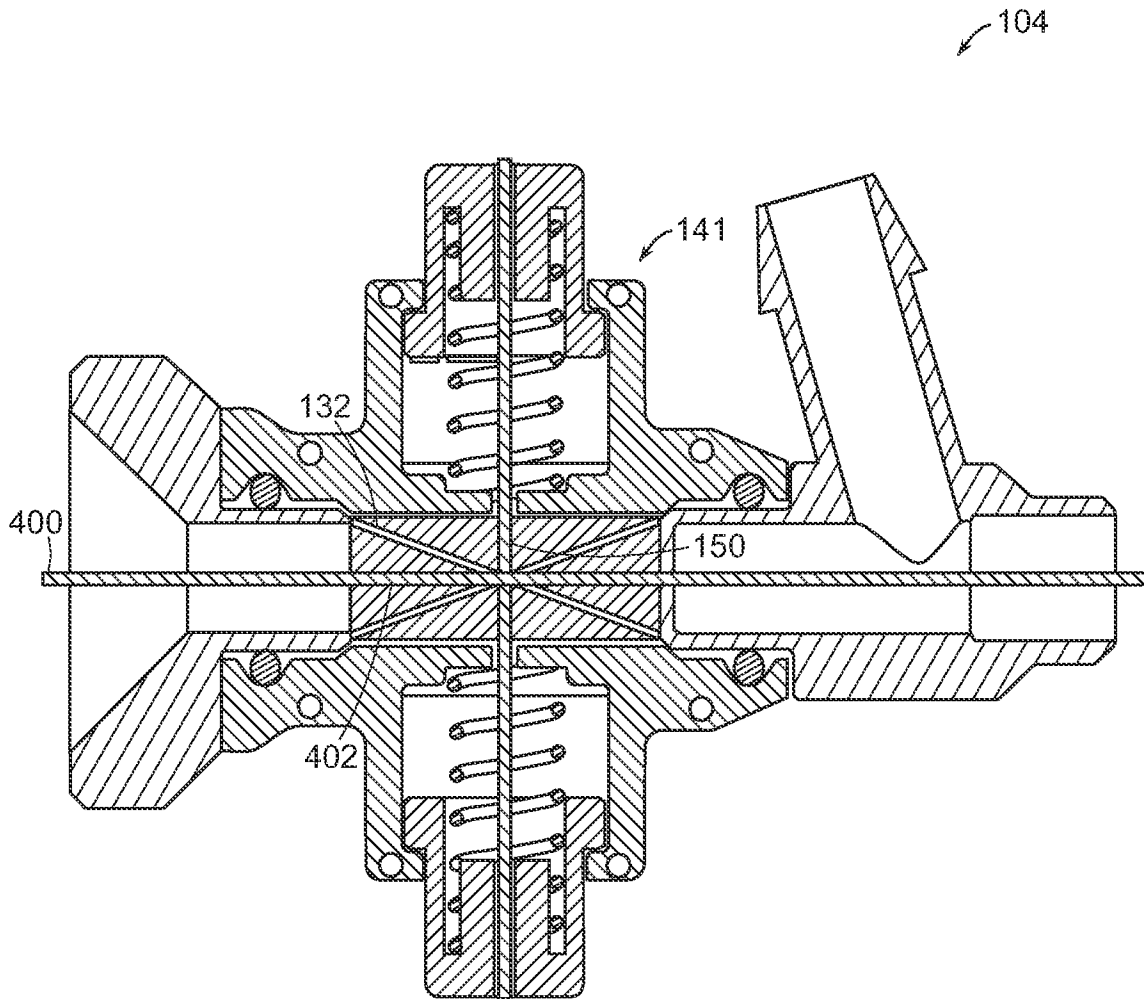

FIG. 4

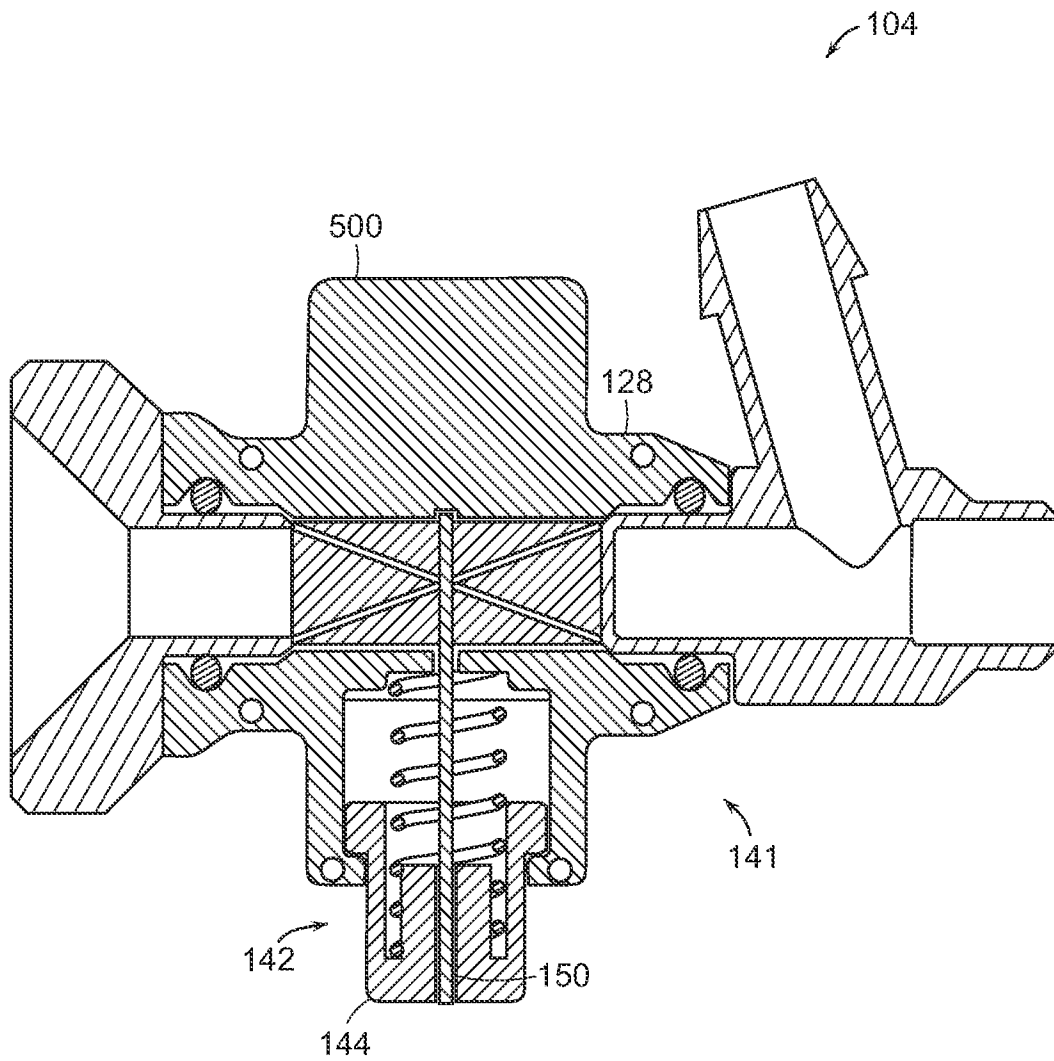

FIG. 5

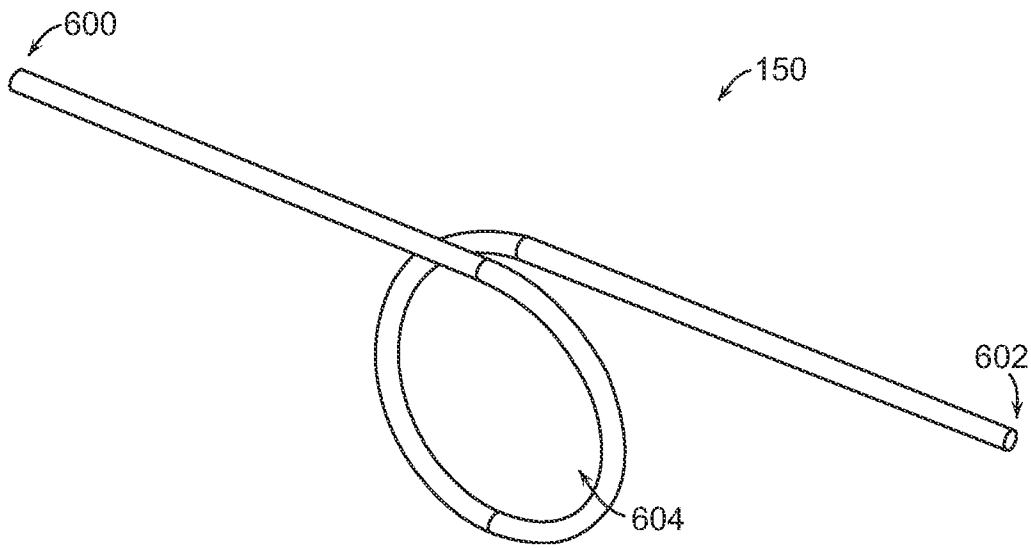

FIG. 6

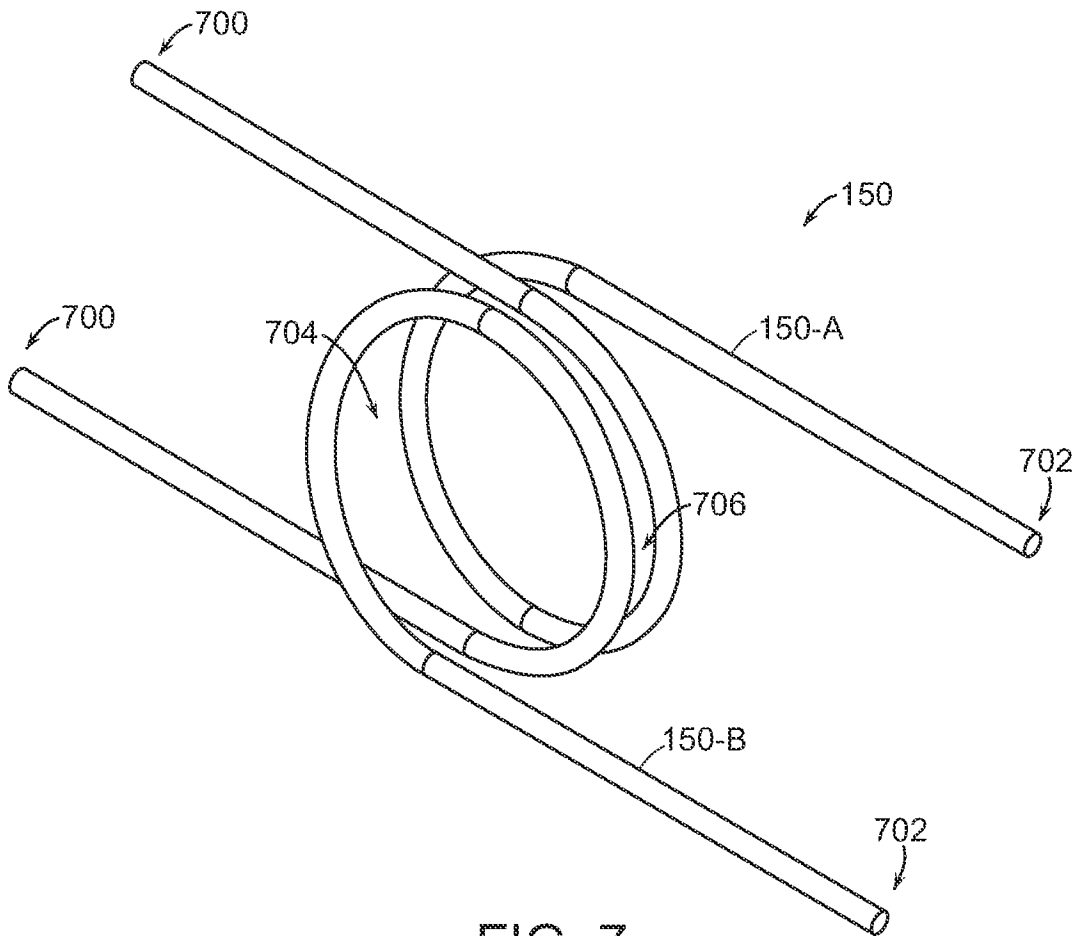

FIG. 7

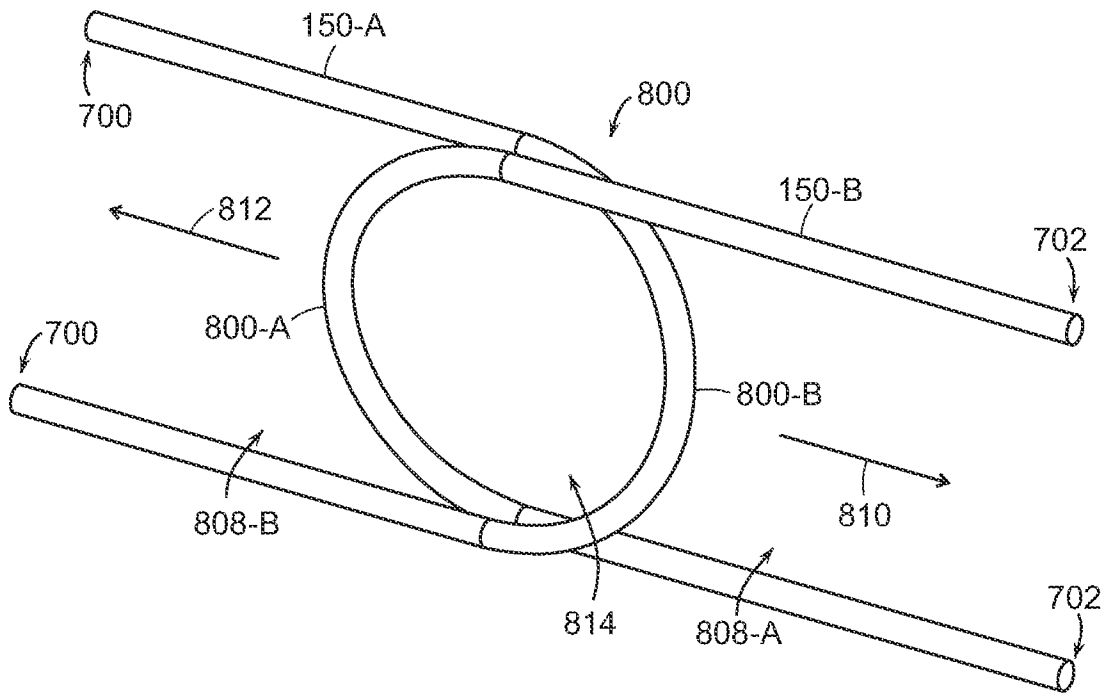

FIG. 8

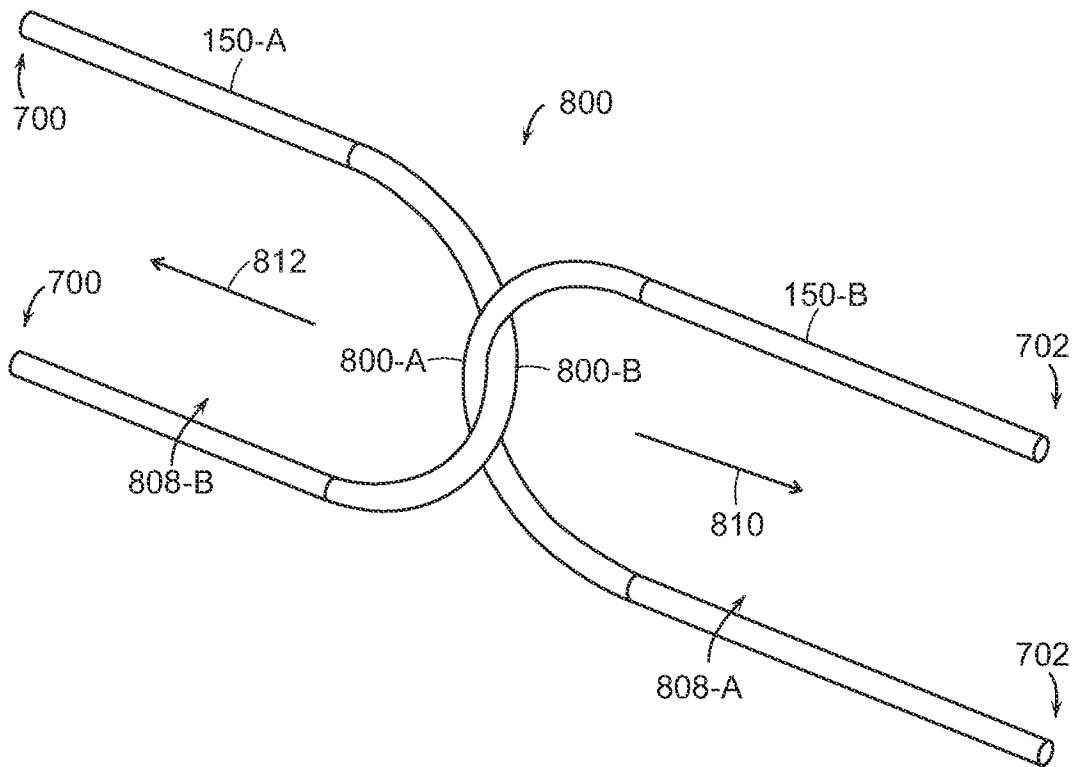

FIG. 9

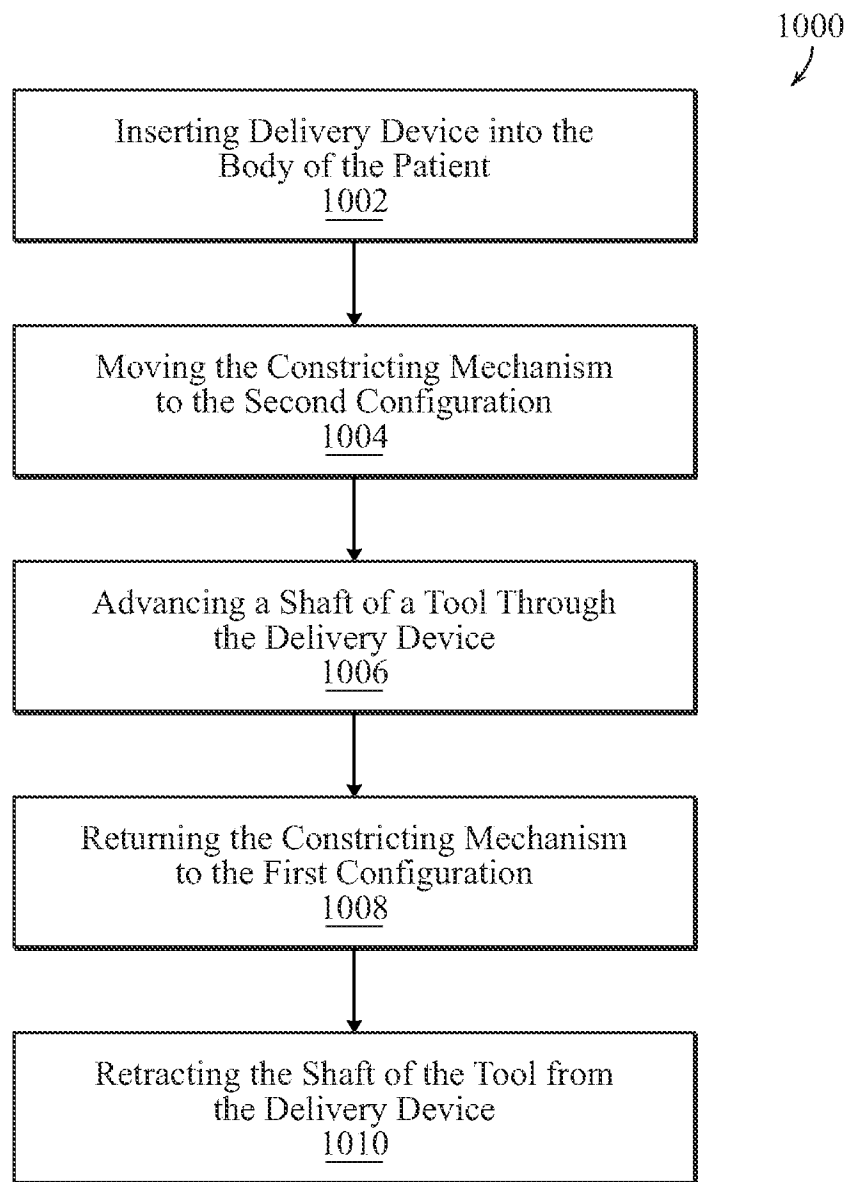

FIG. 10

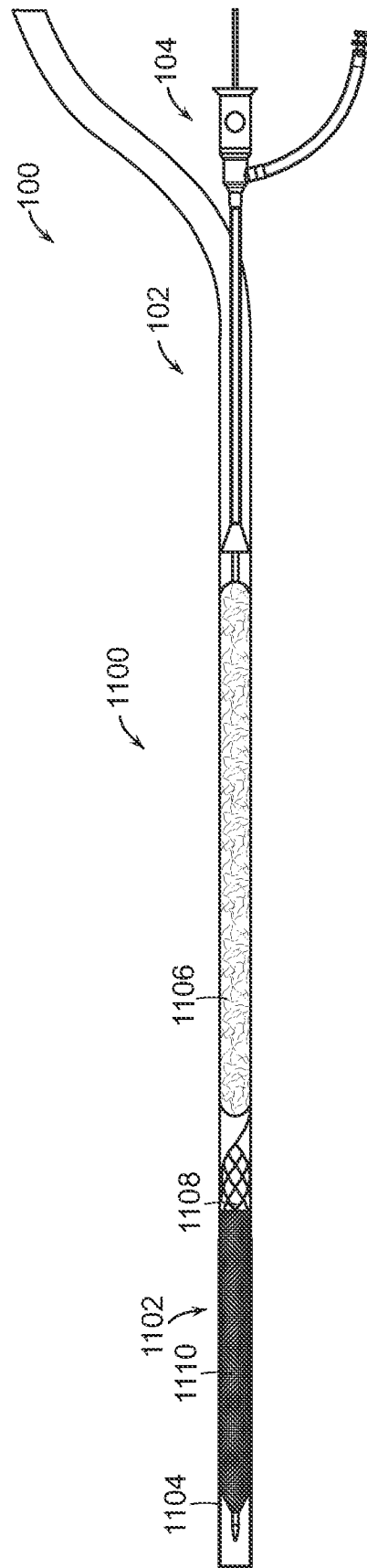

FIG. 11

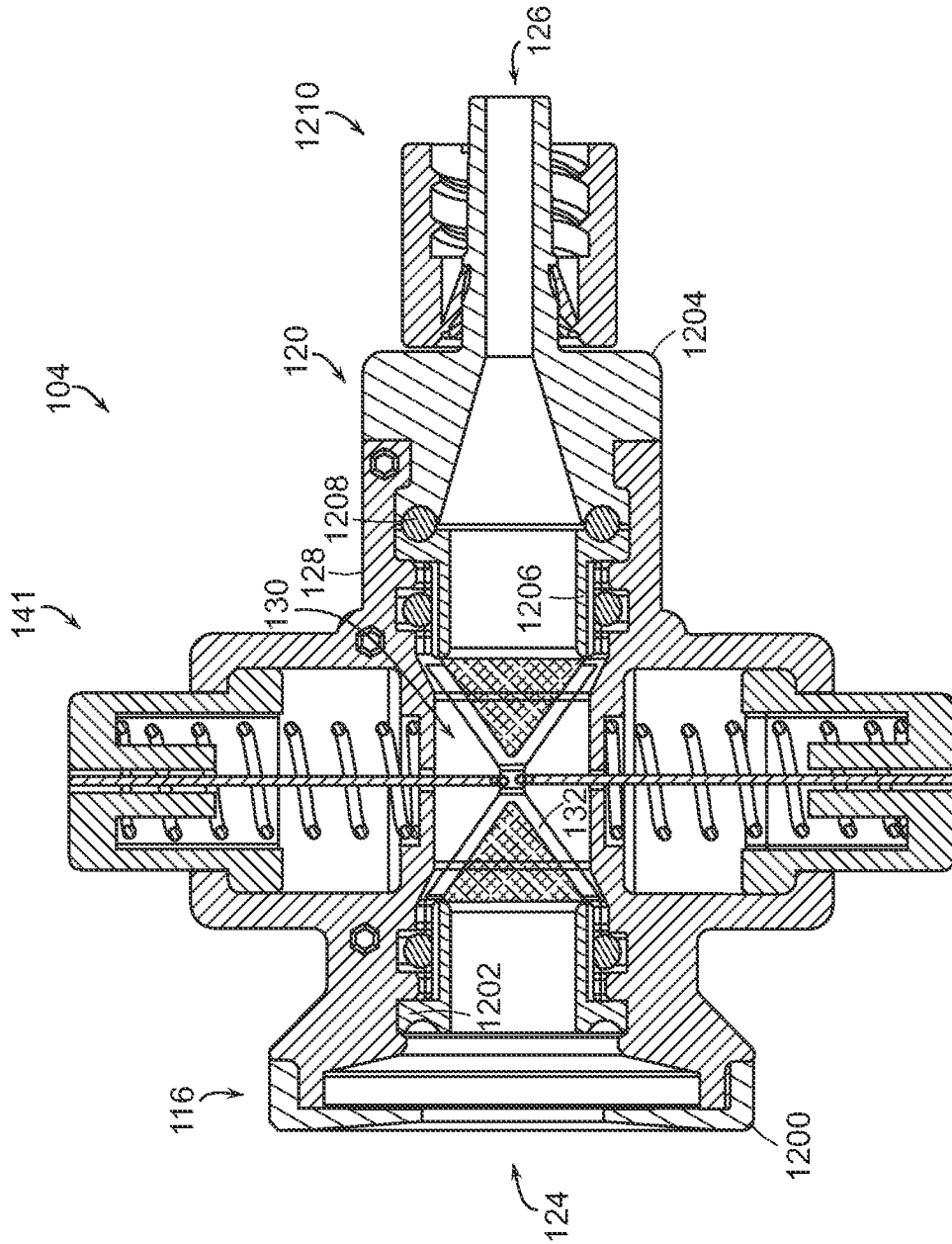

FIG. 12

1

HEMOSTASIS VALVES AND METHODS OF USE**CROSS-REFERENCE TO RELATED APPLICATIONS**

This application is a continuation of U.S. patent application Ser. No. 16/117,519, filed on Aug. 30, 2018, and titled "HEMOSTASIS VALVES AND METHODS OF USE," which claims the benefit of U.S. Provisional Patent Application No. 62/554,931, filed on Sep. 6, 2017, and titled "HEMOSTASIS VALVES AND METHODS OF USE," each of which is herein incorporated by reference in its entirety.

BACKGROUND

During a surgical procedure, a portion of a patient's body (e.g., vasculature) is accessed to allow for performance of a desired intervention or treatment. During such surgical procedures, it is desired to minimize patient blood loss, prevent delivery of air into the vasculature, and to maintain the sterility of the accessed portions or sites of the patient's body so as to prevent issues such as infection. Further, the desire for improved patient outcomes has led to the development of hemostasis valves that facilitate minimally invasive surgery.

In minimally invasive surgery, small incisions are created through a blood vessel which one or several catheters are inserted. Each of these one or several catheters can define a lumen extending longitudinally through that catheter. These catheters are moved to a position proximate to tissue, nerves, or other body structures targeted by the surgery, and then tools for performing the procedure are inserted through the lumens of some or all of these catheters.

To minimize blood loss, prevent delivery of air into the vasculature, and to facilitate maintenance of sterility within the patient's body (e.g., blood vessel), these catheters are equipped with hemostasis valves. These valves seal or selectively seal the lumens of the catheters. In many instances, these valves can seal the lumen of the catheter when a tool extends through the catheter, and specifically through the valve. Additionally the valves can seal the lumen when a tool is removed or does not extend through the catheter.

While such traditional hemostasis valves are greatly beneficial for intravascular access, they have some drawbacks. For example, some valves may not seal adequately for all interventional applications or tools, and/or the operation of some valves may be complicated for operator use. The drawbacks of such valve designs may in turn increase the complexity of any surgery performed therewith and/or reduce patient safety (e.g., bleeding, infection, and/or other detrimental complications). Accordingly, new and improved hemostasis valves and methods of use are desired.

SUMMARY

The following relates to valves, medical systems incorporating valves, and methods of using the same. The valve can include a tubular member that can be constricted, collapsed, and/or sealed by one or several tensioning mechanisms. The tensioning mechanism can include at least one filament that extends around at least a portion of the tubular member. The filament can interact with the tubular member to constrict, collapse, and/or seal the tubular member via manipulation of the tensioning mechanism(s). A tool can be inserted through the valve to gain access to a patient's body

2

and specifically to gain access to a blood vessel. Through the use of the tensioning mechanism and filament to constrict, collapse, and/or seal the tubular member, the valve can seal around a wide range of tool sizes and shapes, as well as multiple tools of differing sizes simultaneously. Additionally, such a valve creates a robust seal that maintains its seal when a vacuum is applied such as occurs during aspiration.

Aspects of the present disclosure relate to a hemostatic valve for sealing a medical device. The hemostatic valve includes an elongate member having a first end, a second end, and a central lumen extending therebetween. In some embodiments, the elongate member is pliable. The hemostatic valve can include a reinforcement structure extending along at least a portion of the elongate member, such that the reinforcement structure is coupled to the elongate member. The hemostatic valve includes an active tensioning mechanism coupled to the elongate member. In some embodiments, the tensioning mechanism is moveable between a first configuration in which the central lumen is constricted and sealed and a second configuration in which the central lumen is open. Optionally, the valve may be manually adjusted by the user to intermediate positions between fully open and fully closed. Additionally, an instrument (e.g. catheter) may provide an intermediate position where the valve creates hemostasis without user adjustment.

In some embodiments, the elongate member can be a compliant polymer tube. In some embodiments, the tensioning mechanism can include at least one filament extending at least partially around the elongate member. In some embodiments, the reinforcement structure is positioned between the at least one filament and the elongate member. In some embodiments, the reinforcement structure can be a braided mesh. In some embodiments, the reinforcement structure is coupled to the elongate member at a position proximate to the first end of the elongate member and at a position proximate to the second end of the elongate member. In some embodiments, the reinforcement structure is not coupled to the elongate member at a position between the first end of the elongate member and the second end of the elongate member. In some embodiments, the central portion of the compliant polymer tube that is constrained or collapsed by the tensioning mechanism, and at least one filament, is not coupled to the reinforcement structure.

In some embodiments, the tensioning mechanism can include an actuator coupled to the at least one filament. In some embodiments there are two tensioning mechanisms coupled to the at least one filament that operate in opposite directions. In some embodiments the two tensioning mechanisms are attached to the same filament. In some embodiments the two tensioning mechanisms are attached to opposing filaments. In some embodiments, the actuator can be moveable to control movement of the at least one filament from a first position in which the central lumen is constricted and sealed to a second position in which the central lumen is open. In some embodiments, the at least one filament is in the first position when the tensioning mechanism is in the first configuration. In some embodiments, the actuator is biased towards the first position. In some embodiments, the actuator is biased toward the second position. In some embodiments, the actuator can be a manual actuator.

In some embodiments, the at least one filament forms a loop around the elongate member. In some embodiments, the at least one filament forms a bight around a portion of the elongate member. In some embodiments, the at least one filament can include a first filament and a second filament. In some embodiments, each of the first filament and the second filament are coupled to the same actuator. In some

3

embodiments, each of the first filament and the second filament are coupled to different actuators. In some embodiments, the first filament and the second filament are moveable from the first position to the second position. In some embodiments, each of the first filament and the second filament form a loop around the elongate member. In some 5
embodiments, the first filament forms a first bight around a first portion of the elongate member, and the second filament forms a second bight around a second portion of the elongate member. In some embodiments, the first bight extends through the second bight.

In some embodiments, the hemostatic valve can include a shell defining a first aperture and a second aperture. In some embodiments, the elongate member extends from the first aperture to the second aperture and fluidly couples the first 15
aperture and the second aperture. In some embodiments, the tensioning mechanism is self-adjustable to seal around tools of different sizes extending through the hemostatic valve. In some embodiments, the central lumen can comprise a single lumen, and in some embodiments, the central lumen can comprise a plurality of lumens.

One aspect of the present disclosure relates to a delivery system for intravascular access of a blood vessel within a patient's body. The delivery system includes a catheter having a first end, a second end, and a catheter lumen 25
extending therebetween and a hemostatic valve coupled to the first end of the catheter. The hemostatic valve includes a tubular member having a first end, a second end, and a central lumen extending therebetween. In some embodiments, the central lumen of the tubular member is fluidly coupled with the catheter lumen. The hemostatic valve includes an active tensioning mechanism coupled to the tubular member, the tensioning mechanism can be moveable between a first configuration in which the tensioning mechanism constricts on the central lumen and the central lumen 30
is sealed and a second configuration in which the central lumen is open.

In some embodiments, the hemostatic valve further includes a reinforcement structure extending along at least a portion of the tubular member. In some embodiments, the 40
reinforcement structure is located between the tensioning mechanism and the tubular member. In some embodiments, the reinforcement structure can be a braided mesh. In some embodiments, the reinforcement structure is coupled to the tubular member at a position proximate to the first end of the tubular member and at a position proximate to the second end of the tubular member. In some embodiments, the reinforcement structure is adhered to the tubular member at the first end of the tubular member and at the second end of the tubular member. In some embodiments, the reinforcement 50
structure is uncoupled to the tubular member between the first end of the tubular member and the second end of the tubular member.

In some embodiments, the tensioning mechanism can include at least one filament extending at least partially 55
around the tubular member. In some embodiments, the tensioning mechanism can include an actuator coupled to the at least one filament. In some embodiments, moving the tensioning mechanism from the first configuration to the second configuration can include moving the actuator and the thereto coupled at least one filament from a first position to a second position. In some embodiments, the filament constricts and seals the central lumen of the tubular member when the filament is in the first position.

In some embodiments, the actuator can be a manual 65
actuator. In some embodiments, the actuator can include a pair of opposing and depressable buttons, which buttons can

4

be biased towards an undepressed position. In some embodiments, the central lumen is sealed when the buttons are in the undepressed position. In some embodiments, the filament can be a monofilament. In some embodiments, the filament can be at least one of: a polymer filament; or a metallic filament. In some embodiments, the catheter can include a thrombus extraction device.

One aspect of the present disclosure relates to a method of sealing a delivery device accessing a blood vessel of a patient. The method includes inserting the delivery device including a catheter and a hemostatic valve into the blood vessel of the patient. In some embodiments, the catheter can have a first end, a second end, and a catheter lumen extending therethrough. In some embodiments, the hemostatic valve can be coupled to the first end and can have a tubular member defining a central lumen fluidly coupled with the catheter lumen and a tensioning mechanism coupled with the tubular member. In some embodiments, the tensioning mechanism collapses and seals the central lumen in a first configuration and thereby seals access to the blood vessel. The method can include moving the tensioning mechanism of the hemostatic valve to a second configuration. In some embodiments, the central lumen is open and access to the blood vessel is unsealed when the tensioning mechanism is in the second configuration. The method can include advancing a shaft of a tool through the delivery device until a first end of the tool reaches a desired position within the blood vessel of the patient and a portion of the shaft is positioned within the central lumen of the tubular member. The method can include returning the tensioning mechanism of the hemostatic valve to the first configuration such that the tubular member collapses on the shaft of the tool and seals around the shaft of the tool.

In some embodiments, the method includes retracting the shaft of the tool from the delivery device. In some embodiments, the tensioning mechanism is maintained in the first configuration during and after the retracting of the shaft of the tool from the delivery device. In some embodiments, the tensioning mechanism is moved to the second configuration during the retracting of the shaft of the tool from the delivery device, and the tensioning mechanism is returned to the first configuration after the shaft of the tool is retracted from the delivery device.

In some embodiments, the tensioning mechanism can include at least one filament extending at least partially around the tubular member. In some embodiments, the at least one filament collapses the tubular member when the tensioning mechanism is in the first configuration. In some 50
embodiments, the at least one filament circumferentially constricts the tubular member to collapse the tubular member when the tensioning mechanism is in the first configuration. In some embodiments, the hemostatic valve can include a reinforcement structure located between the at least one filament and the tubular member.

In some embodiments, the at least one filament forms a loop around the elongate member, and moving the tensioning mechanism from the second configuration to the first configuration reduces a size of the loop to thereby constrict the tubular member within the loop. In some embodiments, the filament forms at least one bight around a portion of the elongate member. In some embodiments, the filament can include a first filament and a second filament. In some 60
embodiments, the at least one bight can include a first bight oriented in a first direction and formed by the first filament and a second bight oriented in a second direction and formed by the second filament. In some embodiments, the first and

5

second bights overlap to encircle a portion of the tubular member within a constricting area.

In some embodiments, moving the tensioning mechanism from the second configuration to the first configuration can include moving the first bight in the first direction and the second bight in the direction to reduce the size of the constricting area and collapse and seal the central lumen of the tubular member. In some embodiments, the tensioning mechanism can include an actuator. In some embodiments, moving the tensioning mechanism to the second configuration can include manipulating the actuator. In some embodiments, the method includes applying a vacuum to the delivery device and/or delivery system to aspirate material through the catheter. In some embodiments, the central lumen remains sealed during the aspiration. In some embodiments, the tool can include a thrombus extraction device.

BRIEF DESCRIPTION OF THE DRAWINGS

FIG. 1 is a perspective view of one embodiment of a delivery device.

FIG. 2 is a side-section view of one embodiment of a hemostasis valve in a first configuration.

FIG. 3 is a side-section view of one embodiment of the valve in a second configuration.

FIG. 4 is a side-section view of one embodiment of the valve in the first configuration and with a tool extending through the valve.

FIG. 5 is a side-section view of one embodiment of a single-button hemostasis valve in a first configuration.

FIG. 6 is a perspective view of a filament of a valve forming a loop.

FIG. 7 is a perspective view of two filaments of a valve, each of the filaments forming a loop.

FIG. 8 is a perspective view of two overlapping and interlocked bights in an open configuration.

FIG. 9 is a perspective view of two overlapping and interlocked bights in a closed configuration.

FIG. 10 is a flowchart illustrating one embodiment of a method for sealing a valve and/or catheter.

FIG. 11 is a side view of one embodiment of a thrombectomy system including the delivery device.

FIG. 12 is a side-section view of another embodiment of a hemostasis valve having two-piece caps.

DETAILED DESCRIPTION

The present disclosure relates to a valve that can be used as a hemostasis valve. This valve, also referred to herein as a garrote valve can seal with or without a tool extending through the valve. The garrote valve provides convenient, single-handed operation for a wide range of medical devices including catheters, wires, embolectomy systems, or the like. This single-handed operation of the garrote valve allows the user to easily and quickly swap different tools being used through the valve without compromising hemostasis and therefore simplifying the procedure. Combined with single-handed operation, the garrote valve provides robust sealing either with or without a tool extending through the valve. This robust sealing minimizes leakage in applications with a pressure differential on different sides of the valve. This pressure differential can arise, for example, during the application of vacuum aspiration in a procedure. Even under such conditions, as well as under other conditions, the garrote valve maintains seal integrity and prevents leakage in one or both directions.

6

The garrote valve includes a tubular member. The tubular member is a flexible member that defines a central lumen, which can, in some embodiments, define a single lumen, and in some embodiments, defines a plurality of lumens. In some embodiments, each of the plurality of lumens can comprise the same size and shape, and in some embodiments, some or all of the plurality of lumens can comprise different sizes and shapes. In some embodiments, for example, the plurality of lumens can comprise a lumen sized and/or shaped to receive a guide wire and a lumen sized and/or shaped to receive a tool. The tubular member extends at least partially through a constricting mechanism. The constricting mechanism can be moved from a first configuration to a second configuration, and the constricting mechanism can collapse and/or seal the central lumen of the tubular member when the constricting mechanism is in the first configuration. The constricting mechanism creates the above-discussed robust seal of the tubular member and thus of the valve.

With reference now to FIG. 1, a perspective view of one embodiment of a delivery system 100, also referred to herein as a delivery device 100, is shown. The delivery system 100 can include a catheter 102 and a garrote valve 104, also referred to herein as valve 104. The catheter 102 can comprise a shaft 106, also referred to herein as an elongate sheath 106, having a proximal end 108, also referred to herein as a first end 108, that can connect to the valve 104 and a distal end 110, also referred to herein as a second end 110. The shaft 106 can define a catheter lumen 112 extending from the proximal end 108 of the shaft 106 to the distal end 110 of the shaft 106. The catheter 102 and specifically the shaft 106 can comprise a variety of shapes and sizes and can be made from a variety of materials. In some embodiments, the catheter 102 can be flexible and/or can be made from a biocompatible material. The elongate sheath 106 can have an outer diameter of at least 4 French, at least 6 French, at least 8 French, at least 10 French, at least 12 French, at least 14 French, at least 18 French, at least 20 French, at least 22 French, between 4 French and 30 French, between 8 French and 24 French, between 12 French and 20 French, and/or any other or intermediate size.

The valve 104 can include an outer shell 114. The outer shell 114 can comprise a variety of shapes and sizes and can be made from a variety of materials. In some embodiments, the outer shell 114 can be made from one or several polymers or composites. The outer shell 114 can include features that allow interaction with and/or control of the valve 104 to move the valve 104 between the first configuration and the second configuration.

The outer shell 114 can include a proximal cap 116 located at a proximal end 118 of the outer shell 114 and a distal cap 120 located at a distal end 122 of the shell 114. The proximal cap 116 can include and/or house a proximal aperture 124, also referred to herein as a proximal channel 124, a first channel 124, or a first aperture 124, that extends through the proximal cap 116, and the distal cap 120 can include and/or house a distal aperture 126, also referred to herein as a distal channel 126, a second channel 126, or second aperture 126, that extends through the distal cap 120. As seen in FIG. 1, the distal cap 120 connects to the shaft 106 of the catheter 102 at the distal end 122 of the valve 104.

The proximal cap 116 and the distal cap 120 are connected via a housing 128. The housing 128 can be a one-piece housing 128 or a multi-piece housing 128. In the embodiment depicted in FIG. 1, the housing comprises a two-piece housing 128. The housing 128 can be configured to receive and couple with each of the proximal cap 116 and the distal cap 120, and as seen in FIG. 1, the housing 128 is coupled

with each of the proximal cap **116** and the distal cap **120** to secure the relative position of the proximal cap **116** and the distal cap **120** with respect to each other.

The housing **128** can define an interior channel **130** through which an elongate member **132**, also referred to herein as a tubular member **132**, a septum **132**, or a tubular septum **132**, can extend and connect the proximal cap **116** and the distal cap **120**. The elongate member **132** can comprise a variety of shapes and sizes and can be made from a variety of materials. In some embodiments, the elongate member **132** can comprise a compliant tubular structure that can be, for example, a thin-walled compliant tubular structure. The thin-walled structure of the elongate member **132** can facilitate the collapse, and specifically the uniform collapse of the elongate member **132** and the sealing of the elongate member **132**. In some embodiments, the elongate member **132** is an elastic, resilient material that may comprise a polymer including either a natural or synthetic polymer. In some embodiments, the elongate member can comprise an elastic, resilient material that may comprise silicone, urethane, ethylene-vinyl acetate, natural or synthetic rubber or other elastomers known in the art. In some embodiments, the elongate member **132** can comprise a silicone tube.

The elongate member **132** can comprise a proximal end **134**, also referred to herein as a first end **134**, that can couple to the proximal cap **116**, and a distal end **136**, also referred to herein as a second end **136**, that can couple to the distal cap **120**. The elongate member **132** can define a central lumen **138** that can extend from the first end **134** to the second end **136** of the elongate member **132**. The elongate member **132** can be coupled to the proximal cap **116** such that the central lumen **138** is fluidly coupled with the proximal aperture **124** of the proximal cap **116**, and the elongate member **132** can be coupled to the distal cap **120** such that the central lumen **138**, as seen in FIG. 2 and in FIG. 3, is fluidly coupled with the distal aperture **126** of the distal cap **120**.

The central lumen **138** of the elongate member **132** can be defined by a wall of the elongate member **132** that can have a thickness that is uniform along the length of the elongate member **132** between the first end **134** and the second end **136**, or that is non-uniform along the length of the elongate member **132** between the first end **134** and the second end **136**. In some embodiments, the wall can have a thickness that is approximately between 0.005 inches and 0.05 inches, and/or approximately between 0.010 inches and 0.030 inches. As used anywhere herein, "approximately" refers to a range of +/-10% of the value and/or range of values for which "approximately" is used.

In some embodiments, the elongate member **132** can be cylindrically shaped, and specifically can be circular-cylindrically shaped. In some embodiments, the elongate member **132** can be dog-bone shaped to facilitate, for example, connection to each of the proximal cap **116** and the distal cap **120**. In some embodiments, the elongate member **132** can include one or several outward-extending protuberances that engage with all or portions of a constricting mechanism **141**, also referred to herein as a tensioning mechanism **141**, of the valve **104** to secure a position of all or portions of the constricting mechanism **141** with respect to the elongate member **132**. In some embodiments, the constricting mechanism **141** can be self-adjusting to seal around tools of different sizes extending through the valve **104**.

The constricting mechanism **141** can, in some embodiments, collapse and seal the elongate member **132** via compression and/or constriction, and specifically via con-

striction with at least one filament **150**. The constricting mechanism **141** can comprise: an actuator **142** which can be a manual actuator such as one or several buttons **144**; and the at least one filament **150** that can extend at least partially around the elongate member **132**. In some embodiments, the use of the constricting mechanism **141** can facilitate sealing of the valve around tools or instruments of a wide range of sizes and/or diameters, and particularly around tools or instruments that fit through the elongate member **132**.

The housing **128** can further include one or several retention features **140**. The one or several retention features **140** of the housing can engage with and retain all or portions of the constricting mechanism **141** of the valve **104**. In some embodiments, the one or several retention features **140** of the housing **128** can retain the actuator **142** and/or can couple the actuator **142** to the housing **128**. The actuator **142** can comprise any desired type of actuator including, for example, a manual actuator and/or an automated actuator such as, for example, an electromechanical actuator including a solenoid-based actuator. In some embodiments, the actuator can comprise one or several buttons **144**, and specifically, as depicted in FIG. 1, the actuator **142** can comprise a first button **144-A** and a second button **144-B**. Alternatively, and as depicted in FIG. 5, the actuator **142** can comprise a single button **144**. In such an embodiment, the filament **150** can be coupled to the single button **144** and to a portion of the housing **128** such as, for example, to grip portion **500** of the housing **128** such that the movement of the single button **144** causes the sealing and/or opening of the elongate member **132** and of the valve **104**.

The actuator **142** can be biased towards a configuration such as, for example, biased towards the first configuration or biased towards the second configuration. As depicted in FIG. 2, which shows the constricting mechanism **141** in the first configuration, the actuator **142** can be biased towards the first configuration wherein the elongate member **132** is collapsed and/or sealed by a bias feature **146**. In this first configuration, the buttons **144** can be in a first position, also referred to herein as an undepressed position. This bias feature **146** can, as shown in FIG. 2, include a first spring **148-A** configured to bias the first button **144-A** towards the first position corresponding to the first configuration of the constricting mechanism **141**, and a second spring **148-B** configured to bias the second button **144-B** towards a first position corresponding to the first configuration of the constricting mechanism **141**. One or both of the first spring **148-A** and the second spring **148-B** can comprise a tension spring, compression spring, a torsion spring, a coil spring, or any other desired type of spring.

In some embodiments, one or both of the first spring **148-A** and the second spring **148-B** can generate sufficient force so as to allow actuation of the actuator **142** with a single hand and so as to collapse and seal the elongate member **132** when the constricting mechanism **141** is in the first configuration. In some embodiments, one or both of the first spring **148-A** and the second spring **148-B** can generate a force of: at least 0.1 pounds, at least 0.2 pounds, at least 0.3 pounds, at least 0.4 pounds, at least 0.5 pounds, at least 0.6 pounds, at least 0.7 pounds, at least 0.8 pounds, at least 0.9 pounds, at least 1 pound, at least 1.5 pounds, at least 2 pounds, at least 3 pounds, at least 5 pounds, and/or at least 10 pounds and in some embodiments one or both of the first spring **148-A** and the second spring **148-B** can generate a force approximately between: 0.1 and 10 pounds, 0.1 and 5 pounds, 0.1 and 1.5 pounds, 0.2 and 1 pounds, and/or 0.4 and 0.8 pounds.

The constricting mechanism **141** can include at least one filament **150** that extends at least partially around the elongate member **132**. In some embodiments, the at least one filament **150** can circumferentially constrict the elongate member **132** to collapse and seal the elongate member **132** when the constricting mechanism **141** is in the first configuration. The filament can be made from a variety of materials including, for example, a polymer, a synthetic, and/or a metal. In some embodiments, the filament **150** can be nylon, stainless steel, nitinol, silicone, or the like. In some embodiments, the filament can comprise a single strand such as, for example, a monofilament, and in some embodiments, the filament can comprise a plurality of strands that can be, for example, twisted, woven, grouped, and/or fused to form the filament. In some embodiments, the filament **150** can comprise one or several threads, lines, cords, rope, ribbon, flat wire, sheet, or tape.

The filament **150** can be coupled to the actuator **142** such that the filament **150** selectively constricts, collapses, and/or seals the elongate member **132**, and specifically the central lumen **138** of the elongate member **132** based on the movement and/or position of the actuator **142**. In some embodiments, the filament **150** can be connected to one or both of the buttons **144-A**, **144-B** such that the filament **150** collapses, constricts, and/or seals the elongate member **132** and specifically the central lumen **138** of the elongate member **132** when the buttons **144-A**, **144-B** are in the first position, and the filament **150** can be connected to one or both of the buttons **144-A**, **144-B** such that the elongate member **132** and specifically the central lumen **138** of the elongate member **132** is open and uncollapsed when the buttons **144-A**, **144-B** are in the second position. In some embodiments in which the actuator **142** comprises a single button **144**, as depicted in FIG. 5, the filament **150** can be connected to the button **144** and to the housing **128** such that the filament **150** is tightened when the button **144** moves to the first position.

In some embodiments, the at least one filament **150** can extend along an axis **152** that can be perpendicular to a central axis **154** of the elongate member **132** and/or of the apertures **124**, **126**. In some embodiments, the axis **152** of the at least one filament **150** can intersect and be perpendicular to the central axis **154** of the elongate member **132** and/or of the apertures **124**, **126**. In some embodiments, the actuator **142**, and specifically the buttons **144-A**, **144-B** can move along this axis **152** when moved from the first position to the second position.

In FIG. 3, an embodiment of the valve **104** with the constricting mechanism **141** in the second configuration is shown. As specifically shown, both of the first and second buttons **144-A**, **144-B** are in the second position, depressed into the retention features **140** of the housing **128**. In this second position, the filament **150** is loosened, thereby allowing the expansion of the elongate member **132** and the unsealing of the central lumen **138** of the elongate member **132**.

As further seen in FIG. 3, the proximal cap **116** has a proximal end **300** and a distal end **302**. The proximal cap **116** can include a funnel portion **301** of the proximal aperture **124**, which funnel portion **301** can facilitate insertion of a tool into the proximal aperture **124**. The distal end **302** of the proximal cap **116** can partially extend into the interior channel **130** of the housing **128**. The proximal cap **116** can include a mating feature **304** that can mate with the proximal end **134** of the elongate member **132**. In some embodiments, the proximal end **134** of the elongate member **132** can fit over the mating feature **304** of the proximal cap **116**. The

proximal end **134** of the elongate member **132** can be compressed between the mating feature **304** of the elongate member **132** and a portion of the interior channel **130** of the housing **128** into which the mating feature **304** is inserted to thereby secure the proximal end **134** of the elongate member **132** on the mating feature **304**. In some embodiments, the proximal end **134** of the elongate member **132** can be further secured on the mating feature **304** by a proximal O-ring **306** that can be compressed between the housing **128** and the mating feature **304** of the proximal cap **116** to sealingly couple the elongate member **132** to the proximal cap **116**.

The distal cap **120** has a proximal end **308** and a distal end **310**. The distal cap can include a mating feature **312** located on the proximal end **308** of the distal cap **120**, which mating feature **312** can mate with the distal end **136** of the elongate member **132**. In some embodiments, the distal end **136** of the elongate member **132** can fit over the mating feature **312** of the distal cap **123**. The distal end **136** of the elongate member **132** can be compressed between the mating feature **312** of the elongate member **132** and a portion of the interior channel **130** of the housing **128** into which the mating feature **312** is inserted to thereby secure the distal end **136** of the elongate member **132** on the mating feature **312**. In some embodiments, the distal end **136** of the elongate member **132** can be further secured on the mating feature **312** by a distal O-ring **314** that can be compressed between the housing **128** and the mating feature **312** of the proximal cap **116** to sealingly couple the elongate member **132** to the distal cap **120**.

The distal cap **120** can, in some embodiments, further include a side port barb **314** that can extend laterally away from the distal cap **120** and specifically away from the distal aperture **126** of the distal cap **120**. The side port barb **314** can define a side port channel **316** that can extend through the side port barb **314** and fluidly connect to the distal aperture **126**. In some embodiments, the side port barb **314** can include a securement feature **318** such as a barb that can secure coupling of a hose or tube to the side port barb **314**.

In some embodiments, the side barb **314** can be used to apply a vacuum to the portions of the delivery device **100**, and particularly to portions of the delivery device **100** that are distal of the axis **152** along which the elongate member **132** seals. This vacuum can be applied to aspirate a material through the delivery device **100**, and specifically through the catheter **102** of the delivery device. This aspirated material can be a biological material including, for example, bodily fluids, multi-phase bodily materials that can include, for example, a fluidic portion and at least one solid portion, or the like.

In some embodiments, due to the narrowing shape of the elongate member **132** when the constricting mechanism **141** is in the first configuration, a vacuum applied to the portions of the delivery device **100** distal to the axis **152** draws the elongate member **132** towards the first configuration and can, in some embodiments, increase the strength, robustness, and/or strength of the seal of the valve **104**. This attribute of the valve **104** can provide benefits over other valve designs in which a vacuum can compromise the seal of the valve, and thus the ability to draw a vacuum and aspirate can be limited.

In some embodiments, the valve **104** can further include a reinforcement structure **320** that can extend along all or portions of the elongate member **132**. The reinforcement structure **320** can facilitate the uniform collapse of the elongate member **132**, can prevent the at least one filament **150** from cutting through and/or tearing the elongate member **132**, and can assist in guiding one or several tools

11

through the elongate member 132. The reinforcement structure 320 can be tubular, can extend along and around the elongate member 132, and can be positioned so as to be between the elongate member 132 and the at least one filament 150.

The reinforcement structure 320 can include a proximal end 322 and a distal end 324. In some embodiments, the reinforcement structure 320 extends along and around the elongate member 132, and is positioned such that the proximal end 322 of the reinforcement structure 320 is proximate to the first end 134 of the elongate member 132 and the distal end 324 of the reinforcement structure 320 is proximate to the second end 136 of the elongate member 132.

The reinforcement structure 320 can be coupled to the elongate member 132. In some embodiments, the reinforcement structure 320 is coupled to the elongate member 132 along the length of the reinforcement structure 320, and in some embodiments, the reinforcement structure 320 is coupled to the elongate member 132 and distinct positions along the length of the elongate member 132 and/or the reinforcement structure 320. In one embodiment, for example, the reinforcement structure 320 can be coupled to the elongate member 132 at one or both of the proximal end 322 of the reinforcement structure 320 and the distal end 324 of the reinforcement structure 320 and/or at one or both of the first end 134 and the second end 136 of the elongate member 132. In some embodiments, the reinforcement structure 320 can be coupled to the elongate member 132 via one or several other components of the valve 104. In some embodiments, the reinforcement structure 320 can be coupled to the elongate member 132 via the compression of the reinforcement structure 320 and the elongate member 132 between the housing 128 and one or both of the proximal 116 and the distal 120.

In some embodiments, the reinforcement structure 320 can be adhered to the elongate member 132 via, for example, an adhesive such as silicone adhesive. In some embodiments, the adhesive can be circumferentially applied to the reinforcement structure 320 and/or the elongate member 132 in an adhesive ring that can, for example, have a length approximately between: 0.010 inches and 0.5 inches; 0.02 and 0.4 inches; 0.050 inches and 0.0250 inches, or any other or intermediate range.

In one embodiment, each of the proximal end 322 and the distal end 324 of the reinforcement structure 320 can be adhered via an adhesive to the elongate member 132. In such an embodiment, the reinforcement structure 320 may be uncoupled to the elongate member 132 at positions other than the coupling at one or both of the proximal end 322 and the distal end 324 of the reinforcement structure 320, and thus the reinforcement structure 320 is uncoupled to the elongate member 132 at a position between the first end 134 and the second end 136 of the elongate member 134 and/or between the proximal end 322 and the distal end 324 of the reinforcement structure 320.

The lack of coupling of the reinforcement structure 320 to the elongate member 132 can facilitate and improve the collapse of the elongate member 132 around a tool 400, also referred to herein as instrument 400 or device 400, inserted through the valve 104 as shown in FIG. 4. The tool 400 can be any device inserted through the valve 104 including, for example, one or several additional catheters, lines, wires, grippers, punches, cutters, or the like. As seen in FIG. 4, the tool 400 is inserted through the valve 104 and specifically through the elongate member 132 of the valve. As shown, the constricting mechanism 141 is in the first configuration

12

and the elongate member 132 and the central lumen 138 of the elongate member 132 is collapsed around the tool 400, and specifically around a shaft 402 of the tool 400 to thereby seal the valve 104 around the tool 400 and specifically around the shaft 402 of the tool 400. The constricting mechanism 141 can seal around tools 400 that fit through the elongate member 132, regardless of the size of the tool 400. Thus, the valve can be used with a wide variety of tools.

The reinforcement structure 320 can comprise a variety of designs, shapes, sizes, and materials. In some embodiments, the reinforcement structure 320 can be sized and shaped so as to receive elongate member 132 and to be positioned between the elongate member 132 and the at least one filament 150. In some embodiments, the reinforcement structure 320 can be made from a material sufficiently strong to prevent the cutting of the at least one filament 150 through the elongate member 132.

In some embodiments, the reinforcement structure can comprise a coil or a mesh sheath. The mesh sheath can, in some embodiments, comprise a braided mesh. The braided mesh can be made from any desired number of wires in any desired configuration. In some embodiments, the braided mesh can comprise a 4 wire braided mesh, an 8 wire braided mesh, a 12 wire braided mesh, a 16 wire braided mesh, a 20 wire braided mesh, a 24 wire braided mesh, a 32 wire braided mesh, a 48 wire braided mesh, a 64 wire braided mesh, a 72 wire braided mesh, an 80 wire braided mesh, a 96 wire braided mesh, or any other or intermediate braided mesh. In some embodiments, the braided mesh can comprise: a 1x1 configuration. In some embodiments, the wire in the braided mesh can be any desired material including, for example, a metal wire such as a nitinol wire or a stainless steel wire, a polymer wire, or a natural wire. In one embodiment, the braided mesh can comprise a 48 wire mesh in a 1x1 configuration made with a nitinol wire having a diameter of 0.003 inches.

With reference now to FIGS. 6 through 9, different embodiments and/or configurations of the filament 150 are shown. The filament 150 can comprise a single filament 150 having a first end 600 and a second end 602 as shown in FIG. 6. The filament 150, and specifically which first and second ends 600, 602 can be coupled to the actuator 142 to move the filament 150 between the first and second configurations or positions and/or from the first configuration or position to the second configuration or position. In some embodiments, both of the first end 600 and the second end 602 can be coupled to a single button 144, in some embodiments, each of the first end 600 and the second end 602 can be coupled to different buttons 144, and in some embodiments, one of the first end 600 and the second end 602 can be coupled to a button 144 and the other of the first end 600 and the second end 602 can be coupled to the housing 128 or other portion of the valve 104.

In some embodiments, the filament 150 can comprise multiple filaments, and specifically, as shown in FIGS. 7 through 9, the filament 150 can comprise a first filament 150-A and a second filament 150-B. In embodiments in which the filament 150 comprises multiple filaments, each of the multiple filaments can have a first end 700 and a second end 702. The first and second filaments 150-A, 150-B can be coupled to the actuator 142. In such embodiments, the first and second ends 700, 702 can be coupled to the actuator 142 to move the filaments 150-A, 150-B between the first and second configurations and/or from the first configuration to the second configuration. In some embodiments, both of the first end 700 and the second end 702 of one or more of the multiple filaments 150 can be

13

coupled to a single button **144**, in some embodiments, each of the first end **700** and the second end **702** of one or more of the multiple filaments **150** can be coupled to different buttons **144**, and in some embodiments, one of the first end **700** and the second end **702** of one or more of the multiple filaments **150** can be coupled to one button **144** and the other of the first end **700** and the second end **702** of those one or more filaments **150** can be coupled to the housing **128** or other portion of the valve **104**.

The filament **150** can be arranged in a variety of configurations. In some embodiments, the filament **150** can be configured to form a single loop **604** that can extend around the elongate member **132** and/or through which the elongate member **132** can be received as shown in FIG. 6, and in some embodiments, the filament **150** can be configured to form multiple loops, and specifically a first loop **704** and a second loop **706** as shown in FIG. 7. The first and second loops **704**, **706** can each receive the elongate member **132**. In some embodiments, a diameter or size of the loop **604**, or of the loops **704**, **706** can decrease when the constricting mechanism **141** is moved from the second configuration to the first configuration.

In some embodiments, the filament **150** can be configured to form a bight **800**, which bight **800** can be a single bight or multiple bights. As used herein, a “bight” refers to a U-shaped section between the two ends of the filament **150**. As depicted in FIGS. 8 and 9, the bight **800** can comprise multiple bights, and specifically a first bight **800-A** and a second bight **800-B**. In some embodiments, the first bight **800-A** can extend through the second bight **800-B** such that the first and second bights **800-A**, **800-B** interlock, whereas in other embodiments, the first and second bights **800-A**, **800-B** can be non-interlocking. Similarly, in embodiments containing the filament **150** having multiple loops, one or several of the multiple loops can be interlocking.

In some embodiments, the bight **800**, and specifically one or both of the first bight **800-A** and the second bight **800-B** can be formed around a portion of the elongate member **132** and/or can extend around a portion of the elongate member **132**. Each bight **800** can define a partially enclosed receiving area **808** wherein the elongate member **132** can be received. Thus, the first bight **800-A** can define a first receiving area **808-A** and the second bight **800-B** can define a second receiving area **808-B**.

As seen in FIGS. 8 and 9, multiple bights, and specifically the first and the second bights **800-A**, **800-B** can be positioned and oriented such that the first bight **800-A** has a first orientation or first direction as indicated by arrow **810**, and the second bight has a second orientation or second direction as indicated by the arrow **812**. In some embodiments, the first orientation is different from the second orientation such that the first and second receiving areas **808-A**, **808-B** overlap and define an encircled area **814**, also referred to herein as a constricting area **814**. The elongate member **132** can be received within the encircled area **814**. In embodiments in which bights **800-A**, **800-B** overlap to define the encircled area **814**, the movement of the constricting mechanism **141** to the first configuration can result in and/or include the first bight **800-A** moving in the direction indicated by the arrow **810** and/or the second bight **800-B** moving in the direction indicated by the arrow **812**, which movement of the bights **800-A**, **800-B** decreases the size of the encircled area **814** and constricts, collapses, and/or seals the elongate member **132** extending through the encircled area **814**.

The filament(s) **150** forming the bights **800** can each apply an arcuate line or narrow longitudinal zone of pressure

14

to the elongate member **132**. If the filament(s) are circular in cross-section, the zone of pressure can be very small, and can, in some embodiments, be less than the diameter or thickness of the filament. In some embodiments, the filaments have a diameter or width less than about 2.5 mm, less than about 2 mm, less than about 1.5 mm, less than about 1.25 mm, less than about 1 mm, less than about 0.75 mm, less than about 0.5 mm, and/or less than about 0.25 mm. In some embodiments, the filaments can have a diameter or width of between about 0.01 mm and 2.5 mm, between about 0.05 mm and 2 mm, between about 0.1 mm and 1 mm, and/or between about and 0.70 mm. In some embodiments, the arcuate line or zone of pressure may form two opposing arcs and in other embodiments, the arcuate line of pressure may be a singular substantially circular line or zone that encircles the elongate member at least once. The longitudinal length of the of the line or zone of pressure may be very short compared to other valves known in the art. In some embodiments, the longitudinal length of the zone of pressure applied to the elongate member **132** by the filament(s) **150** may be less than about 2.0 mm and in some embodiments less than about 0.5 mm. In some embodiments, the filament(s) **150** can have any desired cross-sectional shape including, for example, a circular cross-section, a rectangular cross-section, an oval cross-section, a square cross-section, a polygonal cross-section, a triangular cross-section, or any other desired shape of cross-section.

With reference now to FIG. 10, a flowchart illustrating one embodiment of a process **1000** for sealing a valve **104** and/or catheter **102** accessing a body of a patient is shown. The process **1000** can be performed using the valve **104** and/or the delivery system **100**. The process **1000** begins at block **1002**, wherein the delivery device **100**, and specifically the catheter **102** of the delivery device **100** is inserted into the body of the patient. In some embodiments, this can include inserting the catheter **102** into a portion of the circulator system of the patient such as, for example, a blood vessel including an artery or a venous vessel. In some embodiments, the delivery device **100** can be inserted into the body of the patient directly through an aperture or incision in the patient, and in some embodiments, the delivery device **100** can be inserted into the body of the patient via another catheter or device. In some embodiments, the constricting mechanism **141** can be in the first configuration while the delivery device **100** and/or the catheter **102** is inserted into the patient's body.

After the delivery device **100** is inserted into the body of the patient, the process **1000** proceeds to block **1004**, wherein the constricting mechanism **141** is moved from the first configuration to the second configuration. As described above, the central lumen **138** of the elongate member **132** is unsealed when the constricting mechanism **141** is in the second configuration. In some embodiments, the moving of the constricting mechanism **141** from the first configuration to the second configuration can include the manipulation of the actuator **142** and/or the control of the actuator **142**, and specifically the depressing of the one or several buttons **144** to move the filament **150** from the first position to the second position to allow the expansion and opening of the central lumen **138** of the elongate member **132**.

After the constricting mechanism **141** is moved from the first configuration to the second configuration, the process **1000** proceeds to block **1006**, wherein the tool **400**, and specifically the shaft **402** of the tool **400** is advanced through the delivery device **100** and specifically through the valve **104** until a first end of the tool reaches a desired position within the body of the patient. In some embodiments, a

15

portion of the shaft 402 can be positioned within the central lumen 138 of the elongate member 132 after the advancing of the tool 400 through the delivery device 100. In some embodiments, after the tool 400 is advanced through the delivery device 100, the desired procedure can be performed with the tool.

After the tool 400 is advanced through the delivery device 100, or while the tool 400 is being advanced through the delivery device 100, the process 1000 proceeds to block 1008, wherein the constricting mechanism 141 is returned to the first configuration. In some embodiments, the returning of the constricting mechanism 141 to the first configuration can include the release of the one or several buttons 144 and/or the control of the actuator 142 to reconfigure the constricting mechanism 141 to the first configuration. In some embodiments, the return of the constricting mechanism 141 to the first configuration can result in the collapse and/or sealing of the elongate member 132 and specifically the central lumen 138 of the elongate member 132 around the tool 400 and specifically around the shaft 402 of the tool 400. The return of the constricting mechanism 141 to the first configuration, or the movement of the constricting mechanism 141 to the first configuration can include the decreasing of the size and/or diameter of one or several loops formed by the filament 150 and/or the movement of one or several bights 800 such as, for example, the movement of the first bight 800-A in the first direction indicated by arrow 810 and the movement of the second bight 800-B in the second direction indicated by arrow 812 to reduce the size of the constricting area 814. In some embodiments, after the constricting mechanism is returned to the first configuration, the desired procedure can be performed with the tool.

After the constricting mechanism is returned to the first configuration, the process 1000 proceeds to block 1010, wherein the tool 400, and specifically the shaft 402 of the tool 400 is retracted from the delivery device 100, and more specifically from the valve 104. In some embodiments, the valve 104 can remain sealed during the retracting of the tool 400 and/or the shaft 402 of the tool. In some embodiments, the valve 104 remains sealed during the retracting of the tool 400 and/or the retracting of the shaft 402 of the tool 400 as the constricting mechanism 141 can remain in the first configuration during the retracting of the tool 400 and/or the shaft 402 of the tool 400.

In some embodiments, the constricting mechanism 141 can be moved to the second configuration to allow the retraction of the tool 400 and/or the shaft 402 of the tool 400 from the valve 104, and the constricting mechanism 141 can be returned to the first configuration when the tool 400 and/or the shaft 402 of the tool 400 is removed from the valve 104. In some embodiments, the retraction of the tool 400 and/or shaft 402 of the tool 400 from the valve 104 can be performed with the constricting mechanism 141 left in the first configuration. In some embodiments, the constricting mechanism 141 can be moved to the second configuration, and then returned to the first configuration via the manipulation and/or control of the actuator 142, which manipulation and/or control of the actuator 142 can include the depressing of the one or several buttons 144 to move the constricting mechanism 141 to the second configuration, and the release of the one or several buttons 144 to return the constricting mechanism 141 to the first configuration. In some embodiments, if the procedure is complete, the delivery device 100 can then be removed from the body of the patient, and any incision created for the procedure can be closed.

16

With reference now to FIG. 11, a side view of one embodiment of a thrombectomy system 1100 including the delivery device 100 and a thrombus extraction device 1102 is shown. In some embodiments, the thrombectomy system 1100 can be used to access a blood vessel 1104 to treat and/or extract a thrombus 1106 from the blood vessel 1104. The thrombus extraction device 1102 can include a self-expanding coring element 206 and expandable cylindrical portion 208. In some embodiments, and as shown in FIG. 11, the thrombus extraction device 1102 can be the tool 400 that can extend through the valve 104, and in some embodiments, the valve 104 can be a part of the thrombus extraction device 1102. Further details of thrombectomy systems, thrombus extraction devices, and methods of using the same are disclosed in: U.S. application Ser. No. 15/268,296, filed Sep. 16, 2016, and entitled "INTRAVASCULAR TREATMENT OF VASCULAR OCCLUSION AND ASSOCIATED DEVICES, SYSTEMS, AND METHODS"; U.S. application Ser. No. 15/498,320, filed Apr. 26, 2017, and entitled "DEVICES AND METHODS FOR TREATING VASCULAR OCCLUSION"; and U.S. application Ser. No. 15/466,740, filed on Mar. 22, 2017, and entitled "DEVICE AND METHOD FOR TREATING VASCULAR OCCLUSION", the entirety of each of which is hereby incorporated by reference herein.

With reference now to FIG. 12, a side-section view of another embodiment of the hemostasis valve 104 having two piece caps 116, 120 is shown. The valve 104 can include a housing 128 defining an interior channel 130 through which the tubular member 132 can extend. The valve 104 can include the proximal cap 116 and the distal cap 120. In some embodiments, the proximal cap 116 can comprise a two piece cap and can include a proximal exterior member 1200 and a proximal channel member 1202. In some embodiments, the distal cap 120 can comprise a two-piece cap and can include a distal exterior member 1204 and a distal channel member 1206. In some embodiments, this coupling between the proximal exterior member 1200 and the proximal channel member 1202 and/or the coupling between the distal exterior member 1204 and the distal channel member 1206 can be a sealed coupling so as to prevent the leakage of material including fluid or gas between the respective ones of the proximal exterior member 1200 and the proximal channel member 1202 and/or the distal exterior member 1204 and the distal channel member 1206. In some embodiments, this sealing coupling can be achieved and/or maintained via a seal such as an 1208 that can be positioned between the proximal exterior member 1200 and the proximal channel member 1202 and/or between the distal exterior member 1204 and the distal channel member 1206.

In some embodiments, the proximal exterior member 1200 can be coupled, and in some embodiments, rotatably coupled to the proximal channel member 1202 in a manner to allow the rotation of the proximal exterior member 1200 without rotating the proximal channel member 1202. Similarly, in some embodiments, the distal exterior member 1204 can be rotatably coupled to the distal channel member 1206 in a manner to allow the rotation of the distal exterior member 1204 without the rotating of the distal channel member 1206. In some such embodiments, the channel members 1202, 1206 can be non-rotatable with respect to the housing 128 and/or the tubular member 132, and one or both of the exterior members 1200, 1204 can be rotatable with respect to the housing 128 and/or the tubular member 132. In such an embodiment, the maintaining of the rotational position of the channel members 1202, 1206 with respect to the housing 128 and/or the tubular member 132 can prevent

17

the twisting of the tubular member **132** which can result in the sealing of the tubular member **132** regardless of the configuration of the constructing mechanism **141**.

The exterior members **1200**, **1204** can comprise a variety of shapes and sizes and can include a variety of features. In some embodiments, one or both of the exterior members **1200**, **1204** can be coupled to, for example, a shaft similar to the shaft **106** shown in FIG. **1**. In some embodiments, for example, the distal exterior member **1204** can be coupled to a shaft **106**, including, for example, can be non-detachably coupled to the shaft **106**. In some embodiments, one or both of the exterior members can include one or several features configured to facilitate coupling with the valve **104**. These one or several features can include, for example, one or several male or female: connectors; couplers; attachment mechanisms; or the like. In some embodiments, these one or several features can facilitate use of the valve with other existing components, instruments, tools, or the like. In some embodiments, for example, one or both of the exterior members **1200**, **1204** can comprise either a male or female luer fitting, and specifically as shown in FIG. **12**, the distal exterior member **1204** can comprise a male luer fitting **1210**.

Several aspects of the present technology are set forth in the following examples.

1. A hemostatic valve for sealing a medical device, the hemostatic valve comprising:
an elongate member having a first end, a second end, and a central lumen extending therebetween, wherein the elongate member is pliable;
a reinforcement structure extending along at least a portion of the elongate member, wherein the reinforcement structure is coupled to the elongate member; and
an active tensioning mechanism coupled to the elongate member, wherein the tensioning mechanism is moveable between a first configuration wherein the central lumen is constricted and sealed and a second configuration wherein the central lumen is open.
2. The hemostatic valve of example 1, wherein the elongate member comprises a compliant polymer tube.
3. The hemostatic valve of example 1 or 2, wherein the tensioning mechanism comprises at least one filament extending at least partially around the elongate member.
4. The hemostatic valve of example 3, wherein the reinforcement structure is positioned between the at least one filament and the elongate member.
The hemostatic valve of example 4, wherein the reinforcement structure comprises a braided mesh.
6. The hemostatic valve of example 4 or 5, wherein the reinforcement structure is coupled to the elongate member at a position proximate to the first end of the elongate member and at a position proximate to the second end of the elongate member.
7. The hemostatic valve of example 6, wherein the reinforcement structure is not coupled to the elongate member at a position between the first end of the elongate member and the second end of the elongate member.
8. The hemostatic valve of any one of examples 3-7, wherein the tensioning mechanism comprises an actuator coupled to the at least one filament, wherein the actuator is moveable to control movement of the at least one filament from a first position wherein the central lumen is constricted and sealed to a second position wherein the central lumen is open, wherein the at least one filament is in the first position when the tensioning mechanism is in the first configuration.

18

9. The hemostatic valve of example 8, wherein the actuator is biased towards the first position.
10. The hemostatic valve of example 8 or 9, wherein the actuator is biased toward the second position.
11. The hemostatic valve of any one of examples 8-10, wherein the actuator comprises a manual actuator.
12. The hemostatic valve of any one of examples 8-11, wherein the at least one filament forms a loop around the elongate member.
13. The hemostatic valve of any one of examples 8-12, wherein the at least one filament forms a bight around a portion of the elongate member.
14. The hemostatic valve of any one of examples 8-13, wherein the at least one filament comprises a first filament and a second filament, wherein each of the first filament and the second filament are coupled to the actuator, and wherein the first filament and the second filament are moveable from the first position to the second position.
15. The hemostatic valve of example 14, wherein each of the first filament and the second filament form a loop around the elongate member.
16. The hemostatic valve of example 14 or 15, wherein the first filament forms a first bight around a first portion of the elongate member, and wherein the second filament forms a second bight around a second portion of the elongate member.
17. The hemostatic valve of example 16, wherein the first bight extends through the second bight.
18. The hemostatic valve of any one of examples 1-17, further comprising a shell defining a first aperture and a second aperture, wherein the elongate member extends from the first aperture to the second aperture and fluidly couples the first aperture and the second aperture.
19. The hemostatic valve of any one of examples 1-18, wherein the tensioning mechanism is self-adjustable to seal around tools of different sizes extending through the hemostatic valve.
20. The hemostatic valve of any one of examples 1-19, wherein the central lumen comprises a single lumen.
21. The hemostatic valve of any one of examples 1-20, wherein the central lumen comprises a plurality of lumens.
22. A delivery system for intravascular access of a blood vessel within a patient's body, the delivery system comprising:
a catheter having a first end, a second end, and a catheter lumen extending therebetween;
a hemostatic valve coupled to the first end of the catheter, the hemostatic valve comprising:
a tubular member having a first end, a second end, and a central lumen extending therebetween, wherein the central lumen of the tubular member is fluidly coupled with the catheter lumen; and
an active tensioning mechanism coupled to the tubular member, the tensioning mechanism moveable between a first configuration wherein the tensioning mechanism constricts on the central lumen and the central lumen is sealed and a second configuration wherein the central lumen is open.
23. The delivery system of example 22, wherein the hemostatic valve further comprises a reinforcement structure extending along at least a portion of the tubular member.

19

24. The delivery system of example 22 or 23, wherein the reinforcement structure is located between the tensioning mechanism and the tubular member.
25. The delivery system of example 24, wherein the reinforcement structure comprises a braided mesh. 5
26. The delivery system of example 24 or 25, wherein the reinforcement structure is coupled to the tubular member at a position proximate to the first end of the tubular member and at a position proximate to the second end of the tubular member. 10
27. The delivery system of example 26, wherein the reinforcement structure is adhered to the tubular member at the first end of the tubular member and at the second end of the tubular member. 15
28. The delivery system of example 27, wherein the reinforcement structure is uncoupled to the tubular member between the first end of the tubular member and the second end of the tubular member.
29. The delivery system of any one of examples 22-28, wherein the tensioning mechanism comprises at least one filament extending at least partially around the tubular member. 20
30. The delivery system of example 29, wherein the tensioning mechanism comprises an actuator coupled to the at least one filament, wherein moving the tensioning mechanism from the first configuration to the second configuration comprises moving the actuator and the thereto coupled at least one filament from a first position to a second position, wherein the filament constricts and seals the central lumen of the tubular member when the filament is in the first position. 30
31. The delivery system of example 30, wherein the actuator comprises a manual actuator.
32. The delivery system of example 31, wherein the actuator comprises a pair of opposing and depressable buttons, wherein the buttons are biased towards an undepressed position. 35
33. The delivery system of example 31 or 32, wherein the central lumen is sealed when the buttons are in the undepressed position. 40
34. The delivery system of any one of examples 30-33, wherein the filament comprises a monofilament.
35. The delivery system of any one of examples 30-34, wherein the filament comprises at least one of: a polymer filament; or a metallic filament. 45
36. The delivery system of any one of examples 22-35, wherein the catheter comprises a thrombus extraction device.
37. A method of sealing a delivery device accessing a blood vessel of a patient, the method comprising: 50
 inserting the delivery device comprising a catheter and a hemostatic valve into the blood vessel of the patient, the catheter having a first end, a second end, and a catheter lumen extending therethrough, and the hemostatic valve coupled to the first end and having a tubular member defining a central lumen fluidly coupled with the catheter lumen and a tensioning mechanism coupled with the tubular member, wherein the tensioning mechanism collapses and seals the central lumen in a first configuration and thereby seals access to the blood vessel; 60
 moving the tensioning mechanism of the hemostatic valve to a second configuration, wherein the central lumen is open and access to the blood vessel is unsealed when the tensioning mechanism is in the second configuration; 65

20

- advancing a shaft of a tool through the delivery device until a first end of the tool reaches a desired position within the blood vessel of the patient and a portion of the shaft is positioned within the central lumen of the tubular member; and
 returning the tensioning mechanism of the hemostatic valve to the first configuration such that the tubular member collapses on the shaft of the tool and seals around the shaft of the tool.
38. The method of example 37, further comprising retracting the shaft of the tool from the delivery device.
39. The method of example 38, wherein the tensioning mechanism is maintained in the first configuration during and after the retracting of the shaft of the tool from the delivery device.
40. The method of example 38 or 39, wherein the tensioning mechanism is moved to the second configuration during the retracting of the shaft of the tool from the delivery device, and wherein the tensioning mechanism is returned to the first configuration after the shaft of the tool is retracted from the delivery device.
41. The method of any one of examples 37-40, wherein the tensioning mechanism comprises at least one filament extending at least partially around the tubular member, wherein the at least one filament collapses the tubular member when the tensioning mechanism is in the first configuration.
42. The method of example 41, wherein the at least one filament circumferentially constricts the tubular member to collapse the tubular member when the tensioning mechanism is in the first configuration.
43. The method of example 41 or 42, wherein the hemostatic valve comprises a reinforcement structure located between the at least one filament and the tubular member.
44. The method of any one of examples 41-43, wherein the at least one filament forms a loop around the elongate member, and wherein moving the tensioning mechanism from the second configuration to the first configuration reduces a size of the loop to thereby constrict the tubular member within the loop.
45. The method of any one of examples 41-44, wherein the filament forms at least one bight around a portion of the elongate member.
46. The method of example 45, wherein the filament comprises a first filament and a second filament, and wherein the at least one bight comprises a first bight oriented in a first direction and formed by the first filament and a second bight oriented in a second direction and formed by the second filament, wherein the first and second bights overlap to encircle a portion of the tubular member within a constricting area.
47. The method of example 46, wherein moving the tensioning mechanism from the second configuration to the first configuration comprises moving the first bight in the first direction and the second bight in the direction to reduce the size of the constricting area and collapse and seal the central lumen of the tubular member.
48. The method of any one of examples 37-47, wherein the tensioning mechanism comprises an actuator, and wherein moving the tensioning mechanism to the second configuration comprises manipulating the actuator.
49. The method of any one of examples 37-48, further comprising applying a vacuum to the delivery device to aspirate material through the catheter, wherein the central lumen remains sealed during the aspiration.

21

50. The method of any one of examples 37-49, wherein the tool comprises a thrombus extraction device.

51. A hemostatic valve for sealing a medical device, the hemostatic valve comprising:

an elongate member having a first end, a second end, and a central lumen comprising a plurality of lumens extending therebetween, wherein the elongate member is pliable; and

an active tensioning mechanism coupled to the elongate member, wherein the tensioning mechanism is moveable between a first configuration wherein the central lumen is constricted and sealed and a second configuration wherein the central lumen is open.

Other variations are within the spirit of the present invention. Thus, while the invention is susceptible to various modifications and alternative constructions, certain illustrated embodiments thereof are shown in the drawings and have been described above in detail. It should be understood, however, that there is no intention to limit the invention to the specific form or forms disclosed, but on the contrary, the intention is to cover all modifications, alternative constructions, and equivalents falling within the spirit and scope of the invention, as defined in the appended claims.

In the previous description, various embodiments of the present invention are described. For purposes of explanation, specific configurations and details are set forth in order to provide a thorough understanding of the embodiments. However, it will also be apparent to one skilled in the art that the present invention may be practiced without the specific details. Furthermore, well-known features may be omitted or simplified in order not to obscure the embodiment being described.

The use of the terms “a” and “an” and “the” and similar referents in the context of describing the invention (especially in the context of the following claims) are to be construed to cover both the singular and the plural, unless otherwise indicated herein or clearly contradicted by context. The terms “comprising,” “having,” “including,” and “containing” are to be construed as open-ended terms (i.e., meaning “including, but not limited to,”) unless otherwise noted. The term “connected” is to be construed as partly or wholly contained within, attached to, or joined together, even if there is something intervening. Recitation of ranges of values herein are merely intended to serve as a shorthand method of referring individually to each separate value falling within the range, unless otherwise indicated herein, and each separate value is incorporated into the specification as if it were individually recited herein. All methods described herein can be performed in any suitable order unless otherwise indicated herein or otherwise clearly contradicted by context. The use of any and all examples, or exemplary language (e.g., “such as”) provided herein, is intended merely to better illuminate embodiments of the invention and does not pose a limitation on the scope of the invention unless otherwise claimed. No language in the specification should be construed as indicating any non-claimed element as essential to the practice of the invention.

Preferred embodiments of this invention are described herein, including the best mode known to the inventors for carrying out the invention. Variations of those preferred embodiments may become apparent to those of ordinary skill in the art upon reading the foregoing description. The inventors expect skilled artisans to employ such variations as appropriate, and the inventors intend for the invention to be practiced otherwise than as specifically described herein. Accordingly, this invention includes all modifications and equivalents of the subject matter recited in the claims

22

appended hereto as permitted by applicable law. Moreover, any combination of the above-described elements in all possible variations thereof is encompassed by the invention unless otherwise indicated herein or otherwise clearly contradicted by context.

All references, including publications, patent applications, and patents, cited herein are hereby incorporated by reference to the same extent as if each reference were individually and specifically indicated to be incorporated by reference and were set forth in its entirety herein.

What is claimed is:

1. A valve, comprising:

an elongate member defining a lumen;

an active tensioning mechanism including an actuator coupled to the elongate member via a filament extending at least partially around the elongate member, wherein the actuator is moveable between (a) a first position wherein the lumen is constricted and sealed and (b) a second position wherein the lumen is at least partially open; and

a biasing member configured to bias the actuator to the first position.

2. The valve of claim 1 wherein the elongate member is pliable.

3. The valve of claim 1 wherein the filament extends in a loop around the elongate member.

4. The valve of claim 1 wherein the actuator is a button, wherein the button is undepressed in the first position, and wherein the button is depressed in the second position.

5. The valve of claim 1 wherein, when the actuator is in the first position, the lumen is configured to remain constricted and sealed when a pressure differential exists between (a) a first volume outside the lumen and adjacent to a first end of the elongate member and (b) a second volume outside the lumen and adjacent to a second end of the elongate member.

6. The valve of claim 1 wherein, when the actuator is in the first position, the lumen is configured to remain constricted and sealed when vacuum pressure is applied to a volume outside the lumen and adjacent to either a first end or a second end of the elongate member.

7. The valve of claim 1 wherein the lumen extends a long a first longitudinal axis, wherein the actuator is movable between the first and second positions along a second longitudinal axis, and wherein the first longitudinal axis is orthogonal to the second longitudinal axis.

8. The valve of claim 1 wherein the biasing member is a compression spring.

9. The valve of claim 1 wherein, in the first position, the actuator pulls the filament to circumferentially constrict the elongate member such that the lumen is constricted and sealed.

10. The valve of claim 1 wherein the actuator is a first actuator, wherein the filament is a first filament, wherein the biasing member is a first biasing member, and wherein the active tensioning mechanism further comprises:

a second actuator coupled to the elongate member via a second filament extending at least partially around the elongate member, wherein the second actuator is moveable between (a) a first position wherein the lumen is constricted and sealed and (b) a second position wherein the lumen is at least partially open; and

a second biasing member configured to bias the second actuator to the first position.

11. The valve of claim 10 wherein the first filament has a first end portion coupled to the first actuator and a second end portion coupled to the first actuator, and wherein the

23

second filament has a first end portion coupled to the second actuator and a second end portion coupled to the second actuator.

12. The valve of claim 11 wherein the first filament and the second filament at least partially overlap to define a constricting region about the elongate member.

13. The valve of claim 12 wherein, when the second actuator is moved to the second position and/or the second actuator is moved to the second position, a size of the constricting region increases.

14. The valve of claim 10 wherein the first filament extends in a loop around the elongate member, and wherein the second filament extends through the loop of the first filament around the elongate member.

15. A valve, comprising:
an elongate member defining a lumen;
a filament coupled to the elongate member;
an actuator coupled to the filament, wherein the actuator is moveable between (a) a first position wherein the lumen is constricted and sealed and (b) a second position wherein the lumen is at least partially open; and
a biasing member configured to bias the actuator to the first position.

16. The valve of claim 15 wherein the filament extends at least partially around the elongate member.

17. The valve of claim 16 wherein, in the first position, the actuator pulls the filament to circumferentially constrict the elongate member such that the lumen is constricted and sealed.

18. The valve of claim 15 wherein the elongate member is pliable.

19. The valve of claim 15 wherein the filament is monofilament.

20. The valve of claim 15 wherein the actuator is a button that is undepressed in the first position and depressed in the second position, wherein the button is movable between the first and second positions along a first longitudinal axis, wherein the lumen extends a long a second longitudinal axis, and wherein the first longitudinal axis is orthogonal to the second longitudinal axis.

24

21. A valve, comprising:
an elongate member defining a lumen;
a filament coupled to the elongate member; and
an actuator coupled to the elongate member, wherein the actuator is moveable between

(a) a first position in which the actuator pulls the filament to collapse the elongate member such that the lumen is constricted and sealed and

(b) a second position wherein the lumen is at least partially open;

a biasing member configured to bias the actuator to the first position.

22. The valve of claim 21 wherein the elongate member is pliable, and wherein the filament extends at least partially around the elongate member.

23. The valve of claim 21 wherein the elongate member is pliable, and wherein the filament is looped around the elongate member.

24. The valve of claim 21 wherein the actuator does not substantially pull the filament in the second position such that the elongate member can expand.

25. A valve, comprising:
an elongate member defining a lumen; and
an active tensioning mechanism including a first actuator coupled to the elongate member via a first filament and a second actuator coupled to the elongate member via a second filament,

wherein the first filament and the second filament at least partially overlap to define a constricting region, wherein the elongate member extends through the constricting region, and

wherein the first actuator and/or the second actuator is moveable between (a) a first position in which the constricting region has a decreased size such that the lumen is constricted and sealed and (b) a second position in which the constricting region has an increased size such that the lumen is at least partially open.

26. The valve of claim 25, further comprising at least one biasing member configured to bias the first actuator and/or the second actuator to the first position.

* * * * *