

UNITED STATES PATENT AND TRADEMARK OFFICE

---

BEFORE THE PATENT TRIAL AND APPEAL BOARD

---

ACTIVISION BLIZZARD, INC.,  
Petitioner,

v.

MILESTONE ENTERTAINMENT, LLC,  
Patent Owner.

---

IPR2025-00709  
U.S. Patent No. 10,650,635 B2

---

Before SCOTT A. DANIELS, JAMES A. TARTAL, and  
SCOTT C. MOORE, *Administrative Patent Judges*.

DANIELS, *Administrative Patent Judge*.

DECISION  
Granting Institution of *Inter Partes* Review  
35 U.S.C. § 314

## I. INTRODUCTION

Activision Blizzard, Inc., (“Activision,” or “Petitioner”), filed a Corrected Petition requesting *inter partes* review (“IPR”) of claims 1, 2, 4, 6, 8–10, 14–18, 21–23, 25, 27, and 29 of U.S. Patent No. 10,650,635 B2 (Ex. 1001, “the ’635 patent”). Paper 3 (“Pet.”). Milestone Entertainment, LLC (“Milestone” or “Patent Owner”) filed a Preliminary Response to the Petition. Paper 10 (“Prelim. Resp.”).

Under 35 U.S.C. § 314(a), an *inter partes* review may not be instituted “unless . . . there is a reasonable likelihood that the petitioner would prevail with respect to at least 1 of the claims challenged in the petition.” Upon consideration of the arguments and evidence presented by Petitioner and Patent Owner, we are persuaded that Petitioner demonstrates a reasonable likelihood that it would prevail in showing the unpatentability of at least one of the challenged claims. *See* 35 U.S.C. § 314(a). Accordingly, we institute an *inter partes* review of the challenged claims.

## II. BACKGROUND

### *A. Real Parties in Interest*

Petitioner identifies Activision Blizzard, Inc., “a wholly owned subsidiary of Microsoft Corporation,” as the real party in interest. Pet. 2. Patent Owner identifies Milestone Entertainment, LLC as the real party in interest. Paper 4, 2.

### *B. Related Matters*

The parties indicate that the ’635 patent has been asserted in *Milestone Entertainment, LLC v. Activision Blizzard, Inc.*, 2:24-cv-04056 (C.D. Cal.). Pet. 2, Paper 4, 2.

Petitioner also identifies that it has challenged the following “related family members.” Pet. 2.

U.S. Patent No.	IPR
8,529,336	IPR2025-00708
10,825,294	IPR2025-00710
11,335,164	IPR2025-00711
11,393,279	IPR2025-00712
11,501,607	IPR2025-00713

*C. The '635 Patent (Ex. 1001)*

The '635 patent, titled “System for Implementing Enhanced Gaming and Prizing Parameters in an Electronic Environment,” relates to ways to effect user experience in electronic games using virtual currency. Ex. 1001, code 54, Abstract. The '635 patent was filed October 7, 2019, and claims priority through a series of continuations to U.S. Patent 8,241,110, filed September 1, 2004. *Id.* codes 22, 63. The '635 patent broadly describes “[s]ystems, apparatus and methods . . . for enhanced electronic entertainment, such as game play, over remote communications networks.” *Id.* at 1:25–28.

Of particular interest in this proceeding, the '635 patent describes enhancing the user’s game play experience with special forms of money or value where “[t]he games may be played either with real money, or may be played with virtual money, sometimes referred to as vCoins.” *Id.* at 45:58–60. The '635 patent describes embodiments where the user can acquire virtual money such as vCoins through game play or cash purchase and that “vCoins provide the player with the perception of a big win since the numbers are larger than any corresponding monetary amount.” *Id.* at 46:41–43. In addition, the '635 Patent explains that “by being virtual and corresponding to electronic amounts, [vCoins] may be altered or varied as desired.” *Id.* at 46:43–45.

*D. Illustrative Claim*

Claim 1 is independent. Claims 2, 4, 6, 8–10, 14–18, 21–23, 25, 27, and 29 depend directly or indirectly from claim 1. Claim 1 is reproduced below with the limitation identifiers referenced in the Petition (Pet. 13–24) and with particular limitations of interest highlighted in italics:

1. [Preamble] A system for effecting user experience on a user communication device in a multi-level electronic game environment comprising:

[1.a] memory storing information on game play, the information including input received from the user, information relating to levels within the multi-level game and game display information for output to the user,

[1.b] a processor coupled to the memory generating game play information,

[1b.i] *the game play information including game play with virtual money,*

[1.b.ii] the virtual money being acquired through:

[1.b.ii.A] (1) game play and

[1.b.ii.B] (2) cash purchase,

[1.b.iii] the virtual money acquired by cash purchase being subject to a multiplier,

[1.b.iv] *conversion of the virtual money into a non-cash good comprising an image to permit advancement to another level within the game,* and

[1.c] memory storing account information which is increased and decreased through the user experience.

Ex. 1001, 46:61–47:14 (emphases added).

*E. Prior Art and Asserted Grounds*

Petitioner asserts that claims 1, 2, 4, 6, 8–10, 14–18, 21–23, 25, 27, and 29 would have been unpatentable based on the following grounds:<sup>1</sup>

<b>Ground</b>	<b>Claim(s) Challenged</b>	<b>35 U.S.C. §</b>	<b>Reference(s)/Basis</b>
1	1, 2, 4, 6, 8–10, 14–18, 21–23, 25, 27, 29	103(a) <sup>2</sup>	Schneier, <sup>3</sup>
2	1, 2, 4, 6, 8–10, 14–18, 21–23, 25, 27, 29	103(a)	Schneier, Okita, <sup>4</sup>

III. PATENTABILITY ANALYSIS

A patent claim is unpatentable under 35 U.S.C. § 103(a) if the differences between the claimed subject matter and the prior art are such that the subject matter, as a whole, would have been obvious at the time the invention was made to a person having ordinary skill in the art to which said subject matter pertains. *KSR Int’l Co. v. Teleflex Inc.*, 550 U.S. 398, 406 (2007). The question of obviousness is resolved on the basis of underlying factual determinations including: (1) the scope and content of the prior art; (2) any differences between the claimed subject matter and the prior art; (3) the level of ordinary skill in the art; and (4) when in evidence, objective

---

<sup>1</sup> Petitioner supports its challenges with a Declaration of Dwight Crevelt (Ex. 1003). *See infra*.

<sup>2</sup> The Leahy-Smith America Invents Act (“AIA”), Pub. L. No. 112-29, 125 Stat. 284, 287–88 (2011 amended 35 U.S.C. §§ 102–103, effective March 16, 2013). Because the application from which the ’635 patent issued has an effective filing date prior to March 16, 2013, the pre-AIA version of § 103 applies. *See* Ex. 1001, code 63.

<sup>3</sup> Ex. 1008, US Patent No. 5,970,143 (Oct. 19, 1999).

<sup>4</sup> Ex. 1009, US Patent Publ’n No. 2003/0078102 A1 (Apr. 24, 2003).

evidence of nonobviousness.<sup>5</sup> *Graham v. John Deere Co.*, 383 U.S. 1, 17–18 (1966).

“In an [*inter partes* review], the petitioner has the burden from the onset to show with particularity why the patent it challenges is unpatentable.” *Harmonic Inc. v. Avid Tech., Inc.*, 815 F.3d 1889, 1363 (Fed. Cir. 2016) (citing 35 U.S.C. § 312(a)(3) (requiring *inter partes* review petitions to identify “with particularity . . . the evidence that supports the grounds for the challenge to each claim”)). This burden of persuasion never shifts to Patent Owner. *See Dynamic Drinkware, LLC v. Nat’l Graphics, Inc.*, 800 F.3d 1375, 1378 (Fed. Cir. 2015) (discussing the burden of proof in *inter partes* review).

We organize our patentability analysis into four sections. First, we address the level of ordinary skill in the art. Second, we address claim construction. Third, we provide an overview of the necessary asserted references. And fourth, taking account of the information presented by both parties, we consider and determine for the reasons explained below why the Petition satisfies the threshold requirement for instituting an *inter partes* review under 35 U.S.C. § 314(a).

#### *A. Level of Ordinary Skill in the Art*

Petitioner asserts that a person of ordinary skill in the art at the time of the ’635 patent

would have had at least a bachelor’s degree in computer science or computer engineering, with at least three years of experience in game development . . . [a]dditional experience could substitute

---

<sup>5</sup> Patent Owner does not present arguments or evidence of secondary considerations in its Preliminary Response. Therefore, secondary considerations do not constitute part of our analysis.

for less education, and additional education could likewise substitute for less experience.

Pet. 12 (citing Ex. 1003 ¶¶ 72–75).

Patent Owner states that “[w]hile Patent Owner disagrees with the proposed level of skill, under any level of skill a POSITA would not understand the asserted Grounds to raise any unpatentability issue.” Prelim. Resp. 5. Patent Owner does not, at this point, propose a different level of skill. *Id.*

On this record, Petitioner’s proposed level of ordinary skill in the art is not contradicted and is consistent with our review and understanding of the technology and descriptions in the ’635 patent and the asserted prior art references. *See Okajima v. Bourdeau*, 261 F.3d 1350, 1355 (Fed. Cir. 2001). For purposes of this Decision, we rely on Petitioner’s proposed level of ordinary skill in the art.

#### *B. Claim Construction*

At this early stage of the proceeding, no claim terms are disputed and neither party offers any particular construction for any claim term. Pet. 12–13; Prelim. Resp. 5. Having considered both parties arguments and evidence in light of the challenged claims, at this stage, we are not apprised of any reason to expressly construe any claim term for purposes of institution. *See Nidec Motor Corp. v. Zhongshan Broad Ocean Motor Co.*, 868 F.3d 1013, 1017 (Fed. Cir. 2017) (“[W]e need only construe terms ‘that are in controversy, and only to the extent necessary to resolve the controversy.’” (quoting *Vivid Techs., Inc. v. Am. Sci. & Eng’g, Inc.*, 200 F.3d 795, 803 (Fed. Cir. 1999))).

*C. The Prior Art*

Before turning to Petitioner’s initial ground of unpatentability, we provide a brief summary of the asserted references Schneier and Okita.

1. *Schneier*<sup>6</sup> (*Ex. 1008*)

Schneier describes broadly an authentication and auditing system for computer generated gaming and “also provides for ‘pay-per-use’ in the home video game environment, where any game computer may be turned into a video game arcade machine by metering usage of the game computer and/or game programs that run on the game computer.” *Ex. 1008* 1:13–44. Schneier discloses “computer generated game tournaments in which players play the games on game computers and compete against each other by submitting the outcomes for those tournament games to the central computer, which certifies the outcomes and rates and ranks the players.” *Id.* at 1:25–30.

Schneier teaches that “tournament play contains variables which are read by the game computers and direct the game programs to set game parameters based on player’s individual ratings or other parameters.” *Id.* at 5:56–60. Schneier discloses that “game programs generate games that are typically segregated into various levels, where the player advances from level to level as the game proceeds.” *Id.* at 24:43–45. Schneier further discloses “[i]n an arcade-type embodiment, the player purchases ‘credits’ to enable game play. This enables players to call the central computer 12 and obtain codes for a specified number of game plays, as in an arcade environment.” *Id.* at 62:50–53.

---

<sup>6</sup> In many instances both parties refer to Schneier as “Schneier143.”

In addition to “pay-to-play” scenarios, Schneier also discloses how game credits can be used to advance levels “to explore any of the first ten levels of a game, while any of the additional five bonus levels could be explored at a cost of one credit each.” *Id.* at 63:13–16. Schneier teaches using credits to purchase special items in the game to advance levels, for example “while exploring a ten-level dungeon, the player could be charged an additional credit for the use of a special weapon, access to a map of the dungeon, or hints on avoiding traps.” *Id.* at 63:16–19. Also, Schneier describes that credits “per dollar” can vary, for instance “[a] purchase of ten credits may cost \$0.50 each while a purchase of twenty credits may cost \$0.30 each.” *Id.* at 63:31–34. In one example, Schneier explains that “[c]redit discounts can be offered to select players who have obtained certain certified titles. A five-star MORTAL KOMBAT player may receive a 10% discount on all credits.” *Id.* at 63:34–37.

2. *Okita (Ex. 1009)*

Okita is titled “Video Game System, Video Game Apparatus and Video i.” Ex. 1009, code 54. Okita’s video game system includes “a player information storage unit 371 that stores player information including information regarding virtual money used in the game.” *Id.* at Abstract. Okita discloses a “virtual money conversion unit 161 $n$  that performs conversion between virtual money and prescribed pseudo-values.” *Id.* Okita explains that pseudo-values, which are earned points in a video game, “refer[] to the player’s performance results in the game, and these points or results have values during the game.” *Id.* ¶ 4. Okita also describes real money conversion unit 161 $m$  that performs conversion of coins into virtual money using a prescribed exchange rate.” *Id.*

Okita's Figure 4 is reproduced below.

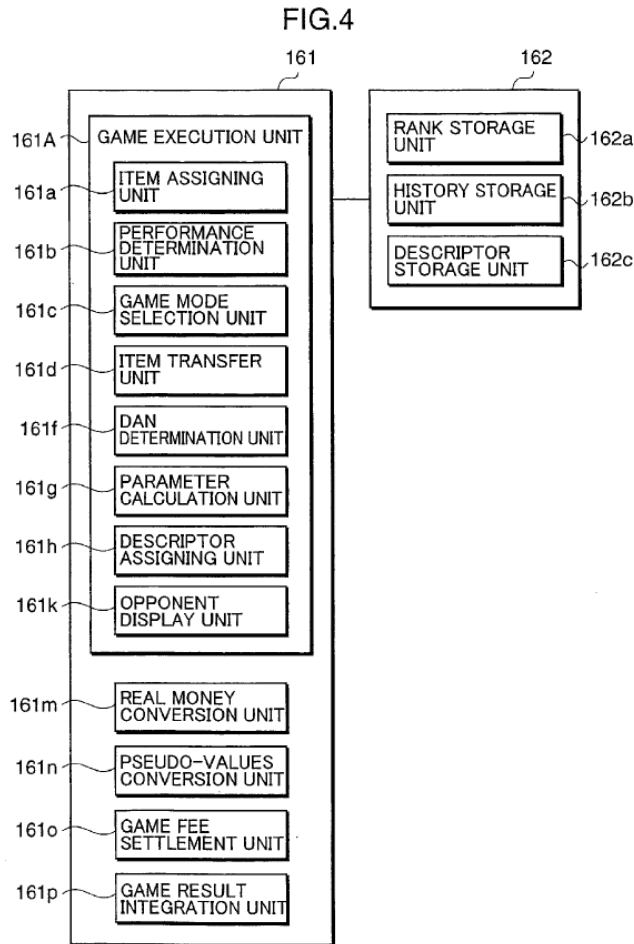

Figure 4 illustrates Okita's CPU 161 running game execution unit 161A based on, *inter alia*, operation instructions from the player, a real money conversion unit 161m and a pseudo-values conversion unit 161n. *Id.* ¶ 67.

Okita further explains that in one embodiment “[t]he real money conversion unit 161m performs conversion of the coins received via the coin receiving unit 15 and virtual money using a prescribed exchange rate. The prescribed exchange rate here is a rate used in order to perform conversion between virtual money and real money.” *Id.* ¶ 71. Similarly, “The pseudo-values conversion unit 161n performs conversion between the prescribed

pseudo-values . . . and virtual money, using a prescribed exchange rate.” *Id.*  
¶ 72.

*D. Ground 1: Claims 1, 2, 4, 6, 8–10, 14–18, 21–23, 25, 27, and 29 –  
Alleged Obviousness over Schneier*

We have reviewed Petitioner’s cited evidence, including the prior art and Mr. Crevelt’s declaration, and find that Petitioner has shown a reasonable likelihood of prevailing on its challenge to claim 1 based on Schneier. Pet. 13–27. In their Preliminary Response, Patent Owner has disputes Petitioner’s arguments regarding limitations [1.b.i-iv] and the claimed “virtual money.” Prelim. Resp. 6–11. We, therefore, address specifically the parties’ arguments with respect to these claim limitations.

*1. Petitioner’s Arguments as to Limitations [1.b.i-iv] and  
the Claimed “virtual money”*

*a) Limitation [1.b.i] - the game play information  
including game play with virtual money*

Petitioner asserts that Schneier discloses a home video game including a “pay-per-use” system where game play includes using “credits” which “are alternative currency with no real world counterpart and no consistently defined relationship with real currency.” Pet. 19 (citing Ex. 1008, 1:40–43, 6:50–53, 70:53). Petitioner argues that Schneier “uses the credits as alternative currency, that can be used in accordance with different pricing protocols.” *Id.* (citing Ex. 1008, 1:44–45).

*b) Limitation [1.b.ii] – the virtual money being  
acquired through:*

Referencing its arguments for subsequent limitations [1.b.ii.A–B] Petitioner argues that “the credits (*virtual money*) may be acquired by achieving certain levels of performance during the game (*being acquired*

*through . . . game play) or purchase (being acquired through cash purchase).”* *Id.* at 20 (citing Ex. 1008, 63:23–29).

*c) Limitation [1.b.ii.A] - game play and*

Petitioner argues that Schneier includes “[i]n one example game, ‘scoring over a million points in DONKEY KONG might result in an extra credit being added to the available credit balance.’” *Id.* (quoting Ex. 1008, 63:25–27).

*d) Limitation [1.b.ii.B] – cash purchase*

Petitioner argues that Schneier “discloses that ‘[i]n an arcade-type embodiment, the player purchases ‘credits’ to enable game play.’” *Id.* (quoting Ex. 1008, 62:50–51).

*e) Limitation [1.b.iii] – the virtual money acquired by cash purchase being subject to a multiplier*

Petitioner contends that Schneier’s credit, depending on the circumstances, can be subject to a multiplier where, “[f]or example, ‘[a] purchase of ten credits may cost \$0.50 each while a purchase of twenty credits may cost \$0.30 each.’” *Id.* at 21 (quoting Ex. 1008, 63:31–34). Petitioner argues that a person of ordinary skill in the art “would have understood that in these two examples, one dollar equals 20 credits and three dollars equals 200 credits, respectively.” *Id.* (quoting Ex. 1003 ¶ 100).

*f) Limitation [1.b.iv] – conversion of the virtual money into a non-cash good comprising an image to permit advancement to another level within the game,*

Petitioner argues that Schneier “discloses ‘[e]xtra credits can be required to complete restricted stages of a game’ or ‘the player could be charged an additional credit for the use of a special weapon, access to a map of the dungeon, or hints on avoiding traps.’” *Id.* at 22–23 (quoting Ex. 1008,

63:12–19). According to Petitioner, Schneier “also discloses how ‘[e]ach credit might also buy a certain number of lives.’” *Id.* at 23 (quoting Ex. 1008, 63:37–38). Based on Mr. Crevelt’s testimony, Petitioner asserts that a person of ordinary skill in the art “would have understood that the purchase of a non-cash good such as access to restricted portions of the game, game items, or lives, would include an image.” *Id.* (citing Ex. 1003 ¶ 107).

2. *Patent Owner’s Arguments as to Limitations [1.b.i-iv] and the Claimed “virtual money”*

Patent Owner argues mainly that Petitioner fails to show that Schneier discloses “game play with virtual money,” as recited in limitations 1[b.i-iv]. Prelim. Resp. 6. Patent Owner makes two specific arguments. First, it argues that Petitioner fails to show that Schneier’s “‘credits,’ used to ‘pay-per-*use*’ of a game, are ‘virtual money’ as required by the claims.” *Id.* Second, and relatedly, Patent Owner argues that there is no disclosure in Schneier for conversion of credits to “non-cash goods comprising an image” as required in limitation [1.b.iv]. *Id.* at 7.

a) *Whether Schneier’s “credits” are “virtual money”*

Patent Owner argues that in Schneier “‘credits’ are not a medium of exchange,” and “Petitioners point to no disclosure in Schneier that its ‘credits’ can be used in ‘trad[e] for cash or other forms of games, prizes or non-cash goods or services,’ or ‘exchanged for other valuable forms of goods or services,’ as described by the ’635 patent.” *Id.* at 6 (quoting Ex. 1001, 46:16–23).

We disagree. As an initial matter, the ’635 patent expressly describes that the claimed “virtual money”, i.e., “vCoins may be acquired by purchase, or may be awarded in a non-cash purchase manner *such as provided for a credit.*” Ex. 1001, 46:7–9 (emphasis added). Moreover, as Petitioner points

out, Schneier explicitly describes that a player can trade credits for goods and services. Pet. 22–23. For example, Schneier explains that the player “could be charged an additional credit for the use of a special weapon, access to a map of the dungeon, or hints on avoiding traps.” Ex. 1001, 63:17–19.

On the evidence before us at this point in the proceeding, we find that Petitioner has sufficiently shown for purposes of institution that a person of ordinary skill in the art would have understood Schneier’s credits to be virtual money and vCoins as recited in the challenged claims.<sup>7</sup>

*b) Whether Schneier discloses conversion of credits to “non-cash goods comprising an image”*

Considering, as discussed above, that credits can be used to accrue a special weapon or map, Petitioner has sufficiently shown for purposes of institution that Schneier discloses this use of “virtual money.” *Id.* Patent Owner identifies no persuasive evidence on the current record to refute that a purchased map and a weapon are non-cash goods that facilitate game play and completing or advancing from one level of a game to the next. *See* Ex. 1003 ¶ 61 (Mr. Crevelt testifying that “[i]t was known in the art to have multi-level games, and to use virtual special items for advancement to another level within the game.”). Further, the evidence on the current record supports Petitioner’s contention that a person of ordinary skill in the art would also have understood that game play items such as a weapon or map would have been displayed to the player as an image. *See id.* ¶ 107 (“Mr. Crevelt testifying that a person of ordinary skill in the art would have understood that “[e]ach purchase would need to be reflected in the display of

---

<sup>7</sup> Claim 3 recites “wherein the virtual money comprises vCoins.” Ex. 1001, 47:20–21.

the game through an image, so that the user could use that purchase to advance to another level.”).

On this record, we find that Petitioner has sufficiently shown for purposes of institution that Schneier discloses “virtual money” and “conversion of virtual money into a non-cash good comprising an image” as recited in claim 1.

3. *Dependent Claims 2, 4, 6, 8–10, 14–18, 21–23, 25, 27, and 29*

Patent Owner does not raise any substantive arguments regarding the remaining dependent claims, instead asserting mainly that “Petitioners have failed to demonstrate a reasonable likelihood that Claim 1, or any dependent claim, is unpatentable.” Prelim. Resp. 7. We have reviewed Petitioner’s evidence and arguments as to these dependent claims and, at this stage, we find them sufficient for institution. Pet. 27–45. On the current record, Petitioner has shown a reasonable likelihood that claims 1, 2, 4, 6, 8–10, 14–18, 21–23, 25, 27, and 29 would have been obvious over Schneier.

*E. Ground 2: Claims 1, 2, 4, 6, 8–10, 14–18, 21–23, 25, 27, and 29 – Alleged Obviousness over Schneier and Okita*

Petitioner argues that “[t]o the extent that *virtual money* is construed to exclude credits, Schneier[] in view of Okita renders obvious this limitation.” Pet. 46. Petitioner argues that a person of ordinary skill in the art would have combined Schneier and Okita because Okita’s “virtual money conversion functionality enhances the user experience by creating “feelings of realism and tension when the game is played.” *Id.* (citing Ex. 1009 ¶ 6. Also, Petitioner’s declarant, Mr. Crevelt, testifies that a person of ordinary skill in the art “would have understood that virtual money that could be used across multiple game spaces, and not limited to a single game

space, would have encouraged players to engage in more game play.” Ex. 1003 ¶ 140.

Patent Owner argues that Okita does not remedy the alleged failure of Schneier to disclose, “conversion of the virtual money into a non-cash good comprising an image to permit advancement to another level within the game” as recited in limitation [1.b.iv]. Prelim. Resp. 8–9. Patent Owner argues specifically that “Petitioners point to no disclosure in Okita of any image that permits advancement to another level within the game, or any mechanism that would convert virtual money into a non-cash good comprising such an image.” *Id.* at 9. Patent Owner also argues that Petitioner has failed to show a motivation to combine Schneier and Okita. *Id.* at 9–11.

Considering first the motivation to combine, we find Petitioner’s reasoning sufficiently persuasive for purposes of institution. Petitioner argues that Okita’s “pseudo values” are just like Schneier’s credits and “[b]ecause the pseudo-values can be exchanged for virtual money that can be used in other tournaments, arcades, or the like, ‘a game can be provided that generates tension for the player due to the fact that the virtual money is earned or is confiscated based on the game results.’” Pet. 47 (quoting Ex. 1009 ¶ 9). Petitioner’s declarant, Mr. Crevelt, further testifies that Okita’s “[r]ewards programs are a routine feature of games because players are encouraged to play more to accumulate points or other pseudo-values to exchange for prizes or other items . . . [t]he virtual money conversion functionality would have opened up more game play options and more items to purchase.” Ex. 1003 ¶ 140.

Based on the record before us, Petitioner has shown sufficiently for purposes of institution that the use of Okita’s pseudo-values and broad

applicability of these values within a reward system would have raised a player's interest and engagement with the video game.

As for whether Okita teaches limitation [1.b.iv], Okita discloses that with “pseudo-values (earned points) earned via a game protagonist, the player can buy supplies, items or the like during the game.” Ex. 1009 ¶ 5. We also have currently unrebutted testimony from Mr. Crevelt that a person of ordinary skill in the art “would have understood that the purchase of a non-cash good such as access to restricted portions of the game, game items, or lives, would include an image.” Ex. 1003 ¶ 156.

Patent Owner does not raise any substantive arguments regarding the challenged dependent claims besides the arguments considered above with respect to claim 1. Prelim. Resp. 9.

We have reviewed Petitioner's evidence and arguments to all the challenged claims and, at this stage, we find them sufficient for institution. Pet. 27–54. Accordingly, on the current record, Petitioner has shown a reasonable likelihood that claims 1, 2, 4, 6, 8–10, 14–18, 21–23, 25, 27, and 29 would have been obvious over Schneier and Okita.

#### IV. CONCLUSION

For the foregoing reasons, the information presented in the Petition and accompanying evidence establishes a reasonable likelihood that Petitioner would prevail in showing the unpatentability of at least one of the challenged claims.

#### V. ORDER

In consideration of the foregoing, it is hereby:

ORDERED that the Petition is *granted*; and

FURTHER ORDERED that *inter partes* review is instituted.

IPR2025-00709  
Patent 10,650,635 B2

For PETITIONER:

Lisa K. Nguyen  
Naveen Modi  
PAUL HASTINGS LLP  
lisanguyen@paulhastings.com  
naveenmodi@paulhastings.com

For PATENT OWNER:

John Pierce  
TENSEGRITY LAW GROUP LLP  
john.pierce@tensegritylawgroup.com