

Certification of Accuracy

I, Qiang Li, hereby attest that I am a translator fluent in Chinese and English, that I have translated the attached document from Chinese to English, and that to the best of my knowledge, ability and belief this translation is a true, accurate and complete translation of the original Chinese document that was provided to me.

The document is designated as:

CN201832737U
CN202566813U

Signature of Translator

10/12/2024

Date

(19) The National Intellectual Property Administration of the People's Republic of China



(12) Utility Model Patent



(10) Patent No.: CN 201832737 U

(45) Patent Date: May 18, 2011

(21) Appl. No.: 201020281932.5

(22) Filed on: August 4, 2010

(73) Patent Holder: GAO Xiaoyang

Address: No. 30, Wenfeng East Avenue, Wenfeng Town, Jishui County, Ji'an City,
Jiangxi 331600

(72) Inventor(s): GAO Xiaoyang

(51) Int. Cl.

B05B 7/0 (2006. 01)

B05B 3/02 (2006. 01)

A61L 9/14 (2006. 01)

Claims 1 page, Description 3 pages, Drawings 2 pages

(54) Title of Utility model

Atomizer for atomizing essence or essential oil

(57) Abstract of Disclosures

The present utility model discloses an atomizer for atomizing essence or essential oil, comprising an atomizer body, a first cavity and a second cavity are provided in the atomizer body, an atomizing gas outlet is provided on a top wall of the first cavity, a reflux hole is further provided on a bottom wall of the first cavity, a baffle is provided on an upper part of the first cavity to form a top part cavity and a lower part cavity, a through hole is provided between the top part cavity and the lower part cavity, an gas flow spray hole is provided on a side wall of the lower part cavity, the lower part cavity is in communication with a bottom part of the second cavity through the gas flow spray hole, a gas flow nozzle is fixed in the second cavity, a gap is

arranged between the gas flow nozzle and a bottom wall of the second cavity, an atomizing cavity is formed between the gas flow nozzle and the bottom wall of the second cavity, a liquid pipe is further provided on the atomizer body, and the liquid pipeline is in communication with the atomizing cavity. The present utility model is a cold atomization type device, does not require heating, and can effectively maintain the natural aroma of essence and essential oil; in addition, the atomized particles are finer and more uniform, the aroma is more uniform, and the aroma diffusion area is large.

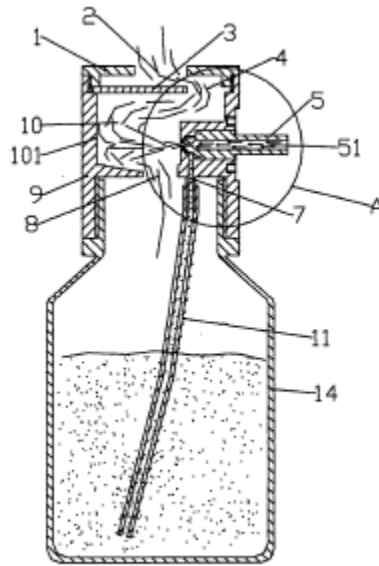

CN 201832737 U

1. An atomizer for atomizing essence or essential oil, comprising an atomizer body, characterized in that: the atomizer body is provided with a first cavity and a second cavity, a top wall of the first cavity is provided with an atomizing gas outlet, a bottom wall of the first cavity is further provided with a reflux hole, an upper part of the first cavity is provided with a baffle, a gap is provided between the baffle and the top wall, a top part cavity is formed between the baffle and the top wall, a lower part cavity is formed between the baffle and the bottom wall of the first cavity, a through hole is provided between the top part cavity and the lower part cavity, a gas flow spray hole is provided on a side wall of the lower part cavity, the lower part cavity is in communication with a bottom part of the second cavity through the gas flow spray hole, a gas flow nozzle is fixed in the second cavity, a gap is provided between the gas flow nozzle and a bottom wall of the second cavity, an atomizing cavity is formed between the gas flow nozzle and the bottom wall of the second cavity, a liquid pipeline is further provided on the atomizer body, and the liquid pipeline is in communication with the atomizing cavity.

2. The atomizer for atomizing essence or essential oil according to claim 1, characterized in that: the atomizer body is composed of a main body and a cover body, the main body is a rotating body made of an aluminum material, an upper cavity and a lower cavity are provided on the main body, a communication hole is provided between the upper cavity and the lower cavity, an internal thread is provided on an inner wall of the lower cavity, the baffle is fixed to an upper part of the upper cavity by means of the cover body, a side of the baffle is spaced from a side of the upper cavity, a rotating cavity is further provided on the main body, an axis of the rotating cavity is perpendicular to an axis of the upper cavity, a pipe is provided on the main body close to a bottom part of the rotating cavity, a pipe port is connected to a hose, the gas flow nozzle is a rotating body made of a copper material, a coaxial gas flow pipe is provided in the gas flow nozzle, and a step is provided on an outer wall of a top part of the gas flow nozzle.

ATOMIZER FOR ATOMIZING ESSENCE OR ESSENTIAL OIL

Technical Field

[0001] The present utility model relates to the technical field of atomizers, in particular to an atomizer used for atomizing essence or essential oil.

Background Art

[0002] At present, people pay more and more attention to the environment of public places such as hotels, shopping malls, and airports. Especially in the hot summer, people especially want a fresh and natural air, and hope that the cool aroma can bring a refreshing feeling to the hot summer. For this reason, people often take the following measures in these places: 1. Using mainly a heating method, in which a heating rod is used to gasify essence and essential oil; 2. using the air two-fluid atomization technology; 3. using a small essential oil atomizer, such as that disclosed in the Chinese patent application number 200510132555.2.

[0003] These existing technologies accordingly have the following disadvantages:

[0004] 1. In the case of using electric heating, the essences and essential oils may have a certain difference from the original smell during the heating process. In addition, some essences and essential oils can generate harmful gases after being heated to a certain temperature. Thus, this cannot meet the requirements of the places with high safety and aroma requirements. The particles produced by the heating method are large and not uniform, and they are very easy to adhere to the air conditioning pipes and other objects. As a result, the air conditioning filter may be blocked after a long time period of use.

[0005] 2. In the case of the air two-fluid atomization, the atomization particles have a large range in size, are generally between 1-50 microns, and are not uniform. The large particles can easily adhere to the air conditioning pipes and other objects, and may also block the air conditioning filter after a long time period of use.

[0006] 3. Regarding the Chinese patent application number 200510132555.2, this device has a complex structure and can generally only provide aroma in an area of 50 square meters. Therefore, the aroma diffusion area of this device is limited.

Summary of the Utility model

[0007] An object of the present utility model is to provide an atomizer for atomizing essence or essential oil, the atomizer adopts a cold atomization mode, does not require heating, can effectively maintain the natural aroma of essence and essential oil; in addition, the atomized particles are finer and more uniform, the aroma is more uniform, and the aroma diffusion area is large.

[0008] The object of the present utility model is achieved through the following technical solutions.

[0009] An atomizer for atomizing essence or essential oil, comprising an atomizer body, characterized in that: the atomizer body is provided with a first cavity and a second cavity, a top wall of the first cavity is provided with an atomizing gas outlet, a bottom wall of the first cavity is further provided with a reflux hole, an upper part of the first cavity is provided with a baffle, a gap is provided between the baffle and the top wall, a top part cavity is formed between the baffle and the top wall, a lower part cavity is formed between the baffle and the bottom wall of the first cavity, a through hole is provided between the top part cavity and the lower part cavity, a gas flow spray hole is provided on a side wall of the lower part cavity, the lower part cavity is in communication with a bottom part of the second cavity through the gas flow spray hole, a gas flow nozzle is fixed in the second cavity, a gap is provided between the gas flow nozzle and a bottom wall of the second cavity, an atomizing cavity is formed between the gas flow nozzle and the bottom wall of the second cavity, a liquid pipeline is further provided on the atomizer body, and the liquid pipeline is in communication with the atomizing cavity.

[0010] The atomizer body is composed of a main body and a cover body, the main body is a rotating body made of an aluminum material, an upper cavity and a lower cavity are provided on the main body, a communication hole is provided between the upper cavity and the lower cavity, an internal thread is provided on an inner wall of the lower cavity, the baffle is fixed to an upper part of the upper cavity by means of the cover body, a side of the baffle is spaced from a side of the upper cavity, a rotating cavity is further provided on the main body, an axis of the rotating cavity is perpendicular to an axis of the upper cavity, a pipe is provided on the main body close to a bottom part of the rotating cavity, a pipe port is connected to a hose, the gas flow nozzle is a rotating body made of a copper material, a coaxial gas flow pipe is provided in the gas flow nozzle, and a step is provided on an outer wall of a top part of the gas flow nozzle.

[0011] Compared with the existing technology, the present utility model has the following advantages:

[0012] 1. It adopts a cold atomization method, does not require heating, and can maintain the natural aroma of essences and essential oils.

[0013] 2. The particles are finer and more uniform, and are easier to vaporize after contact with the air, and the aroma is more uniform.

[0014] 3. The atomizer core is made of copper, and other parts are made of aluminum. This way, the air pressure can be higher, the liquid atomization effect is better, and the atomization volume is larger.

[0015] In summary, the product set forth in the present utility model can atomize high-viscosity liquids such as essences and essential oils into particles below micrometers. The finer the atomized particles, the more uniform the smell. When the atomized particles are ultra-fine mist, they will not adhere to the pipes and filters.

Brief Description of the Drawings

[0016] FIG. 1 is a schematic diagram of the structure of an atomizer for atomizing essence or essential oil according to the present utility model.

[0017] FIG. 2 is an enlarged schematic diagram of point A in FIG. 1.

Description of the Embodiments

[0018] The atomizer for atomizing essence or essential oil of the present utility model will be further described in detail below in conjunction with the accompanying drawings.

[0019] As shown in FIG. 1-2, the present utility model provides an atomizer for atomizing essence or essential oil, which comprises an atomizer body. The atomizer body is provided with a first cavity and a second cavity 13. A top wall of the first cavity is provided with an atomizing gas outlet 2. A bottom wall of the first cavity is further provided with a reflux hole 8. An upper part of the first cavity is provided with a baffle 3. A gap is provided between the baffle and the top wall. The baffle and the top wall form a top part cavity. The baffle and the bottom wall of the first cavity form a lower part cavity 10. A through hole 4 is provided between the top part cavity and the lower part cavity 10. A gas flow spray hole 12 is provided on a side wall of the lower part cavity 10. The lower part cavity 10 is in communication with a bottom part

of the second cavity 13 through the gas flow spray hole 12. A gas flow nozzle 5 is fixed in the second cavity 13. A gap is provided between the gas flow nozzle 5 and the bottom wall of the second cavity 13. An atomizing cavity 6 is formed between the gas flow nozzle 5 and the bottom wall of the second cavity. A liquid pipeline 7 is further provided on the atomizer body, and the liquid pipeline 7 is in communication with the atomizing cavity 6.

[0020] The atomizer body is composed of a main body 9 and a cover body 1. The main body 9 is a rotating body made of an aluminum material. The main body 9 is provided with an upper cavity and a lower cavity. A communication hole is provided between the upper cavity and the lower cavity, which is the reflux hole 8 on the bottom wall of the first cavity. An inner wall of the lower cavity is provided with an internal thread for fixing the entire atomizer on an essence or essential oil bottle 14. The cover body 1 is provided with the aforementioned atomizing gas outlet 2.

[0021] The baffle 3 is fixed to an upper part of the upper cavity by means of the cover body 1. A side of the baffle 3 is spaced from a side of the upper cavity, thereby forming an outlet for the rising gas flow, which is the through hole 4 provided between the top part cavity and the lower part cavity.

[0022] A rotating cavity is further provided for the main body 9, which is the second cavity 13 mentioned above. An axis of the rotating cavity is perpendicular to an axis of the upper cavity. A pipe is provided for the main body close to a bottom part of the rotating cavity, and the pipe port is connected to a hose 11.

[0023] The gas flow nozzle 5 is a rotating body made of a copper material. A coaxial gas flow pipe 51 is provided inside the gas flow nozzle 5. A step is provided on an outer wall surface of a top part of the gas flow nozzle. The specific number of the step can be determined according to the needs, so as to achieve the formation of the atomizing cavity 6 and the sealing of the corresponding connections.

[0024] The atomizer is installed on a central aroma apparatus and an aroma spreading system.

[0025] The atomization process of the atomizer is as follows: the gas inlet on a side of the atomizer, i.e., the inlet of the gas flow pipe 51, is connected to the air pump. When the air pump is in operation, a gas flow is blown out through the pipe. The liquid is sucked into the atomizing cavity 6 based on the siphon principle, and the liquid and the gas are fully mixed. The

high-speed gas-liquid mixture is then ejected through a gas flow flow port and hits an inner wall 101 of the lower part cavity 10, thus the liquid is atomized into micron-sized fine particles. The smallest particles will float in the air, and drift out through the through hole 4 and the atomizing gas outlet 2 with the rising gas flow to be converted into gas through heat exchange with the air. The smaller the particles, the easier it is to convert into gas. Other larger particles are recovered in the lower part cavity 10 and refluxed into the bottle as essence and essential oil through the reflux hole 8. Since most of the essence and essential oil are oily substances with high viscosity, if the atomized particles are too large, the particles will adhere to other objects. However, by using the structure of the present utility model, the mist can be controlled below 3 microns, so that the liquid atomization effect is better and the atomization amount is larger.

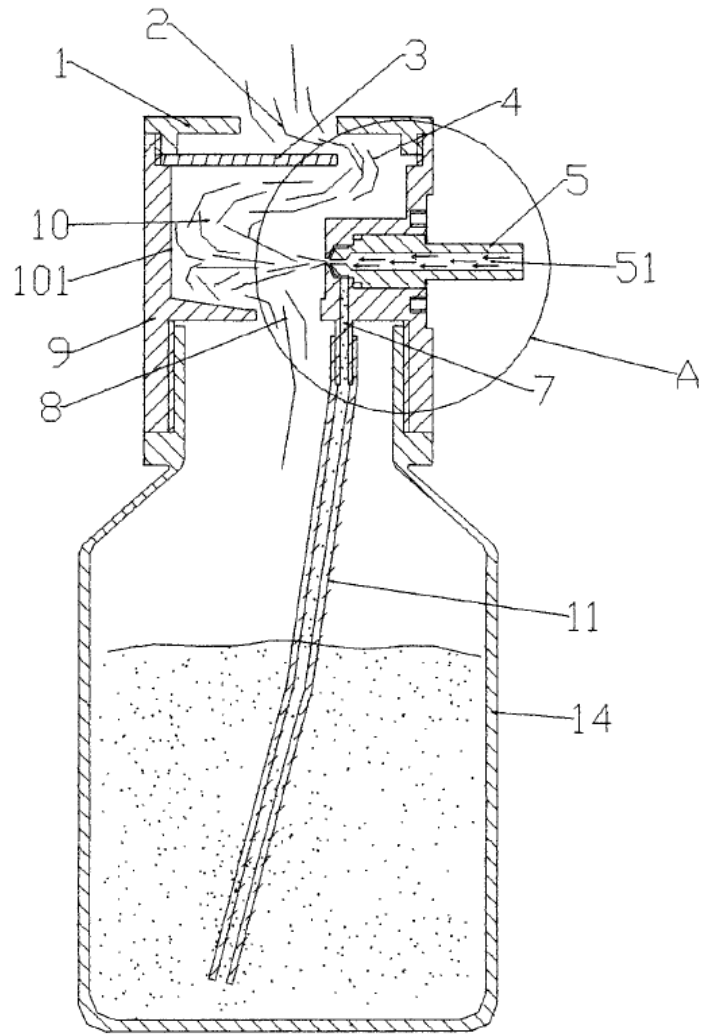

FIG. 1

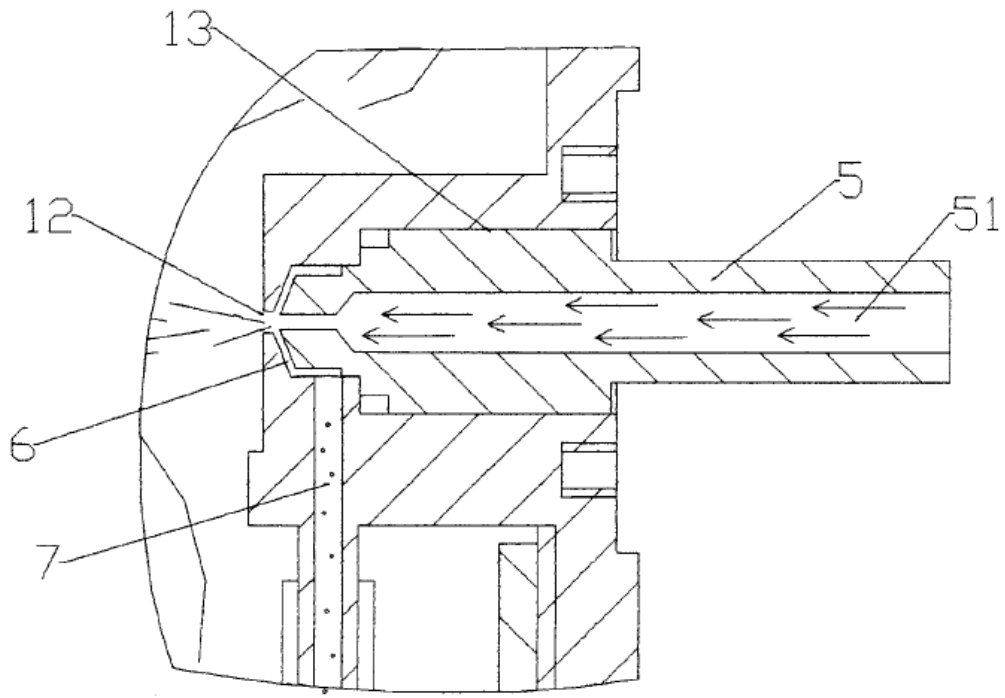

FIG. 2