

EXHIBIT D-27

Invalidity of U.S. Patent No. 9,641,204 by U.S. Patent No. 6,999,523 to Posti (“Posti”)

The Asserted Claims of U.S. Patent No. 9,641,204 (“the ’204 Patent”) are anticipated and/or rendered obvious in view of U.S. Patent No. 6,999,523 (“Posti”) alone or in combination with other prior art. Posti was filed on June 22, 2001 and was published on February 21, 2002, claiming priority as a continuation of International Patent Application No. PCT/EP98/08445, filed December 24, 1998. Posti, thus, is prior art to the ’204 Patent at least under 35 U.S.C. § 102(b).

As described in detail below, Posti anticipates Asserted Claims 1–15 of the ’204 Patent. In addition, to the extent that Smart RF asserts that Posti or citations below are insufficient, every limitation set forth in the claim was predictable and obvious in view of the knowledge and progression of the art. As such, it would have been obvious to one of ordinary skill in the art at the time of the alleged invention, based on the explicit and implicit teaching of this reference and the prior art, the knowledge of one of ordinary skill in the art, and/or the nature of the claimed invention and the problem(s) purportedly being solved to take the purportedly missing element from the art and combine it with the other elements in prior art identified in the cover pleading or herein.

This claim chart is based on Defendants’ present understanding of the asserted claims, Smart RF’s vague and overbroad infringement contentions (and corresponding, implicit claim constructions), and Defendants’ investigations to date. Defendants are not adopting Smart RF’s apparent constructions, nor are Defendants admitting to the accuracy of any particular construction. Defendants reserve all rights to amend this invalidity claim chart in light of any claim-construction developments or any amendment to Smart RF’s infringement contentions. Further, as discovery is ongoing and Defendants continue to seek discovery from third parties regarding the references identified in Defendants’ invalidity contentions as well as other potential prior art, Defendants reserve the right to amend or supplement this claim chart identified in connection with Defendants’ continuing investigation. At minimum, Defendants intend to revise their invalidity contentions as appropriate to include discovery from third parties as discovery progresses. The claim chart below identifies where each limitation of the asserted claims of the ’204 Patent can be found in Posti. The citations provided below are exemplary, rather than exhaustive, and Defendants reserve the right to rely upon any other portion of the cited references.

Claim No.	’204 Patent	Exemplary Evidence of Anticipation and/or Obviousness
1[pre]	A transmitter comprising:	To the extent the preamble is limiting, Posti discloses and/or renders obvious a transmitter. <i>See, e.g.,</i> “A multi frequency carrier transmitter comprises input means for receiving a plurality of different digital signals to be transmitted. The different signals are to be transmitted on different carrier frequencies. Amplifier means receive a composite signal comprising the different signals at the

Claim No.	'204 Patent	Exemplary Evidence of Anticipation and/or Obviousness
		<p>respective carrier frequencies and amplify the composite signal. Predistortion means predistort the plurality of digital signals prior to amplification of the composite signal by the amplification means. The predistortion provided by the predistortion means is subsequently altered in dependence on the difference between the input signals and the output at the amplifier means.” Abstract.</p> <p>“The present invention relates to a transmitter and a method of transmitting and in particular, but not exclusively, for use in a telecommunications network.”</p> <p style="text-align: center;">Fig.4.</p> <p style="text-align: center;">Fig. 4.</p>

Claim No.	'204 Patent	Exemplary Evidence of Anticipation and/or Obviousness
		<p style="text-align: center;">Fig.5.</p> <p style="text-align: center;">Fig. 5.</p>

Claim No.	'204 Patent	Exemplary Evidence of Anticipation and/or Obviousness
-----------	-------------	---

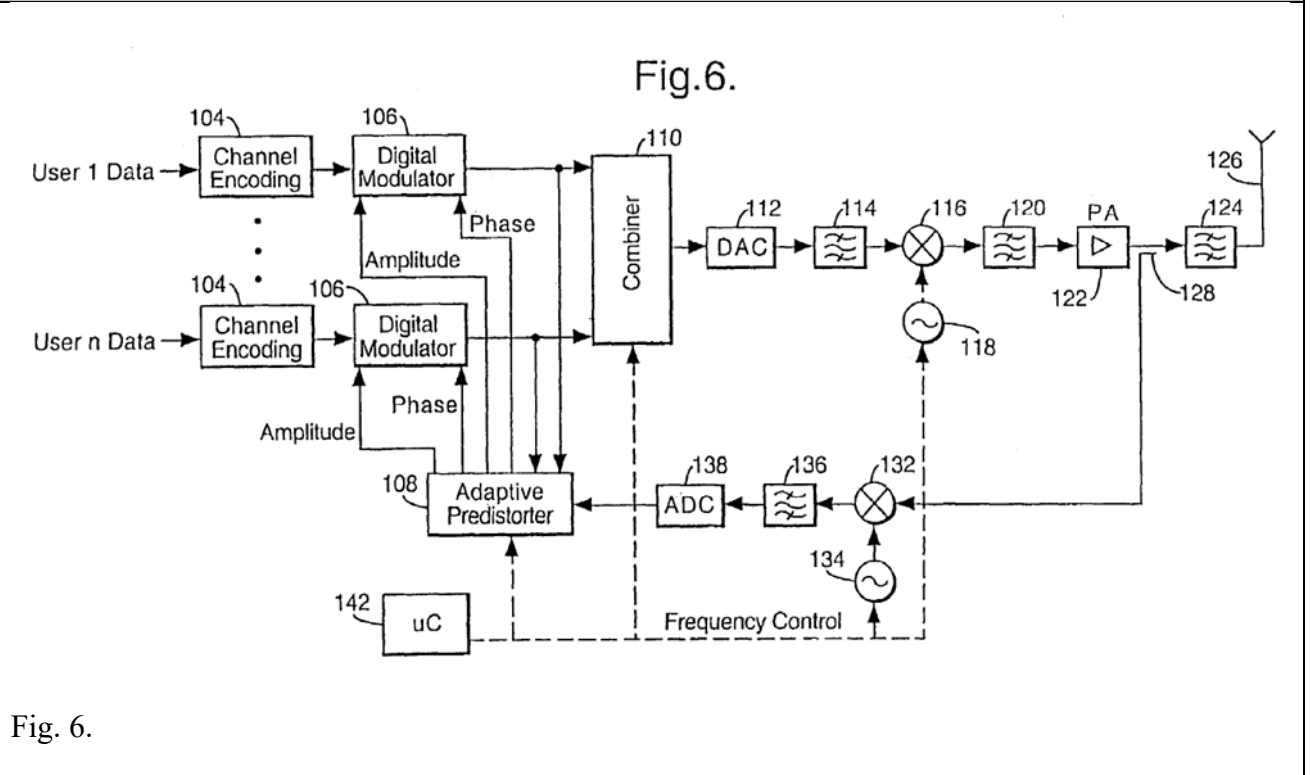

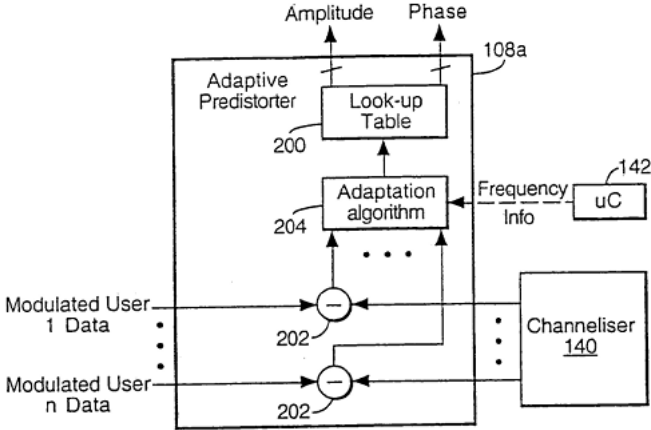
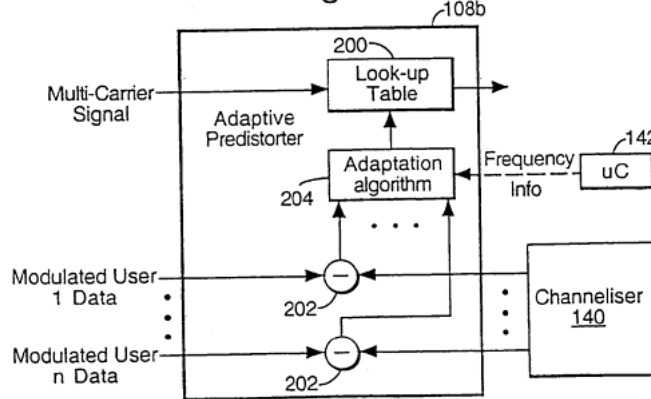
Claim No.	'204 Patent	Exemplary Evidence of Anticipation and/or Obviousness
		<p data-bbox="1144 188 1245 225">Fig.7.</p>  <p data-bbox="1144 788 1245 825">Fig.8.</p>  <p data-bbox="837 1286 1014 1323">Figs. 7 and 8.</p>

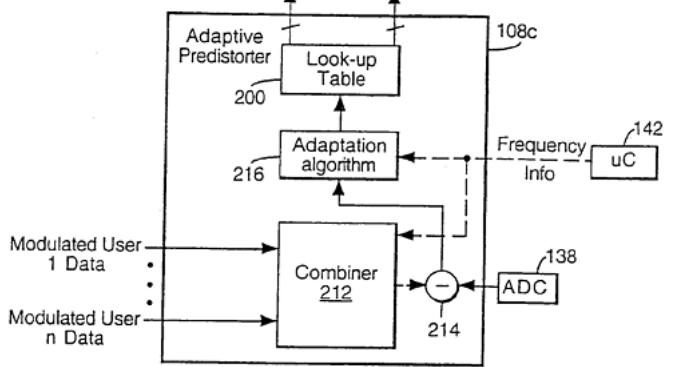
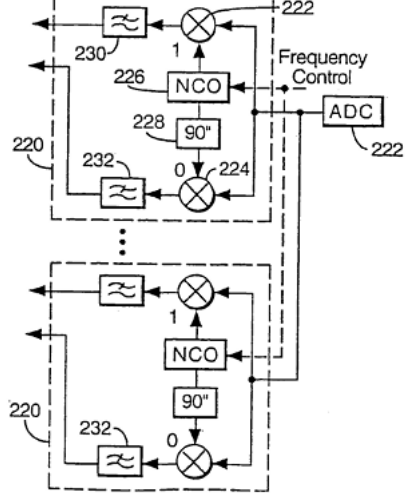
Claim No.	'204 Patent	Exemplary Evidence of Anticipation and/or Obviousness
		<p data-bbox="996 183 1276 223">Fig.9. Amplitude Phase</p>  <p data-bbox="974 678 1120 718">Fig.10.</p> <p data-bbox="974 718 1344 750">Principle of an NCO-Based Channeliser</p>  <p data-bbox="840 1284 985 1324">Figs. 9-10.</p>

Claim No.	'204 Patent	Exemplary Evidence of Anticipation and/or Obviousness
1[a]	a power amplifier configured to amplify modulated concurrent multi-band signals to provide amplified concurrent multi-band signals;	<p>Posti discloses and/or renders obvious a power amplifier configured to amplify modulated concurrent multi-band signals to provide amplified concurrent multi-band signals.</p> <p><i>See, e.g.,</i></p> <p>“A multi frequency carrier transmitter comprises input means for receiving a plurality of different digital signals to be transmitted. The different signals are to be transmitted on different carrier frequencies. Amplifier means receive a composite signal comprising the different signals at the respective carrier frequencies and amplify the composite signal. Predistortion means predistort the plurality of digital signals prior to amplification of the composite signal by the amplification means. The predistortion provided by the predistortion means is subsequently altered in dependence on the difference between the input signals and the output at the amplifier means.” Abstract.</p> <p>“The present invention relates to a transmitter and a method of transmitting and in particular, but not exclusively, for use in a telecommunications network.”</p> <p>“The output of each transmit path 14–14' is connected to the input of a combiner 22 which combines the signals from each path 14–14' to provide a multicarrier signal. The output of the combiner 22 is connected to an antenna 24 which transmits the multicarrier signal containing each of the N different channels to the terminals in the cell served by the base station.” 1:53-59.</p> <p>“According to one aspect of the present invention, there is provided a multi frequency carrier transmitter comprising input means for receiving a plurality of different digital signals to be transmitted, said different signals to be transmitted on different carrier frequencies; amplifier means for receiving a composite signal comprising said different signals at the respective carrier frequencies and amplifying said composite signal; and predistortion means for predistorting said plurality of digital signals prior to amplification of the composite signal by said amplification means, said predistortion provided by said predistortion means being subsequently altered in</p>

Claim No.	'204 Patent	Exemplary Evidence of Anticipation and/or Obviousness
		<p>dependence on the difference between said input signals and the output at said amplifier means.” 2:43-55.</p> <p>“Accordingly, embodiments of the present invention provide a multi carrier transmitter which is able to deal with the problems of nonlinearity by using predistortion. The predistortion can be implemented more simply than the feedback method discussed in the prior art.” 2:55-60.</p> <p>“The output of the second bandpass filter 120 is input to the power amplifier 122 which amplifies the received input. The output of the amplifier 122 is input to a third bandpass filter 124 which is arranged to filter out any signal components introduced by the amplifier 122 which fall outside the radio frequency band of the signals to be transmitted. The output of the third bandpass filter 124 is passed to an antenna 126 which transmits the signals to the terminals in the cell associated with the base station.” 5:41-49.</p> <p>“The input means are preferably arranged to separately receive each of the different signals. Combiner means are preferably provided between the input means and the amplifier means for combining said plurality of different signals to provide a composite signal. This may be the composite signal input to the amplifier means or may be a composite signal at a lower, intermediate frequency. In the latter case, that composite signal at a lower frequency would be upconverted to provide the composite signal input to the amplifier means.” 2:61-3:3.</p> <p>“A feedback path may be arranged between the amplifying means and the predistorting means. Preferably, the predistorting means is arranged to compare the output from the amplifying means from the feedback path with the signals received by the receiving means and to provide, if necessary, at least one new predistortion value to be applied to at least one subsequent signal received by the receiving means. In this way, the predistorting means can adapt to changes in the operating conditions of the amplifier means.” 3:14-21.</p> <p>“Preferably, means are provided in the feedback path for separating the output of the amplifying means into a plurality of different signals. The predistorting means is preferably arranged to compare each of the separated signals with the corresponding signals received from the input means and to determine if the at least one predistortion value needs to be altered.” 3:23-29.</p>

Claim No.	'204 Patent	Exemplary Evidence of Anticipation and/or Obviousness
		<p>“Alternatively, the predistorting means is arranged to compare the composite signal from the amplifying means with a plurality of different signals to provide, if necessary, the at least one new predistortion value.” 3:30-33.</p> <p>“The amplifier means is preferably a nonlinear amplifier. The predistortion means is preferably arranged to compensate for the nonlinearity of the phase and/or amplitude of the output of the amplifier.” 3:45-58.</p> <p>“A digital to analogue converter may be provided for converting the plurality of signals to analogue form before said signals are amplified by said amplifier means.</p> <p>The transmitter is preferably incorporated in a base station or alternatively in a mobile station.</p> <p>According to a second aspect of the present invention, there is provided a multi carrier frequency transmission method comprising the steps of receiving a plurality of different digital signals to be transmitted, said different signals to be transmitted on different carrier frequencies; combining said plurality of different signals to provide a composite signal comprising the different signals at the respective carrier frequencies; and amplifying said composite signal, wherein the method further comprises the steps of: predistorting the plurality of different digital signals prior to amplification of the composite signal by the amplification means; and altering the predistortion applied to subsequent signals in dependence on the difference between said different signals and the amplified signal.” 3:49-67.</p> <p>“Reference will now be made to FIG. 4 which shows a first embodiment of the present invention. In particular, the transmit part 102 of the base station 100 is shown. The base station 100 is in a cellular system of the type shown in FIG. 1.” 4:30-34.</p> <p>“The transmit part 102 of the base station 100 comprises N channel encoders 104 where N is the number of different frequencies on which the base station 100 will transmit signals. Each channel encoder 104 receives the data to be transmitted on the particular frequency associated with the given channel encoder 104. The data is placed in a suitable form for transmission. This may include digitising the data, encoding the data, interleaving the data and/or any other step required to be carried out. As mentioned hereinbefore, each channel is on a different frequency after the</p>

Claim No.	'204 Patent	Exemplary Evidence of Anticipation and/or Obviousness
		<p>modulator. The signals output by the channel encoders 104 are in digital form and are at a baseband frequency. Coding, interleaving etc is performed on the digital baseband signals.” 4:35-36.</p> <p>“The output of each channel encoder 104 is input to a respective digital modulator 106. Each digital modulator 106 also receives two outputs from the adaptive predistorter 108. The first output from the predistorter 108 provides one or more amplitude coefficients which are used to predistort the signal which is output by the digital modulator to compensate for the non linearity of an amplifier 122 with respect to amplitude. The second output from the predistorter 108 provides one or more phase coefficients which are used to predistort the signal which is output by the modulator 106 to compensate for phase distortion provided by the amplifier 122. The amplifier 122 will be described in more detail hereinafter.” 4:48-60.</p> <p>“The predistortion to compensate for the phase and amplitude distortion introduced by the amplifier 122 can take place at the same time. The predistortion can be performed during or more preferably after the modulation has been carried out by the modulator 106.” 5:6-10.</p> <p>“The output of the second bandpass filter 120 is input to the power amplifier 122 which amplifies the received input. The output of the amplifier 122 is input to a third bandpass filter 124 which is arranged to filter out any signal components introduced by the amplifier 122 which fall outside the radio frequency band of the signals to be transmitted. The output of the third bandpass filter 124 is passed to an antenna 126 which transmits the signals to the terminals in the cell associated with the base station.” 5:41-49.</p> <p>“The adaptive predistorter 108 does not, as in the first embodiment, have outputs connected to the digital modulators 106. The output of the combiner 110 is connected to the input of the predistorter 108. The output of the predistorter 108 is connected to the input of the digital to analogue convertor. The predistorter 108 thus predistorts the multicarrier output of the combiner 110 and outputs a predistorted multicarrier signal. The feedback path is the same in the first and second embodiments and accordingly the predistorter 108 operates in a similar manner to that shown in the first embodiment. However, phase correction is not applied and the amplitude correction is the</p>

Claim No.	'204 Patent	Exemplary Evidence of Anticipation and/or Obviousness
		<p>same for all frequencies. This solution is simple but may not provide the required performance in all cases.” 7:39-52.</p> <p>“Reference will now be made to FIG. 8 which shows a second predistorter 108 b which can be used in the second embodiment shown in FIG. 5. This second predistorter 108 comprises n subtractors 208 each of which receives an output from a respective one of the digital modulators. Each subtracter 208 also receives a corresponding input from the channelizer 140 as in the first embodiment. Each subtracter 208 thus receives two modulated signals. The two signals received by each subtracter 208 are subtracted one from the other to generate a difference signal. This output difference signal is input to the adaption algorithm block 204 which is the same as discussed in relation to the first predistorter of FIG. 7. As with the first predistorter of FIG. 7, the adaption algorithm block 204 also receives an input from the microcontroller 142 with information concerning the frequency. The adaption algorithm block 204 provides amplitude coefficients on its output which are output to the look-up table 200. Unlike the embodiment shown in FIG. 7, the look-up table receives the multicarrier signal from the combiner 110 which defines an address in the look-up table. Accordingly, the multicarrier signal is modified in accordance with the amplitude values from the look-up table and output to the digital to analogue convertor 112.” 7:53-8:8.</p> <p>“Reference is now made to FIG. 10 which shows a possible construction of the channeliser 140. The channeliser comprises n blocks 220, with one block provided for each frequency. Each block of the channeliser 220 comprises an input for receiving the output of the analogue to digital converter 138 and a frequency control signal from the microcontroller 142. The output from the analogue to digital converter 138 is input to first and second multipliers 222 and 224. The first multiplier 222 produces the I or in-band, component of the input signal whilst the second multiplier 224 produces the Q, or quadrature-phase component of the input signal. Each of the multipliers 222 and 224 receives a frequency from the numerically controlled oscillator 226. The frequency of the oscillator 226 is controlled by the frequency control input. The output of the oscillator 226 is connected directly to one of the multipliers 222 whilst the output for the second multipliers 224 is connected to a phase shifter 228 which shifts the phase of the output signal from the oscillator 226 by 90°. The phase shifted output signal of the oscillator 226 is input to the second multipliers 224.” 8:9-28.</p>

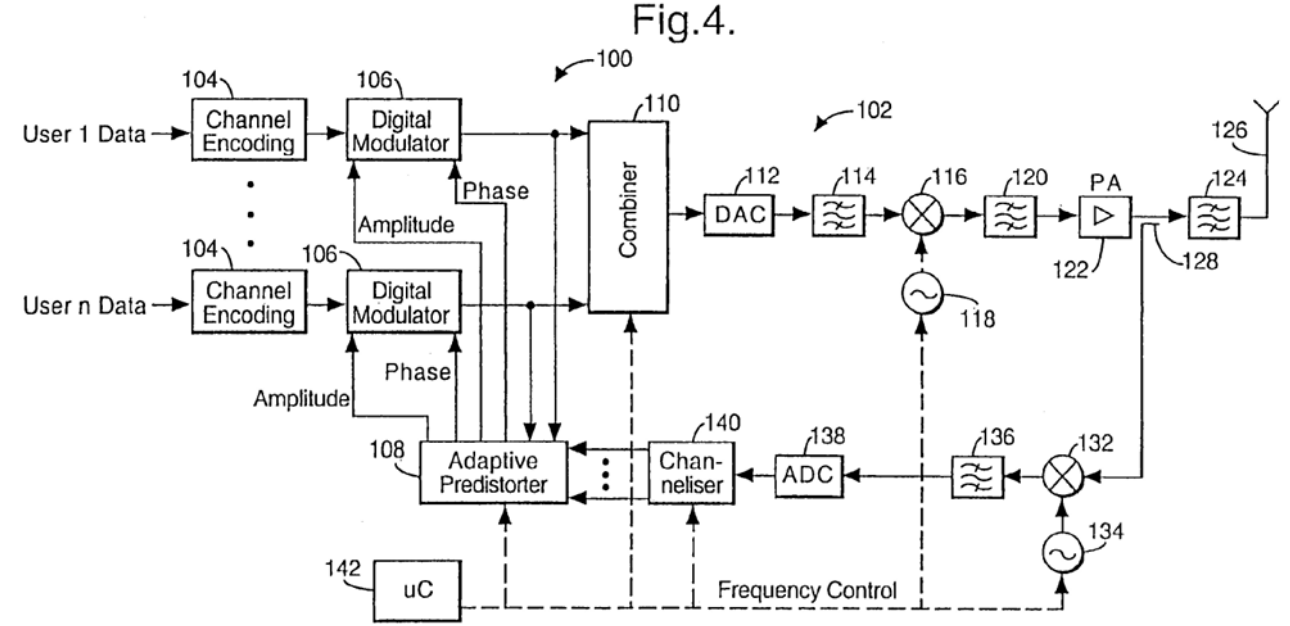
Claim No.	'204 Patent	Exemplary Evidence of Anticipation and/or Obviousness
		<p data-bbox="837 188 2123 292">“The output of each of the first and second multipliers 222 and 224 are connected to filters 230 and 232 which are arranged to filter out signal components introduced by the respective multipliers as well as other carriers within the multicarrier signal.” 8:29-33.</p> <p data-bbox="837 331 2123 547">“In the embodiments where the composite signal is predistorted, the combiner output consists of amplitude words, the correction occurring by adjusting the magnitude of the words. Nonlinearities in the amplifier output could be compensated by correcting the magnitude of the combiner output words with an inverse function. The correction may thus be dependent on the particular combiner output. This might occur by indexing a look-up table with the combiner output word and outputting the respective contents to the digital to analogue converter.” 9:18-27.</p> <div data-bbox="837 592 2123 1220"> <p data-bbox="1464 592 1570 635">Fig.4.</p>  </div> <p data-bbox="837 1265 925 1297">Fig. 4.</p>

Claim No.	'204 Patent	Exemplary Evidence of Anticipation and/or Obviousness
		<p style="text-align: center;">Fig.5.</p> <p style="text-align: center;">Fig. 5.</p>

Claim No.	'204 Patent	Exemplary Evidence of Anticipation and/or Obviousness
-----------	-------------	---

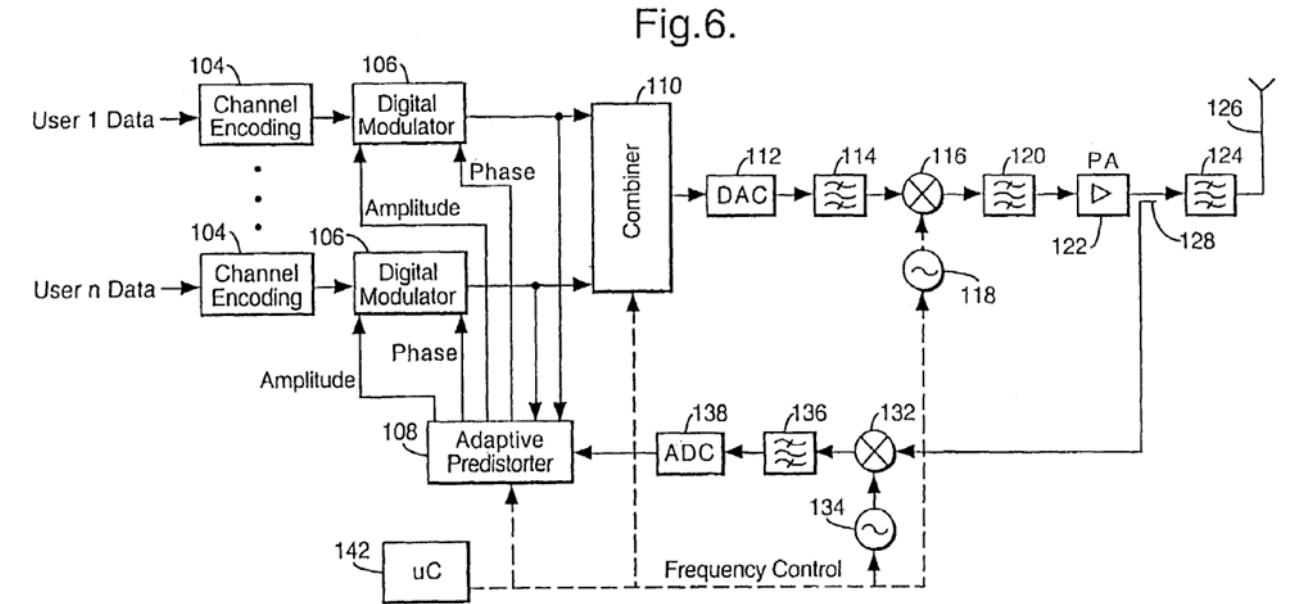
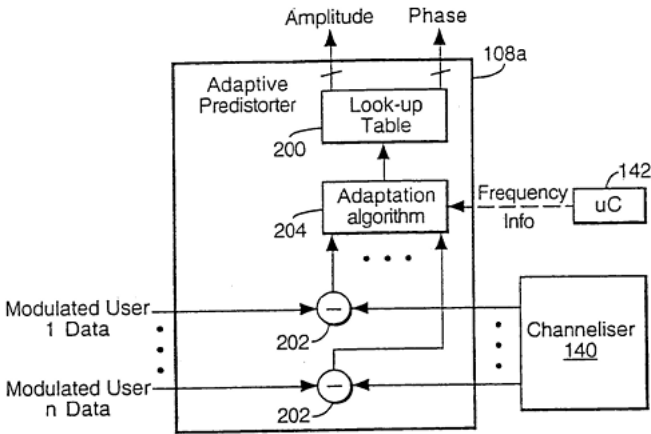
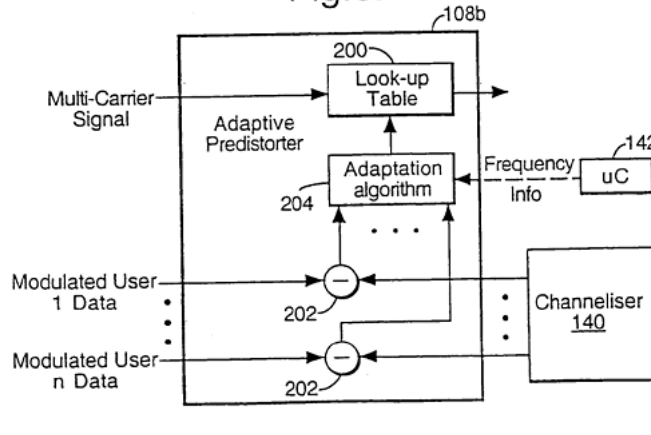
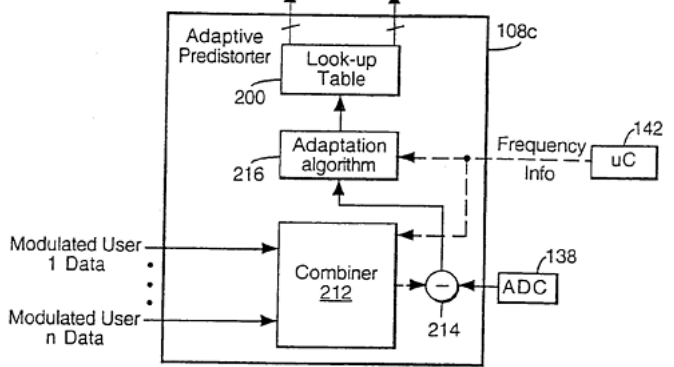
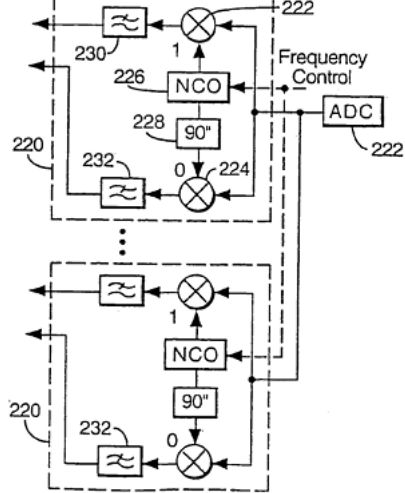

Fig. 6.

Claim No.	'204 Patent	Exemplary Evidence of Anticipation and/or Obviousness
		<p data-bbox="1144 188 1245 225">Fig.7.</p>  <p data-bbox="1144 788 1245 825">Fig.8.</p>  <p data-bbox="837 1286 1014 1323">Figs. 7 and 8.</p>

Claim No.	'204 Patent	Exemplary Evidence of Anticipation and/or Obviousness
		<p data-bbox="996 183 1276 223">Fig.9. Amplitude Phase</p>  <p data-bbox="974 678 1120 718">Fig.10.</p> <p data-bbox="974 718 1344 750">Principle of an NCO-Based Channeliser</p>  <p data-bbox="840 1284 985 1324">Figs. 9-10.</p>

Claim No.	'204 Patent	Exemplary Evidence of Anticipation and/or Obviousness
1[b]	a concurrent digital multi-band predistortion block configured to effect predistortion of the modulated concurrent multi-band signals to compensate for a non-linearity of the power amplifier; and	<p>Posti discloses and/or renders obvious a concurrent digital multi-band predistortion block configured to effect predistortion of the modulated concurrent multi-band signals to compensate for a non-linearity of the power amplifier.</p> <p><i>See, e.g.,</i></p> <p>“A multi frequency carrier transmitter comprises input means for receiving a plurality of different digital signals to be transmitted. The different signals are to be transmitted on different carrier frequencies. Amplifier means receive a composite signal comprising the different signals at the respective carrier frequencies and amplify the composite signal. Predistortion means predistort the plurality of digital signals prior to amplification of the composite signal by the amplification means. The predistortion provided by the predistortion means is subsequently altered in dependence on the difference between the input signals and the output at the amplifier means.” Abstract.</p> <p>“The present invention relates to a transmitter and a method of transmitting and in particular, but not exclusively, for use in a telecommunications network.”</p> <p>“According to one aspect of the present invention, there is provided a multi frequency carrier transmitter comprising input means for receiving a plurality of different digital signals to be transmitted, said different signals to be transmitted on different carrier frequencies; amplifier means for receiving a composite signal comprising said different signals at the respective carrier frequencies and amplifying said composite signal; and predistortion means for predistorting said plurality of digital signals prior to amplification of the composite signal by said amplification means, said predistortion provided by said predistortion means being subsequently altered in dependence on the difference between said input signals and the output at said amplifier means.” 2:43-55.</p> <p>“Accordingly, embodiments of the present invention provide a multi carrier transmitter which is able to deal with the problems of nonlinearity by using predistortion. The predistortion can be implemented more simply than the feedback method discussed in the prior art.” 2:55-60.</p>

Claim No.	'204 Patent	Exemplary Evidence of Anticipation and/or Obviousness
		<p>“The output of the second bandpass filter 120 is input to the power amplifier 122 which amplifies the received input. The output of the amplifier 122 is input to a third bandpass filter 124 which is arranged to filter out any signal components introduced by the amplifier 122 which fall outside the radio frequency band of the signals to be transmitted. The output of the third bandpass filter 124 is passed to an antenna 126 which transmits the signals to the terminals in the cell associated with the base station.” 5:41-49.</p> <p>“The input means are preferably arranged to separately receive each of the different signals. Combiner means are preferably provided between the input means and the amplifier means for combining said plurality of different signals to provide a composite signal. This may be the composite signal input to the amplifier means or may be a composite signal at a lower, intermediate frequency. In the latter case, that composite signal at a lower frequency would be upconverted to provide the composite signal input to the amplifier means.” 2:61-3:3.</p> <p>“A feedback path may be arranged between the amplifying means and the predistorting means. Preferably, the predistorting means is arranged to compare the output from the amplifying means from the feedback path with the signals received by the receiving means and to provide, if necessary, at least one new predistortion value to be applied to at least one subsequent signal received by the receiving means. In this way, the predistorting means can adapt to changes in the operating conditions of the amplifier means.” 3:14-21.</p> <p>“Preferably, means are provided in the feedback path for separating the output of the amplifying means into a plurality of different signals. The predistorting means is preferably arranged to compare each of the separated signals with the corresponding signals received from the input means and to determine if the at least one predistortion value needs to be altered.” 3:23-29.</p> <p>“Alternatively, the predistorting means is arranged to compare the composite signal from the amplifying means with a plurality of different signals to provide, if necessary, the at least one new predistortion value.” 3:30-33.</p>

Claim No.	'204 Patent	Exemplary Evidence of Anticipation and/or Obviousness
		<p>“The amplifier means is preferably a nonlinear amplifier. The predistortion means is preferably arranged to compensate for the nonlinearity of the phase and/or amplitude of the output of the amplifier.” 3:45-58.</p> <p>“A digital to analogue converter may be provided for converting the plurality of signals to analogue form before said signals are amplified by said amplifier means.</p> <p>The transmitter is preferably incorporated in a base station or alternatively in a mobile station.</p> <p>According to a second aspect of the present invention, there is provided a multi carrier frequency transmission method comprising the steps of receiving a plurality of different digital signals to be transmitted, said different signals to be transmitted on different carrier frequencies; combining said plurality of different signals to provide a composite signal comprising the different signals at the respective carrier frequencies; and amplifying said composite signal, wherein the method further comprises the steps of: predistorting the plurality of different digital signals prior to amplification of the composite signal by the amplification means; and altering the predistortion applied to subsequent signals in dependence on the difference between said different signals and the amplified signal.” 3:49-67.</p> <p>“Reference will now be made to FIG. 4 which shows a first embodiment of the present invention. In particular, the transmit part 102 of the base station 100 is shown. The base station 100 is in a cellular system of the type shown in FIG. 1.” 4:30-34.</p> <p>“The transmit part 102 of the base station 100 comprises N channel encoders 104 where N is the number of different frequencies on which the base station 100 will transmit signals. Each channel encoder 104 receives the data to be transmitted on the particular frequency associated with the given channel encoder 104. The data is placed in a suitable form for transmission. This may include digitising the data, encoding the data, interleaving the data and/or any other step required to be carried out. As mentioned hereinbefore, each channel is on a different frequency after the modulator. The signals output by the channel encoders 104 are in digital form and are at a baseband frequency. Coding, interleaving etc is performed on the digital baseband signals.” 4:35-36.</p>

Claim No.	'204 Patent	Exemplary Evidence of Anticipation and/or Obviousness
		<p>“The output of each channel encoder 104 is input to a respective digital modulator 106. Each digital modulator 106 also receives two outputs from the adaptive predistorter 108. The first output from the predistorter 108 provides one or more amplitude coefficients which are used to predistort the signal which is output by the digital modulator to compensate for the non linearity of an amplifier 122 with respect to amplitude. The second output from the predistorter 108 provides one or more phase coefficients which are used to predistort the signal which is output by the modulator 106 to compensate for phase distortion provided by the amplifier 122. The amplifier 122 will be described in more detail hereinafter.” 4:48-60.</p> <p>“The predistortion to compensate for the phase and amplitude distortion introduced by the amplifier 122 can take place at the same time. The predistortion can be performed during or more preferably after the modulation has been carried out by the modulator 106.” 5:6-10.</p> <p>“The output of the second bandpass filter 120 is input to the power amplifier 122 which amplifies the received input. The output of the amplifier 122 is input to a third bandpass filter 124 which is arranged to filter out any signal components introduced by the amplifier 122 which fall outside the radio frequency band of the signals to be transmitted. The output of the third bandpass filter 124 is passed to an antenna 126 which transmits the signals to the terminals in the cell associated with the base station.” 5:41-49.</p> <p>“The adaptive predistorter 108 does not, as in the first embodiment, have outputs connected to the digital modulators 106. The output of the combiner 110 is connected to the input of the predistorter 108. The output of the predistorter 108 is connected to the input of the digital to analogue convertor. The predistorter 108 thus predistorts the multicarrier output of the combiner 110 and outputs a predistorted multicarrier signal. The feedback path is the same in the first and second embodiments and accordingly the predistorter 108 operates in a similar manner to that shown in the first embodiment. However, phase correction is not applied and the amplitude correction is the same for all frequencies. This solution is simple but may not provide the required performance in all cases.” 7:39-52.</p> <p>“In the embodiments where the composite signal is predistorted, the combiner output consists of amplitude words, the correction occurring by adjusting the magnitude of the words. Nonlinearities in the amplifier output could be compensated by correcting the magnitude of the combiner output</p>

Claim No.	'204 Patent	Exemplary Evidence of Anticipation and/or Obviousness
		<p>words with an inverse function. The correction may thus be dependent on the particular combiner output. This might occur by indexing a look-up table with the combiner output word and outputting the respective contents to the digital to analogue converter.” 9:18-27.</p> <p style="text-align: center;">Fig.4.</p> <p style="text-align: center;">Fig. 4.</p>

Claim No.	'204 Patent	Exemplary Evidence of Anticipation and/or Obviousness
		<p style="text-align: center;">Fig.5.</p> <p style="text-align: center;">Fig. 5.</p>

Claim No.	'204 Patent	Exemplary Evidence of Anticipation and/or Obviousness
-----------	-------------	---

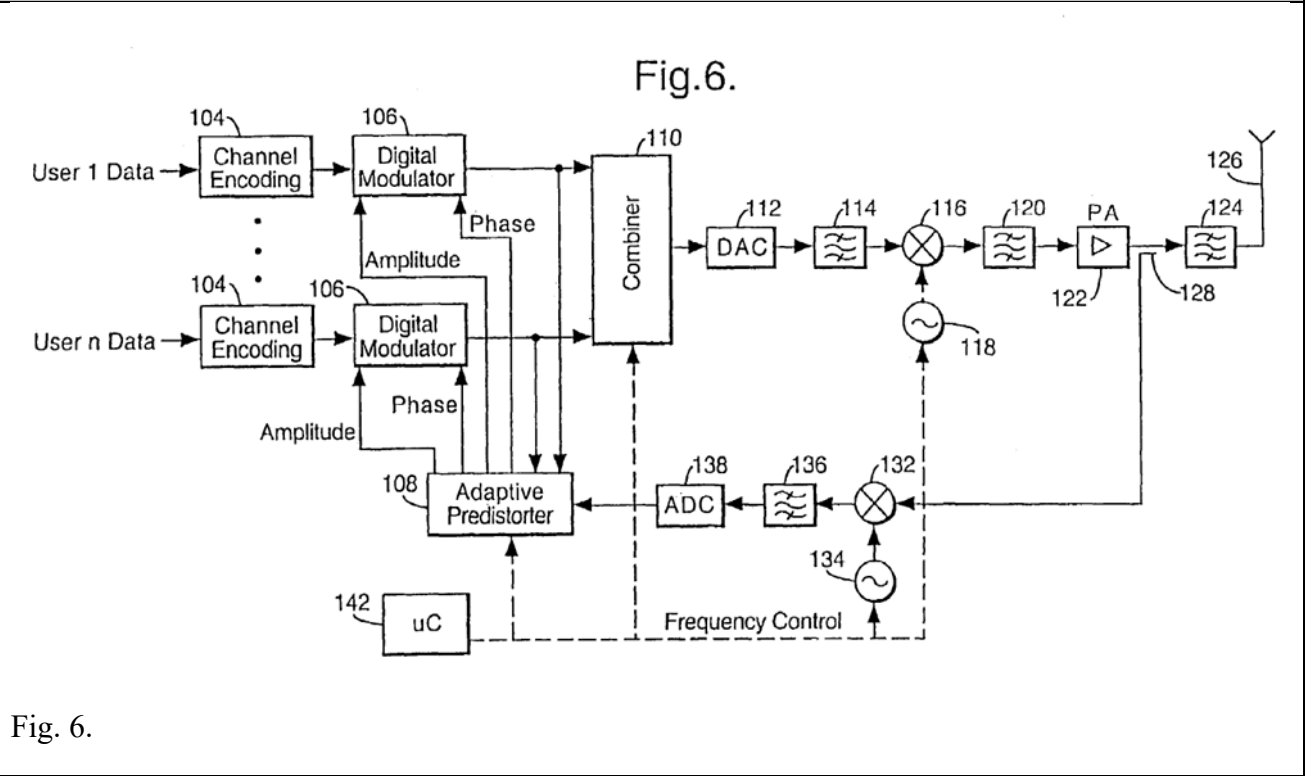

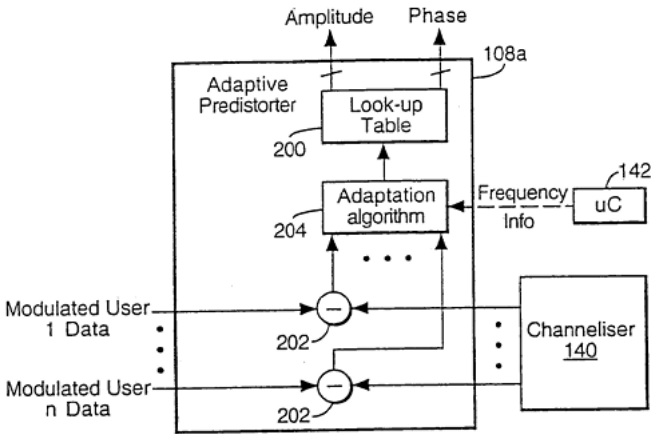
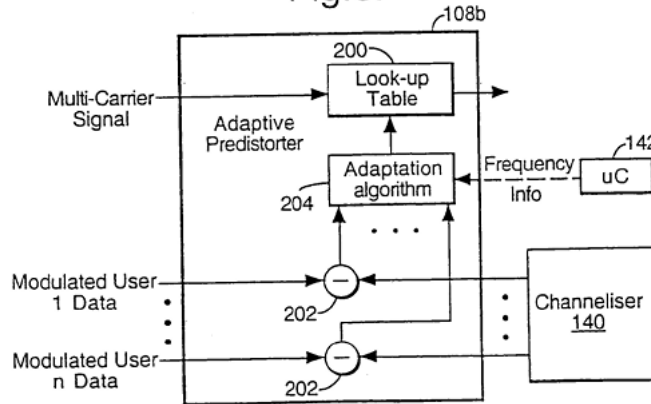
Claim No.	'204 Patent	Exemplary Evidence of Anticipation and/or Obviousness
		<p data-bbox="1144 188 1245 225">Fig.7.</p>  <p data-bbox="1144 788 1245 825">Fig.8.</p>  <p data-bbox="837 1286 1014 1323">Figs. 7 and 8.</p>

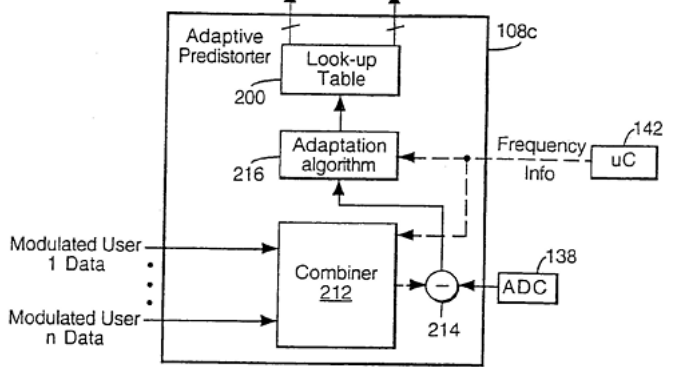
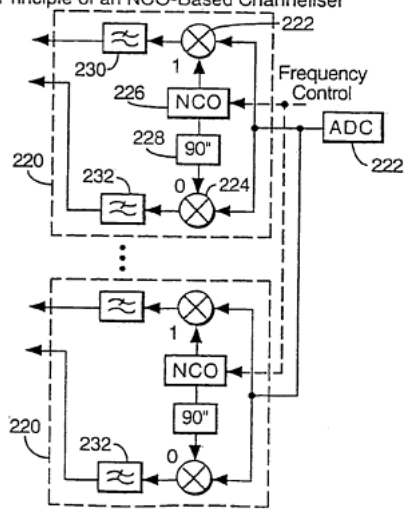
Claim No.	'204 Patent	Exemplary Evidence of Anticipation and/or Obviousness
		<p data-bbox="996 183 1276 223">Fig.9. Amplitude Phase</p>  <p data-bbox="974 678 1332 718">Fig.10. Principle of an NCO-Based Channeliser</p>  <p data-bbox="840 1284 985 1324">Figs. 9-10.</p>

Claim No.	'204 Patent	Exemplary Evidence of Anticipation and/or Obviousness
1[c]	a signal observation feedback loop configured to effect concurrent sampling of the amplified concurrent multi-band signals at a subsampling frequency lower than twice a highest signal frequency in the amplified concurrent multi-band signals.	<p>Posti discloses and/or renders obvious a signal observation feedback loop configured to effect concurrent sampling of the amplified concurrent multi-band signals at a subsampling frequency lower than twice a highest signal frequency in the amplified concurrent multi-band signals.</p> <p><i>See, e.g.,</i></p> <p>“A multi frequency carrier transmitter comprises input means for receiving a plurality of different digital signals to be transmitted. The different signals are to be transmitted on different carrier frequencies. Amplifier means receive a composite signal comprising the different signals at the respective carrier frequencies and amplify the composite signal. Predistortion means predistort the plurality of digital signals prior to amplification of the composite signal by the amplification means. The predistortion provided by the predistortion means is subsequently altered in dependence on the difference between the input signals and the output at the amplifier means.” Abstract.</p> <p>“The present invention relates to a transmitter and a method of transmitting and in particular, but not exclusively, for use in a telecommunications network.”</p> <p>“The output of each transmit path 14–14' is connected to the input of a combiner 22 which combines the signals from each path 14–14' to provide a multicarrier signal. The output of the combiner 22 is connected to an antenna 24 which transmits the multicarrier signal containing each of the N different channels to the terminals in the cell served by the base station.” 1:53-59.</p> <p>“According to one aspect of the present invention, there is provided a multi frequency carrier transmitter comprising input means for receiving a plurality of different digital signals to be transmitted, said different signals to be transmitted on different carrier frequencies; amplifier means for receiving a composite signal comprising said different signals at the respective carrier frequencies and amplifying said composite signal; and predistortion means for predistorting said plurality of digital signals prior to amplification of the composite signal by said amplification means, said predistortion provided by said predistortion means being subsequently altered in dependence on the difference between said input signals and the output at said amplifier means.” 2:43-55.</p>

Claim No.	'204 Patent	Exemplary Evidence of Anticipation and/or Obviousness
		<p>“Accordingly, embodiments of the present invention provide a multi carrier transmitter which is able to deal with the problems of nonlinearity by using predistortion. The predistortion can be implemented more simply than the feedback method discussed in the prior art.” 2:55-60.</p> <p>“The output of the second bandpass filter 120 is input to the power amplifier 122 which amplifies the received input. The output of the amplifier 122 is input to a third bandpass filter 124 which is arranged to filter out any signal components introduced by the amplifier 122 which fall outside the radio frequency band of the signals to be transmitted. The output of the third bandpass filter 124 is passed to an antenna 126 which transmits the signals to the terminals in the cell associated with the base station.” 5:41-49.</p> <p>“The input means are preferably arranged to separately receive each of the different signals. Combiner means are preferably provided between the input means and the amplifier means for combining said plurality of different signals to provide a composite signal. This may be the composite signal input to the amplifier means or may be a composite signal at a lower, intermediate frequency. In the latter case, that composite signal at a lower frequency would be upconverted to provide the composite signal input to the amplifier means.” 2:61-3:3.</p> <p>“A feedback path may be arranged between the amplifying means and the predistorting means. Preferably, the predistorting means is arranged to compare the output from the amplifying means from the feedback path with the signals received by the receiving means and to provide, if necessary, at least one new predistortion value to be applied to at least one subsequent signal received by the receiving means. In this way, the predistorting means can adapt to changes in the operating conditions of the amplifier means.” 3:14-21.</p> <p>“Preferably, means are provided in the feedback path for separating the output of the amplifying means into a plurality of different signals. The predistorting means is preferably arranged to compare each of the separated signals with the corresponding signals received from the input means and to determine if the at least one predistortion value needs to be altered.” 3:23-29.</p>

Claim No.	'204 Patent	Exemplary Evidence of Anticipation and/or Obviousness
		<p>“Alternatively, the predistorting means is arranged to compare the composite signal from the amplifying means with a plurality of different signals to provide, if necessary, the at least one new predistortion value.” 3:30-33.</p> <p>“The amplifier means is preferably a nonlinear amplifier. The predistortion means is preferably arranged to compensate for the nonlinearity of the phase and/or amplitude of the output of the amplifier.” 3:45-58.</p> <p>“A digital to analogue converter may be provided for converting the plurality of signals to analogue form before said signals are amplified by said amplifier means.</p> <p>The transmitter is preferably incorporated in a base station or alternatively in a mobile station.</p> <p>According to a second aspect of the present invention, there is provided a multi carrier frequency transmission method comprising the steps of receiving a plurality of different digital signals to be transmitted, said different signals to be transmitted on different carrier frequencies; combining said plurality of different signals to provide a composite signal comprising the different signals at the respective carrier frequencies; and amplifying said composite signal, wherein the method further comprises the steps of: predistorting the plurality of different digital signals prior to amplification of the composite signal by the amplification means; and altering the predistortion applied to subsequent signals in dependence on the difference between said different signals and the amplified signal.” 3:49-67.</p> <p>“Reference will now be made to FIG. 4 which shows a first embodiment of the present invention. In particular, the transmit part 102 of the base station 100 is shown. The base station 100 is in a cellular system of the type shown in FIG. 1.” 4:30-34.</p> <p>“The transmit part 102 of the base station 100 comprises N channel encoders 104 where N is the number of different frequencies on which the base station 100 will transmit signals. Each channel encoder 104 receives the data to be transmitted on the particular frequency associated with the given channel encoder 104. The data is placed in a suitable form for transmission. This may include digitising the data, encoding the data, interleaving the data and/or any other step required to be carried out. As mentioned hereinbefore, each channel is on a different frequency after the</p>

Claim No.	'204 Patent	Exemplary Evidence of Anticipation and/or Obviousness
		<p>modulator. The signals output by the channel encoders 104 are in digital form and are at a baseband frequency. Coding, interleaving etc is performed on the digital baseband signals.” 4:35-36.</p> <p>“The output of each channel encoder 104 is input to a respective digital modulator 106. Each digital modulator 106 also receives two outputs from the adaptive predistorter 108. The first output from the predistorter 108 provides one or more amplitude coefficients which are used to predistort the signal which is output by the digital modulator to compensate for the non linearity of an amplifier 122 with respect to amplitude. The second output from the predistorter 108 provides one or more phase coefficients which are used to predistort the signal which is output by the modulator 106 to compensate for phase distortion provided by the amplifier 122. The amplifier 122 will be described in more detail hereinafter.” 4:48-60.</p> <p>“The predistortion to compensate for the phase and amplitude distortion introduced by the amplifier 122 can take place at the same time. The predistortion can be performed during or more preferably after the modulation has been carried out by the modulator 106.” 5:6-10.</p> <p>“The output of the second bandpass filter 120 is input to the power amplifier 122 which amplifies the received input. The output of the amplifier 122 is input to a third bandpass filter 124 which is arranged to filter out any signal components introduced by the amplifier 122 which fall outside the radio frequency band of the signals to be transmitted. The output of the third bandpass filter 124 is passed to an antenna 126 which transmits the signals to the terminals in the cell associated with the base station.” 5:41-49.</p> <p>“The adaptive predistorter 108 does not, as in the first embodiment, have outputs connected to the digital modulators 106. The output of the combiner 110 is connected to the input of the predistorter 108. The output of the predistorter 108 is connected to the input of the digital to analogue convertor. The predistorter 108 thus predistorts the multicarrier output of the combiner 110 and outputs a predistorted multicarrier signal. The feedback path is the same in the first and second embodiments and accordingly the predistorter 108 operates in a similar manner to that shown in the first embodiment. However, phase correction is not applied and the amplitude correction is the</p>

Claim No.	'204 Patent	Exemplary Evidence of Anticipation and/or Obviousness
		<p>same for all frequencies. This solution is simple but may not provide the required performance in all cases.” 7:39-52.</p> <p>“Reference will now be made to FIG. 8 which shows a second predistorter 108 b which can be used in the second embodiment shown in FIG. 5. This second predistorter 108 comprises n subtractors 208 each of which receives an output from a respective one of the digital modulators. Each subtracter 208 also receives a corresponding input from the channelizer 140 as in the first embodiment. Each subtracter 208 thus receives two modulated signals. The two signals received by each subtracter 208 are subtracted one from the other to generate a difference signal. This output difference signal is input to the adaption algorithm block 204 which is the same as discussed in relation to the first predistorter of FIG. 7. As with the first predistorter of FIG. 7, the adaption algorithm block 204 also receives an input from the microcontroller 142 with information concerning the frequency. The adaption algorithm block 204 provides amplitude coefficients on its output which are output to the look-up table 200. Unlike the embodiment shown in FIG. 7, the look-up table receives the multicarrier signal from the combiner 110 which defines an address in the look-up table. Accordingly, the multicarrier signal is modified in accordance with the amplitude values from the look-up table and output to the digital to analogue convertor 112.” 7:53-8:8.</p> <p>“Reference is now made to FIG. 10 which shows a possible construction of the channeliser 140. The channeliser comprises n blocks 220, with one block provided for each frequency. Each block of the channeliser 220 comprises an input for receiving the output of the analogue to digital converter 138 and a frequency control signal from the microcontroller 142. The output from the analogue to digital converter 138 is input to first and second multipliers 222 and 224. The first multiplier 222 produces the I or in-band, component of the input signal whilst the second multiplier 224 produces the Q, or quadrature-phase component of the input signal. Each of the multipliers 222 and 224 receives a frequency from the numerically controlled oscillator 226. The frequency of the oscillator 226 is controlled by the frequency control input. The output of the oscillator 226 is connected directly to one of the multipliers 222 whilst the output for the second multipliers 224 is connected to a phase shifter 228 which shifts the phase of the output signal from the oscillator 226 by 90°. The phase shifted output signal of the oscillator 226 is input to the second multipliers 224.” 8:9-28.</p>

Claim No.	'204 Patent	Exemplary Evidence of Anticipation and/or Obviousness
		<p>“The output of each of the first and second multipliers 222 and 224 are connected to filters 230 and 232 which are arranged to filter out signal components introduced by the respective multipliers as well as other carriers within the multicarrier signal.” 8:29-33.</p> <p>“In the embodiments where the composite signal is predistorted, the combiner output consists of amplitude words, the correction occurring by adjusting the magnitude of the words. Nonlinearities in the amplifier output could be compensated by correcting the magnitude of the combiner output words with an inverse function. The correction may thus be dependent on the particular combiner output. This might occur by indexing a look-up table with the combiner output word and outputting the respective contents to the digital to analogue converter.” 9:18-27.</p> <div data-bbox="840 590 2116 1220" style="text-align: center;"> </div> <p>Fig. 4.</p>

Claim No.	'204 Patent	Exemplary Evidence of Anticipation and/or Obviousness
		<p style="text-align: center;">Fig.5.</p> <p style="text-align: center;">Fig. 5.</p>

Claim No.	'204 Patent	Exemplary Evidence of Anticipation and/or Obviousness
-----------	-------------	---

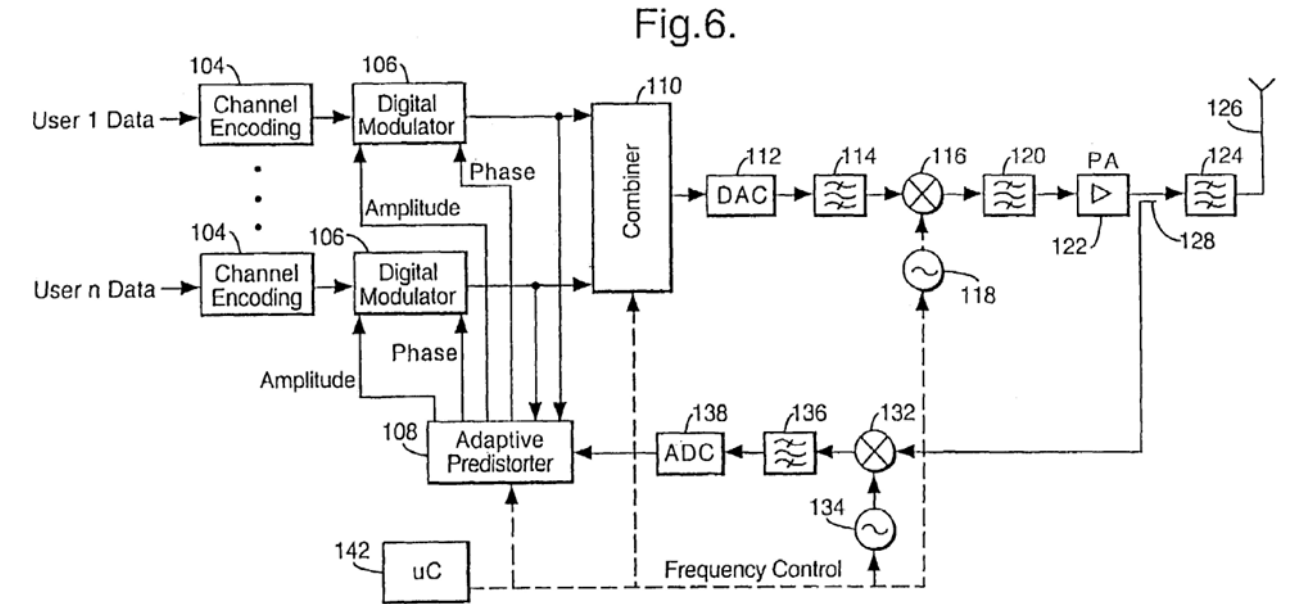
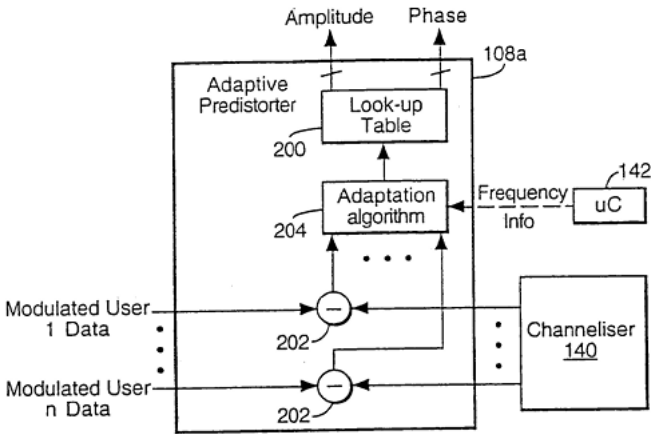
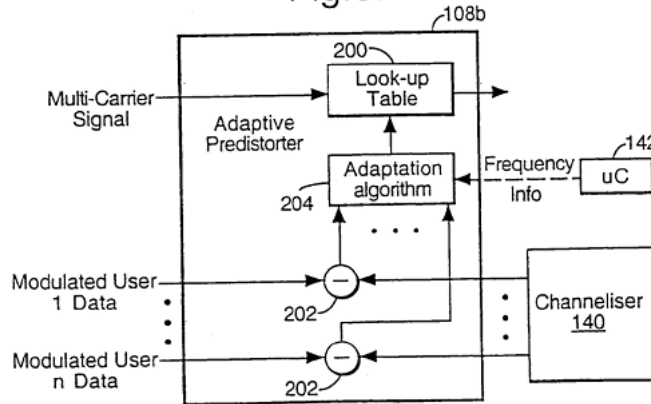
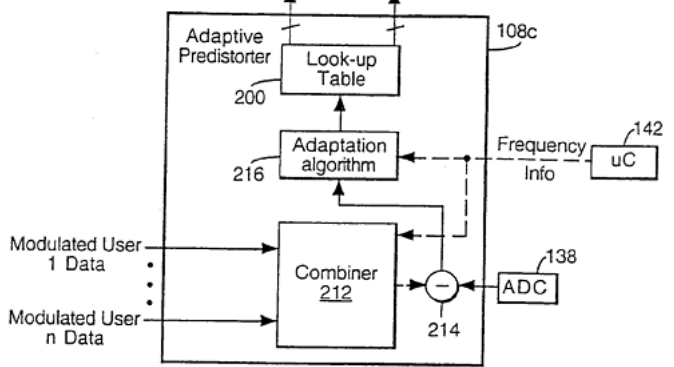
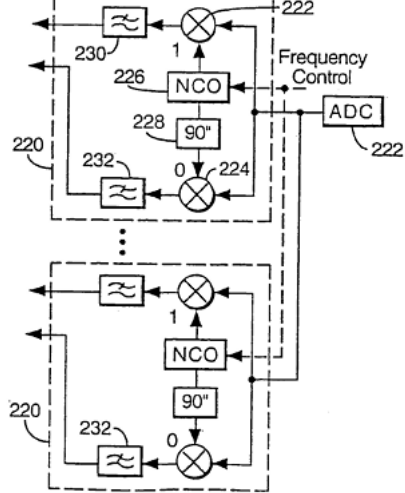

Fig. 6.

Claim No.	'204 Patent	Exemplary Evidence of Anticipation and/or Obviousness
		<p data-bbox="1144 188 1245 225">Fig.7.</p>  <p data-bbox="1144 788 1245 825">Fig.8.</p>  <p data-bbox="837 1286 1014 1323">Figs. 7 and 8.</p>

Claim No.	'204 Patent	Exemplary Evidence of Anticipation and/or Obviousness
		<p data-bbox="996 183 1276 223">Fig.9. Amplitude Phase</p>  <p data-bbox="974 678 1120 718">Fig.10.</p> <p data-bbox="974 718 1344 750">Principle of an NCO-Based Channeliser</p>  <p data-bbox="840 1284 985 1324">Figs. 9-10.</p>

Claim No.	'204 Patent	Exemplary Evidence of Anticipation and/or Obviousness
2	<p>The transmitter of claim 1, wherein said concurrent digital multi-band predistortion block further comprises:</p> <p>a plurality of digital baseband signal predistorter blocks, each baseband signal predistorter block having a plurality of first inputs and a single output, the plurality of first inputs corresponding in number to the multiple bands of the multi-band transmitter and each first input corresponding to a single frequency channel.</p>	<p>Posti discloses and/or renders obvious the transmitter of claim 1, wherein said concurrent digital multi-band predistortion block further comprises: a plurality of digital baseband signal predistorter blocks, each baseband signal predistorter block having a plurality of first inputs and a single output, the plurality of first inputs corresponding in number to the multiple bands of the multi-band transmitter and each first input corresponding to a single frequency channel.</p> <p><i>See claim 1, supra, which is incorporated by reference herein.</i></p> <p><i>See also, e.g.,</i></p> <p>“A multi frequency carrier transmitter comprises input means for receiving a plurality of different digital signals to be transmitted. The different signals are to be transmitted on different carrier frequencies. Amplifier means receive a composite signal comprising the different signals at the respective carrier frequencies and amplify the composite signal. Predistortion means predistort the plurality of digital signals prior to amplification of the composite signal by the amplification means. The predistortion provided by the predistortion means is subsequently altered in dependence on the difference between the input signals and the output at the amplifier means.” Abstract.</p> <p>“The present invention relates to a transmitter and a method of transmitting and in particular, but not exclusively, for use in a telecommunications network.”</p> <p>“The output of each transmit path 14–14' is connected to the input of a combiner 22 which combines the signals from each path 14–14' to provide a multicarrier signal. The output of the combiner 22 is connected to an antenna 24 which transmits the multicarrier signal containing each of the N different channels to the terminals in the cell served by the base station.” 1:53-59.</p> <p>“According to one aspect of the present invention, there is provided a multi frequency carrier transmitter comprising input means for receiving a plurality of different digital signals to be transmitted, said different signals to be transmitted on different carrier frequencies; amplifier means for receiving a composite signal comprising said different signals at the respective carrier frequencies and amplifying said composite signal; and predistortion means for predistorting said</p>

Claim No.	'204 Patent	Exemplary Evidence of Anticipation and/or Obviousness
		<p>plurality of digital signals prior to amplification of the composite signal by said amplification means, said predistortion provided by said predistortion means being subsequently altered in dependence on the difference between said input signals and the output at said amplifier means.” 2:43-55.</p> <p>“Accordingly, embodiments of the present invention provide a multi carrier transmitter which is able to deal with the problems of nonlinearity by using predistortion. The predistortion can be implemented more simply than the feedback method discussed in the prior art.” 2:55-60.</p> <p>“The output of the second bandpass filter 120 is input to the power amplifier 122 which amplifies the received input. The output of the amplifier 122 is input to a third bandpass filter 124 which is arranged to filter out any signal components introduced by the amplifier 122 which fall outside the radio frequency band of the signals to be transmitted. The output of the third bandpass filter 124 is passed to an antenna 126 which transmits the signals to the terminals in the cell associated with the base station.” 5:41-49.</p> <p>“The input means are preferably arranged to separately receive each of the different signals. Combiner means are preferably provided between the input means and the amplifier means for combining said plurality of different signals to provide a composite signal. This may be the composite signal input to the amplifier means or may be a composite signal at a lower, intermediate frequency. In the latter case, that composite signal at a lower frequency would be upconverted to provide the composite signal input to the amplifier means.” 2:61-3:3.</p> <p>“A feedback path may be arranged between the amplifying means and the predistorting means. Preferably, the predistorting means is arranged to compare the output from the amplifying means from the feedback path with the signals received by the receiving means and to provide, if necessary, at least one new predistortion value to be applied to at least one subsequent signal received by the receiving means. In this way, the predistorting means can adapt to changes in the operating conditions of the amplifier means.” 3:14-21.</p> <p>“Preferably, means are provided in the feedback path for separating the output of the amplifying means into a plurality of different signals. The predistorting means is preferably arranged to</p>

Claim No.	'204 Patent	Exemplary Evidence of Anticipation and/or Obviousness
		<p>compare each of the separated signals with the corresponding signals received from the input means and to determine if the at least one predistortion value needs to be altered.” 3:23-29.</p> <p>“Alternatively, the predistorting means is arranged to compare the composite signal from the amplifying means with a plurality of different signals to provide, if necessary, the at least one new predistortion value.” 3:30-33.</p> <p>“The amplifier means is preferably a nonlinear amplifier. The predistortion means is preferably arranged to compensate for the nonlinearity of the phase and/or amplitude of the output of the amplifier.” 3:45-58.</p> <p>“A digital to analogue converter may be provided for converting the plurality of signals to analogue form before said signals are amplified by said amplifier means.</p> <p>The transmitter is preferably incorporated in a base station or alternatively in a mobile station.</p> <p>According to a second aspect of the present invention, there is provided a multi carrier frequency transmission method comprising the steps of receiving a plurality of different digital signals to be transmitted, said different signals to be transmitted on different carrier frequencies; combining said plurality of different signals to provide a composite signal comprising the different signals at the respective carrier frequencies; and amplifying said composite signal, wherein the method further comprises the steps of: predistorting the plurality of different digital signals prior to amplification of the composite signal by the amplification means; and altering the predistortion applied to subsequent signals in dependence on the difference between said different signals and the amplified signal.” 3:49-67.</p> <p>“Reference will now be made to FIG. 4 which shows a first embodiment of the present invention. In particular, the transmit part 102 of the base station 100 is shown. The base station 100 is in a cellular system of the type shown in FIG. 1.” 4:30-34.</p> <p>“The transmit part 102 of the base station 100 comprises N channel encoders 104 where N is the number of different frequencies on which the base station 100 will transmit signals. Each channel encoder 104 receives the data to be transmitted on the particular frequency associated with the</p>

Claim No.	'204 Patent	Exemplary Evidence of Anticipation and/or Obviousness
		<p>given channel encoder 104. The data is placed in a suitable form for transmission. This may include digitising the data, encoding the data, interleaving the data and/or any other step required to be carried out. As mentioned hereinbefore, each channel is on a different frequency after the modulator. The signals output by the channel encoders 104 are in digital form and are at a baseband frequency. Coding, interleaving etc is performed on the digital baseband signals.” 4:35-36.</p> <p>“The output of each channel encoder 104 is input to a respective digital modulator 106. Each digital modulator 106 also receives two outputs from the adaptive predistorter 108. The first output from the predistorter 108 provides one or more amplitude coefficients which are used to predistort the signal which is output by the digital modulator to compensate for the non linearity of an amplifier 122 with respect to amplitude. The second output from the predistorter 108 provides one or more phase coefficients which are used to predistort the signal which is output by the modulator 106 to compensate for phase distortion provided by the amplifier 122. The amplifier 122 will be described in more detail hereinafter.” 4:48-60.</p> <p>“The predistortion to compensate for the phase and amplitude distortion introduced by the amplifier 122 can take place at the same time. The predistortion can be performed during or more preferably after the modulation has been carried out by the modulator 106.” 5:6-10.</p> <p>“The output of the second bandpass filter 120 is input to the power amplifier 122 which amplifies the received input. The output of the amplifier 122 is input to a third bandpass filter 124 which is arranged to filter out any signal components introduced by the amplifier 122 which fall outside the radio frequency band of the signals to be transmitted. The output of the third bandpass filter 124 is passed to an antenna 126 which transmits the signals to the terminals in the cell associated with the base station.” 5:41-49.</p> <p>“The adaptive predistorter 108 does not, as in the first embodiment, have outputs connected to the digital modulators 106. The output of the combiner 110 is connected to the input of the predistorter 108. The output of the predistorter 108 is connected to the input of the digital to analogue convertor. The predistorter 108 thus predistorts the multicarrier output of the combiner 110 and outputs a predistorted multicarrier signal. The feedback path is the same in the first and second embodiments and accordingly the predistorter 108 operates in a similar manner to that shown in the</p>

Claim No.	'204 Patent	Exemplary Evidence of Anticipation and/or Obviousness
		<p>first embodiment. However, phase correction is not applied and the amplitude correction is the same for all frequencies. This solution is simple but may not provide the required performance in all cases.” 7:39-52.</p> <p>“Reference will now be made to FIG. 8 which shows a second predistorter 108 b which can be used in the second embodiment shown in FIG. 5. This second predistorter 108 comprises n subtractors 208 each of which receives an output from a respective one of the digital modulators. Each subtractor 208 also receives a corresponding input from the channelizer 140 as in the first embodiment. Each subtractor 208 thus receives two modulated signals. The two signals received by each subtractor 208 are subtracted one from the other to generate a difference signal. This output difference signal is input to the adaption algorithm block 204 which is the same as discussed in relation to the first predistorter of FIG. 7. As with the first predistorter of FIG. 7, the adaption algorithm block 204 also receives an input from the microcontroller 142 with information concerning the frequency. The adaption algorithm block 204 provides amplitude coefficients on its output which are output to the look-up table 200. Unlike the embodiment shown in FIG. 7, the look-up table receives the multicarrier signal from the combiner 110 which defines an address in the look-up table. Accordingly, the multicarrier signal is modified in accordance with the amplitude values from the look-up table and output to the digital to analogue convertor 112.” 7:53-8:8.</p> <p>“Reference is now made to FIG. 10 which shows a possible construction of the channeliser 140. The channeliser comprises n blocks 220, with one block provided for each frequency. Each block of the channeliser 220 comprises an input for receiving the output of the analogue to digital converter 138 and a frequency control signal from the microcontroller 142. The output from the analogue to digital converter 138 is input to first and second multipliers 222 and 224. The first multiplier 222 produces the I or in-band, component of the input signal whilst the second multiplier 224 produces the Q, or quadrature-phase component of the input signal. Each of the multipliers 222 and 224 receives a frequency from the numerically controlled oscillator 226. The frequency of the oscillator 226 is controlled by the frequency control input. The output of the oscillator 226 is connected directly to one of the multipliers 222 whilst the output for the second multipliers 224 is connected to a phase shifter 228 which shifts the phase of the output signal from the oscillator 226</p>

Claim No.	'204 Patent	Exemplary Evidence of Anticipation and/or Obviousness
		<p>by 90°. The phase shifted output signal of the oscillator 226 is input to the second multipliers 224.” 8:9-28.</p> <p>“The output of each of the first and second multipliers 222 and 224 are connected to filters 230 and 232 which are arranged to filter out signal components introduced by the respective multipliers as well as other carriers within the multicarrier signal.” 8:29-33.</p> <p>“In the embodiments where the composite signal is predistorted, the combiner output consists of amplitude words, the correction occurring by adjusting the magnitude of the words. Nonlinearities in the amplifier output could be compensated by correcting the magnitude of the combiner output words with an inverse function. The correction may thus be dependent on the particular combiner output. This might occur by indexing a look-up table with the combiner output word and outputting the respective contents to the digital to analogue converter.” 9:18-27.</p> <p style="text-align: center;">Fig.4.</p>

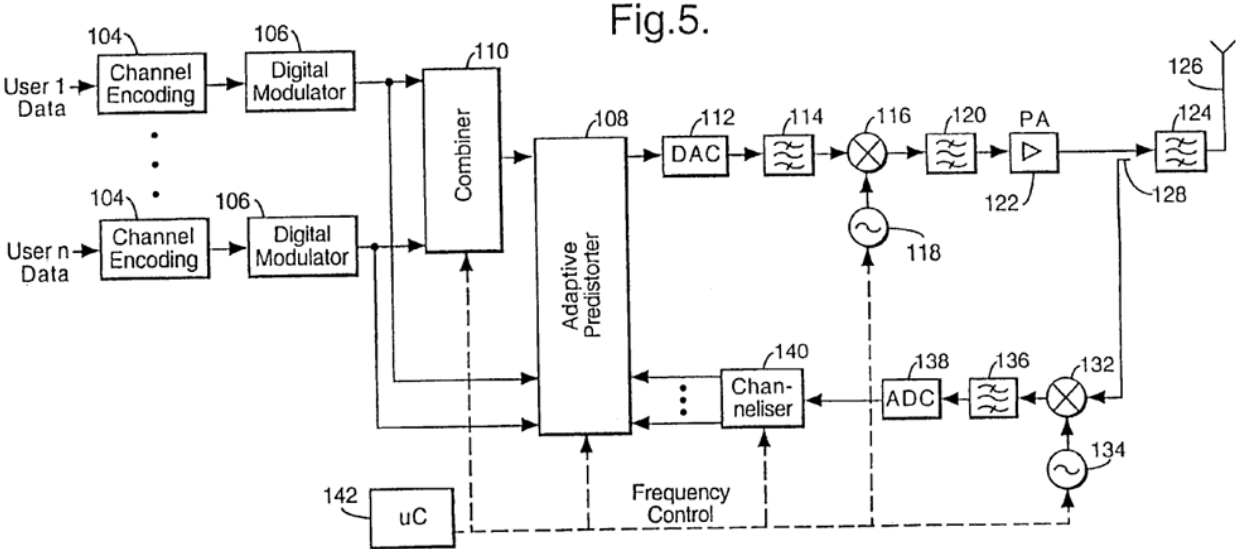
Claim No.	'204 Patent	Exemplary Evidence of Anticipation and/or Obviousness
		<p data-bbox="840 188 929 215">Fig. 4.</p>  <p data-bbox="1467 271 1579 311">Fig.5.</p> <p data-bbox="840 861 929 888">Fig. 5.</p>

Claim No.	'204 Patent	Exemplary Evidence of Anticipation and/or Obviousness
-----------	-------------	---

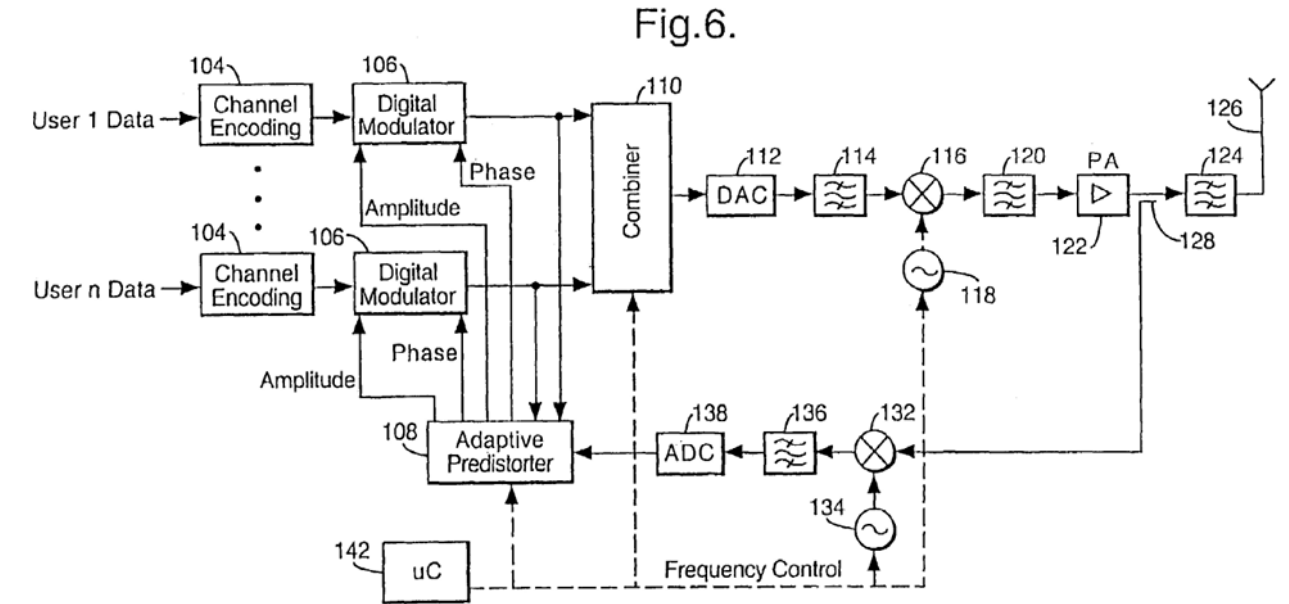
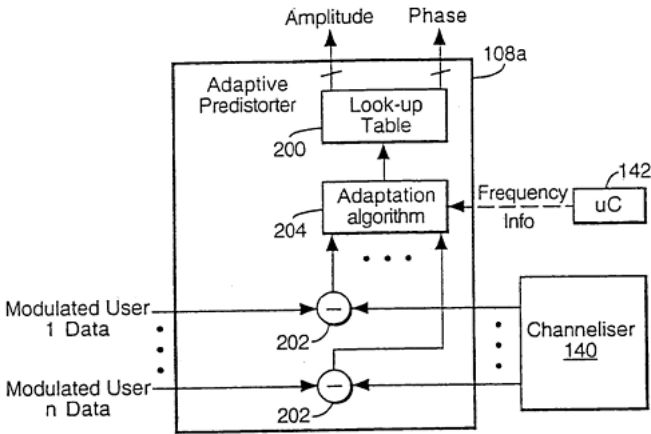
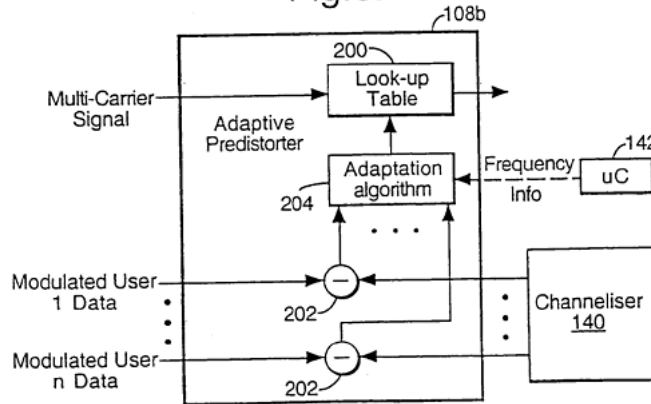
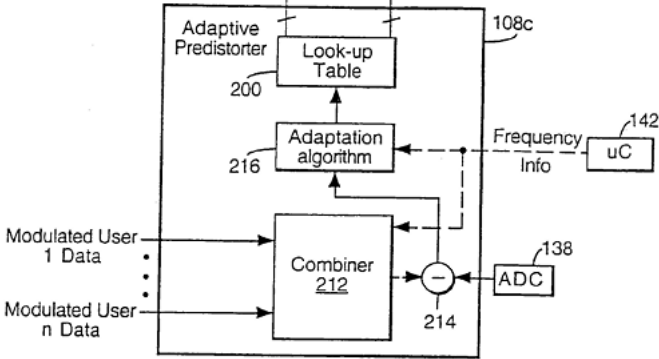
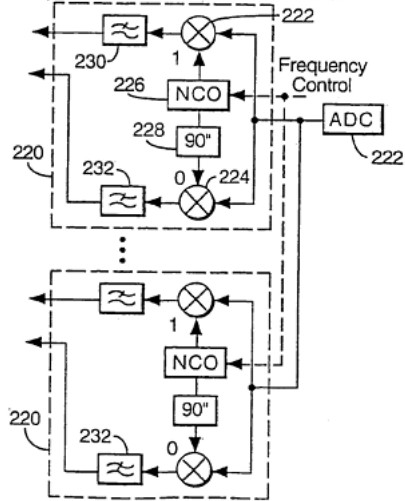

Fig. 6.

Claim No.	'204 Patent	Exemplary Evidence of Anticipation and/or Obviousness
		<p data-bbox="1144 188 1245 225">Fig.7.</p>  <p data-bbox="1144 788 1245 825">Fig.8.</p>  <p data-bbox="837 1286 1014 1323">Figs. 7 and 8.</p>

Claim No.	'204 Patent	Exemplary Evidence of Anticipation and/or Obviousness
		<p data-bbox="996 181 1276 215">Fig.9. Amplitude Phase</p>  <p data-bbox="981 678 1086 710">Fig.10.</p> <p data-bbox="981 718 1332 742">Principle of an NCO-Based Channeliser</p>  <p data-bbox="840 1284 974 1316">Figs. 9-10.</p>

Claim No.	'204 Patent	Exemplary Evidence of Anticipation and/or Obviousness
3[a]	<p>The transmitter of claim 2, wherein said concurrent digital multi-band predistortion block further comprises:</p> <p>a plurality of digital baseband signal predistorter blocks, each baseband signal predistorter block having a plurality of first inputs and a single output, the plurality of first inputs corresponding in number to the multiple bands of the multi-band transmitter and each first input corresponding to a single frequency channel and</p>	<p>Posti discloses and/or renders obvious the transmitter of claim 2, wherein said concurrent digital multi-band predistortion block further comprises: a plurality of digital baseband signal predistorter blocks, each baseband signal predistorter block having a plurality of first inputs and a single output, the plurality of first inputs corresponding in number to the multiple bands of the multi-band transmitter and each first input corresponding to a single frequency channel.</p> <p><i>See claim 2, supra, which is incorporated by reference herein.</i></p> <p><i>See, e.g.,</i></p> <p>“A multi frequency carrier transmitter comprises input means for receiving a plurality of different digital signals to be transmitted. The different signals are to be transmitted on different carrier frequencies. Amplifier means receive a composite signal comprising the different signals at the respective carrier frequencies and amplify the composite signal. Predistortion means predistort the plurality of digital signals prior to amplification of the composite signal by the amplification means. The predistortion provided by the predistortion means is subsequently altered in dependence on the difference between the input signals and the output at the amplifier means.” Abstract.</p> <p>“The present invention relates to a transmitter and a method of transmitting and in particular, but not exclusively, for use in a telecommunications network.”</p> <p>“The output of each transmit path 14–14' is connected to the input of a combiner 22 which combines the signals from each path 14–14' to provide a multicarrier signal. The output of the combiner 22 is connected to an antenna 24 which transmits the multicarrier signal containing each of the N different channels to the terminals in the cell served by the base station.” 1:53-59.</p> <p>“According to one aspect of the present invention, there is provided a multi frequency carrier transmitter comprising input means for receiving a plurality of different digital signals to be transmitted, said different signals to be transmitted on different carrier frequencies; amplifier means for receiving a composite signal comprising said different signals at the respective carrier frequencies and amplifying said composite signal; and predistortion means for predistorting said plurality of digital signals prior to amplification of the composite signal by said amplification</p>

Claim No.	'204 Patent	Exemplary Evidence of Anticipation and/or Obviousness
		<p>means, said predistortion provided by said predistortion means being subsequently altered in dependence on the difference between said input signals and the output at said amplifier means.” 2:43-55.</p> <p>“Accordingly, embodiments of the present invention provide a multi carrier transmitter which is able to deal with the problems of nonlinearity by using predistortion. The predistortion can be implemented more simply than the feedback method discussed in the prior art.” 2:55-60.</p> <p>“The output of the second bandpass filter 120 is input to the power amplifier 122 which amplifies the received input. The output of the amplifier 122 is input to a third bandpass filter 124 which is arranged to filter out any signal components introduced by the amplifier 122 which fall outside the radio frequency band of the signals to be transmitted. The output of the third bandpass filter 124 is passed to an antenna 126 which transmits the signals to the terminals in the cell associated with the base station.” 5:41-49.</p> <p>“The input means are preferably arranged to separately receive each of the different signals. Combiner means are preferably provided between the input means and the amplifier means for combining said plurality of different signals to provide a composite signal. This may be the composite signal input to the amplifier means or may be a composite signal at a lower, intermediate frequency. In the latter case, that composite signal at a lower frequency would be upconverted to provide the composite signal input to the amplifier means.” 2:61-3:3.</p> <p>“A feedback path may be arranged between the amplifying means and the predistorting means. Preferably, the predistorting means is arranged to compare the output from the amplifying means from the feedback path with the signals received by the receiving means and to provide, if necessary, at least one new predistortion value to be applied to at least one subsequent signal received by the receiving means. In this way, the predistorting means can adapt to changes in the operating conditions of the amplifier means.” 3:14-21.</p> <p>“Preferably, means are provided in the feedback path for separating the output of the amplifying means into a plurality of different signals. The predistorting means is preferably arranged to</p>

Claim No.	'204 Patent	Exemplary Evidence of Anticipation and/or Obviousness
		<p>compare each of the separated signals with the corresponding signals received from the input means and to determine if the at least one predistortion value needs to be altered.” 3:23-29.</p> <p>“Alternatively, the predistorting means is arranged to compare the composite signal from the amplifying means with a plurality of different signals to provide, if necessary, the at least one new predistortion value.” 3:30-33.</p> <p>“The amplifier means is preferably a nonlinear amplifier. The predistortion means is preferably arranged to compensate for the nonlinearity of the phase and/or amplitude of the output of the amplifier.” 3:45-58.</p> <p>“A digital to analogue converter may be provided for converting the plurality of signals to analogue form before said signals are amplified by said amplifier means.</p> <p>The transmitter is preferably incorporated in a base station or alternatively in a mobile station.</p> <p>According to a second aspect of the present invention, there is provided a multi carrier frequency transmission method comprising the steps of receiving a plurality of different digital signals to be transmitted, said different signals to be transmitted on different carrier frequencies; combining said plurality of different signals to provide a composite signal comprising the different signals at the respective carrier frequencies; and amplifying said composite signal, wherein the method further comprises the steps of: predistorting the plurality of different digital signals prior to amplification of the composite signal by the amplification means; and altering the predistortion applied to subsequent signals in dependence on the difference between said different signals and the amplified signal.” 3:49-67.</p> <p>“Reference will now be made to FIG. 4 which shows a first embodiment of the present invention. In particular, the transmit part 102 of the base station 100 is shown. The base station 100 is in a cellular system of the type shown in FIG. 1.” 4:30-34.</p> <p>“The transmit part 102 of the base station 100 comprises N channel encoders 104 where N is the number of different frequencies on which the base station 100 will transmit signals. Each channel encoder 104 receives the data to be transmitted on the particular frequency associated with the</p>

Claim No.	'204 Patent	Exemplary Evidence of Anticipation and/or Obviousness
		<p>given channel encoder 104. The data is placed in a suitable form for transmission. This may include digitising the data, encoding the data, interleaving the data and/or any other step required to be carried out. As mentioned hereinbefore, each channel is on a different frequency after the modulator. The signals output by the channel encoders 104 are in digital form and are at a baseband frequency. Coding, interleaving etc is performed on the digital baseband signals.” 4:35-36.</p> <p>“The output of each channel encoder 104 is input to a respective digital modulator 106. Each digital modulator 106 also receives two outputs from the adaptive predistorter 108. The first output from the predistorter 108 provides one or more amplitude coefficients which are used to predistort the signal which is output by the digital modulator to compensate for the non linearity of an amplifier 122 with respect to amplitude. The second output from the predistorter 108 provides one or more phase coefficients which are used to predistort the signal which is output by the modulator 106 to compensate for phase distortion provided by the amplifier 122. The amplifier 122 will be described in more detail hereinafter.” 4:48-60.</p> <p>“The predistortion to compensate for the phase and amplitude distortion introduced by the amplifier 122 can take place at the same time. The predistortion can be performed during or more preferably after the modulation has been carried out by the modulator 106.” 5:6-10.</p> <p>“The output of the second bandpass filter 120 is input to the power amplifier 122 which amplifies the received input. The output of the amplifier 122 is input to a third bandpass filter 124 which is arranged to filter out any signal components introduced by the amplifier 122 which fall outside the radio frequency band of the signals to be transmitted. The output of the third bandpass filter 124 is passed to an antenna 126 which transmits the signals to the terminals in the cell associated with the base station.” 5:41-49.</p> <p>“The adaptive predistorter 108 does not, as in the first embodiment, have outputs connected to the digital modulators 106. The output of the combiner 110 is connected to the input of the predistorter 108. The output of the predistorter 108 is connected to the input of the digital to analogue convertor. The predistorter 108 thus predistorts the multicarrier output of the combiner 110 and outputs a predistorted multicarrier signal. The feedback path is the same in the first and second embodiments and accordingly the predistorter 108 operates in a similar manner to that shown in the</p>

Claim No.	'204 Patent	Exemplary Evidence of Anticipation and/or Obviousness
		<p>first embodiment. However, phase correction is not applied and the amplitude correction is the same for all frequencies. This solution is simple but may not provide the required performance in all cases.” 7:39-52.</p> <p>“Reference will now be made to FIG. 8 which shows a second predistorter 108 b which can be used in the second embodiment shown in FIG. 5. This second predistorter 108 comprises n subtractors 208 each of which receives an output from a respective one of the digital modulators. Each subtractor 208 also receives a corresponding input from the channelizer 140 as in the first embodiment. Each subtractor 208 thus receives two modulated signals. The two signals received by each subtractor 208 are subtracted one from the other to generate a difference signal. This output difference signal is input to the adaption algorithm block 204 which is the same as discussed in relation to the first predistorter of FIG. 7. As with the first predistorter of FIG. 7, the adaption algorithm block 204 also receives an input from the microcontroller 142 with information concerning the frequency. The adaption algorithm block 204 provides amplitude coefficients on its output which are output to the look-up table 200. Unlike the embodiment shown in FIG. 7, the look-up table receives the multicarrier signal from the combiner 110 which defines an address in the look-up table. Accordingly, the multicarrier signal is modified in accordance with the amplitude values from the look-up table and output to the digital to analogue convertor 112.” 7:53-8:8.</p> <p>“Reference is now made to FIG. 10 which shows a possible construction of the channeliser 140. The channeliser comprises n blocks 220, with one block provided for each frequency. Each block of the channeliser 220 comprises an input for receiving the output of the analogue to digital converter 138 and a frequency control signal from the microcontroller 142. The output from the analogue to digital converter 138 is input to first and second multipliers 222 and 224. The first multiplier 222 produces the I or in-band, component of the input signal whilst the second multiplier 224 produces the Q, or quadrature-phase component of the input signal. Each of the multipliers 222 and 224 receives a frequency from the numerically controlled oscillator 226. The frequency of the oscillator 226 is controlled by the frequency control input. The output of the oscillator 226 is connected directly to one of the multipliers 222 whilst the output for the second multipliers 224 is connected to a phase shifter 228 which shifts the phase of the output signal from the oscillator 226</p>

Claim No.	'204 Patent	Exemplary Evidence of Anticipation and/or Obviousness
		<p>by 90°. The phase shifted output signal of the oscillator 226 is input to the second multipliers 224.” 8:9-28.</p> <p>“The output of each of the first and second multipliers 222 and 224 are connected to filters 230 and 232 which are arranged to filter out signal components introduced by the respective multipliers as well as other carriers within the multicarrier signal.” 8:29-33.</p> <p>“In the embodiments where the composite signal is predistorted, the combiner output consists of amplitude words, the correction occurring by adjusting the magnitude of the words. Nonlinearities in the amplifier output could be compensated by correcting the magnitude of the combiner output words with an inverse function. The correction may thus be dependent on the particular combiner output. This might occur by indexing a look-up table with the combiner output word and outputting the respective contents to the digital to analogue converter.” 9:18-27.</p> <p style="text-align: center;">Fig.4.</p>

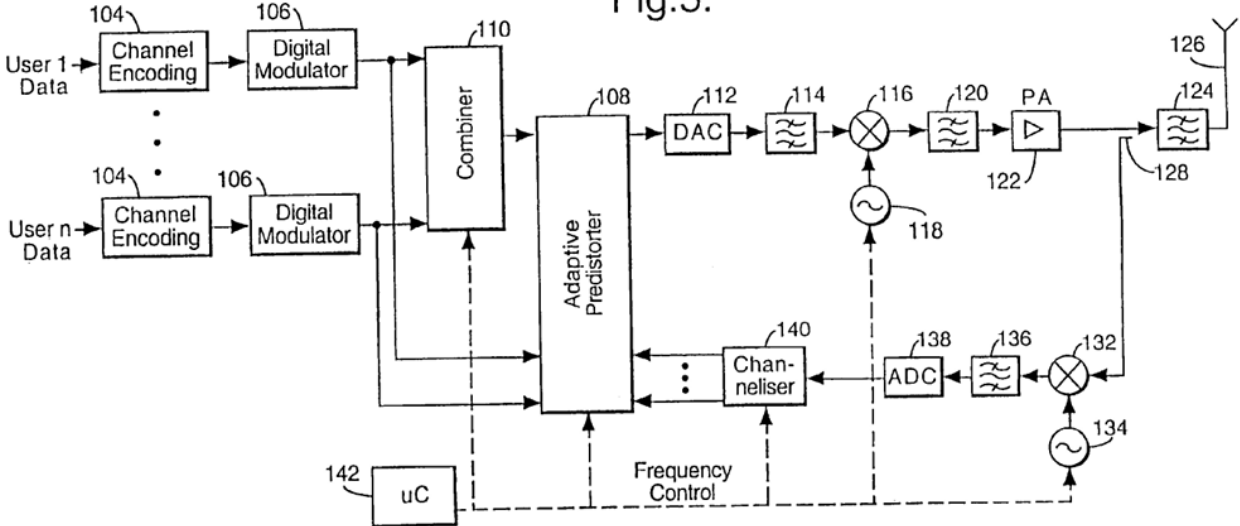
Claim No.	'204 Patent	Exemplary Evidence of Anticipation and/or Obviousness
		<p data-bbox="837 188 922 217">Fig. 4.</p>  <p data-bbox="1464 271 1572 316">Fig. 5.</p> <p data-bbox="837 858 922 887">Fig. 5.</p>

Claim No.	'204 Patent	Exemplary Evidence of Anticipation and/or Obviousness
-----------	-------------	---

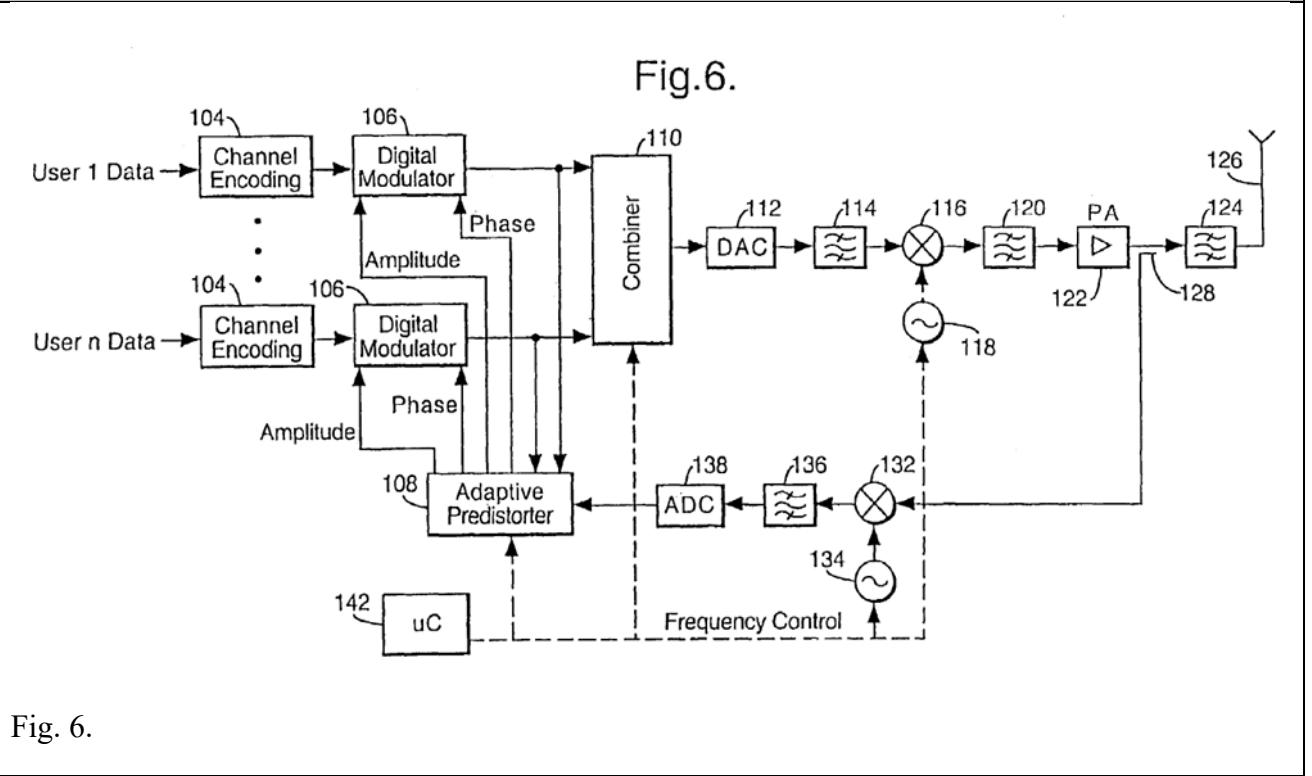

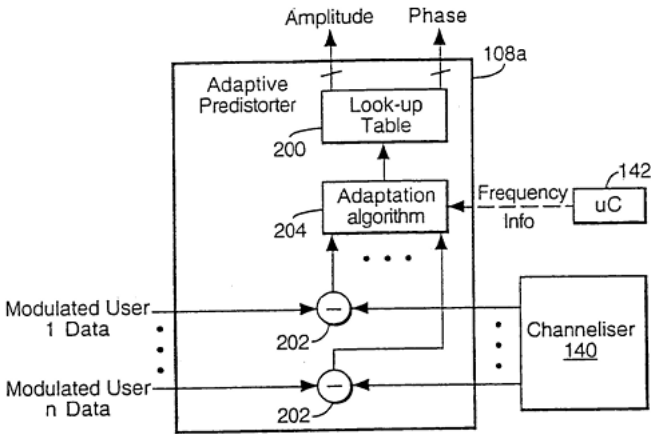
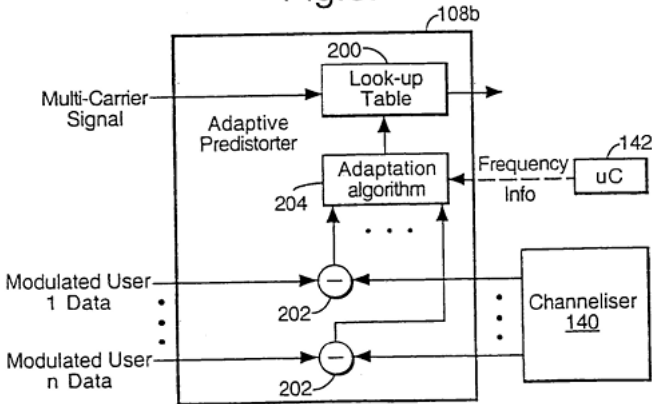
Claim No.	'204 Patent	Exemplary Evidence of Anticipation and/or Obviousness
		<p data-bbox="1144 188 1245 225">Fig.7.</p>  <p data-bbox="1151 788 1252 825">Fig.8.</p>  <p data-bbox="837 1286 1016 1323">Figs. 7 and 8.</p>

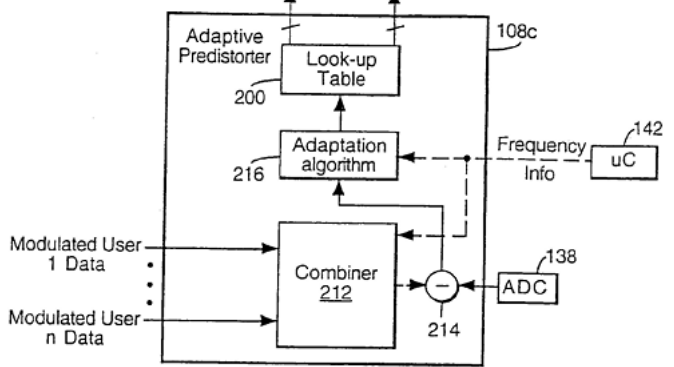
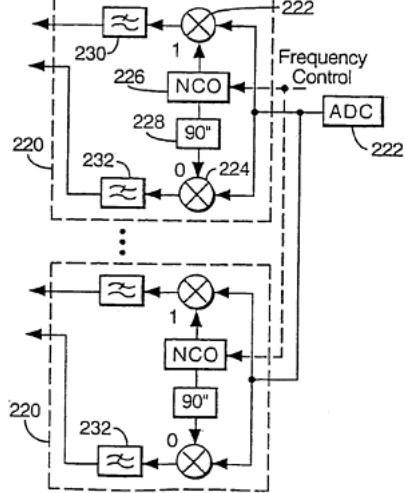
Claim No.	'204 Patent	Exemplary Evidence of Anticipation and/or Obviousness
		<p data-bbox="996 183 1276 223">Fig.9. Amplitude Phase</p>  <p data-bbox="974 678 1120 718">Fig.10.</p> <p data-bbox="974 718 1344 750">Principle of an NCO-Based Channeliser</p>  <p data-bbox="840 1284 985 1324">Figs. 9-10.</p>

Claim No.	'204 Patent	Exemplary Evidence of Anticipation and/or Obviousness
3[b]	<p>wherein the signal observation feedback loop includes an analyzing and modeling stage directly connected to each of the plurality of outputs of said digital multi-band predistortion block for receiving the respective predistorted signals and for using said received predistorted signals in controlling said digital multi-band predistortion block.</p>	<p>Posti discloses and/or renders obvious the transmitter of claim 2, wherein the signal observation feedback loop includes an analyzing and modeling stage directly connected to each of the plurality of outputs of said digital multi-band predistortion block for receiving the respective predistorted signals and for using said received predistorted signals in controlling said digital multi-band predistortion block..</p> <p><i>See</i> claim 2, <i>supra</i>, which is incorporated by reference herein.</p> <p><i>See, e.g.,</i></p> <p>“A multi frequency carrier transmitter comprises input means for receiving a plurality of different digital signals to be transmitted. The different signals are to be transmitted on different carrier frequencies. Amplifier means receive a composite signal comprising the different signals at the respective carrier frequencies and amplify the composite signal. Predistortion means predistort the plurality of digital signals prior to amplification of the composite signal by the amplification means. The predistortion provided by the predistortion means is subsequently altered in dependence on the difference between the input signals and the output at the amplifier means.” Abstract.</p> <p>“The present invention relates to a transmitter and a method of transmitting and in particular, but not exclusively, for use in a telecommunications network.”</p> <p>“The output of each transmit path 14–14' is connected to the input of a combiner 22 which combines the signals from each path 14–14' to provide a multicarrier signal. The output of the combiner 22 is connected to an antenna 24 which transmits the multicarrier signal containing each of the N different channels to the terminals in the cell served by the base station.” 1:53-59.</p> <p>“According to one aspect of the present invention, there is provided a multi frequency carrier transmitter comprising input means for receiving a plurality of different digital signals to be transmitted, said different signals to be transmitted on different carrier frequencies; amplifier means for receiving a composite signal comprising said different signals at the respective carrier frequencies and amplifying said composite signal; and predistortion means for predistorting said plurality of digital signals prior to amplification of the composite signal by said amplification</p>

Claim No.	'204 Patent	Exemplary Evidence of Anticipation and/or Obviousness
		<p>means, said predistortion provided by said predistortion means being subsequently altered in dependence on the difference between said input signals and the output at said amplifier means.” 2:43-55.</p> <p>“Accordingly, embodiments of the present invention provide a multi carrier transmitter which is able to deal with the problems of nonlinearity by using predistortion. The predistortion can be implemented more simply than the feedback method discussed in the prior art.” 2:55-60.</p> <p>“The output of the second bandpass filter 120 is input to the power amplifier 122 which amplifies the received input. The output of the amplifier 122 is input to a third bandpass filter 124 which is arranged to filter out any signal components introduced by the amplifier 122 which fall outside the radio frequency band of the signals to be transmitted. The output of the third bandpass filter 124 is passed to an antenna 126 which transmits the signals to the terminals in the cell associated with the base station.” 5:41-49.</p> <p>“The input means are preferably arranged to separately receive each of the different signals. Combiner means are preferably provided between the input means and the amplifier means for combining said plurality of different signals to provide a composite signal. This may be the composite signal input to the amplifier means or may be a composite signal at a lower, intermediate frequency. In the latter case, that composite signal at a lower frequency would be upconverted to provide the composite signal input to the amplifier means.” 2:61-3:3.</p> <p>“A feedback path may be arranged between the amplifying means and the predistorting means. Preferably, the predistorting means is arranged to compare the output from the amplifying means from the feedback path with the signals received by the receiving means and to provide, if necessary, at least one new predistortion value to be applied to at least one subsequent signal received by the receiving means. In this way, the predistorting means can adapt to changes in the operating conditions of the amplifier means.” 3:14-21.</p> <p>“Preferably, means are provided in the feedback path for separating the output of the amplifying means into a plurality of different signals. The predistorting means is preferably arranged to</p>

Claim No.	'204 Patent	Exemplary Evidence of Anticipation and/or Obviousness
		<p>compare each of the separated signals with the corresponding signals received from the input means and to determine if the at least one predistortion value needs to be altered.” 3:23-29.</p> <p>“Alternatively, the predistorting means is arranged to compare the composite signal from the amplifying means with a plurality of different signals to provide, if necessary, the at least one new predistortion value.” 3:30-33.</p> <p>“The amplifier means is preferably a nonlinear amplifier. The predistortion means is preferably arranged to compensate for the nonlinearity of the phase and/or amplitude of the output of the amplifier.” 3:45-58.</p> <p>“A digital to analogue converter may be provided for converting the plurality of signals to analogue form before said signals are amplified by said amplifier means.</p> <p>The transmitter is preferably incorporated in a base station or alternatively in a mobile station.</p> <p>According to a second aspect of the present invention, there is provided a multi carrier frequency transmission method comprising the steps of receiving a plurality of different digital signals to be transmitted, said different signals to be transmitted on different carrier frequencies; combining said plurality of different signals to provide a composite signal comprising the different signals at the respective carrier frequencies; and amplifying said composite signal, wherein the method further comprises the steps of: predistorting the plurality of different digital signals prior to amplification of the composite signal by the amplification means; and altering the predistortion applied to subsequent signals in dependence on the difference between said different signals and the amplified signal.” 3:49-67.</p> <p>“Reference will now be made to FIG. 4 which shows a first embodiment of the present invention. In particular, the transmit part 102 of the base station 100 is shown. The base station 100 is in a cellular system of the type shown in FIG. 1.” 4:30-34.</p> <p>“The transmit part 102 of the base station 100 comprises N channel encoders 104 where N is the number of different frequencies on which the base station 100 will transmit signals. Each channel encoder 104 receives the data to be transmitted on the particular frequency associated with the</p>

Claim No.	'204 Patent	Exemplary Evidence of Anticipation and/or Obviousness
		<p>given channel encoder 104. The data is placed in a suitable form for transmission. This may include digitising the data, encoding the data, interleaving the data and/or any other step required to be carried out. As mentioned hereinbefore, each channel is on a different frequency after the modulator. The signals output by the channel encoders 104 are in digital form and are at a baseband frequency. Coding, interleaving etc is performed on the digital baseband signals.” 4:35-36.</p> <p>“The output of each channel encoder 104 is input to a respective digital modulator 106. Each digital modulator 106 also receives two outputs from the adaptive predistorter 108. The first output from the predistorter 108 provides one or more amplitude coefficients which are used to predistort the signal which is output by the digital modulator to compensate for the non linearity of an amplifier 122 with respect to amplitude. The second output from the predistorter 108 provides one or more phase coefficients which are used to predistort the signal which is output by the modulator 106 to compensate for phase distortion provided by the amplifier 122. The amplifier 122 will be described in more detail hereinafter.” 4:48-60.</p> <p>“The predistortion to compensate for the phase and amplitude distortion introduced by the amplifier 122 can take place at the same time. The predistortion can be performed during or more preferably after the modulation has been carried out by the modulator 106.” 5:6-10.</p> <p>“The output of the second bandpass filter 120 is input to the power amplifier 122 which amplifies the received input. The output of the amplifier 122 is input to a third bandpass filter 124 which is arranged to filter out any signal components introduced by the amplifier 122 which fall outside the radio frequency band of the signals to be transmitted. The output of the third bandpass filter 124 is passed to an antenna 126 which transmits the signals to the terminals in the cell associated with the base station.” 5:41-49.</p> <p>“The adaptive predistorter 108 does not, as in the first embodiment, have outputs connected to the digital modulators 106. The output of the combiner 110 is connected to the input of the predistorter 108. The output of the predistorter 108 is connected to the input of the digital to analogue convertor. The predistorter 108 thus predistorts the multicarrier output of the combiner 110 and outputs a predistorted multicarrier signal. The feedback path is the same in the first and second embodiments and accordingly the predistorter 108 operates in a similar manner to that shown in the</p>

Claim No.	'204 Patent	Exemplary Evidence of Anticipation and/or Obviousness
		<p>first embodiment. However, phase correction is not applied and the amplitude correction is the same for all frequencies. This solution is simple but may not provide the required performance in all cases.” 7:39-52.</p> <p>“Reference will now be made to FIG. 8 which shows a second predistorter 108 b which can be used in the second embodiment shown in FIG. 5. This second predistorter 108 comprises n subtractors 208 each of which receives an output from a respective one of the digital modulators. Each subtractor 208 also receives a corresponding input from the channelizer 140 as in the first embodiment. Each subtractor 208 thus receives two modulated signals. The two signals received by each subtractor 208 are subtracted one from the other to generate a difference signal. This output difference signal is input to the adaption algorithm block 204 which is the same as discussed in relation to the first predistorter of FIG. 7. As with the first predistorter of FIG. 7, the adaption algorithm block 204 also receives an input from the microcontroller 142 with information concerning the frequency. The adaption algorithm block 204 provides amplitude coefficients on its output which are output to the look-up table 200. Unlike the embodiment shown in FIG. 7, the look-up table receives the multicarrier signal from the combiner 110 which defines an address in the look-up table. Accordingly, the multicarrier signal is modified in accordance with the amplitude values from the look-up table and output to the digital to analogue convertor 112.” 7:53-8:8.</p> <p>“Reference is now made to FIG. 10 which shows a possible construction of the channeliser 140. The channeliser comprises n blocks 220, with one block provided for each frequency. Each block of the channeliser 220 comprises an input for receiving the output of the analogue to digital converter 138 and a frequency control signal from the microcontroller 142. The output from the analogue to digital converter 138 is input to first and second multipliers 222 and 224. The first multiplier 222 produces the I or in-band, component of the input signal whilst the second multiplier 224 produces the Q, or quadrature-phase component of the input signal. Each of the multipliers 222 and 224 receives a frequency from the numerically controlled oscillator 226. The frequency of the oscillator 226 is controlled by the frequency control input. The output of the oscillator 226 is connected directly to one of the multipliers 222 whilst the output for the second multipliers 224 is connected to a phase shifter 228 which shifts the phase of the output signal from the oscillator 226</p>

Claim No.	'204 Patent	Exemplary Evidence of Anticipation and/or Obviousness
		<p>by 90°. The phase shifted output signal of the oscillator 226 is input to the second multipliers 224.” 8:9-28.</p> <p>“The output of each of the first and second multipliers 222 and 224 are connected to filters 230 and 232 which are arranged to filter out signal components introduced by the respective multipliers as well as other carriers within the multicarrier signal.” 8:29-33.</p> <p>“In the embodiments where the composite signal is predistorted, the combiner output consists of amplitude words, the correction occurring by adjusting the magnitude of the words. Nonlinearities in the amplifier output could be compensated by correcting the magnitude of the combiner output words with an inverse function. The correction may thus be dependent on the particular combiner output. This might occur by indexing a look-up table with the combiner output word and outputting the respective contents to the digital to analogue converter.” 9:18-27.</p> <p style="text-align: center;">Fig.4.</p>

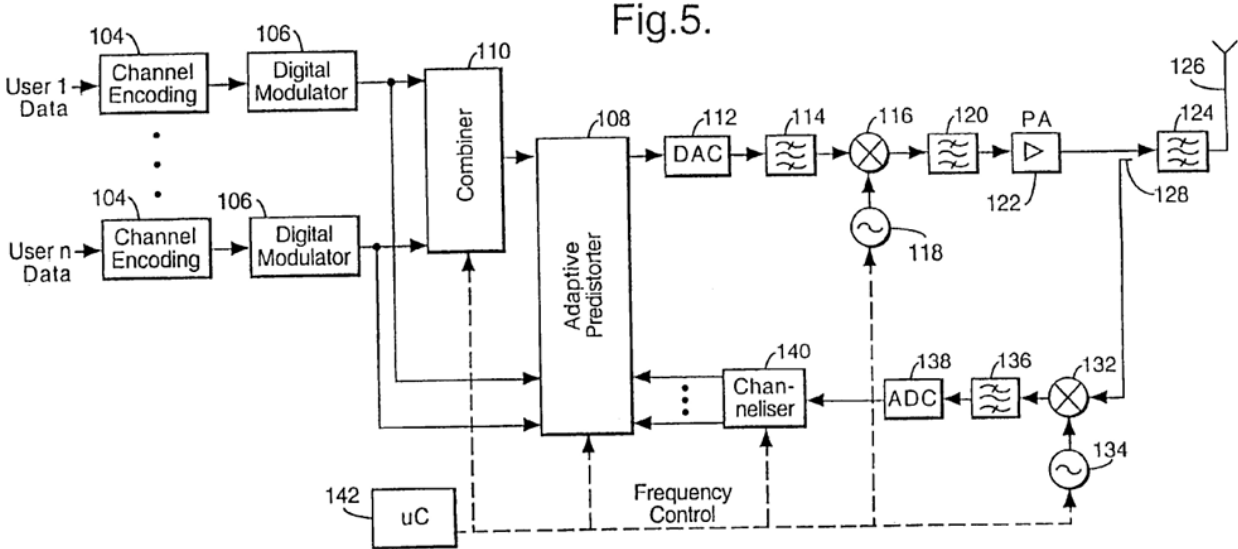
Claim No.	'204 Patent	Exemplary Evidence of Anticipation and/or Obviousness
		<p data-bbox="837 188 922 217">Fig. 4.</p>  <p data-bbox="1464 271 1572 316">Fig.5.</p> <p data-bbox="837 858 922 887">Fig. 5.</p>

Claim No.	'204 Patent	Exemplary Evidence of Anticipation and/or Obviousness
-----------	-------------	---

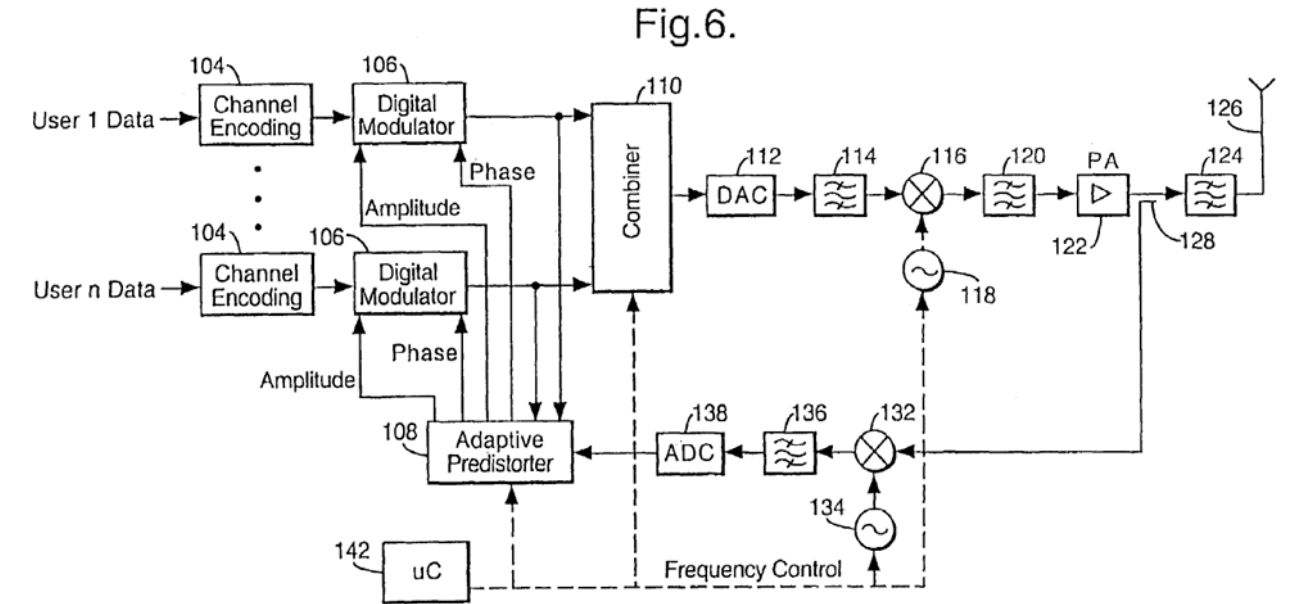
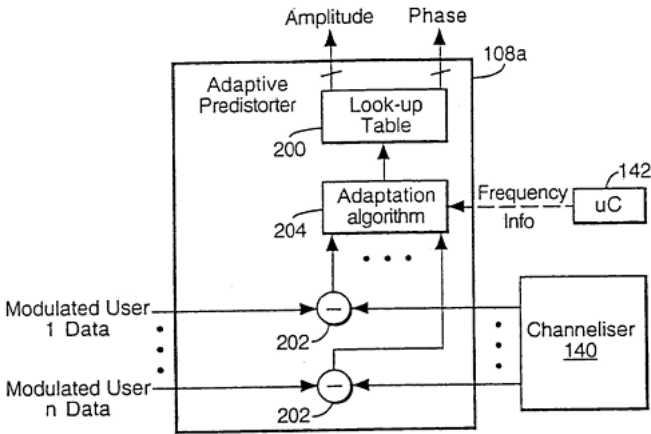
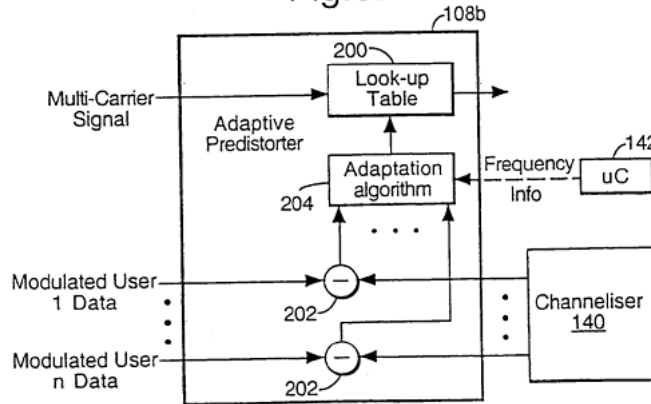
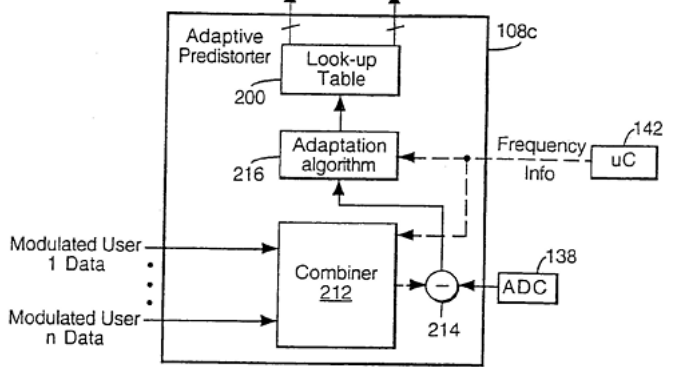
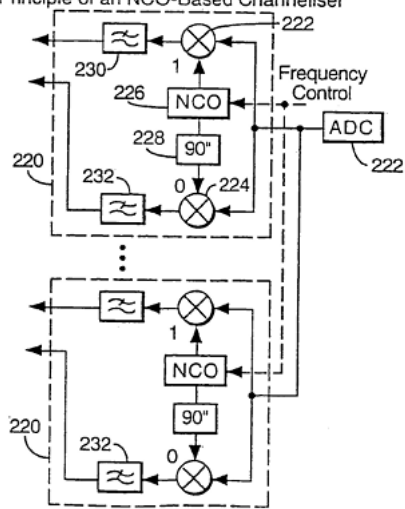

Fig. 6.

Claim No.	'204 Patent	Exemplary Evidence of Anticipation and/or Obviousness
		<p data-bbox="1144 188 1245 225">Fig.7.</p>  <p data-bbox="1144 788 1245 825">Fig.8.</p>  <p data-bbox="837 1286 1014 1323">Figs. 7 and 8.</p>

Claim No.	'204 Patent	Exemplary Evidence of Anticipation and/or Obviousness
		<p data-bbox="996 183 1276 223">Fig.9. Amplitude Phase</p>  <p data-bbox="974 678 1332 718">Fig.10. Principle of an NCO-Based Channeliser</p>  <p data-bbox="840 1284 985 1324">Figs. 9-10.</p>

Claim No.	'204 Patent	Exemplary Evidence of Anticipation and/or Obviousness
4[a]	<p>The transmitter of claim 3, wherein said analyzing and modeling stage further comprises:</p> <p>a plurality of outputs connected to and for updating the parameters of said digital baseband signal predistorter block;</p>	<p>Posti discloses and/or renders obvious the transmitter of claim 3, wherein said analyzing and modeling stage further comprises: a plurality of outputs connected to and for updating the parameters of said digital baseband signal predistorter block.</p> <p><i>See</i> claim 3, <i>supra</i>, which is incorporated by reference herein.</p> <p><i>See, e.g.,</i></p> <p>“A multi frequency carrier transmitter comprises input means for receiving a plurality of different digital signals to be transmitted. The different signals are to be transmitted on different carrier frequencies. Amplifier means receive a composite signal comprising the different signals at the respective carrier frequencies and amplify the composite signal. Predistortion means predistort the plurality of digital signals prior to amplification of the composite signal by the amplification means. The predistortion provided by the predistortion means is subsequently altered in dependence on the difference between the input signals and the output at the amplifier means.” Abstract.</p> <p>“The present invention relates to a transmitter and a method of transmitting and in particular, but not exclusively, for use in a telecommunications network.”</p> <p>“The output of each transmit path 14–14' is connected to the input of a combiner 22 which combines the signals from each path 14–14' to provide a multicarrier signal. The output of the combiner 22 is connected to an antenna 24 which transmits the multicarrier signal containing each of the N different channels to the terminals in the cell served by the base station.” 1:53-59.</p> <p>“According to one aspect of the present invention, there is provided a multi frequency carrier transmitter comprising input means for receiving a plurality of different digital signals to be transmitted, said different signals to be transmitted on different carrier frequencies; amplifier means for receiving a composite signal comprising said different signals at the respective carrier frequencies and amplifying said composite signal; and predistortion means for predistorting said plurality of digital signals prior to amplification of the composite signal by said amplification means, said predistortion provided by said predistortion means being subsequently altered in</p>

Claim No.	'204 Patent	Exemplary Evidence of Anticipation and/or Obviousness
		<p>dependence on the difference between said input signals and the output at said amplifier means.” 2:43-55.</p> <p>“Accordingly, embodiments of the present invention provide a multi carrier transmitter which is able to deal with the problems of nonlinearity by using predistortion. The predistortion can be implemented more simply than the feedback method discussed in the prior art.” 2:55-60.</p> <p>“The output of the second bandpass filter 120 is input to the power amplifier 122 which amplifies the received input. The output of the amplifier 122 is input to a third bandpass filter 124 which is arranged to filter out any signal components introduced by the amplifier 122 which fall outside the radio frequency band of the signals to be transmitted. The output of the third bandpass filter 124 is passed to an antenna 126 which transmits the signals to the terminals in the cell associated with the base station.” 5:41-49.</p> <p>“The input means are preferably arranged to separately receive each of the different signals. Combiner means are preferably provided between the input means and the amplifier means for combining said plurality of different signals to provide a composite signal. This may be the composite signal input to the amplifier means or may be a composite signal at a lower, intermediate frequency. In the latter case, that composite signal at a lower frequency would be upconverted to provide the composite signal input to the amplifier means.” 2:61-3:3.</p> <p>“A feedback path may be arranged between the amplifying means and the predistorting means. Preferably, the predistorting means is arranged to compare the output from the amplifying means from the feedback path with the signals received by the receiving means and to provide, if necessary, at least one new predistortion value to be applied to at least one subsequent signal received by the receiving means. In this way, the predistorting means can adapt to changes in the operating conditions of the amplifier means.” 3:14-21.</p> <p>“Preferably, means are provided in the feedback path for separating the output of the amplifying means into a plurality of different signals. The predistorting means is preferably arranged to compare each of the separated signals with the corresponding signals received from the input means and to determine if the at least one predistortion value needs to be altered.” 3:23-29.</p>

Claim No.	'204 Patent	Exemplary Evidence of Anticipation and/or Obviousness
		<p>“Alternatively, the predistorting means is arranged to compare the composite signal from the amplifying means with a plurality of different signals to provide, if necessary, the at least one new predistortion value.” 3:30-33.</p> <p>“The amplifier means is preferably a nonlinear amplifier. The predistortion means is preferably arranged to compensate for the nonlinearity of the phase and/or amplitude of the output of the amplifier.” 3:45-58.</p> <p>“A digital to analogue converter may be provided for converting the plurality of signals to analogue form before said signals are amplified by said amplifier means.</p> <p>The transmitter is preferably incorporated in a base station or alternatively in a mobile station.</p> <p>According to a second aspect of the present invention, there is provided a multi carrier frequency transmission method comprising the steps of receiving a plurality of different digital signals to be transmitted, said different signals to be transmitted on different carrier frequencies; combining said plurality of different signals to provide a composite signal comprising the different signals at the respective carrier frequencies; and amplifying said composite signal, wherein the method further comprises the steps of: predistorting the plurality of different digital signals prior to amplification of the composite signal by the amplification means; and altering the predistortion applied to subsequent signals in dependence on the difference between said different signals and the amplified signal.” 3:49-67.</p> <p>“Reference will now be made to FIG. 4 which shows a first embodiment of the present invention. In particular, the transmit part 102 of the base station 100 is shown. The base station 100 is in a cellular system of the type shown in FIG. 1.” 4:30-34.</p> <p>“The transmit part 102 of the base station 100 comprises N channel encoders 104 where N is the number of different frequencies on which the base station 100 will transmit signals. Each channel encoder 104 receives the data to be transmitted on the particular frequency associated with the given channel encoder 104. The data is placed in a suitable form for transmission. This may include digitising the data, encoding the data, interleaving the data and/or any other step required to be carried out. As mentioned hereinbefore, each channel is on a different frequency after the</p>

Claim No.	'204 Patent	Exemplary Evidence of Anticipation and/or Obviousness
		<p>modulator. The signals output by the channel encoders 104 are in digital form and are at a baseband frequency. Coding, interleaving etc is performed on the digital baseband signals.” 4:35-36.</p> <p>“The output of each channel encoder 104 is input to a respective digital modulator 106. Each digital modulator 106 also receives two outputs from the adaptive predistorter 108. The first output from the predistorter 108 provides one or more amplitude coefficients which are used to predistort the signal which is output by the digital modulator to compensate for the non linearity of an amplifier 122 with respect to amplitude. The second output from the predistorter 108 provides one or more phase coefficients which are used to predistort the signal which is output by the modulator 106 to compensate for phase distortion provided by the amplifier 122. The amplifier 122 will be described in more detail hereinafter.” 4:48-60.</p> <p>“The predistortion to compensate for the phase and amplitude distortion introduced by the amplifier 122 can take place at the same time. The predistortion can be performed during or more preferably after the modulation has been carried out by the modulator 106.” 5:6-10.</p> <p>“The output of the second bandpass filter 120 is input to the power amplifier 122 which amplifies the received input. The output of the amplifier 122 is input to a third bandpass filter 124 which is arranged to filter out any signal components introduced by the amplifier 122 which fall outside the radio frequency band of the signals to be transmitted. The output of the third bandpass filter 124 is passed to an antenna 126 which transmits the signals to the terminals in the cell associated with the base station.” 5:41-49.</p> <p>“The adaptive predistorter 108 does not, as in the first embodiment, have outputs connected to the digital modulators 106. The output of the combiner 110 is connected to the input of the predistorter 108. The output of the predistorter 108 is connected to the input of the digital to analogue convertor. The predistorter 108 thus predistorts the multicarrier output of the combiner 110 and outputs a predistorted multicarrier signal. The feedback path is the same in the first and second embodiments and accordingly the predistorter 108 operates in a similar manner to that shown in the first embodiment. However, phase correction is not applied and the amplitude correction is the</p>

Claim No.	'204 Patent	Exemplary Evidence of Anticipation and/or Obviousness
		<p>same for all frequencies. This solution is simple but may not provide the required performance in all cases.” 7:39-52.</p> <p>“Reference will now be made to FIG. 8 which shows a second predistorter 108 b which can be used in the second embodiment shown in FIG. 5. This second predistorter 108 comprises n subtractors 208 each of which receives an output from a respective one of the digital modulators. Each subtractor 208 also receives a corresponding input from the channelizer 140 as in the first embodiment. Each subtractor 208 thus receives two modulated signals. The two signals received by each subtractor 208 are subtracted one from the other to generate a difference signal. This output difference signal is input to the adaption algorithm block 204 which is the same as discussed in relation to the first predistorter of FIG. 7. As with the first predistorter of FIG. 7, the adaption algorithm block 204 also receives an input from the microcontroller 142 with information concerning the frequency. The adaption algorithm block 204 provides amplitude coefficients on its output which are output to the look-up table 200. Unlike the embodiment shown in FIG. 7, the look-up table receives the multicarrier signal from the combiner 110 which defines an address in the look-up table. Accordingly, the multicarrier signal is modified in accordance with the amplitude values from the look-up table and output to the digital to analogue convertor 112.” 7:53-8:8.</p> <p>“Reference is now made to FIG. 10 which shows a possible construction of the channeliser 140. The channeliser comprises n blocks 220, with one block provided for each frequency. Each block of the channeliser 220 comprises an input for receiving the output of the analogue to digital converter 138 and a frequency control signal from the microcontroller 142. The output from the analogue to digital converter 138 is input to first and second multipliers 222 and 224. The first multiplier 222 produces the I or in-band, component of the input signal whilst the second multiplier 224 produces the Q, or quadrature-phase component of the input signal. Each of the multipliers 222 and 224 receives a frequency from the numerically controlled oscillator 226. The frequency of the oscillator 226 is controlled by the frequency control input. The output of the oscillator 226 is connected directly to one of the multipliers 222 whilst the output for the second multipliers 224 is connected to a phase shifter 228 which shifts the phase of the output signal from the oscillator 226 by 90°. The phase shifted output signal of the oscillator 226 is input to the second multipliers 224.” 8:9-28.</p>

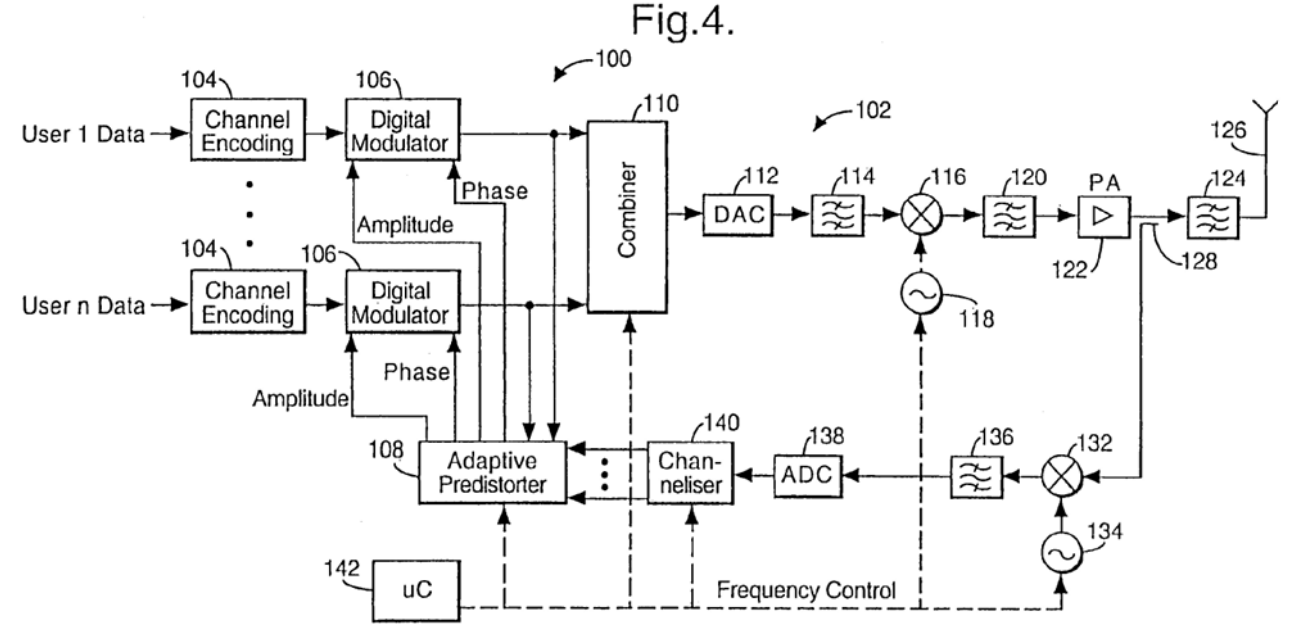
Claim No.	'204 Patent	Exemplary Evidence of Anticipation and/or Obviousness
		<p data-bbox="837 188 2123 292">“The output of each of the first and second multipliers 222 and 224 are connected to filters 230 and 232 which are arranged to filter out signal components introduced by the respective multipliers as well as other carriers within the multicarrier signal.” 8:29-33.</p> <p data-bbox="837 331 2123 547">“In the embodiments where the composite signal is predistorted, the combiner output consists of amplitude words, the correction occurring by adjusting the magnitude of the words. Nonlinearities in the amplifier output could be compensated by correcting the magnitude of the combiner output words with an inverse function. The correction may thus be dependent on the particular combiner output. This might occur by indexing a look-up table with the combiner output word and outputting the respective contents to the digital to analogue converter.” 9:18-27.</p> <div data-bbox="837 592 2123 1220"> <p data-bbox="1464 592 1570 635">Fig.4.</p>  </div> <p data-bbox="837 1265 920 1297">Fig. 4.</p>

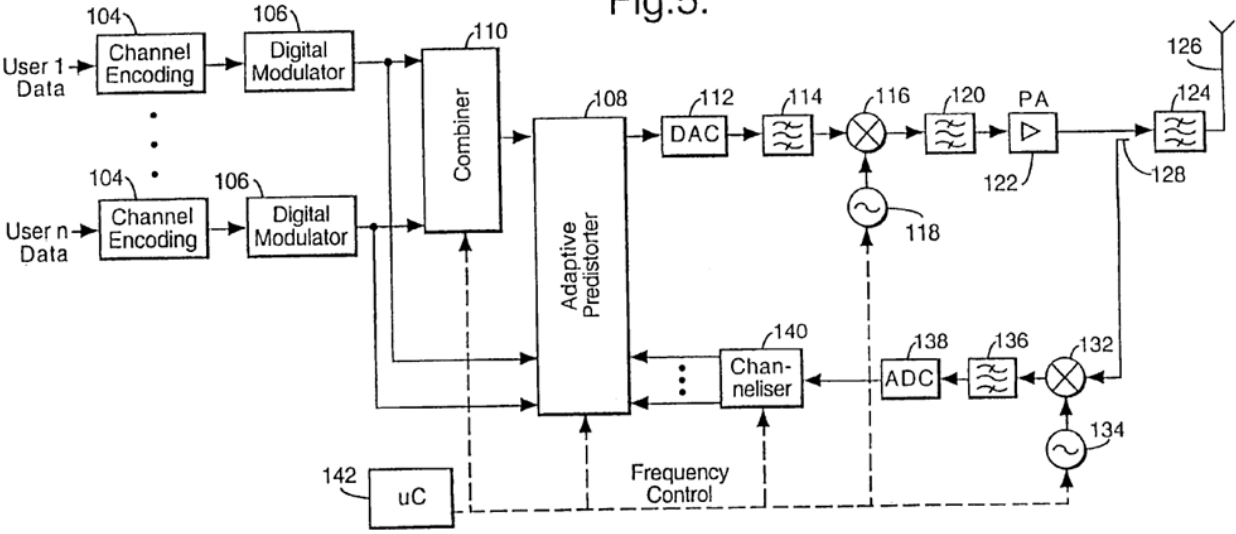
Claim No.	'204 Patent	Exemplary Evidence of Anticipation and/or Obviousness
		<p style="text-align: center;">Fig.5.</p>  <p style="text-align: center;">Fig. 5.</p>

Claim No.	'204 Patent	Exemplary Evidence of Anticipation and/or Obviousness
-----------	-------------	---

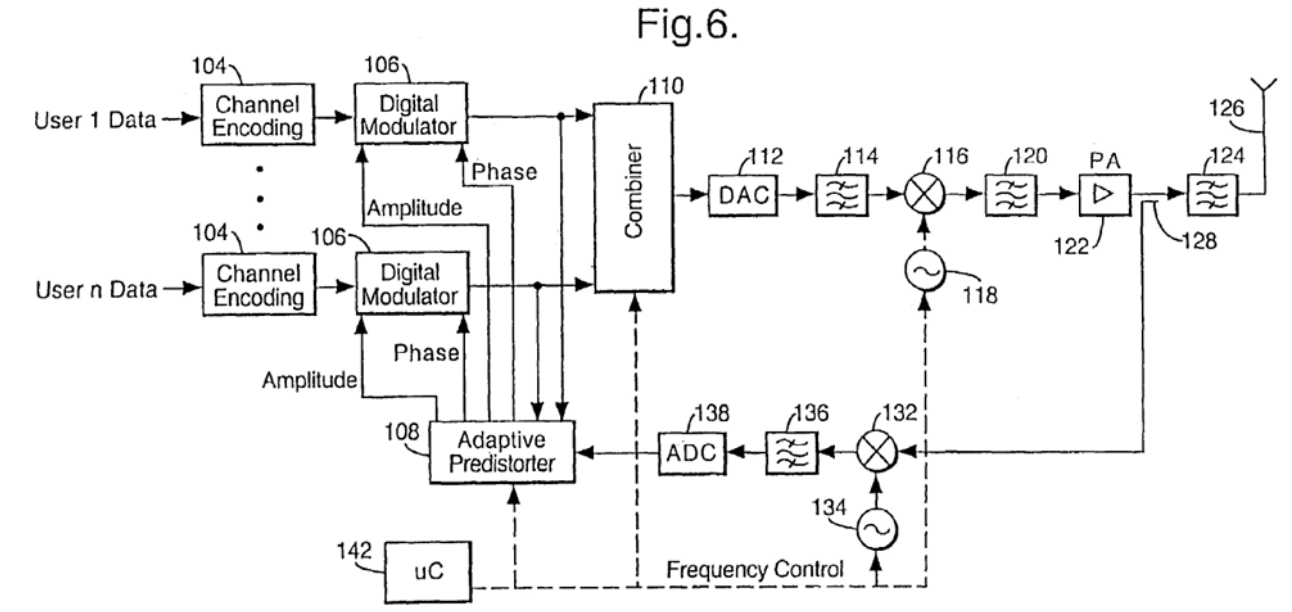
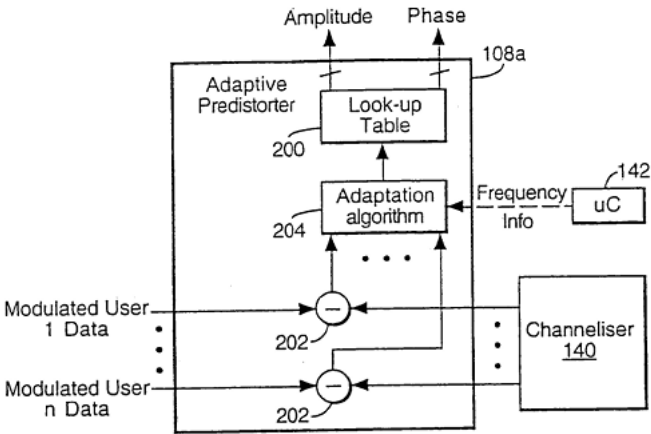
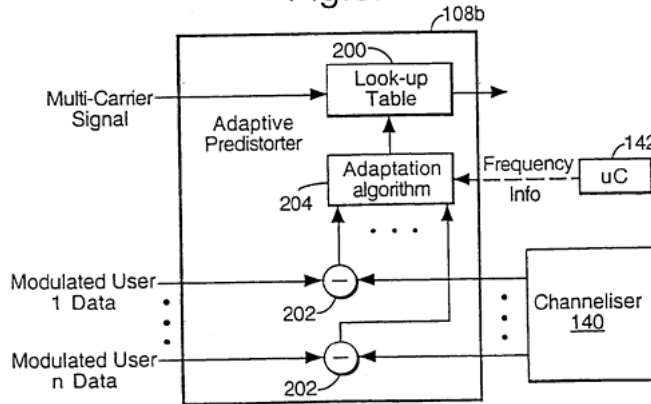
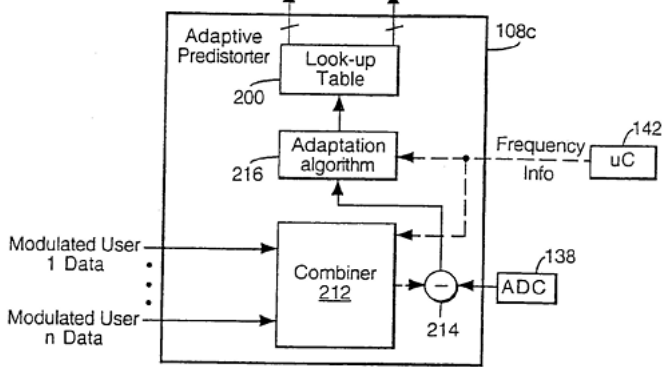
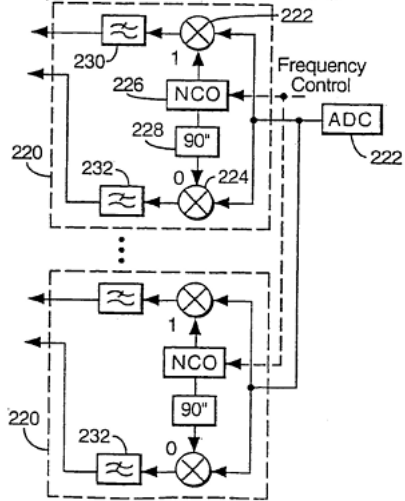

Fig. 6.

Claim No.	'204 Patent	Exemplary Evidence of Anticipation and/or Obviousness
		<p data-bbox="1144 188 1245 225">Fig.7.</p>  <p data-bbox="1144 788 1245 825">Fig.8.</p>  <p data-bbox="837 1286 1010 1323">Figs. 7 and 8.</p>

Claim No.	'204 Patent	Exemplary Evidence of Anticipation and/or Obviousness
		<p data-bbox="996 183 1276 223">Fig.9. Amplitude Phase</p>  <p data-bbox="974 678 1120 718">Fig.10.</p> <p data-bbox="974 718 1332 742">Principle of an NCO-Based Channeliser</p>  <p data-bbox="840 1284 985 1324">Figs. 9-10.</p>

Claim No.	'204 Patent	Exemplary Evidence of Anticipation and/or Obviousness
4[b]	a plurality of inputs connected to said outputs of said signal observation feedback loop.	<p>Posti discloses and/or renders obvious the transmitter of claim 3, wherein said analyzing and modeling stage further comprises: a plurality of inputs connected to said outputs of said signal observation feedback loop.</p> <p><i>See</i> claim 3, <i>supra</i>, which is incorporated by reference herein.</p> <p><i>See, e.g.,</i></p> <p>“A multi frequency carrier transmitter comprises input means for receiving a plurality of different digital signals to be transmitted. The different signals are to be transmitted on different carrier frequencies. Amplifier means receive a composite signal comprising the different signals at the respective carrier frequencies and amplify the composite signal. Predistortion means predistort the plurality of digital signals prior to amplification of the composite signal by the amplification means. The predistortion provided by the predistortion means is subsequently altered in dependence on the difference between the input signals and the output at the amplifier means.” Abstract.</p> <p>“The present invention relates to a transmitter and a method of transmitting and in particular, but not exclusively, for use in a telecommunications network.”</p> <p>“The output of each transmit path 14–14' is connected to the input of a combiner 22 which combines the signals from each path 14–14' to provide a multicarrier signal. The output of the combiner 22 is connected to an antenna 24 which transmits the multicarrier signal containing each of the N different channels to the terminals in the cell served by the base station.” 1:53-59.</p> <p>“According to one aspect of the present invention, there is provided a multi frequency carrier transmitter comprising input means for receiving a plurality of different digital signals to be transmitted, said different signals to be transmitted on different carrier frequencies; amplifier means for receiving a composite signal comprising said different signals at the respective carrier frequencies and amplifying said composite signal; and predistortion means for predistorting said plurality of digital signals prior to amplification of the composite signal by said amplification means, said predistortion provided by said predistortion means being subsequently altered in</p>

Claim No.	'204 Patent	Exemplary Evidence of Anticipation and/or Obviousness
		<p>dependence on the difference between said input signals and the output at said amplifier means.” 2:43-55.</p> <p>“Accordingly, embodiments of the present invention provide a multi carrier transmitter which is able to deal with the problems of nonlinearity by using predistortion. The predistortion can be implemented more simply than the feedback method discussed in the prior art.” 2:55-60.</p> <p>“The output of the second bandpass filter 120 is input to the power amplifier 122 which amplifies the received input. The output of the amplifier 122 is input to a third bandpass filter 124 which is arranged to filter out any signal components introduced by the amplifier 122 which fall outside the radio frequency band of the signals to be transmitted. The output of the third bandpass filter 124 is passed to an antenna 126 which transmits the signals to the terminals in the cell associated with the base station.” 5:41-49.</p> <p>“The input means are preferably arranged to separately receive each of the different signals. Combiner means are preferably provided between the input means and the amplifier means for combining said plurality of different signals to provide a composite signal. This may be the composite signal input to the amplifier means or may be a composite signal at a lower, intermediate frequency. In the latter case, that composite signal at a lower frequency would be upconverted to provide the composite signal input to the amplifier means.” 2:61-3:3.</p> <p>“A feedback path may be arranged between the amplifying means and the predistorting means. Preferably, the predistorting means is arranged to compare the output from the amplifying means from the feedback path with the signals received by the receiving means and to provide, if necessary, at least one new predistortion value to be applied to at least one subsequent signal received by the receiving means. In this way, the predistorting means can adapt to changes in the operating conditions of the amplifier means.” 3:14-21.</p> <p>“Preferably, means are provided in the feedback path for separating the output of the amplifying means into a plurality of different signals. The predistorting means is preferably arranged to compare each of the separated signals with the corresponding signals received from the input means and to determine if the at least one predistortion value needs to be altered.” 3:23-29.</p>

Claim No.	'204 Patent	Exemplary Evidence of Anticipation and/or Obviousness
		<p>“Alternatively, the predistorting means is arranged to compare the composite signal from the amplifying means with a plurality of different signals to provide, if necessary, the at least one new predistortion value.” 3:30-33.</p> <p>“The amplifier means is preferably a nonlinear amplifier. The predistortion means is preferably arranged to compensate for the nonlinearity of the phase and/or amplitude of the output of the amplifier.” 3:45-58.</p> <p>“A digital to analogue converter may be provided for converting the plurality of signals to analogue form before said signals are amplified by said amplifier means.</p> <p>The transmitter is preferably incorporated in a base station or alternatively in a mobile station.</p> <p>According to a second aspect of the present invention, there is provided a multi carrier frequency transmission method comprising the steps of receiving a plurality of different digital signals to be transmitted, said different signals to be transmitted on different carrier frequencies; combining said plurality of different signals to provide a composite signal comprising the different signals at the respective carrier frequencies; and amplifying said composite signal, wherein the method further comprises the steps of: predistorting the plurality of different digital signals prior to amplification of the composite signal by the amplification means; and altering the predistortion applied to subsequent signals in dependence on the difference between said different signals and the amplified signal.” 3:49-67.</p> <p>“Reference will now be made to FIG. 4 which shows a first embodiment of the present invention. In particular, the transmit part 102 of the base station 100 is shown. The base station 100 is in a cellular system of the type shown in FIG. 1.” 4:30-34.</p> <p>“The transmit part 102 of the base station 100 comprises N channel encoders 104 where N is the number of different frequencies on which the base station 100 will transmit signals. Each channel encoder 104 receives the data to be transmitted on the particular frequency associated with the given channel encoder 104. The data is placed in a suitable form for transmission. This may include digitising the data, encoding the data, interleaving the data and/or any other step required to be carried out. As mentioned hereinbefore, each channel is on a different frequency after the</p>

Claim No.	'204 Patent	Exemplary Evidence of Anticipation and/or Obviousness
		<p>modulator. The signals output by the channel encoders 104 are in digital form and are at a baseband frequency. Coding, interleaving etc is performed on the digital baseband signals.” 4:35-36.</p> <p>“The output of each channel encoder 104 is input to a respective digital modulator 106. Each digital modulator 106 also receives two outputs from the adaptive predistorter 108. The first output from the predistorter 108 provides one or more amplitude coefficients which are used to predistort the signal which is output by the digital modulator to compensate for the non linearity of an amplifier 122 with respect to amplitude. The second output from the predistorter 108 provides one or more phase coefficients which are used to predistort the signal which is output by the modulator 106 to compensate for phase distortion provided by the amplifier 122. The amplifier 122 will be described in more detail hereinafter.” 4:48-60.</p> <p>“The predistortion to compensate for the phase and amplitude distortion introduced by the amplifier 122 can take place at the same time. The predistortion can be performed during or more preferably after the modulation has been carried out by the modulator 106.” 5:6-10.</p> <p>“The output of the second bandpass filter 120 is input to the power amplifier 122 which amplifies the received input. The output of the amplifier 122 is input to a third bandpass filter 124 which is arranged to filter out any signal components introduced by the amplifier 122 which fall outside the radio frequency band of the signals to be transmitted. The output of the third bandpass filter 124 is passed to an antenna 126 which transmits the signals to the terminals in the cell associated with the base station.” 5:41-49.</p> <p>“The adaptive predistorter 108 does not, as in the first embodiment, have outputs connected to the digital modulators 106. The output of the combiner 110 is connected to the input of the predistorter 108. The output of the predistorter 108 is connected to the input of the digital to analogue convertor. The predistorter 108 thus predistorts the multicarrier output of the combiner 110 and outputs a predistorted multicarrier signal. The feedback path is the same in the first and second embodiments and accordingly the predistorter 108 operates in a similar manner to that shown in the first embodiment. However, phase correction is not applied and the amplitude correction is the</p>

Claim No.	'204 Patent	Exemplary Evidence of Anticipation and/or Obviousness
		<p>same for all frequencies. This solution is simple but may not provide the required performance in all cases.” 7:39-52.</p> <p>“Reference will now be made to FIG. 8 which shows a second predistorter 108 b which can be used in the second embodiment shown in FIG. 5. This second predistorter 108 comprises n subtractors 208 each of which receives an output from a respective one of the digital modulators. Each subtractor 208 also receives a corresponding input from the channelizer 140 as in the first embodiment. Each subtractor 208 thus receives two modulated signals. The two signals received by each subtractor 208 are subtracted one from the other to generate a difference signal. This output difference signal is input to the adaption algorithm block 204 which is the same as discussed in relation to the first predistorter of FIG. 7. As with the first predistorter of FIG. 7, the adaption algorithm block 204 also receives an input from the microcontroller 142 with information concerning the frequency. The adaption algorithm block 204 provides amplitude coefficients on its output which are output to the look-up table 200. Unlike the embodiment shown in FIG. 7, the look-up table receives the multicarrier signal from the combiner 110 which defines an address in the look-up table. Accordingly, the multicarrier signal is modified in accordance with the amplitude values from the look-up table and output to the digital to analogue convertor 112.” 7:53-8:8.</p> <p>“Reference is now made to FIG. 10 which shows a possible construction of the channeliser 140. The channeliser comprises n blocks 220, with one block provided for each frequency. Each block of the channeliser 220 comprises an input for receiving the output of the analogue to digital converter 138 and a frequency control signal from the microcontroller 142. The output from the analogue to digital converter 138 is input to first and second multipliers 222 and 224. The first multiplier 222 produces the I or in-band, component of the input signal whilst the second multiplier 224 produces the Q, or quadrature-phase component of the input signal. Each of the multipliers 222 and 224 receives a frequency from the numerically controlled oscillator 226. The frequency of the oscillator 226 is controlled by the frequency control input. The output of the oscillator 226 is connected directly to one of the multipliers 222 whilst the output for the second multipliers 224 is connected to a phase shifter 228 which shifts the phase of the output signal from the oscillator 226 by 90°. The phase shifted output signal of the oscillator 226 is input to the second multipliers 224.” 8:9-28.</p>

Claim No.	'204 Patent	Exemplary Evidence of Anticipation and/or Obviousness
		<p data-bbox="840 188 2116 290">“The output of each of the first and second multipliers 222 and 224 are connected to filters 230 and 232 which are arranged to filter out signal components introduced by the respective multipliers as well as other carriers within the multicarrier signal.” 8:29-33.</p> <p data-bbox="840 331 2116 545">“In the embodiments where the composite signal is predistorted, the combiner output consists of amplitude words, the correction occurring by adjusting the magnitude of the words. Nonlinearities in the amplifier output could be compensated by correcting the magnitude of the combiner output words with an inverse function. The correction may thus be dependent on the particular combiner output. This might occur by indexing a look-up table with the combiner output word and outputting the respective contents to the digital to analogue converter.” 9:18-27.</p> <div data-bbox="840 593 2116 1220"> </div> <p data-bbox="840 1264 929 1300">Fig. 4.</p>

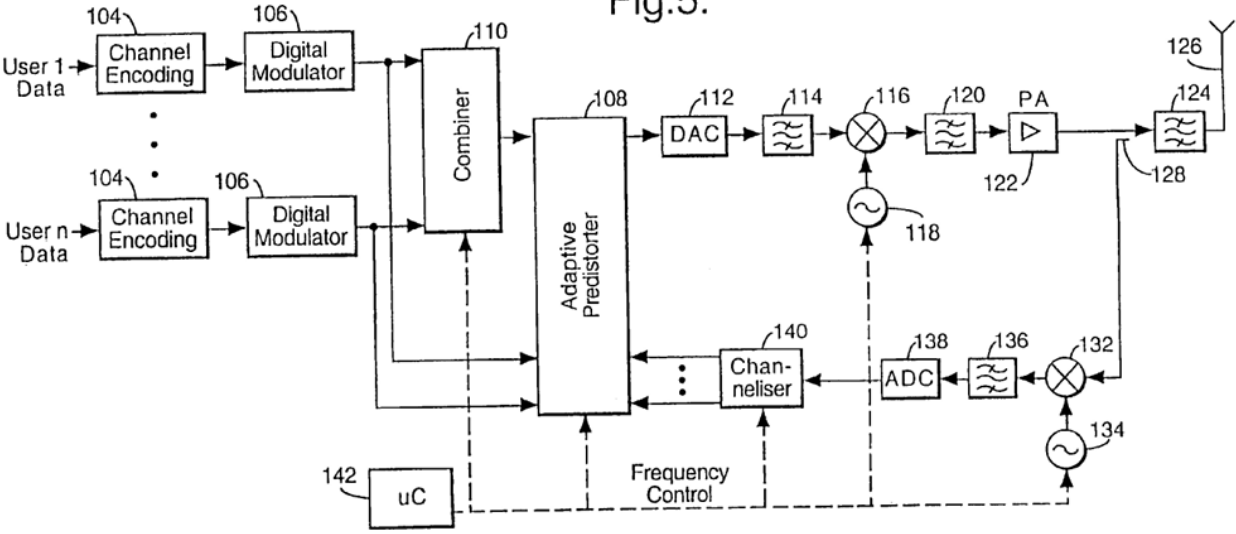
Claim No.	'204 Patent	Exemplary Evidence of Anticipation and/or Obviousness
		<p style="text-align: center;">Fig.5.</p>  <p style="text-align: center;">Fig. 5.</p>

Claim No.	'204 Patent	Exemplary Evidence of Anticipation and/or Obviousness
-----------	-------------	---

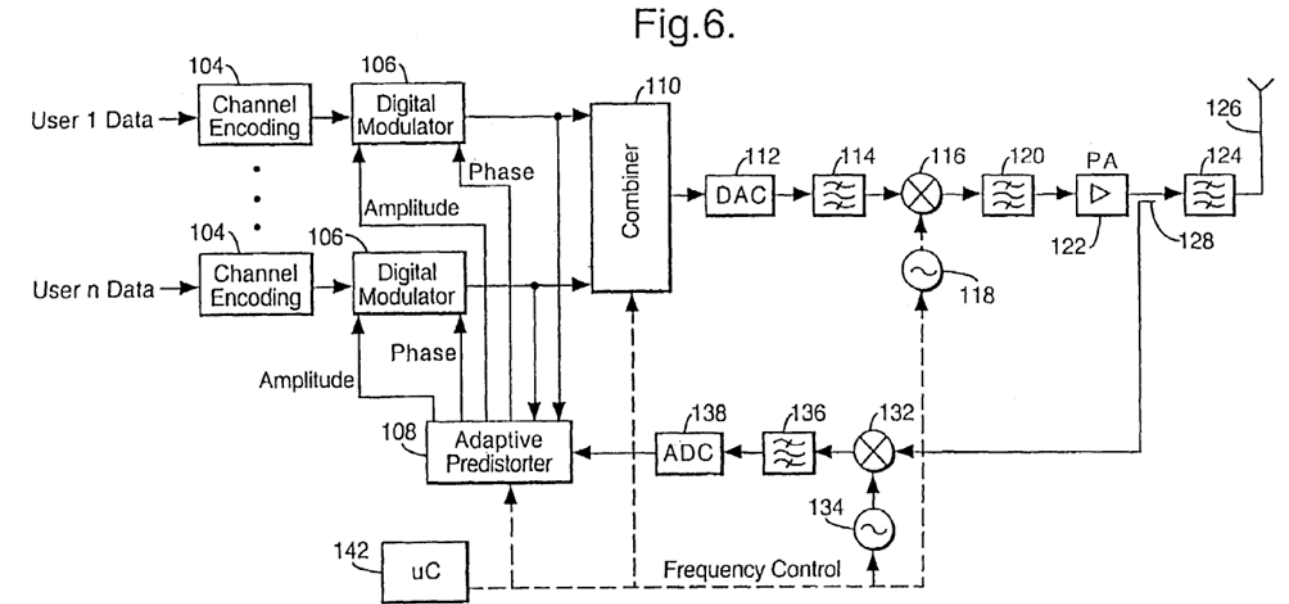
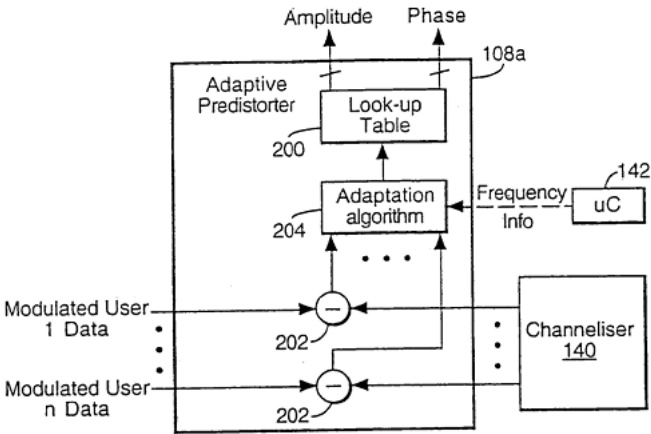
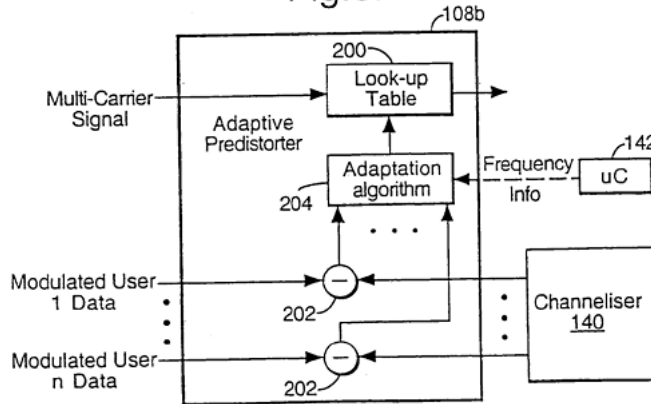
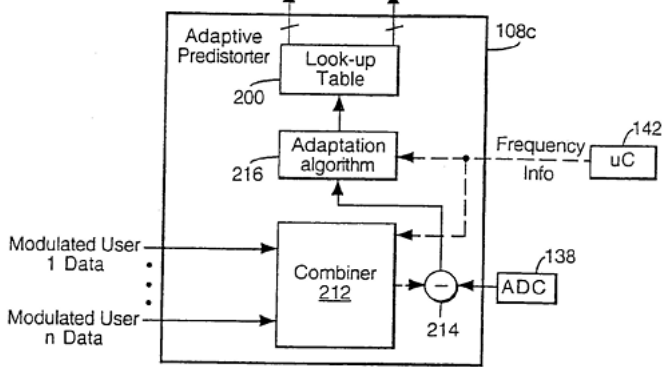
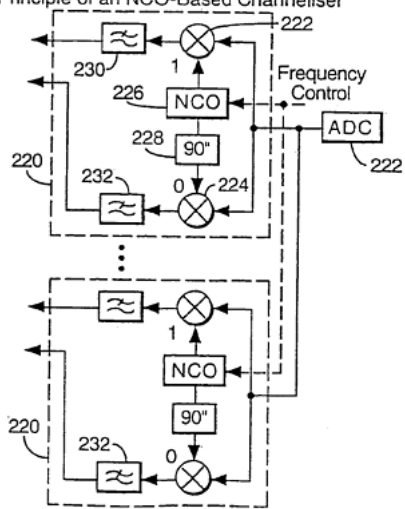

Fig. 6.

Claim No.	'204 Patent	Exemplary Evidence of Anticipation and/or Obviousness
		<p data-bbox="1144 188 1245 225">Fig.7.</p>  <p data-bbox="1144 788 1245 825">Fig.8.</p>  <p data-bbox="837 1286 1010 1323">Figs. 7 and 8.</p>

Claim No.	'204 Patent	Exemplary Evidence of Anticipation and/or Obviousness
		<p data-bbox="996 183 1288 223">Fig.9. Amplitude Phase</p>  <p data-bbox="974 678 1332 718">Fig.10. Principle of an NCO-Based Channeliser</p>  <p data-bbox="840 1284 985 1324">Figs. 9-10.</p>

Claim No.	'204 Patent	Exemplary Evidence of Anticipation and/or Obviousness
5	<p>The transmitter of claim 3, wherein said analyzing and modeling stage is further configured to:</p> <p>perform time alignment of complex baseband signals from sampling said outputs of said power amplifier; and perform the reconstruction of the complex baseband signals from sampling said outputs of said power amplifier.</p>	<p>Posti discloses and/or renders obvious the transmitter of claim 3, wherein said analyzing and modeling stage is further configured to: perform time alignment of complex baseband signals from sampling said outputs of said power amplifier; and perform the reconstruction of the complex baseband signals from sampling said outputs of said power amplifier.</p> <p><i>See</i> claim 3, <i>supra</i>, which is incorporated by reference herein.</p> <p><i>See, e.g.,</i></p> <p>“A multi frequency carrier transmitter comprises input means for receiving a plurality of different digital signals to be transmitted. The different signals are to be transmitted on different carrier frequencies. Amplifier means receive a composite signal comprising the different signals at the respective carrier frequencies and amplify the composite signal. Predistortion means predistort the plurality of digital signals prior to amplification of the composite signal by the amplification means. The predistortion provided by the predistortion means is subsequently altered in dependence on the difference between the input signals and the output at the amplifier means.” Abstract.</p> <p>“The present invention relates to a transmitter and a method of transmitting and in particular, but not exclusively, for use in a telecommunications network.”</p> <p>“The output of each transmit path 14–14' is connected to the input of a combiner 22 which combines the signals from each path 14–14' to provide a multicarrier signal. The output of the combiner 22 is connected to an antenna 24 which transmits the multicarrier signal containing each of the N different channels to the terminals in the cell served by the base station.” 1:53-59.</p> <p>“According to one aspect of the present invention, there is provided a multi frequency carrier transmitter comprising input means for receiving a plurality of different digital signals to be transmitted, said different signals to be transmitted on different carrier frequencies; amplifier means for receiving a composite signal comprising said different signals at the respective carrier frequencies and amplifying said composite signal; and predistortion means for predistorting said plurality of digital signals prior to amplification of the composite signal by said amplification means, said predistortion provided by said predistortion means being subsequently altered in</p>

Claim No.	'204 Patent	Exemplary Evidence of Anticipation and/or Obviousness
		<p>dependence on the difference between said input signals and the output at said amplifier means.” 2:43-55.</p> <p>“Accordingly, embodiments of the present invention provide a multi carrier transmitter which is able to deal with the problems of nonlinearity by using predistortion. The predistortion can be implemented more simply than the feedback method discussed in the prior art.” 2:55-60.</p> <p>“The output of the second bandpass filter 120 is input to the power amplifier 122 which amplifies the received input. The output of the amplifier 122 is input to a third bandpass filter 124 which is arranged to filter out any signal components introduced by the amplifier 122 which fall outside the radio frequency band of the signals to be transmitted. The output of the third bandpass filter 124 is passed to an antenna 126 which transmits the signals to the terminals in the cell associated with the base station.” 5:41-49.</p> <p>“The input means are preferably arranged to separately receive each of the different signals. Combiner means are preferably provided between the input means and the amplifier means for combining said plurality of different signals to provide a composite signal. This may be the composite signal input to the amplifier means or may be a composite signal at a lower, intermediate frequency. In the latter case, that composite signal at a lower frequency would be upconverted to provide the composite signal input to the amplifier means.” 2:61-3:3.</p> <p>“A feedback path may be arranged between the amplifying means and the predistorting means. Preferably, the predistorting means is arranged to compare the output from the amplifying means from the feedback path with the signals received by the receiving means and to provide, if necessary, at least one new predistortion value to be applied to at least one subsequent signal received by the receiving means. In this way, the predistorting means can adapt to changes in the operating conditions of the amplifier means.” 3:14-21.</p> <p>“Preferably, means are provided in the feedback path for separating the output of the amplifying means into a plurality of different signals. The predistorting means is preferably arranged to compare each of the separated signals with the corresponding signals received from the input means and to determine if the at least one predistortion value needs to be altered.” 3:23-29.</p>

Claim No.	'204 Patent	Exemplary Evidence of Anticipation and/or Obviousness
		<p>“Alternatively, the predistorting means is arranged to compare the composite signal from the amplifying means with a plurality of different signals to provide, if necessary, the at least one new predistortion value.” 3:30-33.</p> <p>“The amplifier means is preferably a nonlinear amplifier. The predistortion means is preferably arranged to compensate for the nonlinearity of the phase and/or amplitude of the output of the amplifier.” 3:45-58.</p> <p>“A digital to analogue converter may be provided for converting the plurality of signals to analogue form before said signals are amplified by said amplifier means.</p> <p>The transmitter is preferably incorporated in a base station or alternatively in a mobile station.</p> <p>According to a second aspect of the present invention, there is provided a multi carrier frequency transmission method comprising the steps of receiving a plurality of different digital signals to be transmitted, said different signals to be transmitted on different carrier frequencies; combining said plurality of different signals to provide a composite signal comprising the different signals at the respective carrier frequencies; and amplifying said composite signal, wherein the method further comprises the steps of: predistorting the plurality of different digital signals prior to amplification of the composite signal by the amplification means; and altering the predistortion applied to subsequent signals in dependence on the difference between said different signals and the amplified signal.” 3:49-67.</p> <p>“Reference will now be made to FIG. 4 which shows a first embodiment of the present invention. In particular, the transmit part 102 of the base station 100 is shown. The base station 100 is in a cellular system of the type shown in FIG. 1.” 4:30-34.</p> <p>“The transmit part 102 of the base station 100 comprises N channel encoders 104 where N is the number of different frequencies on which the base station 100 will transmit signals. Each channel encoder 104 receives the data to be transmitted on the particular frequency associated with the given channel encoder 104. The data is placed in a suitable form for transmission. This may include digitising the data, encoding the data, interleaving the data and/or any other step required to be carried out. As mentioned hereinbefore, each channel is on a different frequency after the</p>

Claim No.	'204 Patent	Exemplary Evidence of Anticipation and/or Obviousness
		<p>modulator. The signals output by the channel encoders 104 are in digital form and are at a baseband frequency. Coding, interleaving etc is performed on the digital baseband signals.” 4:35-36.</p> <p>“The output of each channel encoder 104 is input to a respective digital modulator 106. Each digital modulator 106 also receives two outputs from the adaptive predistorter 108. The first output from the predistorter 108 provides one or more amplitude coefficients which are used to predistort the signal which is output by the digital modulator to compensate for the non linearity of an amplifier 122 with respect to amplitude. The second output from the predistorter 108 provides one or more phase coefficients which are used to predistort the signal which is output by the modulator 106 to compensate for phase distortion provided by the amplifier 122. The amplifier 122 will be described in more detail hereinafter.” 4:48-60.</p> <p>“The predistortion to compensate for the phase and amplitude distortion introduced by the amplifier 122 can take place at the same time. The predistortion can be performed during or more preferably after the modulation has been carried out by the modulator 106.” 5:6-10.</p> <p>“The output of the second bandpass filter 120 is input to the power amplifier 122 which amplifies the received input. The output of the amplifier 122 is input to a third bandpass filter 124 which is arranged to filter out any signal components introduced by the amplifier 122 which fall outside the radio frequency band of the signals to be transmitted. The output of the third bandpass filter 124 is passed to an antenna 126 which transmits the signals to the terminals in the cell associated with the base station.” 5:41-49.</p> <p>“The adaptive predistorter 108 does not, as in the first embodiment, have outputs connected to the digital modulators 106. The output of the combiner 110 is connected to the input of the predistorter 108. The output of the predistorter 108 is connected to the input of the digital to analogue convertor. The predistorter 108 thus predistorts the multicarrier output of the combiner 110 and outputs a predistorted multicarrier signal. The feedback path is the same in the first and second embodiments and accordingly the predistorter 108 operates in a similar manner to that shown in the first embodiment. However, phase correction is not applied and the amplitude correction is the</p>

Claim No.	'204 Patent	Exemplary Evidence of Anticipation and/or Obviousness
		<p>same for all frequencies. This solution is simple but may not provide the required performance in all cases.” 7:39-52.</p> <p>“Reference will now be made to FIG. 8 which shows a second predistorter 108 b which can be used in the second embodiment shown in FIG. 5. This second predistorter 108 comprises n subtractors 208 each of which receives an output from a respective one of the digital modulators. Each subtracter 208 also receives a corresponding input from the channelizer 140 as in the first embodiment. Each subtracter 208 thus receives two modulated signals. The two signals received by each subtracter 208 are subtracted one from the other to generate a difference signal. This output difference signal is input to the adaption algorithm block 204 which is the same as discussed in relation to the first predistorter of FIG. 7. As with the first predistorter of FIG. 7, the adaption algorithm block 204 also receives an input from the microcontroller 142 with information concerning the frequency. The adaption algorithm block 204 provides amplitude coefficients on its output which are output to the look-up table 200. Unlike the embodiment shown in FIG. 7, the look-up table receives the multicarrier signal from the combiner 110 which defines an address in the look-up table. Accordingly, the multicarrier signal is modified in accordance with the amplitude values from the look-up table and output to the digital to analogue convertor 112.” 7:53-8:8.</p> <p>“Reference is now made to FIG. 10 which shows a possible construction of the channeliser 140. The channeliser comprises n blocks 220, with one block provided for each frequency. Each block of the channeliser 220 comprises an input for receiving the output of the analogue to digital converter 138 and a frequency control signal from the microcontroller 142. The output from the analogue to digital converter 138 is input to first and second multipliers 222 and 224. The first multiplier 222 produces the I or in-band, component of the input signal whilst the second multiplier 224 produces the Q, or quadrature-phase component of the input signal. Each of the multipliers 222 and 224 receives a frequency from the numerically controlled oscillator 226. The frequency of the oscillator 226 is controlled by the frequency control input. The output of the oscillator 226 is connected directly to one of the multipliers 222 whilst the output for the second multipliers 224 is connected to a phase shifter 228 which shifts the phase of the output signal from the oscillator 226 by 90°. The phase shifted output signal of the oscillator 226 is input to the second multipliers 224.” 8:9-28.</p>

Claim No.	'204 Patent	Exemplary Evidence of Anticipation and/or Obviousness
		<p>“The output of each of the first and second multipliers 222 and 224 are connected to filters 230 and 232 which are arranged to filter out signal components introduced by the respective multipliers as well as other carriers within the multicarrier signal.” 8:29-33.</p> <p>“The frequency information provided by the microcontroller 142 is used by the predistorter 108 in the third embodiment to reconstruct the composite signal using any appropriate method. The methods require frequency information. One example is the inverse fast fourier transform technique which creates a spectral representation of the signal sampled in the time domain.” 8:37-43.</p> <p>“In the embodiments where the composite signal is predistorted, the combiner output consists of amplitude words, the correction occurring by adjusting the magnitude of the words. Nonlinearities in the amplifier output could be compensated by correcting the magnitude of the combiner output words with an inverse function. The correction may thus be dependent on the particular combiner output. This might occur by indexing a look-up table with the combiner output word and outputting the respective contents to the digital to analogue converter.” 9:18-27.</p>

Claim No.	'204 Patent	Exemplary Evidence of Anticipation and/or Obviousness
		<p style="text-align: center;">Fig.4.</p> <p style="text-align: center;">Fig. 4.</p>

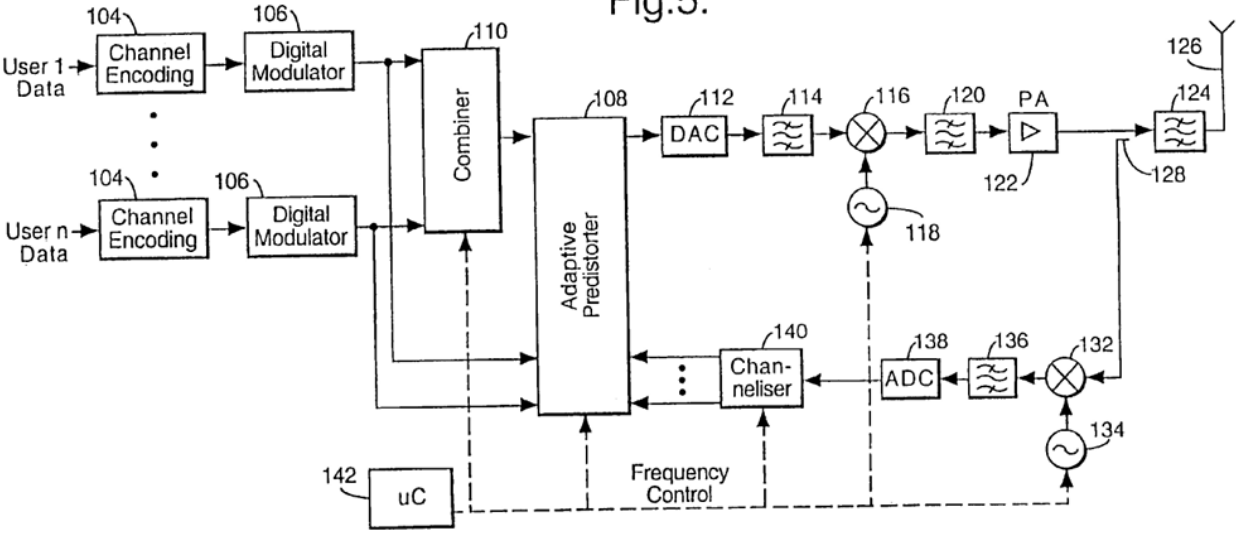
Claim No.	'204 Patent	Exemplary Evidence of Anticipation and/or Obviousness
		<p style="text-align: center;">Fig.5.</p>  <p style="text-align: center;">Fig. 5.</p>

Claim No.	'204 Patent	Exemplary Evidence of Anticipation and/or Obviousness
-----------	-------------	---

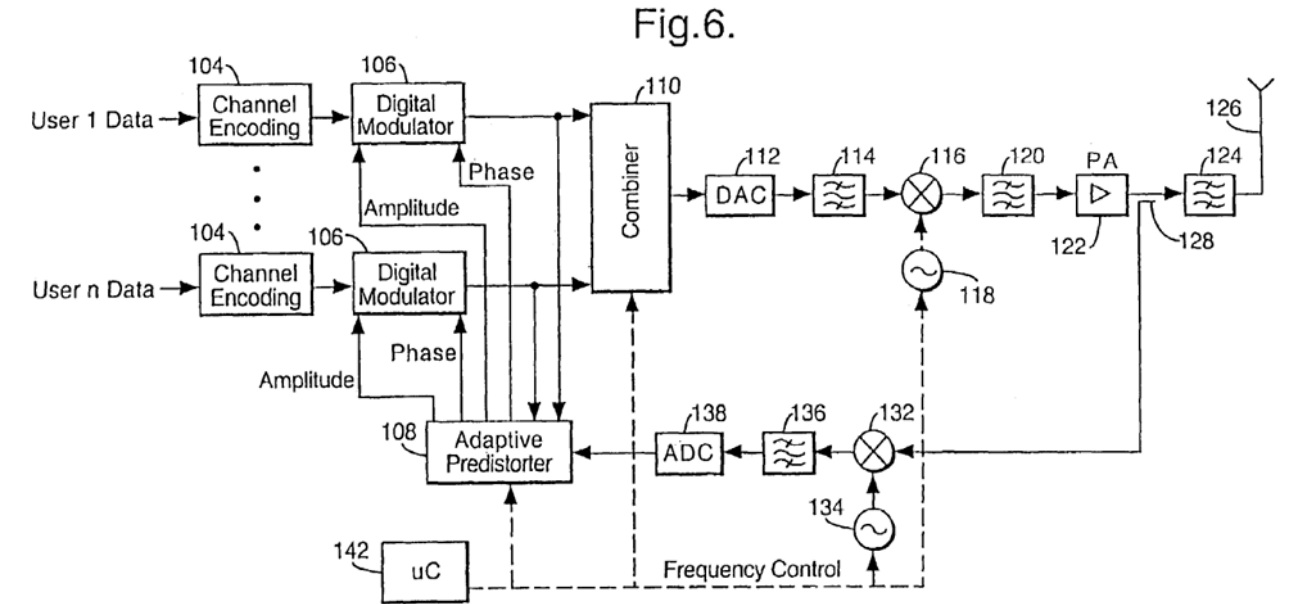
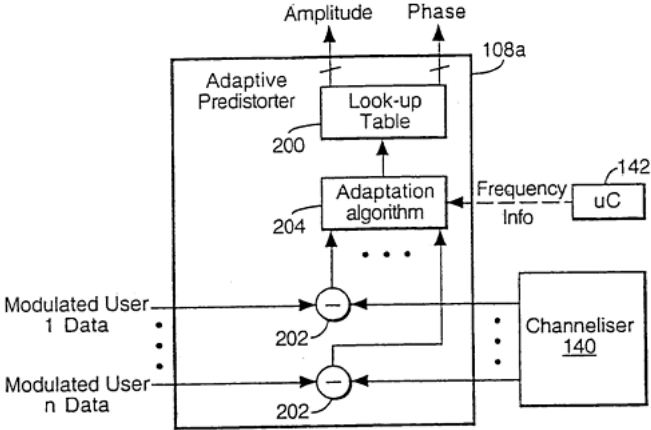
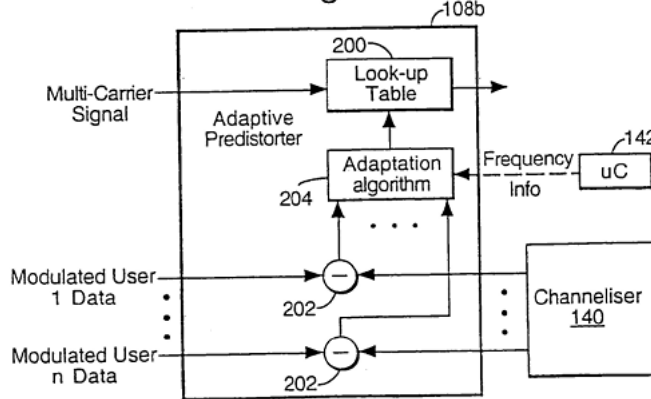
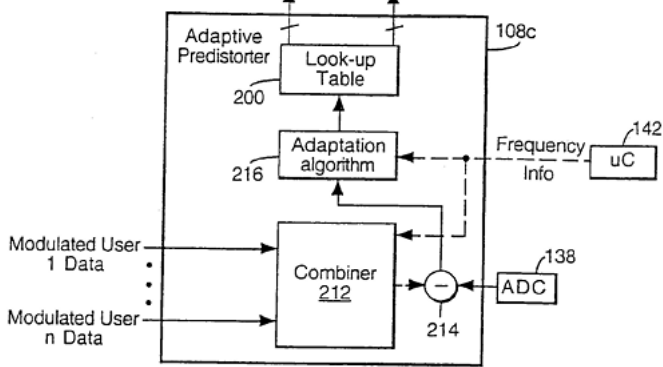
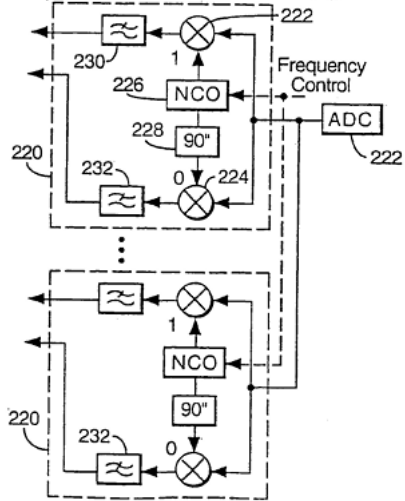

Fig. 6.

Claim No.	'204 Patent	Exemplary Evidence of Anticipation and/or Obviousness
		<p data-bbox="1144 188 1245 225">Fig.7.</p>  <p data-bbox="1144 788 1245 825">Fig.8.</p>  <p data-bbox="837 1286 1010 1323">Figs. 7 and 8.</p>

Claim No.	'204 Patent	Exemplary Evidence of Anticipation and/or Obviousness
		<p data-bbox="996 183 1276 223">Fig.9. Amplitude Phase</p>  <p data-bbox="974 678 1086 718">Fig.10.</p> <p data-bbox="974 718 1332 742">Principle of an NCO-Based Channeliser</p>  <p data-bbox="840 1284 974 1324">Figs. 9-10.</p>

Claim No.	'204 Patent	Exemplary Evidence of Anticipation and/or Obviousness
6	<p>The transmitter of claim 2, wherein said signal observation feedback loop further is further configured to:</p> <p>down-convert samples of the RF signals at said output of the power amplifier; and</p> <p>extract from said down-converted samples a baseband equivalent for all frequency channels.</p>	<p>Posti discloses and/or renders obvious the transmitter of claim 2, wherein said signal observation feedback loop further is further configured to: down-convert samples of the RF signals at said output of the power amplifier; and extract from said down-converted samples a baseband equivalent for all frequency channels.</p> <p><i>See claim 2, supra</i>, which is incorporated by reference herein.</p> <p><i>See, e.g.,</i></p> <p>“A multi frequency carrier transmitter comprises input means for receiving a plurality of different digital signals to be transmitted. The different signals are to be transmitted on different carrier frequencies. Amplifier means receive a composite signal comprising the different signals at the respective carrier frequencies and amplify the composite signal. Predistortion means predistort the plurality of digital signals prior to amplification of the composite signal by the amplification means. The predistortion provided by the predistortion means is subsequently altered in dependence on the difference between the input signals and the output at the amplifier means.” Abstract.</p> <p>“The present invention relates to a transmitter and a method of transmitting and in particular, but not exclusively, for use in a telecommunications network.”</p> <p>“The output of each transmit path 14–14' is connected to the input of a combiner 22 which combines the signals from each path 14–14' to provide a multicarrier signal. The output of the combiner 22 is connected to an antenna 24 which transmits the multicarrier signal containing each of the N different channels to the terminals in the cell served by the base station.” 1:53-59.</p> <p>“According to one aspect of the present invention, there is provided a multi frequency carrier transmitter comprising input means for receiving a plurality of different digital signals to be transmitted, said different signals to be transmitted on different carrier frequencies; amplifier means for receiving a composite signal comprising said different signals at the respective carrier frequencies and amplifying said composite signal; and predistortion means for predistorting said plurality of digital signals prior to amplification of the composite signal by said amplification means, said predistortion provided by said predistortion means being subsequently altered in</p>

Claim No.	'204 Patent	Exemplary Evidence of Anticipation and/or Obviousness
		<p>dependence on the difference between said input signals and the output at said amplifier means.” 2:43-55.</p> <p>“Accordingly, embodiments of the present invention provide a multi carrier transmitter which is able to deal with the problems of nonlinearity by using predistortion. The predistortion can be implemented more simply than the feedback method discussed in the prior art.” 2:55-60.</p> <p>“The output of the second bandpass filter 120 is input to the power amplifier 122 which amplifies the received input. The output of the amplifier 122 is input to a third bandpass filter 124 which is arranged to filter out any signal components introduced by the amplifier 122 which fall outside the radio frequency band of the signals to be transmitted. The output of the third bandpass filter 124 is passed to an antenna 126 which transmits the signals to the terminals in the cell associated with the base station.” 5:41-49.</p> <p>“The input means are preferably arranged to separately receive each of the different signals. Combiner means are preferably provided between the input means and the amplifier means for combining said plurality of different signals to provide a composite signal. This may be the composite signal input to the amplifier means or may be a composite signal at a lower, intermediate frequency. In the latter case, that composite signal at a lower frequency would be upconverted to provide the composite signal input to the amplifier means.” 2:61-3:3.</p> <p>“A feedback path may be arranged between the amplifying means and the predistorting means. Preferably, the predistorting means is arranged to compare the output from the amplifying means from the feedback path with the signals received by the receiving means and to provide, if necessary, at least one new predistortion value to be applied to at least one subsequent signal received by the receiving means. In this way, the predistorting means can adapt to changes in the operating conditions of the amplifier means.” 3:14-21.</p> <p>“Preferably, means are provided in the feedback path for separating the output of the amplifying means into a plurality of different signals. The predistorting means is preferably arranged to compare each of the separated signals with the corresponding signals received from the input means and to determine if the at least one predistortion value needs to be altered.” 3:23-29.</p>

Claim No.	'204 Patent	Exemplary Evidence of Anticipation and/or Obviousness
		<p>“Alternatively, the predistorting means is arranged to compare the composite signal from the amplifying means with a plurality of different signals to provide, if necessary, the at least one new predistortion value.” 3:30-33.</p> <p>“The amplifier means is preferably a nonlinear amplifier. The predistortion means is preferably arranged to compensate for the nonlinearity of the phase and/or amplitude of the output of the amplifier.” 3:45-58.</p> <p>“A digital to analogue converter may be provided for converting the plurality of signals to analogue form before said signals are amplified by said amplifier means.</p> <p>The transmitter is preferably incorporated in a base station or alternatively in a mobile station.</p> <p>According to a second aspect of the present invention, there is provided a multi carrier frequency transmission method comprising the steps of receiving a plurality of different digital signals to be transmitted, said different signals to be transmitted on different carrier frequencies; combining said plurality of different signals to provide a composite signal comprising the different signals at the respective carrier frequencies; and amplifying said composite signal, wherein the method further comprises the steps of: predistorting the plurality of different digital signals prior to amplification of the composite signal by the amplification means; and altering the predistortion applied to subsequent signals in dependence on the difference between said different signals and the amplified signal.” 3:49-67.</p> <p>“Reference will now be made to FIG. 4 which shows a first embodiment of the present invention. In particular, the transmit part 102 of the base station 100 is shown. The base station 100 is in a cellular system of the type shown in FIG. 1.” 4:30-34.</p> <p>“The transmit part 102 of the base station 100 comprises N channel encoders 104 where N is the number of different frequencies on which the base station 100 will transmit signals. Each channel encoder 104 receives the data to be transmitted on the particular frequency associated with the given channel encoder 104. The data is placed in a suitable form for transmission. This may include digitising the data, encoding the data, interleaving the data and/or any other step required to be carried out. As mentioned hereinbefore, each channel is on a different frequency after the</p>

Claim No.	'204 Patent	Exemplary Evidence of Anticipation and/or Obviousness
		<p>modulator. The signals output by the channel encoders 104 are in digital form and are at a baseband frequency. Coding, interleaving etc is performed on the digital baseband signals.” 4:35-36.</p> <p>“The output of each channel encoder 104 is input to a respective digital modulator 106. Each digital modulator 106 also receives two outputs from the adaptive predistorter 108. The first output from the predistorter 108 provides one or more amplitude coefficients which are used to predistort the signal which is output by the digital modulator to compensate for the non linearity of an amplifier 122 with respect to amplitude. The second output from the predistorter 108 provides one or more phase coefficients which are used to predistort the signal which is output by the modulator 106 to compensate for phase distortion provided by the amplifier 122. The amplifier 122 will be described in more detail hereinafter.” 4:48-60.</p> <p>“The predistortion to compensate for the phase and amplitude distortion introduced by the amplifier 122 can take place at the same time. The predistortion can be performed during or more preferably after the modulation has been carried out by the modulator 106.” 5:6-10.</p> <p>“The output of the second bandpass filter 120 is input to the power amplifier 122 which amplifies the received input. The output of the amplifier 122 is input to a third bandpass filter 124 which is arranged to filter out any signal components introduced by the amplifier 122 which fall outside the radio frequency band of the signals to be transmitted. The output of the third bandpass filter 124 is passed to an antenna 126 which transmits the signals to the terminals in the cell associated with the base station.” 5:41-49.</p> <p>“The adaptive predistorter 108 does not, as in the first embodiment, have outputs connected to the digital modulators 106. The output of the combiner 110 is connected to the input of the predistorter 108. The output of the predistorter 108 is connected to the input of the digital to analogue convertor. The predistorter 108 thus predistorts the multicarrier output of the combiner 110 and outputs a predistorted multicarrier signal. The feedback path is the same in the first and second embodiments and accordingly the predistorter 108 operates in a similar manner to that shown in the first embodiment. However, phase correction is not applied and the amplitude correction is the</p>

Claim No.	'204 Patent	Exemplary Evidence of Anticipation and/or Obviousness
		<p>same for all frequencies. This solution is simple but may not provide the required performance in all cases.” 7:39-52.</p> <p>“Reference will now be made to FIG. 8 which shows a second predistorter 108 b which can be used in the second embodiment shown in FIG. 5. This second predistorter 108 comprises n subtractors 208 each of which receives an output from a respective one of the digital modulators. Each subtractor 208 also receives a corresponding input from the channelizer 140 as in the first embodiment. Each subtractor 208 thus receives two modulated signals. The two signals received by each subtractor 208 are subtracted one from the other to generate a difference signal. This output difference signal is input to the adaption algorithm block 204 which is the same as discussed in relation to the first predistorter of FIG. 7. As with the first predistorter of FIG. 7, the adaption algorithm block 204 also receives an input from the microcontroller 142 with information concerning the frequency. The adaption algorithm block 204 provides amplitude coefficients on its output which are output to the look-up table 200. Unlike the embodiment shown in FIG. 7, the look-up table receives the multicarrier signal from the combiner 110 which defines an address in the look-up table. Accordingly, the multicarrier signal is modified in accordance with the amplitude values from the look-up table and output to the digital to analogue convertor 112.” 7:53-8:8.</p> <p>“Reference is now made to FIG. 10 which shows a possible construction of the channeliser 140. The channeliser comprises n blocks 220, with one block provided for each frequency. Each block of the channeliser 220 comprises an input for receiving the output of the analogue to digital converter 138 and a frequency control signal from the microcontroller 142. The output from the analogue to digital converter 138 is input to first and second multipliers 222 and 224. The first multiplier 222 produces the I or in-band, component of the input signal whilst the second multiplier 224 produces the Q, or quadrature-phase component of the input signal. Each of the multipliers 222 and 224 receives a frequency from the numerically controlled oscillator 226. The frequency of the oscillator 226 is controlled by the frequency control input. The output of the oscillator 226 is connected directly to one of the multipliers 222 whilst the output for the second multipliers 224 is connected to a phase shifter 228 which shifts the phase of the output signal from the oscillator 226 by 90°. The phase shifted output signal of the oscillator 226 is input to the second multipliers 224.” 8:9-28.</p>

Claim No.	'204 Patent	Exemplary Evidence of Anticipation and/or Obviousness
		<p>“The output of each of the first and second multipliers 222 and 224 are connected to filters 230 and 232 which are arranged to filter out signal components introduced by the respective multipliers as well as other carriers within the multicarrier signal.” 8:29-33.</p> <p>“The frequency information provided by the microcontroller 142 is used by the predistorter 108 in the third embodiment to reconstruct the composite signal using any appropriate method. The methods require frequency information. One example is the inverse fast fourier transform technique which creates a spectral representation of the signal sampled in the time domain.” 8:37-43.</p> <p>“In the embodiments where the composite signal is predistorted, the combiner output consists of amplitude words, the correction occurring by adjusting the magnitude of the words. Nonlinearities in the amplifier output could be compensated by correcting the magnitude of the combiner output words with an inverse function. The correction may thus be dependent on the particular combiner output. This might occur by indexing a look-up table with the combiner output word and outputting the respective contents to the digital to analogue converter.” 9:18-27.</p>

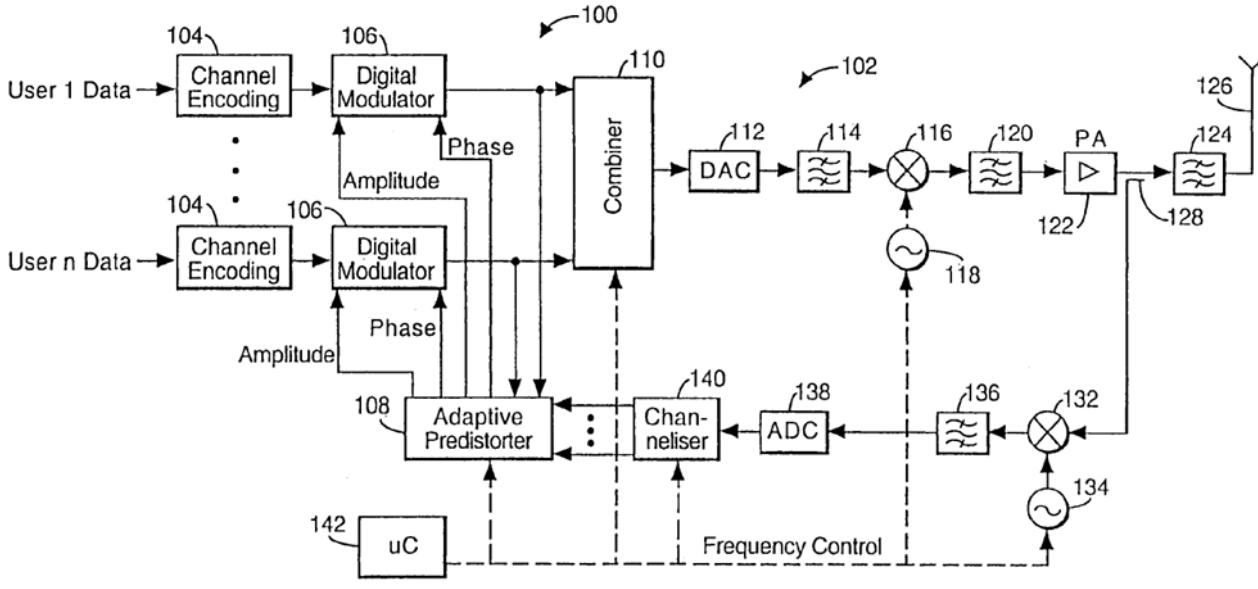
Claim No.	'204 Patent	Exemplary Evidence of Anticipation and/or Obviousness
		<p style="text-align: center;">Fig.4.</p>  <p style="text-align: center;">Fig. 4.</p>

Claim No.	'204 Patent	Exemplary Evidence of Anticipation and/or Obviousness
		<p style="text-align: center;">Fig.5.</p> <p style="text-align: center;">Fig. 5.</p>

Claim No.	'204 Patent	Exemplary Evidence of Anticipation and/or Obviousness
-----------	-------------	---

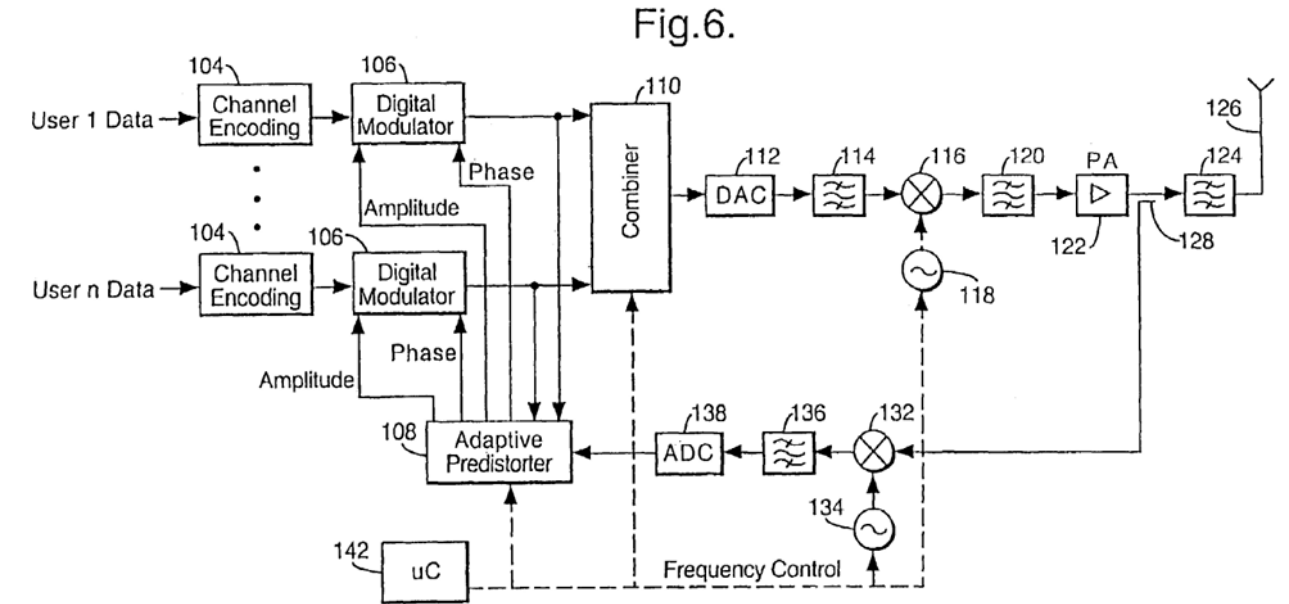
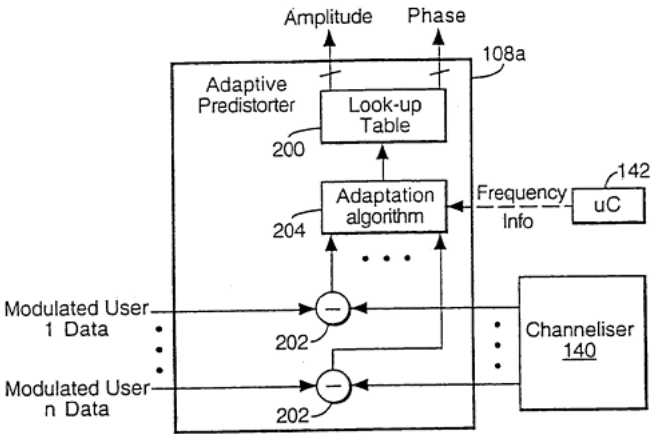
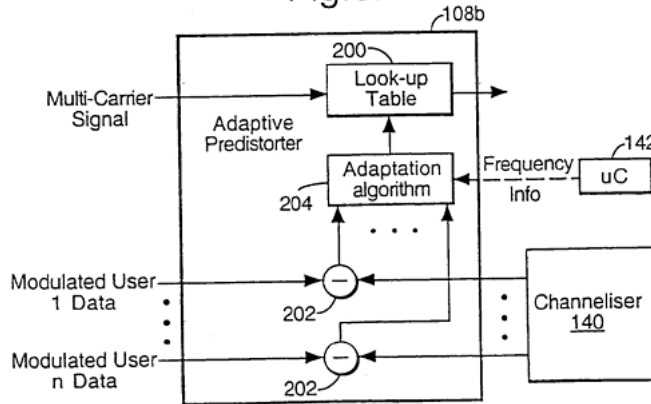
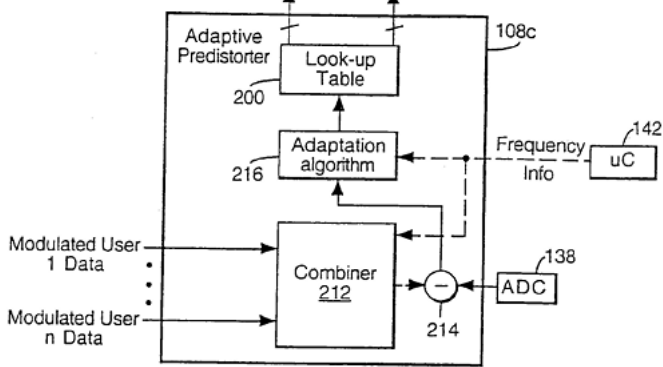
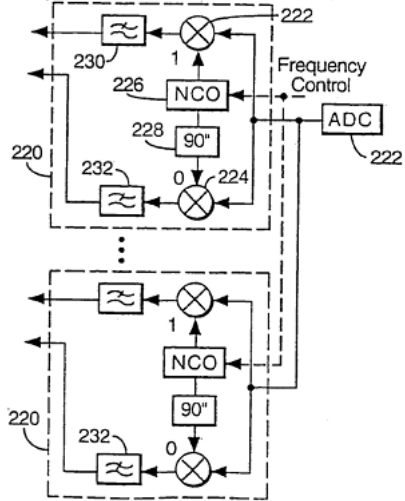

Fig. 6.

Claim No.	'204 Patent	Exemplary Evidence of Anticipation and/or Obviousness
		<p data-bbox="1144 188 1245 225">Fig.7.</p>  <p data-bbox="1144 788 1245 825">Fig.8.</p>  <p data-bbox="837 1286 1010 1323">Figs. 7 and 8.</p>

Claim No.	'204 Patent	Exemplary Evidence of Anticipation and/or Obviousness
		<p data-bbox="996 183 1276 223">Fig.9. Amplitude Phase</p>  <p data-bbox="974 678 1086 710">Fig.10.</p> <p data-bbox="974 718 1332 742">Principle of an NCO-Based Channeliser</p>  <p data-bbox="840 1284 974 1324">Figs. 9-10.</p>

Claim No.	'204 Patent	Exemplary Evidence of Anticipation and/or Obviousness
7	<p>The transmitter of claim 2, wherein said signal observation feedback loop further comprises for each channel an RF filter;</p> <p>a signal down conversion block; and</p> <p>an analog-to-digital converter (ADC).</p>	<p>Posti discloses and/or renders obvious the transmitter of claim 2, wherein said signal observation feedback loop further comprises for each channel an RF filter; a signal down conversion block; and an analog-to-digital converter (ADC).</p> <p><i>See</i> claim 2, <i>supra</i>, which is incorporated by reference herein.</p> <p><i>See, e.g.,</i></p> <p>“A multi frequency carrier transmitter comprises input means for receiving a plurality of different digital signals to be transmitted. The different signals are to be transmitted on different carrier frequencies. Amplifier means receive a composite signal comprising the different signals at the respective carrier frequencies and amplify the composite signal. Predistortion means predistort the plurality of digital signals prior to amplification of the composite signal by the amplification means. The predistortion provided by the predistortion means is subsequently altered in dependence on the difference between the input signals and the output at the amplifier means.” Abstract.</p> <p>“The present invention relates to a transmitter and a method of transmitting and in particular, but not exclusively, for use in a telecommunications network.”</p> <p>“The output of each transmit path 14–14' is connected to the input of a combiner 22 which combines the signals from each path 14–14' to provide a multicarrier signal. The output of the combiner 22 is connected to an antenna 24 which transmits the multicarrier signal containing each of the N different channels to the terminals in the cell served by the base station.” 1:53-59.</p> <p>“According to one aspect of the present invention, there is provided a multi frequency carrier transmitter comprising input means for receiving a plurality of different digital signals to be transmitted, said different signals to be transmitted on different carrier frequencies; amplifier means for receiving a composite signal comprising said different signals at the respective carrier frequencies and amplifying said composite signal; and predistortion means for predistorting said plurality of digital signals prior to amplification of the composite signal by said amplification means, said predistortion provided by said predistortion means being subsequently altered in</p>

Claim No.	'204 Patent	Exemplary Evidence of Anticipation and/or Obviousness
		<p>dependence on the difference between said input signals and the output at said amplifier means.” 2:43-55.</p> <p>“Accordingly, embodiments of the present invention provide a multi carrier transmitter which is able to deal with the problems of nonlinearity by using predistortion. The predistortion can be implemented more simply than the feedback method discussed in the prior art.” 2:55-60.</p> <p>“The output of the second bandpass filter 120 is input to the power amplifier 122 which amplifies the received input. The output of the amplifier 122 is input to a third bandpass filter 124 which is arranged to filter out any signal components introduced by the amplifier 122 which fall outside the radio frequency band of the signals to be transmitted. The output of the third bandpass filter 124 is passed to an antenna 126 which transmits the signals to the terminals in the cell associated with the base station.” 5:41-49.</p> <p>“The input means are preferably arranged to separately receive each of the different signals. Combiner means are preferably provided between the input means and the amplifier means for combining said plurality of different signals to provide a composite signal. This may be the composite signal input to the amplifier means or may be a composite signal at a lower, intermediate frequency. In the latter case, that composite signal at a lower frequency would be upconverted to provide the composite signal input to the amplifier means.” 2:61-3:3.</p> <p>“A feedback path may be arranged between the amplifying means and the predistorting means. Preferably, the predistorting means is arranged to compare the output from the amplifying means from the feedback path with the signals received by the receiving means and to provide, if necessary, at least one new predistortion value to be applied to at least one subsequent signal received by the receiving means. In this way, the predistorting means can adapt to changes in the operating conditions of the amplifier means.” 3:14-21.</p> <p>“Preferably, means are provided in the feedback path for separating the output of the amplifying means into a plurality of different signals. The predistorting means is preferably arranged to compare each of the separated signals with the corresponding signals received from the input means and to determine if the at least one predistortion value needs to be altered.” 3:23-29.</p>

Claim No.	'204 Patent	Exemplary Evidence of Anticipation and/or Obviousness
		<p>“Alternatively, the predistorting means is arranged to compare the composite signal from the amplifying means with a plurality of different signals to provide, if necessary, the at least one new predistortion value.” 3:30-33.</p> <p>“The amplifier means is preferably a nonlinear amplifier. The predistortion means is preferably arranged to compensate for the nonlinearity of the phase and/or amplitude of the output of the amplifier.” 3:45-58.</p> <p>“A digital to analogue converter may be provided for converting the plurality of signals to analogue form before said signals are amplified by said amplifier means.</p> <p>The transmitter is preferably incorporated in a base station or alternatively in a mobile station.</p> <p>According to a second aspect of the present invention, there is provided a multi carrier frequency transmission method comprising the steps of receiving a plurality of different digital signals to be transmitted, said different signals to be transmitted on different carrier frequencies; combining said plurality of different signals to provide a composite signal comprising the different signals at the respective carrier frequencies; and amplifying said composite signal, wherein the method further comprises the steps of: predistorting the plurality of different digital signals prior to amplification of the composite signal by the amplification means; and altering the predistortion applied to subsequent signals in dependence on the difference between said different signals and the amplified signal.” 3:49-67.</p> <p>“Reference will now be made to FIG. 4 which shows a first embodiment of the present invention. In particular, the transmit part 102 of the base station 100 is shown. The base station 100 is in a cellular system of the type shown in FIG. 1.” 4:30-34.</p> <p>“The transmit part 102 of the base station 100 comprises N channel encoders 104 where N is the number of different frequencies on which the base station 100 will transmit signals. Each channel encoder 104 receives the data to be transmitted on the particular frequency associated with the given channel encoder 104. The data is placed in a suitable form for transmission. This may include digitising the data, encoding the data, interleaving the data and/or any other step required to be carried out. As mentioned hereinbefore, each channel is on a different frequency after the</p>

Claim No.	'204 Patent	Exemplary Evidence of Anticipation and/or Obviousness
		<p>modulator. The signals output by the channel encoders 104 are in digital form and are at a baseband frequency. Coding, interleaving etc is performed on the digital baseband signals.” 4:35-36.</p> <p>“The output of each channel encoder 104 is input to a respective digital modulator 106. Each digital modulator 106 also receives two outputs from the adaptive predistorter 108. The first output from the predistorter 108 provides one or more amplitude coefficients which are used to predistort the signal which is output by the digital modulator to compensate for the non linearity of an amplifier 122 with respect to amplitude. The second output from the predistorter 108 provides one or more phase coefficients which are used to predistort the signal which is output by the modulator 106 to compensate for phase distortion provided by the amplifier 122. The amplifier 122 will be described in more detail hereinafter.” 4:48-60.</p> <p>“The predistortion to compensate for the phase and amplitude distortion introduced by the amplifier 122 can take place at the same time. The predistortion can be performed during or more preferably after the modulation has been carried out by the modulator 106.” 5:6-10.</p> <p>“The output of the second bandpass filter 120 is input to the power amplifier 122 which amplifies the received input. The output of the amplifier 122 is input to a third bandpass filter 124 which is arranged to filter out any signal components introduced by the amplifier 122 which fall outside the radio frequency band of the signals to be transmitted. The output of the third bandpass filter 124 is passed to an antenna 126 which transmits the signals to the terminals in the cell associated with the base station.” 5:41-49.</p> <p>“The adaptive predistorter 108 does not, as in the first embodiment, have outputs connected to the digital modulators 106. The output of the combiner 110 is connected to the input of the predistorter 108. The output of the predistorter 108 is connected to the input of the digital to analogue convertor. The predistorter 108 thus predistorts the multicarrier output of the combiner 110 and outputs a predistorted multicarrier signal. The feedback path is the same in the first and second embodiments and accordingly the predistorter 108 operates in a similar manner to that shown in the first embodiment. However, phase correction is not applied and the amplitude correction is the</p>

Claim No.	'204 Patent	Exemplary Evidence of Anticipation and/or Obviousness
		<p>same for all frequencies. This solution is simple but may not provide the required performance in all cases.” 7:39-52.</p> <p>“Reference will now be made to FIG. 8 which shows a second predistorter 108 b which can be used in the second embodiment shown in FIG. 5. This second predistorter 108 comprises n subtractors 208 each of which receives an output from a respective one of the digital modulators. Each subtractor 208 also receives a corresponding input from the channelizer 140 as in the first embodiment. Each subtractor 208 thus receives two modulated signals. The two signals received by each subtractor 208 are subtracted one from the other to generate a difference signal. This output difference signal is input to the adaption algorithm block 204 which is the same as discussed in relation to the first predistorter of FIG. 7. As with the first predistorter of FIG. 7, the adaption algorithm block 204 also receives an input from the microcontroller 142 with information concerning the frequency. The adaption algorithm block 204 provides amplitude coefficients on its output which are output to the look-up table 200. Unlike the embodiment shown in FIG. 7, the look-up table receives the multicarrier signal from the combiner 110 which defines an address in the look-up table. Accordingly, the multicarrier signal is modified in accordance with the amplitude values from the look-up table and output to the digital to analogue convertor 112.” 7:53-8:8.</p> <p>“Reference is now made to FIG. 10 which shows a possible construction of the channeliser 140. The channeliser comprises n blocks 220, with one block provided for each frequency. Each block of the channeliser 220 comprises an input for receiving the output of the analogue to digital converter 138 and a frequency control signal from the microcontroller 142. The output from the analogue to digital converter 138 is input to first and second multipliers 222 and 224. The first multiplier 222 produces the I or in-band, component of the input signal whilst the second multiplier 224 produces the Q, or quadrature-phase component of the input signal. Each of the multipliers 222 and 224 receives a frequency from the numerically controlled oscillator 226. The frequency of the oscillator 226 is controlled by the frequency control input. The output of the oscillator 226 is connected directly to one of the multipliers 222 whilst the output for the second multipliers 224 is connected to a phase shifter 228 which shifts the phase of the output signal from the oscillator 226 by 90°. The phase shifted output signal of the oscillator 226 is input to the second multipliers 224.” 8:9-28.</p>

Claim No.	'204 Patent	Exemplary Evidence of Anticipation and/or Obviousness
		<p>“The output of each of the first and second multipliers 222 and 224 are connected to filters 230 and 232 which are arranged to filter out signal components introduced by the respective multipliers as well as other carriers within the multicarrier signal.” 8:29-33.</p> <p>“The frequency information provided by the microcontroller 142 is used by the predistorter 108 in the third embodiment to reconstruct the composite signal using any appropriate method. The methods require frequency information. One example is the inverse fast fourier transform technique which creates a spectral representation of the signal sampled in the time domain.” 8:37-43.</p> <p>“In the embodiments where the composite signal is predistorted, the combiner output consists of amplitude words, the correction occurring by adjusting the magnitude of the words. Nonlinearities in the amplifier output could be compensated by correcting the magnitude of the combiner output words with an inverse function. The correction may thus be dependent on the particular combiner output. This might occur by indexing a look-up table with the combiner output word and outputting the respective contents to the digital to analogue converter.” 9:18-27.</p>

Claim No.	'204 Patent	Exemplary Evidence of Anticipation and/or Obviousness
		<p style="text-align: center;">Fig.4.</p> <p style="text-align: center;">Fig. 4.</p>

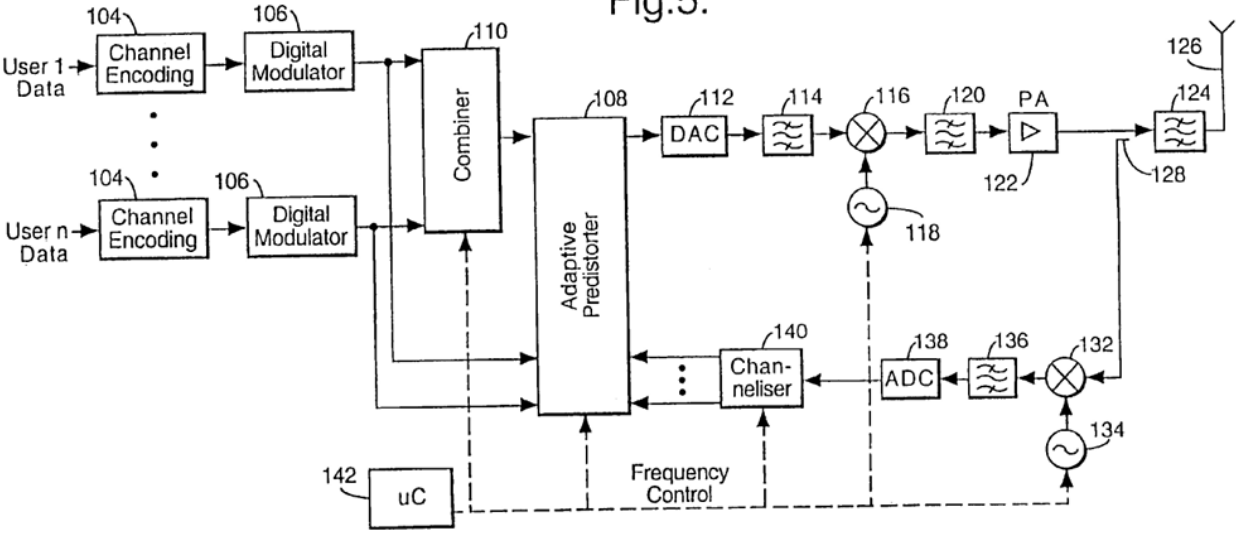
Claim No.	'204 Patent	Exemplary Evidence of Anticipation and/or Obviousness
		<p style="text-align: center;">Fig.5.</p>  <p style="text-align: center;">Fig. 5.</p>

Claim No.	'204 Patent	Exemplary Evidence of Anticipation and/or Obviousness
-----------	-------------	---

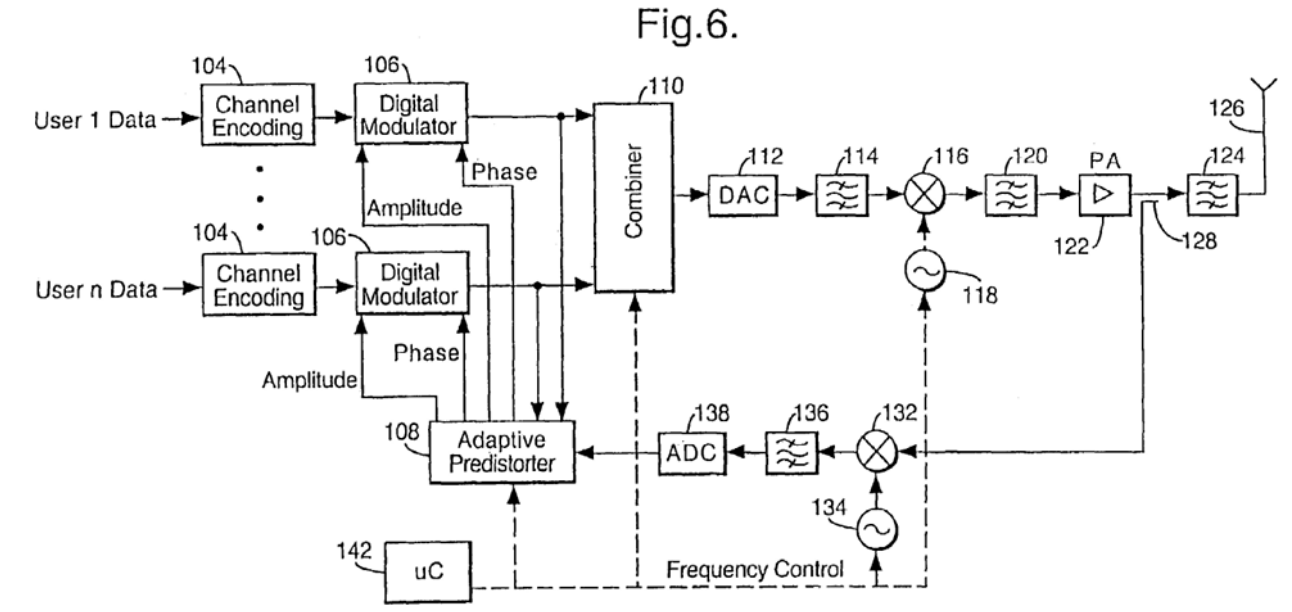
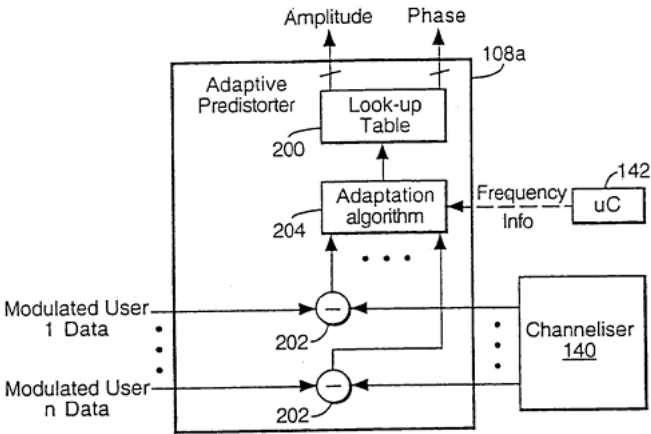
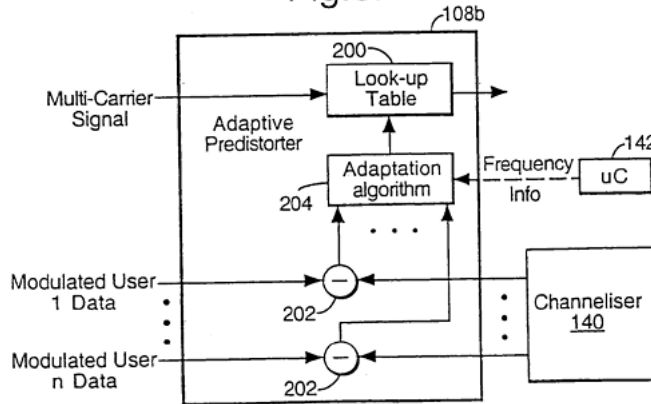
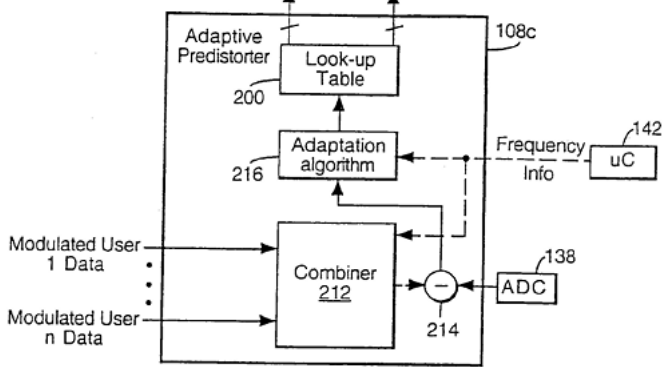
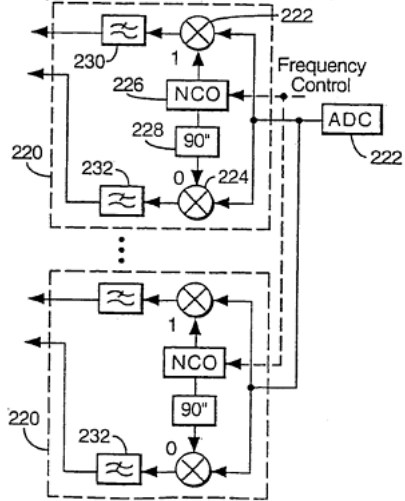

Fig. 6.

Claim No.	'204 Patent	Exemplary Evidence of Anticipation and/or Obviousness
		<p data-bbox="1144 188 1245 225">Fig.7.</p>  <p data-bbox="1144 788 1245 825">Fig.8.</p>  <p data-bbox="837 1286 1012 1323">Figs. 7 and 8.</p>

Claim No.	'204 Patent	Exemplary Evidence of Anticipation and/or Obviousness
		<p data-bbox="996 183 1276 223">Fig.9. Amplitude Phase</p>  <p data-bbox="974 678 1120 718">Fig.10.</p> <p data-bbox="974 718 1332 742">Principle of an NCO-Based Channeliser</p>  <p data-bbox="840 1284 985 1324">Figs. 9-10.</p>

Claim No.	'204 Patent	Exemplary Evidence of Anticipation and/or Obviousness
8	<p>The transmitter of claim 2, wherein said signal observation feedback loop further comprises:</p> <p>a single subsampling-based receiver to down-convert samples output from a concurrent multi-band transmitter.</p>	<p>Posti discloses and/or renders obvious the transmitter of claim 2, wherein said signal observation feedback loop further comprises: a single subsampling-based receiver to down-convert samples output from a concurrent multi-band transmitter.</p> <p><i>See claim 2, supra, which is incorporated by reference herein.</i></p> <p><i>See, e.g.,</i></p> <p>“A multi frequency carrier transmitter comprises input means for receiving a plurality of different digital signals to be transmitted. The different signals are to be transmitted on different carrier frequencies. Amplifier means receive a composite signal comprising the different signals at the respective carrier frequencies and amplify the composite signal. Predistortion means predistort the plurality of digital signals prior to amplification of the composite signal by the amplification means. The predistortion provided by the predistortion means is subsequently altered in dependence on the difference between the input signals and the output at the amplifier means.” Abstract.</p> <p>“The present invention relates to a transmitter and a method of transmitting and in particular, but not exclusively, for use in a telecommunications network.”</p> <p>“The output of each transmit path 14–14' is connected to the input of a combiner 22 which combines the signals from each path 14–14' to provide a multicarrier signal. The output of the combiner 22 is connected to an antenna 24 which transmits the multicarrier signal containing each of the N different channels to the terminals in the cell served by the base station.” 1:53-59.</p> <p>“According to one aspect of the present invention, there is provided a multi frequency carrier transmitter comprising input means for receiving a plurality of different digital signals to be transmitted, said different signals to be transmitted on different carrier frequencies; amplifier means for receiving a composite signal comprising said different signals at the respective carrier frequencies and amplifying said composite signal; and predistortion means for predistorting said plurality of digital signals prior to amplification of the composite signal by said amplification means, said predistortion provided by said predistortion means being subsequently altered in</p>

Claim No.	'204 Patent	Exemplary Evidence of Anticipation and/or Obviousness
		<p>dependence on the difference between said input signals and the output at said amplifier means.” 2:43-55.</p> <p>“Accordingly, embodiments of the present invention provide a multi carrier transmitter which is able to deal with the problems of nonlinearity by using predistortion. The predistortion can be implemented more simply than the feedback method discussed in the prior art.” 2:55-60.</p> <p>“The output of the second bandpass filter 120 is input to the power amplifier 122 which amplifies the received input. The output of the amplifier 122 is input to a third bandpass filter 124 which is arranged to filter out any signal components introduced by the amplifier 122 which fall outside the radio frequency band of the signals to be transmitted. The output of the third bandpass filter 124 is passed to an antenna 126 which transmits the signals to the terminals in the cell associated with the base station.” 5:41-49.</p> <p>“The input means are preferably arranged to separately receive each of the different signals. Combiner means are preferably provided between the input means and the amplifier means for combining said plurality of different signals to provide a composite signal. This may be the composite signal input to the amplifier means or may be a composite signal at a lower, intermediate frequency. In the latter case, that composite signal at a lower frequency would be upconverted to provide the composite signal input to the amplifier means.” 2:61-3:3.</p> <p>“A feedback path may be arranged between the amplifying means and the predistorting means. Preferably, the predistorting means is arranged to compare the output from the amplifying means from the feedback path with the signals received by the receiving means and to provide, if necessary, at least one new predistortion value to be applied to at least one subsequent signal received by the receiving means. In this way, the predistorting means can adapt to changes in the operating conditions of the amplifier means.” 3:14-21.</p> <p>“Preferably, means are provided in the feedback path for separating the output of the amplifying means into a plurality of different signals. The predistorting means is preferably arranged to compare each of the separated signals with the corresponding signals received from the input means and to determine if the at least one predistortion value needs to be altered.” 3:23-29.</p>

Claim No.	'204 Patent	Exemplary Evidence of Anticipation and/or Obviousness
		<p>“Alternatively, the predistorting means is arranged to compare the composite signal from the amplifying means with a plurality of different signals to provide, if necessary, the at least one new predistortion value.” 3:30-33.</p> <p>“The amplifier means is preferably a nonlinear amplifier. The predistortion means is preferably arranged to compensate for the nonlinearity of the phase and/or amplitude of the output of the amplifier.” 3:45-58.</p> <p>“A digital to analogue converter may be provided for converting the plurality of signals to analogue form before said signals are amplified by said amplifier means.</p> <p>The transmitter is preferably incorporated in a base station or alternatively in a mobile station.</p> <p>According to a second aspect of the present invention, there is provided a multi carrier frequency transmission method comprising the steps of receiving a plurality of different digital signals to be transmitted, said different signals to be transmitted on different carrier frequencies; combining said plurality of different signals to provide a composite signal comprising the different signals at the respective carrier frequencies; and amplifying said composite signal, wherein the method further comprises the steps of: predistorting the plurality of different digital signals prior to amplification of the composite signal by the amplification means; and altering the predistortion applied to subsequent signals in dependence on the difference between said different signals and the amplified signal.” 3:49-67.</p> <p>“Reference will now be made to FIG. 4 which shows a first embodiment of the present invention. In particular, the transmit part 102 of the base station 100 is shown. The base station 100 is in a cellular system of the type shown in FIG. 1.” 4:30-34.</p> <p>“The transmit part 102 of the base station 100 comprises N channel encoders 104 where N is the number of different frequencies on which the base station 100 will transmit signals. Each channel encoder 104 receives the data to be transmitted on the particular frequency associated with the given channel encoder 104. The data is placed in a suitable form for transmission. This may include digitising the data, encoding the data, interleaving the data and/or any other step required to be carried out. As mentioned hereinbefore, each channel is on a different frequency after the</p>

Claim No.	'204 Patent	Exemplary Evidence of Anticipation and/or Obviousness
		<p>modulator. The signals output by the channel encoders 104 are in digital form and are at a baseband frequency. Coding, interleaving etc is performed on the digital baseband signals.” 4:35-36.</p> <p>“The output of each channel encoder 104 is input to a respective digital modulator 106. Each digital modulator 106 also receives two outputs from the adaptive predistorter 108. The first output from the predistorter 108 provides one or more amplitude coefficients which are used to predistort the signal which is output by the digital modulator to compensate for the non linearity of an amplifier 122 with respect to amplitude. The second output from the predistorter 108 provides one or more phase coefficients which are used to predistort the signal which is output by the modulator 106 to compensate for phase distortion provided by the amplifier 122. The amplifier 122 will be described in more detail hereinafter.” 4:48-60.</p> <p>“The predistortion to compensate for the phase and amplitude distortion introduced by the amplifier 122 can take place at the same time. The predistortion can be performed during or more preferably after the modulation has been carried out by the modulator 106.” 5:6-10.</p> <p>“The output of the second bandpass filter 120 is input to the power amplifier 122 which amplifies the received input. The output of the amplifier 122 is input to a third bandpass filter 124 which is arranged to filter out any signal components introduced by the amplifier 122 which fall outside the radio frequency band of the signals to be transmitted. The output of the third bandpass filter 124 is passed to an antenna 126 which transmits the signals to the terminals in the cell associated with the base station.” 5:41-49.</p> <p>“The adaptive predistorter 108 does not, as in the first embodiment, have outputs connected to the digital modulators 106. The output of the combiner 110 is connected to the input of the predistorter 108. The output of the predistorter 108 is connected to the input of the digital to analogue convertor. The predistorter 108 thus predistorts the multicarrier output of the combiner 110 and outputs a predistorted multicarrier signal. The feedback path is the same in the first and second embodiments and accordingly the predistorter 108 operates in a similar manner to that shown in the first embodiment. However, phase correction is not applied and the amplitude correction is the</p>

Claim No.	'204 Patent	Exemplary Evidence of Anticipation and/or Obviousness
		<p>same for all frequencies. This solution is simple but may not provide the required performance in all cases.” 7:39-52.</p> <p>“Reference will now be made to FIG. 8 which shows a second predistorter 108 b which can be used in the second embodiment shown in FIG. 5. This second predistorter 108 comprises n subtractors 208 each of which receives an output from a respective one of the digital modulators. Each subtracter 208 also receives a corresponding input from the channelizer 140 as in the first embodiment. Each subtracter 208 thus receives two modulated signals. The two signals received by each subtracter 208 are subtracted one from the other to generate a difference signal. This output difference signal is input to the adaption algorithm block 204 which is the same as discussed in relation to the first predistorter of FIG. 7. As with the first predistorter of FIG. 7, the adaption algorithm block 204 also receives an input from the microcontroller 142 with information concerning the frequency. The adaption algorithm block 204 provides amplitude coefficients on its output which are output to the look-up table 200. Unlike the embodiment shown in FIG. 7, the look-up table receives the multicarrier signal from the combiner 110 which defines an address in the look-up table. Accordingly, the multicarrier signal is modified in accordance with the amplitude values from the look-up table and output to the digital to analogue convertor 112.” 7:53-8:8.</p> <p>“Reference is now made to FIG. 10 which shows a possible construction of the channeliser 140. The channeliser comprises n blocks 220, with one block provided for each frequency. Each block of the channeliser 220 comprises an input for receiving the output of the analogue to digital converter 138 and a frequency control signal from the microcontroller 142. The output from the analogue to digital converter 138 is input to first and second multipliers 222 and 224. The first multiplier 222 produces the I or in-band, component of the input signal whilst the second multiplier 224 produces the Q, or quadrature-phase component of the input signal. Each of the multipliers 222 and 224 receives a frequency from the numerically controlled oscillator 226. The frequency of the oscillator 226 is controlled by the frequency control input. The output of the oscillator 226 is connected directly to one of the multipliers 222 whilst the output for the second multipliers 224 is connected to a phase shifter 228 which shifts the phase of the output signal from the oscillator 226 by 90°. The phase shifted output signal of the oscillator 226 is input to the second multipliers 224.” 8:9-28.</p>

Claim No.	'204 Patent	Exemplary Evidence of Anticipation and/or Obviousness
		<p>“The output of each of the first and second multipliers 222 and 224 are connected to filters 230 and 232 which are arranged to filter out signal components introduced by the respective multipliers as well as other carriers within the multicarrier signal.” 8:29-33.</p> <p>“The frequency information provided by the microcontroller 142 is used by the predistorter 108 in the third embodiment to reconstruct the composite signal using any appropriate method. The methods require frequency information. One example is the inverse fast fourier transform technique which creates a spectral representation of the signal sampled in the time domain.” 8:37-43.</p> <p>“In the embodiments where the composite signal is predistorted, the combiner output consists of amplitude words, the correction occurring by adjusting the magnitude of the words. Nonlinearities in the amplifier output could be compensated by correcting the magnitude of the combiner output words with an inverse function. The correction may thus be dependent on the particular combiner output. This might occur by indexing a look-up table with the combiner output word and outputting the respective contents to the digital to analogue converter.” 9:18-27.</p>

Claim No.	'204 Patent	Exemplary Evidence of Anticipation and/or Obviousness
		<p style="text-align: center;">Fig.4.</p> <p style="text-align: center;">Fig. 4.</p>

Claim No.	'204 Patent	Exemplary Evidence of Anticipation and/or Obviousness
		<p style="text-align: center;">Fig.5.</p> <p style="text-align: center;">Fig. 5.</p>

Claim No.	'204 Patent	Exemplary Evidence of Anticipation and/or Obviousness
-----------	-------------	---

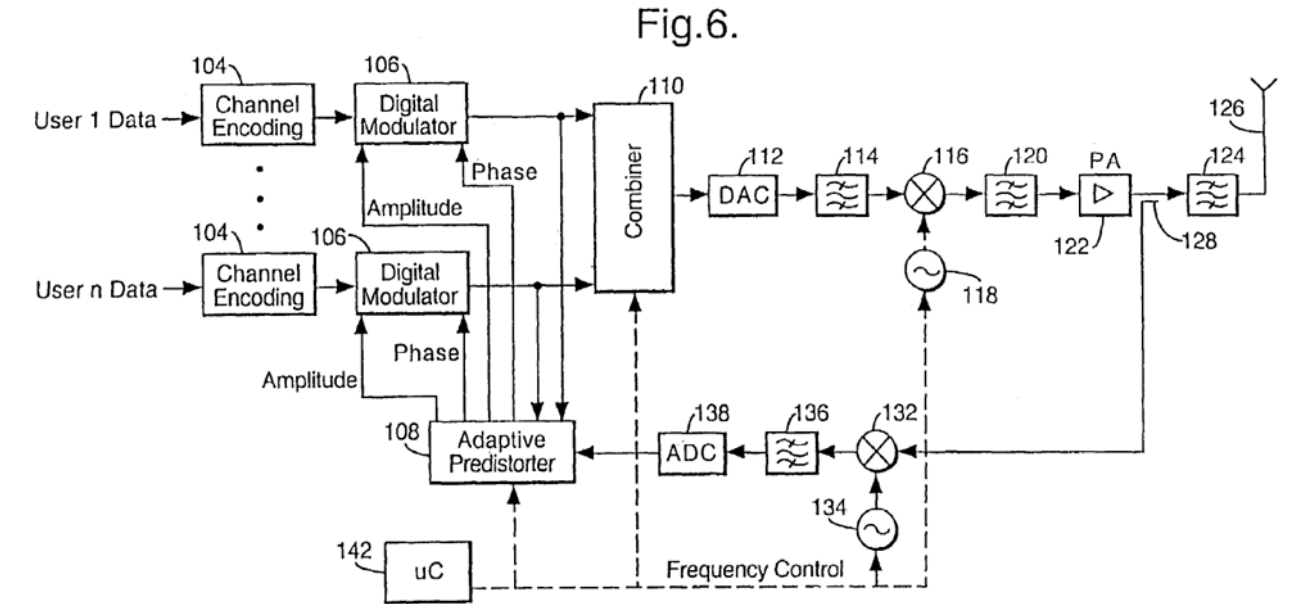
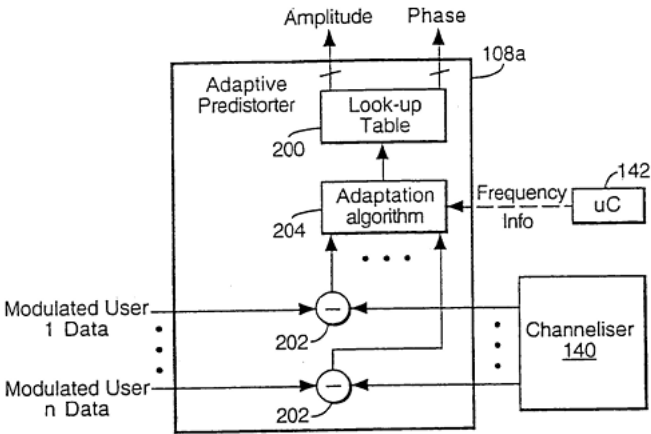
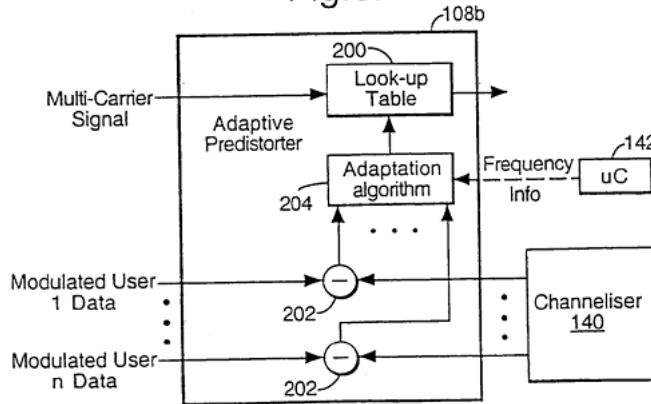
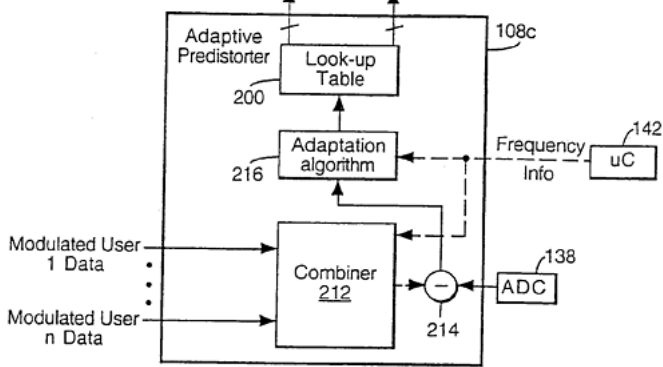
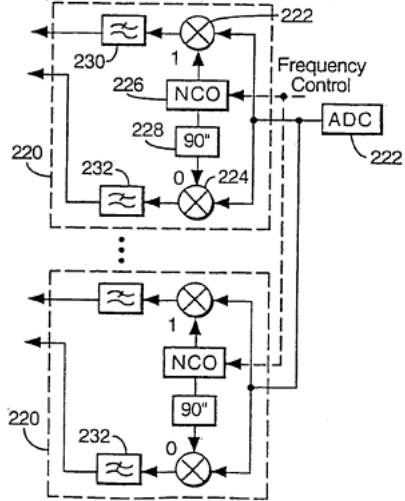

Fig. 6.

Claim No.	'204 Patent	Exemplary Evidence of Anticipation and/or Obviousness
		<p data-bbox="1144 188 1245 225">Fig.7.</p>  <p data-bbox="1144 788 1245 825">Fig.8.</p>  <p data-bbox="837 1286 1010 1323">Figs. 7 and 8.</p>

Claim No.	'204 Patent	Exemplary Evidence of Anticipation and/or Obviousness
		<p data-bbox="996 183 1288 223">Fig.9. Amplitude Phase</p>  <p data-bbox="974 678 1097 718">Fig.10.</p> <p data-bbox="974 718 1332 742">Principle of an NCO-Based Channeliser</p>  <p data-bbox="840 1284 985 1324">Figs. 9-10.</p>

Claim No.	'204 Patent	Exemplary Evidence of Anticipation and/or Obviousness
9	<p>The transmitter of claim 8, wherein said single subsampling-based receiver further comprises:</p> <p>an RF filter;</p> <p>a track and hold (T&H) block; and</p> <p>an analog-to-digital converter (ADC).</p>	<p>Posti discloses and/or renders obvious the transmitter of claim 8, wherein said single subsampling-based receiver further comprises: an RF filter; a track and hold (T&H) block; and an analog-to-digital converter (ADC).</p> <p><i>See</i> claim 8, <i>supra</i>, which is incorporated by reference herein.</p> <p><i>See, e.g.,</i></p> <p>“A multi frequency carrier transmitter comprises input means for receiving a plurality of different digital signals to be transmitted. The different signals are to be transmitted on different carrier frequencies. Amplifier means receive a composite signal comprising the different signals at the respective carrier frequencies and amplify the composite signal. Predistortion means predistort the plurality of digital signals prior to amplification of the composite signal by the amplification means. The predistortion provided by the predistortion means is subsequently altered in dependence on the difference between the input signals and the output at the amplifier means.” Abstract.</p> <p>“The present invention relates to a transmitter and a method of transmitting and in particular, but not exclusively, for use in a telecommunications network.”</p> <p>“The output of each transmit path 14–14' is connected to the input of a combiner 22 which combines the signals from each path 14–14' to provide a multicarrier signal. The output of the combiner 22 is connected to an antenna 24 which transmits the multicarrier signal containing each of the N different channels to the terminals in the cell served by the base station.” 1:53-59.</p> <p>“According to one aspect of the present invention, there is provided a multi frequency carrier transmitter comprising input means for receiving a plurality of different digital signals to be transmitted, said different signals to be transmitted on different carrier frequencies; amplifier means for receiving a composite signal comprising said different signals at the respective carrier frequencies and amplifying said composite signal; and predistortion means for predistorting said plurality of digital signals prior to amplification of the composite signal by said amplification means, said predistortion provided by said predistortion means being subsequently altered in</p>

Claim No.	'204 Patent	Exemplary Evidence of Anticipation and/or Obviousness
		<p>dependence on the difference between said input signals and the output at said amplifier means.” 2:43-55.</p> <p>“Accordingly, embodiments of the present invention provide a multi carrier transmitter which is able to deal with the problems of nonlinearity by using predistortion. The predistortion can be implemented more simply than the feedback method discussed in the prior art.” 2:55-60.</p> <p>“The output of the second bandpass filter 120 is input to the power amplifier 122 which amplifies the received input. The output of the amplifier 122 is input to a third bandpass filter 124 which is arranged to filter out any signal components introduced by the amplifier 122 which fall outside the radio frequency band of the signals to be transmitted. The output of the third bandpass filter 124 is passed to an antenna 126 which transmits the signals to the terminals in the cell associated with the base station.” 5:41-49.</p> <p>“The input means are preferably arranged to separately receive each of the different signals. Combiner means are preferably provided between the input means and the amplifier means for combining said plurality of different signals to provide a composite signal. This may be the composite signal input to the amplifier means or may be a composite signal at a lower, intermediate frequency. In the latter case, that composite signal at a lower frequency would be upconverted to provide the composite signal input to the amplifier means.” 2:61-3:3.</p> <p>“A feedback path may be arranged between the amplifying means and the predistorting means. Preferably, the predistorting means is arranged to compare the output from the amplifying means from the feedback path with the signals received by the receiving means and to provide, if necessary, at least one new predistortion value to be applied to at least one subsequent signal received by the receiving means. In this way, the predistorting means can adapt to changes in the operating conditions of the amplifier means.” 3:14-21.</p> <p>“Preferably, means are provided in the feedback path for separating the output of the amplifying means into a plurality of different signals. The predistorting means is preferably arranged to compare each of the separated signals with the corresponding signals received from the input means and to determine if the at least one predistortion value needs to be altered.” 3:23-29.</p>

Claim No.	'204 Patent	Exemplary Evidence of Anticipation and/or Obviousness
		<p>“Alternatively, the predistorting means is arranged to compare the composite signal from the amplifying means with a plurality of different signals to provide, if necessary, the at least one new predistortion value.” 3:30-33.</p> <p>“The amplifier means is preferably a nonlinear amplifier. The predistortion means is preferably arranged to compensate for the nonlinearity of the phase and/or amplitude of the output of the amplifier.” 3:45-58.</p> <p>“A digital to analogue converter may be provided for converting the plurality of signals to analogue form before said signals are amplified by said amplifier means.</p> <p>The transmitter is preferably incorporated in a base station or alternatively in a mobile station.</p> <p>According to a second aspect of the present invention, there is provided a multi carrier frequency transmission method comprising the steps of receiving a plurality of different digital signals to be transmitted, said different signals to be transmitted on different carrier frequencies; combining said plurality of different signals to provide a composite signal comprising the different signals at the respective carrier frequencies; and amplifying said composite signal, wherein the method further comprises the steps of: predistorting the plurality of different digital signals prior to amplification of the composite signal by the amplification means; and altering the predistortion applied to subsequent signals in dependence on the difference between said different signals and the amplified signal.” 3:49-67.</p> <p>“Reference will now be made to FIG. 4 which shows a first embodiment of the present invention. In particular, the transmit part 102 of the base station 100 is shown. The base station 100 is in a cellular system of the type shown in FIG. 1.” 4:30-34.</p> <p>“The transmit part 102 of the base station 100 comprises N channel encoders 104 where N is the number of different frequencies on which the base station 100 will transmit signals. Each channel encoder 104 receives the data to be transmitted on the particular frequency associated with the given channel encoder 104. The data is placed in a suitable form for transmission. This may include digitising the data, encoding the data, interleaving the data and/or any other step required to be carried out. As mentioned hereinbefore, each channel is on a different frequency after the</p>

Claim No.	'204 Patent	Exemplary Evidence of Anticipation and/or Obviousness
		<p>modulator. The signals output by the channel encoders 104 are in digital form and are at a baseband frequency. Coding, interleaving etc is performed on the digital baseband signals.” 4:35-36.</p> <p>“The output of each channel encoder 104 is input to a respective digital modulator 106. Each digital modulator 106 also receives two outputs from the adaptive predistorter 108. The first output from the predistorter 108 provides one or more amplitude coefficients which are used to predistort the signal which is output by the digital modulator to compensate for the non linearity of an amplifier 122 with respect to amplitude. The second output from the predistorter 108 provides one or more phase coefficients which are used to predistort the signal which is output by the modulator 106 to compensate for phase distortion provided by the amplifier 122. The amplifier 122 will be described in more detail hereinafter.” 4:48-60.</p> <p>“The predistortion to compensate for the phase and amplitude distortion introduced by the amplifier 122 can take place at the same time. The predistortion can be performed during or more preferably after the modulation has been carried out by the modulator 106.” 5:6-10.</p> <p>“The output of the second bandpass filter 120 is input to the power amplifier 122 which amplifies the received input. The output of the amplifier 122 is input to a third bandpass filter 124 which is arranged to filter out any signal components introduced by the amplifier 122 which fall outside the radio frequency band of the signals to be transmitted. The output of the third bandpass filter 124 is passed to an antenna 126 which transmits the signals to the terminals in the cell associated with the base station.” 5:41-49.</p> <p>“The adaptive predistorter 108 does not, as in the first embodiment, have outputs connected to the digital modulators 106. The output of the combiner 110 is connected to the input of the predistorter 108. The output of the predistorter 108 is connected to the input of the digital to analogue convertor. The predistorter 108 thus predistorts the multicarrier output of the combiner 110 and outputs a predistorted multicarrier signal. The feedback path is the same in the first and second embodiments and accordingly the predistorter 108 operates in a similar manner to that shown in the first embodiment. However, phase correction is not applied and the amplitude correction is the</p>

Claim No.	'204 Patent	Exemplary Evidence of Anticipation and/or Obviousness
		<p>same for all frequencies. This solution is simple but may not provide the required performance in all cases.” 7:39-52.</p> <p>“Reference will now be made to FIG. 8 which shows a second predistorter 108 b which can be used in the second embodiment shown in FIG. 5. This second predistorter 108 comprises n subtractors 208 each of which receives an output from a respective one of the digital modulators. Each subtractor 208 also receives a corresponding input from the channelizer 140 as in the first embodiment. Each subtractor 208 thus receives two modulated signals. The two signals received by each subtractor 208 are subtracted one from the other to generate a difference signal. This output difference signal is input to the adaption algorithm block 204 which is the same as discussed in relation to the first predistorter of FIG. 7. As with the first predistorter of FIG. 7, the adaption algorithm block 204 also receives an input from the microcontroller 142 with information concerning the frequency. The adaption algorithm block 204 provides amplitude coefficients on its output which are output to the look-up table 200. Unlike the embodiment shown in FIG. 7, the look-up table receives the multicarrier signal from the combiner 110 which defines an address in the look-up table. Accordingly, the multicarrier signal is modified in accordance with the amplitude values from the look-up table and output to the digital to analogue convertor 112.” 7:53-8:8.</p> <p>“Reference is now made to FIG. 10 which shows a possible construction of the channeliser 140. The channeliser comprises n blocks 220, with one block provided for each frequency. Each block of the channeliser 220 comprises an input for receiving the output of the analogue to digital converter 138 and a frequency control signal from the microcontroller 142. The output from the analogue to digital converter 138 is input to first and second multipliers 222 and 224. The first multiplier 222 produces the I or in-band, component of the input signal whilst the second multiplier 224 produces the Q, or quadrature-phase component of the input signal. Each of the multipliers 222 and 224 receives a frequency from the numerically controlled oscillator 226. The frequency of the oscillator 226 is controlled by the frequency control input. The output of the oscillator 226 is connected directly to one of the multipliers 222 whilst the output for the second multipliers 224 is connected to a phase shifter 228 which shifts the phase of the output signal from the oscillator 226 by 90°. The phase shifted output signal of the oscillator 226 is input to the second multipliers 224.” 8:9-28.</p>

Claim No.	'204 Patent	Exemplary Evidence of Anticipation and/or Obviousness
		<p>“The output of each of the first and second multipliers 222 and 224 are connected to filters 230 and 232 which are arranged to filter out signal components introduced by the respective multipliers as well as other carriers within the multicarrier signal.” 8:29-33.</p> <p>“The frequency information provided by the microcontroller 142 is used by the predistorter 108 in the third embodiment to reconstruct the composite signal using any appropriate method. The methods require frequency information. One example is the inverse fast fourier transform technique which creates a spectral representation of the signal sampled in the time domain.” 8:37-43.</p> <p>“In the embodiments where the composite signal is predistorted, the combiner output consists of amplitude words, the correction occurring by adjusting the magnitude of the words. Nonlinearities in the amplifier output could be compensated by correcting the magnitude of the combiner output words with an inverse function. The correction may thus be dependent on the particular combiner output. This might occur by indexing a look-up table with the combiner output word and outputting the respective contents to the digital to analogue converter.” 9:18-27.</p>

Claim No.	'204 Patent	Exemplary Evidence of Anticipation and/or Obviousness
		<p style="text-align: center;">Fig.4.</p> <p style="text-align: center;">Fig. 4.</p>

Claim No.	'204 Patent	Exemplary Evidence of Anticipation and/or Obviousness
		<p style="text-align: center;">Fig.5.</p> <p style="text-align: center;">Fig. 5.</p>

Claim No.	'204 Patent	Exemplary Evidence of Anticipation and/or Obviousness
-----------	-------------	---

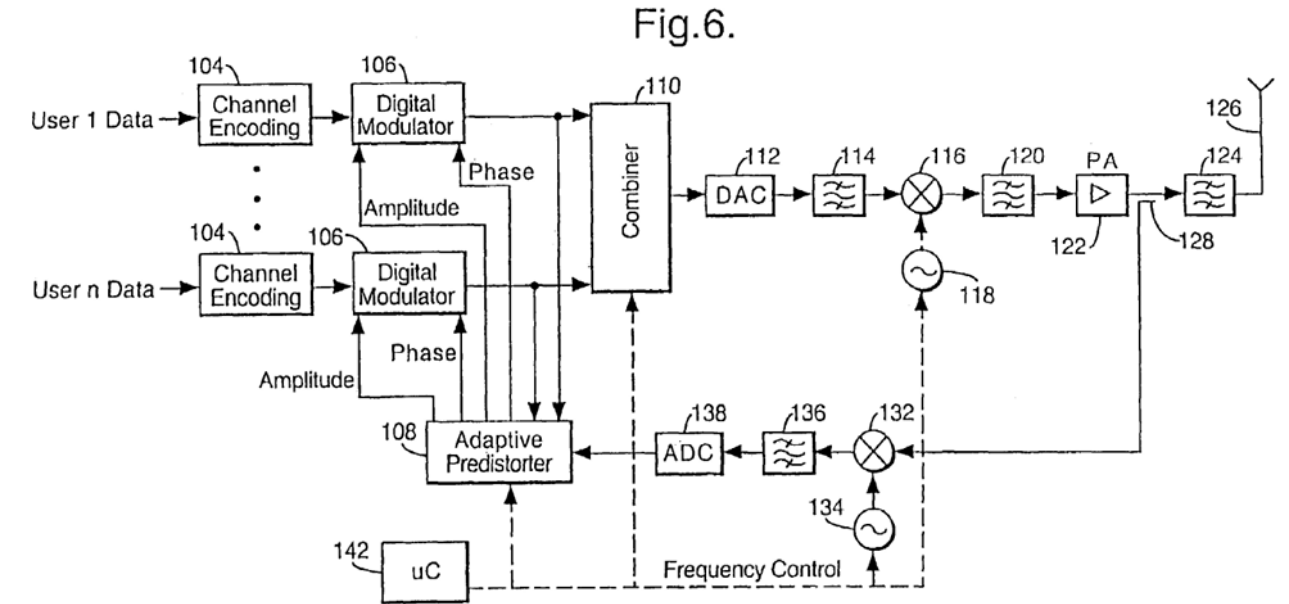
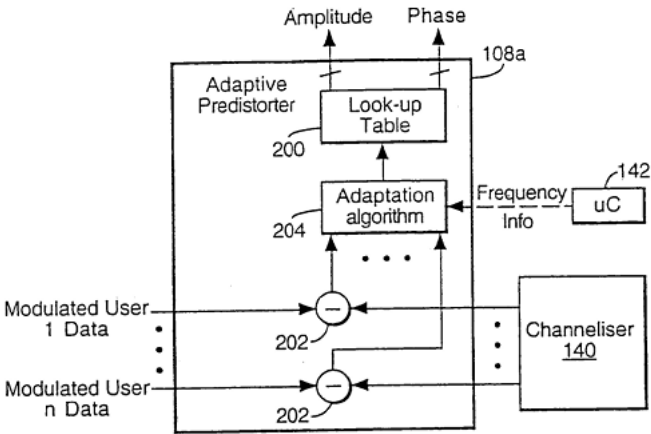
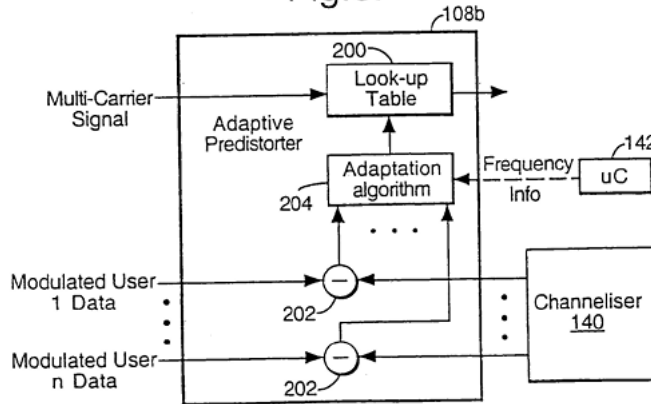
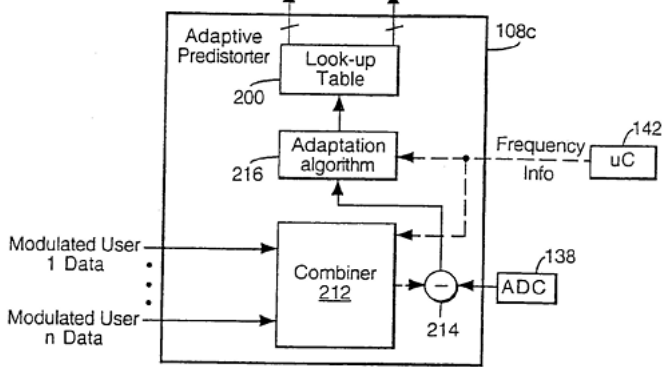
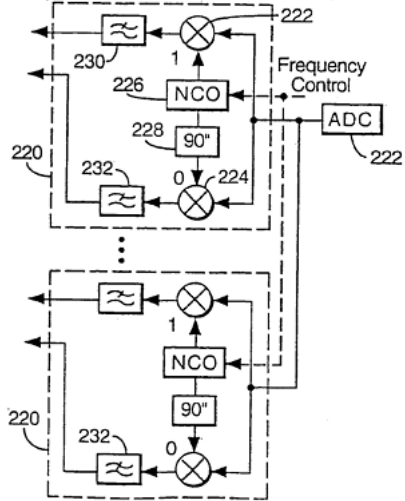

Fig. 6.

Claim No.	'204 Patent	Exemplary Evidence of Anticipation and/or Obviousness
		<p data-bbox="1144 188 1245 225">Fig.7.</p>  <p data-bbox="1144 788 1245 825">Fig.8.</p>  <p data-bbox="837 1286 1010 1323">Figs. 7 and 8.</p>

Claim No.	'204 Patent	Exemplary Evidence of Anticipation and/or Obviousness
		<p data-bbox="996 183 1276 223">Fig.9. Amplitude Phase</p>  <p data-bbox="974 678 1120 718">Fig.10.</p> <p data-bbox="974 718 1332 742">Principle of an NCO-Based Channeliser</p>  <p data-bbox="840 1284 985 1324">Figs. 9-10.</p>

Claim No.	'204 Patent	Exemplary Evidence of Anticipation and/or Obviousness
10	The transmitter of claim 1, wherein the subsampling frequency is greater than two times a signal bandwidth of the modulated concurrent multi-band signals.	<p>Posti discloses and/or renders obvious the transmitter of claim 1, wherein the subsampling frequency is greater than two times a signal bandwidth of the modulated concurrent multi-band signals.</p> <p><i>See</i> claim 1, <i>supra</i>, which is incorporated by reference herein.</p> <p><i>See, e.g.,</i></p> <p>“A multi frequency carrier transmitter comprises input means for receiving a plurality of different digital signals to be transmitted. The different signals are to be transmitted on different carrier frequencies. Amplifier means receive a composite signal comprising the different signals at the respective carrier frequencies and amplify the composite signal. Predistortion means predistort the plurality of digital signals prior to amplification of the composite signal by the amplification means. The predistortion provided by the predistortion means is subsequently altered in dependence on the difference between the input signals and the output at the amplifier means.” Abstract.</p> <p>“The present invention relates to a transmitter and a method of transmitting and in particular, but not exclusively, for use in a telecommunications network.”</p> <p>“The output of each transmit path 14–14' is connected to the input of a combiner 22 which combines the signals from each path 14–14' to provide a multicarrier signal. The output of the combiner 22 is connected to an antenna 24 which transmits the multicarrier signal containing each of the N different channels to the terminals in the cell served by the base station.” 1:53-59.</p> <p>“According to one aspect of the present invention, there is provided a multi frequency carrier transmitter comprising input means for receiving a plurality of different digital signals to be transmitted, said different signals to be transmitted on different carrier frequencies; amplifier means for receiving a composite signal comprising said different signals at the respective carrier frequencies and amplifying said composite signal; and predistortion means for predistorting said plurality of digital signals prior to amplification of the composite signal by said amplification means, said predistortion provided by said predistortion means being subsequently altered in</p>

Claim No.	'204 Patent	Exemplary Evidence of Anticipation and/or Obviousness
		<p>dependence on the difference between said input signals and the output at said amplifier means.” 2:43-55.</p> <p>“Accordingly, embodiments of the present invention provide a multi carrier transmitter which is able to deal with the problems of nonlinearity by using predistortion. The predistortion can be implemented more simply than the feedback method discussed in the prior art.” 2:55-60.</p> <p>“The output of the second bandpass filter 120 is input to the power amplifier 122 which amplifies the received input. The output of the amplifier 122 is input to a third bandpass filter 124 which is arranged to filter out any signal components introduced by the amplifier 122 which fall outside the radio frequency band of the signals to be transmitted. The output of the third bandpass filter 124 is passed to an antenna 126 which transmits the signals to the terminals in the cell associated with the base station.” 5:41-49.</p> <p>“The input means are preferably arranged to separately receive each of the different signals. Combiner means are preferably provided between the input means and the amplifier means for combining said plurality of different signals to provide a composite signal. This may be the composite signal input to the amplifier means or may be a composite signal at a lower, intermediate frequency. In the latter case, that composite signal at a lower frequency would be upconverted to provide the composite signal input to the amplifier means.” 2:61-3:3.</p> <p>“A feedback path may be arranged between the amplifying means and the predistorting means. Preferably, the predistorting means is arranged to compare the output from the amplifying means from the feedback path with the signals received by the receiving means and to provide, if necessary, at least one new predistortion value to be applied to at least one subsequent signal received by the receiving means. In this way, the predistorting means can adapt to changes in the operating conditions of the amplifier means.” 3:14-21.</p> <p>“Preferably, means are provided in the feedback path for separating the output of the amplifying means into a plurality of different signals. The predistorting means is preferably arranged to compare each of the separated signals with the corresponding signals received from the input means and to determine if the at least one predistortion value needs to be altered.” 3:23-29.</p>

Claim No.	'204 Patent	Exemplary Evidence of Anticipation and/or Obviousness
		<p>“Alternatively, the predistorting means is arranged to compare the composite signal from the amplifying means with a plurality of different signals to provide, if necessary, the at least one new predistortion value.” 3:30-33.</p> <p>“The amplifier means is preferably a nonlinear amplifier. The predistortion means is preferably arranged to compensate for the nonlinearity of the phase and/or amplitude of the output of the amplifier.” 3:45-58.</p> <p>“A digital to analogue converter may be provided for converting the plurality of signals to analogue form before said signals are amplified by said amplifier means.</p> <p>The transmitter is preferably incorporated in a base station or alternatively in a mobile station.</p> <p>According to a second aspect of the present invention, there is provided a multi carrier frequency transmission method comprising the steps of receiving a plurality of different digital signals to be transmitted, said different signals to be transmitted on different carrier frequencies; combining said plurality of different signals to provide a composite signal comprising the different signals at the respective carrier frequencies; and amplifying said composite signal, wherein the method further comprises the steps of: predistorting the plurality of different digital signals prior to amplification of the composite signal by the amplification means; and altering the predistortion applied to subsequent signals in dependence on the difference between said different signals and the amplified signal.” 3:49-67.</p> <p>“Reference will now be made to FIG. 4 which shows a first embodiment of the present invention. In particular, the transmit part 102 of the base station 100 is shown. The base station 100 is in a cellular system of the type shown in FIG. 1.” 4:30-34.</p> <p>“The transmit part 102 of the base station 100 comprises N channel encoders 104 where N is the number of different frequencies on which the base station 100 will transmit signals. Each channel encoder 104 receives the data to be transmitted on the particular frequency associated with the given channel encoder 104. The data is placed in a suitable form for transmission. This may include digitising the data, encoding the data, interleaving the data and/or any other step required to be carried out. As mentioned hereinbefore, each channel is on a different frequency after the</p>

Claim No.	'204 Patent	Exemplary Evidence of Anticipation and/or Obviousness
		<p>modulator. The signals output by the channel encoders 104 are in digital form and are at a baseband frequency. Coding, interleaving etc is performed on the digital baseband signals.” 4:35-36.</p> <p>“The output of each channel encoder 104 is input to a respective digital modulator 106. Each digital modulator 106 also receives two outputs from the adaptive predistorter 108. The first output from the predistorter 108 provides one or more amplitude coefficients which are used to predistort the signal which is output by the digital modulator to compensate for the non linearity of an amplifier 122 with respect to amplitude. The second output from the predistorter 108 provides one or more phase coefficients which are used to predistort the signal which is output by the modulator 106 to compensate for phase distortion provided by the amplifier 122. The amplifier 122 will be described in more detail hereinafter.” 4:48-60.</p> <p>“The predistortion to compensate for the phase and amplitude distortion introduced by the amplifier 122 can take place at the same time. The predistortion can be performed during or more preferably after the modulation has been carried out by the modulator 106.” 5:6-10.</p> <p>“The output of the second bandpass filter 120 is input to the power amplifier 122 which amplifies the received input. The output of the amplifier 122 is input to a third bandpass filter 124 which is arranged to filter out any signal components introduced by the amplifier 122 which fall outside the radio frequency band of the signals to be transmitted. The output of the third bandpass filter 124 is passed to an antenna 126 which transmits the signals to the terminals in the cell associated with the base station.” 5:41-49.</p> <p>“The adaptive predistorter 108 does not, as in the first embodiment, have outputs connected to the digital modulators 106. The output of the combiner 110 is connected to the input of the predistorter 108. The output of the predistorter 108 is connected to the input of the digital to analogue convertor. The predistorter 108 thus predistorts the multicarrier output of the combiner 110 and outputs a predistorted multicarrier signal. The feedback path is the same in the first and second embodiments and accordingly the predistorter 108 operates in a similar manner to that shown in the first embodiment. However, phase correction is not applied and the amplitude correction is the</p>

Claim No.	'204 Patent	Exemplary Evidence of Anticipation and/or Obviousness
		<p>same for all frequencies. This solution is simple but may not provide the required performance in all cases.” 7:39-52.</p> <p>“Reference will now be made to FIG. 8 which shows a second predistorter 108 b which can be used in the second embodiment shown in FIG. 5. This second predistorter 108 comprises n subtractors 208 each of which receives an output from a respective one of the digital modulators. Each subtracter 208 also receives a corresponding input from the channelizer 140 as in the first embodiment. Each subtracter 208 thus receives two modulated signals. The two signals received by each subtracter 208 are subtracted one from the other to generate a difference signal. This output difference signal is input to the adaption algorithm block 204 which is the same as discussed in relation to the first predistorter of FIG. 7. As with the first predistorter of FIG. 7, the adaption algorithm block 204 also receives an input from the microcontroller 142 with information concerning the frequency. The adaption algorithm block 204 provides amplitude coefficients on its output which are output to the look-up table 200. Unlike the embodiment shown in FIG. 7, the look-up table receives the multicarrier signal from the combiner 110 which defines an address in the look-up table. Accordingly, the multicarrier signal is modified in accordance with the amplitude values from the look-up table and output to the digital to analogue convertor 112.” 7:53-8:8.</p> <p>“Reference is now made to FIG. 10 which shows a possible construction of the channeliser 140. The channeliser comprises n blocks 220, with one block provided for each frequency. Each block of the channeliser 220 comprises an input for receiving the output of the analogue to digital converter 138 and a frequency control signal from the microcontroller 142. The output from the analogue to digital converter 138 is input to first and second multipliers 222 and 224. The first multiplier 222 produces the I or in-band, component of the input signal whilst the second multiplier 224 produces the Q, or quadrature-phase component of the input signal. Each of the multipliers 222 and 224 receives a frequency from the numerically controlled oscillator 226. The frequency of the oscillator 226 is controlled by the frequency control input. The output of the oscillator 226 is connected directly to one of the multipliers 222 whilst the output for the second multipliers 224 is connected to a phase shifter 228 which shifts the phase of the output signal from the oscillator 226 by 90°. The phase shifted output signal of the oscillator 226 is input to the second multipliers 224.” 8:9-28.</p>

Claim No.	'204 Patent	Exemplary Evidence of Anticipation and/or Obviousness
		<p>“The output of each of the first and second multipliers 222 and 224 are connected to filters 230 and 232 which are arranged to filter out signal components introduced by the respective multipliers as well as other carriers within the multicarrier signal.” 8:29-33.</p> <p>“The frequency information provided by the microcontroller 142 is used by the predistorter 108 in the third embodiment to reconstruct the composite signal using any appropriate method. The methods require frequency information. One example is the inverse fast fourier transform technique which creates a spectral representation of the signal sampled in the time domain.” 8:37-43.</p> <p>“In the embodiments where the composite signal is predistorted, the combiner output consists of amplitude words, the correction occurring by adjusting the magnitude of the words. Nonlinearities in the amplifier output could be compensated by correcting the magnitude of the combiner output words with an inverse function. The correction may thus be dependent on the particular combiner output. This might occur by indexing a look-up table with the combiner output word and outputting the respective contents to the digital to analogue converter.” 9:18-27.</p>

Claim No.	'204 Patent	Exemplary Evidence of Anticipation and/or Obviousness
		<p style="text-align: center;">Fig.4.</p> <p style="text-align: center;">Fig. 4.</p>

Claim No.	'204 Patent	Exemplary Evidence of Anticipation and/or Obviousness
		<p style="text-align: center;">Fig.5.</p> <p style="text-align: center;">Fig. 5.</p>

Claim No.	'204 Patent	Exemplary Evidence of Anticipation and/or Obviousness
-----------	-------------	---

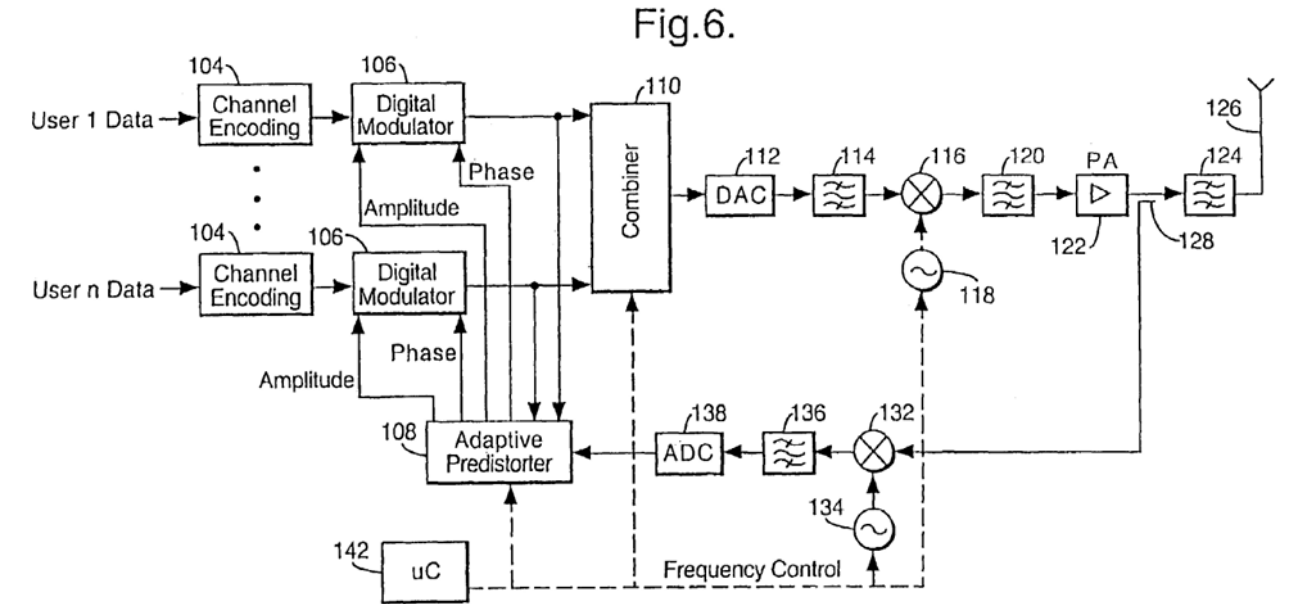
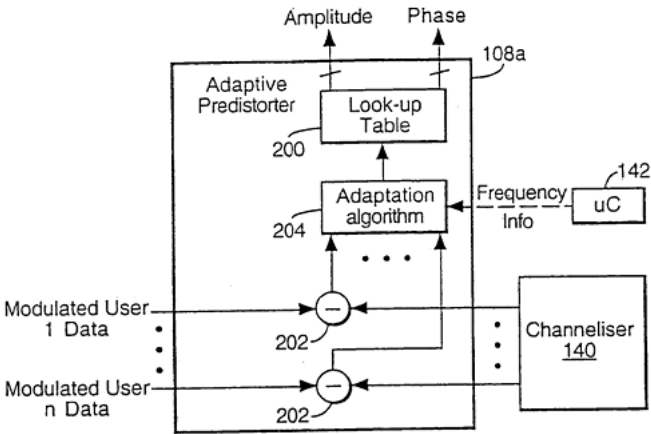
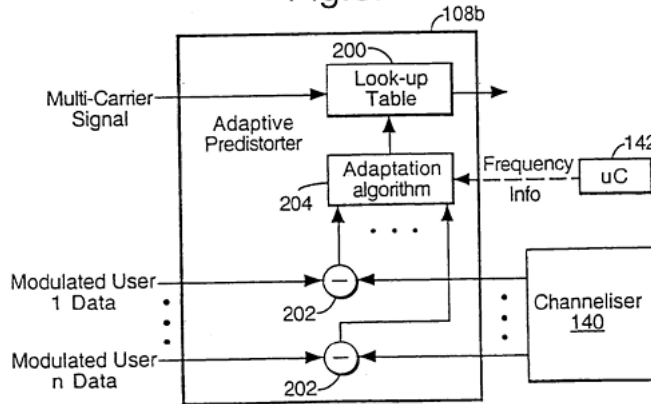
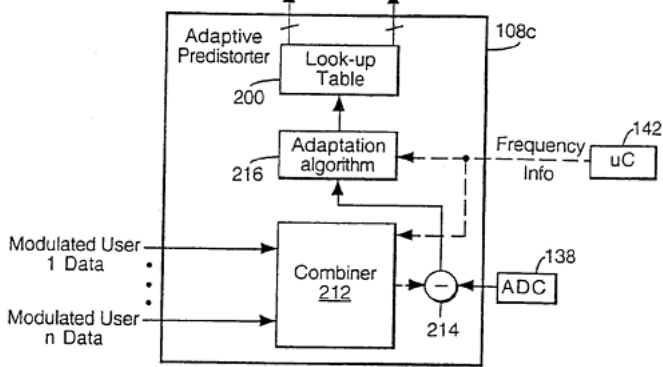
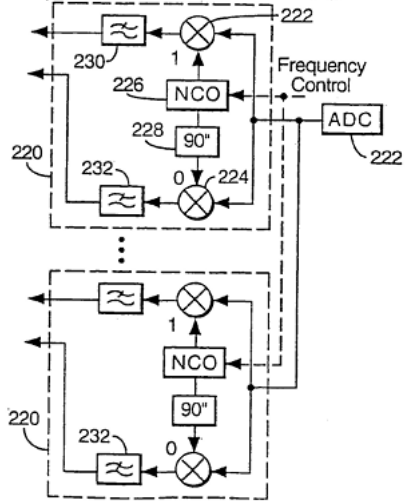

Fig. 6.

Claim No.	'204 Patent	Exemplary Evidence of Anticipation and/or Obviousness
		<p data-bbox="1144 188 1245 225">Fig.7.</p>  <p data-bbox="1144 788 1245 825">Fig.8.</p>  <p data-bbox="837 1286 1010 1323">Figs. 7 and 8.</p>

Claim No.	'204 Patent	Exemplary Evidence of Anticipation and/or Obviousness
		<p data-bbox="996 183 1276 223">Fig.9. Amplitude Phase</p>  <p data-bbox="974 678 1086 718">Fig.10.</p> <p data-bbox="974 718 1332 742">Principle of an NCO-Based Channeliser</p>  <p data-bbox="840 1284 985 1324">Figs. 9-10.</p>

Claim No.	'204 Patent	Exemplary Evidence of Anticipation and/or Obviousness
11	<p>The transmitter of claim 1, wherein the subsampling frequency f_s is in a range $2f_u/n \leq f_s \leq 2h/(n-1)$ where $1 \leq n \leq f_u/B$, and where B is a bandwidth of the amplified concurrent multi-band signals, and f_L f_u, are respective lower and upper frequencies of the bandwidth, and n is an integer.</p>	<p>Posti discloses and/or renders obvious the transmitter of claim 1, wherein the subsampling frequency f_s is in a range $2f_u/n \leq f_s \leq 2h/(n-1)$ where $1 \leq n \leq f_u/B$, and where B is a bandwidth of the amplified concurrent multi-band signals, and f_L f_u, are respective lower and upper frequencies of the bandwidth, and n is an integer.</p> <p><i>See</i> claim 1, <i>supra</i>, which is incorporated by reference herein.</p> <p><i>See, e.g.,</i></p> <p>“A multi frequency carrier transmitter comprises input means for receiving a plurality of different digital signals to be transmitted. The different signals are to be transmitted on different carrier frequencies. Amplifier means receive a composite signal comprising the different signals at the respective carrier frequencies and amplify the composite signal. Predistortion means predistort the plurality of digital signals prior to amplification of the composite signal by the amplification means. The predistortion provided by the predistortion means is subsequently altered in dependence on the difference between the input signals and the output at the amplifier means.” Abstract.</p> <p>“The present invention relates to a transmitter and a method of transmitting and in particular, but not exclusively, for use in a telecommunications network.”</p> <p>“The output of each transmit path 14–14' is connected to the input of a combiner 22 which combines the signals from each path 14–14' to provide a multicarrier signal. The output of the combiner 22 is connected to an antenna 24 which transmits the multicarrier signal containing each of the N different channels to the terminals in the cell served by the base station.” 1:53-59.</p> <p>“According to one aspect of the present invention, there is provided a multi frequency carrier transmitter comprising input means for receiving a plurality of different digital signals to be transmitted, said different signals to be transmitted on different carrier frequencies; amplifier means for receiving a composite signal comprising said different signals at the respective carrier frequencies and amplifying said composite signal; and predistortion means for predistorting said plurality of digital signals prior to amplification of the composite signal by said amplification means, said predistortion provided by said predistortion means being subsequently altered in</p>

Claim No.	'204 Patent	Exemplary Evidence of Anticipation and/or Obviousness
		<p>dependence on the difference between said input signals and the output at said amplifier means.” 2:43-55.</p> <p>“Accordingly, embodiments of the present invention provide a multi carrier transmitter which is able to deal with the problems of nonlinearity by using predistortion. The predistortion can be implemented more simply than the feedback method discussed in the prior art.” 2:55-60.</p> <p>“The output of the second bandpass filter 120 is input to the power amplifier 122 which amplifies the received input. The output of the amplifier 122 is input to a third bandpass filter 124 which is arranged to filter out any signal components introduced by the amplifier 122 which fall outside the radio frequency band of the signals to be transmitted. The output of the third bandpass filter 124 is passed to an antenna 126 which transmits the signals to the terminals in the cell associated with the base station.” 5:41-49.</p> <p>“The input means are preferably arranged to separately receive each of the different signals. Combiner means are preferably provided between the input means and the amplifier means for combining said plurality of different signals to provide a composite signal. This may be the composite signal input to the amplifier means or may be a composite signal at a lower, intermediate frequency. In the latter case, that composite signal at a lower frequency would be upconverted to provide the composite signal input to the amplifier means.” 2:61-3:3.</p> <p>“A feedback path may be arranged between the amplifying means and the predistorting means. Preferably, the predistorting means is arranged to compare the output from the amplifying means from the feedback path with the signals received by the receiving means and to provide, if necessary, at least one new predistortion value to be applied to at least one subsequent signal received by the receiving means. In this way, the predistorting means can adapt to changes in the operating conditions of the amplifier means.” 3:14-21.</p> <p>“Preferably, means are provided in the feedback path for separating the output of the amplifying means into a plurality of different signals. The predistorting means is preferably arranged to compare each of the separated signals with the corresponding signals received from the input means and to determine if the at least one predistortion value needs to be altered.” 3:23-29.</p>

Claim No.	'204 Patent	Exemplary Evidence of Anticipation and/or Obviousness
		<p>“Alternatively, the predistorting means is arranged to compare the composite signal from the amplifying means with a plurality of different signals to provide, if necessary, the at least one new predistortion value.” 3:30-33.</p> <p>“The amplifier means is preferably a nonlinear amplifier. The predistortion means is preferably arranged to compensate for the nonlinearity of the phase and/or amplitude of the output of the amplifier.” 3:45-58.</p> <p>“A digital to analogue converter may be provided for converting the plurality of signals to analogue form before said signals are amplified by said amplifier means.</p> <p>The transmitter is preferably incorporated in a base station or alternatively in a mobile station.</p> <p>According to a second aspect of the present invention, there is provided a multi carrier frequency transmission method comprising the steps of receiving a plurality of different digital signals to be transmitted, said different signals to be transmitted on different carrier frequencies; combining said plurality of different signals to provide a composite signal comprising the different signals at the respective carrier frequencies; and amplifying said composite signal, wherein the method further comprises the steps of: predistorting the plurality of different digital signals prior to amplification of the composite signal by the amplification means; and altering the predistortion applied to subsequent signals in dependence on the difference between said different signals and the amplified signal.” 3:49-67.</p> <p>“Reference will now be made to FIG. 4 which shows a first embodiment of the present invention. In particular, the transmit part 102 of the base station 100 is shown. The base station 100 is in a cellular system of the type shown in FIG. 1.” 4:30-34.</p> <p>“The transmit part 102 of the base station 100 comprises N channel encoders 104 where N is the number of different frequencies on which the base station 100 will transmit signals. Each channel encoder 104 receives the data to be transmitted on the particular frequency associated with the given channel encoder 104. The data is placed in a suitable form for transmission. This may include digitising the data, encoding the data, interleaving the data and/or any other step required to be carried out. As mentioned hereinbefore, each channel is on a different frequency after the</p>

Claim No.	'204 Patent	Exemplary Evidence of Anticipation and/or Obviousness
		<p>modulator. The signals output by the channel encoders 104 are in digital form and are at a baseband frequency. Coding, interleaving etc is performed on the digital baseband signals.” 4:35-36.</p> <p>“The output of each channel encoder 104 is input to a respective digital modulator 106. Each digital modulator 106 also receives two outputs from the adaptive predistorter 108. The first output from the predistorter 108 provides one or more amplitude coefficients which are used to predistort the signal which is output by the digital modulator to compensate for the non linearity of an amplifier 122 with respect to amplitude. The second output from the predistorter 108 provides one or more phase coefficients which are used to predistort the signal which is output by the modulator 106 to compensate for phase distortion provided by the amplifier 122. The amplifier 122 will be described in more detail hereinafter.” 4:48-60.</p> <p>“The predistortion to compensate for the phase and amplitude distortion introduced by the amplifier 122 can take place at the same time. The predistortion can be performed during or more preferably after the modulation has been carried out by the modulator 106.” 5:6-10.</p> <p>“The output of the second bandpass filter 120 is input to the power amplifier 122 which amplifies the received input. The output of the amplifier 122 is input to a third bandpass filter 124 which is arranged to filter out any signal components introduced by the amplifier 122 which fall outside the radio frequency band of the signals to be transmitted. The output of the third bandpass filter 124 is passed to an antenna 126 which transmits the signals to the terminals in the cell associated with the base station.” 5:41-49.</p> <p>“The adaptive predistorter 108 does not, as in the first embodiment, have outputs connected to the digital modulators 106. The output of the combiner 110 is connected to the input of the predistorter 108. The output of the predistorter 108 is connected to the input of the digital to analogue convertor. The predistorter 108 thus predistorts the multicarrier output of the combiner 110 and outputs a predistorted multicarrier signal. The feedback path is the same in the first and second embodiments and accordingly the predistorter 108 operates in a similar manner to that shown in the first embodiment. However, phase correction is not applied and the amplitude correction is the</p>

Claim No.	'204 Patent	Exemplary Evidence of Anticipation and/or Obviousness
		<p>same for all frequencies. This solution is simple but may not provide the required performance in all cases.” 7:39-52.</p> <p>“Reference will now be made to FIG. 8 which shows a second predistorter 108 b which can be used in the second embodiment shown in FIG. 5. This second predistorter 108 comprises n subtractors 208 each of which receives an output from a respective one of the digital modulators. Each subtracter 208 also receives a corresponding input from the channelizer 140 as in the first embodiment. Each subtracter 208 thus receives two modulated signals. The two signals received by each subtracter 208 are subtracted one from the other to generate a difference signal. This output difference signal is input to the adaption algorithm block 204 which is the same as discussed in relation to the first predistorter of FIG. 7. As with the first predistorter of FIG. 7, the adaption algorithm block 204 also receives an input from the microcontroller 142 with information concerning the frequency. The adaption algorithm block 204 provides amplitude coefficients on its output which are output to the look-up table 200. Unlike the embodiment shown in FIG. 7, the look-up table receives the multicarrier signal from the combiner 110 which defines an address in the look-up table. Accordingly, the multicarrier signal is modified in accordance with the amplitude values from the look-up table and output to the digital to analogue convertor 112.” 7:53-8:8.</p> <p>“Reference is now made to FIG. 10 which shows a possible construction of the channeliser 140. The channeliser comprises n blocks 220, with one block provided for each frequency. Each block of the channeliser 220 comprises an input for receiving the output of the analogue to digital converter 138 and a frequency control signal from the microcontroller 142. The output from the analogue to digital converter 138 is input to first and second multipliers 222 and 224. The first multiplier 222 produces the I or in-band, component of the input signal whilst the second multiplier 224 produces the Q, or quadrature-phase component of the input signal. Each of the multipliers 222 and 224 receives a frequency from the numerically controlled oscillator 226. The frequency of the oscillator 226 is controlled by the frequency control input. The output of the oscillator 226 is connected directly to one of the multipliers 222 whilst the output for the second multipliers 224 is connected to a phase shifter 228 which shifts the phase of the output signal from the oscillator 226 by 90°. The phase shifted output signal of the oscillator 226 is input to the second multipliers 224.” 8:9-28.</p>

Claim No.	'204 Patent	Exemplary Evidence of Anticipation and/or Obviousness
		<p>“The output of each of the first and second multipliers 222 and 224 are connected to filters 230 and 232 which are arranged to filter out signal components introduced by the respective multipliers as well as other carriers within the multicarrier signal.” 8:29-33.</p> <p>“The frequency information provided by the microcontroller 142 is used by the predistorter 108 in the third embodiment to reconstruct the composite signal using any appropriate method. The methods require frequency information. One example is the inverse fast fourier transform technique which creates a spectral representation of the signal sampled in the time domain.” 8:37-43.</p> <p>“In the embodiments where the composite signal is predistorted, the combiner output consists of amplitude words, the correction occurring by adjusting the magnitude of the words. Nonlinearities in the amplifier output could be compensated by correcting the magnitude of the combiner output words with an inverse function. The correction may thus be dependent on the particular combiner output. This might occur by indexing a look-up table with the combiner output word and outputting the respective contents to the digital to analogue converter.” 9:18-27.</p>

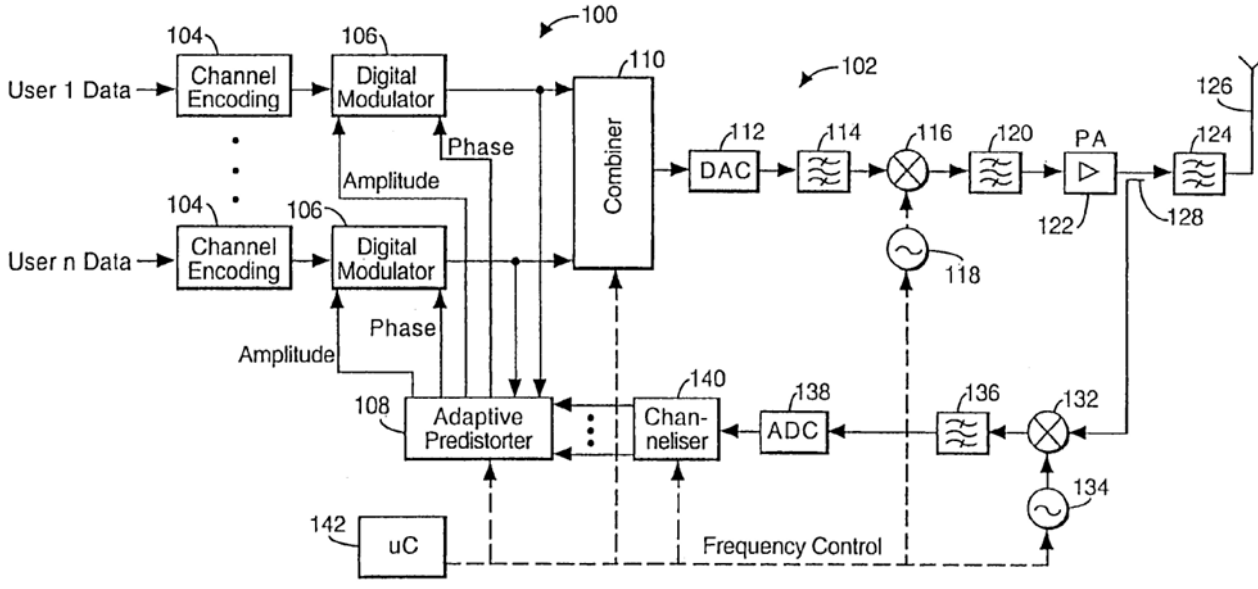
Claim No.	'204 Patent	Exemplary Evidence of Anticipation and/or Obviousness
		<p style="text-align: center;">Fig.4.</p>  <p style="text-align: center;">Fig. 4.</p>

Claim No.	'204 Patent	Exemplary Evidence of Anticipation and/or Obviousness
		<p style="text-align: center;">Fig.5.</p> <p style="text-align: center;">Fig. 5.</p>

Claim No.	'204 Patent	Exemplary Evidence of Anticipation and/or Obviousness
-----------	-------------	---

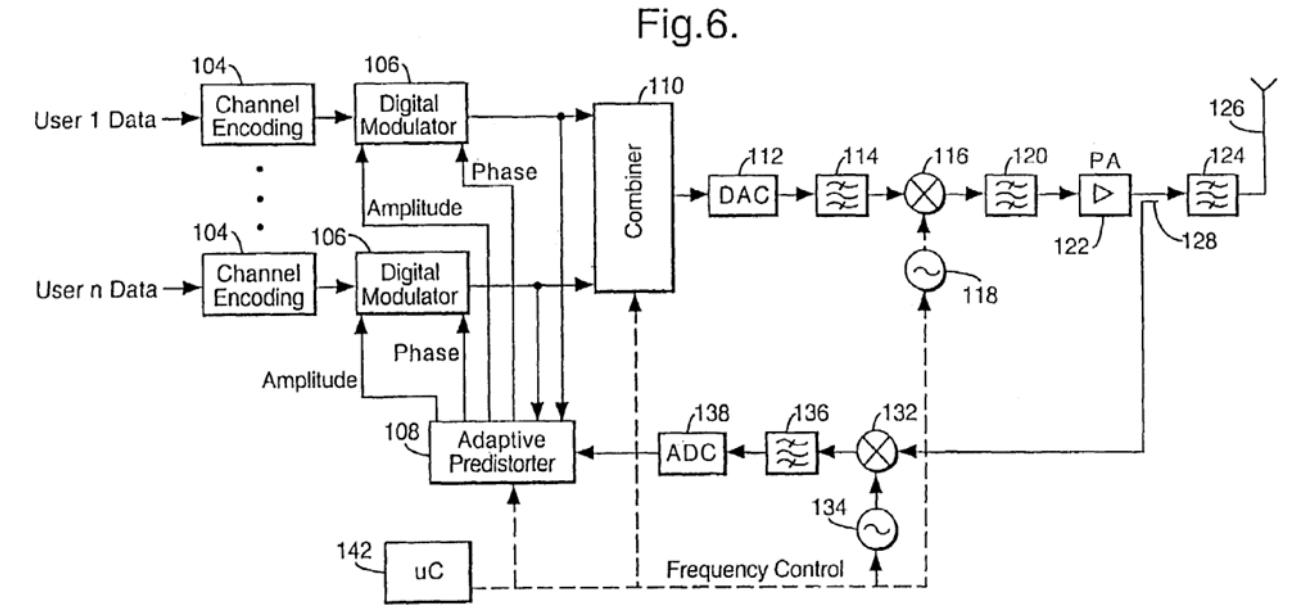
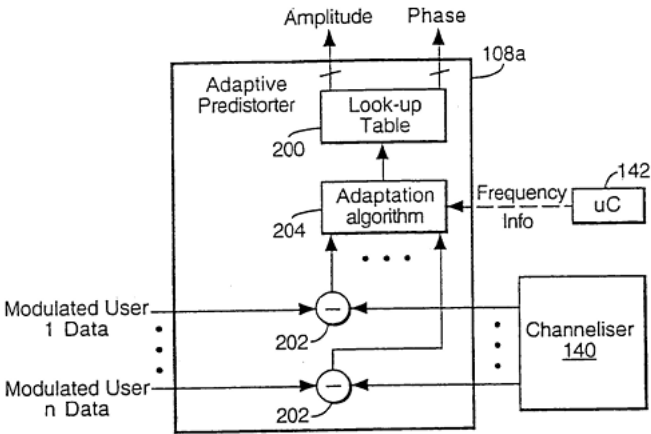
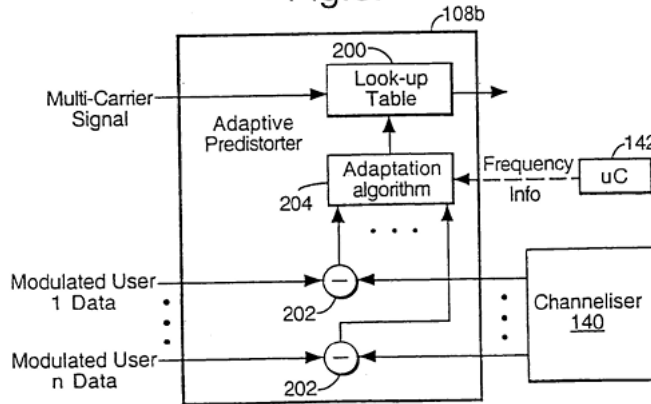
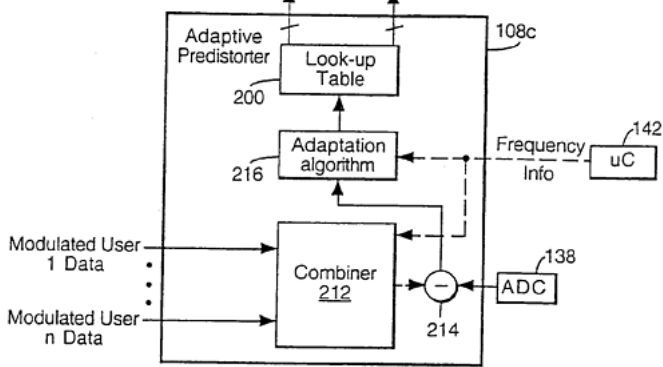
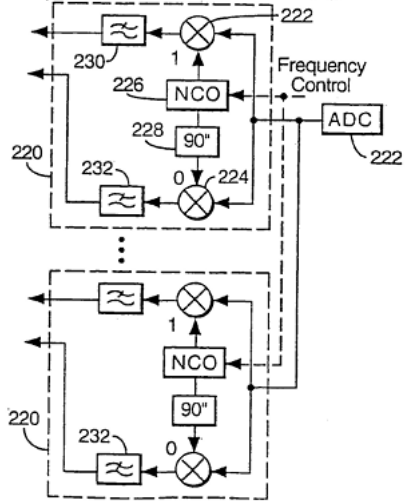

Fig. 6.

Claim No.	'204 Patent	Exemplary Evidence of Anticipation and/or Obviousness
		<p data-bbox="1144 188 1245 225">Fig.7.</p>  <p data-bbox="1144 788 1245 825">Fig.8.</p>  <p data-bbox="837 1286 1010 1323">Figs. 7 and 8.</p>

Claim No.	'204 Patent	Exemplary Evidence of Anticipation and/or Obviousness
		<p data-bbox="996 183 1276 223">Fig.9. Amplitude Phase</p>  <p data-bbox="974 678 1120 718">Fig.10.</p> <p data-bbox="974 718 1332 742">Principle of an NCO-Based Channeliser</p>  <p data-bbox="840 1284 985 1324">Figs. 9-10.</p>

Claim No.	'204 Patent	Exemplary Evidence of Anticipation and/or Obviousness
12[pre]	A method at transmitter comprising:	To the extent the preamble is limiting, Posti discloses and/or renders obvious a method at [sic] transmitter. <i>See, claim 1[pre], supra, which is incorporated by reference herein.</i>
12[a]	amplifying a modulated concurrent multi-hand signal to provide an amplified concurrent multi-band signal;	Posti discloses and/or renders obvious amplifying a modulated concurrent multi-hand signal to provide an amplified concurrent multi-band signal [sic]. <i>See, claim 1[a], supra, which is incorporated by reference herein.</i>
12[b]	predistorting the modulated concurrent multi-hand signal to compensate for a non-linearity of the power amplifier:	Posti discloses and/or renders obvious predistorting the modulated concurrent multi-hand signal to compensate for a non-linearity of the power amplifier. <i>See, claim 1[b], supra, which is incorporated by reference herein.</i>
12[c]	subsampling of the amplified concurrent multi-band signals at a subsampling frequency lower than twice a highest signal frequency in the amplified multi-band signal: and	Posti discloses and/or renders obvious subsampling of the amplified concurrent multi-band signals at a subsampling frequency lower than twice a highest signal frequency in the amplified multi-band signal. <i>See, claim 1[c], supra, which is incorporated by reference herein.</i>
12[d]	controlling the predistorting by the subsampled concurrent multi-band signal.	Posti discloses and/or renders obvious controlling the predistorting by the subsampled concurrent multi-band signal. <i>See, claim 1[c], supra, which is incorporated by reference herein.</i>

Claim No.	'204 Patent	Exemplary Evidence of Anticipation and/or Obviousness
13	The method of claim 12, wherein the subsampling frequency is greater than two times a signal bandwidth of the modulated concurrent multi-band signal.	Posti discloses and/or renders obvious the method of claim 12, wherein the subsampling frequency is greater than two times a signal bandwidth of the modulated concurrent multi-band signal. <i>See claims 10 and 12, supra, which is incorporated by reference herein.</i>
14	The method of claim 12, wherein the subsampling frequency is chosen to avoiding aliasing between replicas.	Posti discloses and/or renders obvious the method of claim 12, wherein the subsampling frequency is chosen to avoiding aliasing between replicas. <i>See claims 10 and 12, supra, which is incorporated by reference herein.</i>
15	The method of claim 14, wherein the chosen subsampling frequency f_s for a given signal bandwidth and carrier frequency f_c is in the range $2f_u/n \leq f_s \leq 2h/(n-1)$ where $1 \leq n \leq f_u/B $ and where B is a bandwidth of the amplified concurrent multi band signal, and f_L, f_u are respective lower and upper frequencies of the bandwidth, and n is an integer.	Posti discloses and/or renders obvious the method of claim 14, wherein the chosen subsampling frequency f_s for a given signal bandwidth and carrier frequency f_c is in the range $2f_u/n \leq f_s \leq 2h/(n-1)$ where $1 \leq n \leq f_u/B $ and where B is a bandwidth of the amplified concurrent multi band signal, and f_L, f_u are respective lower and upper frequencies of the bandwidth, and n is an integer. <i>See claims 11 and 14, supra, which is incorporated by reference herein.</i>