



Europäisches Patentamt
European Patent Office
Office européen des brevets



Publication number:

0 405 887 A1

12

EUROPEAN PATENT APPLICATION

21 Application number: **90306932.6**

51 Int. Cl.5: **D02G 3/28**

22 Date of filing: **25.06.90**

30 Priority: **26.06.89 US 371184**

72 Inventor: **Buchanan, Douglas Robert**
203 Main Street
Odessa, Ontario, K0H 2H0(CA)

43 Date of publication of application:
02.01.91 Bulletin 91/01

84 Designated Contracting States:
AT BE CH DE DK ES FR GB GR IT LI LU NL SE

74 Representative: **Harrison, David Christopher**
et al
MEWBURN ELLIS 2 Cursitor Street
London EC4A 1BQ(GB)

71 Applicant: **DU PONT CANADA INC.**
Box 2200 Streetsville Postal Station
Mississauga Ontario L5M 2H3(CA)

64 Composite yarn and method and apparatus for making composite yarn.

57 A composite yarn (42) comprising at least two yarn bundles plied together in alternating S and Z composite directions of twist separated by composite nodes of zero twist. At least one of the yarn bundles is a multi-strand bundle comprising at least two yarn strands (10). The strands of the bundles are twisted and the strands of the multi-strand bundle are plied together in alternating S and Z bundle directions of twist separated by bundle nodes of zero twist, so that the bundles all have substantially the same twist pattern. The composite nodes and the bundle nodes coincide and the composite direction of twist is opposite to said bundle direction of twist between nodes. A method of plying filaments to obtain the composite yarn and apparatus for doing so are also disclosed.

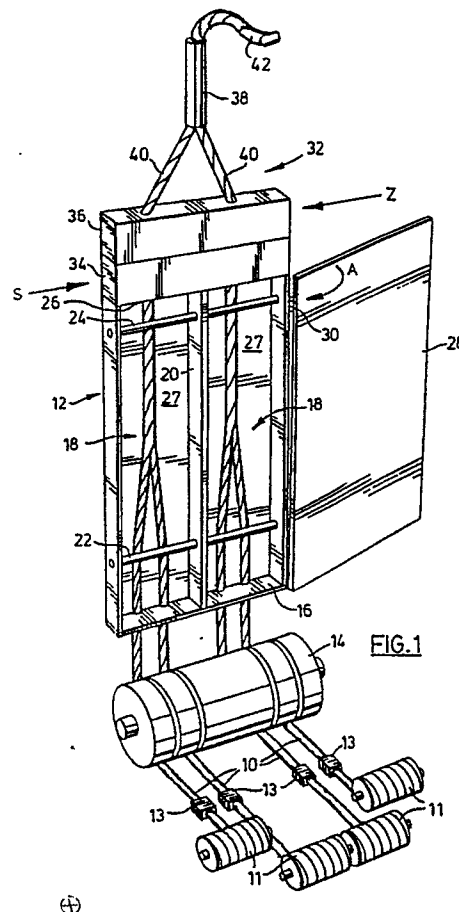

EP 0 405 887 A1

COMPOSITE YARN AND METHOD AND APPARATUS FOR MAKING COMPOSITE YARN

This invention relates to a composite yarn and a method and apparatus for making this yarn.

US-A-3,468,120 and 4,055,040 (E.I. du Pont) both disclose a method of producing alternate twist yarn wherein individual strands are kept separate and individually twisted in alternating S and Z directions and are then plied together by passing them through a compression tube. In this tube, the yarns partially untwist and wrap around each other in the opposite direction to the direction of twist of the individual filaments.

It is desired to provide a yarn having improved resiliancy and a unique appearance.

The present invention provides a composite yarn comprising at least two yarn bundles plied together in alternating S and Z composite directions of twist separated by composite nodes of zero twist. At least one of said yarn bundles is a multi-strand bundle comprising at least two yarn strands, said strands being plied together in alternating S and Z bundle directions of twist separated by bundle nodes of zero twist, so that the bundles all have substantially the same twist pattern. The composite nodes and the bundle nodes coincide and the composite direction of twist is opposite to said bundle direction of twist between nodes.

In another one of its aspects, the invention provides a method of plying yarns to obtain a composite yarn. The first step is to separate at least three spaced, parallel strands of yarn into at least two bundles at least one of which is a multi-strand bundle having at least two strands. Tension is applied to the strands and the strands of each multi-strand bundle are then converged while the bundles are kept separate from one another. Alternating twisting means are simultaneously applied to twist the strands of the bundles and ply the strands of each multi-strand bundle together in alternating S and Z bundle directions of twist separated by nodes, so that the bundles all have substantially the same twist pattern. The bundles are then converged in a restricted area to cause said bundles to partially untwist and they ply together in a composite direction of twist opposite to said bundle direction of twist to produce said composite yarn.

In a still further one of its aspects, the invention provides an apparatus for making a composite yarn. The apparatus comprises guide means for guiding at least three spaced parallel strands and separation means for separating said strands into at least two bundles, at least one of which is a multi-strand bundle having at least two strands. Tensioning means for applying equal tension to the

yarns is provided. Twisting means for twisting the strands in alternating S and Z bundle direction of twist between filament nodes of zero twist are also provided so that the bundles all have substantially the same twist pattern. First converging means for converging the strands of each multi-strand bundle is located between the guide means and the twisting means. Second converging means is located after the twisting means for converging the bundles in a restricted area and allowing the bundles to partially untwist and ply together in a composite direction of twist, which is opposite to the bundle direction of twist.

This novel method and apparatus for twisting yarn provides yarn with two levels of twist. The individual bundles all have substantially the same twist pattern and the bundles are plied together in a twist pattern that is opposite to the pattern of the individual bundles. The composite yarn is therefore generally stronger than the individual yarns used to make it and so is ideal for use as sewing thread or weaving yarn in high strength applications. This yarn may also be used to make carpet which is more resilient than and has a different appearance than conventional carpet made from the same type of fibre.

DESCRIPTION OF THE PREFERRED EMBODIMENTS

Practically any type of fibre may be used in accordance with the present invention, for example nylon, spandex, polyester, polyolefin, carbon fibre, hemp, jute and cotton. The filaments used to make the yarn may be made of different materials from one another and may be of different deniers and densities. Also, the number of filaments in each composite yarn bundle do not need to be the same. For example, in a composite yarn made up of two bundles, one bundle may have only one strand and the other bundle may have two or more strands.

The invention will be further described with respect to the following drawings in which Figure 1 is a diagrammatic representation of an apparatus for making a composite yarn.

Figure 1 shows four spaced, parallel strands of yarn being unwound from packages 11. An equal amount of tension is applied to each strand 10 by tensioning devices 13 before the strands 10 enter an apparatus 12 for making composite yarn. The apparatus comprises a separation roll 14 for guiding and separating the individual filaments,

above which is located an alignment guide 16. The guide 16 leads to a pair of passages 18 separated by a separation plate 20. A first retaining pin 22 is located adjacent to the guide 16 in the passage and a second retaining pin 24 is located above the first pin 22 adjacent to the end 26 of the passages 18. Small gaps (not shown) are located between the pins 22, 24 and a rear plate 27 of the passages so that the strands 10 are squeezed between the pins and the plate 27 when they pass through the gaps. A cover plate 28 is mounted on hinges 30 adjacent to the passage and is rotatable in the direction indicated by arrow A to cover the passages 18.

A twisting apparatus 32 is located above the second retaining pin 24. This apparatus 32 comprises a lower air jet 34 for applying twist to the yarn in the S direction and an upper air jet 36 for applying twist to the yarn in the Z direction. These jets 34, 36 are alternately actuated for equal periods of time. A compression tube 38 is located above the twisting apparatus 32.

In operation, yarn strands 10 are unwound from each of the packages 11 and an equal amount of tension is applied to each of the strands by the tension devices 13. The strands are then guided into the apparatus 12 by the separation roll 14, which also helps to separate the strands from one another. The strands then pass through the alignment guide 16 which guides the strands into one or the other of the passages. The strands then pass through the gap between the first retaining pin 22 and the plate 27 and then through the gap between the second retaining pin 24 and the plate 27 and are thereby converged.

In the passages, the strands are twisted and plied together by the false twisting apparatus 32 in alternating S and Z bundle directions of twist, with equally spaced nodes of zero twist in between. The distance between nodes in the bundles is a function of the frequency with which the air jets are switched on and off and of the yarn forwarding speed. The level of twist is determined by the level of tension in the strands and the air pressure of the twisting means. By the time the converged strands pass the twisting apparatus 32, a pair of twisted bundles 40 of strands is created. The resultant bundles have substantially the same twist pattern since they are acted upon by the same apparatus 32. The bundles then pass the twisting apparatus 32 and are converged by the compression tube 38. The bundles relax and tend to unravel in the tube 38, but are constrained from completely unravelling by the walls of the tube 38. Instead the bundles 40 only partially untwist and since they are in close proximity to one another, ply together in a direction of twist hereinafter called the composite direction of twist, which is opposite to the bundle direction of

twist. The bundles therefore are twisted together in a twist pattern that is opposite to that of the strands of the individual bundles.

The composite yarn 42 leaving the compression tube 38 therefore has two levels of twist. Since the direction of twist of the composite is always opposite to that of the individual bundles, the nodes of the bundles and composite coincide.

Although only a composite yarn comprising two bundles comprising two strands each is shown, many other combinations of bundles and strands are possible. For example, a two bundle composite yarn comprising a single strand bundle and a three strand bundle may be used or a three bundle yarn comprising a pair of two strand bundles and a three strand bundle may be used.

Claims

1. A method of plying yarns to obtain a composite yarn (42) comprising the steps of:
 - separating at least three spaced, parallel strands (10) of yarn into at least two bundles (40), at least one of which is a multi-strand bundle having at least two strands;
 - applying tension to the strands and converging the strands of the multi-strand bundle while keeping the bundles separate from one another;
 - simultaneously applying alternating twisting means (34,36) to the strands to twist them and ply together the strands of each multi-strand yarn in alternating S and Z bundle directions of twist separated by nodes, so that the bundles all have substantially the same twist pattern;
 - converging the bundles (40) in a restricted area (38) to cause them to partially untwist and thereby ply together in a composite direction of twist opposite between the nodes to said bundle direction of twist, to produce said composite yarn (42).
2. An apparatus for making a composite yarn comprising:
 - tensioning means (13) for applying equal tension to at least three spaced parallel strands (10);
 - separation means (14,16) for separating the strands into at least two bundles, at least one of which is a multi-strand bundle having at least two strands;
 - twisting means (32) for twisting the strands in alternating S and Z bundle direction of twist between filament nodes of zero twist so that the bundles all have substantially the same twist pattern;
 - first converging means (22,24,27) for converging the strands of each multi-strand bundle located between said tensioning means (13) and twisting means (34);
 - a compression tube (38) located after said twisting means (32) for converging said bundles in a restricted area and allowing said bundles to partially

untwist and ply together in a composite direction of twist, which is opposite to the bundle direction of twist.

3. The apparatus of claim 2 wherein the first converging means comprises a pair of spaced retaining pins (22,24). 5

4. The apparatus of claim 2 or claim 3 wherein the guide means comprises a plurality of spaced, longitudinally extending passages (18), wherein each bundle of strands passes through a separate one of said passages. 10

15

20

25

30

35

40

45

50

55

4

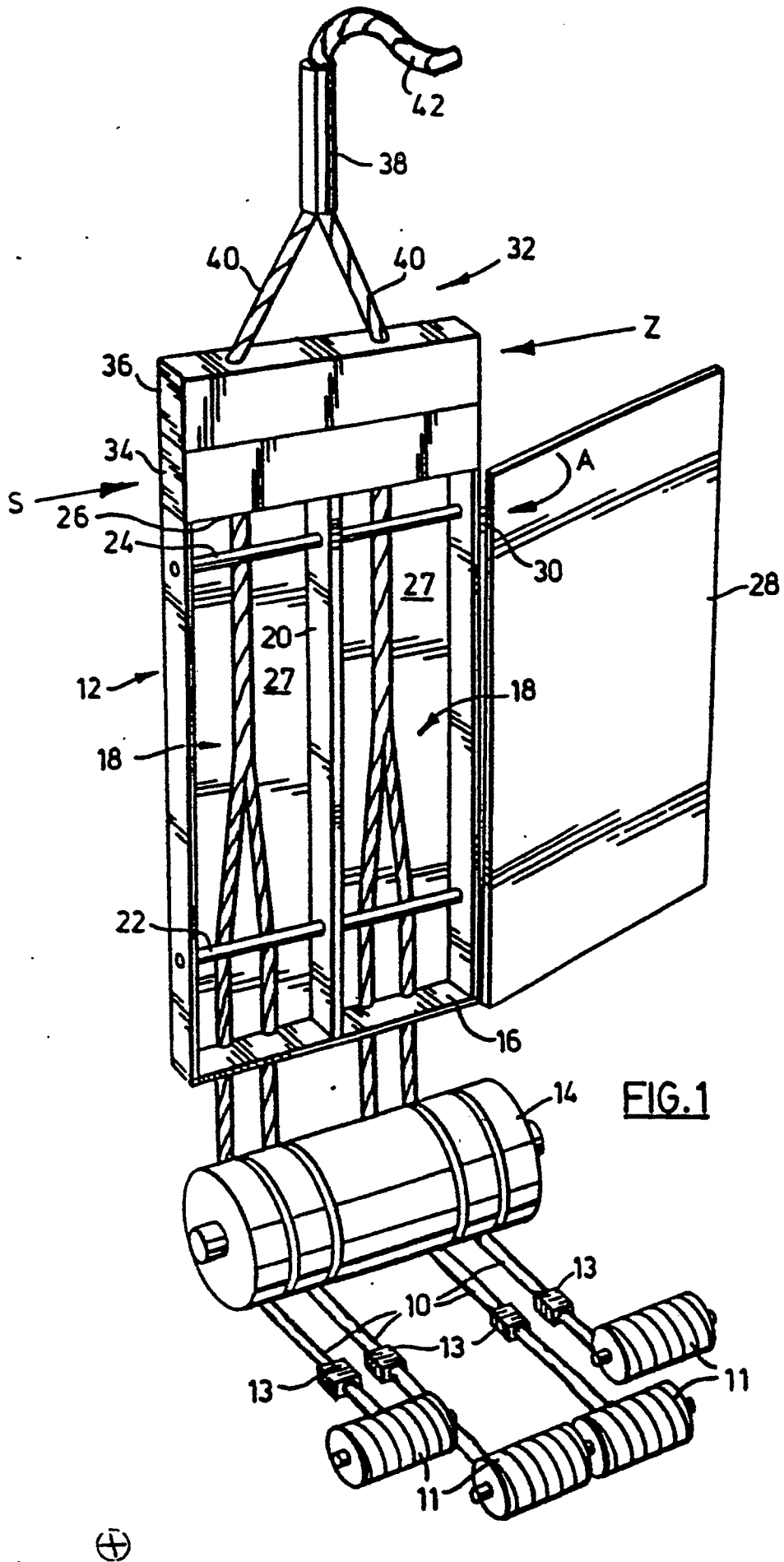

FIG. 1



DOCUMENTS CONSIDERED TO BE RELEVANT			
Category	Citation of document with indication, where appropriate, of relevant passages	Relevant to claim	CLASSIFICATION OF THE APPLICATION (Int. Cl.5)
X	GB-A-1047503 (E.I. DU PONT DE NEMOURS COMP.) * page 5, lines 12 - 77; figure 6 *	1	D02G3/28
A	---	2	
X	GB-A-2023674 (WWG IND. INC.) * page 3, line 100 - page 4, line 7; figures 1-4 *	1	
A	-----	2	
The present search report has been drawn up for all claims			TECHNICAL FIELDS SEARCHED (Int. Cl.5)
			D02G
Place of search		Date of completion of the search	Examiner
THE HAGUE		14 SEPTEMBER 1990	HOEFER W. D.
CATEGORY OF CITED DOCUMENTS			
X : particularly relevant if taken alone		I : theory or principle underlying the invention	
Y : particularly relevant if combined with another document of the same category		E : earlier patent document, but published on, or after the filing date	
A : technological background		D : document cited in the application	
O : non-written disclosure		L : document cited for other reasons	
P : intermediate document		
		& : member of the same patent family, corresponding document	

1

EPO FORM 1503 03.92 (P.0401)