

UNITED STATES PATENT AND TRADEMARK OFFICE  
BEFORE THE PATENT TRIAL AND APPEAL BOARD

---

**SAMSUNG ELECTRONICS CO., LTD., and  
SAMSUNG ELECTRONICS AMERICA, INC.,**

Petitioners,

v.

**ICASHE, INC.,**

Patent Owner.

---

Case IPR2025-00639  
Patent No. 9,122,965

---

**PETITION FOR *INTER PARTES* REVIEW**

**TABLE OF CONTENTS**

I.	INTRODUCTION .....	1
II.	MANDATORY NOTICES UNDER 37 C.F.R. §42.8.....	5
	A. Real Party-in-Interest .....	5
	B. Related Matters.....	5
	C. Lead and Back-Up Counsel.....	6
III.	PAYMENT OF FEES .....	6
IV.	REQUIREMENTS FOR <i>INTER PARTES</i> REVIEW.....	7
	A. Grounds for Standing .....	7
	B. Identification of Challenge.....	7
	1. The Specific Art on Which the Challenge Is Based .....	7
	2. Statutory Grounds on Which the Challenge Is Based .....	8
V.	'965 PATENT AND PROSECUTION HISTORY.....	8
	A. '965.....	8
	B. Prosecution History .....	12
	1. '965 Prosecution .....	12
	2. '722 Prosecution .....	13
	C. Priority Date of the Claims.....	15
VI.	§325(d) AND §314(a) DISCRETION DOES NOT APPLY .....	16
	A. §325(d) .....	16
	B. §314(a).....	18
VII.	LEVEL OF ORDINARY SKILL IN THE ART.....	23
VIII.	CLAIM CONSTRUCTION .....	23
IX.	GROUND OF UNPATENTABILITY.....	23
	A. Ground 1: Bangs (Claims 1-20) .....	24
	1. Overview of Bangs.....	24
	2. Claim Chart .....	29
	B. Ground 2: Bangs in View of Kerdraon (Claims 1–20).....	69

C. Ground 3: Bangs in View of Koh (Claims 1–20) .....74  
X. SECONDARY CONSIDERATIONS .....77  
XI. CONCLUSION.....78

**EXHIBIT LIST**

Exhibit No.	DESCRIPTION
1001*	U.S. Patent No. 9,122,965 (“965”)
1002*	File History of U.S. Application No. 14/517,495 (“965FH”)
1003*	Declaration of Emmanouil Tentzeris in Support of Petition for <i>Inter Partes</i> Review of U.S. Patent. No. 9,122,965 (“Tentzeris Decl.”)
1004	U.S. Patent App. Pub. No. 2010/0112941 (“Bangs”)
1005	U.S. Patent App. Pub. No. 2009/0040022 (“Finkenzeller”)
1006	U.S. Patent App. Pub. No. 2009/0215489 (“Kerdraon”)
1007	U.S. Patent App. Pub. No. 2008/0073426 (“Koh”)
1008	<i>Reserved</i>
1009	File History for U.S. Patent Application No. 12/188,346 (“346 Application File History”)
1010	<i>Reserved</i>
1011	File History for U.S. Patent No. 9,483,722 (“722 File History”)
1012 - 1014	<i>Reserved</i>
1015	Dachs, C., NFC — The Intuitive Contactless Technology Becomes Reality, 122 E&I Elektrotechnik und Informationstechnik 466 (Dec. 1, 2005) (“Dachs”)
1016	U.S. Patent No. 9,483,722 (“722”)
1017	U.S. Patent App. Pub. No. 2005/0224589 (“Park”)
1018	U.S. Patent No. 8,260,199 (“Kowalski”)
1019	U.S. Patent No. 6,282,407 (“Vega”)
1020	U.S. Patent App. Pub. No. 2008/0186166 (“Zhou”)

Exhibit No.	DESCRIPTION
1021	U.S. Patent App. Pub. No. 2007/0035396 (“Chand”)
1022	U.S. Patent App. Pub. No. 2008/0163361 (“Davis”)
1023	U.S. Patent No. 5,943,624 (“Fox”)
1024 - 1025	<i>Reserved</i>
1026	U.S. Patent App. Pub. No. 2008/0235796 (“Buhr”)
1027 - 1030	<i>Reserved</i>
1031	U.S. Patent App. Pub. No. 2004/0133787 (“Doughty”)
1032 - 1035	<i>Reserved</i>
1036	Mayes, K. et al., Smart Cards, Tokens, Security and Applications (December 11, 2007)
1037-1049	<i>Reserved</i>
1050	Docket Control Order, <i>iCashe, Inc. v. Samsung Electronics Co.</i> , No. 2:24-cv-00429-JRG (E.D. Tex.)
1051	Docket Control Order, <i>Valtrus Innovations Ltd. v. NTT Data Services, LLC</i> , No. 2:24-cv-00361, (E.D. Tex.)
1052	Docket Control Order, <i>Fleet Connect Solutions LLC v. The Kroger Co.</i> , No. 2:24-cv-00430 (E.D. Tex.)
1053	Docket Control Order, <i>C47 Technologies LLC v. TCL Technology Group Corporation f/k/a TCL Corporation</i> , No. 2:24-cv-00417 (E.D. Tex.)
1054	Docket Control Order, <i>SiOnyx, LLC v. Samsung Electronics, Co., Ltd.</i> , No. 2:24-cv-00408 (E.D. Tex.)
1055	Docket Control Order, <i>Stingray IP Solutions LLC v. Allegion Public Limited Company</i> , No. 2:24-cv-00396 (E.D. Tex.)
1056	Docket Control Order, <i>ElectraLED, Inc. v. Astera LED Technology GmbH</i> , No. 2:24-cv-00512 (E.D. Tex.)
1057	Docket Control Order, <i>Alto Dynamics, LLC v. Fresha.com SV Ltd.</i> , 2:24-cv-00468 (E.D. Tex.)
1058	Docket Control Order, <i>Cloud Byte LLC v. Dell Inc.</i> , No. 2:24-cv-00637 (E.D. Tex.)

U.S. Patent No. 9,122,965  
Petition for *Inter Partes* Review

<b>Exhibit No.</b>	<b>DESCRIPTION</b>
1059	September 20, 2024 Production Letter in <i>iCashe, Inc. v. Samsung Electronics Co.</i> , No. 2:24-cv-00429-JRG (E.D. Tex.)
1060	December 12, 2024 Production Letter in <i>iCashe, Inc. v. Samsung Electronics Co.</i> , No. 2:24-cv-00429-JRG (E.D. Tex.)
1061*	Declaration of Cheryl Sloane in Support of Petition for <i>Inter Partes</i> Review of U.S. Patent No. 9,122,965
Petitioners have used the same exhibit number to refer to the same document across IPR2025-00639, -00640, and -00641, except for those exhibits designated by an *, which indicates that the exhibit is unique to each IPR proceeding.	

**TABLE OF ABBREVIATIONS**

<b>Abbreviation</b>	<b>DESCRIPTION</b>
'965	U.S. Patent No. 9,122,965 (“’965”) (Ex.1001)
'965FH	File History of U.S. Application No. 14/517,495 (Ex.1002)
'722FH	File History of U.S. Application No. 14/517,575 (Ex.1011)
Claims / Challenged Claims	Claims 1-20 of the '965
IPR	<i>Inter Partes</i> Review
Petitioners	Petitioners Samsung Electronics Co. Ltd. and Samsung Electronics America Inc.
PO	Patent Owner
POSITA	Person of Ordinary Skill in the Art
PTAB	Patent Trial and Appeal Board
USPTO	United States Patent and Trademark Office

## LIST OF CHALLENGED CLAIMS

**[1.pre]** A mobile device comprising:

**[1.a]** a smartcard controller;

**[1.b]** an antenna; and

**[1.c]** performance enhancement circuits coupled between the smartcard controller and the antenna, wherein the performance enhancement circuits include an amplifier and a load modulation circuit, and wherein the amplifier is coupled to amplify a signal received from the antenna and to provide an amplified signal to the smartcard controller.

**[2]** The mobile device of claim 1 wherein the antenna is tuned to operate at 13.56 MHz.

**[3]** The mobile device of claim 1 wherein the antenna comprises an inductive element too small to draw enough power sufficient to operate the smartcard controller from an interrogating radio frequency (RF) field.

**[4]** The mobile device of claim 1 wherein the smartcard controller is coupled to be powered by the mobile device.

**[5]** The mobile device of claim 1 wherein the performance enhancement circuits are coupled to be powered by the mobile device.

**[6]** The mobile device of claim 1 wherein the mobile device comprises a mobile phone.

**[7.pre]** A mobile device comprising:

**[7.a]** a smartcard controller;

**[7.b]** an antenna; and

**[7.c]** performance enhancement circuits coupled between the smartcard controller and the antenna, wherein the performance enhancement circuits include an amplifier and an active transmit driver circuit, and wherein the amplifier is coupled to amplify a signal received from the antenna and to provide an amplified signal to the smartcard controller.

**[8]** The mobile device of claim 7 wherein the antenna is tuned to operate at 13.56 MHz.

**[9]** The mobile device of claim 7 wherein the antenna comprises an inductive element too small to draw enough power sufficient to operate the smartcard controller from an interrogating radio frequency (RF) field.

**[10]** The mobile device of claim 7 wherein the smartcard controller is coupled to be powered by the mobile device.

**[11]** The mobile device of claim 7 wherein the performance enhancement circuits are coupled to be powered by the mobile device.

**[12]** The mobile device of claim 7 wherein the mobile device comprises a mobile phone.

**[13.pre]** A mobile device comprising:

**[13.a]** a smartcard controller;

**[13.b]** an antenna;

**[13.c]** an amplifier coupled to amplify signals received at the antenna and drive the smartcard controller; and

**[13.d]** a driver circuit to drive the antenna with data provided by the smartcard controller.

**[14]** The mobile device of claim 13 wherein the driver circuit comprises a load modulation circuit.

**[15]** The mobile device of claim 13 wherein the driver circuit comprises an active transmit driver circuit.

**[16]** The mobile device of claim 15 wherein the active transmit driver circuit is coupled to be powered by the mobile device.

**[17]** The mobile device of claim 13 wherein the amplifier is coupled to be powered by the mobile device.

**[18]** The mobile device of claim 13 wherein the antenna is tuned to operate at 13.56 MHz.

**[19]** The mobile device of claim 13 wherein the antenna comprises an inductive element too small to draw enough power sufficient to operate the smartcard controller from an interrogating radio frequency (RF) field.

**[20]** The mobile device of claim 13 wherein the mobile device comprises a mobile

phone.

Pursuant to §§311-319 and §42.1,<sup>1</sup> Samsung Electronics Co. Ltd. and Samsung Electronics America Inc. (“Petitioners”) respectfully petition for *inter partes* review of claims 1-20 (“Claims”) of U.S. Patent No. 9,122,965 (Ex.1001, “’965”). There is a reasonable likelihood—and it is highly likely—that at least one challenged claim is unpatentable as explained herein. Petitioners request review of the Claims and judgment finding them unpatentable under §§102 and 103.

## I. INTRODUCTION

The ’965 is directed to “contactless smartcard devices,” namely a mobile computing device that can be used in NFC smartcard applications. ’965, 1:5-9, 8:44-50. The mobile device includes a **smartcard controller**, **antenna**, **amplifier**, and a **load modulation circuit** (Fig. 15) or **active transmit driver circuit** (Fig. 21). ’965, 14:66-15:15, 16:32-46. Tentzeris ¶32.

---

<sup>1</sup> Section cites are to 35 U.S.C. or 37 C.F.R. as context indicates. All emphasis/annotations added unless noted. Figure annotations herein generally quote the Claims for reference. Citations herein are exemplary and not meant to be limiting.

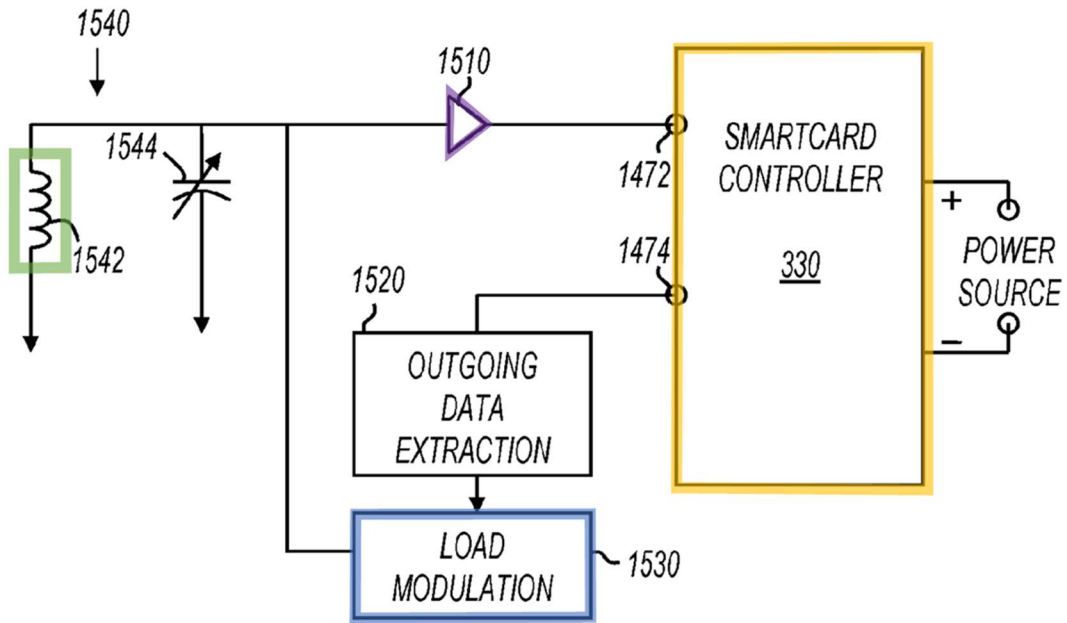

FIG. 15

'965, Fig. 15.

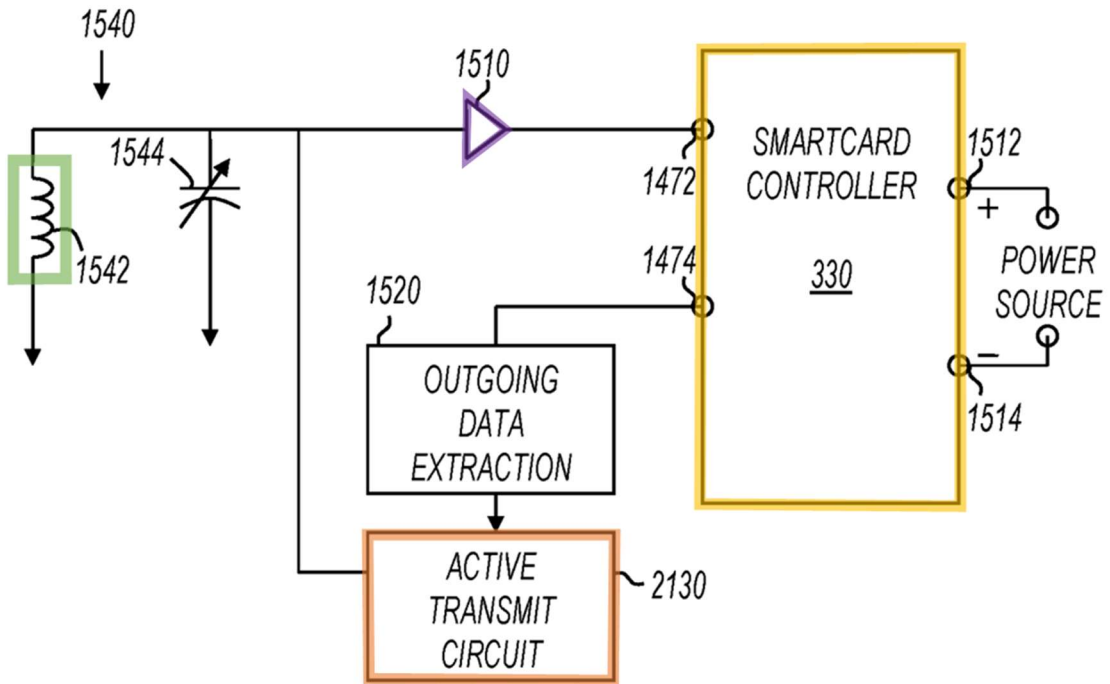

FIG. 21

'965, Fig. 21.

But the '965 admits that a **smartcard controller**, an **antenna**, a **load modulation circuit**, and an **active transmit driver circuit** were each known. '965, 1:11-20, 2:39-41, 1:50-2:3, 15:42-45 (admitting “smartcard controllers,” “tag antenna[s]...operat[ing] at 13.56 MHz,” “active...transmi[ssion],” and “Load modulation driver circuits” as prior art). Tentzeris ¶33.

During prosecution, the Examiner allowed the Challenged Claims only after the Applicant amended the claims to recite “an amplifier...coupled to amplify a signal received from the antenna and to provide an amplified signal to the smartcard controller” and argued that the prior art did not teach an amplifier “in a signal path between” the antenna and smartcard controller. *See infra* §V.B. Tentzeris ¶34.

But the concept of amplifying a received RF signal before providing it to a controller for further processing was known prior to the '965. **Bangs** discloses an NFC-enabled mobile device comprising an **amplifier** coupled to a **smartcard controller** and **load modulation** and **active transmit driver** circuits. Bangs, [0041], [0046], [0049]-[0050], [0057], [0070], Fig. 2. The **amplifier** is situated between an **antenna element** and **smartcard controller** to amplify a received RF signal that is demodulated and provided to the **smartcard controller**. Bangs, [0049], Figs. 2 (providing a functional diagram of NFC communicator 100a with components providing NFC functionality 120 coupled to an antenna circuit 102), Fig. 3 (providing a functional diagram of antenna circuit 102). Tentzeris ¶35.



Bangs, Fig. 3. Tentzeris ¶¶35-36.

Accordingly, Petitioners request that the Board institute trial and find the Claims unpatentable.

## **II. MANDATORY NOTICES UNDER 37 C.F.R. §42.8**

### **A. Real Party-in-Interest**

Petitioners Samsung Electronics Co. Ltd. and Samsung Electronics America, Inc. are the real parties-in-interest. No other party had access to or control over the present Petition, and no other party funded or participated in preparation of the present Petition.

### **B. Related Matters**

The '965 is the subject of the following co-pending civil action:

*iCashe, Inc. v. Samsung Elecs. Co.*, No. 2:24-cv-00429 (E.D. Tex.) filed June 6, 2024 (“Texas Case”).

Petitioners have also filed petitions for IPR of the related U.S. Patents 9,483,722 (IPR2025-00640) and 11,694,053 (IPR2025-00641).

**C. Lead and Back-Up Counsel**

<b>Lead Counsel</b>	<b>Backup Counsel</b>
<p>James L. Davis, Jr. Reg. No. 57,325 <b>ROPES &amp; GRAY LLP</b> 525 University Avenue, 8th Floor Palo Alto, CA 94301 Phone: +1-650-617-4000 Fax: +1-617-235-9492 <a href="mailto:james.l.davis@ropesgray.com">james.l.davis@ropesgray.com</a></p> <p>Samsung-iCashe-IPR- Ropes@ropesgray.com</p> <p><b>Mailing address for all PTAB correspondence:</b> ROPES &amp; GRAY LLP IPRM—Floor 43 Prudential Tower 800 Boylston Street Boston, Massachusetts 02199-3600</p>	<p>Alexander E. Middleton Reg. No. 75,285 <b>ROPES &amp; GRAY LLP</b> 1211 Avenue of the Americas New York, NY 10036 Phone: 212-596-9000 Fax: 617-235-9492 <a href="mailto:alexander.middleton@ropesgray.com">alexander.middleton@ropesgray.com</a></p> <p>Frances Zhang Reg. No. 73,589 <b>ROPES &amp; GRAY LLP</b> 2099 Pennsylvania Avenue NW Washington, DC 20006 Phone: +202-508-4600 Fax: +1-617-235-9492 <a href="mailto:frances.zhang@ropesgray.com">frances.zhang@ropesgray.com</a></p>

Petitioners consent to electronic service of documents to the email addresses identified above.

**III. PAYMENT OF FEES**

The undersigned authorizes the Office to charge the fee required by §42.15(a) and any additional fees that might be due to Deposit Account No. 18-1945, under Order No. 110797-0057-652.

#### IV. REQUIREMENTS FOR *INTER PARTES* REVIEW

##### A. Grounds for Standing

Pursuant to §42.104(a), Petitioners certify the '965 is available for IPR. Petitioners and any real parties-in-interest are not barred or estopped from requesting IPR challenging the Claims on the grounds identified herein.

##### B. Identification of Challenge

Pursuant to §42.104(b) and (b)(1), Petitioners request IPR of the Claims and that the Board cancel the same as unpatentable.

##### 1. The Specific Art on Which the Challenge Is Based

Petitioners rely upon the following art (Tentzeris ¶¶61-62):

Name	Ex.	Publication	Filed	Published/ Issued	Prior art under at least
<b>Bangs</b>	1004	U.S. 2010/0112941	3/20/2008	5/6/2010	§§102(a)/(e)
<b>Kerdraon</b>	1006	U.S. 2009/0215489	2/26/2009	8/27/2009	§§102(a)/(b)/(e)
<b>Koh</b>	1007	U.S. 2008/0073426	9/24/2006	3/27/2008	§§102(a)/(b)/(e)

Each of the above references is prior art to the Claims based on the 3/1/2011 filing date of U.S. App. No. 13/038,341 (“’341-App.”) listed in the '965's priority claim.<sup>2</sup> Moreover, even if the Claims were entitled to the benefit of the earlier filed

---

<sup>2</sup> As discussed *infra* §V.C, the Claims are not entitled to the benefit of the earlier filed '346-App. filing date.

U.S. Pat. App. No. 12/188,346 (filed 8/8/2008) (“’346-App.,” filed 8/8/2008), **Bangs** and **Koh**, on which Grounds 1 and 3 are based, are still prior art. Tentzeris ¶¶63-64.

## 2. Statutory Grounds on Which the Challenge Is Based

Ground	Claim(s)	Basis	References
1	1-20	§102/103	Bangs
2		§103	Bangs in view of Kerdraon
3		§103	Bangs in view of Koh

## V. ’965 PATENT AND PROSECUTION HISTORY

### A. ’965

The purported “invention” of the ’965 relates to “contactless smartcard devices” implemented in a mobile device comprising “a **smartcard controller** and an **inductive element** capable of interacting with an NFC reader” according to “the ISO 14443 standard for contactless NFC devices.” ’965, 1:5-9, 5:11-20, 8:44-61. The ’965 purports to solve the problem of implementing NFC communication “in smaller mobile devices” to “allow smartcard controller functions to be accessed” from a mobile device, such as a mobile phone. ’965, 2:4-6, 2:42-45, 4:41-48, 11:13-16. Tentzeris ¶37.

The mobile device comprises a “**smartcard controller 330**”, “**antenna 1542**,” “**amplifier 1510**,” and “**active transmit driver circuit 2130**.” ’965, 1:11-20, 14:66-15:15, 15:49-57, 16:32-46, Fig. 21. Alternative to active transmit driver

circuit 2130, the mobile device may comprise **load modulation circuit 1530** for transmission. '965, 14:66-15:15, Fig. 15. **Smartcard controller 330** processes a received “memory access command.” See '965, 7:43-60, 13:32-40. The '965 admits “suitable” prior art **smartcard controllers** include “[t]he ‘SmartMX’ family of controllers available from NXP Semiconductors N.V.” '965, 8:44-61. Tentzeris ¶38.

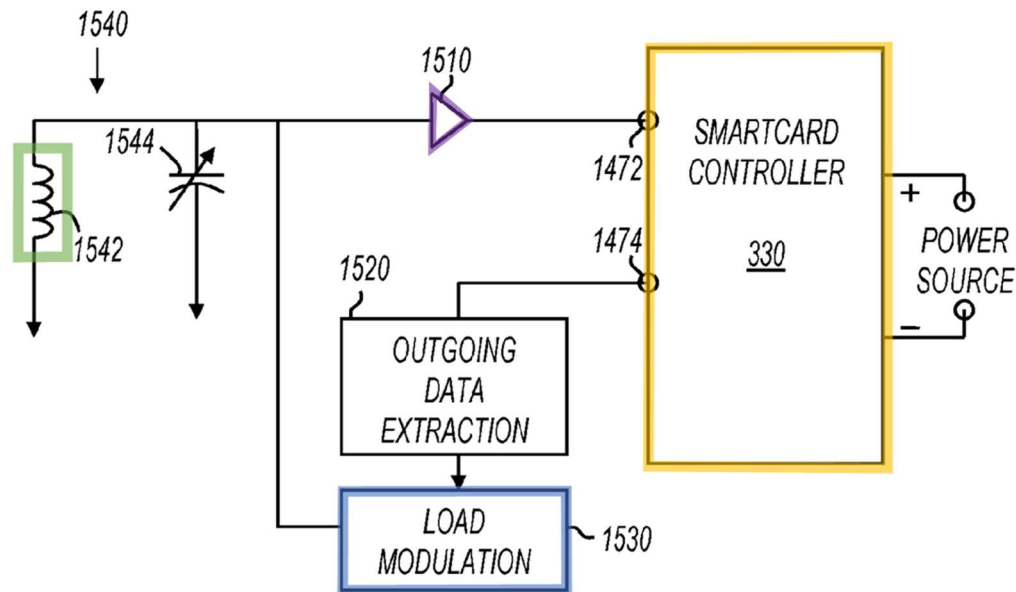

FIG. 15

'965, Fig. 15.

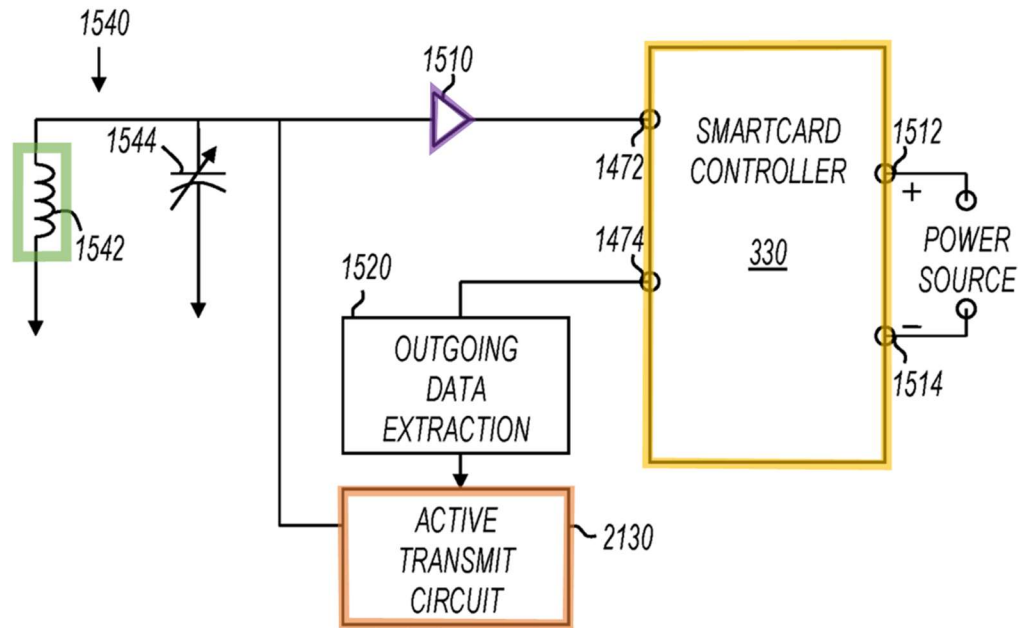

FIG. 21

'965, Fig. 21.

The mobile device further characterizes circuits coupled between **antenna 1542** and **smartcard controller 330** as “performance enhancement circuits.” '965, 14:66-15:57, 16:32-46, 17:4-13. The circuits (shown in Figures 15 and 21 above) comprise “**amplifier 1510**” in the receive circuit and a “driver circuit” in the transmit circuit. '965, 14:66-15:15, 16:32-46, 17:4-13. “**Antenna 1542** is a small inductive element” that forms a “tuned circuit” with capacitor 1544 “resonant at...13.56 MHz,” the frequency at which prior art “controllers provide RFID functionality.” '965, 8:44-61, 15:2-6. “**Amplifier 1510** amplifies the voltage received at **antenna 1542**” and provides “the amplified voltage...to the **smartcard controller.**” '965, 14:66-15:15. Tentzeris ¶39.

The transmit circuit may comprise “**active transmit driver circuit 2130**” or “**load modulation driver circuits 1530.**” ’965, 14:65-16:15, 16:32-46, Figs. 15, 21. **Active transmit driver circuit 2130** “actively transmit[s] a signal” and thus “increase[s]” the RFID card’s “usable distance when smartcard controller 330 is transmitting” data. ’965, 16:32-46. Specifically, **active transmit driver circuit 2130** includes circuits “to form a signal that mimics...[a modulated] interrogating RF field.” ’965, 16:32-46. **Load modulation driver circuit 1530** “load modulates” the **antenna circuit**, *i.e.*, “by modulating the impedance that the **antenna** presents” to the “interrogating field” from a nearby reader, to transmit data to the reader. ’965, 1:21-31, 15:40-48. The ’965 admits “Load modulation driver circuits are generally well known, and may be as simple as a switched transistor.” ’965, 15:40-48. Tentzeris ¶40.

The **smartcard controller 330** and the performance enhancement circuits comprising **amplifier 1510** and the **active transmit driver circuit 2130** are coupled to be powered by the host mobile device. ’965, 8:36-43, 16:44-46. The ’965 describes “a power delivery mechanism from the host” power source to the claimed components include “[c]ycling power” through an “interface” with the host mobile device. ’965, 8:36-43, 14:15-65. The ’965 admits that powering a tag device with a “local power source,” such as a battery, was known in the prior art. ’965, 1:11-21. Tentzeris ¶41.

**B. Prosecution History**

**1. '965 Prosecution**

The '965 issued from U.S. Pat. App. 14/517,495 (“'495-App.”), filed 10/17/2014. The '495-App. claims priority, through a chain of continuations and one continuation-in-part, to U.S. Pat. App. No. 12/188,346 (“'346-App.”) filed 8/8/2008. Tentzeris ¶¶42-43.

During prosecution, the '495-App. was subject to one Non-Final Rejection based on §102, §103, and nonstatutory double patenting grounds. *See* '965FH, 1512-19 (Office Action dated 11/19/2014). The Examiner found (i) all pending claims were covered by the Applicant’s copending U.S. App. No. 14/517,567 (“'567-App.”); (ii) all pending independent claims and most dependent claims were anticipated under §102 by Fox (U.S. 5,943,624); and (iii) three pending dependent claims were obvious under §103 over Fox in view of Rosenberg (U.S. 7,110,792). Tentzeris ¶44.

To overcome the several rejections, the Applicant filed a terminal disclaimer to the '567-App. and amended the pending independent claims to include the limitation “wherein the amplifier is coupled to amplify a signal received from the antenna and to provide an amplified signal to the smartcard controller.” '965FH, 1572-77 (Terminal Disclaimer filed 5/18/2015), 1589-97 (Amendment dated 5/18/2015). The Examiner thereafter issued a Notice of Allowance and the '965

issued on 9/1/2015. '965FH, 1605-09 (Notice of Allowance dated 7/21/2015), 1626 (Issue Notification). Tentzeris ¶45.

## 2. '722 Prosecution

The '965 claims contain claim language that overlaps with the claims of U.S. Patent No. 9,483,722 (“'722”), a related patent that shares the same specification as the '965. '722 (Ex.1016); Tentzeris ¶¶46-47.

First, regarding the “amplifier” limitation that was added to the pending claims of the '495-App to secure allowance of the '965 claims (*see* §V.B.1), the same language—“an amplifier coupled to amplify a signal received from the antenna and to provide an amplified signal to the smartcard controller”—was added during prosecution of the '722, but the claims were nevertheless rejected as obvious over new art. *See* '722FH, 1652-55. According to the Examiner, U.S. Patent Appl. Pub. 2005/0224589 (“Park”) “discloses a smart card with an amplifier to amplify the received signal to provide an amplified signal to the smartcard controller [0052]” and it “would have been obvious at the time of the invention to amplify the received signal so that the received data may be enhanced for better communication.” '722FH, 1695; Ex.1017, ¶52 (disclosing “demodulating the signal amplified by the amplifier 444 to generate the reader reception data and outputting the reader reception data to the controller 130”). Tentzeris ¶48.

Regarding the “smartcard controller” term, the Examiner relied on prior art

disclosure of controlling circuitry in integrated circuits (e.g., ISO 14443-compliant contactless IC card) to satisfy the “smartcard controller” limitations of the pending claims. ’722FH, 1579, 1696. For example, in the first office action, the Examiner relied on Kowalski’s (U.S. Patent No., Ex.1018) disclosure of “central processor 311” of a mobile phone to show a “smartcard controller.” ’722FH, 1579 (“Kowalski discloses a mobile phone comprising a smartcard controller (311).”); Ex.1018, 14:15, 14:50-58 (“central processor 311” of “mobile phone”), 1:25-35 (“NFC component” “integrated into a mobile phone 15” implements “contactless communication protocols” such as “ISO-14443-A, ISO 14443-B”). In the second office action, the Examiner additionally pointed to Park’s (U.S. Patent Appl. Pub. 2005/0224589, Ex.1017) disclosure of a “controller 130” within an “SD memory card having functions of a contactless integrated circuit (IC) card” to show “smartcard controller.” ’722FH, 1696 (“Park...discloses a smartcard with an amplifier to amplify the received signal to provide an amplified signal to the smartcard controller [0052]”); Ex.1017, ¶¶ 3, 17, 52, Fig. 1 (“controller 130” is within “SD memory card 100 having functions of a contactless integrated circuit (IC) card (ISO 14443 Types A and B)”). Applicant did not contest that the prior art “processor” or “controller” satisfied the claimed “smartcard controller,” instead amending the claims to overcome both prior art rejections. ’722FH, 1655, 1716 (amending claims “to overcome” prior art rejections without traversal). Tentzeris

¶49-51.

Additionally, with respect to the limitation “the antenna comprises an inductive element too small to draw enough power sufficient to operate the smartcard controller from an interrogating radio frequency (RF) field,” the Examiner relied on prior art disclosure of “inductive coupling of [two] antennas” to “maximize” “inductive coupling rate” to conclude that the antennas must be “small by themselves.” ’722FH, 1581 (citing Kowalski, 13:44-61); Ex.1018, 13:55-61 (“putting the antenna coils AC1, AC2 closer in order to bring the inductive coupling rate between the antenna coils to its maximum value”). Applicant did not contest this disclosure. ’722FH, 1655; Tentzeris ¶52.

### **C. Priority Date of the Claims**

The Claims are not entitled to the 2008 filing date of the ’346-App. because the ’346-App. fails to provide written description support for at least the following independent claim limitations: “performance enhancement circuits coupled between the smartcard controller and the antenna” (’965 claims 1, 7); “wherein the performance enhancement circuits include...a load modulation circuit” (’965 claim 1) or “an active transmit driver circuit” (’965 claim 7); an “amplifier...coupled to amplify a signal received from the antenna” (’965 claims 1, 7, 13) “to provide an amplified signal to the smartcard controller” (’965 claims 1, 7) and “drive the smartcard controller” (’965 claim 13); and “a driver circuit to drive the antenna with

data” (claim 13). The challenged independent claims and thus each of the Challenged Claims recites at least one of these limitations. Tentzeris ¶¶53-54.

The ’346-App does not disclose “performance enhancement circuits,” “amplifier,” “load modulation circuit,” “driver circuit,” nor “active transmit driver circuit.” ’965, 15:6-10, 16:32-46. *See generally* Ex.1009 (’346-App. File History), 40-78. While the ’346-App. generally discusses the inclusion of a smartcard controller in a host device, it does *not* describe the ’965 claimed “performance enhancement” circuits. *See generally* Ex.1009, 40-78. In its discussion of the background art, the ’346-App. makes cursory mention of prior art “Active tags” that have “a local power source” and “generally transmit information...using a locally generated RF carrier,” and of prior art “Passive tags” that use “energy...from an interrogating RF field” “to transmit response codes.” Ex.1009, 41. But there is no explanation of how this is done, let alone, a disclosure of a “load modulation circuit,” an “active transmit driver circuit,” or “driver circuit” (’965, cls. 1, 7, 13) for transmission as claimed in the ’965. *See generally* Ex.1009, 40-78. Moreover, there is no disclosure of the claimed connections or functionality of the claimed “load modulation circuit” or “active transmit driver circuit.” *Id.* Tentzeris ¶55.

## **VI. §325(d) AND §314(a) DISCRETION DOES NOT APPLY**

### **A. §325(d)**

There is no basis for discretionary denial under §325(d). The references relied

upon in the Grounds—**Bangs**, **Kerdraon**, and **Koh**—were not cited in an IDS or otherwise identified by the Examiner, or applied to reject claims during '965's prosecution. The Examiner also never considered the testimony of Petitioners' expert Dr. Tentzeris (Ex.1003) regarding the scope and content of these documents. Tentzeris ¶¶67-199.

Furthermore, the disclosures considered by the Examiner are not substantially the same as any of the references relied upon in the Grounds of the Petition. For example, **Bangs** (which is the primary reference in all Grounds in the Petition) teaches at least the limitation the Examiner believed was missing from the prior art: “amplifier is coupled to amplify a signal received from the antenna and to provide an amplified signal to the smartcard controller.” *See* V.B.1 ('965 Prosecution). For example, unlike the art cited during prosecution, **Bangs** discloses that an “amplifier 119” “amplif[ies]...a modulated RF signal” received from “antenna element 309,” and the amplified signal is provided to “demodulator 114...coupled to...controller 107.” *See* §IX ([1.d]); **Bangs**, [0049], [0059], Figs. 2-3; Tentzeris ¶¶67-176.

Even if the art or arguments were substantially the same, the Examiner erred in a manner material to the patentability of the Claims. Because the Examiner “did not expressly consider” nor issue any rejections based on the art relied on in this Petition, it is difficult, if not impossible, to explain “why the Examiner allowed the claims” or “how the Examiner might have considered the arguments presented in the

Petition.” *Bowtech, Inc. v. MCP IP, LLC*, IPR2019-00379, Pap. 14, \*20 (declining to exercise §325(d) discretion). Indeed, the Examiner did not recognize any art teaching that the claimed “amplifier is coupled to amplify a signal received from the antenna and to provide an amplified signal to the smartcard controller.” *See* V.B.1 (’965 Prosecution). To the extent art considered by the Examiner was substantially the same as the references identified in the Grounds, the Examiner erred by not rejecting the Claims for the reasons discussed in §IX. Tentzeris ¶¶67-196.

**B. §314(a)**

Co-pending district court litigation pending in the Eastern District of Texas also does not warrant the exercise of discretion under §314(a). *See Apple Inc. v. Fintiv, Inc.*, No. IPR2020-00019, Pap. 11 (designated precedential).

**Factor 1** weighs in favor of institution. Petitioners intend to seek a stay of the district court litigation pending the outcome of this IPR, along with other IPRs related to the litigation dispute. At the time of institution, it is highly unlikely that the Court will have conducted a *Markman* hearing, which is currently scheduled for October 28, 2025. Ex.1050, 3.

The Eastern District of Texas has routinely granted stays prior to claim construction, noting such cases have “not reached such an advanced stage that it would weigh against a stay.” *Broadphone LLC v. Samsung Elecs. Co.*, No. 2:23-CV-00001-JRG-RSP, 2024 WL 3524022, at \*2-3 (E.D. Tex. July 24, 2024)

(granting stay where “significant amount of discovery remains, the claim construction hearing has not occurred, and trial is currently set for [over six months later]”). Even in cases that are far more advanced, the Eastern District of Texas has granted stays where an IPR has been instituted, recognizing “the PTAB’s insight and expertise ‘is likely to be of considerable assistance to the Court.’” *Onpoint Sys., LLC v. Protect Animals With Satellites, LLC*, No. 4:20-CV-657, 2022 WL 2704166, at \*3-4 (E.D. Tex. July 12, 2022) (citation omitted) (granting stay even where “no dispute that this case is in an advanced stage”); *see also Cywee Grp. Ltd. v. Samsung Elecs. Co.*, No. 17-CV-00140, 2019 U.S. Dist. LEXIS 144149, at \*19-22 (E.D. Tex. Feb. 14, 2019) (granting stay three months prior to scheduled trial date) (collecting cases where the court granted stays despite trial being four or fewer months away). Given the uncertainty of whether the district court will grant a stay in the litigation, this factor does not favor denial of institution.

To the extent the Board finds that ***Factors 2 and 3*** are neutral or at most weigh slightly against institution, they deserve little weight given Samsung’s diligence in preparing and filing this Petition. *Markman* briefing has not commenced; fact discovery is in its infancy (Ex.1050, 4), with iCashe producing less than 12,000 pages (Exs. 1059-60); and no experts have prepared reports (Ex.1050, 3). *See Apple v. Parus Holdings, Inc.*, No. IPR2020-00686, Pap. 9, at 15-17 (aside from initial invalidity contentions, finding “no other significant investment” where no

dispositive motions, expert reports, or *Daubert* challenges occurred). Moreover, although trial is currently set for April 6, 2026, Petitioners expect the district court litigation will be delayed because twelve other active cases are also scheduled for trial on that same date and six of those were filed prior to this litigation. Exs. 1050-58; see *Boe Tech. Grp. Co. v. Optronix Scis. LLC*, No. IPR2024-01130, 2025 WL 305477, at \*4 (*Fintiv* factor 2 “neutral or weigh[s] slightly in favor of not exercising discretion” where Judge Gilstrap “set 10 cases for jury selection on the same day”). The district court has also not issued any substantive orders, including any related to the validity of the ’965.

Petitioners’ diligence averts parallel, duplicative proceedings, and any unfair costs to Patent Owner. *Sotera Wireless, Inc. v. Masimo Corp.*, No. IPR2020-01019, Pap. 12, at 16-17 (precedential as to § II.A); *Apple Inc. v. Maxell, Ltd.*, No. IPR2020-00204, Pap. 11, at 16 (refusing to exercise discretionary denial even where trial would be complete nine months before FWD will issue, district court had already issued claim construction order, fact discovery had closed, and expert discovery was underway); *Lego Sys., Inc. v. Mq Gaming LLC*, No. IPR2020-01445, 2021 WL 606917, at \*8 (granting institution where trial expected to occur “five months before a final written decision,” because outweighed by “low” “investment by the court and parties in the [parallel case] on issues common to this proceeding,” Petitioner’s *Sotera* stipulation “that allays concerns about inefficient duplication of resources

and the potential for inconsistent decisions,” and “the merits of the Petition are strong”); *CoolIT Sys., Inc., v. Asetek Danmark A/S*, No. IPR2021-01195, Pap. 10, at 9-14 (instituting where district court trial was expected to occur five months before Board’s decision, and narrower Sand stipulation filed).

Importantly, fairness considerations weigh in favor of institution under *NHK. Fintiv*, Pap. 11, at 11 (“[E]vidence...that the petitioner filed the petition expeditiously...weigh[] against exercising the authority to deny institution under *NHK.*”). iCashe has asserted multiple patents against Samsung. Samsung diligently investigated and assessed its options for challenging those patents (including the ’965) and had a right to do so before the statutory deadline for pursuing IPR expired. §315(b); *see also Lego*, 2021 WL 606917, at \*5 (finding no delay supporting discretionary denial even where invalidity contentions had been served nearly a year prior, recognizing “preparing a petition for *inter partes* review requires substantial effort even after the references and basic theories have been identified”). This right should not be violated. iCashe’s selection of a venue with an expedited trial schedule should not be rewarded at the expense of Samsung’s rights to pursue review within one year of service of the complaint.

**Factor 4** weighs strongly in favor of institution. Upon institution of this IPR proceeding, Petitioners stipulate that, they will not pursue in *iCashe, Inc. v. Samsung Elecs. Co.*, No. 2:24-cv-00429 (E.D. Tex. filed June 6, 2024), the grounds of

invalidity asserted in the IPR, or any other ground that was raised or could have reasonably been raised in the IPR with respect to the Challenged Claims. *Sotera*, Pap. 12, at 19 (finding “stipulation here mitigates any concerns of duplicative efforts...as well as concerns of potentially conflicting decisions” and “ensures that an *inter partes* review is a ‘true alternative’ to the district court proceeding”); *Lego*, 2021 WL 606917, at \*6 (“[F]actor weighs strongly against discretionary denial” where “Petitioner has agreed to be bound by the same stipulation as in *Sotera*”).

**Factor 5** is either neutral or weighs at most only slightly against institution. Petitioners and Patent Owner are the same parties in the district court litigation. While the overlapping parties may weigh slightly in favor of exercising discretion, institution and a public trial record of the important invalidity grounds in the Petition will reduce issues for the public, including all parties besides Samsung who may in the future be subject to litigation involving the ’965.

**Factor 6** weighs strongly in favor of institution. The Petition is strong and presents compelling unpatentability arguments that were not previously considered during prosecution. The primary reference, **Bangs**, anticipates all Claims and at minimum renders them obvious. See §IX.A. Tentzeris, ¶¶67-176. There is a significant public interest against “leaving bad patents enforceable.” *Thryv, Inc. v. Click-ToCall Techs., LP*, 590 U.S. 45, 55 (2020). Accordingly, the Board should not exercise its discretion to deny institution. §314(a).

## VII. LEVEL OF ORDINARY SKILL IN THE ART

A person of ordinary skill in the art (“POSITA”) would have had a Bachelor’s degree in computer science, computer engineering, electrical engineering, or a similar field, with 2-3 years of experience in smartcards and contactless communications. Additional graduate education could substitute for professional experience, or significant experience in the field could substitute for formal education. This is the appropriate level of skill whether the claims are entitled to priority as of 8/8/2008 or 3/1/2011. Tentzeris ¶¶56-58.

## VIII. CLAIM CONSTRUCTION

Claim terms subject to IPR are to be construed according to the *Phillips* standard applied in district court. §42.100(b). Petitioners apply the plain and ordinary meanings of terms. Tentzeris ¶¶59-60. Only terms necessary to resolve the controversy must be construed.

## IX. GROUNDS OF UNPATENTABILITY

This Petition is supported by the Declaration of Dr. Tentzeris, which describes the prior art’s scope and content at the time of the ’965. Tentzeris ¶¶1-205.

Although the ’965 purports to have invented circuitry for incorporating contactless and smartcard functionality into a mobile device, such a system was already known. Tentzeris ¶65. For example, **Bangs** discloses an NFC-enabled mobile device that includes the claimed arrangement of a smartcard controller,

antenna, amplifier, and transmit circuit (including load modulation and active transmit driver circuit). [0043], [0046]-[0050]. **Kerdraon** discloses an NFC-enabled mobile device comprising a smartcard controller. Kerdraon [0070]. **Koh** similarly discloses an NFC-enabled mobile device with a smartcard controller, and is prior art to the 8/8/2008 date of the earlier '346-App. Koh [0033]. As demonstrated below, the prior art renders the Claims unpatentable. Tentzeris ¶¶65-66.

**A. Ground 1: Bangs (Claims 1-20)**

**1. Overview of Bangs**

**Bangs** discloses an “**NFC communication enabled...mobile telephone**” in

Figure 1:

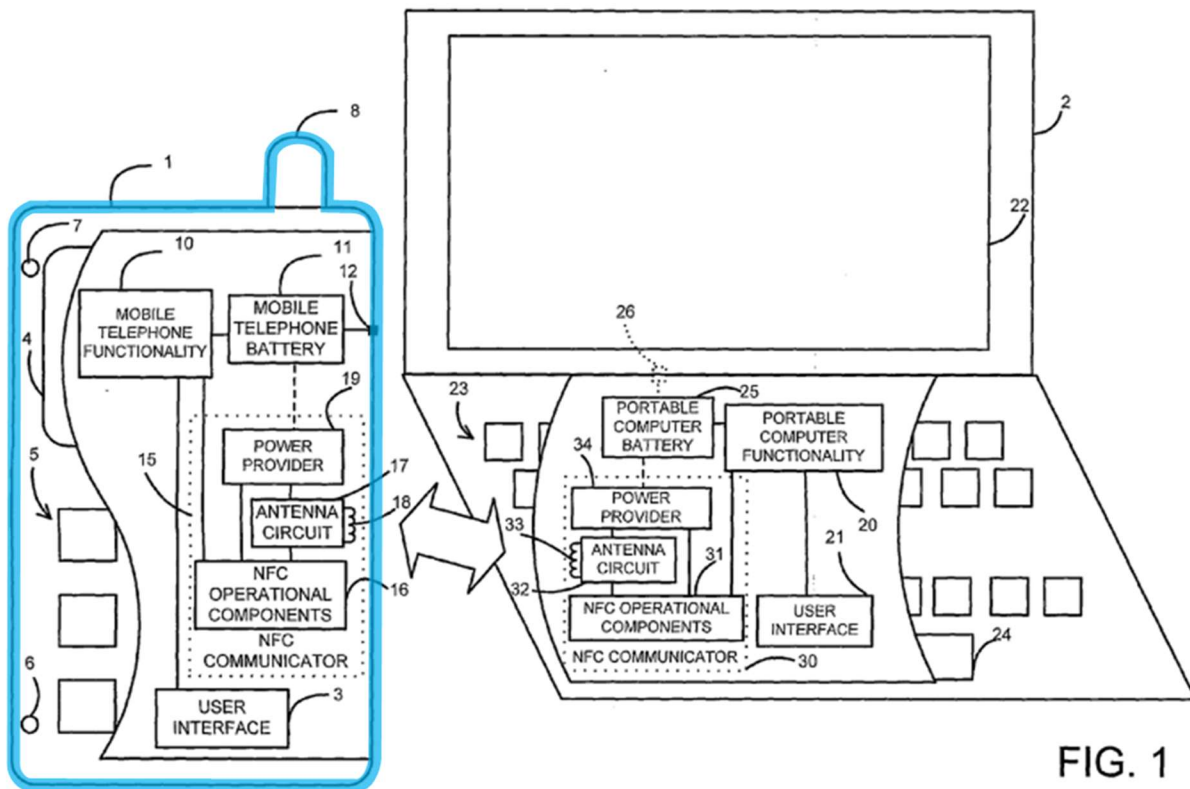

FIG. 1

Bangs [0035], Fig. 1; Tentzeris ¶67.

The NFC functionality of the **mobile phone** is provided by an “NFC communicator 100a,” comprising the “NFC operational components” shown in Figure 2. [0006], [0046]. NFC communicator 100a (in Figure 2) corresponds to NFC communicator 15 of **mobile phone 1** but Figure 2 provides additional functional detail on the “NFC operational components 16 and 31” therein that comprise components providing NFC functionality 120 coupled to antenna circuit 102. [0039], [0046]. Figure 3 further provides additional detail of antenna circuit 102. [0056]-[0057]. Tentzeris ¶68.

The NFC components of the **mobile phone** include “**controller 107**,” “**antenna element 309**,” “**amplifier 119**,” “**resistor 301...in parallel with capacitor 304**” that performs “**load modulation**,” “**signal generator 109**” and “**driver 111**.” [0046], [0049]-[0050], [0057], [0066], [0070], Figs. 2-3. **Controller 107** is a smartcard controller that “control[s] overall operation of the NFC communicator,” which operates “in accordance with” “various standards” for near-field RF communication, such as “ISO/IEC 14443.” [0051], [0052], [0005]. **Controller 107** is coupled to a data store to process and store data “transmitted from and/or...received by” the **NFC-enabled mobile phone**. [0051]. Bangs acknowledges that “[s]ome areas of application are payment systems” for NFC communicators are “payment systems” and “ticketing systems.” [0006]. Tentzeris ¶69.

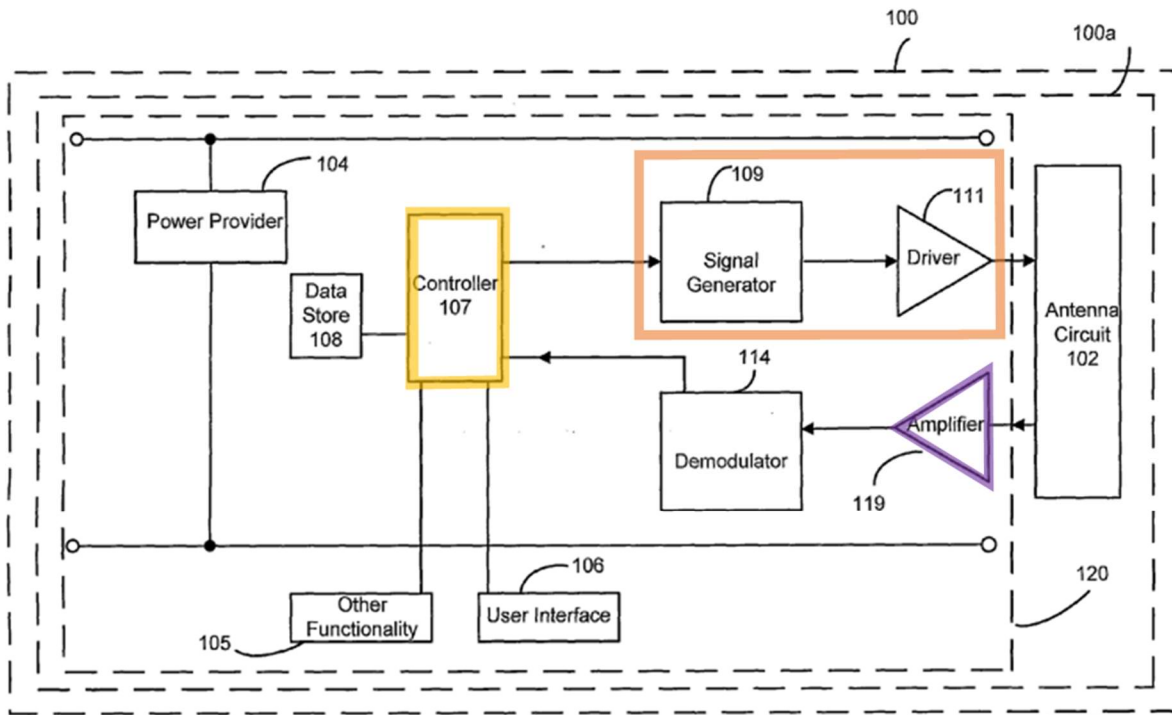

FIG 2.

Fig. 2; Tentzeris ¶169.

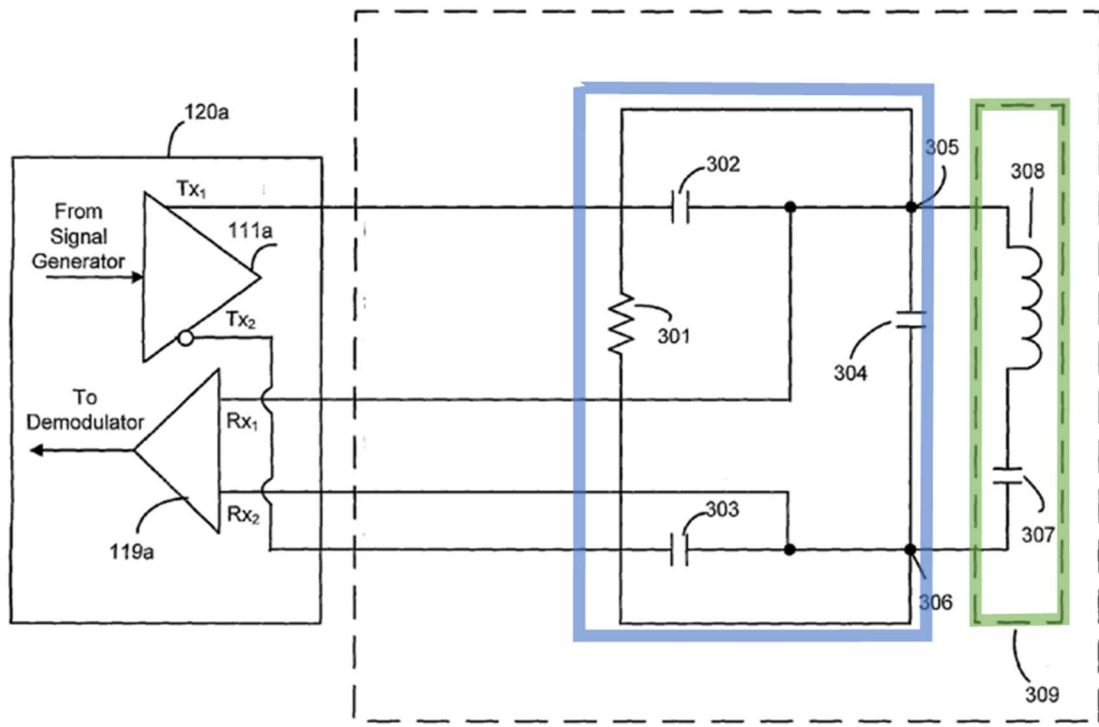

FIG. 3

Fig. 3; Tentzeris ¶69.

As shown in Figures 2-3 above, “**amplifier 119**” is coupled between **antenna element 309** and “demodulator 114 coupled to...**controller 107**” for amplifying the received signal, demodulating the signal to extract data, and “supplying the thus-extracted data to the **controller 107**.” [0049], [0057]-[0059]. Antenna circuit 102 comprising **antenna element 309** is “tuned to...13.56 MHz,” the frequency at which “NFC communicators commonly operate.” [0052], [0057], [0070]. **Amplifier 119** amplifies the received signal, and demodulator 114 demodulates the amplified signal to provide “the thus-extracted data to the **controller 107**.” [0049]. Tentzeris ¶70.

NFC communicator 100a’s “transmitter circuitry” comprises circuitry to effect communication in either a “passive” or “active” mode. [0016], [0050]. For active communication, “**signal generator 109 coupled via...driver 111**” “drive[s] the antenna circuit 102” comprising **antenna element 309** “to initiate or generate an RF-H field.” [0050], [0070]-[0071]. For passive communication, “**resistor 301...coupled in parallel with capacitor 304**” is “switchable to provide...load modulation” of “the RF H field received from that near field RF communicator...with the data to be communicated.” [0060], [0066]-[0067]. Tentzeris ¶71.

**Bangs** discloses the **controller 107**, **amplifier 119**, **signal generator 109**, and **driver 111** are powered by the **mobile phone’s** “battery 11.” [0036], [0047].

Power provider 104, shown in Figure 2 above, comprises “coupling[s] to derive power from...battery 11” and supply it to the NFC communicator components.

[0041], [0047]. Tentzeris ¶¶72.

## 2. Claim Chart

'965 Claim	Bangs
<p>[1.pre]. A mobile device comprising:</p>	<p><b>To the extent the preamble is limiting, Bangs discloses a mobile device (e.g., “mobile telephone”).</b></p> <p><b><u>E.g., Bangs</u></b></p> <p><b>Bangs</b> discloses an “NFC communications enabled device,” such as “mobile telephone 1,” which includes an “NFC communicator 15.” [0006], [0035], [0038], Fig. 1. As further illustrated in the “functional block diagram” of Figure 2, “NFC communications enabled device 100 comprises an NFC communicator 100a,” which contains various “NFC operational components.” [0045]-[0046], Fig. 2. Tentzeris ¶¶74-76.</p> <ul style="list-style-type: none"> <li>• <b>Fig. 1</b></li> </ul> <p style="text-align: right;">FIG. 1</p> <ul style="list-style-type: none"> <li>• <b>Fig. 2</b></li> </ul>



'965 Claim	Bangs
	<p>communications enabled device embodying the invention may be implemented.</p> <ul style="list-style-type: none"> <li>• <b>[0046]:</b> “In this example, <i>the NFC communications enabled device 100 comprises an NFC communicator 100a</i> having NFC operational components....”</li> <li>• <b>[0064]:</b> “[T]he NFC functionality 120a will be formed as one or more integrated circuits.”</li> </ul>
<b>[1.a]</b> a smartcard controller;	<p><b>Bangs discloses a smartcard controller</b> (<i>e.g.</i>, “controller 107” of “NFC communicator” compliant with ISO14443).</p> <p><b><u>E.g., Bangs</u></b></p> <p><i>See [1.pre].</i></p> <p><b>Bangs</b> further discloses “NFC communicator 100a” included in host mobile telephone 1 (<i>see [1.pre]</i>) includes “controller 107...to control overall operation of the NFC communicator,” which operates “in accordance with” “various standards” for near-field RF communication, such as “ISO/IEC 14443.” [0051], [0052], [0005]. For example, Bangs discloses that “controller 107 is coupled to the data store 108 which is provided to store data (information and/or control data) to be transmitted from and/or data received by the NFC communications enabled device,” and that “[s]ome areas of application are payment systems, ticketing systems,” etc. [0051], [0005]-[0006]. Tentzeris ¶¶77-79.</p> <p>In light of the above, a POSITA would have understood that Bangs’ “controller 107” is a smartcard controller,<sup>3</sup></p>

---

<sup>3</sup> The use of a controller that supports the ISO 14443 standard is consistent with the '965 specification and prosecution of the related '722 patent. *See* '965, 8:50-53

'965 Claim	Bangs
	<p>and at minimum would have found it obvious to implement controller 107 as a smartcard controller to advantageously provide smartcard functionality in Bangs' mobile telephone without needing to carry a separate smartcard device. Tentzeris ¶¶80-83<sup>4</sup>.</p> <p>Demodulator 114 “demodulat[es] a modulated RF signal...from another near field RF communicator” and “suppl[ies] the thus-extracted data to controller 107 for processing.” [0049], Fig. 2. To the extent it is argued that the signal provided to the controller cannot be demodulated, controller 107 and demodulator 114 work together to process information in an interrogating field from another RF communicator and thus also collectively form a controller. Tentzeris ¶84.</p> <ul style="list-style-type: none"> <li>• <b>Fig. 2</b></li> </ul>

---

(“smartcard controller 330 may be a device capable of implementing all or part of the ISO 14443 standard for contactless NFC devices.”); Section V.B.2 (Examiner’s uncontested finding during ’722 prosecution that prior art disclosures of a “controller”/“central processor” having ISO 14443-compliant functionality satisfied the claimed “smartcard controller”). Tentzeris ¶80.

<sup>4</sup> Ex.1015, 468 (explaining that smartcard integration in mobile phones “exploits two basic principles of modern society: everyone needs to pay for products and everyday services and just about everyone carries a phone”). Tentzeris ¶83.

'965 Claim	Bangs
	<div data-bbox="565 331 1388 850" data-label="Diagram"> <p style="text-align: right;">FIG. 2.</p> </div> <ul style="list-style-type: none"> <li>• [0005]: “Examples of near field RF communicators are defined in various standards for example ISO/IEC 18092, ISO/IEC 14443, ISO/IEC 15693 ISO/IEC 21481.”</li> <li>• [0006]: “<i>Some areas of application are payment systems, ticketing systems....</i>”</li> <li>• [0049]: “In this example, the receiver circuitry comprises an amplifier 119 coupled to the antenna circuit 102 and <i>a demodulator 114 coupled to the amplifier 119 and the controller 107 for amplifying and demodulating a modulated RF signal</i> inductively coupled to the antenna circuit 102 from another near field RF communicator in near field range and for supplying the thus-extracted data to the controller 107 for processing.”</li> <li>• [0051]: “<i>The controller 107 of the NFC functionality 120 is provided to control overall operation of the NFC communicator. The controller 107 is coupled to the data store 108 which is provided to store data (information and/or control data) to be transmitted from</i></li> </ul>

’965 Claim	Bangs
	<p><i>and/or data received by the NFC communications enabled device....”</i></p> <ul style="list-style-type: none"> <li>• [0052]: “...while when in target mode an NFC communicator waits for a communication from <i>a compatible initiating near field RF communicator</i> (for example an NFC communicator in initiator mode or an RFID initiator or transceiver). As thus used, <i>compatible means</i> operable at the same frequency and <i>in accordance with the same protocols, for example in accordance with the protocols set out in various standards</i> such as ISO/IEC 18092, ISO/IEC 21481, <i>ISO/IEC 14443</i> and ISO/IEC 15693. NFC communicators commonly operate at or around 13.56 MHz.”</li> <li>• [0067]: “In operation of the NFC communicator...when the NFC communicator is acting as a target...<i>the NFC communicator will communicate</i> any response <i>to an initiator near field RF communicator</i> in near field range by modulating the RF H field received from that near field RF communicator <i>under the control of the controller 107....”</i></li> </ul>
<p>[1.b] an antenna; and</p>	<p><b>Bangs discloses an antenna</b> (<i>e.g.</i>, “antenna element 309”).</p> <p><u><i>E.g., Bangs</i></u>  <i>See [1.pre].</i></p> <p><b>Bangs</b> further discloses NFC communicator 100a includes “antenna element 309” in “antenna circuit 102...tuned to...13.56 MHz.” [0057], [0070]; Tentzeris ¶¶85-87.</p> <ul style="list-style-type: none"> <li>• <b>Fig. 3</b></li> </ul>

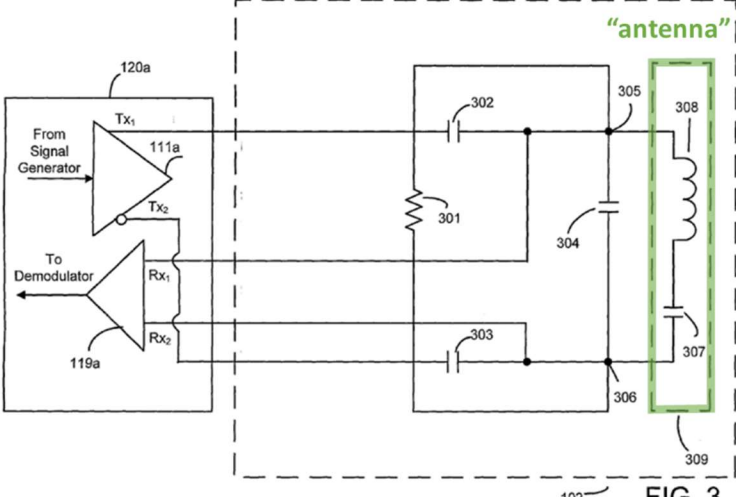
'965 Claim	Bangs
	 <p style="text-align: right;">FIG. 3</p> <ul style="list-style-type: none"> <li>• [0046]: “[T]he NFC communications enabled device 100 comprises an NFC communicator 100a having NFC operational components including an antenna circuit 102....”</li> <li>• [0057]: “As shown in FIG. 3, antenna circuit 102 comprises an antenna element 309 coupled in parallel with a first capacitor 304 to form a tank circuit (a parallel LC resonant circuit).”</li> <li>• [0070]: “When the NFC communicator is in the active communication mode, the controller 107 (FIG. 2) will cause the signal generator 109 (FIG. 2) and driver 111a to drive the antenna circuit 102 to initiate or generate an RF-H field. The antenna circuit 102 is tuned to the required RF transmission frequency which, for an NFC communicator operating in accordance with ISO 18092, is 13.56 MHz (Megahertz). The capacitors 302 and 303 add capacitance to bring the tuning closer to the required frequency.”</li> </ul>
[1.c] performance enhancement circuits coupled between the smartcard controller	<p><b>Bangs discloses performance enhancement circuits coupled between the smartcard controller and the antenna (e.g., circuitry between “antenna element 309” and “controller 107”), wherein the performance</b></p>

'965 Claim	Bangs
<p>and the antenna, wherein the performance enhancement circuits include an amplifier and a load modulation circuit, and</p>	<p><b>enhancement circuits include an amplifier</b> (<i>e.g.</i>, includes “amplifier 119”) <b>and a load modulation circuit</b> (<i>e.g.</i>, “switchable” “resistor 301...in parallel with capacitor 304”).</p> <p><b><u>E.g., Bangs</u></b></p> <p><i>See</i> [1.pre]-[1.b].</p> <p><b>Bangs</b> further discloses circuitry coupling “antenna element 309” to “controller 107.” Bangs [0049], [0057], Figs. 2-3. This circuitry is identified by annotation below in Figures 2 and 3, and includes “amplifier 119,” and “resistor 301...coupled in parallel with capacitor 304” (among other components). [0049], [0060], Figs. 2-3. Tentzeris ¶¶88-91.</p> <p><b>Bangs</b> discloses resistor 301 is “switchable to provide...load modulation.” [0060], [0066], Fig. 3. <b>Bangs</b> explains, “in passive target communication mode,” NFC communicator 100a responds to “an initiator near field RF communicator...by modulating the RF H field received from that near field RF communicator” “us[ing] load modulation.” [0067]. Thus, <b>Bangs</b> discloses switchable resistor 301 coupled in parallel with capacitor 304, which is further in parallel with antenna element 309, is a load modulation circuit. <i>See</i> [0060], [0057]. Tentzeris ¶92.</p> <p>To the extent it is argued that “performance enhancement circuits” require enhancing the distance at which the device can receive and transmit data, the identified circuitry in Figures 2 and 3 below satisfy such a requirement. As illustrated in Figures 2 and 3, <b>Bangs</b> discloses amplifier 119 (for receiving), and signal generator 109 and driver 111 (for transmitting) are coupled between controller 107 and antenna element 309. [0049]-[0050], Figs. 2-3. Tentzeris ¶93. For example, <b>Bangs</b> teaches that amplifier 119 is “for amplifying” an RF signal received from another device inductively</p>

'965 Claim	Bangs
	<p>coupled to the antenna element 309, thereby increasing the distance over which the NFC communicator can receive data. [0049], [0059].<sup>5</sup> Moreover, <b>Bangs</b> teaches that, when transmitting in “active communication mode,” the signal generator 109<sup>6</sup> and driver 111a “drive the antenna circuit 102 to initiate or generate an RF-H field.” [0070]. In doing so, an “RF voltage supplied by driver 111” is applied to the antenna circuit 102 so as to increase “the strength of the induced RF H field.” [0072], Fig. 3. This increase in RF H field strength increases the distance over which data can be transmitted because the distance over which the device can transmit data increases as the signal strength increases. Tentzeris ¶¶93-94.<sup>7</sup></p> <ul style="list-style-type: none"> <li>• <b>Figs. 2-3</b></li> </ul>

<sup>5</sup> See, e.g., Ex.1005 [0101] (describing an RF transponder includes “an amplifier...able to receive even weak signals”). Tentzeris ¶93.

<sup>6</sup> The specification of **Bangs** in one location refers to “signal generator 110,” but this is a typo, and should refer to “signal generator 109.” Bangs [0050]. This occurs only once in **Bangs**, and refers to “the signal generator 110” in the sentence after introducing “a signal generator 109.” Tentzeris ¶94 n.1.

<sup>7</sup> See, e.g., Ex.1019, 12:60–13:6 (describing an RF transceiver “amplify[ing]” transmit signals “for the extra transmission distance”); Ex.1020 [0033] (explaining the distance between two RF devices can be determined by “the total power of the RF transmission signal” from the transmitting device). Tentzeris ¶94.



'965 Claim	Bangs
	<p>supplying the thus-extracted data to the controller 107 for processing.”</p> <ul style="list-style-type: none"> <li data-bbox="602 436 1414 978">• [0050]: “In this example, <i>the transmitter circuitry comprises components for driving the antenna circuit 102 to transmit an RF signal and for modulating an RF signal to enable communication of data</i> between near field RF communicators in near field range. As shown in FIG. 2, the transmitter circuitry comprises a signal generator 109 coupled via a driver 111 to the antenna circuit 102. In this example, <i>the signal generator 110 is configured to cause modulation by gating or switching on and off the RF signal in accordance with the data to be communicated....</i>”</li> <li data-bbox="602 1003 1414 1755">• [0053]: “When in initiator or target mode, <i>the NFC communicator may communicate in accordance with an active or passive protocol.</i> When using an active protocol, the initiating NFC communicator will transmit an RF field and following completion of its data communication will turn off its RF field. The responding near field RF communicator (target) will then transmit its own RF field and data and then turn off its RF field and so on. <i>When using a passive protocol</i> the NFC communicator (initiator) will transmit and maintain its RF field throughout the entire communication sequence and <i>the target will modulate that RF field with the data to be communicated.</i> The protocol used will depend on instructions received from the controller 107 and the response received from a responding near field RF communicator.”</li> <li data-bbox="602 1780 1414 1856">• [0057]: “As shown in FIG. 3, <i>antenna circuit 102 comprises an antenna element 309</i> coupled in</li> </ul>

'965 Claim	Bangs
	<p>parallel with a first capacitor 304 to form a tank circuit (a parallel LC resonant circuit).”</p> <ul style="list-style-type: none"> <li>• [0059]: “The junction 305 between capacitor 304 and <i>antenna element 309 is coupled to</i> one input Rx1 of a differential <i>amplifier 119a</i> forming the amplifier 119 shown in FIG. 2 while the junction 306 between capacitor 304 and antenna element 309 is coupled to the other input Rx2 of the differential amplifier 119a....”</li> <li>• [0060]: “A <i>resistor 301 is coupled in parallel with capacitor 304 between junctions 305 and 306.</i>”</li> <li>• [0066]: “Although the resistor 301 is generally an external component, it may be possible to integrate it. Generally capacitor 307 will have a voltage rating higher than that of the NFC integrated circuit and will therefore not be integrated. It may be possible for <i>resistor 301</i> to be <i>switchable to provide the load modulation.</i>”</li> <li>• [0067]: “In operation of the NFC communicator shown by FIG. 3, <i>when the NFC communicator is acting as a target and is in passive target communication mode, then the NFC communicator will communicate any response to an initiator near field RF communicator in near field range by modulating the RF H field received from that near field RF communicator</i> under the control of the controller 107. The NFC communicator may in these circumstances use load modulation, that is an impedance (not shown) of the NFC functionality may be switched in and out under the control of the controller 107 in accordance with the data to be communicated so as to change the effective impedance of the antenna ‘tank....’”</li> </ul>

'965 Claim	Bangs
	<ul style="list-style-type: none"> <li>• [0070]: “When the <i>NFC communicator is in the active communication mode</i>, the controller 107 (FIG. 2) will cause the <i>signal generator 109 (FIG. 2) and driver 111 a to drive the antenna circuit 102 to initiate or generate an RF-H field</i>. The antenna circuit 102 is tuned to the required RF transmission frequency which, for an NFC communicator operating in accordance with ISO 18092, is 13.56 MHz (Megahertz). The capacitors 302 and 303 add capacitance to bring the tuning closer to the required frequency.”</li> <li>• [0072]: “...Accordingly, capacitors 302 and 303 reduce the total impedance of antenna circuit 102 <i>thereby multiplying the current going to the tank circuit</i> to top up the resonant current flowing through the antenna coil 308 <i>and consequently the strength of the induced RF H field.</i>”</li> <li>• [0074]: “Any appropriate form of modulation may be used to enable data communication, for example <i>modulation of the RF H field may be achieved through gating or switching of the generated signal</i> in accordance with the relevant communication protocols....”</li> <li>• <i>See also</i> [0011]</li> </ul>
<p>[1.d] wherein the amplifier is coupled to amplify a signal received from the antenna and to provide an amplified signal to the smartcard controller.</p>	<p><b>Bangs discloses wherein the amplifier is coupled to amplify a signal received from the antenna</b> (e.g., “amplifier 119...for amplifying” “a modulated RF signal” from “antenna element 309”) <b>and to provide an amplified signal to the smartcard controller</b> (e.g., provides the “amplif[ied]...signal” to “controller 107”).</p> <p><u><i>E.g., Bangs</i></u>  <i>See</i> [1.a]-[1.c].</p> <p><b>Bangs</b> further discloses amplifier 119 “amplif[ies]...a modulated RF signal” received from “antenna element</p>

'965 Claim	Bangs
	<p>309” and the amplified signal is provided to “demodulator 114...coupled to controller 107” (<i>see</i> [1.a]). [0049], [0059], Figs. 2-3. Demodulator 114 demodulates the amplified signal to extract data from the signal and “suppl[ies] the thus-extracted data...to “controller 107” for further processing. [0049]. Tentzeris ¶95-98.<sup>8</sup></p> <p>To the extent it is argued that the amplified signal must be supplied directly to the controller, demodulator 114 coupled to controller 107 collectively satisfy this requirement. Tentzeris ¶99. And to the extent it is argued that the demodulator must be internal to controller 107, this also would have been obvious as doing so amounts to nothing more than reorganizing familiar elements according to known methods to yield predictable results; there is no functional difference between demodulating before or as part of controller 107; and providing demodulation within a controller was known in the art. Tentzeris ¶100.<sup>9</sup> Moreover, <b>Bangs</b></p>

---

<sup>8</sup> This is consistent with the examiner’s uncontested finding during prosecution of a related patent (’722) that Park (Ex.1017) disclosed the same language in [1.d]. *See* §V.B.2; Ex.1017 (disclosing “demodulating the signal amplified by the amplifier 444 to generate the reader reception data and outputting the reader reception data to the controller 130”). ’722FH, 1695; Ex.1017, ¶52; Tentzeris ¶98.

<sup>9</sup> *See, e.g.*, Ex.1021 [0007]–[0009] (discussing an “RFID component” “controller” that provides “demodulation...of data streams into the controller”); Ex.1022 [0043]

'965 Claim	Bangs
	<p>discloses that “equivalents and modifications not described above may also be employed without departing from the scope of the invention.” Bangs [0100]. Tentzeris ¶101.</p> <ul style="list-style-type: none"> <li> <b>Figs. 2-3</b> <p>FIG. 2 is a block diagram of an NFC communicator (100). It includes a smartcard controller (107) connected to a Power Provider (105), a Data Store (108), a Signal Generator (109), a Driver (111), an Antenna Circuit (102), a Demodulator (114), an Amplifier (119), and a User Interface (106). The smartcard controller (107) is highlighted in yellow and has a callout: “provide an amplified signal to the smartcard controller”. The Antenna Circuit (102) is highlighted in green and has a callout: “signal received from the antenna”. The Amplifier (119) is highlighted in purple and has a callout: “amplifier”. FIG. 3 is a detailed view of the Antenna Circuit (102). It shows a transformer (308) with primary windings (305, 307) and secondary windings (302, 304, 306). The transformer is connected to a circuit with a resistor (301) and a capacitor (303). The circuit is connected to a demodulator (119a) and a signal generator (111a). The demodulator (119a) is highlighted in purple and has a callout: “provide...amplified signal to the smartcard controller”. The signal generator (111a) is highlighted in green and has a callout: “signal received from the antenna”.</p> </li> </ul> <ul style="list-style-type: none"> <li> <b>[0001]:</b> “<i>This invention relates to NFC (Near Field Communication) communicators and antenna circuits for NFC communicators.</i>”         </li> </ul>

(“[C]ontroller 308” of RFID device “is capable of properly []demodulating data...received from external devices.”). Tentzeris ¶100.

'965 Claim	Bangs
	<ul style="list-style-type: none"> <li data-bbox="602 331 1416 1010">• <b>[0015]:</b> “An NFC communicator may be battery powered and the desire to minimise power consumption, for example to prolong battery life, can limit the amount of current available to drive the antenna circuit. Also, as indicated above, <i>size or environmental constraints may affect the antenna circuit design</i>, limiting the size and/or topology of the antenna circuit, particularly the antenna coil. All of these factors will have an effect on the RF H field and therefore the voltage developed across an NFC communicator's antenna circuit during communication to the extent that the <i>components of the NFC communicator need to be designed to operate at or need to be protected from voltages much higher than their intended operating voltages.</i>”</li> <li data-bbox="602 1031 1416 1831">• <b>[0028]-[0032]:</b> “<i>FIG. 2 shows</i> a functional block diagram of <i>an example of an NFC communicator</i> or NFC communications enabled device.  <i>FIG. 3 shows</i> a functional circuit diagram of an NFC communicator to illustrate <i>one example of an antenna circuit embodying the present invention;</i>  <i>FIG. 4 shows</i> a functional circuit diagram of an NFC communicator to illustrate <i>another example of an antenna circuit embodying the present invention;</i>  <i>FIG. 5 shows</i> a functional circuit diagram of an NFC communicator to illustrate <i>another example of an antenna circuit embodying the present invention;</i> and  <i>FIG. 6 shows</i> a functional circuit diagram of an NFC communicator to illustrate <i>another example of an antenna circuit embodying the present invention.</i>”</li> </ul>

’965 Claim	Bangs
	<ul style="list-style-type: none"> <li>• [0045]: “<i>FIG. 2</i> shows a functional block diagram of an NFC communications enabled device 100 in accordance with the invention to illustrate in greater <i>detail one way in which the NFC operational components of an NFC communications enabled device embodying the invention may be implemented.</i>”</li> <li>• [0049]: “[T]he receiver circuitry comprises an <i>amplifier 119</i> coupled to the antenna circuit 102 and a demodulator 114 coupled to the amplifier 119 and the controller 107 <i>for amplifying and demodulating a modulated RF signal inductively coupled to the antenna circuit 102 from another near field RF communicator</i> in near field range <i>and for supplying the thus-extracted data to the controller 107</i> for processing.”</li> <li>• [0059]: “The junction 305 between capacitor 304 and <i>antenna element 309 is coupled to one input Rx1 of a differential amplifier 119a forming the amplifier 119</i> shown in FIG. 2 while the junction 306 between capacitor 304 and <i>antenna element 309 is coupled to the other input Rx2 of the differential amplifier 119a....</i>”</li> <li>• [0064]: “Generally, <i>the NFC functionality 120 a will be formed as one or more integrated circuits (generally monocrystalline silicon integrated circuits) mounted on a Printed Circuit Board(s) (PCB(s)) or the like and the antenna circuit will be formed by external discrete components formed on or carried by (e.g. surface mounted on) a PCB</i>, for example the antenna coil element may be defined by conductive tracks on a PCB while any capacitors and resistors of the antenna circuit may be provided by discrete components mounted to the PCB.”</li> </ul>

'965 Claim	Bangs
	<ul style="list-style-type: none"> <li data-bbox="602 331 1398 835">• <b>[0064]:</b> “Generally, <i>the NFC functionality 120 a will be formed as one or more integrated circuits (generally monocrystalline silicon integrated circuits) mounted on a Printed Circuit Board(s) (PCB(s)) or the like and the antenna circuit will be formed by external discrete components formed on or carried by (e.g. surface mounted on) a PCB</i>, for example the antenna coil element may be defined by conductive tracks on a PCB while any capacitors and resistors of the antenna circuit may be provided by discrete components mounted to the PCB.”</li> <li data-bbox="602 856 1406 1457">• <b>[0100]:</b> “The above embodiments are to be understood as illustrative examples of the invention. Further embodiments of the invention are envisaged. It is to be understood that any feature described in relation to any one embodiment may be used alone, or in combination with other features described, and may also be used in combination with one or more features of any other of the embodiments, or any combination of any other of the embodiments. <i>Furthermore, equivalents and modifications not described above may also be employed without departing from the scope of the invention</i>, which is defined in the accompanying claims.”</li> </ul>
<p><b>[2]</b> The mobile device of claim 1 wherein the antenna is tuned to operate at 13.56 MHz.</p>	<p><i>See [1].</i>  <b>Bangs discloses the antenna is tuned to operate at 13.56 MHz</b> (e.g., “antenna element 309” in “antenna circuit...tuned to...13.56 MHz”).  <i>See [1.b].</i> Tentzeris ¶¶102-104.</p>
<p><b>[3]</b> The mobile device of claim 1 wherein the antenna comprises an</p>	<p><i>See [1].</i>  <b>Bangs discloses the antenna comprises an inductive element</b> (e.g., “antenna element 309” comprises “antenna</p>

'965 Claim	Bangs
<p>inductive element too small to draw enough power sufficient to operate the smartcard controller from an interrogating radio frequency (RF) field.</p>	<p>coil element 308”) <b>too small</b> (e.g., “constrain[ed]” by “size limitations” of mobile phone 1) <b>to draw enough power sufficient to operate the smartcard controller from an interrogating radio frequency (RF) field</b> (e.g., such that “controller 107” only “derive[s] power from...battery 11”).</p> <p><b><u>E.g., Bangs</u></b></p> <p><i>See [1.a]-[1.d].</i></p> <p><b>Bangs</b> further discloses “antenna element 309 comprises...antenna coil element 308.” [0057]-[0058], Fig. 3. Antenna coil 308 is an “inductor” to enable inductive coupling with an antenna of another NFC communicator. [0039], [0057]-[0058], Figure 3. Tentzeris ¶¶105-108.</p> <p>A POSITA would have understood, or at minimum found it obvious, that antenna coil element 308 is too small to draw enough power from an interrogating field to operate controller 107. Tentzeris ¶109. <b>Bangs</b> discloses the components of NFC communicator 100a are all powered by battery 11, and not power received from the antenna. Bangs, [0036], [0041], [0047], Fig. 2. Thus, <b>Bangs’</b> antenna does not need to be large enough to power components in the device. In addition, the NFC communication 100a includes the amplifier 119, which is used to amplify the signal obtained using the antenna coil element 308 and provide the signal to the demodulator 114. [0049]. Thus, <b>Bangs’</b> antenna does not need to be large enough to even provide a signal that can be demodulated. Moreover, as <b>Bangs</b> explains in its background section, incorporating NFC communicators into host devices (such as NFC communicator 100a into mobile phone 1) introduces “size limitations of the host” that “constrain the size of...the antenna coil.” Bangs [0010]. <i>See also</i> Bangs [0035], [0038]. In this regard, a POSITA would have recognized that having smaller</p>

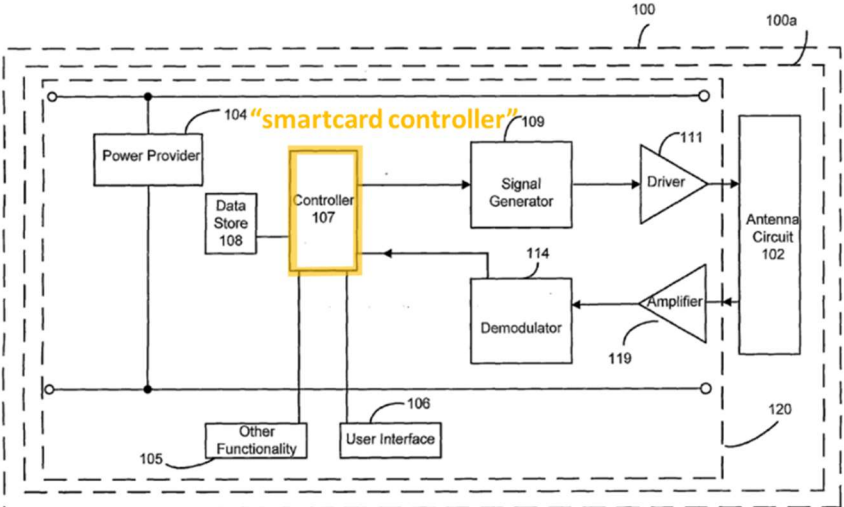
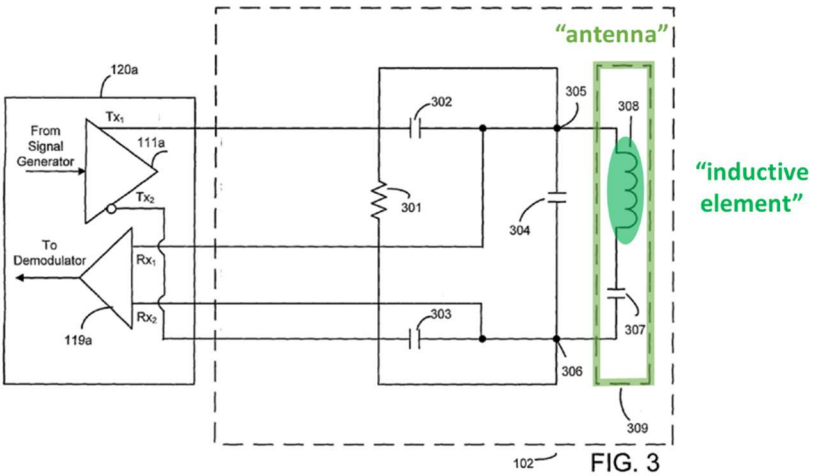
'965 Claim	Bangs
	<p>antennas in a device advantageously allows the host mobile telephone to be more compact and/or allows additional functionality to be added to the device without increasing the size of the mobile telephone. Tentzeris ¶109.</p> <ul style="list-style-type: none"> <li> <b>Fig. 2</b>  </li> <li> <b>Fig. 3</b>  </li> <li> <b>[0004]:</b> "...NFC communicators may also operate in either a "passive communications mode" or an "active communications mode". When communication is by the "passive communications                 </li> </ul>

’965 Claim	Bangs
	<p>mode”, an initiator NFC communicator will generate an RF field and a target NFC communicator will respond by modulation of the received H field, usually by load modulation. When communication is by the “active communications mode” the initiator NFC communicator and the target NFC communicator each use their own RF H field to enable communication. <b><i>The terms “passive” and “active” in the context of NFC communicators do not have the same meaning as “passive” and “active” when used in the context of traditional RFID tags and readers where the terms are instead used to define whether the RFID tags and readers have their own power supply or whether a power supply is derived from the received RF HF field.”</i></b></p> <ul style="list-style-type: none"> <li data-bbox="602 1031 1424 1409">• [0010]: “In addition, where the NFC communicator is within a host device, then <b><i>size limitations of the host and/or the local environment provided by the host may impact on the antenna circuit design and/or constrain the size of the antenna circuit or the antenna coil</i></b> itself. Such impacts and constraints may seriously detrimentally affect the range over which inductive coupling may be achieved.”</li> <li data-bbox="602 1430 1424 1890">• [0015]: “An NFC communicator may be battery powered and the desire to minimise power consumption, for example to prolong battery life, can limit the amount of current available to drive the antenna circuit. Also, as indicated above, size or environmental constraints may affect the antenna circuit design, <b><i>limiting the size and/or topology of the antenna circuit, particularly the antenna coil</i></b>. All of these factors <b><i>will have an effect on the RF H field and therefore the voltage developed across an NFC communicator's</i></b></li> </ul>

’965 Claim	Bangs
	<p><i>antenna circuit</i> during communication to the extent that the components of the NFC communicator need to be designed to operate at or need to be protected from voltages much higher than their intended operating voltages.”</p> <ul style="list-style-type: none"> <li>• [0035]: “As shown in FIG. 1, one NFC communications enabled device comprises a mobile telephone (cellphone) 1 and the other NFC communications enabled device comprises a portable computer 2 such as a notebook or laptop computer.”</li> <li>• [0036]: “...<i>The mobile telephone also has a chargeable battery 11</i> coupled to a charging socket 12 via which a mains adapter (not shown) may be connected to enable charging of the battery 11....”</li> <li>• [0038]: “In addition, as shown in FIG. 1, both <i>NFC communications enabled devices 1</i> and <i>2 have an NFC communicator 15</i> and <i>30</i>. As shown, the NFC communicators 15 and 30 are incorporated within the larger devices and, as with the other functional blocks, may be discrete entities within the host devices or may be provided by features dispersed throughout or integrated within the host device or a part of the host device.”</li> <li>• [0039]: “Each NFC communicator 15 and 30 comprises NFC operational components 16 and 31 for, as will be described below, enabling control of the NFC functionality and generation, modulation and demodulation of an RF signal. Each NFC communicator 15 and 30 also comprises an <i>antenna circuit 17</i> and <i>32 comprising an inductor or coil</i> in the form of an antenna 18 and 33. The antenna circuits 17 and 32 enable an alternating magnetic field (RF H field) generated by the antenna of one near field RF communicator 15 (or</li> </ul>

’965 Claim	Bangs
	<p>30) by transmission of an RF signal (for example a 13.56 Mega Hertz signal) to be inductively coupled to the antenna of the other near field RF communicator 30 (or 15) when that antenna is within the near field of the RF signal generated by the one near field RF communicator 15 (or 30).”</p> <ul style="list-style-type: none"> <li>• <b>[0041]:</b> “<i>Each NFC communicator 15 and 30 also comprises a power provider 19 and 34. The power providers 19 and 34 may be power supplies within the host device or specific to the NFC communicators 15 and 30, for example a button cell battery, or other small battery. As another possibility or additionally as shown by dashed lines in FIG. 1, one or both of the power providers 19 and 34 may simply comprise a coupling to derive power from the corresponding device battery 11 or 25.</i>”</li> <li>• <b>[0047]:</b> “The power provider 104 may be any one or more of the types of power providers discussed above. In the interests of simplicity, <i>power supply couplings from the power provider 104 to other components</i> are not shown <i>in FIG. 2.</i>”</li> <li>• <b>[0049]:</b> “In this example, the receiver circuitry comprises an amplifier 119 coupled to the antenna circuit 102 and a demodulator 114 coupled to the amplifier 119 and the controller 107 for amplifying and demodulating <i>a modulated RF signal inductively coupled to the antenna circuit 102 from another near field RF communicator</i> in near field range and for <i>supplying the thus-extracted data to the controller 107 for processing.</i>”</li> <li>• <b>[0057]:</b> “<i>As shown in FIG. 3, antenna circuit 102 comprises an antenna element 309</i> coupled in parallel with a first capacitor 304 to form a tank circuit (a parallel LC resonant circuit).”</li> </ul>

'965 Claim	Bangs
	<ul style="list-style-type: none"> <li>• [0058]: “The <i>antenna element 309</i> comprises an <i>antenna coil element 308</i> in series with a second capacitor 307 which second capacitor 307 is anti-phase to the antenna coil element 308 and affects a voltage resulting from inductive coupling of an RF H field to the antenna circuit. As shown <i>the antenna coil element 308</i> comprises a <i>single antenna coil</i> which may comprise one, two or more coils or loops.”</li> </ul>
<p>[4] The mobile device of claim 1 wherein the smartcard controller is coupled to be powered by the mobile device.</p>	<p><i>See</i> [1].</p> <p><b>Bangs discloses the smartcard controller is coupled to be powered by the mobile device</b> (<i>e.g.</i>, “controller 107” is “coupl[ed] to derive power from...device battery 11”).</p> <p><u><i>E.g., Bangs</i></u></p> <p><i>See</i> [1.a], [3].</p> <p><b>Bangs</b> further discloses NFC communicator 100a includes “power provider 104” comprising “a coupling to derive power from...battery 11” to provide the power to the components of the NFC communicator (shown in Figure 2). [0041], [0047], Fig. 2. Thus, controller 107 is coupled to device battery 11, via power provider 104, to receive power. Tentzeris ¶¶110-113.</p> <ul style="list-style-type: none"> <li>• <b>Fig. 2</b></li> </ul>

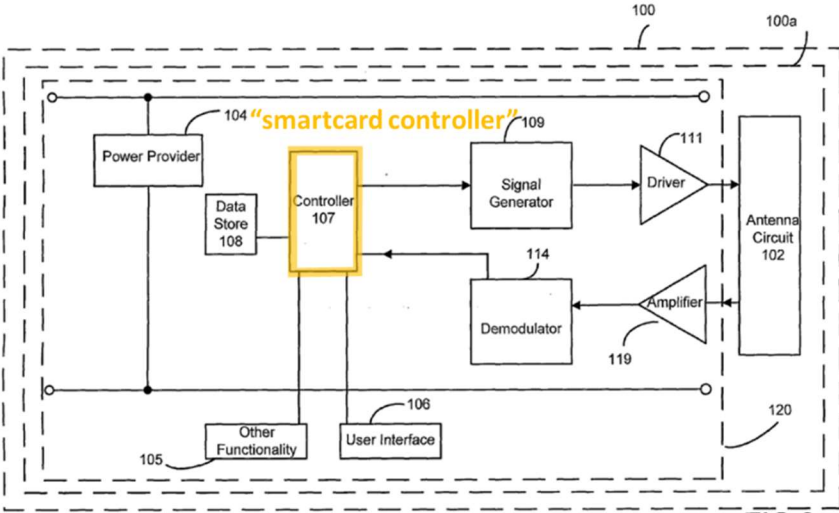
'965 Claim	Bangs
	 <p style="text-align: right;">FIG. 2.</p> <ul style="list-style-type: none"> <li>• [0041]: “Each NFC communicator 15 and 30 also comprises a power provider 19 and 34. The power providers 19 and 34 may be power supplies within the host device.... As another possibility or additionally as shown by dashed lines in FIG. 1, one or both of the power providers 19 and 34 may simply comprise a coupling to derive power from the corresponding device battery 11 or 25.”</li> <li>• [0046]: “In this example, the NFC communications enabled device 100 comprises an NFC communicator 100 a having NFC operational components including an antenna circuit 102 and NFC functionality 120 comprising power provider 104, controller 107, data store 108, receiver circuitry and transmitter circuitry.”</li> <li>• [0047]: “...In the interests of simplicity, power supply couplings from the power provider 104 to other components are not shown in FIG. 2.”</li> </ul>
<p>[5] The mobile device of claim 1 wherein the performance</p>	<p>See [1].</p> <p><b>Bangs discloses the performance enhancement circuits (e.g., circuitry between “antenna element 309” and “controller 107,” see [1.c]) are coupled to be</b></p>

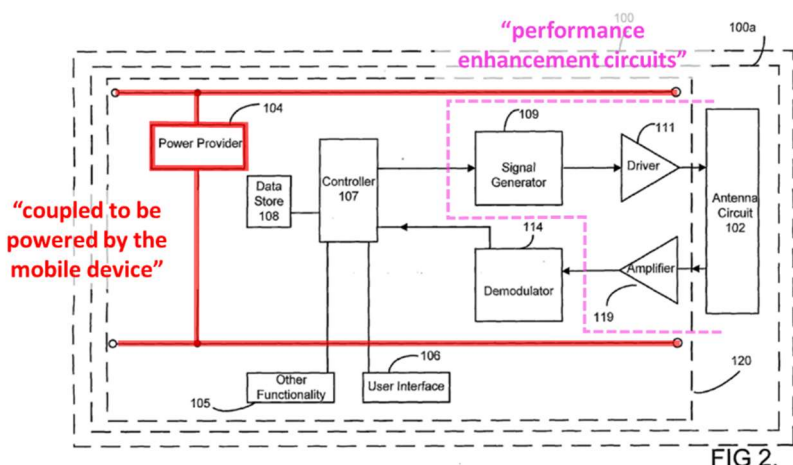
'965 Claim	Bangs
<p>enhancement circuits are coupled to be powered by the mobile device.</p>	<p><b>powered by the mobile device</b> (e.g., “coupl[ed] to derive power from...device battery 11”).</p> <p><b><u>E.g., Bangs</u></b></p> <p>See [1.c]-[1.d], [3]-[4].</p> <p>As discussed for claim [4], <b>Bangs</b> further discloses NFC communicator components are “coupl[ed] to derive power from...device battery 11.” Bangs [0041], [0047], Fig. 2. Thus, the circuitry between antenna element 309 and controller 107 to device battery 11 via power provider 104 to receive power. Tentzeris ¶¶114-117.</p> <ul style="list-style-type: none"> <li>• <b>Figs. 2-3</b></li> </ul>  <p style="text-align: right;">FIG 2.</p>

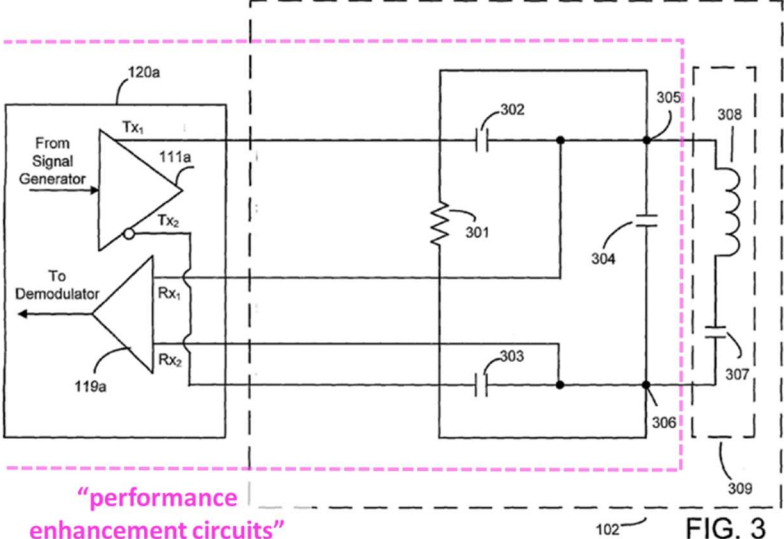
'965 Claim	Bangs
	 <p>The diagram, labeled FIG. 3, shows a transmitter and receiver circuit. On the left, a transmitter stage 120a includes a signal generator connected to a transmitter 111a, which has two output terminals Tx<sub>1</sub> and Tx<sub>2</sub>. A receiver stage 119a includes two input terminals Rx<sub>1</sub> and Rx<sub>2</sub> connected to a demodulator. The transmitter terminals Tx<sub>1</sub> and Tx<sub>2</sub> are connected to the receiver terminals Rx<sub>1</sub> and Rx<sub>2</sub> respectively. Between the transmitter and receiver, there are two performance enhancement circuits, 302 and 303, each consisting of a capacitor and a resistor in series. A central power source 304 is connected to the transmitter and receiver through terminals 305 and 306. An antenna circuit 308 is connected to terminals 305 and 306, and includes an inductor and a capacitor. A dashed line 102 encloses the antenna circuit, and a pink dashed line 104 encloses the performance enhancement circuits. The entire system is labeled 100.</p> <p>“performance enhancement circuits”</p> <p>FIG. 3</p>
	<ul style="list-style-type: none"> <li>• [0041]: “<i>Each NFC communicator 15 and 30 also comprises a power provider 19 and 34. The power providers 19 and 34 may be power supplies within the host device or specific to the NFC communicators 15 and 30, for example a button cell battery, or other small battery. As another possibility or additionally as shown by dashed lines in FIG. 1, one or both of the power providers 19 and 34 may simply comprise a coupling to derive power from the corresponding device battery 11 or 25.</i>”</li> <li>• [0046]: “In this example, <i>the NFC communications enabled device 100</i> comprises an NFC communicator 100 a having NFC operational components including an antenna circuit 102 and NFC functionality 120 <i>comprising power provider 104, controller 107, data store 108, receiver circuitry and transmitter circuitry.</i>”</li> <li>• [0047]: “The power provider 104 may be any one or more of the types of power providers discussed above. In the interests of simplicity, <i>power supply</i></li> </ul>

'965 Claim	Bangs
	<p><i>couplings from the power provider 104 to other components are not shown in FIG. 2.”</i></p> <ul style="list-style-type: none"> <li>• [0057]: “As shown in FIG. 3, antenna circuit 102 comprises an antenna element 309 coupled in parallel with a first capacitor 304 to form a tank circuit (a parallel LC resonant circuit).”</li> </ul>
<p>[6] The mobile device of claim 1 wherein the mobile device comprises a mobile phone.</p>	<p><i>See</i> [1].</p> <p><b>Bangs discloses the mobile device comprises a mobile phone</b> (<i>e.g.</i>, “NFC communications enabled” “mobile telephone”).</p> <p><i>See</i> [1.pre]. Tentzeris ¶¶118-120.</p>
<p>[7.pre] A mobile device comprising:</p>	<p><i>See</i> [1.pre]. Tentzeris ¶¶121-122.</p>
<p>[7.a] a smartcard controller;</p>	<p><i>See</i> [1.a], [7.pre]. Tentzeris ¶¶123-124.</p>
<p>[7.b] an antenna; and</p>	<p><i>See</i> [1.b], [7.pre]. Tentzeris ¶¶125-126.</p>
<p>[7.c] performance enhancement circuits coupled between the smartcard controller and the antenna, wherein the performance enhancement circuits include an amplifier and an active transmit driver circuit, and</p>	<p><b>Bangs discloses performance enhancement circuits coupled between the smartcard controller and the antenna</b> (<i>e.g.</i>, circuitry between “antenna element 309” and “controller 107,” <i>see</i> [1.c]), <b>wherein the performance enhancement circuits include an amplifier</b> (<i>e.g.</i>, “amplifier 119,” <i>see</i> [1.c]) <b>and an active transmit driver circuit</b> (<i>e.g.</i>, “signal generator 109” coupled” to “driver 111” operating “in the active communications mode”).</p> <p><b><u>E.g., Bangs</u></b></p> <p><i>See</i> [1.c], [7.pre]-[7.b].</p> <p><b>Bangs</b> further discloses circuitry coupled between “antenna element 309” and “controller 107” includes “signal generator 109” and “driver 111.” [0050], [0057], Figs. 2-3. Signal generator 109 and driver 111 “drive the antenna circuit 102 to initiate or generate an RF-H field”</p>

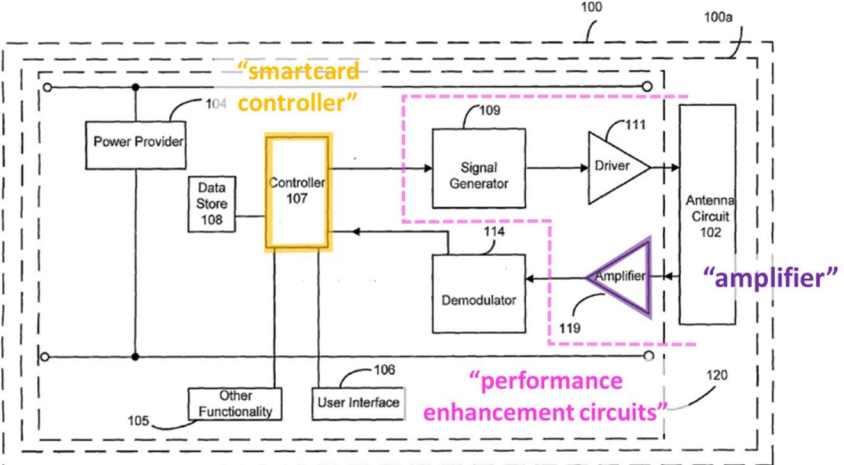
'965 Claim	Bangs
	<p>that is “modulat[ed]...in accordance with the data to be communicated.” [0050], [0070], [0074]. <b>Bangs</b> explains that this is “active communication[,]” because the device is using its “own RF-H field to enable communication.” [0004]. Tentzeris ¶¶127-130.<sup>10</sup></p> <p>As explained in [1.c], to the extent it is argued that “performance enhancement circuits” require enhancing the distance at which the device can receive and transmit data, amplifier 119, signal generator 109, and driver 111 constitute performance enhancement circuits. Tentzeris ¶131.</p> <ul style="list-style-type: none"> <li>• <b>Figs. 2-3</b></li> </ul>  <p style="text-align: right;">FIG 2.</p>

<sup>10</sup> This is consistent with the '965 patent, which discloses that an active transmit driver circuit “include[s] circuits to actively transmit a signal” by “form[ing] a signal that mimics the sidebands...as if the interrogating RF field experienced load modulation.” '965, 16:32–46. Tentzeris ¶130 n.2.

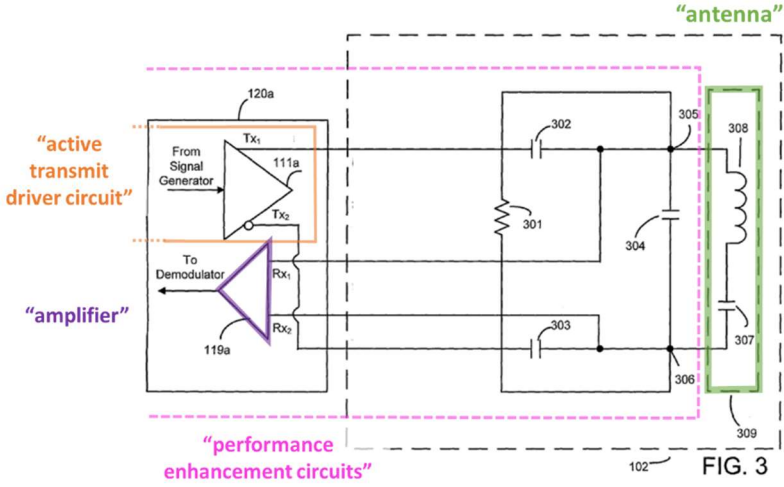
'965 Claim	Bangs
	 <p>FIG. 3</p> <ul style="list-style-type: none"> <li data-bbox="600 850 1396 1312"> <p>[0003]: "...The term 'near field RE [<i>sic</i>: RF] communicator' includes not only NFC communicators but also: <i>initiating near field RF communicators such as RFID transceivers or readers (referred to below as RFID readers)</i> that are capable of initiating a near field RF communication...<i>NFC communicators</i> can act as both RFID transceivers and RFID transponders and <i>are able to communicate with other NFC communicators, RFID transceivers and RFID transponders.</i>"</p> </li> <li data-bbox="600 1333 1412 1837"> <p>[0004]: "...When communication is by the 'passive communications mode', an initiator NFC communicator will generate an RF field and a target NFC communicator will respond by modulation of the received H field, usually by load modulation. <i>When communication is by the 'active communications mode' the initiator NFC communicator and the target NFC communicator each use their own RF H field to enable communication.</i> The terms 'passive' and 'active' in the context of NFC communicators do not...define whether the RFID tags and readers</p> </li> </ul>

'965 Claim	Bangs
	<p>have their own power supply or whether a power supply is derived from the received RF HF field.”</p> <ul style="list-style-type: none"> <li>• [0046]: “[<i>T</i>]he NFC communications enabled device 100 comprises an NFC communicator 100a having...NFC functionality 120 comprising power provider 104, controller 107, data store 108, receiver circuitry and <i>transmitter circuitry</i>.”</li> <li>• [0050]: “[<i>T</i>]he transmitter circuitry comprises components for driving the antenna circuit 102 to transmit an RF signal and for modulating an RF signal to enable communication of data between near field RF communicators in near field range. As shown in FIG. 2, the transmitter circuitry comprises a signal generator 109 coupled via a driver 111 to the antenna circuit 102. In this example, the signal generator 110 is configured to cause modulation by gating or switching on and off the RF signal in accordance with the data to be communicated.”</li> <li>• [0057]: “As shown in FIG. 3, antenna circuit 102 comprises an antenna element 309 coupled in parallel with a first capacitor 304 to form a tank circuit (a parallel LC resonant circuit).”</li> <li>• [0070]: “When the NFC communicator is <i>in the active communication mode</i>, the controller 107 (FIG. 2) will cause <i>the signal generator 109 (FIG. 2) and driver 111a to drive the antenna circuit 102 to initiate or generate an RF-H field</i>. The antenna circuit 102 is tuned to the required RF transmission frequency which, for an NFC communicator operating in accordance with ISO 18092, is 13.56 MHz (Megahertz).”</li> <li>• [0074]: “Any appropriate form of modulation may be used to enable data communication, for example modulation of the RF H field may be</li> </ul>

<b>'965 Claim</b>	<b>Bangs</b>
	<p>achieved through gating or switching of the generated signal in accordance with the relevant communication protocols.... For example, a current drive will control the current supplied to the antenna circuit 102 and may achieve modulation by changing the current. A voltage drive on the other hand will control the voltage supplied to the antenna circuit 102 and may achieve modulation by controlling pulses supplied the antenna circuit 102.”</p>
<p><b>[7.d]</b> wherein the amplifier is coupled to amplify a signal received from the antenna and to provide an amplified signal to the smartcard controller.</p>	<p><i>See</i> [1.d], [7.a]-[7.c]. Tentzeris ¶¶132-133.</p>
<p><b>8.</b> The mobile device of claim 7 wherein the antenna is tuned to operate at 13.56 MHz.</p>	<p><i>See</i> [2], [7]. Tentzeris ¶¶134-135.</p>
<p><b>9.</b> The mobile device of claim 7 wherein the antenna comprises an inductive element too small to draw enough power sufficient to operate the smartcard controller from an interrogating radio frequency (RF) field.</p>	<p><i>See</i> [3], [7]. Tentzeris ¶¶136-137.</p>

<b>'965 Claim</b>	<b>Bangs</b>
<p><b>10.</b> The mobile device of claim 7 wherein the smartcard controller is coupled to be powered by the mobile device.</p>	<p><i>See</i> [4], [7]. Tentzeris ¶¶138-139.</p>
<p><b>11.</b> The mobile device of claim 7 wherein the performance enhancement circuits are coupled to be powered by the mobile device.</p>	<p><i>See</i> [5], [7]. Tentzeris ¶¶140-141.</p>
<p><b>12.</b> The mobile device of claim 7 wherein the mobile device comprises a mobile phone.</p>	<p><i>See</i> [6], [7]. Tentzeris ¶¶142-143.</p>
<p>[13.pre]. A mobile device comprising:</p>	<p><i>See</i> [1.pre]. Tentzeris ¶¶144-145.</p>
<p>[13.a] a smartcard controller;</p>	<p><i>See</i> [1.a], [13.pre]. Tentzeris ¶¶146-147.</p>
<p>[13.b] an antenna;</p>	<p><i>See</i> [1.b], [13.pre]. Tentzeris ¶¶148-149.</p>
<p>[13.c] an amplifier coupled to amplify signals received at the antenna and drive the smartcard controller; and</p>	<p><b>Bangs discloses an amplifier coupled to amplify signals received at the antenna</b> (<i>e.g.</i>, “amplifier 119...for amplifying” “a modulated RF signal” from “antenna element 309,” <i>see</i> [1.d]) <b>and drive the smartcard controller</b> (<i>e.g.</i>, “suppl[ie]d...to the controller 107”).</p> <p><b><u>E.g., Bangs</u></b></p> <p><i>See</i> [1.d], [3], [13.pre]-[13.b].</p>

'965 Claim	Bangs
	<p><b>Bangs</b> further discloses the “[]extracted data” from the “amplif[ied]” signal is supplied to controller 107 for further processing, thereby driving controller 107.<sup>11</sup> [0049]. Tentzeris ¶¶150-153.</p> <p>As explained in [1.d], to the extent it is argued that the signal provided to the controller cannot be demodulated, controller 107 and demodulator 114 collectively form a controller. Moreover, the signal from amplifier 119 is provided directly to demodulator 114, thereby driving demodulator 119. Tentzeris ¶154.</p> <p>And as discussed in [1.d], to the extent it is argued that the demodulator must be internal to controller 107, this also would have been obvious. Tentzeris ¶155.</p> <ul style="list-style-type: none"><li>• <b>Figs. 2-3</b></li></ul>

---

<sup>11</sup> This is consistent with the '965, which discloses only the following operations of an amplifier acting on a received signal: “Amplifier 1510 amplifies the voltage received at antenna 1542, and the amplified voltage is provided to the smartcard controller.” '965, 15:8–10. Moreover, this is consistent with limitation [13.d] (addressed below), which recites “driv[ing] the antenna with data.” '965, cl. 13. Tentzeris ¶153 n.3.

'965 Claim	Bangs
	<p>FIG. 2.</p> <p>FIG. 3</p> <ul style="list-style-type: none"> <li>• [0049]: “In this example, <i>the receiver circuitry comprises an amplifier 119 coupled to the antenna circuit 102 and a demodulator 114 coupled to the amplifier 119 and the controller 107 for amplifying and demodulating a modulated RF signal inductively coupled to the antenna circuit 102 from another near field RF communicator in near field range and for supplying the thus-extracted data to the controller 107 for processing.</i>”</li> </ul>

'965 Claim	Bangs
	<ul style="list-style-type: none"> <li>• [0057]: “As shown in FIG. 3, <i>antenna circuit 102 comprises an antenna element 309</i> coupled in parallel with a first capacitor 304 to form a tank circuit (a parallel LC resonant circuit).”</li> </ul>
<p>[13.d] a driver circuit to drive the antenna with data provided by the smartcard controller.</p>	<p><b>Bangs discloses a driver circuit</b> (<i>e.g.</i>, “transmitter circuitry” including “signal generator 109,” “driver 111,” and “switchable” “resistor 301...in parallel with capacitor 304”) <b>to drive the antenna with data provided by the smartcard controller</b> (<i>e.g.</i>, to “drive...RF current...flow[] through antenna element 309...producing an RF H field” “in accordance with data or instructions from the controller 107”).</p> <p><b><u>E.g., Bangs</u></b></p> <p><i>See</i> [1.a], [7.c], [13.pre]-[13.b].</p> <p><b>Bangs</b> further discloses “transmitter circuitry comprises a signal generator 109” and “driver 111” for “driving the antenna circuit 102,” comprising antenna element 309, “to transmit an RF signal” to another NFC communicator. Bangs [0050], [0057], [0071]. Controller 107 (<i>see</i> [1.a]) provides “data or instructions” to the transmitter circuitry to “cause the signal generator 109...and driver 111a to drive the antenna circuit 102 to initiate or generate an RF-H field.” [0050], [0070]-[0071]. In doing so, the driver 111a drives current through antenna element 309. [0071]. Thus, the transmitter circuitry components drive antenna element 309 with data provided by controller 107. <i>See</i> [0050]. Tentzeris ¶¶156-159.</p> <ul style="list-style-type: none"> <li>• <b>Figs. 2-3</b></li> </ul>

<b>'965 Claim</b>	<b>Bangs</b>
-------------------	--------------

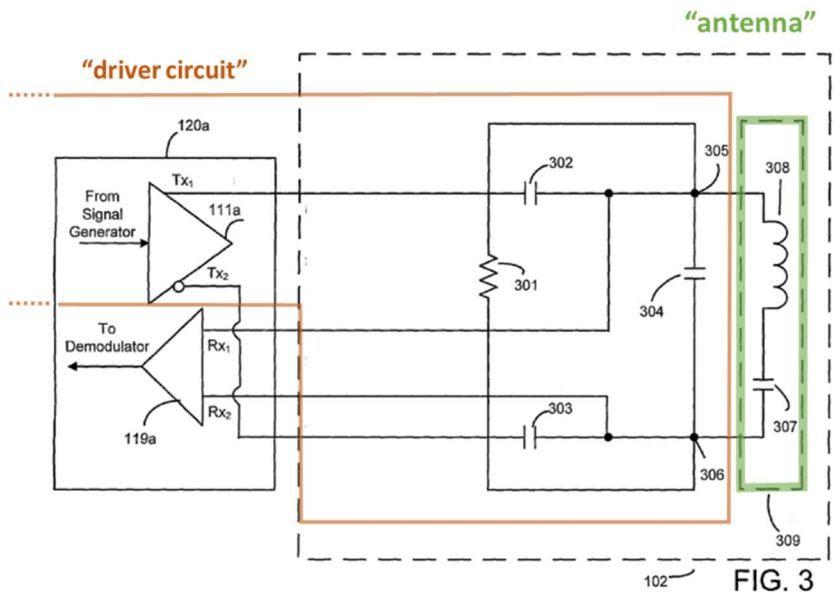
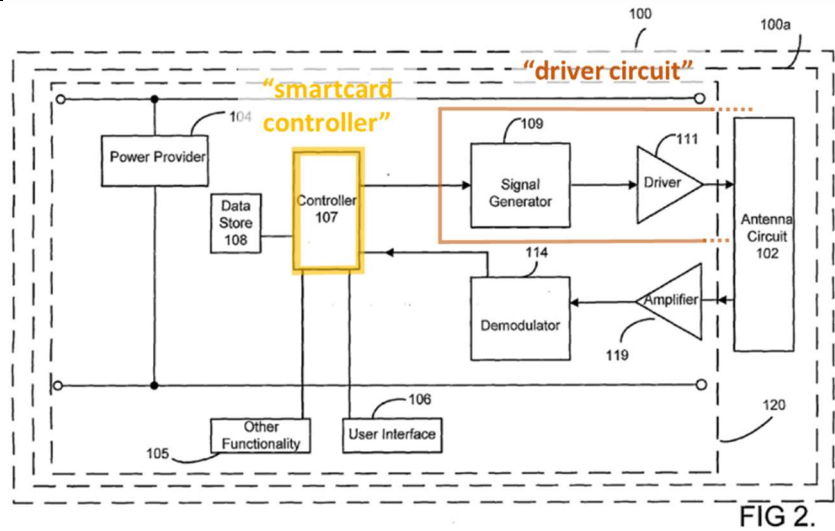

- [0050]: “In this example, *the transmitter circuitry comprises components for driving the antenna circuit 102 to transmit an RF signal* and for modulating an RF signal to enable communication of data between near field RF communicators in near field range. As shown in FIG. 2, *the transmitter circuitry comprises a signal generator 109 coupled via a driver 111 to the antenna circuit 102.* In this example, the signal generator

’965 Claim	Bangs
	<p>110 is configured to cause modulation by gating or switching on and off the RF signal in accordance with the data to be communicated. The NFC communicator may use any appropriate modulation scheme that is in accordance with the standards and/or protocols under which the NFC communicator operates. Alternatively a separate or further signal controller may be incorporated within the NFC operational components of functionality 120 to control modulation of the signal generated by the signal generator 109 in accordance with data or instructions received from the controller 107.”</p> <ul style="list-style-type: none"> <li>• [0057]: “As shown in FIG. 3, <i>antenna circuit 102 comprises an antenna element 309</i> coupled in parallel with a first capacitor 304 to form a tank circuit (a parallel LC resonant circuit).”</li> <li>• [0066]: “Although the resistor 301 is generally an external component, it may be possible to integrate it. Generally capacitor 307 will have a voltage rating higher than that of the NFC integrated circuit and will therefore not be integrated. <i>It may be possible for resistor 301 to be switchable to provide the load modulation.</i>”</li> <li>• [0070]: “When the NFC communicator is in the active communication mode, the controller 107 (FIG. 2) will cause <i>the signal generator 109 (FIG. 2) and driver 111a to drive the antenna circuit 102</i> to initiate or generate an RF-H field. The antenna circuit 102 is tuned to the required RF transmission frequency which, for an NFC communicator operating in accordance with ISO 18092, is 13.56 MHz (Megahertz). The capacitors 302 and 303 add capacitance to bring the tuning closer to the required frequency.”</li> </ul>

’965 Claim	Bangs
	<ul style="list-style-type: none"> <li>• [0071]: “The <i>drive signal from the driver 111 a is coupled to the antenna coil 308</i> via capacitors 302 and 303. The <i>driver 111 a thus develops an RF voltage across transmission connections Tx1 and Tx2 which causes an RF current to</i> flow between transmission connections Tx1 and Tx2 through antenna circuit 102. As this RF current flows between points 306 and 305, it <i>divides between resistor 301, capacitor 304 and antenna element 309 in accordance with their relative impedances</i>. The portion of the RF current <i>that flows through antenna element 309 passes through antenna coil 308 producing an RF H field.</i>”</li> <li>• [0074]: “<i>Any appropriate form of modulation may be used to enable data communication</i>, for example modulation of the RF H field may be achieved through gating or switching of the generated signal in accordance with the relevant communication protocols. The form of modulation <i>will depend on the type of drive functionality incorporated within the NFC communicator. For example, a current drive will control the current supplied to the antenna circuit 102 and may achieve modulation by changing the current. A voltage drive on the other hand will control the voltage supplied to the antenna circuit 102 and may achieve modulation by controlling pulses supplied the antenna circuit 102.</i> Any suitable type of modulation technique may be used (e.g. amplitude and/or phase modulation) and any suitable modulation encoding scheme may be used.”</li> </ul>
<p>[14] The mobile device of claim 13 wherein the driver circuit comprises a</p>	<p>See [13].</p> <p><b>Bangs discloses the driver circuit</b> (e.g., “transmitter circuitry,” see [13.d]) <b>comprises a load modulation</b></p>

'965 Claim	Bangs
load modulation circuit.	<b>circuit</b> (e.g., “switchable” “resistor 301...in parallel with capacitor 304,” <i>see</i> [1.c]).  <b><u>E.g., Bangs</u></b> <i>See</i> [1.c], [13.d]. Tentzeris ¶¶160-162.
[15] The mobile device of claim 13 wherein the driver circuit comprises an active transmit driver circuit.	<i>See</i> [13]. <b>Bangs discloses the driver circuit</b> (e.g., “transmitter circuitry,” <i>see</i> [13.d]) <b>comprises an active transmit driver circuit</b> (e.g., “compris[ing] a signal generator 109 coupled” to “driver 111” for “active communication,” <i>see</i> [7.c]). <i>See</i> [13.d], [7.c]. Tentzeris ¶¶163-165.
[16] The mobile device of claim 15 wherein the active transmit driver circuit is coupled to be powered by the mobile device.	<i>See</i> [15]. <b>Bangs discloses the active transmit driver circuit</b> (e.g., “signal generator 109 coupled” to “driver 111” for “active communication,” <i>see</i> [15]) <b>is coupled to be powered by the mobile device</b> (e.g., “coupl[ed] to derive power from...device battery 11,” <i>see</i> [11]). <i>See</i> [7.c], [11], [15]. Tentzeris ¶¶166-168.
[17] The mobile device of claim 13 wherein the amplifier is coupled to be powered by the mobile device.	<i>See</i> [1.c]-[1.d], [5], [13]. Tentzeris ¶¶169-170.
[18] The mobile device of claim 13 wherein the antenna is tuned to operate at 13.56 MHz.	<i>See</i> [13], [2], [8]. Tentzeris ¶¶171-172.
[19] The mobile device of claim 13 wherein the antenna	<i>See</i> [13], [3], [9]. Tentzeris ¶¶173-174.

'965 Claim	Bangs
comprises an inductive element too small to draw enough power sufficient to operate the smartcard controller from an interrogating radio frequency (RF) field.	
[20] The mobile device of claim 13 wherein the mobile device comprises a mobile phone.	<i>See</i> [13], [6], [12]. Tentzeris ¶¶175-176.

**B. Ground 2: Bangs in View of Kerdraon (Claims 1–20)**

To the extent it is argued that further disclosure of a smartcard controller is required, **Kerdraon discloses a smartcard controller** (*e.g.*, “smart card controller”) as recited in each claim. [0070]-[0071]. Tentzeris ¶177.

**Kerdraon** discloses “mobile terminal 21 including...a near-field communication (NFC) module 29,” “antenna 31,” and “**a Smart MX card component 33**,” which “is a **smart card controller**” that controls NFC module 29. [0070]-[0071], [0077]-[0078], Fig. 4. Near-field communication module 29 “enables near-field communication via the antenna 31 between the mobile terminal 21 and an external reader.” [0078]. Tentzeris ¶178.

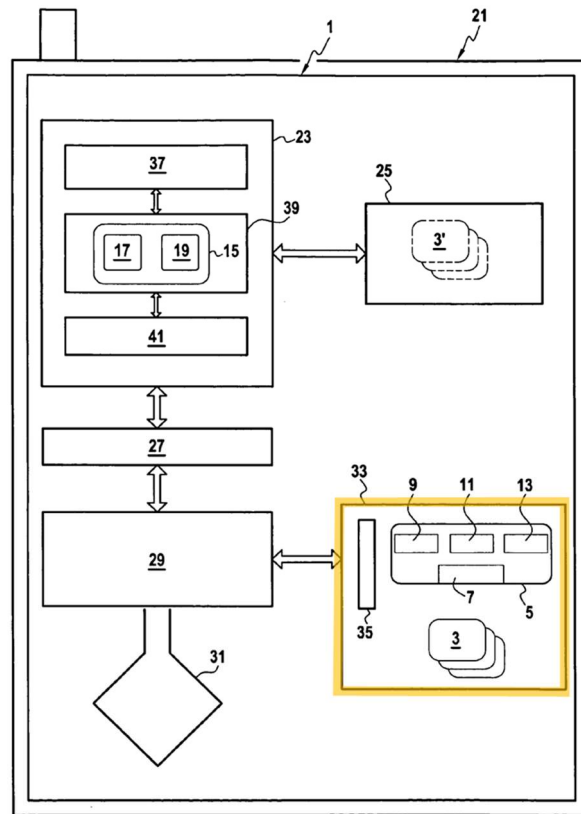

FIG.4

Kerdraon, [0069], Fig. 4; Tentzeris ¶178.

**Smart MX smartcard controller 33** implements a smartcard operating system “such as Java Open Platform” to “store[] Java Card applications,” “partner applications,” “and the relevant data” for the applications. [0071], [0073]. For example, a smartcard application may offer a “payment service.” [0067]. **Smart MX smartcard controller 33** is further compatible with “ISO 14443...interfaces.”

[0071];<sup>12</sup> Tentzeris ¶179.

**Bangs** and **Kerdraon** are analogous art, because they are in the same field as the '965, which includes contactless communications devices, and are reasonably pertinent to alleged problems addressed by the '965, including incorporating contactless communication and smartcard functionality into a mobile device. *See, e.g.,* '965, 1:6-8, 1:61-2:45, 11:10-15, Figs. 14-15, 17, 19, 21-36, 39; Tentzeris ¶¶180-181. For example, both **Bangs** and **Kerdraon** discuss contactless communications devices, such as NFC-enabled devices. *See, e.g.,* Bangs, [0001], [0005], [0036]-[0038], [0052], cl. 44; Kerdraon, [0046], [0069]-[0071], [0078]. Tentzeris ¶¶182-183. And both **Bangs** and **Kerdraon** are pertinent to the alleged problems addressed by the '965, including incorporating contactless communication functionality, including smartcard functionality, into a mobile device. *See, e.g.,* Bangs, [0005], [0006], [0010], [0016]; Kerdraon, [0001]-[0006], [0046], [0070]-[0071]. Tentzeris ¶184.

---

<sup>12</sup> This is consistent with the '965's disclosure of "smartcard controller." '965, 8:44–61 ("The 'SmartMX' family of controllers available from NXP Semiconductors N.V. of The Netherlands are examples of suitable dual interface smartcard controllers."). Tentzeris ¶179 n.4.

A POSITA would have been motivated to apply **Kerdraon's** smartcard controller teachings to **Bangs'** NFC-enabled mobile phone to advantageously provide smartcard functionality in a mobile phone and eliminate a user's need to carry a separate smartcard device. Users regularly engage in secure transactions requiring authentication and regularly carry a mobile phone. *See* Ex.1015, 468. Tentzeris ¶185. Instead of carrying a separate device for authentication, *e.g.*, a credit card, access card, or ID card, storing and managing security data and applications on a smartcard controller hosted on a mobile phone provides the same authentication services through applications on a single device—the mobile terminal. *See* Ex.1015, 468 (explaining that integrating smartcard functions in mobile phones “exploits two basic principles of modern society: everyone needs to pay for products and everyday services and just about everyone carries a phone”); Kerdraon [0008] (stating the described invention offers “access to a plurality of applications stored in the mobile terminal”), [0027] (explaining an application may “stor[e] information relating to transactions effected by users via their mobile terminal”). Tentzeris ¶185. In applying these teachings to **Bangs**, Bangs' controller 107, as modified with **Kerdraon's** smartcard controller teachings, would be coupled to device battery 11 via power provider 104 to receive power as discussed in [4] and [10] (*see* § IX.A.2). Tentzeris ¶185.

Moreover, a POSITA would have further been motivated to include smartcard functionality into a mobile phone because it allows a user to view information about the smartcard and update information stored in the smartcard using the phone functionality. Ex.1023, 2:21-29 (explaining integration of smartcard functionality provides “the ability to read and access information stored within the smartcard by utilizing the cellular telephone display” and “the ability to update/change information stored within the smartcard by utilizing the cellular telephone functions”). Tentzeris ¶186.

Because **Bangs** already teaches controller 107 accesses and manages stored data (Bangs [0049], [0067]), implementing **Kerdraon’s** smartcard controller teachings in **Bangs’** NFC-enabled mobile phone would have been a straightforward modification. Similar to **Bangs’** controller, which accesses and manages stored data, **Kerdraon** teaches a smartcard controller likewise accesses and manages stored data, but the data relates to smartcard functions, *e.g.*, “Java Card application...Cardlets.” [0071], [0073]. A POSITA would have understood that **Bangs’** controller 107 may be implemented with application specific smartcard functions, as taught by **Kerdraon**. Thus, a POSITA would have found it straightforward and advantageous to apply **Kerdraon’s** smartcard controller teaching to **Bangs’** NFC-enabled mobile phone, and would have known such a combination (yielding the claimed limitations) would predictably work and provide the expected functionality. Tentzeris ¶187.

**C. Ground 3: Bangs in View of Koh (Claims 1–20)**

To the extent it is argued the '965 patent is entitled to claim priority to August 8, 2008, the Claims are rendered obvious by **Bangs** in view of **Koh**. Tentzeris ¶188.

As set forth for Ground 1, **Bangs** discloses an NFC-enabled phone and operational components that provide the NFC functionality. **Koh discloses a smartcard controller** (e.g., “Smart MX (SMX) module”) as recited in each claim. Koh, [0033]. Tentzeris ¶189.

**Koh** discloses “a near field communication (NFC) enabled cellphone that includes a Smart MX (SMX) module.” [0033]. **Koh’s** SmartMX module, which is described as a “smart card module,” is a smartcard controller. [0033]. For example, the '965 admits that “[t]he ‘SmartMX’ family of controllers available from NXP Semiconductors N.V. of The Netherlands are examples of suitable dual interface smartcard controllers.” '965, 8:48-61. Moreover, **Koh** explains SmartMX “is preloaded with...JCOP 4.1,” a smartcard controller operating system. Koh [0032]; *See, e.g.*, Ex.1015, 468-69 (explaining the Smart MX “Smart card IC” uses a “JCOP operating system (Java Card Open Platform)”); Ex.1026, [0040] (describing “smart card controller solution[s]...run versatile, open application environment[s] such as Java Card”). Tentzeris ¶190.

Like **Bangs**, **Koh** is analogous art, in the same field as the '965, which includes contactless communications devices, and is reasonably pertinent to alleged

problems identified in the '965, including incorporating contactless communication and smartcard functionality into a mobile device. *See* §IX.B. Tentzeris ¶191. For example, **Koh** discusses contactless communications devices, such as NFC-enabled devices. *See, e.g., Koh*, [0001]-[0002], [0010], [0033]. Tentzeris ¶192. Additionally, **Koh** is pertinent to the alleged problems addressed by the '722, including incorporating contactless communication functionality, including smartcard functionality, into a mobile phone. *See, e.g., Koh*, [0002], [0003]-[0006], [0012], [0010], [0032]-[0033], [0040], Fig. 2. Tentzeris ¶193.

A POSITA would have been motivated to apply **Koh's** smartcard controller teachings to **Bangs'** NFC-enabled mobile phone to advantageously eliminate the user's need to carry a separate smartcard device to use smartcard functionality. Users regularly engage in secure transactions requiring authentication and regularly carry a mobile phone. *See Ex.1015*, 468. Tentzeris ¶194. Instead of carrying a separate device for authentication, *e.g., a credit card, access card, or ID card*, storing and managing security data and applications on a smartcard controller hosted on a mobile phone provides the same authentication services through applications on a single device—the mobile terminal. *See Ex.1015*, 468 (explaining that smartcard integration in mobile phones “exploits two basic principles of modern society: everyone needs to pay for products and everyday services and just about everyone carries a phone”). Tentzeris ¶194. Moreover, a POSITA would have further been

motivated to include smartcard functionality in a mobile phone because it allows a user to view information about the smartcard and update information stored in the smartcard using the phone functionality. Ex.1023, 2:21-29 (explaining integration of smartcard functionality provides “the ability to read and access information stored within the smartcard by utilizing the cellular telephone display” and “the ability to update/change information stored within the smartcard by utilizing the cellular telephone functions”). Tentzeris ¶194.

Because **Bangs** already teaches that controller 107 performs generic controller functions, including “processing” requests received from another component and accessing “store[d] data” to provide a “response” (Bangs [0049]-[0051]), it would have been straightforward to apply **Koh’s** smartcard controller teachings to **Bangs** mobile device. See Bangs [0049], [0067]. Tentzeris ¶195. **Koh’s** SmartMX smartcard controller “stor[es] values” and “run[s] Java applets” effecting smartcard functionality. Koh [0033]. Similar to **Bangs’** controller, which processes requests and provides responses, **Koh** teaches a smartcard controller likewise processes requests and provides responses, and does so for smartcard applications, e.g., to effect mobile payments. Bangs [0049], [0067]; Koh [0053]. A POSITA would have understood, and at a minimum found it obvious, to implement **Bangs’** controller 107 with application specific smartcard functions, as taught by **Koh**. As such, a POSITA would have found it straightforward and advantageous to apply **Koh’s** smartcard

controller teachings to **Bangs'** NFC-enabled mobile phone and would have known such a combination (yielding the claimed limitations) would predictably work and provide the expected functionality. Tentzeris ¶195.

## **X. SECONDARY CONSIDERATIONS**

There is no evidence in the '965's prosecution history or elsewhere supporting any secondary considerations arguments, or evidence of nexus to any challenged Claim. *See generally* '965FH. Indeed, as demonstrated by the prior art referenced herein, any purported solutions to problems or unexpected results in the '965 were already well known. *Id.* ; Tentzeris ¶¶196-197.

To the extent that PO contends that the accused products in the Texas Case are infringing and thus demonstrate commercial success, any such conclusory allegations would fail to provide any indication that the Claims are non-obvious. Such conclusory assertions would not demonstrate that Samsung's products infringe, let alone show any nexus between any alleged commercial success and the Claims, or that any alleged success is due to an allegedly claimed component instead of the many unclaimed features of the accused products. Tentzeris ¶198.

To the extent PO asserts the existence of any secondary considerations in its responses, Petitioners reserve the right to address any such evidence. Tentzeris ¶199.

## **XI. CONCLUSION**

Substantial, new, and noncumulative technical teachings have been presented for each Challenged Claim, which are anticipated and rendered obvious for the reasons set forth above. Tentzeris ¶¶200-205. There is a reasonable likelihood Petitioners will prevail as to each of these Claims. *Inter partes* review of Claims 1-20 of the '965 is accordingly requested.

Dated: March 11, 2025

Respectfully submitted,

By: / James L. Davis, Jr. /

Name: James L. Davis, Jr.

Registration No. 57,325

**ROPES & GRAY LLP**

*Lead Counsel for Petitioners*

**CERTIFICATE OF COMPLIANCE**

Pursuant to 37 C.F.R. § 42.24(a) and (d), the undersigned hereby certify that the Petition For *Inter Partes* Review complies with the type-volume limitation of 37 C.F.R. § 42.24(a)(i) because, exclusive of the exempted portions, it contains 13,278 words as counted by the word processing program used to prepare the paper.

Dated: March 11, 2025

/ James L. Davis, Jr. /

Name: James L. Davis, Jr.

Registration No. 57,325

**ROPES & GRAY LLP**

**CERTIFICATE OF SERVICE**

I hereby certify that on March 11, 2025, I caused a true and correct copy of the foregoing Petition for *Inter Partes* Review of U.S. Patent No. 9,122,965 and supporting exhibits to be served via express mail on the Patent Owner at the following correspondence address of record as listed on Patent Center:

**35781 - Tyfone, Inc.**  
Patent Dept.  
5331 SW Macadam Avenue  
Suite 251  
Portland, OR 97239  
UNITED STATES

---

A courtesy copy was also sent via electronic mail to Patent Owner's litigation counsel at the following addresses:

Fahrenkrog, Aaron R. [AFahrenkrog@RobinsKaplan.com](mailto:AFahrenkrog@RobinsKaplan.com);  
Drew, Logan J. [LDrew@RobinsKaplan.com](mailto:LDrew@RobinsKaplan.com);  
Tremblay, Emily J. [ETremblay@RobinsKaplan.com](mailto:ETremblay@RobinsKaplan.com);  
Jones, William R. [WJones@RobinsKaplan.com](mailto:WJones@RobinsKaplan.com);  
Viswanathan, Prateek N. [PViswanathan@RobinsKaplan.com](mailto:PViswanathan@RobinsKaplan.com);  
Schmeckpeper, Kia Y. [KSchmeckpeper@RobinsKaplan.com](mailto:KSchmeckpeper@RobinsKaplan.com);  
Andrea Fair [andrea@millerfairhenry.com](mailto:andrea@millerfairhenry.com);  
Gutierrez, Jessica L. [JGutierrez@RobinsKaplan.com](mailto:JGutierrez@RobinsKaplan.com)

---

Dated: March 11, 2025

By: /James L. Davis, Jr./  
Name: James L. Davis, Jr.  
Registration No. 57,325  
Counsel for Petitioners