

**IN THE UNITED STATES DISTRICT COURT  
FOR THE WESTERN DISTRICT OF TEXAS  
AUSTIN DIVISION**

INTELLECTUAL VENTURES II LLC,

Plaintiff,

v.

TESLA, INC.,

Defendant.

Civil Action No. 1:24-cv-884-ADA

JURY TRIAL DEMANDED

**TESLA, INC.'S OPENING CLAIM CONSTRUCTION BRIEF**

**TABLE OF CONTENTS**

I. INTRODUCTION ..... 1

II. OVERVIEW OF ASSERTED PATENTS ..... 2

    A. The '639 Patent ..... 2

    B. The '805 Patent ..... 2

    C. The '395 Patent ..... 3

    D. The '416 Patent ..... 5

III. LEGAL STANDARDS ..... 5

    A. Claim Construction ..... 5

    B. Indefiniteness ..... 6

IV. LEVEL OF ORDINARY SKILL IN THE ART ..... 6

V. AGREED CONSTRUCTIONS ..... 7

    A. '743 Patent ..... 7

    B. '158 Patent ..... 7

VI. DISPUTED TERMS ..... 8

    A. “said target feature information” ('639 patent, claim 1) / “said feature information” ('639 patent, claim 7) ..... 8

    B. “may at least partially describe a potential destination” ('805 patent, claim 1) ..... 12

    C. “potential geometric objects for plausibility using a matching algorithm so as to identify one or more plausible objects” ('805 patent, claim 1) ..... 16

    D. “said processing” ('395 patent, claim 1) ..... 18

    E. “broadcast information” ('416 patent, claim 1) ..... 24

VII. CONCLUSION ..... 27

**TABLE OF AUTHORITIES**

<b>Cases</b>	<b>Page(s)</b>
<i>24/7 Customer, Inc. v. LivePerson, Inc.</i> , 235 F. Supp. 3d 1102 (N.D. Cal. 2016) .....	11
<i>Arthur A. Collins, Inc. v. N. Telecom Ltd.</i> , 216 F.3d 1042 (Fed. Cir. 2000).....	26
<i>Berkheimer v. HP Inc.</i> , 881 F.3d 1360 (Fed. Cir. 2018).....	12
<i>Bushnell Hawthorne, LLC v. Cisco Sys., Inc.</i> , 813 F. App'x 522 (Fed. Cir. 2020) .....	6, 18
<i>Cellular Commc'ns Equip. LLC v. AT&amp;T, Inc.</i> , No. 2:15-cv-576, 2016 WL 7364266 (E.D. Tex. Dec. 19, 2016) .....	11
<i>Chef Am., Inc. v. Lamb-Weston, Inc.</i> , 358 F.3d 1371 (Fed. Cir. 2004).....	9
<i>In re Downing</i> , 745 F. App'x 988 (Fed. Cir. 2018) .....	19
<i>eCardless Bancorp, Ltd. v. PayPal Inc.</i> , No. 24-cv-01054, 2024 WL 4804975 (N.D. Cal. Nov. 14, 2024) .....	19
<i>Fairfield Indus., Inc. v. Wireless Seismic, Inc.</i> , No. 4:14-cv-2972, 2015 WL 1034275 (S.D. Tex. Mar. 10, 2015) .....	14
<i>Halliburton Energy Servs., Inc. v. M-I LLC</i> , 514 F.3d 1244 (Fed. Cir. 2008).....	18
<i>Infinity Computer Prods., Inc. v. Oki Data Americas, Inc.</i> , 987 F.3d 1053 (Fed. Cir. 2021).....	6
<i>Intellectual Ventures I LLC v. General Motors Co.</i> , No. 6:21-cv-1088-ADA, Dkt. 83, Dkt. 84 (W.D. Tex. Dec. 1, 2022) .....	7
<i>Interval Licensing LLC v. AOL, Inc.</i> , 766 F.3d 1364 (Fed. Cir. 2014).....	6, 12, 16
<i>Kumar v. Ovonic Battery Co., Inc.</i> , 351 F.3d 1364 (Fed. Cir. 2003).....	26
<i>Mirror Imaging LLC v. Wells Fargo Bank, N.A.</i> , No. 6:21-cv-0465-ADA, Dkt. 28 (W.D. Tex. Feb. 22, 2022).....	13

*Nautilus, Inc. v. Biosig Instruments, Inc.*,  
572 U.S. 898 (2014).....6

*Novo Indus., L.P. v. Micro Molds Corp.*,  
350 F.3d 1348 (Fed. Cir. 2003).....9, 11

*Phillips v. AWH Corp.*,  
415 F.3d 1303 (Fed. Cir. 2005).....25

*Rillito River LLC v. Bamboo Indus. LLC*,  
No. 2:17-cv-00181, 2018 WL 4350095 (E.D. Cal. Sept. 11, 2018).....15

*Standard Oil Co. v. Am. Cyanamid Co.*,  
774 F.2d 448 (Fed. Cir. 1985).....13

*Synchronoss Techs., Inc. v. Dropbox, Inc.*,  
987 F.3d 1358 (Fed. Cir. 2021).....9

*Zadro Prods., Inc. v. SDI Techs., Inc.*,  
No. 17-cv-1406-WCB, 2019 WL 10252726 (D. Del. June 19, 2019).....13

**Other Authorities**

MPEP § 2173.05(e) (9th ed., Nov. 2024) .....20

## I. INTRODUCTION

Intellectual Ventures II LLC (“IV”) asserts twelve patents against Defendant Tesla, Inc. (“Tesla”), six of which include terms that require construction at this stage: U.S. Patent Nos. 6,894,639 (“the ’639 patent”); 7,181,743 (“the ’743 patent”); 7,336,805 (“the ’805 patent”); 8,898,395 (“the ’395 patent”); 9,232,158 (“the ’158 patent”); and 10,136,416 (“the ’416 patent”) (collectively, the “Asserted Patents”). Tesla proposes constructions that remain faithful to the proper scope of the Asserted Patents’ claims. For example, Tesla’s construction of “broadcast information” from claim 1 of the ’416 patent simply applies the plain meaning of the term, which is “information that is received via a broadcast transmission to all UEs within a base station’s coverage area.” That plain meaning is also consistent with the intrinsic record and how relevant extrinsic evidence defines the term.

Where claim language is objectively uncertain, Tesla argues indefiniteness. First, claim 1 of the ’639 patent recites “*said* target feature information,” but there is no other “target feature information” in the claim. Moreover, this limitation could reasonably be interpreted as either “*a* target feature information” or as “said target *specific* feature information,” but the intrinsic record does not specify which one (if either) is correct. Because there are multiple potential interpretations, the term lacks objective certainty and is indefinite.

Second, the “*said* processing” limitation in claim 1 of the ’395 patent also lacks antecedent basis and fails to inform a person of ordinary skill in the art (“POSITA”) with reasonable certainty about the claim scope. Claim 1 recites multiple structures which could perhaps perform “said processing” and it also recites multiple groups of instructions which could perhaps be the subject of “said processing.” Moreover, the timing of “said processing” is objectively uncertain. Because the intrinsic record does not inform a POSITA of which of multiple potential interpretations of “said processing” (if any) is claimed, claim 1 lacks objective certainty and is indefinite.

Third, claim 1 of the '805 patent recites terms of degree whose scope is objectively uncertain in light of the intrinsic evidence—*i.e.*, “may *at least partially describe* a potential destination” and “*potential geometric objects for plausibility* using a matching algorithm so as to identify one or more *plausible objects*.” While terms of degree are not *per se* indefinite, here, the claimed terms lack any objective certainty and both are therefore indefinite.

Thus, Tesla respectfully requests the Court adopt its proposed constructions.

## II. OVERVIEW OF ASSERTED PATENTS<sup>1</sup>

### A. The '639 Patent

The '639 patent, titled “Generalized Hebbian Learning for Principal Component Analysis and Automatic Target Recognition, Systems and Method,” was filed in December 1991 and issued on May 17, 2005. *See* Ex. 1 ('639 patent). The '639 patent is directed to a method of distinguishing targets from background clutter. *Id.* at Abstract. More specifically, the '639 patent describes calculation of data statistics from input data provided by sensors and uses the data statistics to identify and select “feature information” that is used to distinguish targets from background clutter. *Id.*

### B. The '805 Patent

The '805 patent, titled “Docking Assistant,” issued on February 26, 2008. *See* Ex. 2 ('805 patent). The '805 patent purports to describe a method for assisting a driver docking a truck (*e.g.*, in a parking bay or loading platform) using image analysis. *Id.* at Abstract. The vehicle uses a camera (*e.g.*, image sensor 22 on vehicle 20 in Figure 2) to obtain image data. *Id.* at 2:56–57.

---

<sup>1</sup> Tesla provides an overview for only those patents with disputed claim terms (the '639, '805, '395, and '416 patents), but not patents with agreed constructions (the '743 and '158 patents).

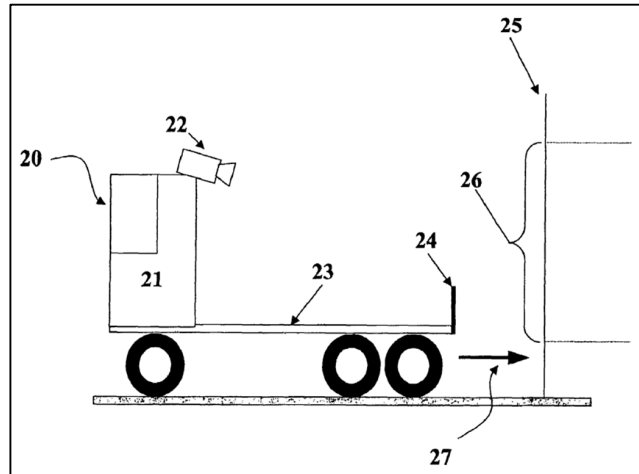

'805 patent at Fig. 2.

The obtained images are analyzed to locate objects, such as a cargo door 26 in Figure 2. *Id.* at 7:13–29. The patented system purports to accomplish this by breaking down the image data into “edge segments” and storing relationships between the edge segments in a “mathematical tree structure.” *Id.* at 3:37–39; 4:43–45. The edge segments “are then analyzed to check for the presence of a geometric object that is similar to a geometric form which, typically, at least partially describes a potential destination.” *Id.* at 3:40–43. The detected geometric objects are then “analyzed for plausibility using a matching algorithm.” *Id.* at 2:41–43, 3:3–8, 3:47–50. Plausible objects undergo additional “acceptance analysis.” *Id.* at 3:41–54. Accepted objects are then used to compute an “optimized travel path” to assist in vehicle guidance. *Id.* at 3:58–64.

### C. The '395 Patent

The '395 patent, titled “Memory Management for Cache Consistency,” issued on November 25, 2014. *See* Ex. 3 ('395 patent). It is a continuation of an application originally filed on April 7, 2005 (now U.S. Patent No. 7,376,798).

The '395 patent purports to describe management of cache memory in a multiprocessor architecture in which groups of instructions are executed atomically by a processor. *Id.* at Abstract;

*id.* at 2:8–9 (Summary of the Invention); *see also id.* at 2:1–7 (alleging prior attempts “are limited to a single memory operation per instruction group” and purporting to give a solution to “overcome this disadvantage”); *id.* at 4:11–12. Each group can include instructions that, when executed by the processor, cause a cache line associated with that processor to be accessed, which in turn causes an indicator associated with that group of instructions in the cache line to be updated to reflect that access. *Id.* at 2:9–15. “The cache line is indicated as having been accessed until execution of the group of instructions is ended.” *Id.* at 2:15–16.

With reference to Figures 1 and 2, processor 10 and external agents 11–13 may each be executing a group of instructions. *Id.* at 4:3–5. An instruction group is handled atomically (*e.g.*, it is treated as a unit) and it may seek access to the cache associated with the processor executing that instruction or to the cache of an external agent. *Id.* at 4:11–15.

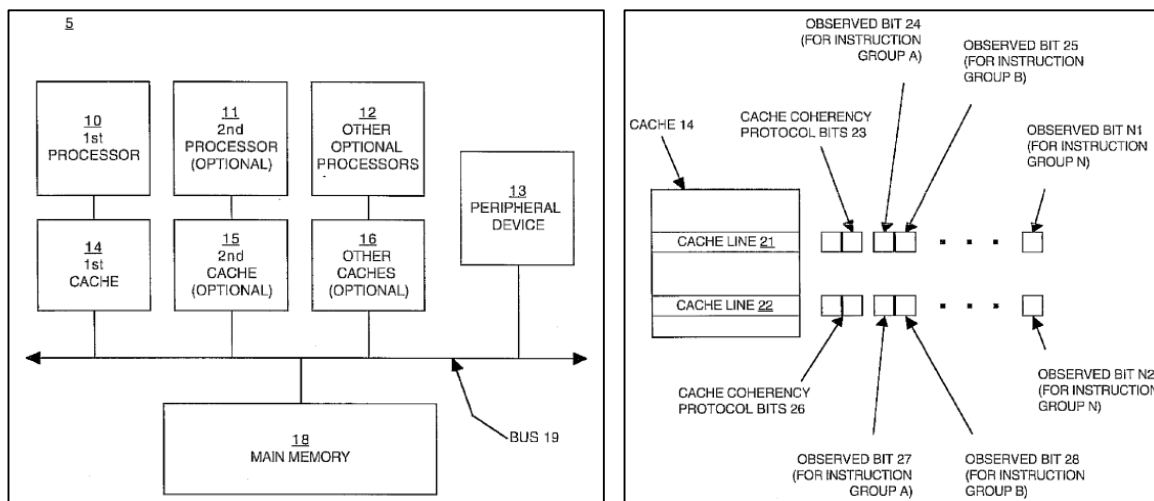

'395 patent at Fig. 1 (left), Fig. 2 (right).

When a given processor, *e.g.*, processor 10, begins to execute a group of instructions, it allocates an observed bit for that group of instructions to each cache line in cache 14. *Id.* at 5:28–32. If cache line 21 is accessed because of an instruction in instruction group A being executed by processor 10, then observed bit 24 is set. *Id.* at 5:32–37. Similarly, if cache line 21 is also

accessed because of an instruction in instruction group B being executed by processor 10, then observed bit 25 is also set.

When execution of an instruction group by a processor, *e.g.*, processor 10, is ended, then the observed bits associated with that instruction group are cleared. For example, when instruction group A “is committed, rolled back, or aborted,” then the observed bit 24 associated with instruction group A in cache line 21 is cleared. *Id.* at 5:41–47. Additionally, if an external agent 11–13 snoops cache line 21 while observed bits 24 and 25 remain set, then instruction group A (corresponding to observed bit 24) and instruction group B (corresponding to observed bit 25) are rolled back, and the observed bits 24 and 25 are cleared. *Id.* at 5:49–61.

#### **D. The ’416 Patent**

The ’416 patent is titled “Communicating on a Shared Channel in a Wireless Network” and issued on November 20, 2018. *See* Ex. 4 (’416 patent). It relates to cellular communications. *Id.* at 1:15–21. Specifically, the ’416 patent purports to reduce wasting cellular resources on unused signaling channels. *Id.* at 3:58–61. It does so by using bits in the Broadcast Channel (“BCH”) to indicate whether a particular timeslot within a frame is needed for signaling, and if not, providing an indication that the channel can be used as a shared channel. *Id.* at 9:38–58.

### **III. LEGAL STANDARDS**

#### **A. Claim Construction**

In view of the Court’s familiarity with claim construction, Tesla will forgo a lengthy recitation of law.<sup>2</sup> Tesla cites particularly relevant authority inline within specific arguments, and otherwise reserves the right to respond to any authority cited in IV’s responsive brief.

---

<sup>2</sup> *See* Judge Albright’s “Standing Order Governing Proceedings (OGP) 4.1–Patent Cases” (Apr. 14, 2022) at Section IX (“The Court has familiarity with the law of claim construction and

## B. Indefiniteness

“A patent is invalid for indefiniteness if its claims, read in light of the patent’s specification and prosecution history, fail to inform, with reasonable certainty, those skilled in the art about the scope of the invention.” *Nautilus, Inc. v. Biosig Instruments, Inc.*, 572 U.S. 898, 898–99 (2014). Claims are indefinite when, for example, “the claim language ‘might mean several different things and no informed and confident choice is available among the contending definitions.’” *Interval Licensing LLC v. AOL, Inc.*, 766 F.3d 1364, 1371 (Fed. Cir. 2014) (quoting *Nautilus*, 572 U.S. at 911 n.8). Seemingly clear terms also may be indefinite based on inconsistent or confusing usage. *See Infinity Computer Prods., Inc. v. Oki Data Americas, Inc.*, 987 F.3d 1053, 1062 (Fed. Cir. 2021) (“We recognize that, in a vacuum, it might seem odd to hold ‘computer’ indefinite. . . . Yet the indefiniteness here does not reside in the term ‘passive link’ or ‘computer’ on its own but rather in the relationship between the two in the context of these claims.”). Further, a claim could be indefinite if a term does not have proper antecedent basis when a POSITA, “faced with the claims and the specification, could not, with reasonable certainty, discern the meaning of the claim term.” *Bushnell Hawthorne, LLC v. Cisco Sys., Inc.*, 813 F. App’x 522, 526–27 (Fed. Cir. 2020).

## IV. LEVEL OF ORDINARY SKILL IN THE ART

Tesla identifies the level of a POSITA for each patent with a disputed claim term:

- **’639 Patent:** A POSITA in December 1991 would have been someone knowledgeable and familiar with the image processing systems pertinent to the ’639 patent. That person would have a bachelor’s degree in computer science, computer engineering, electrical engineering, or equivalent training, and approximately four years of experience working in the field of image processing. Lack of work experience can be remedied by additional education, and vice versa.
- **’805 Patent:** A POSITA in June 2004 would have had a bachelor’s degree in electrical engineering, computer engineering, computer science, or a related

---

encourages the parties to forego lengthy recitations of legal authorities and to instead focus on the substantive issues unique to each case.”).

subject, and four years of work experience in image processing, automated vehicle control/navigation, or a related field. Less experience may be necessary with additional education (e.g., a master’s degree), and likewise, less education may be necessary with additional work experience (e.g., 5–7 years).

- **’395 Patent:** A POSITA in April 2005 would have had a bachelor’s degree in electrical or computer engineering, computer science, or a related subject, and two years of professional experience “in the data processing arts” (Ex. 3 (’395 patent) at 3:4–7) and multiprocessor speculative execution or a related field. Less experience may be necessary with additional education, and likewise, less education may be necessary with additional work experience.
- **’416 Patent:** A POSITA in September 2007 would have had a bachelor’s degree in electrical engineering, computer engineering, or an equivalent, and approximately two years of professional experience relating to wireless communication technology. Lack of professional experience can be remedied by additional education, and vice versa.

## V. AGREED CONSTRUCTIONS

The parties agreed to the following constructions and request the Court adopt these constructions:

### A. ’743 Patent

Term	Agreed Construction
Preamble (claim 10)	Limiting

### B. ’158 Patent

Term	Agreed Construction <sup>3</sup>
“integration time” (claims 1, 8)	“the time the image sensor collects and integrates signal from the scene”
“an image capture device” (claim 1)	“a device including a plurality of sensors, where two or more of the plurality of sensors each capture an overlapping portion of the same scene”

<sup>3</sup> This Court previously construed these two terms from the ’158 Patent. *See Intellectual Ventures I LLC v. General Motors Co.*, No. 6:21-cv-1088-ADA, Dkt. 83 at 2, Dkt. 84 at 46–52 (W.D. Tex. Dec. 1, 2022). The parties agree the Court should adopt its prior constructions.

**VI. DISPUTED TERMS<sup>4</sup>**

**A. “said target feature information” (’639 patent, claim 1) / “said feature information” (’639 patent, claim 7)**

Tesla’s Proposed Construction	IV’s Proposed Construction
Indefinite	Plain and ordinary meaning. Not indefinite.

The term “said target feature information” is indefinite because it lacks antecedent basis and can potentially be interpreted in multiple ways. The claim language and specification provide multiple, equally plausible, ways to address the lack of antecedent basis, and the prosecution history only adds confusion. When Tesla asked IV to identify the antecedent basis, IV refused and instead doubled down on its “plain and ordinary” construction. Ex. 5 (12-18-2024 Email fr. Downing to Ellis re: claim construction).

There can be no dispute the term “said target feature information” lacks antecedent basis. The term refers to “said target feature information” even though the claims do not previously introduce “target feature information.” See Ex. 1 (’639 patent) at claim 1. Thus, the term must be construed to correct the absence of an antecedent basis.

But it is unclear how that can be accomplished because there are at least two ways to remedy the absence of antecedent basis and neither is more likely correct than the other. First, “*said* target feature information” could refer to “*a* target feature information,” which means the word “said” was drafted erroneously. This rewrite would introduce a concept (“target feature information”) to the claim that is not found in any of the other limitations. Second, “*said* target feature information” could refer to “said target *specific* feature information,” which would mean “specific” was omitted erroneously. This second rewrite would make all the “feature information”

---

<sup>4</sup> The disputed terms are addressed in the order specified in Section IX of the Court’s OGP.

the same throughout the claim, but it would change the meaning of the term entirely. Neither option is more likely correct than the other in view of the intrinsic record and, thus, neither is appropriate. *See Novo Indus., L.P. v. Micro Molds Corp.*, 350 F.3d 1348, 1354–58 (Fed. Cir. 2003) (finding claim indefinite and reversing district court’s attempt to correct error in claim because “district court can correct a patent only if (1) the correction is not subject to reasonable debate based on consideration of the claim language and the specification and (2) the prosecution history does not suggest a different interpretation of the claims”); *see also Synchronoss Techs., Inc. v. Dropbox, Inc.*, 987 F.3d 1358, 1366–67 (Fed. Cir. 2021) (affirming indefiniteness finding because patentee’s “proposal would require rewriting the claims, but it is not our function to rewrite claims to preserve their validity” (internal quotations and citations omitted)); *see also Chef Am., Inc. v. Lamb-Weston, Inc.*, 358 F.3d 1371, 1374 (Fed. Cir. 2004) (“Thus, in accord with our settled practice we construe the claim as written, not as the patentees wish they had written it.”).

As to the first option, the claim language and specification support replacing “*said* target feature information” with “*a* target feature information.” This edit would introduce the concept of “target feature information” (whereas the claim previously referred only to “target *specific* feature information”). This edit is consistent with the specification which teaches target “feature information” that may not be target specific. When discussing the background of the invention, the specification discusses “feature information” that varies from target to target (*i.e.*, “target *specific* feature information”) and feature information that may *not* vary target to target (*i.e.*, “target feature information”):

With respect to the complexity of pattern recognition and pattern classification techniques, many of these techniques rely on feature information to differentiate preferred targets from background clutter. Coordination and selection of this feature information is an ongoing problem, as the *desired feature information itself (e.g., contrast-based and texture-based) often varies from target to target (e.g., size, stationary, make-up, composition, orientation)*, target to background (*e.g.*,

location of target), data set to data set (e.g., lighting, time-of-day, ambient temperature, and context of scene, sensor characteristics), and data source to data source (e.g., one-dimensional or multi-dimensional data, such as digitized infrared imagery, digitized TV imagery, digitized Infra-red imagery, speech samples, or radar samples).

Ex. 1 ('639 patent) at 1:29–43 (emphasis added). Similarly, the specification elsewhere refers to both “target *specific* feature information” and more general “feature information” that may not be target specific. Compare Ex. 1 ('639 patent) at 5:50–55 (“The advantages of this method and system and the corresponding hardware and software embodiments are that they generate and select the *target specific feature information* for the classification of preferred targets in the context of particular backgrounds.”), with *id.* at 7:15–20 (“As shown in FIG. 10, the classification system inputs the data in module 2, extracts *feature information* from the inputted data in module 4 and inputs the *feature information* into the classification module 6 . . .”). Accordingly, the specification distinguishes between “target feature information” and “target *specific* feature information,” and the two are not interchangeable.

But that is not the end of the analysis. Other claim language suggests the second option: that “said target feature information” should be edited as “said target *specific* feature information.” Claim 9 recites a similar scope to claim 1, except that claim 9 is an apparatus claim. Indeed, claim 9 includes a set of apparatus that perform functions similar to those in claim 1. Among those, claim 9 includes a generator limitation that performs the same “generating” function as in limitation 1(c), except the generator limitation in claim 9 refers to “said target *specific* feature information” instead of “said target feature information” as in claim 1. See Ex. 1 ('639 patent) at cl. 9 (“(c) a generator to generate said target specific feature information from said data statistics outputted from said calculator”). This suggests that, like claim 9, claim 1 may have been intended to refer to “target *specific* feature information,” but does not.

The prosecution history adds to the confusion. When the application was filed, the “generating” limitation recited “said target *specific* feature information,” but later in prosecution the word “specific” was omitted. Compare Ex. 6 (’639 patent Prosecution History, Dec. 18, 1991 claim submission) at 3, with *id.* (’639 patent Prosecution History, May 28, 2004 claim amendments) at 8. And to the extent IV argues “specific” was inadvertently omitted, the same change was made in claim 18 (unasserted), but not in other claims (*e.g.*, claim 16), so the omission of “specific” across different claims undermines any argument the change was inadvertent. *Id.* at 6, 10.

Therefore, a POSITA would not know if “*said* target feature information” is intended to (i) introduce “target feature information” (another type of information distinct from and broader than the previously introduced “target *specific* feature information”), or (ii) refer back to the previously introduced “target *specific* feature information.” *E.g.*, *24/7 Customer, Inc. v. LivePerson, Inc.*, 235 F. Supp. 3d 1102, 1108 (N.D. Cal. 2016) (finding claim indefinite because “claim 1 recites elements containing different variations of the term ‘data’” so the “Court agrees with LivePerson that it is ambiguous whether these variations of ‘data’ are ‘equivalents, data subsets of each other, or completely different sets of data’”). Even if the inclusion of “said” (or removal of “specific”) was done in error, the Court cannot rewrite the claim because there are now multiple ways to interpret “said target feature information.” *See Novo*, 350 F.3d at 1354–58; *Cellular Commc’ns Equip. LLC v. AT&T, Inc.*, No. 2:15-cv-576, 2016 WL 7364266, at \*10–\*11 (E.D. Tex. Dec. 19, 2016) (finding claim indefinite and refusing to correct antecedent basis issue because correction open to reasonable debate). Thus, these claim terms are indefinite.

**B. “may at least partially describe a potential destination” (’805 patent, claim 1)**

Tesla’s Proposed Construction	IV’s Proposed Construction
Indefinite	Plain and ordinary meaning.

The dispute here turns on whether the specification provides enough clarity to interpret the term of degree: “may at least partially describe a potential destination.” It does not. The specification is silent on how to measure or determine when a potential destination is “at least partially describe[d]” by a geometric object. The specification’s examples either add more subjectivity or ignore the standard altogether.

The term is found in the “analyzing” limitation of claim 1, which requires analyzing the “edge segments” in image data to identify a “geometrical form that may at least partially describe a potential destination”:

[A]nalyzing the plurality of edge segments for the presence of a geometric object associated with a geometrical form that *may at least partially describe a potential destination* so as to identify one or more potential geometric objects; . . . .

The limitation includes several relative terms (“at least,” “partially,” and “potential”), which individually or combined together result in what is indisputably a term of degree.

Although a term of degree is not necessarily indefinite, courts routinely find them indefinite when the specification provides no objective guidance for measuring or otherwise determining the term of degree. “Although absolute or mathematical precision is not required, it is not enough, as some of the language in our prior cases may have suggested, to identify *some standard* for measuring the scope of the phrase.” *Interval Licensing LLC v. AOL, Inc.*, 766 F.3d 1364, 1370–71 (Fed. Cir. 2014) (internal quotations and citations omitted) (emphasis in original). Instead, “[t]he claims, when read in light of the specification and the prosecution history, must provide objective boundaries for those of skill in the art.” *Id.* at 1371; *see also Berkheimer v. HP Inc.*, 881

F.3d 1360, 1364 (Fed. Cir. 2018) (“Our case law is clear that the objective boundaries requirement applies to terms of degree.”). In fact, courts have found “at least partially” to be indefinite when there is no clear objective standard disclosed in the specification. In *Standard Oil*, the Federal Circuit upheld the district court’s ruling that the phrase “at least partially soluble” was indefinite. *Standard Oil Co. v. Am. Cyanamid Co.*, 774 F.2d 448, 451–53 (Fed. Cir. 1985). This Court similarly found “configured to at least partially link two or more interfaces” was indefinite in *Mirror Imaging LLC v. Wells Fargo Bank, N.A.* See Ex. 7 (No. 6:21-cv-0465-ADA, Dkt. 28 at 4 (W.D. Tex. Feb. 22, 2022)).

Indeed, the District of Delaware took issue with “at least in part” for precisely the reasons “at least partially” is indefinite here: because the specification provides no guidance to define the term. In *Zadro Prods., Inc. v. SDI Techs., Inc.*, the court ruled “at least in part generally concentrically aligned” was indefinite because the specification “provides no guidance as to what amount of generally concentric alignment would satisfy the requirement that at least part of the light emitting regions or diodes be generally concentrically aligned with the first reflective mirror plate.” No. 17-cv-1406, 2019 WL 10252726, at \*1–\*3 (D. Del. June 19, 2019). The court noted “the addition of the phrase ‘at least in part’ must be interpreted as intended to broaden the reach the claim language beyond what it would have been had only the phrase ‘generally concentrically aligned’ been used.” *Id.* at \*3. But the claim was indefinite because “there is no guidance in the claim language or the specification as to the limits on how broadly that language in the claims should be read.” *Id.*

So too here. The specification provides no objective, reasonably certain way to measure when a “geometric object” “may at least partially describe a potential destination.” This phrase is never described with any detail or used in a relevant example. The specification discusses the

“analyzing” limitation, but that discussion does not provide an objective standard for determining whether something “at least partially describe[s] a potential destination.” Rather, the discussion uses other terms of degree, such as “substantially,” “roughly,” and “approximately,” to describe the claimed “analy[sis]” (in this example, analyzing whether a docking station “substantially corresponds” to a rectangle):

In a subsequent step, these edge segments are then analyzed to check for the presence of a geometric object that *is similar to* a geometric form which, *typically, at least partially* describes a potential destination. If the typical destination is a docking station for trucks at a warehouse, for example, then the *typical geometric form substantially corresponds to a rectangle having roughly identical side lengths of approximately 2.5 m*. Within the framework of the inventive method, the detected geometric objects that correspond to the typical geometric form are then analyzed for plausibility using a matching algorithm, these objects, which are classified as plausible, undergoing an additional acceptance analysis . . . .

Ex. 2 ('805 patent) at 3:39–52 (emphasis added). Simply substituting different relative words (“similar to,” “substantially,” or “roughly”) for the claimed term of degree (“at least partially”) is not sufficient. *See, e.g., Fairfield Indus., Inc. v. Wireless Seismic, Inc.*, No. 4:14-cv-2972, 2015 WL 1034275, at \*14–\*16 (S.D. Tex. Mar. 10, 2015) (finding indefiniteness and noting patentee’s original proposed construction “merely substituted one ambiguous term, ‘to the extent reasonably practical,’ for another ‘substantially prevent’”).

The specification provides an example of a determination of a potential destination, but the example further confuses the issue. Figure 3 illustrates a loading platform 35 for a truck docking at a cargo door 32 of a warehouse:

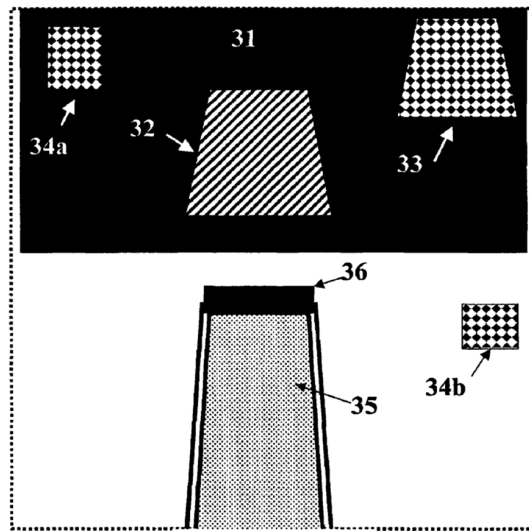

The specification glosses over the technique for determining that geometric objects in this image “may at least partially describe[s] a potential destination,” instead saying this step is “assumed”:

Due to the elevated position of image sensor (22), a cargo door (26, 32) having a rectangular geometry is produced as a trapezoidal image in the image data. *It is assumed exemplarily that, after processing of the image data in image-processing unit (11) and of the tree traversal algorithm in unit (12), objects 32, 33, 34 a and 34 b are identified as geometric objects typically corresponding to a potential destination.* It is assumed that object 32 corresponds to the image of cargo door (26) sought as a destination.

Ex. 2 ('805 patent) at 7:22–31 (emphasis added). It cannot simply be the case that the image is analyzed for real objects, because at least items 34a and 34b (which the specification says is assumed to “at least partially describe a potential destination”) are not images of real objects. *Id.* at 7:33–37. There is no explanation as to what criteria the specification uses to make its assumptions. Thus, the specification falls short of providing an objective standard for measuring when a geometric object “at least partially describe[s] a potential destination.”

Because the specification does not provide an objective basis for a POSITA to determine what degree of “describing” would satisfy the requirement of “at least partially describ[ing] a potential destination,” claim 1 is indefinite. *See, e.g., Rillito River LLC v. Bamboo Indus. LLC,*

No. 2:17-cv-00181, 2018 WL 4350095, at \*9–\*11 (E.D. Cal. Sept. 11, 2018) (ruling “partially surround” was indefinite because “patent offers no details as to the degree of ‘partially surround’” and “claim term is insufficiently defined to offer one ordinarily skilled in the art a means by which to calculate ‘partially surround’”).

**C. “potential geometric objects for plausibility using a matching algorithm so as to identify one or more plausible objects” (’805 patent, claim 1)**

Tesla’s Proposed Construction	IV’s Proposed Construction
Indefinite	Plain and ordinary meaning.

Like the other term from the ’805 patent, the dispute here turns on whether the specification provides enough clarity to determine or measure the term of degree: “plausibility” and “plausible objects.” Again, it does not. The relevant language requires “plausibility using a matching algorithm . . . to identify one or more plausible objects.” The specification discusses “matching algorithms” but fails to explain when the outcome of the matching algorithm is “plausible.” Thus, claim 1 is indefinite.

The relevant limitation from claim 1 requires “analyzing the one or more potential geometric objects for plausibility using a matching algorithm so as to identify one or more plausible objects,” thereby including terms of degree (“plausibility” and “plausible”). As explained above, the law requires the specification to provide a standard for measuring terms of degree. *See Interval Licensing*, 766 F.3d at 1370–71. Here, though, the specification is silent about the basis to determine when a “potential geometric object” is “plausible.” For example, the specification is unclear about what constitutes a sufficient match from the “matching algorithm” for the “potential geometric objects” to be “plausible.”

The matching algorithm referenced in the specification is silent on when such matching algorithm produces a “plausible object.” The specification explains the “IPC algorithm” described

in a paper by Paul Besl is “particularly advantageously suited” for the claimed “matching algorithm.” Ex. 2 (’805 patent) at 5:25–29. But the Besl paper discusses how to process collected data so the data can be analyzed for a match—it never explains when the outcome of the matching algorithm is “plausible” or how to determine “plausibility.” *See generally* Ex. 8 (Besl Paper, TESLAIV000023924). Beside the IPC algorithm, the specification only mentions “matching algorithm” at a high level without ever providing details for when it produces “plausible objects.” *See, e.g.*, Ex. 2 (’805 patent) at 3:3–8 (“In addition, the image-processing unit includes a comparator unit (13) for analyzing the detected geometric objects which correspond to the typical geometric form, to **check for plausibility using a matching algorithm** for making a comparison with object patterns stored in a memory unit (17).” (emphasis added)).

The specification also refers to an “acceptance analysis,” but that discussion similarly fails to provide objective criteria for determining what is “plausible.” For example, the specification discusses rejecting potential destinations based on either shape or position but does not explain how to determine whether a particular shape or position should result in rejecting a potential destination:

In one especially advantageous type of acceptance analysis, in those cases in which the surrounding field is recorded by the sensor from an elevated position, those objects which **do not exhibit any distorted images, as compared to their usual geometric shapes**, are rejected as potential destinations. For example, the distortion of rectangular or square geometric shapes of potential destinations is manifested as a trapezoid in an image formation. In another effective type of acceptance analysis, based on knowledge of the customary position of destinations, **objects not corresponding to these specifications in the image data** are rejected. For example, if an object is included in the image data whose position relative to the imaging sensor is known, then, on the basis of its image formation in the image data, an artificial horizon may be generated, on whose basis the relative position of the recognized objects is ascertained. In this manner, **objects, whose position deviates from the usual position of the destination**, are excluded from the further processing.

Ex. 2 ('805 patent) at 5:64–6:15 (emphasis added). The disclosure of rejecting a destination because the objects “do not exhibit any distorted images,” the objects do “not correspond[] to the specification,” or the position “deviates” from the usual position does not (a) provide a standard to determine distortion, correspondence, or deviation; or (b) any guidance on how much distortion, correspondence, or deviation is required to reject a destination such that the object is not “plausible.” This example does not add clarity to the term at issue.

The specification mentions “plausible objects” only twice but neither passage helps. The first instance parrots the claim language. Ex. 2 ('805 patent) at 2:43–47. The second instance fares no better: “By already observing such elementary rules when processing the hierarchical tree structure, the subsequent outlay for processing may be limited already at this stage of the inventive method to relatively few *plausible objects which are actually similar to a potential destination.*” Ex. 2 ('805 patent) at 5:8–13. Adding terms of degree, like “actually similar,” falls short of providing an objective standard for identifying “plausible objects.”

Because the specification fails to provide an objective standard to determine when the matching algorithm produces “plausible objects,” claim 1 of the '805 patent is indefinite.

**D. “said processing” ('395 patent, claim 1)**

Tesla’s Proposed Construction	IV’s Proposed Construction
Indefinite	Plain and ordinary meaning. Not indefinite.

The limitation “said processing” lacks antecedent basis and thus requires modification, but there is no clear correction for that lack of antecedent basis. Thus, the term is indefinite. *See Halliburton Energy Servs., Inc. v. M-I LLC*, 514 F.3d 1244, 1249 (Fed. Cir. 2008) (claim is “indefinite if a term does not have proper antecedent basis where such basis is not otherwise present by implication or the meaning is not reasonably ascertainable”); *Bushnell Hawthorne*, 813

F. App’x at 526–27 (claim is indefinite when scope could not be reasonably ascertained given lack of antecedent basis); *In re Downing*, 745 F. App’x 988, 996 (Fed. Cir. 2018) (holding “the lack of an antecedent basis does not render a claim indefinite” only “as long as the claim apprises [a POSITA] of its scope, and therefore, serves the notice function required by § 112 ¶ 2”); *eCardless Bancorp, Ltd. v. PayPal Inc.*, No. 24-cv-01054, 2024 WL 4804975, at \*12 (N.D. Cal. Nov. 14, 2024) (“Antecedent basis is necessary so [POSITA] can ascertain the scope of a patent and its claimed inventions with ‘reasonable certainty.’” (citing *Nautilus*, 572 U.S. at 909)).

The claim language causes further confusion as it introduces: (1) different groups of instructions that could perhaps be the subject of “said processing”; (2) multiple structures that could perhaps perform “said processing”; and (3) different times at which “said processing” could occur. Specifically, “said processing” *might* refer to an action on “an instruction in a first group of instructions,” “an instruction in a second group of instructions,” or an instruction in “a third group of instructions.” *See* Ex. 9 (Herlihy Decl.) ¶ 43. Further, “said processing” *might* refer to an action taken by the claimed “processor” or by the claimed “agent other than said processor.” *See* Ex. 9 (Herlihy Decl.) ¶ 43. Finally, there is added objective uncertainty as to the timing of “said processing,” which a POSITA would recognize *might* be performed immediately or, alternatively, the cache line *might* be marked for a later rollback. *Compare* Ex. 3 (’395 patent) at 5:49–56 (describing “one embodiment” in which “the instruction groups associated with the observed bits that are set are forced to roll back and then reissue”), *with id.* at 8:54–62 (describing other “embodiments in accordance with the present invention” where “a protocol . . . causes all active instruction groups to roll back and reissue **after the cache line state transition**” (emphasis added)); *see also* Ex. 9 (Herlihy Decl.) ¶ 47 (explaining a POSITA would understand, *e.g.*, that the rollback *might* suspended for a brief duration to give a conflicting instruction group a chance to

complete). Indeed, the timing uncertainty further compounds the uncertainty over which structure performs “said processing.” Ex. 9 (Herlihy Decl.) ¶ 47.

As seen in claim 1 (below), the word “processing” appears twice. The first instance recites “said processing” as part of a wherein clause (limitation 1[c][2]) following the “executing a third group of instructions” step (shown in **green**),<sup>5</sup> and the second instance is in a “processing” method step (limitation 1[d]) for “said first group and said second group of instructions” (shown in **blue**):

1[pre] A method of managing memory in a computer system, said method comprising:

1[a] setting a first bit of an indicator associated with a cache line in a cache memory if said cache line has been accessed in response to a processor executing an instruction in a first group of instructions;

1[b] setting a second bit of said indicator while said first bit remains set if said cache line has also been accessed in response to said processor executing an instruction in a second group of instructions;

1[c][1] executing a third group of instructions that causes said cache line to be accessed, wherein said third group of instructions is executed by an agent other than said processor,

1[c][2] wherein **said processing** comprises rolling back said first group of instructions provided said first bit is set and rolling back said second group of instructions provided said second bit is set before allowing an instruction in said third group to access said cache line, and otherwise granting said access; and

1[d] **processing** said first group and said second group of instructions according to a value of said indicator.

The first point of objective uncertainty is what is processed by “said processing.” The recitation of “said processing” in limitation 1[c][2], which is within the method step for executing the **third** group of instructions (limitation 1[c][1]), suggests the action is being taken on the **third**

---

<sup>5</sup> The use of the article “said” rather than “a” is significant. The Manual of Patent Examining Procedure dictates how the articles “a” and “the” / “said” are used in patent claims. Specifically, the first time a word or phrase is mentioned, the article “a” should be used, while thereafter the article “the” or “said” should be used to refer back to the antecedent basis. MPEP § 2173.05(e) (9th ed., Nov. 2024).

group of instructions. *See* Ex. 9 (Herlihy Decl.) ¶ 45. However, the remainder of the limitation indicates otherwise as it recites “rolling back said *first* group of instructions . . . and rolling back said *second* group of instructions.” The specification does not help to resolve this uncertainty because instructions from each of the first, the second, and the third groups of instructions are all potentially being processed in the computer system. *E.g.*, Ex. 3 (’395 patent) at 6:62–65. Accordingly, it is not reasonably ascertainable to a POSITA from the full specification which group of instructions is subject to “said processing” in claim 1. *See* Ex. 9 (Herlihy Decl.) ¶ 45.

Further compounding this objective uncertainty, the claim language is also unclear as to which structure performs “said processing,” as the claim recites both “a processor” and “an agent other than said processor” before reciting the “said processing” limitation. Indeed, “said processing” is recited in limitation 1[c][2], which is a sub-step of the third method step. The claim requires the third method step (limitation 1[c][1]) is performed “by an agent *other than said processor*.” Ex. 3 (’395 patent) at cl. 1 (emphasis added). A POSITA would therefore understand that “said processing” in the sub-step of the third method step is likewise performed by that same “agent *other than said processor*.” *Id.*; Ex. 9 (Herlihy Decl.) ¶ 44. However, the remainder of the limitation concerns the first and the second groups of instructions, which are executed by *the processor* in the earlier-recited method steps (limitations 1[a] and 1[b]). *See* Ex. 3 (’395 patent) at cl. 1; Ex. 9 (Herlihy Decl.) ¶ 44. Furthermore, the specification is silent as to which structure performs “said processing” that “comprises rolling back said first group of instructions . . . and rolling back said second group of instructions.” *See, e.g.*, Ex. 3 (’395 patent) at 5:54–56 (describing the result—“then the instruction groups associated with the observed bits that are set are forced to roll back”—without identifying the responsible structure), *id.* at 5:58–61 (same), *id.* at 6:6–11 (same), *id.* at 7:59–62 (same, with reference to step 43 in Figure 4), *id.* at 6:65–7:3

(describing “some or all of the processes . . . are executed by one or more of the agents **10-13**”); *see also id.* at 6:12–16 (describing *when*, but not *how*, rollbacks could occur), *id.* at 6:24–29 (same). Accordingly, it is not reasonably ascertainable to a POSITA whether “said processing” in claim 1 is performed by the recited “processor” or the recited “agent other than said processor.” *See* Ex. 9 (Herlihy Decl.) ¶ 44.

Claim 2 also adds objective uncertainty. The language of dependent claim 2 refers to “said processing,” but it does not resolve the uncertainties in independent claim 1:

2. The method of claim 1 wherein *said processing* further comprises:

determining a state of said cache line, wherein said state is specified according to a cache coherency protocol comprising at least a modified state, a shared state, and an invalid state; and

rolling back said first group of instructions provided said first bit is set and rolling back said second group of instructions provided said second bit is set, and then granting said access provided said cache line is in other than said shared state, and otherwise granting said access only when said cache line is in said shared state.

Rather, it remains unclear which of the two recited structures performs “said processing,” and which of the three recited groups of instructions is the subject of “said processing,” making this claim indefinite. Specifically, the state of the cache line can be determined when processing any of the first, the second, or the third groups of instructions by, *e.g.*, checking cache coherency protocol bits. *See* Ex. 9 (Herlihy Decl.) ¶ 46; *see also* Ex. 3 (’395 patent) at 6:20–24 (“In one embodiment, . . . the cache coherency protocol bits **23** are also checked to determine the state (*e.g.*, the MESI state) of cache line **21**.”).

Finally, the prosecution history does not provide reasonable clarity. A “processing” step was added by amendment as the *second limitation* of dependent claim 34:

34. (Currently Amended) The method of Claim 33 further comprising:  
executing a third group of instructions that causes said cache line to be accessed;  
using a value of said indicator to determine whether said cache line has been read and generating a result thereof; and  
processing handling said first group and said second group of instructions according to a value of said indicator said result.

Ex. 10 ('395 patent Prosecution History, June 17, 2010 Response to Non-Final Rejection) at 3 (highlight added). Claim 35 (which depended from claim 34) was also amended to recite a “said processing” limitation, which then derived its antecedent basis from amended claim 34:

35. (Currently Amended) The method of Claim 34 wherein said third group of instructions is executed by an agent other than said processor, wherein said processing handling comprises rolling back said first group of instructions provided said first bit is set and rolling back said second group of instructions provided said second bit is set before allowing an instruction in said third group to access said cache line granting said access provided said indicator indicates said cache line has been read, and otherwise granting said access without rolling back said first group and said second group of instructions.

*Id.* at 4 (highlight added). However, in a later amendment, the text of amended claim 35 was added to the *first limitation* of amended claim 34, and that text was then added to independent claim 33 thereby introducing an antecedent basis issue by changing the order of limitations:

executing a third group of instructions that causes said cache line to be accessed, wherein said third group of instructions is executed by an agent other than said processor, wherein said processing comprises rolling back said first group of instructions provided said first bit is set and rolling back said second group of instructions provided said second bit is set before allowing an instruction in said third group to access said cache line, and otherwise granting said access;  
and  
processing said first group and said second group of instructions according to a value of said indicator.

Ex. 11 ('395 patent Prosecution History, June 30, 2014 Response to Decision on Appeal) at 2 (excerpt of amended claim 33, now claim 1) (highlights added). Further, by rewriting “said processing” to now be part of the step of “executing a third group of instructions . . . by an agent other than said processor,” the Applicant compounded the objective uncertainties discussed above.

When Tesla explained the issue and asked IV to clarify the meaning of “*said* processing,” IV refused and instead doubled down on its “plain and ordinary” construction. *E.g.*, Ex. 5 (12-18-2024 Email fr. Downing to Ellis re: claim construction).

The term “said processing” is indefinite because: (1) it lacks an antecedent basis, (2) the specification provides multiple ways to interpret this claim language, and (3) a POSITA cannot reasonably resolve the objective uncertainty.

**E. “broadcast information” ('416 patent, claim 1)**

Tesla’s Proposed Construction	IV’s Proposed Construction
Plain meaning, which is “information that is received via a broadcast transmission to all UEs within a base station’s coverage area.”	Plain and ordinary meaning.

Tesla’s proposed construction has three parts: (1) the receipt of information (“information that is received”); (2) through a broadcast (“via a broadcast transmission”); (3) by devices within

a coverage area (“to all UEs within a base station’s coverage area”). Each of these parts is within the plain meaning of the phrase—Tesla construes the term only to assist the factfinder. IV disputes Tesla’s construction under the guise of “plain and ordinary meaning” but has never explained the nature of its dispute.

Tesla’s proposed construction is consistent with the claim language. The full limitation refers to “receiv[ing]” information through a “broadcast”: “a receiver, the receiver configured to *receive broadcast information* including a plurality of bits, wherein each of the plurality of bits indicates a respective time interval that physical shared channel resources are utilized to signal channels.” Ex. 4 (’416 patent) at cl. 1 (emphasis added). Although the claim does not explicitly state the information is received by “all UEs within a base station’s coverage area,” that is the plain meaning of “broadcast.” As an example, a common usage of “broadcast” is a radio broadcast or television broadcast, which is a communication that is not directed or otherwise addressed to a *particular* user or device, but rather received by all radio or television consumers within an applicable coverage area.

This interpretation is also consistent with the intrinsic record. For example, the ’416 patent explains that “broadcast information” is information “relevant to that cell, such as the network identity[.]” *Id.* at 3:20–23. The ’416 patent distinguishes “broadcast” messages sent to “*all* UEs in a cell” from communications “targeted” to particular UEs. *Id.* at 11:16–26 (“[T]he indicator bits may be either *broadcast to all* UEs in a cell, *or transmitted to a targeted group* of one or more UEs in a cell.”) (emphasis added).

Other aspects of the intrinsic record similarly require Tesla’s interpretation. U.S. Patent Nos. 6,111,865 (“the ’865 patent”), 8,493,909 (“the ’909 patent”), and 8,446,849 (“the ’849 patent”) were all considered during prosecution and are thus part of the intrinsic record. *Phillips*

*v. AWH Corp.*, 415 F.3d 1303, 1317 (Fed. Cir. 2005) (explaining intrinsic record “includes the prior art cited during the examination of the patent.”); *see also Kumar v. Ovonic Battery Co., Inc.*, 351 F.3d 1364, 1368 (Fed. Cir. 2003) (adopting definition provided by prior art in intrinsic record); *Arthur A. Collins, Inc. v. N. Telecom Ltd.*, 216 F.3d 1042, 1044–45 (Fed. Cir. 2000) (construing term based on its usage in prior art cited in patent). Each uses “broadcast” to refer to communications to all receivers within a range. For example, in the ’909 patent, a “broadcast” is a message sent “all the UEs” in a cell. Ex. 12 (’909 patent) at 4:37–41 (“The MAC-b (MAC-broadcast) entity handles only the radio-cell-relevant system information which is broadcast to all the UEs in the relevant radio cell by mapping the logical broadcast control channel BCCH to the transport broadcast channel BCH.”). Similarly, when referring to communications with other terminals, the ’865 patent uses “broadcast” to refer to communication sent to “all” terminals. Ex. 13 (’865 patent) at 5:51–54 (“The multi-bit quick page message could also be used to indicate that the full paging channel should be performed for a longer duration so that system parameter changes can be broadcast to all the wireless terminals 10.”). The ’849 patent includes similar usage. Ex. 14 (’849 patent) at 9:48–55 (“Transport Channels comprises a Broadcast Channel (BCH), Downlink Shared Channel (DL-SCH) and a Paging Channel (PCH), the PCH for support, of UE power saving (DRX cycle is indicated by the network to the UE), broadcasted over entire cell . . .”).

Tesla’s interpretation of the plain and ordinary meaning is also corroborated by the relevant extrinsic evidence. The ’416 patent relies on teachings from cellular standards (referred to as 3GPP standards). *E.g.*, Ex. 4 (’416 patent) at page 2 (citing 3GPP standards as prior art), 1:25–33 (citing 3GPP standards as “Background”), 9:33–38 (referring to the patented system as being “described in a context” of channels “defined in” various 3GPP standards). 3GPP standards

(including, for example, 3GPP TS 25.221, which is cited in the '416 patent at 2:2–3) rely on a standardized vocabulary promulgated by the 3GPP for terms such as “broadcast.” *See, e.g.*, Ex. 15 (3GPP TR 21.905 v10.3.0, “3rd Generation Partnership Project; Technical Specification Group Services and Systems Aspects; Vocabulary for 3PP Specification (Release 10)”) (“3GPP Vocabulary”). And, like Tesla’s proposed interpretation, the 3GPP Vocabulary defines “broadcast” as “denot[ing] unidirectional *distribution to all users.*” *Id.* at TESLAIV000022278 (emphasis added).

Thus, Tesla’s interpretation of “broadcast” is consistent with the intrinsic and extrinsic evidence and should be adopted.

## **VII. CONCLUSION**

For these reasons, the Court should adopt (i) the parties’ agreed constructions and (ii) Tesla’s proposed constructions for the disputed terms in the Asserted Patents.

Dated: January 9, 2025

Respectfully Submitted,

FISH & RICHARDSON P.C.

By: /s/ Daniel R. Gopenko

Aamir A. Kazi (admitted to W.D. Tex.)  
kazi@fr.com  
1180 Peachtree Street, 21st Floor  
Atlanta, GA 30309  
(404) 892-5005

Daniel R. Gopenko (admitted to W.D. Tex.)  
gopenko@fr.com  
1000 Maine Ave SW, Suite 1000  
Washington, DC 20024  
(202) 783-5070

David M. Hoffman (TX Bar No. 24046084)  
hoffman@fr.com  
111 Congress Avenue, Suite 2000  
Austin, TX 78701  
(512) 472-5070

Matt Colvin (TX Bar No. 24087331)  
colvin@fr.com  
Michael Ellis (TX Bar No. 24102726)  
ellis@fr.com  
1717 Main Street, Suite 5000  
Dallas, TX 75201  
(214) 747-5070

Kathryn Quisenberry (TX Bar No. 24105639)  
quisenberry@fr.com  
909 Fannin Street, Suite 2100  
Houston, TX 77010  
(713) 654-5300

TESLA, INC.

Alex Hanna (admitted to W.D. Tex.)  
CA Reg. In-House Counsel  
alehanna@tesla.com  
3000 Hanover Street  
Palo Alto, CA 94304  
(650) 586-2409

**COUNSEL FOR DEFENDANT,  
TESLA, INC.**

**CERTIFICATE OF SERVICE**

The undersigned hereby certifies that the foregoing document was filed electronically in compliance with Local Rule CV-5(a) on January 9, 2025, and was served via CM/ECF on all counsel of record.

*/s/ Daniel R. Gopenko*

\_\_\_\_\_  
Daniel R. Gopenko