

3GPP Long Term Evolution: Architecture, Protocols and Interfaces

Aderemi A. Atayero, Matthew K. Luka, Martha K. Orya, Juliet O. Iruemi
Department of Electrical & Information Engineering
Covenant University, Nigeria

ABSTRACT

The evolution of wireless networks is a continuous phenomenon. Some key trends in this changing process include: reduced latency, increased performance with substantial reduction in costs, and seamless mobility. Long Term Evolution (LTE) is based on an evolved architecture that makes it a candidate of choice for next generation wireless mobile networks. This paper provides an overview of both the core and access networks of LTE. Functional details of the associated protocols and interfaces are also presented.

Keywords: 3GPP, Evolved Packet System, Interfaces, LTE, Protocols

I. INTRODUCTION

Evolution (LTE) started with the third Generation Partnership Project (3GPP) release 8 and continued in release 10 with the objective of meeting the increasing performance requirements of mobile broadband [1]. Some key features of release 8 include: high spectral efficiency, very low latency, support of variable bandwidth, simple protocol architecture, and support for Self-Organizing Network (SON) operation. Release 10, otherwise known as *LTE Advanced* is a fourth generation (4G) specification that provides enhanced peak data rates to support advanced services and applications (100 Mb/s for high mobility and 1 Gb/s for low mobility).

The LTE protocol architecture is made up of two planes: the user plane, which provides functions such as formatting user traffic between User Equipment (UE) and the Evolved Universal Terrestrial Radio Access.

Network (E-UTRAN); and the control plane, which support functions used for control purposes such as network authentication. The components of the E-UTRAN - the evolved Node Bs (eNBs) are interconnected by the X2 interface. The eNBs are connected to the EPC via the S1 interface [2]. The S1-MME interface links the eNBs to the Mobility Management Entity (MME) and the S1-U interface links the eNBs to the serving gateway. Other interfaces for interconnecting the elements of the core network and other 3GPP and non-3GPP networks exist.

The remainder of this paper is structured as follows: section II, which is divided into two sub-sections, provides a thorough overview of the architectural layout of functional network nodes. Section III offers a comprehensive disquisition on the network interfaces, and it is followed by a detailed overview of the associated protocol architectural layout in section IV. The paper ends in section V with conclusions.

II. SYSTEM ARCHITECTURE

The LTE network is based on Evolved Packet System (EPS). The EPS is comprised of the radio access network known as E-UTRAN, and an IP core network: the Evolved Packet Core (EPC). The EPS integrates all applications over a simplified and common architecture to provide subscribers with operator's services such as Voice over Internet Protocol (VoIP) and Internet browsing. Using a fully shared radio resource allocation scheme maximizes the use of radio resources. EPS supports quality of service (QoS) by setting up EPS bearers for each application. The EPS bearers are associated with a Quality Class Identifier (QCI), and an Allocation and Retention Priority (ARP). The QCI specifies service priority, packet delay budget and acceptable packet loss rate. The bearer's ARP is used to decide whether or not the requested bearer should be established in case of radio congestion. As illustrated in Fig. 1, EPS supports interworking with other 3GPP and non-3GPP wireless technologies. The functional components of the EPC and E-UTRAN are illustrated in Fig. 1. The E-UTRAN

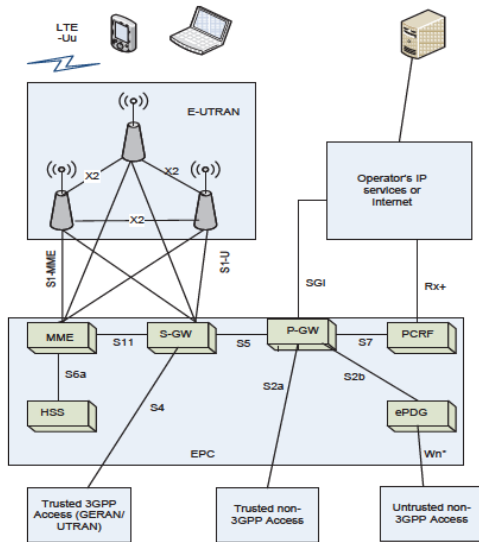

Fig. 1: EPS Network Elements



handles tasks that are related to radio functionality of the EPS such as coding, multi-antenna techniques, radio-resource handling, retransmissions handling and scheduling. The EPC handles non-radio related tasks and supports heterogeneous access networks such as WiFi, WiMax and even wired technologies.

A. The Core Network

The EPC is composed of several functional entities that are responsible for the overall control of the UE (User Equipment) and bearers establishment. The MME is the principal control node for the radio access network. It handles functions related to bearer management, which involves signaling procedures used to set up packet data context and negotiate associated parameters like the QoS. MME also handles security procedures, which involve authenticating the user (Access Stratum security) as well as generation and integration of ciphering and integrity protection algorithms (Non-Access Stratum security). Another major function of the MME is UE location management – it tracks and maintains the current location of UE. Other functionalities and features of the MME include: facilitating self-optimizing network (SON) capabilities to the E-UTRAN and EPC, high availability to help ensure customer satisfaction, congestion management, load sharing, MME pooling, intra-MME handoffs *et cetera*.

The Serving Gateway (S-GW) is the user plane node that connects the E-UTRAN to the EPC. It supports seamless intra E-UTRAN mobility as well as well as mobility with other 3GPP technologies such 2G/GSM and 3G/UMTS. It also retains information about EPS bearers when the UE is in the idle state. Additionally, it performs some administrative functions involving lawful interception and accounting of user data.

The Packet Data Network Gateway (P-GW) connects UE to external Packet Data Networks (PDNs) and acts as the UE default router to the Internet. The P-GW is also responsible for assigning IP addresses to mobile devices. It also uses the Traffic Flow Templates (TFTs) to filter downlink user packets into different QoS based bearers. P-GW acts as mobile home agent (HA) to support seamless mobility of the UE between LTE and trusted non-3GPP networks such CDMA2000 and WiMax. Other functions of the P-GW include: policy enforcement (applies to operators-defined rules for resource allocation and usage), charging support and lawful interception of user traffic.

The PCRF (Policy Control and Charging Rules Function) is a software component that efficiently accesses subscriber database and other specialized functions for policy control decision making. It also controls the flow-based charging functionality in the Policy Control Enforcement Function (PCEF), which resides in the P-GW.

The HSS (Home Subscriber Server) functions as the database for storing subscription data such as QoS profile, and information about the external PDNs to which

the subscriber can access, and the MME to which the UE is currently attached. Additionally, the HSS may house the authentication centre (AUC), which generates the vectors for authentication and security keys.

The ePDG (evolved Packet Data Gateway) is responsible for interworking between the EPC and untrusted non-3GPP networks that require secure access, such as a WiFi, LTE metro, and femtocell access networks. It performs important security functionality, tunnel authentication and authorization, and IPsec encapsulation and de-capsulation of packets. Lawful interception at the ePDG is very important as not trusted accesses are involved.

B. Radio Access Network

LTE radio access network consists of only evolved Node Bs (eNB) and no centralized controller (for normal user traffic). Due to the absence of a network controller, it is said to have a flat architecture. This structure reduces system complexity and cost and allows better performance over the radio interface. From a functional perspective, the eNB is responsible for:

1. IP header compression and encryption of the user data stream.
2. Radio resource control which relates to the allocation, modification and release of resources for transmission over the radio interface between the UE and the eNB.
3. Selection of the MME during a call.
4. Transfer of paging and broadcast messages to the UEs and
5. Intra-eNB mobility control.

The eNBs are interconnected by the X2 interface. The S1-MME interface connects the eNBs to the key control plane of the core network-the MME, while the S1-U interface connects the eNBs and the S-GW.

III. LTE INTERFACES

The LTE interfaces can be grouped into five categories, namely: Air interface, E-UTRAN interfaces, Core network interfaces, Mobility and interworking interfaces, and service interfaces.

A. Air Interface

The LTE-Uu provides the reference point for the radio interface between the UE and eNB. It encompasses the control plane and user plane. The signaling connection across the LTE-Uu interface is the Radio Resource Control (RRC) signaling connection, which is stacked into the Packet Data Convergence Protocol (PDCP), Radio Link Control (RLC) and Media Access Control (MAC) layers. The PDCP, RLC, and MAC layers constitute the user plane protocols for the air interface (see Fig. 3).



B. E-UTRAN Interfaces

The X2 interface is the interface between eNBs. Its functionalities are split into control plane and user planes. The X2 user plane interface provides buffered packet data forwarding when the UE moves from one eNB to another. The X2 control plane interface is a reliable signaling interface, which supports a number of functions and procedures between eNBs. These features involve load-balancing management, handover related information.

The S1 interface connects the E-UTRAN to the EPC. The S1-MME connects eNB to the control segment of the EPC – the MME, while the S1-U connects the eNB to the user plane segment via the S-GW. The S1-MME interface provides a reliable and guaranteed data delivery by using SCTP over IP. It is responsible for procedures like EPS bearer setup/release, handover signaling, paging procedure and NAS transport procedure. On the other hand, the S1-U takes care of delivering user data between the eNB and S-GW. It consists of GTP-U over UDP/IP and provides non-guaranteed information delivery.

C. EPC Nodal Interfaces

The interfaces interconnecting the functional elements of the core network include:

1. S2b Interface: provides the user plane with related control and mobility support between the ePDG and P-GW. It is based on the proxy Mobile IP.
2. S5 Interface: this interface provides user plane tunneling and tunnel management between S-GW and P-GW. It is used for S-GW relocation due to UE mobility and if the S-GW needs to connect to a non-collocated P-GW for the required PDN connectivity. Two variants of this interface are being standardized depending on the protocol used, namely, GTP and the IETF based Proxy Mobile IP solution [4].
3. S6a Interface: It enables transfer of subscription and authentication data for authenticating/authorizing user access to the evolved system (AAA interface) between MME and HSS.
4. S7 interface: It provides transfer of (QoS) policy and charging rules from Policy and Charging Rules Function (PCRF) to Policy and Charging Enforcement Function (PCEF) in the P-GW. This interface is based on the legacy Gx interface.
5. S11 interface: This is the reference point between MME and S-GW

D. Network Mobility / Internetworking Interfaces

These interfaces provide reference points for connecting the EPS to heterogeneous network to facilitate interworking and seamless mobility.

1. S2a Interface: It provides the user plane with related control and mobility support between trusted non-3GPP IP access and the Packet Data Network Gateway. S2a is based on Proxy Mobile IP. To enable access via trusted non-3GPP IP accesses that do not support PMIP, S2a also supports Client Mobile IPv4 Foreign Agent (FA) mode.
2. S2c interface: It provides the user plane with related control and mobility support between UE and P-GW. This reference point is implemented over trusted and/or untrusted non-3GPP Access and/or 3GPP access. This interface is based on Client Mobile IP co-located mode.
3. S3 interface: It is the interface between Serving GPRS Support Node (SGSN) and MME and it enables user and bearer information exchange for inter 3GPP access network mobility in idle and/or active state. It is based on Gn reference point as defined between SGSNs.
4. S4 interface: It provides the user plane with related control and mobility support between SGSN and the S-GW and is based on the legacy Gn reference point as defined between SGSN and Gateway GPRS Support Node (GGSN).
5. S8 interface: Inter-PLMN reference point providing user and control plane between the Serving GW in the Visitor Public Land Mobile Network (VPLMN) and the P-GW in the Home PLMN (HPLMN). S8 is the inter PLMN variant of S5.
6. S9 interface: provides transfer of (QoS) policy and charging control information between the Home PCRF and the Visited PCRF in order to support local breakout function.
7. S10 interface: Reference point between MMEs for MME relocation and MME to MME information transfer.
8. S12 interface: Reference point between UTRAN and S-GW for user plane tunneling when Direct Tunnel is established. It is based on the Iu-u/Gn-u reference point using the GTP-U protocol as defined between SGSN and UTRAN or respectively between SGSN and GGSN. Usage of S12 is an operator configuration option.
9. S13 interface: It enables UE identity check procedure between MME and EIR.
10. Wn* interface: This is the reference point between the untrusted Non-3GPP IP Access and the ePDG. Traffic on this interface for a UE initiated tunnel has to be forced towards ePDG.



E. Service Access Interfaces

These include reference point user to connect the subscriber to desired IP services.

1. SGi interface: It is the reference point between the P-GW and the packet data network. Packet Data Network may be an operator-external public or private packet data network or an intra-operator packet data network, e.g. for provision of IMS services. This reference point corresponds to Gi for 2G/3G accesses.
2. Rx+ Interface: The Rx reference point resides between the Application Function and the PCRF.

IV. PROTOCOL ARCHITECTURE

The protocol stack for the LTE control and user planes are shown in Figures 2 and 3 respectively.

A. Air Interface Protocol Stack

The protocol stack of the LTE-Uu is comprised of the sub-layers grayed in Fig. 2 (for the control plane) and Fig. 3 (for the user plane).

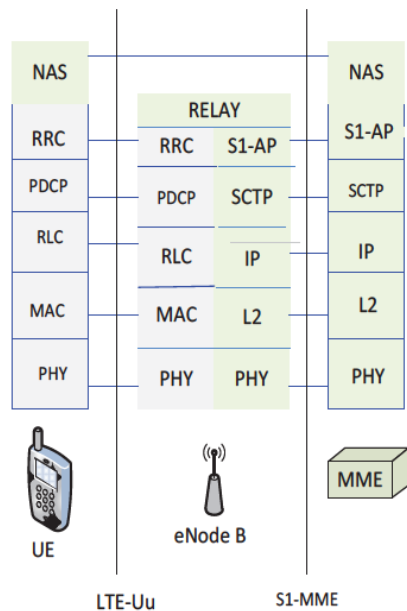

Fig. 2: LTE Control Plane Protocol Stack

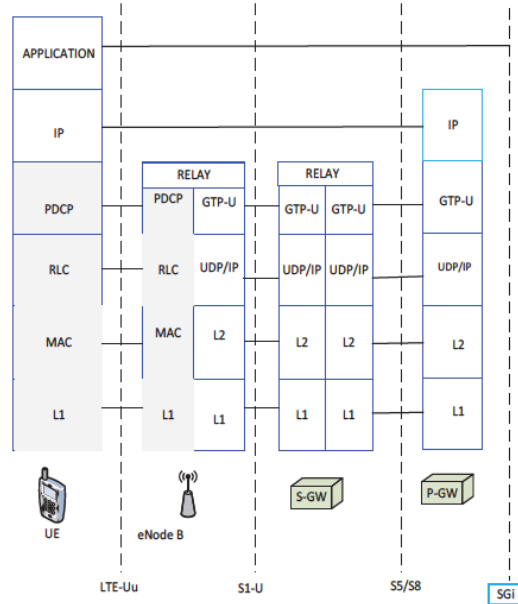

Fig. 3: LTE User Plane Protocol Stack

The RRC (Radio Resource Control) is the signaling connection across the LTE-Uu. Some of the main services and functions of this sub-layer include: mobility control, QoS management functions, radio bearer control, connection management and measurement control.

Packet Data Convergence Protocol (PDCP) Implements functions such as robust packet header compression and decompression, ciphering and deciphering, transfer of user user data et cetera. The main functions of the PDCP for the control plane involve ciphering and integrity protection and transfer of control plane data.

The Radio Link Control (RLC) performs segmentation and concatenation to optimize the use of available resource, and tracks packets that were sent or received. To this end, the RLC proposes three modes of transmission: Transparent Mode (TM), Unacknowledged Mode (UM) and Acknowledged Mode (AM) [4].

The MAC (Medium Access Control) sub-layer handles uplink and downlink scheduling, logical channel multiplexing and hybrid-ARQ retransmissions. It also determines the transport channel to be used. Logical channels (control and traffic) exist at the top of the MAC.

The function of the PHY (Physical) sub-layer is to provide data transport services on physical channels to the upper RLC and MAC sub-layers [5].

Thus, it is responsible for the actual radio transmission, and includes coding for forward error correction, modulation, bit interleaving, scrambling and other functions needed to minimize errors over the radio



link. It also manages the operation of hybrid ARQ (HARQ).

The NAS (Non Access Stratum) lies between the UE and MME. It executes functions and procedures that are completely independent of the access technology. These features include: authentication, security control procedures, idle mode mobility handling, idle mode paging procedures, charging and session management.

A. S1 Protocol Stack

Fig. 2 shows the protocol structure of the S1 control plane. It is based on Stream Control Transmission Protocol/IP (SCTP/IP) stack. SCTP inherits some features from TCP, which facilitates reliable delivery of signaling messages. The S1-AP (S1 Application Protocol) handles individual connection and then multiplexes multiple individual connections to the SCTP. The IP protocol can be version 4 or version 6.

The user plane uses GTP-U over User Datagram Protocol/IP (UDP/IP) for channeling user subscriber data over the S1 interface. GTP-U has an inherent facility to identify tunnels and also to facilitate intra 3GPP mobility. Both IP version number, and L2 (data link layer) can be implemented as appropriate.

B. X2 Protocol Stack

The X2 protocol stack (shown in Fig. 4) has a similar arrangement with that of S1.

The X2 control plane handles tasks that include handover cancellation, control of user plane tunnels between source eNB and target eNB, load management and error handling functions. The user plane protocol uses GTP-U (GPRS Tunneling Protocol-User) over UDP/IP to relay end-user packets between the eNBs. It supports tunneling functions such as identification of packets and packet loss management. X2 user plane and S1 user plane use the same user plane protocol to minimize protocol processing for the eNB during data tunneling.

V. CONCLUSION

The LTE network has a relatively simple and flat architecture, which is a transformation from complicated hierarchical systems to simple flat architectures. This has the effect of substantial reduction in delays within the network. The IP-based radio and core network comes with the advantage of lower cost and scalability. User data between the UE and Packet Data Network are tunneled using various standard interface and protocols across the different network elements. The protocol structure is split into two domains namely: the user plane protocol stack and the control plane protocol stack. The functional layout of the protocol stacks enhances efficient processing of IP packets.

REFERENCES

- [1] Erik Dahlman et al., *4G LTE/LTE-advanced for Mobile Broadband*, 1st edition, UK: Elsevier, 2011.
- [2] ETSI TS 136 300 V10.4.0, "Evolved Universal Terrestrial Radio Access (E-UTRA) and Evolved Universal Terrestrial Radio Access Network (E-UTRAN): overall description," June 2011.
- [3] Utra-Utran Long Term Evolution (LTE) and 3GPP System Architecture Evolution (SAE). Available at www.3gpp.org
- [4] 3GPP TS 23.402, "Architecture enhancements for non-3GPP accesses", Available at <http://www.3gpp.org>
- [5] Pierre Lescuyer and Thierry Lucidarme, "Evolved Packet System: The LTE and SAE Evolution of 3G UMTS", west Sussex, UK, 2008.