



US008255323B1

(12) **United States Patent**
Casey et al.

(10) **Patent No.:** **US 8,255,323 B1**
(45) **Date of Patent:** **Aug. 28, 2012**

(54) **MOTION BASED PAYMENT CONFIRMATION**

(75) Inventors: **Brandon J Casey**, San Jose, CA (US);
Gary Wipfler, Los Altos, CA (US); **Erik Cressall**, San Jose, CA (US)

(73) Assignee: **Apple Inc.**, Cupertino, CA (US)

(*) Notice: Subject to any disclaimer, the term of this patent is extended or adjusted under 35 U.S.C. 154(b) by 690 days.

(21) Appl. No.: **12/351,714**

(22) Filed: **Jan. 9, 2009**

(51) **Int. Cl.**
G06Q 40/00 (2012.01)

(52) **U.S. Cl.** **705/39; 705/35; 705/42**

(58) **Field of Classification Search** **705/35, 705/42**

See application file for complete search history.

(56) **References Cited**

U.S. PATENT DOCUMENTS

5,590,038	A *	12/1996	Pitroda	705/41
5,953,710	A	9/1999	Fleming	
6,609,113	B1	8/2003	O'Leary et al.	
6,749,114	B2	6/2004	Madani	
6,903,681	B2	6/2005	Faris	
7,249,092	B2	7/2007	Dunn et al.	
7,331,518	B2	2/2008	Rable	
7,333,947	B2	2/2008	Wiebe et al.	
7,357,310	B2	4/2008	Calabrese et al.	
7,533,059	B2 *	5/2009	Gattis et al.	705/40
2002/0010631	A1 *	1/2002	Sato et al.	705/14
2002/0052805	A1 *	5/2002	Seki et al.	705/27
2002/0082995	A1	6/2002	Christie, IV	
2003/0028481	A1	2/2003	Flitcroft et al.	
2003/0135463	A1	7/2003	Brown	
2004/0034598	A1	2/2004	Robinson	
2004/0083394	A1	4/2004	Brebner	
2005/0086692	A1 *	4/2005	Dudkiewicz et al.	725/46
2005/0246278	A1	11/2005	Gerber et al.	

2006/0006226	A1	1/2006	Fitzgerald et al.	
2006/0010042	A1	1/2006	Gianakis et al.	
2006/0031162	A1	2/2006	Brundage et al.	
2006/0052109	A1 *	3/2006	Ashman et al.	455/440
2006/0074698	A1	4/2006	Bishop et al.	
2006/0085357	A1	4/2006	Pizarro	
2006/0105742	A1	5/2006	Kim et al.	
2006/0131390	A1	6/2006	Kim	
2007/0089061	A1 *	4/2007	Terada	715/723

(Continued)

FOREIGN PATENT DOCUMENTS

EP 1696626 8/2006
(Continued)

OTHER PUBLICATIONS

ewallet: users guide and reference Ilium Software Copyright 1997-2008 No specific date recorded.*

(Continued)

Primary Examiner — William Rankins

(74) *Attorney, Agent, or Firm* — Fletcher Yoder PC

(57) **ABSTRACT**

Methods and devices for confirming payment transactions are provided. In one embodiment, an electronic device may include a graphical user interface (GUI) with one or more graphical elements that may be moved by a user to confirm or decline a payment transaction using a selected payment instrument. For example, a user may drag the graphical element to a confirmation position via a touch screen of the electronic device. In another example, a motion sensing device, such as an accelerometer, may sense movement of the electronic device and move the graphical element in response to the motion. Upon confirmation, payment information for the payment transaction may be transmitted to a merchant or payment recipient. Various additional methods, machine-readable media, and devices for confirming payment transactions are provided.

8 Claims, 11 Drawing Sheets

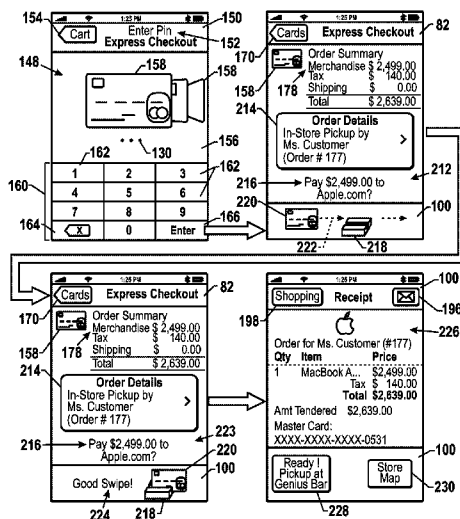

US 8,255,323 B1

Page 2

U.S. PATENT DOCUMENTS

2007/0118475 A1 5/2007 Picciallo et al.
2008/0006685 A1 1/2008 Rackley, III et al.
2008/0010190 A1 1/2008 Rackley, III et al.
2008/0010191 A1 1/2008 Rackley, III et al.
2008/0010193 A1 1/2008 Rackley, III et al.
2008/0010204 A1 1/2008 Rackley, III et al.
2008/0016232 A1 1/2008 Yared
2008/0027844 A1 1/2008 Little et al.
2008/0040265 A1 2/2008 Rackley, III et al.
2008/0046362 A1* 2/2008 Easterly 705/40
2008/0078831 A1 4/2008 Johnson et al.
2008/0108324 A1 5/2008 Moshir
2008/0126145 A1 5/2008 Rackley
2008/0149729 A1* 6/2008 Philips 235/487
2008/0162346 A1 7/2008 Aaron
2008/0166998 A1 7/2008 Sun et al.
2008/0207203 A1 8/2008 Arthur et al.
2008/0208743 A1 8/2008 Arthur
2008/0294556 A1* 11/2008 Anderson 705/44

2009/0098854 A1 4/2009 Park
2009/0133499 A1* 5/2009 Cato 73/514.16
2009/0203399 A1* 8/2009 Rofougaran 455/556.1

FOREIGN PATENT DOCUMENTS

EP 1696626 A1 * 8/2006
JP 2007323613 12/2007

OTHER PUBLICATIONS

Ilium Software, "Users Guide and Reference: Version 6.1," Jul. 2008 (available electronically at: www.iliumsoft.com/dl/doc/eWallet.pdf (accessed Apr. 9, 2009)).
U.S. Appl. No. 12/351,687, filed Jan. 9, 2009, Casey et al.
U.S. Appl. No. 12/351,649, filed Jan. 9, 2009, Casey et al.
U.S. Appl. No. 12/351,674, filed Jan. 9, 2009, Casey et al.
U.S. Appl. No. 12/351,724, filed Jan. 9, 2009, Casey et al.

* cited by examiner

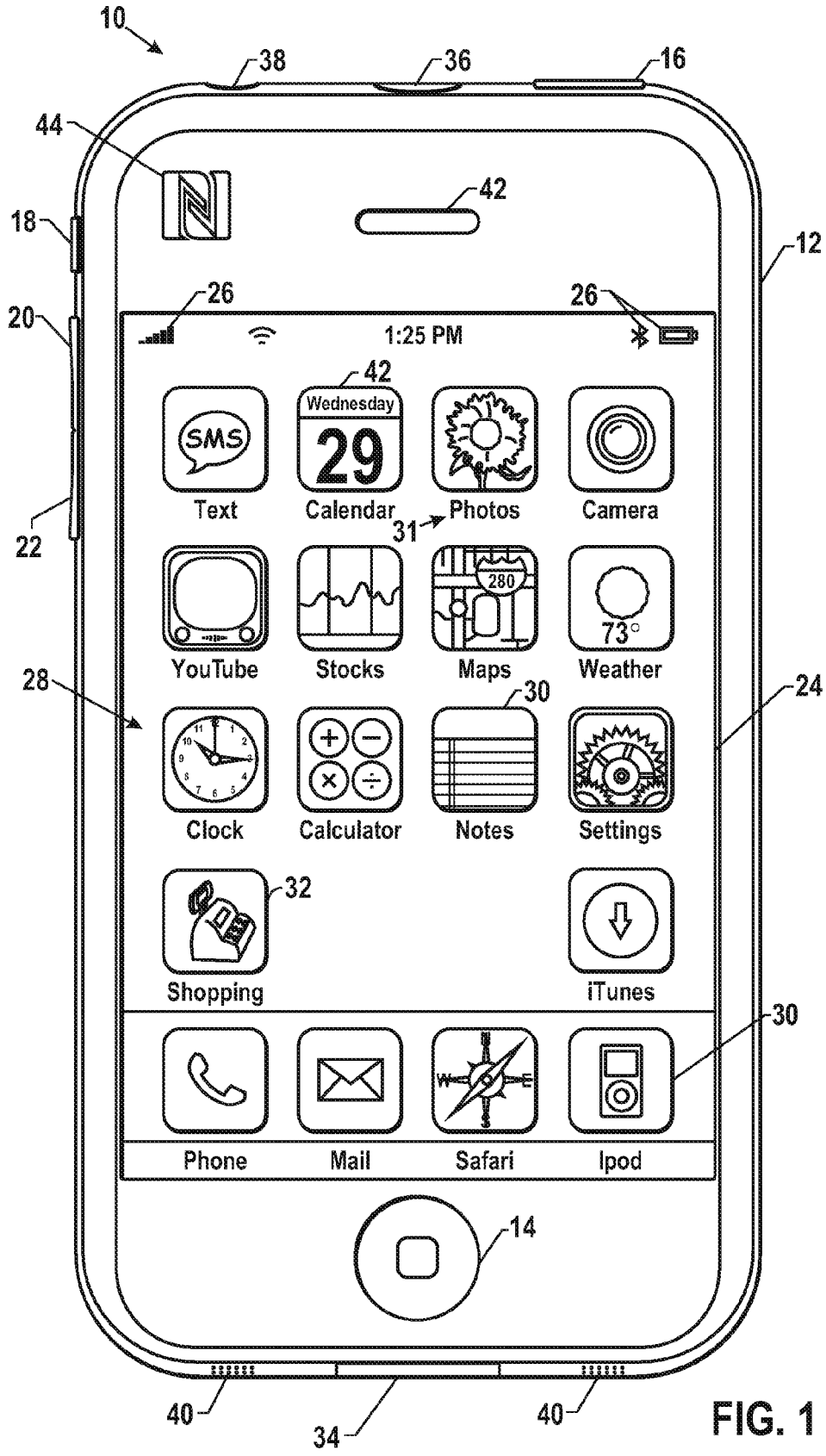

FIG. 1

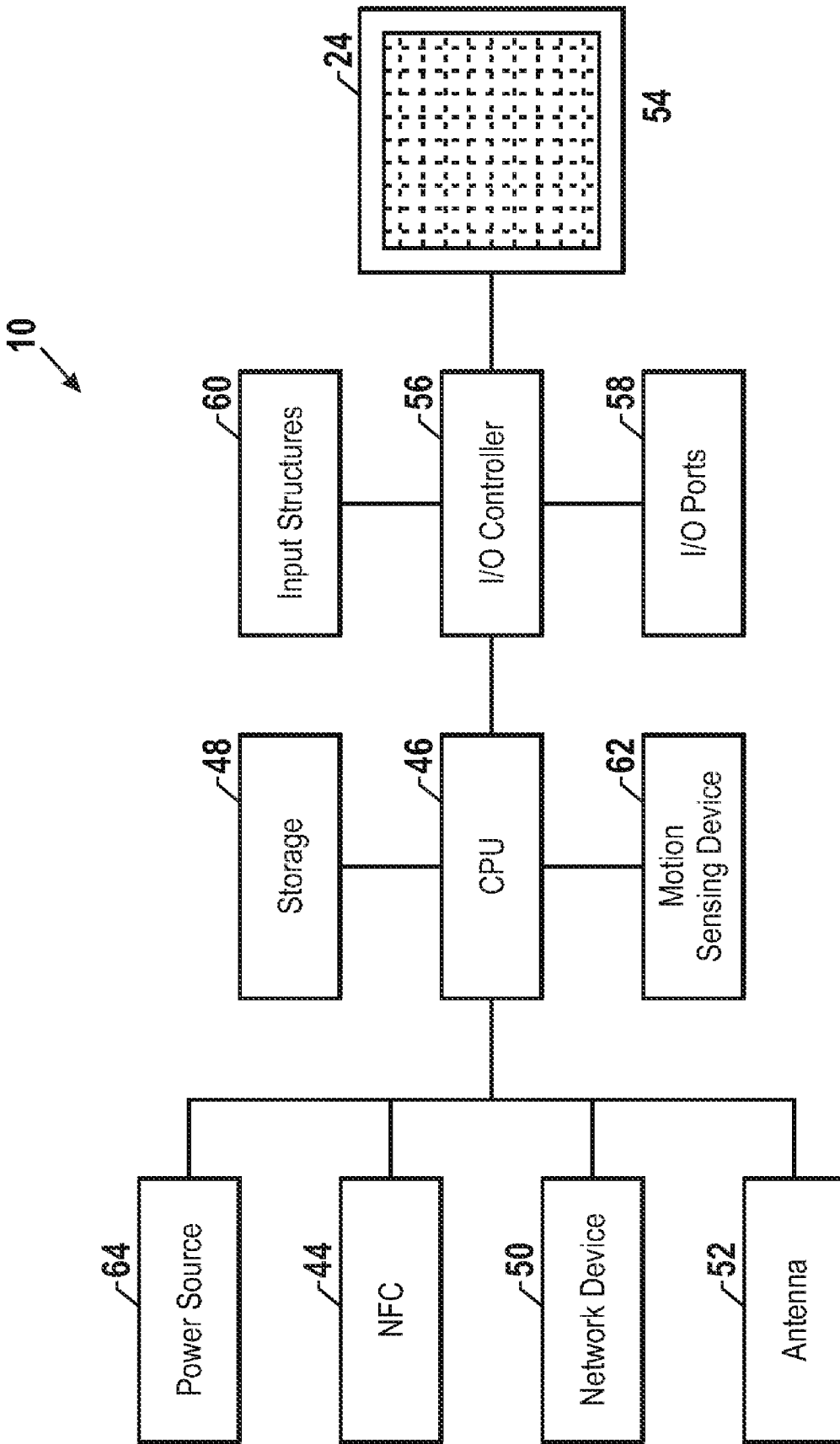

FIG. 2

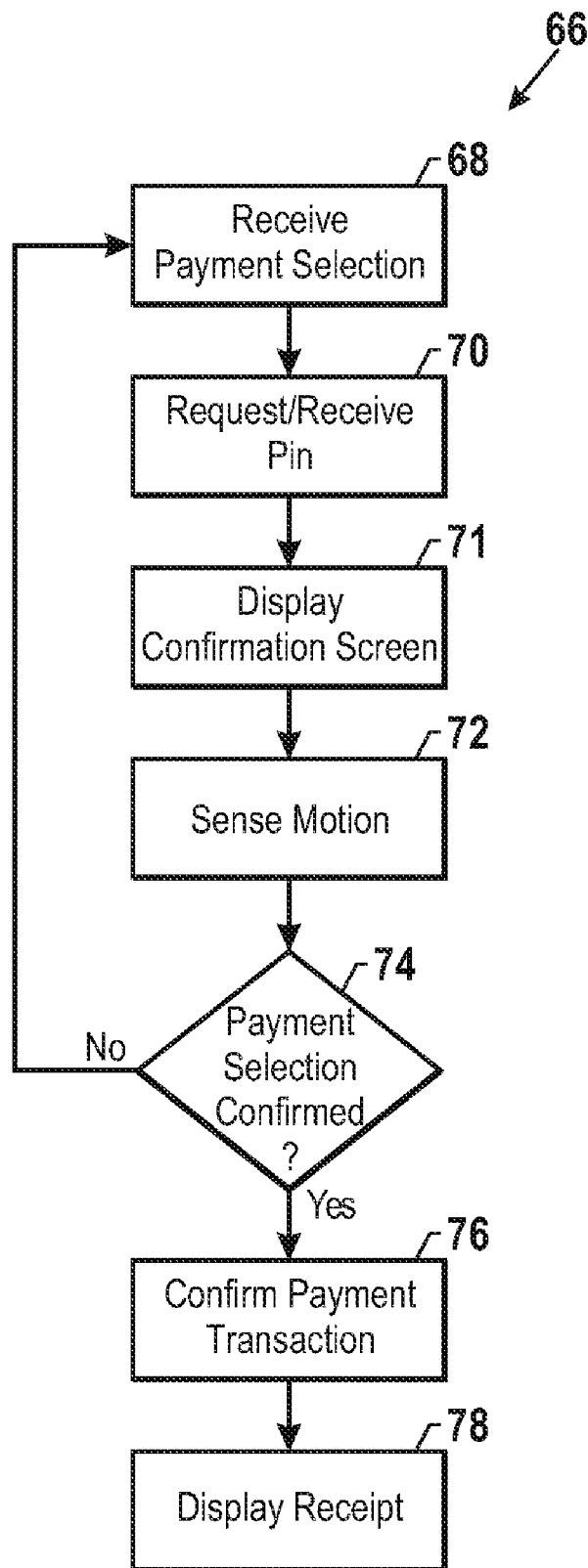

FIG. 3

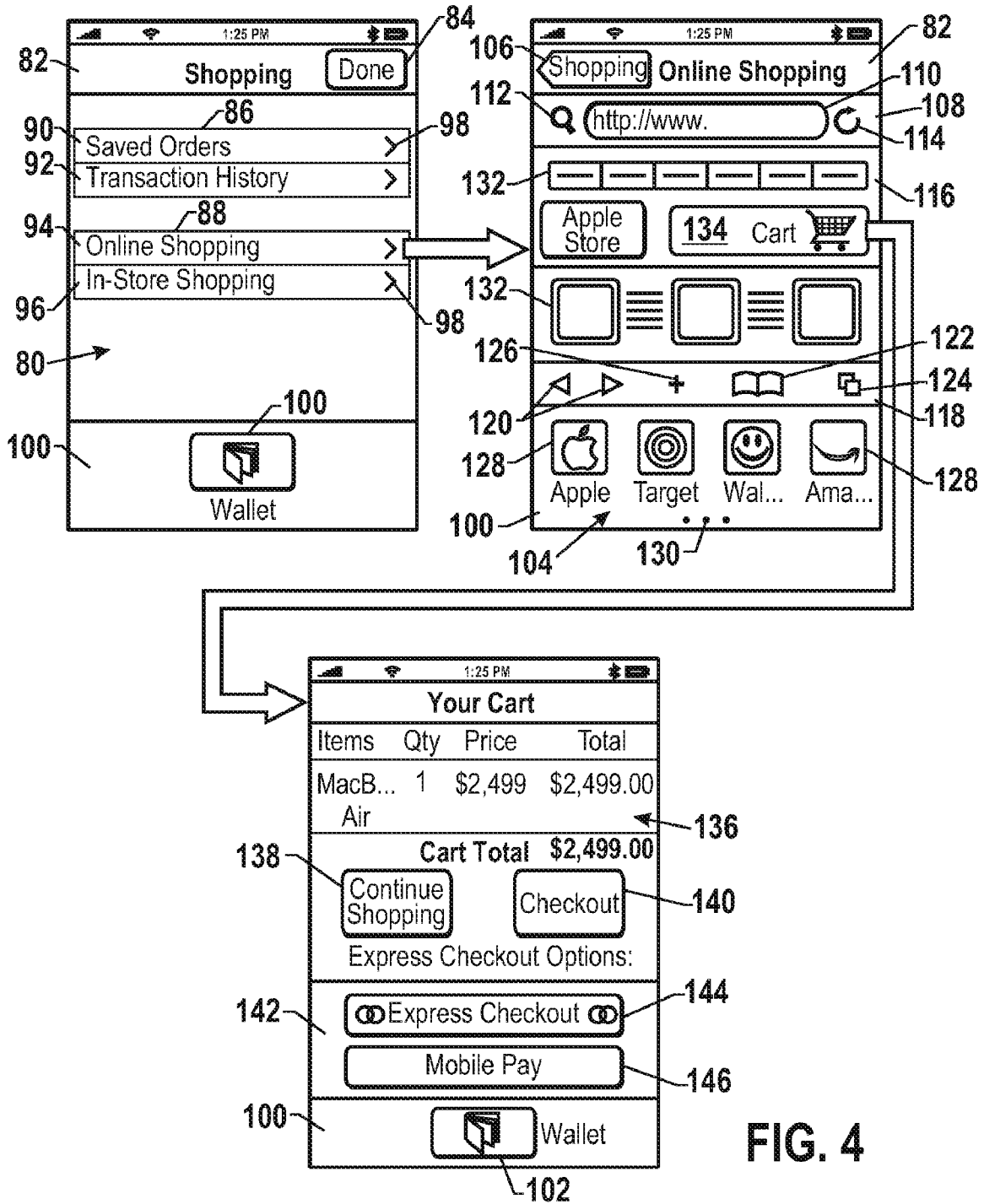

FIG. 4

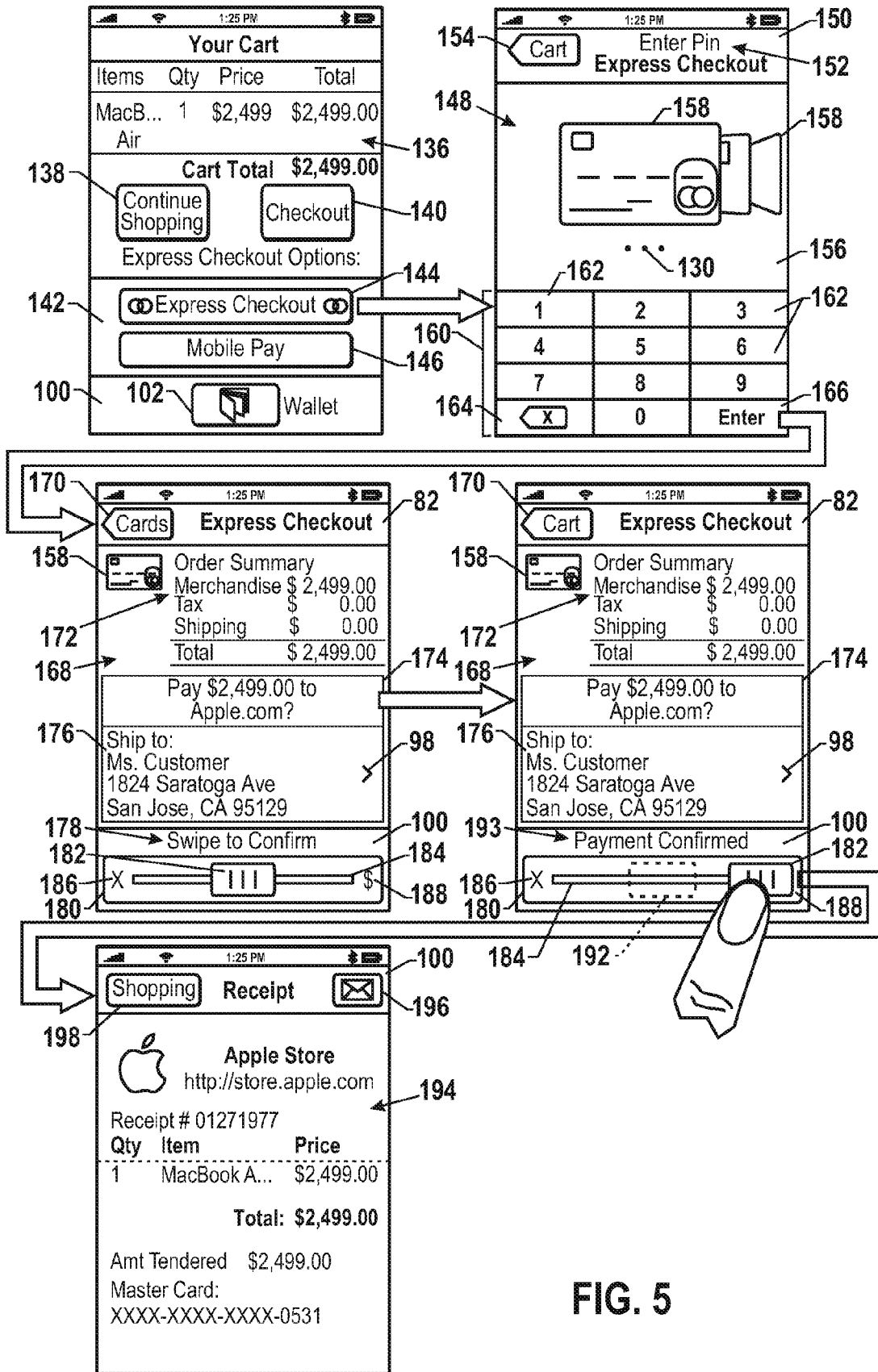

FIG. 5

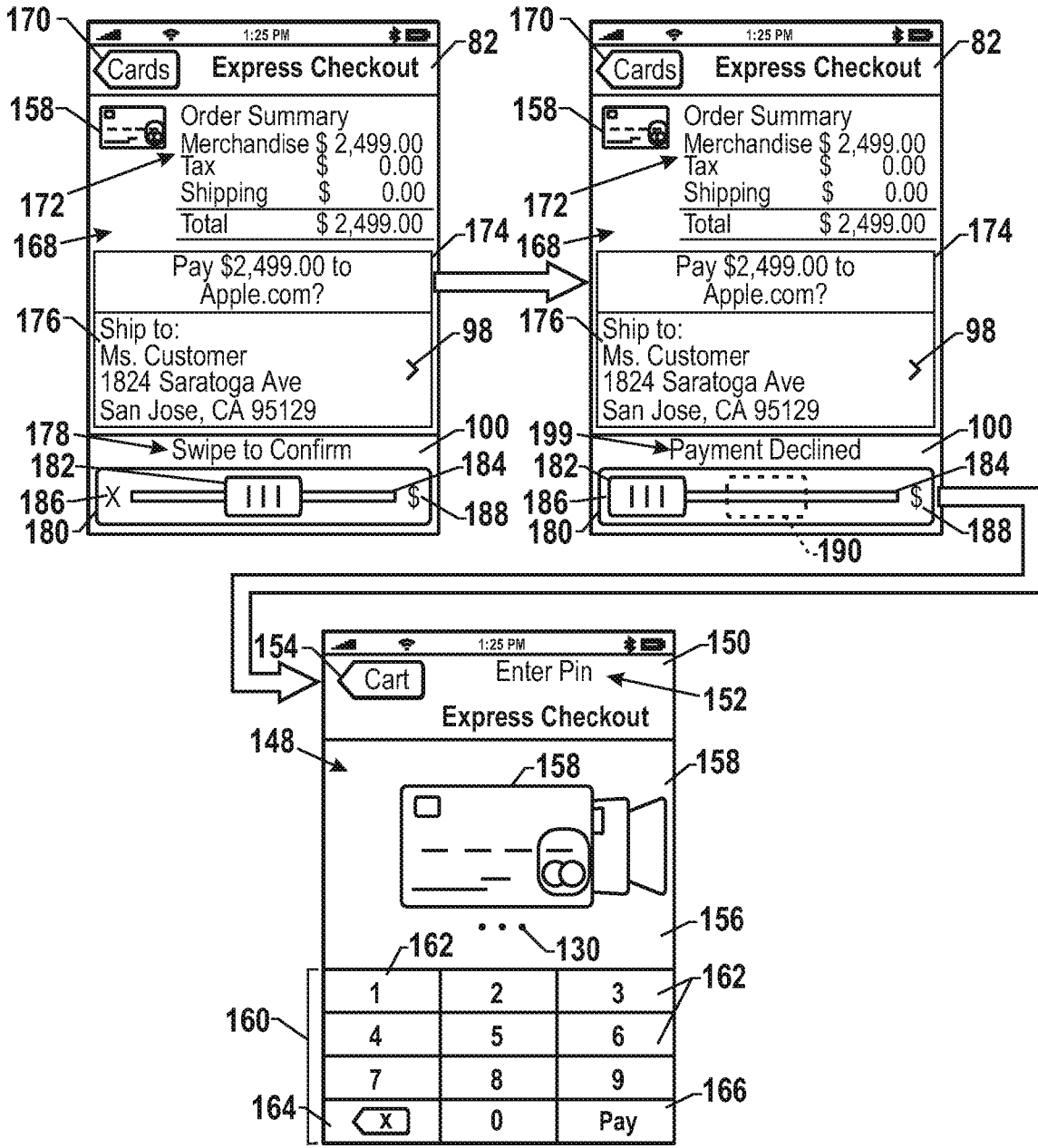

FIG. 6

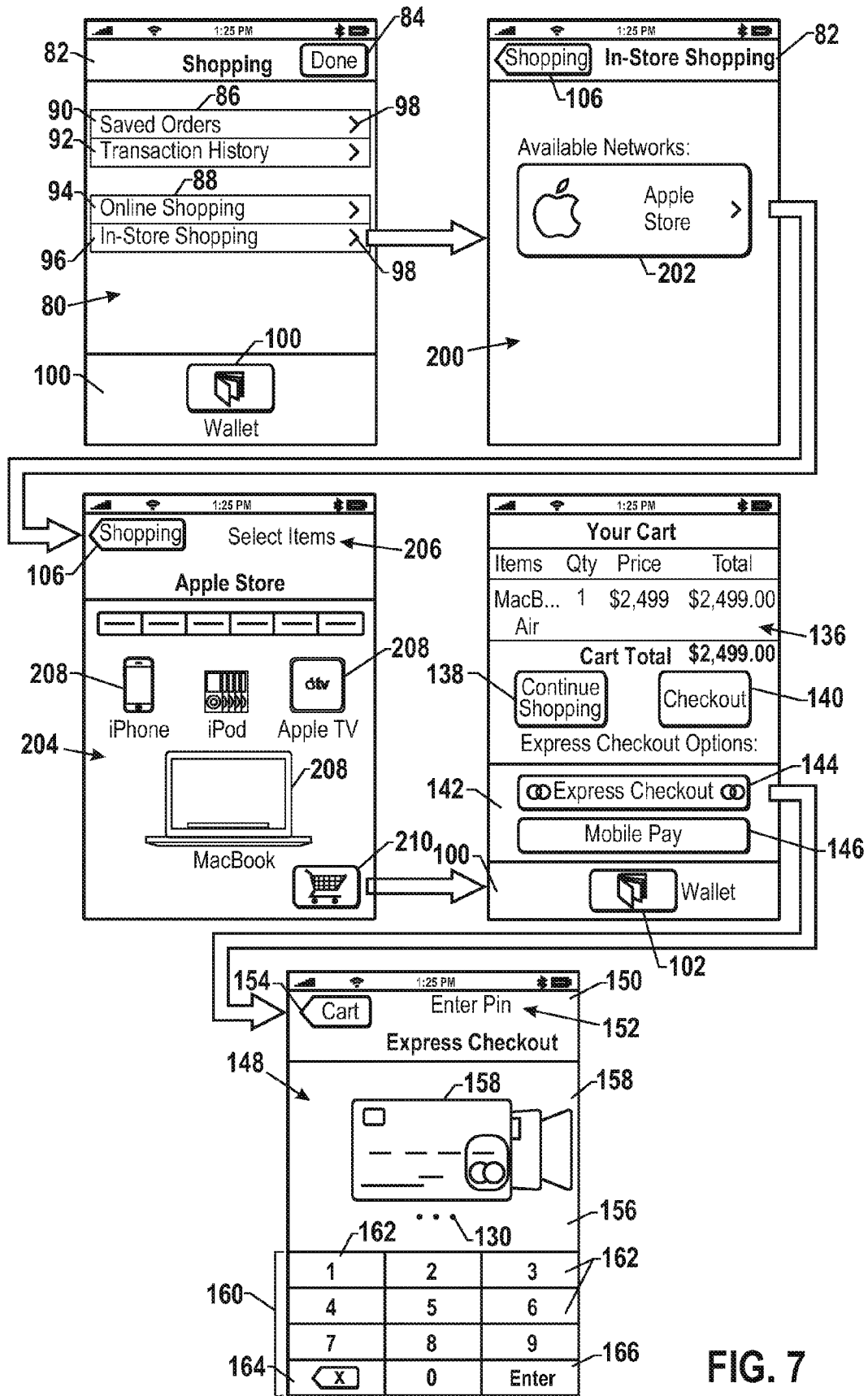

FIG. 7

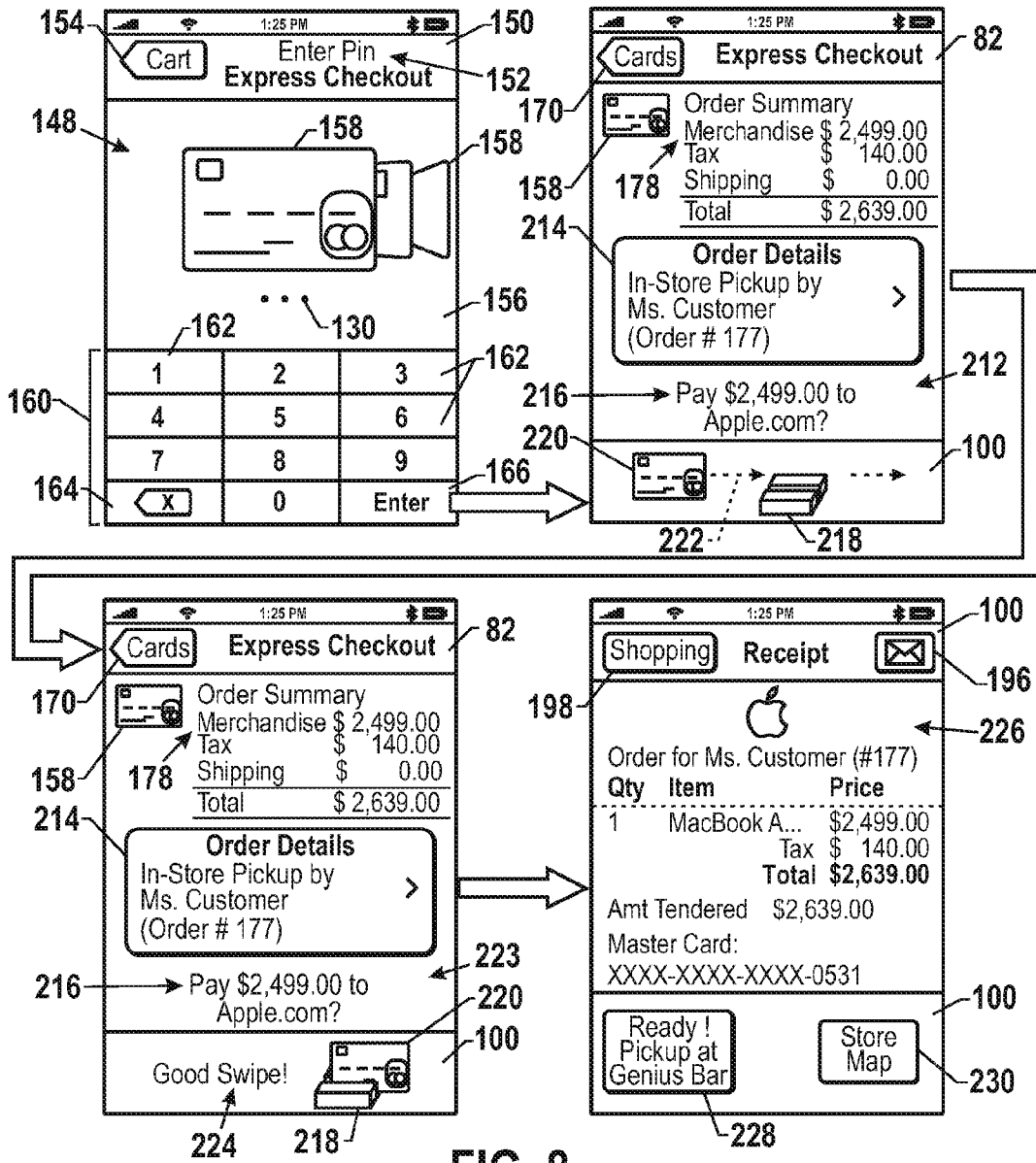

FIG. 8

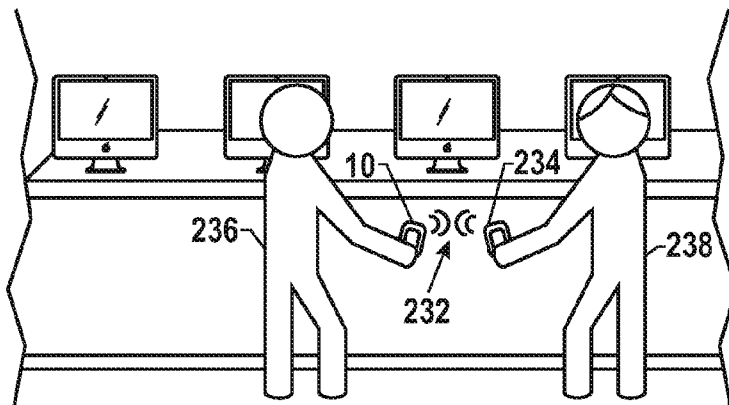
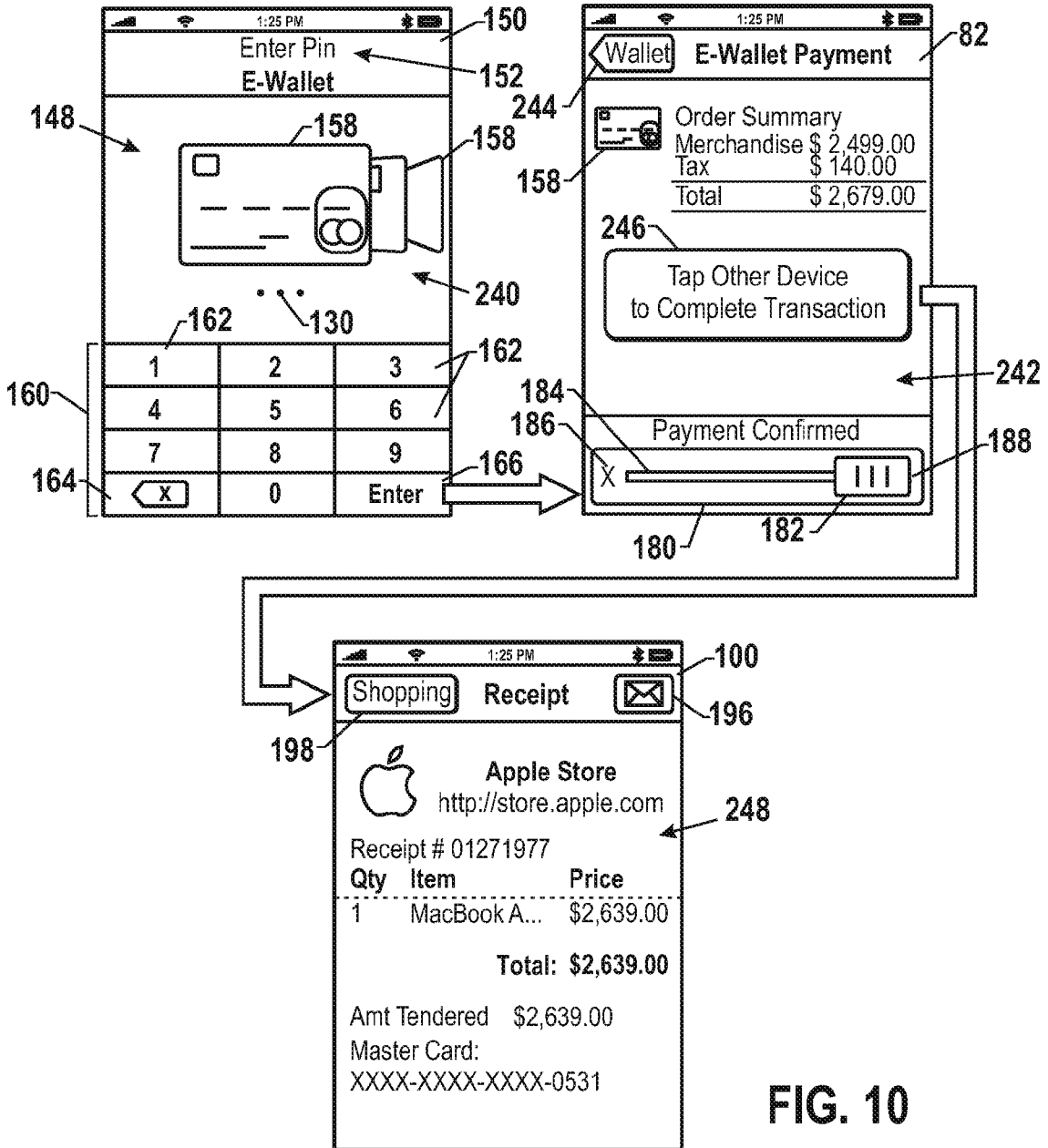

FIG. 9



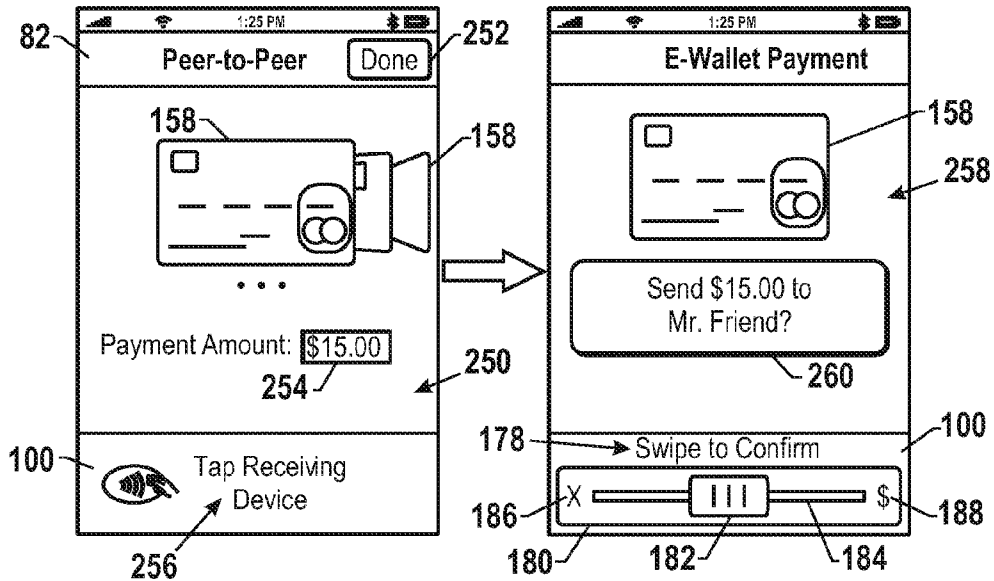

FIG. 11

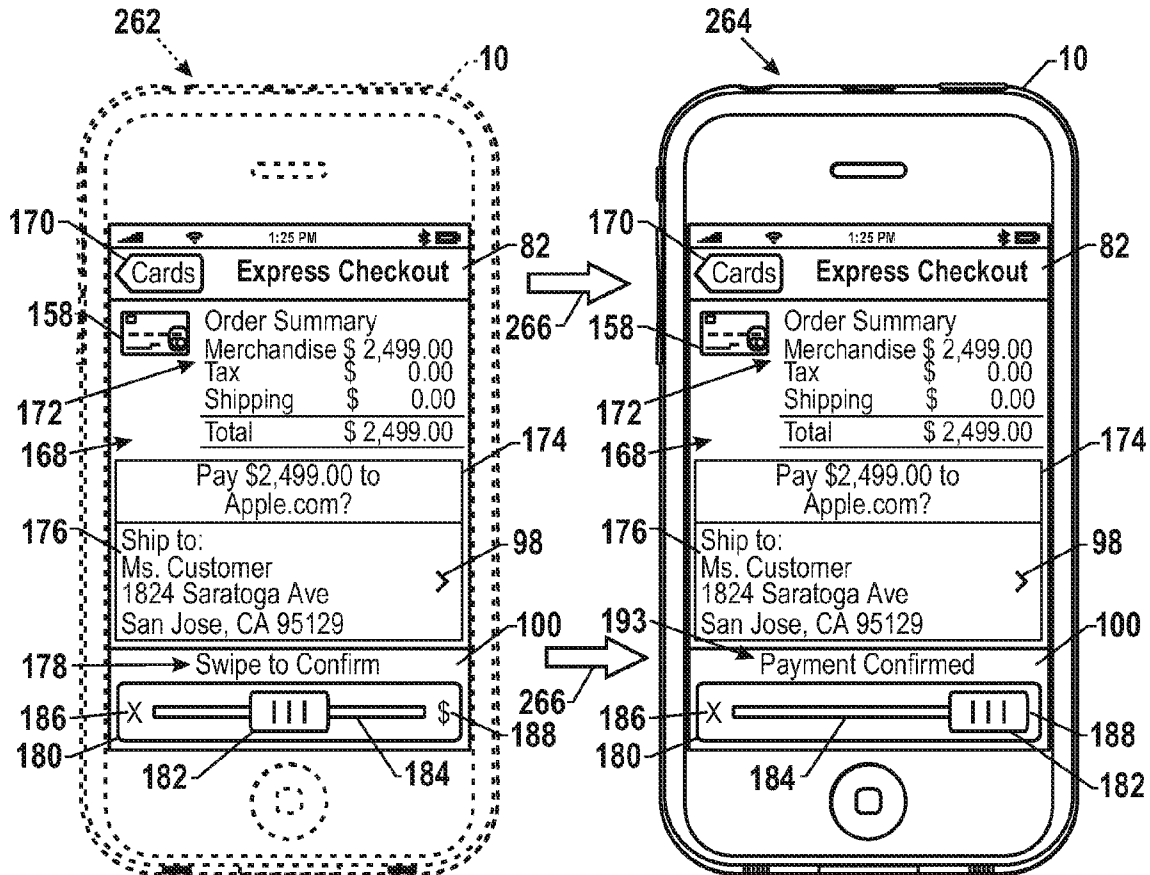

FIG. 12

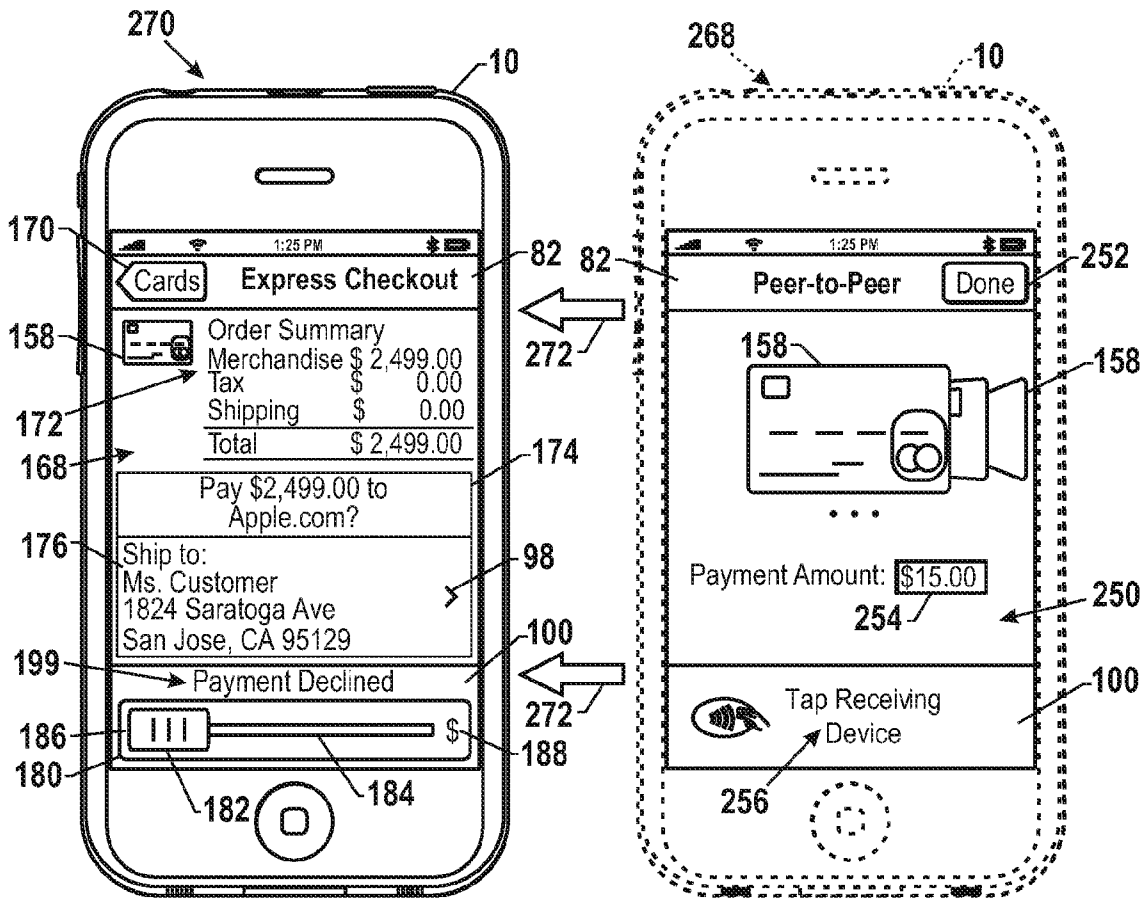

FIG. 13

MOTION BASED PAYMENT CONFIRMATION**BACKGROUND OF THE INVENTION****1. Field of the Invention**

The present invention relates generally to electronic devices, and, more particularly to graphical user interfaces configured to receive motion based inputs for confirming a payment transaction.

2. Description of the Related Art

This section is intended to introduce the reader to various aspects of art that may be related to various aspects of the present invention, which are described and/or claimed below. This discussion is believed to be helpful in providing the reader with background information to facilitate a better understanding of the various aspects of the present invention. Accordingly, it should be understood that these statements are to be read in this light, and not as admissions of prior art.

Payment transactions increasingly occur without the use of physical payment objects such as credit cards or cash. For example, online purchases may be made using credit card information stored in an online account maintained by a merchant or by a payment service such as PayPal. Further, financial account information may be stored on electronic devices and transferred using contactless means, such as near field communication (NFC), radio-frequency identification (RFID), or networking, to complete payment transactions.

The increased use of electronic and/or contactless payments may allow payment transactions to occur at a fast pace without the need for payment objects. However, due to the speed and virtual nature of modern payment transactions, consumers may not fully appreciate the consequences of authorizing a payment transaction or may inadvertently authorize a payment transaction.

SUMMARY

Certain aspects commensurate in scope with the originally claimed invention are set forth below. It should be understood that these aspects are presented merely to provide the reader with a brief summary of certain forms of the invention might take and that these aspects are not intended to limit the scope of the invention. Indeed, the invention may encompass a variety of aspects that may not be set forth below.

The present disclosure generally relates to techniques for confirming a payment transaction. In accordance with one disclosed embodiment, an electronic device may include a graphical user interface (GUI) with one or more graphical elements that may be moved by a user to confirm or decline a payment transaction. The graphical elements may be configured to virtually represent a swipe of a credit card. For example, in one embodiment, the GUI may display a two position slide bar that may be moved in one direction to confirm the payment transaction and in another direction to decline the payment transaction. In accordance with another embodiment, the GUI may display an image of a credit card that may be moved towards an image of a credit card terminal to confirm the payment transaction.

In certain embodiments, the graphical elements for confirming a payment transaction may be displayed in response to selection of a payment instrument through a touch screen of an electronic device. For example, credit cards may be digitally represented within an electronic wallet or an online payment system. After movement of the graphical elements, the electronic device may transmit a confirmation message to initiate payment with the selected payment instrument. The movable graphical elements may be used to confirm payment

transactions in a wide variety of environments such as peer-to-peer transactions, online shopping transactions, and purchases made within brick and mortar stores.

Various refinements of the features noted above may exist in relation to various aspects of the present disclosure. Further features may also be incorporated in these various aspects as well. These refinements and additional features may exist individually or in any combination. For instance, various features discussed below in relation to one or more of the illustrated embodiments may be incorporated into any of the above-described aspects alone or in any combination. Again, the brief summary presented above is intended only to familiarize the reader with certain aspects and contexts of embodiments of the present disclosure without limitation to the claimed subject matter.

BRIEF DESCRIPTION OF THE DRAWINGS

These and other features, aspects, and advantages of the present disclosure will become better understood when the following detailed description is read with reference to the accompanying drawings in which like characters represent like parts throughout the drawings, wherein:

FIG. 1 is a front view of an electronic device in accordance with one embodiment;

FIG. 2 is a simplified block diagram of the device of FIG. 1 in accordance with one embodiment;

FIG. 3 is a flowchart depicting a method for confirming a payment transaction in accordance with one embodiment;

FIG. 4 is a view of screens of the device of FIG. 1 illustrating an online shopping transaction in accordance with one embodiment;

FIG. 5 is a view of screens of the device of FIG. 1 illustrating confirmation of an online shopping payment through a touch screen in accordance with one embodiment;

FIG. 6 is a view of screens of the device of FIG. 1 illustrating rejection of an online shopping payment in accordance with one embodiment;

FIG. 7 is a view of screens of the device of FIG. 1 illustrating an in-store shopping transaction in accordance with one embodiment;

FIG. 8 is a view of screens of the device of FIG. 1 illustrating confirmation of an in-store shopping payment in accordance with one embodiment;

FIG. 9 is an illustration of a payment transaction between two electronic devices in accordance with one embodiment;

FIG. 10 a view of screens of the device of FIG. 1 illustrating confirmation of a payment from an electronic wallet in accordance with one embodiment;

FIG. 11 a view of screens of the device of FIG. 1 illustrating confirmation of a peer-to-peer payment in accordance with one embodiment;

FIG. 12 is a front view of the device of FIG. 1 illustrating confirmation of a payment transaction through motion of the device in accordance with one embodiment; and

FIG. 13 is a front view of the device of FIG. 1 illustrating rejection of a payment transaction through motion of the device in accordance with one embodiment.

DETAILED DESCRIPTION OF SPECIFIC EMBODIMENTS

One or more specific embodiments of the present invention will be described below. In an effort to provide a concise description of these embodiments, not all features of an actual implementation are described in the specification. It should be appreciated that in the development of any such actual

implementation, as in any engineering or design project, numerous implementation-specific decisions must be made to achieve the developers' specific goals, such as compliance with system-related and business-related constraints, which may vary from one implementation to another. Moreover, it should be appreciated that such a development effort might be complex and time consuming, but would nevertheless be a routine undertaking of design, fabrication, and manufacture for those of ordinary skill having the benefit of this disclosure.

The present disclosure is directed to techniques for confirming a payment transaction on an electronic device that includes a touch screen. Through the touch screen, a user may select a payment instrument, such as a credit card or debit card, for performing a payment transaction. In certain embodiments, the payment transaction may include purchasing retail goods online or in a brick and mortar store. In other embodiments, the payment transaction may include peer-to-peer transactions where money may be exchanged between private parties.

After selection of a payment instrument, the electronic device may display one or more graphical elements for confirming the payment transaction. In certain embodiments, a user may slide the graphical elements to a confirmation position via the touch screen. In other embodiments, a user may move the device in a specified direction or manner to move the graphical elements to the confirmation position. Upon confirmation, the electronic device may transmit transaction and account information, such as a sender and/or recipient identifier, payment instrument identifier, account number, payment amount, remittance advice details (including, but not limited to, line item details, merchant information, date and time, tax details, and shipping costs), device location, shipping location, billing address, and/or confirmation message, to a merchant or payment recipient to enable processing of the payment transaction. The account and transaction information may optionally be encrypted and/or digitally signed by the merchant's and sender's public keys.

FIG. 1 illustrates an electronic device **10** that may make use of the techniques for confirming a payment transaction as described above. It should be noted that while the techniques will be described below in reference to the illustrated electronic device **10** (which may be a cellular telephone, a media player for playing music and/or video, a personal data organizer, or any combination thereof), the techniques described herein are usable with any electronic device that includes a touch screen and GUI. For example, in certain embodiments, the payment confirmation techniques may be employed at an electronic touch-screen kiosk located in a retail store or other location. In other embodiments, the payment techniques may be employed on a desktop computer having a suitable touch-screen or motion-sensing interface.

As illustrated in FIG. 1, the electronic device **10** may be a handheld device incorporating the functionality of one or more portable devices, such as a media player, a cellular phone, a personal data organizer, and so forth. Depending, of course, on the functionalities provided by the electronic device **10**, a user may scan articles of merchandise, listen to music, play games, record video, take pictures, and place telephone calls, while moving freely with the device **10**. In addition, the electronic device **10** may allow a user to connect to and communicate through the Internet or through other networks, such as local or wide area networks. For example, the electronic device **10** may allow a user to communicate using e-mail, text messaging, instant messaging, or other forms of electronic communication. The electronic device **10** also may communicate with other devices using short-range connections, such as Bluetooth and near field communica-

tion. By way of example, the electronic device **10** may be a model of an iPod® or iPhone®, or a derivative thereof, available from Apple Inc. of Cupertino, Calif.

In the depicted embodiment, the device **10** includes an enclosure **12** that protects the interior components from physical damage and shields them from electromagnetic interference. The enclosure **12** may be formed from any suitable material such as plastic, metal or a composite material and may allow certain frequencies of electromagnetic radiation to pass through to wireless communication circuitry within the device **10** to facilitate wireless communication.

The enclosure **12** includes user input structures **14**, **16**, **18**, **20**, and **22** through which a user may interface with the device. Each user input structure **14**, **16**, **18**, **20**, and **22** may be configured to control a device function when actuated. For example, the input structure **14** may include a button that when pressed causes a "home" screen or menu to be displayed on the device. The input structure **16** may include a button for toggling the device **10** between a sleep mode and a wake mode. The input structure **18** may include a two-position slider that silences a ringer for the cell phone application. The input structures **20** and **22** may include buttons for increasing and decreasing the volume output of the device **10**. In general, the electronic device **10** may include any number of user input structures existing in various forms including buttons, switches, control pads, keys, knobs, scroll wheels, or other suitable forms.

The device **10** also includes a display **24** that may display various images generated by the device. For example, the display **24** may show photos of merchandise, advertisements, movies, and/or data, such as text documents, work schedules, financial spreadsheets, text messages, and e-mail, among other things. The display **24** also may display system indicators **26** that provide feedback to a user, such as power status, signal strength, call status, external device connection, and the like. The display **24** may be any type of display such as a liquid crystal display (LCD), a light emitting diode (LED) display, an organic light emitting diode (OLED) display, or other suitable display. Additionally, the display **24** may include a touch-sensitive element, such as a touch screen.

The display **24** may be used to display a graphical user interface (GUI) **28** that allows a user to interact with the device. The GUI **28** may include various layers, windows, screens, templates, or other graphical elements that may be displayed in all, or a portion, of the display **24**. Generally, the GUI **28** may include graphical elements that represent applications and functions of the device **10**. The graphical elements may include icons and other images representing buttons, sliders, menu bars, and the like. In certain embodiments, the user input structure **14** may be used to display a home screen of the GUI **28**. For example, in response to actuation of the input structure **14**, the device may display graphical elements, shown here as icons **30**, of the GUI **28**. The icons **30** may correspond to various applications of the device **10** that may open upon selection of a respective icon **30**. The icons **30** may be selected via a touch screen included in the display **24**, or may be selected by user input structures, such as a wheel or button.

The icons **30** may represent various layers, windows, screens, templates, or other graphical elements that may be displayed in some or all of the areas of the display **24** upon selection by the user. Furthermore, selection of an icon **30** may lead to a hierarchical navigation process, such that selection of an icon **30** leads to a screen that includes one or more additional icons or other GUI elements. Textual indicators **31** may be displayed on or near the icons **30** to facilitate user interpretation of each icon **30**. It should be appreciated that

5

the GUI **30** may include various components arranged in hierarchical and/or non-hierarchical structures.

When an icon **30** is selected, the device **10** may be configured to open an application associated with that icon and display a corresponding screen. For example, when the Shopping icon **32** is selected, the device **10** may be configured to open an application for conducting online or in-store shopping. For each application, screens including additional icons or other GUI elements may be displayed on the display **24**. The application may present different GUI elements depending on the context and the device's environment. For example, if the device is in motion or in a modal state, the application may perform functions optimized to minimize user interaction. Environmental factors the device may evaluate include the degree or motion or acceleration, ambient light, time of day, location as determined by GPS or other location identification services, ambient/background volume/noise levels, communication channel signal strength, running applications or processes, connected peripherals such as headphones, microphone, or docking station, user interaction with any of the various input methods including the buttons and the touch screen, or the length of time since the aforementioned environmental factors have changed.

The electronic device **10** also may include various input and output (I/O) ports **34**, **36**, and **38** that allow connection of the device **10** to external devices. The I/O port **34** may be a connection port for transmitting and receiving data files, such as media files or customer order files. For example, the I/O port **34** may be a proprietary port from Apple Inc. In certain embodiments, the I/O port **34** may be used to connect an external scanning device, such as a barcode reader. The I/O port **36** may be a connection slot for receiving a subscriber identify module (SIM) card. The I/O port **38** may be an audio jack for connecting headphones or external speakers. In other embodiments, the device **10** may include any number of I/O ports configured to connect to a variety of external devices, including but not limited to a power source, a printer, a computer, and an intermediate device, such as a dock, for communicating with an external server. In certain embodiments, multiple ports may be included on the device. The ports may support any interface type, such as a universal serial bus (USB) port, serial connection port, Firewire port, IEEE-1394 port, or AC/DC power connection port.

The electronic device **10** may also include various audio input and output structures **40** and **42**. For example, the audio input structures **40** may include one or more microphones for receiving voice data from a user. The audio output structures **42** may include one or more speakers for outputting audio data, such as data received by the device **10** over a cellular network. Together, the audio input and output structures **40** and **42** may operate to provide telephone functionality. Further, in some embodiments, the audio input structures **40** may include one or more integrated speakers serving as audio output structures for audio data stored on the device **10**. For example, the integrated speakers may be used to play music stored in the device **10**.

The device **10** may further include a near field communication (NFC) device **44**. The NFC device **44** may be located within the enclosure **12**, and a mark or symbol on the exterior of the enclosure **12** may identify its location within the enclosure **12**. The NFC device **44** may allow for close range communication at relatively low data rates (424 kb/s), and may comply with standards such as ISO 18092 or ISO 21481, or it may allow for close range communication at relatively high data rates (560 Mbps), and may comply with the TransferJet® protocol. In certain embodiments, the communication may occur within a range of approximately 2 to 4 cm. Close range

6

communication with the NFC device **44** may take place via magnetic field induction, allowing the NFC device **44** to communicate with other NFC devices or to retrieve information from tags having radio frequency identification (RFID) circuitry. As discussed below, the NFC device **44** may provide a manner of connecting to a shopping website and communicating with an external server.

Additional details of the illustrative device **10** may be better understood through reference to FIG. **2**, which is a block diagram illustrating various components and features of the device **10** in accordance with one embodiment of the present invention. The block diagram includes the display **24** and the NFC interface **44** discussed above, as well as many other components.

The operation of the device **10** may be controlled by a central processing unit (CPU) **46** that provides the processing capability required to execute the operating system, programs, GUI **28**, and any other functions of the device **10**. The CPU **46** may include a single processor or it may include a plurality of processors. For example, the CPU **46** may include "general purpose" microprocessors, a combination of general and special purpose microprocessors, instruction set processors, graphics processors, video processors, and/or related chips sets, and/or special purpose microprocessors. The CPU **46** also may include on board memory for caching purposes.

Information used by the CPU **46** may be located within long-term storage **48**. The long-term storage **48** of electronic device **10** may be used for storing data required for the operation of the CPU **46** as well as other data required by the device **10**. For example, the storage **48** may store the firmware for the electronic device **10** that is used by the CPU **46**. The firmware may include an operating system, as well as other programs that enable various functions of the electronic device **10**, GUI functions, and/or processor functions. The storage **48** also may store components for the GUI **28**, such as graphical elements, screens, and templates. Additionally, the long term storage **48** may store data files such as media (e.g., music and video files), image data, software, preference information (e.g., media playback preferences), financial account information, wireless connection information (e.g., information that may enable the device **10** to establish a wireless connection, such as a telephone connection), subscription information (e.g., information that maintains a record of podcasts, television shows or other media to which a user subscribes), telephone information (e.g., telephone numbers), and any other suitable data. The long term storage **48** may be non-volatile memory such as one or more of a read only memory, flash memory, a hard drive, or any other suitable optical, magnetic, or solid-state computer readable media, as well as a combination thereof.

One or more network devices **50** may provide additional connectivity channels for receiving and transmitting information. The network device **50** may represent, for example, one or more network interface cards (NIC) or a network controller. The network device **50** may include a local area network (LAN) interface for connecting to a wired Ethernet-based network and/or a wireless LAN, such as an IEEE 802.11x wireless network. In certain embodiments, the NFC interface **44** may be used to receive information, such as the service set identifier (SSID), channel, and encryption key, used to connect to the LAN.

The network device **50** also may include a wide area network (WAN) interface that permits connection to the Internet via a cellular data network, such as the Enhanced Data rates for GMS Evolution (EDGE) network or the 3G network. The network device **50** may coordinate with one or more antennas **52** to transmit and receive radio frequency signals of a cellular

network. Further, the network device **50** may include a personal area network (PAN) interface for connecting to a Bluetooth® network, an IEEE 802.15.4 (ZigBee) network, or an ultra wideband network (UWB). The network device **50** may include any number and combination of network interfaces. As will be appreciated, the network device may employ one or more protocols, such as the High-Speed Downlink Packet Access (HSDPA) protocol, for rapidly downloading data over a network. Additionally, the network device **50** may allow the device **10** to receive a software upgrade that enables the device **10** to receive motion based inputs in accordance with certain embodiments.

In certain embodiments, the device **10** may use a device identification networking protocol to establish a connection with an external device through a network interface. For example, both the device **10** and the external device may broadcast identification information using Internet protocol (IP). The devices may then use the identification information to establish a network connection, such as a PAN connection or a LAN connection, between the devices. By way of example, the device identification protocol may be Bonjour® by Apple Inc.

Information received through the network device **50**, as well as information contained in the storage **48**, may be displayed on the display **24**. As noted above, a user may select information to display through the GUI **28** (FIG. 1). A touch screen **54** may be positioned in front of or behind the display **24** and may be used to select graphical elements, such as the icons **30** (FIG. 1), shown on the display **24**. Further, the touch screen may be used to move graphical elements shown on the display **24** to confirm a payment transaction. The touch screen **54** is configured to generate an input based on a user's or object's touch and to send the information to the CPU **46**, which interprets the touch event and performs a corresponding action. The touch screen **54** may employ any suitable type of touch screen technology such as resistive, capacitive, infrared, surface acoustic wave, electromagnetic, or near field imaging. Furthermore, the touch screen **54** may employ single point or multipoint sensing.

An input/output (I/O) controller **56** may provide the infrastructure for exchanging data between the CPU **46** and input/output devices, such as the touch screen **54** and the display **24**. The I/O controller **38** may contain one or more integrated circuits and may be integrated with the CPU **46** or exist as a separate component. The I/O controller **56** also may provide the infrastructure for communicating with external devices through the I/O ports **58**. The I/O ports **58** may include the I/O ports **34**, **36**, and **38** shown in FIG. 1 and may be used for connecting the device **10** to an external computer, a printer, audio headphones, or the like.

As noted above, a user may navigate through the GUI **28** (FIG. 1) using the input structures **60** located on external surfaces of the device **10**. The user input structures **60** may include the input structures **14**, **16**, **18**, **20**, and **22** shown in FIG. 1 and may communicate with the CPU **46** through the I/O controller **56**. The user input structures **60** may be used in conjunction with, or independently of, the touch screen **54** to select inputs for the device **10**.

In addition to receiving user input through the input structures **60** and the touch screen **54**, the device **10** may include a motion sensing device **62** for receiving user input. The motion sensing device **62** may be any device configured to measure motion or acceleration, such as an accelerometer or a gyroscope. In one embodiment, the motion sensing device **40** may be a three-axis accelerometer that includes a sensing element and an integrated circuit interface for providing the measured acceleration and/or motion data to the CPU **46**. The motion

sensing device **62** may be configured to sense and measure various types of motion including, but not limited to, velocity, acceleration, rotation, and direction.

Motion data acquired by the motion sensing device **62** may be used to confirm a payment transaction. As discussed further below, the motion sensing device **62** may be configured to sense motion of the device **10** and transmit motion data to the CPU **46** to adjust one or more graphical elements shown on the display **24**. For example, a graphical element, such as a slide bar, may be moved across the display **24** in response to sensed motion. In certain embodiments, the position of the graphical element may be used to confirm or decline a payment transaction.

The device **10** may be powered by a power source **64** that may include one or more batteries and, or alternatively, and AC power source, such as provided by an electrical outlet. In certain embodiments, the device **10** may include an integrated power source that may include one or more batteries, such as a Li-Ion battery, which may be user-removable or secured to the enclosure **12**. In certain embodiments, a proprietary connection I/O port may be used to connect the device **10** to a power source for recharging the battery.

FIG. 3 is a flowchart depicting an exemplary method **66** for confirming a payment transaction using the electronic device **10**. The method **66** may be employed to confirm payments for various types of monetary transactions including, but not limited to, purchasing goods or services from an online or brick and mortar store, paying for goods or services received in person but outside of a store (such as paying for a pizza delivery order), exchanging money between peers, and exchanging or returning previous purchases.

The method **66** may begin by receiving (block **68**) a payment selection that identifies a financial account for making or receiving a payment. The payment selection may be received through the touch screen **54** (FIG. 2) of the electronic device **10**. For example, a user may access an electronic wallet or payment service, such as Google Checkout or PayPal, through the electronic device **10** to display available payment options. The electronic wallet or payment service may store financial account information for payment instruments, such as credit cards, debit cards, pre-paid or gift cards, checking accounts, and/or savings accounts, that may be presented to a user through the electronic device **10** upon accessing the electronic wallet or payment service. In certain embodiments, the electronic wallet may be an electronic wallet in accordance with the teachings of the commonly assigned U.S. patent application Ser. No. 12/351,649, entitled "Electronic Wallet System and Method," to Brandon Casey et al., filed on the same date as the present application, the entirety of which is herein incorporated by reference for all purposes.

Further, in certain embodiments, the device may display an electronic wallet or payment service in response to receiving information through the network device **50**, the NFC device **44**, or other input structure such as a camera, or bar code reader. For example, the electronic device **10** may display a specific payment service in response to receiving information in an SMS message or reading information from an NFC tag. The received information may include a request for payment as well as information for selecting a payment service and processing a payment transaction. For example, the information may include a handler identifier that specifies a payment service, electronic wallet application, or plug-in that may be used for the payment transaction. The information also may identify suitable payment methods, such as types of credit cards, prepaid cards, and bank accounts that may be selected to complete the payment transaction. Further, the information

may include connectivity information such as supported devices, supported functionalities, and supported security protocols. In response to receiving the information, the device 10 may select and launch a payment service or electronic wallet application. In certain embodiments, the device 10 may select and launch the payment service or electronic wallet application using control logic stored within the storage 48 or CPU 46.

Upon accessing a payment service or electronic wallet, the electronic device 10 may display account information and/or virtual representations of available payment instruments through the GUI 28 (FIG. 1) of the device 10. A user may then select a payment instrument by tapping a corresponding graphical element on the touch screen 54 (FIG. 2) of the device 10. In certain embodiments, a personal identification number (PIN), password, or other type of identifier, may be associated with a payment instrument. In these embodiments, upon selection of the payment instrument, the device 10 may request (block 70) a PIN to verify the payment instrument. In certain embodiments, the device 10 may display a virtual keypad for entering the PIN through the GUI 28 of the electronic device 10.

After the PIN has been entered, the device 10 may display (block 71) a confirmation screen. Of course, in certain embodiments, a PIN may not be required and block 70 may be omitted. In these embodiments, a confirmation screen may be displayed in response to receiving (block 68) a payment selection. The confirmation screen may be part of the GUI 28 (FIG. 1) and may include a summary that describes the payment transaction by displaying information such as the price, shipping cost, tax, and/or goods or services involved in the payment transaction. The confirmation screen also may include one or more graphical elements that may be moved (such as moved laterally) by a user to confirm the payment transaction. In certain embodiments, the graphical elements may be configured to represent a virtual swipe of a credit card.

The method may continue by sensing (block 72) motion. The device 10 may sense motion through the touch screen 54 (FIG. 2) or through the motion sensing device 62 (FIG. 2). For example, a user may contact a graphical element on the touch screen 54 and slide the graphical element to a confirmation position shown on the device 10 to confirm the payment transaction. The touch screen 54 may sense motion as a user's finger or pointing object moves across the touch screen 54. The touch screen 54 also may sense motion by detecting levels of pressure exerted by a user's finger or object on the touch screen 54. In another example, the device 10 may sense motion of the electronic device 10 through the motion sensing device 62. For example, in one embodiment, a user may move the electronic device 10 to the right to confirm a payment transaction. The motion sensing device 62 may sense motion as the device 10 moves.

As the device 10 senses motion, either through the touch screen 54 or the motion sensing device 62, the device 10 may acquire motion data corresponding to the sensed motion. In certain embodiments, the motion data may represent direction, distance, velocity, and/or the location of the graphical elements, among other things. The device 10 may use the motion data to determine (block 74) whether the payment selection was confirmed. For example, the CPU 46 (FIG. 2) of the device 10 may determine whether a graphical element was moved to a certain position on the touch screen to confirm the payment selection. For example, the CPU 46 may determine whether the acquired motion data indicates a direction and distance associated with moving the graphical element to a confirm position. If the device 10 determines that the payment selection was not confirmed, the device 10 may return to

displaying available payment instruments and be ready to receive (block 68) a payment selection.

If the device 10 determines that the payment selection was confirmed, the device 10 may then confirm (block 76) the payment transaction by transmitting payment information to a merchant, payee, financial institution or service responsible for processing the payment. For example, the device 10 may transmit payment information, such as a confirmation message indicating that the payment transaction has been confirmed, to a payment service, such as PayPal. Upon receiving the confirmation message, the payment service may begin processing the payment. In another example, the confirmation message may be transmitted to the financial institution that issued the selected payment instrument. In certain embodiments, the confirmation message may be transmitted to the financial institution through the payment recipient. For example, the electronic device 10 may transmit the payment information to a store's server for subsequent transmission to the financial institution.

In addition to or instead of a confirmation message, the payment information may include other types of transaction and/or account information, such as a sender and/or recipient identifier, payment instrument identifier, account number, payment amount, remittance advice details (including, but not limited to, line item details, merchant information, date and time, tax details, and shipping costs), device location, shipping location, billing address, and/or confirmation message, to a merchant or payment recipient to enable processing of the payment transaction. For example, in an embodiment where financial account information for the selected payment instrument is stored on the electronic device 10, for example within the long-term storage 48 (FIG. 2), the device 10 may confirm the payment transaction by transmitting account information, such as the account number, to the merchant and/or to the financial institution. However, in other embodiments, a financial institution, such as a payment service, may already have the financial account information. In these embodiments, the payment information may include a unique identifier, authorization key, or encrypted message that enables the financial institution to retrieve the financial account information. To confirm the payment transaction, the payment information may be transmitted using the network device 50 (FIG. 2) or the NFC device 44 (FIG. 2). Further, as noted above, the payment information may be encrypted and/or digitally signed by the merchant's and sender's public keys.

After the payment transaction has been confirmed, the device 10 may receive and display (block 78) a receipt for the payment transaction. For example, the receipt may identify the amount tendered, the payment recipient, and the payment instrument used to complete the payment transaction. In certain embodiments, the receipt may be stored within an electronic wallet application included on the device 10.

FIGS. 4-13 further illustrate methods of confirming a payment transaction using the electronic device 10. Many of these figures illustrate various screens that a user of the electronic device 10 may encounter while confirming a payment transaction. The screens may be part of the GUI 28 (FIG. 1) and may be navigated using the touch screen 54 (FIG. 2) and/or the user input structures 14, 16, 18, 20, and 22 (FIG. 1) of the electronic device 10. As may be appreciated, the functionality described may be achieved with a wide variety of graphical elements and visual schemes. Therefore, the screens shown in the following figures are not intended to be limiting. Other embodiments may include a wide variety of user interface styles and the precise user interface conventions shown herein are provided by way of example only.

11

FIG. 4 illustrates a series of screens for creating payment transactions using the electronic device 10. A shopping application may be accessed through selection of the shopping icon 32 shown in FIG. 1 and may include a screen 80 that serves as the main menu. The screen 80 includes a title bar 82 indicating the current state of the device 10. As shown on the screen 80, the device 10 is currently running the shopping application. The screen 80 also includes several graphical elements 84, 86, and 88 that allow navigation within the shopping application. For example, the graphical element 84 may correspond to a done button that when selected may return the user to the home screen shown in FIG. 1. The user may select the button 84 to exit the shopping application.

The graphical elements 86 and 88, shown here as display windows, allow navigation through the shopping application. Each display window 86 and 88 includes selection bars 90, 92, 94, and 96 that may be selected to access different parts of the shopping application. Specifically, selection of the saved orders selection bar 90, may display a screen showing previous orders that have been made but not yet purchased. In certain embodiments, the selection bar 90 may be selected to view a saved order and confirm a payment transaction using techniques similar to those illustrated in FIG. 5. The transaction history selection bar 92 may be selected to view previous payment transactions made using the electronic device 10. In certain embodiments, payment transactions confirmed using the electronic device 10 may be stored within the long-term storage 48 (FIG. 2) and accessed through the selection bar 92.

The selection bars 94 and 96 may be selected to conduct online or in store shopping, respectively. Specifically, the online shopping selection bar 94 may be selected to access a website for conducting online shopping, while the in store shopping selection bar 96 may be selected to conduct shopping using the electronic device 10 while in a brick and mortar retail store. Each selection bar 90, 92, 94, and 96 includes arrows 98 that indicate that additional screens may be accessed by selecting the selection bars 90, 92, 94, and 96.

The screen 80 also includes a summary bar 100 displaying an icon 102 representing an electronic wallet that may be accessed through the electronic device 10. As described above with respect to FIG. 3, the electronic wallet may store financial account information for payment instruments that a user that may select to pay for shopping or other payment transactions. In certain embodiments, the financial account information may be stored on the electronic device or accessed through a third party service provider. In certain embodiments, the icon 102 may be used to access an electronic wallet application as previously described.

In response to selection of the online shopping selection bar 94, the electronic device 10 may display a screen 104 for conducting online shopping. Within the title bar 82, a graphical element 106 may be selected to return to the shopping application main screen 80. The screen 104 also includes an Internet navigation bar 108 that may be used to search for and navigate to online shopping sites using a web browser included on the electronic device 10. For example, a search term or web address may be typed into the entry area 110 and displayed by selecting a graphical element 112. A graphical element 114 may be selected to refresh the Internet page.

The screen 80 also includes a display area 116 that shows the currently entered website. A lower navigation bar 118 includes several graphical elements 120, 122, 124, and 126 for navigating within the web browser. Specifically, the graphical elements 120 may be used to navigate to previous and subsequent web pages. The graphical element 122 may be used to view and access bookmarks stored within the

12

electronic device, and the graphical element 124 may be used to access other web pages that are currently open on the electronic device 10.

The graphical element 126 may be used to create bookmarks and to add or create shopping icons 128 that may be selected to access frequently used online shopping websites. In certain embodiments, some shopping icons 128 may be preloaded onto an electronic device 10 by the device manufacturer. Indicators 130 shown below the icons 128 indicate that a user may scroll to the right or left of the lower summary bar 100 to access additional shopping icons 128.

Selection of one of the shopping icons 128 may cause the corresponding website to be displayed within the display area 116. The website may include graphical elements 132 that may be selected to navigate through the website and to select items for purchase. After all items have been selected, a user may select the graphical element 134 to access a virtual shopping cart and view items in the current order.

In response to selection of the graphical element 134, the electronic device 10 may display an order summary screen 136 detailing the items in the virtual shopping cart, as well as the item quantity and amount due, among other things. If the user is not ready to checkout, she may select a graphical element 138 to continue shopping. However, if the user is ready to checkout, the user may select a graphical element 140 to initiate a payment transaction. In certain embodiments, selection of the graphical element 140 may display subsequent screens for entering account information for a payment instrument.

The order summary screen 136 also includes a display area 142 with graphical elements 144 and 146 that may be used to select express checkout options. In certain embodiments, the express checkout options may include payment through payment service providers, such as MobilePay, available from Apple Inc., MasterCard Express Checkout, Google Checkout, or PayPal. In certain embodiments, the payment service providers may maintain a user's financial account information on an external server and a user may be required to enter login information to access her account. In addition to paying using express checkout options, a user may select the icon 102 to pay for the order using her electronic wallet.

FIG. 5 illustrates a series of screens for confirming a payment transaction. As discussed above with respect to FIG. 4, the order summary screen 136 includes the graphical elements 140, 144, 146, and 142 for initiating a payment transaction. In response to selection of one of these graphical elements, the device may display a PIN entry screen. For example, selection of the express checkout graphical element 144 may display a screen 148 for selecting a payment instrument and entering a PIN. The screen 148 includes a title bar 150 with instructions 152 directing a user to enter a PIN corresponding to a selected payment instrument, such as a credit card. The title bar 150 also includes a graphical element 154 that may be selected to return to the order summary screen 136.

A display window 156, shown on the screen 148, includes several images 158 of payment instruments that may be selected by a user to pay for the sales order. As described above, the financial account information corresponding to the payment instruments may be maintained by a payment service provider. Using the touch screen 54 (FIG. 2), a user may select an image 158 to identify a payment instrument for the sales transaction. As represented by the indicators 130, additional images 158 may be accessed by scrolling through the card images 158.

After a card image 158 has been selected, a user may enter a PIN corresponding to the selected payment instrument

13

through a keypad **160**. Keys or buttons **162** of the keypad **160** may be used to enter a PIN or password for an identified payment instrument. The keypad **160** also may include a delete key **164** for removing an existing entry. After the PIN has been entered, a user may select the enter key **166** to submit the PIN and display a confirmation screen **168**. In certain embodiments, the keypad **160** may be randomly organized to provide enhanced security during entry of the PIN. For example, in one embodiment the keypad **160** may be randomly organized in accordance with the teachings of the commonly assigned U.S. patent application Ser. No. 12/286, 313, entitled "Systems and Methods for Secure Wireless Transactions," to Michael Rosenblatt et al., filed on Sep. 30, 2008, the entirety of which is herein incorporated by reference for all purposes.

In certain embodiments, a PIN or password may not be required. In these embodiments, the keypad **160** may be omitted and selection of a card image **158** may cause the confirmation screen **168** to be displayed. Further, in certain embodiments, the organization of the keypad and/or the password and pin entry conditions may be customizable by a user. For example, a user may set the device to employ an optionally randomized keypad.

The confirmation screen **168** includes an order summary section **172** that displays details about the sales order, such as the item price, tax, and shipping costs. In certain embodiments, the order summary section **172** may be selected to display additional details about the order. The confirmation screen **168** also includes a display window **174** with a selection bar **176** displaying the shipping information for the order. In certain embodiments, the shipping information may be associated with the selected payment instrument and retrieved by the device **10**. The selection bar **176** may be selected to view further details about the shipping information and/or edit the shipping information.

The display window **174** also includes a prompt asking a user to confirm the payment transaction. In certain embodiments, the prompt may identify the amount of the transaction and the payment recipient, among other things. The confirmation screen **168** also may display an image **158** of the selected payment instrument. Instructions **178** located in the lower summary bar **100** may prompt the user to move a graphical element **180** to confirm the payment transaction. The depicted graphical element **180** includes a slide bar **182** that may be moved to the right or to the left using the touch screen **54** (FIG. 2). The slide bar **182** may slide along a track **184** between a decline position **186** and confirmation position **188**. Specifically, a user may drag the slide bar to the left to the decline position **186** to decline the payment or the user may drag the slide bar **182** to the right to the confirmation position **188** to confirm the payment transaction.

In certain embodiments, the device **10** may be configured to move the slide bar in response to detecting a specified level of pressure through the touch screen **54**. For example, the device **10** may be configured to move the slide bar in response to sensing a level of pressure that exceeds a minimum pressure level stored within the device **10** or that falls within a range of pressure levels stored within the device **10**. In certain embodiments, the minimum pressure level or range of pressure levels may be customizable by a user to provide additional safeguards against inadvertent payment confirmations.

In certain embodiments, the graphical element **180** and associated motion based input by the user may operate together to provide a motion based confirmation for a payment transaction. The motion based confirmation is intended to provide a verification step that may reduce inadvertent payment confirmations. Further, the motion based confirma-

14

tion may impress upon a user the significance of the payment transaction. Of course, in other embodiments, the graphical elements **180** and **184** may represent different symbols and shapes arranged in various configurations. For example, the graphical element **184** may be replaced by arrows instructing a user to move the graphical element **182** in a vertical or diagonal direction or along a curve. Further, the graphical elements **182** and **184**, the decline position **186**, and the confirmation position **188**, may be located in different areas of the confirmation screen **168**.

The graphical element **182** may move across the confirmation screen **168** when the graphical element **182** is dragged by a user using the touch screen **54**. For example, a user may use her finger **190**, or another object, to move the graphical element **182** from a center position **192** to the confirmation position **188**. In response to, or contemporaneously with, the movement, the device **10** may display a message **193** indicating that the payment has been confirmed. When the graphical element **182** reaches the confirmation position **188**, the device **10** may transmit payment information to confirm the payment transaction. As described above with respect to FIG. 3, the payment information may include a confirmation message, financial account information, an account identifier, a device identifier, or combinations thereof.

After confirming the payment transaction, the device **10** may display a receipt screen **194**. The receipt screen **194** may include an electronic receipt for the payment transaction that may describe the items purchased, the amount tendered, the payment instrument, and other information related to the payment transaction. The receipt screen **194** also may include a graphical element **196** that may be selected to email the electronic receipt to an email account. In other embodiments, the electronic receipt may be stored within an electronic wallet. From the receipt screen **194**, a graphical element **198** may be selected to return to the shopping application main menu **80** (FIG. 4) to continue shopping.

FIG. 6 illustrates a series of screen for declining a payment transaction using the electronic device **10**. As described above with respect to FIG. 5, the confirmation screen **168** may be displayed after selection of the payment instrument represented by the image **158**. From the confirmation screen **168**, a user may drag the slide bar **182** to the left from the center position **190** to the decline position **186**. In response to, or contemporaneously with, the movement, the device **10** may display a message **199** indicating that the payment has been declined. After the payment has been declined, the device may display the payment selection screen **148** to allow a user to select another payment instrument to complete a payment transaction.

FIG. 7 illustrates a series of screens for creating a payment transaction while shopping in a store. From the shopping application main menu **80**, a user may select the in-store shopping selection bar **96** to cause the device to display an in-store shopping screen **200**. A graphical element **106** may be selected to return to the main menu **80**. The screen **200** may display available networks that may be used to conduct shopping at a retail store. In certain embodiments, the available networks may represent LANs maintained by retail stores that may be detectable by the device **10** when the device **10** is in close proximity to the retail stores. The available networks may be shown within one or more display windows **202**. As shown, the device **10** has detected a network for an Apple Store®. The display window **202** may be selected to connect to the network and begin shopping at the Apple Store®.

Upon selection of the display window **202**, the device **10** may connect to the network, for example through the network device **50** (FIG. 2), and display an in-store shopping screen

15

204. In certain embodiments, the in-store shopping screen 204 may be part of an in-store shopping application provided by the store. The screen 204 includes instructions 206 that prompt a user to select items for purchase. A user may return to the shopping main menu by selecting graphical element 106.

The screen 204 includes several graphical elements 208 that may be selected to navigate within the site and select items for purchase. After a user is finished selecting items, the user may select a graphical element 210 to view the order summary screen 136. As described above with respect to FIG. 4, the order summary screen 136 may describe the items in the order, as well as the item quantity and amount due. From the order summary screen 136, the user may select a graphical element 102, 140, 144, or 146 to initiate the payment transaction. For example, a user may select the graphical element 144 to display the selection screen 148. From the screen 148, a user may select a payment instrument for the payment transaction and enter a PIN if required. Depending on the type of checkout method selected, the screen 148 may include various configurations, graphical elements, and keypads for selecting payment instruments and entering PINS or other verification codes.

FIG. 8 illustrates a series of screens for confirming a payment transaction in an in-store shopping context. The payment confirmation process may be generally similar to the payment confirmation process used in the online shopping context described above with respect to FIGS. 4-5. From the selection screen 148, a user may select an image 158 of a payment instrument and enter a corresponding PIN, if required. After entry of the PIN, the device 10 may display a confirmation screen 212. The confirmation screen may include an image 158 of the selected payment instrument, as well as the order summary 178 describing the order. The confirmation screen 212 also may include a display window 214 further describing details of the order, such as the pickup method and the name of the customer. In certain embodiments, the display window 214 may be selected to enter or edit pickup details. For example, a user may wish to be notified via email, text message, or cellular telephone when the order is available for pickup. In other embodiments, a user may schedule pickup at a designated time or have certain items shipped to the user's home.

The confirmation screen 212 also includes a prompt 216 asking a user to confirm the payment transaction. The lower summary bar 100 includes graphical elements 218, 220, and 222 that may be used to confirm the payment. Specifically, the graphical element 218 represents a credit card terminal, and the graphical element 220 represents a payment instrument, such as a credit card, selected by the user for payment. The graphical element 222 indicates the direction of movement required to confirm the payment. Together, the graphical elements 218, 220, and 222 may represent a virtual credit card swipe. Specifically, a user may move the image of the payment instrument 220 to the image of the credit card terminal 218 to confirm the payment transaction. If the user does not wish to confirm the transaction, the user may select the graphical element 170 within the title bar 82 to return to the selection screen 148.

If the user confirms the transaction by moving the graphical element 220 to the graphical element 218, the device 10 may display a screen 223 that includes a message 224 indicating that the virtual credit card swipe was completed successfully. The lower summary bar 100 also may show the image of the credit card 220 as having passed through the image of the credit card terminal 218. Of course, in other embodiments, the graphical elements 220 and 218 may take on various

16

forms to represent other types of payment instruments and credit card terminals or point of purchase terminals.

After the swipe is complete, the device 10 may transmit payment information to confirm the payment transaction as described above with respect to FIG. 3. The device 10 may then display a receipt screen 226 showing an electronic receipt for the payment transaction. The graphical element 196 may be selected to email the receipt to an email address. The receipt screen 226 also includes graphical elements 228 and 230 within the lower summary bar 100. Specifically, the graphical element 228 may notify a user when an order is ready to be picked up. For example, the graphical element 228 may be displayed on the screen in response receiving a notification message from the store indicating that the order is ready for pickup. In certain embodiments, the graphical element 228 also may specify the pickup location. In certain embodiments, the graphical element 230 may be selected to display a map of the store showing the pickup location. Of course, various other graphical elements and icons may be included within the receipt screen 226.

FIG. 9 illustrates a close range connection 232 that may be used to initiate and/or complete a payment transaction. The close range connection 232 may include a PAN connection, an RFID connection, an NFC network connection, wireless Internet connection, or other suitable type of close range communication. In certain embodiments, the connection may be established using a device identification networking protocol, such as Bonjour®. The connection may be used to transfer information, such as sales order information and payment information, between the device 10 and another electronic device 234. The close range connection 232 may be established when a user 236 of the electronic device 10 brings the electronic device 10 in close proximity to the other electronic device 234 which may be operated by another user 234 or may operate automatically.

The electronic device 234 may include a handheld portable electronic device, such as a portable media player or personal data organizer, or may include a point of sale or purchase terminal, a vending machine or kiosk, or other suitable payment receiving device. In certain embodiments, the electronic device 234 may be a portable point of purchase device for conducting a sales transaction in accordance with the teachings of the commonly assigned U.S. patent application Ser. No. 12/286,445, entitled "Portable Point of Purchase Devices and Methods," to Gloria Lin et al., filed on Sep. 30, 2008, the entirety of which is herein incorporated by reference for all purposes. In other embodiments, the electronic device 234 may be a handheld electronic device for conducting peer-to-peer financial exchanges in accordance with the teachings of the commonly assigned U.S. patent application Ser. No. 12/286,488, entitled "Peer-to-Peer Financial Transaction Devices and Methods," to Gloria Lin et al., filed on Sep. 30, 2008, the entirety of which is herein incorporated by reference for all purposes. In yet other embodiments, the electronic device 234 may include an electronic kiosk connected to a retail server. In these embodiments, the user 236 of the electronic device 10 may operate both the electronic device 10 and the electronic kiosk, which may not require the presence of the user 238.

FIG. 10 illustrates a series of screens for confirming a payment transaction through an electronic wallet application. In certain embodiments, the device 10 may display the electronic wallet application in response to sensing a close range communication 232 with another electronic device 234 as illustrated in FIG. 9. The device 10 also may display the electronic wallet application in response to receiving information related to a payment transaction, such as a sales order,

17

from another electronic device, such as the device **234** shown in FIG. **9**. In other embodiments, the electronic wallet application may be accessed by selection of the icon **102** (FIG. **4**).

Upon opening, the electronic wallet application may display a selection screen **240** that may be used to select a payment instrument for a financial transaction. The selection screen **240** may include the images **158** of payment instruments accessible through the electronic wallet. After a payment instrument has been selected and a PIN has been entered, if required, the device **10** may display a confirmation screen **242**. The screen **242** may include a graphical element **244** that can be selected to return to the selection screen **240**. The screen also may include an order summary **245** and an image **158** of the selected payment instrument.

The confirmation screen also includes the graphical element **180** that may be used to confirm the payment. As described previously with respect to FIG. **5**, a user may drag the slide bar **182** to the confirmation position **188** to confirm the payment. In one embodiment, after the payment has been confirmed, the device **10** may display a window **246** on the confirmation screen **242** prompting the user to bring the device **10** in close proximity to or contact with the other electronic device **234** (FIG. **9**) (such as by tapping the devices together) to complete the transaction. For example, in one embodiment, when the user taps the device **10** to the other electronic device **234**, the device **10** may transfer payment information to the other electronic device **234** to confirm the payment transaction over the close range connection **232**. The electronic device **234** may then subsequently transmit the payment information to the financial institution responsible for processing the payment. Further, during the tap, the devices **10** and **234** may exchange information, such as a service set identifier (SSID), channel, and encryption key, for establishing a longer range connection, such as WLAN connection or a WAN connection. The payment information may then be transferred to the electronic device **234** over the longer range connection that was established using the close range connection **232**. In other embodiments, the payment information may be transferred over the longer range connection directly to the financial institution. After the information has been transferred, a receipt screen **248** may be displayed that summarizes the order for the user.

FIG. **11** illustrates a series of screens that may be used to confirm a payment transaction during a peer-to-peer financial transaction. The peer-to-peer transaction may occur over a close range connection such as the connection **232** illustrated in FIG. **9**. In certain embodiments, the device **10** may display a peer-to-peer transaction screen **250** in response to sensing a certain close range connection. The transaction screen **250** also may be accessed through a menu of the electronic device **10**.

The transaction screen **250** includes a graphical element **252** that may be selected to return to the main menu of the electronic device shown in FIG. **1**. The screen **250** also includes images **158** of payment instruments that may be selected for payment transactions. The payment instruments may represent credit cards, debit cards, check, and bank accounts, as well as other payment forms. As noted above, the indicators **130** may notify a user that additional cards may be viewed by scrolling thorough the images **158** using the touch screen **54** (FIG. **2**). After a payment instrument is selected, a user may enter a payment amount within an entry area **254**. For example, as shown, the user has entered the amount of \$15.00 for payment to another person. The screen **250** also includes a lower summary bar with instructions **256** prompting the user to tap the receiving device. During the tap, the information may be transferred over a close range connection

18

232 (FIG. **9**), such as an RFID connection, NFC connection, or other close range connection.

After the tap, the device may display a confirmation screen **258**. The screen **258** includes an image **158** of the selected payment instrument and a display area **250** prompting the user to confirm that the payment. The display area **250** may display the payment amount, the identity of the payment recipient, and other information describing the payment transaction. In certain embodiments, the device **10** may receive information corresponding to the identity of the payment recipient over the close range connection **232** (FIG. **9**). The confirmation screen also includes a lower summary bar **100** that includes the confirmation graphical element **180**. As described above with respect to FIGS. **4** and **5**, a user may drag the slide bar **182** toward the confirmation position **188** to confirm the payment. If the user does not wish to confirm the payment, the user may drag the slide bar **182** toward the decline position **186** to decline the payment.

Of course, the payment transactions illustrated with respect to FIGS. **9-11** may be confirmed using other types of graphical elements and motion configurations. For example, the graphical elements **218**, **220**, and **222** shown in FIG. **8** may be used to confirm peer-to-peer payment transactions and/or electronic wallet payment transactions. Further, the relative sizes and shapes of the graphical elements **10**, **182**, and **184** may vary or may be configured by the user, and the respective locations of the confirmation position **188** and decline position **186** may change to provide other movements and directions for confirming the payment transaction.

In addition to confirming a payment transaction by motion sensed through the touch screen **54**, a payment transaction also may be confirmed by motion sensed through the motion sensing device **62** (FIG. **2**) as illustrated in FIGS. **12** and **13**. The payment transaction confirmations illustrated in FIGS. **12** and **13** may be employed in various payment transaction contexts including, but not limited to, online shopping, in-store shopping, electronic wallet transactions, and peer-to-peer transactions.

FIG. **12** illustrates movement of the device **10** to confirm a payment transaction. The device **10** is depicted as having moved from an original position **262** to a new position **264**. For the sake of clarity, the screen of the device **10** in the original position **262** is shown in solid lines. The payment confirmation screen **168** may be displayed when the device is in the original position **262**. The user may then move the device **10** itself to the right, as indicated by the arrows **266**, to move the slide bar **182** to the confirmation position **188**. In certain embodiments, the motion sensing device **62** (FIG. **2**) within the electronic device **10** may sense the motion of the device **10** to acquire motion data. Using the motion data, the CPU **46** may move the slide bar **182** contemporaneously with the motion of the device **10**. In this manner, a user may be able to move the slide bar **182** along the track **184** to the confirmation position **188** without touching the touch screen **54** or other input structure. When the slide bar **182** reaches the confirmation position **188**, the device **10** may transmit payment information to confirm the payment transaction.

FIG. **13** illustrates movement of the device **10** to decline a payment transaction. As shown by the arrows **272**, a user has moved the device **10** to the left from an original position **268** to a new position **270**. As noted above, the motion sensing device **62** (FIG. **2**) may sense the motion of the device **10** and the CPU **46** (FIG. **2**) may use the acquired motion data to contemporaneously move the slide bar **182** with the motion of the device **10**. When the slide bar **182** reaches the decline position **186**, the device **10** may display the message **199** indicating that the payment has been declined.

19

Of course, the right and left motions illustrated by the graphical elements in FIGS. 4-13 are provided by way of example only and are not intended to be limiting. In other embodiments, the motion sensing device 62 (FIG. 2) and/or the touch screen 54 (FIG. 2) may sense other directional movements to move one or more graphical elements to a confirmation position. For example, the motion sensing device 62 may sense other horizontal movements, vertical movements, rotations, and/or tilts to move a graphical element to a confirmation position or decline position.

While the invention may be susceptible to various modifications and alternative forms, specific embodiments have been shown by way of example in the drawings and have been described in detail herein. However, it should be understood that the invention is not intended to be limited to the particular forms disclosed. Rather, the invention is to cover all modifications, equivalents, and alternatives falling within the spirit and scope of the invention as defined by the following appended claims.

What is claimed is:

1. A method comprising an electronic device performing the following steps:

- receiving a user input selecting a payment instrument;
- displaying a confirmation screen for receiving a motion based input to confirm a payment with the selected payment instrument, wherein the confirmation screen comprises a graphical element moveable between an initial position and a payment confirmation position, wherein the graphical element comprises an image of a credit card, and wherein the payment confirmation position comprises an image of a credit card terminal;
- acquiring motion data corresponding to the motion based input, wherein the motion data represents movement of the graphical element from an initial position to the payment confirmation position; and
- confirming, via a processor of the electronic device, the payment with the selected payment instrument in response to the acquired motion data.

2. The method of claim 1, wherein acquiring motion data comprises sensing a direction of motion through a touch screen or sensing levels of pressure applied through the touch screen.

20

3. The method of claim 1, wherein acquiring motion data comprises sensing motion of the electronic device through a one, two, or three axis accelerometer.

4. The method of claim 1, wherein confirming the payment comprises transmitting at least one of a payment confirmation message, an account number, a sender identifier, a recipient identifier, a payment instrument identifier, remittance advice details, or an authorization key to a financial institution to process a payment transaction.

5. The method of claim 1, comprising contemporaneously varying the graphical element displayed on the confirmation screen based on the acquired motion data.

6. A method comprising an electronic device performing the following steps:

- receiving a user input selecting a payment instrument;
- displaying a confirmation screen for confirming a payment with the selected payment instrument, wherein the confirmation screen comprises an image of a credit card that can be swiped from an initial position towards an image of a credit card terminal to confirm the payment using the selected payment instrument;
- detecting movement of the image of the credit card from the initial position towards the image of the credit card terminal;
- confirming, via a processor of the electronic device, the payment with the selected payment instrument based on the movement of the image of the credit card; and
- transmitting payment information to a financial institution to process the payment transaction in response to confirming the selected payment instrument.

7. The method of claim 6, wherein detecting movement of the image of the credit card comprises detecting movement through a touch screen of the electronic device.

8. The method of claim 6, comprising detecting movement of the electronic device through a one, two, or three axis accelerometer, and contemporaneously varying the image of the credit card based on the detected movement of the electronic device.

* * * * *