

3GPP TS 36.305 V9.0.0 (2009-09)

Technical Specification

**3rd Generation Partnership Project;
Technical Specification Group Radio Access Network;
Evolved Universal Terrestrial Radio Access Network
(E-UTRAN);
Stage 2 functional specification of
User Equipment (UE) positioning in E-UTRAN
(Release 9)**



<p>EX. 2003 Samsung v KPN IPR2025-00503</p>
--

The present document has been developed within the 3rd Generation Partnership Project (3GPP™) and may be further elaborated for the purposes of 3GPP. The present document has not been subject to any approval process by the 3GPP Organizational Partners and shall not be implemented. This Specification is provided for future development work within 3GPP only. The Organizational Partners accept no liability for any use of this Specification. Specifications and reports for implementation of the 3GPP™ system should be obtained via the 3GPP Organizational Partners' Publications Offices.

Keywords

LTE, location, stage 2

3GPP

Postal address

3GPP support office address

650 Route des Lucioles - Sophia Antipolis
Valbonne - FRANCE
Tel.: +33 4 92 94 42 00 Fax: +33 4 93 65 47 16

Internet

<http://www.3gpp.org>

Copyright Notification

No part may be reproduced except as authorized by written permission.
The copyright and the foregoing restriction extend to reproduction in all media.

© 2009, 3GPP Organizational Partners (ARIB, ATIS, CCSA, ETSI, TTA, TTC).
All rights reserved.

UMTS™ is a Trade Mark of ETSI registered for the benefit of its members
3GPP™ is a Trade Mark of ETSI registered for the benefit of its Members and of the 3GPP Organizational Partners
LTE™ is a Trade Mark of ETSI currently being registered for the benefit of its Members and of the 3GPP Organizational Partners
GSM® and the GSM logo are registered and owned by the GSM Association

Contents

Foreword	6
1 Scope	7
2 References	7
3 Definitions and abbreviations.....	8
3.1 Definitions	8
3.2 Abbreviations.....	8
4 Main concepts and requirements	9
4.1 Assumptions and Generalities.....	9
4.2 Role of UE Positioning Methods	10
4.3 Standard UE Positioning Methods.....	10
4.3.1 Network-assisted GNSS Methods	11
4.3.2 Downlink positioning.....	11
4.3.3 Enhanced Cell ID Methods	11
5 E-UTRAN UE Positioning Architecture.....	11
5.1 UE Positioning Operations	12
5.2 E-UTRAN Positioning Operations	14
5.2.1 Downlink Position Method Support (FFS).....	14
5.3 Functional Description of Elements Related to UE Positioning in E-UTRAN.....	15
5.3.1 User Equipment (UE).....	15
5.3.2 Node B	15
5.3.3 Evolved Serving Mobile Location Centre (E-SMLC).....	15
5.3.4 Location Measurement Unit (LMU)	16
6 Signalling protocols and interfaces	16
6.1 Network interfaces supporting positioning operations.....	16
6.1.1 General LCS control plane architecture	16
6.1.2 LTE-Uu interface	16
6.1.3 S1-MME interface.....	16
6.1.4 SLs interface	16
6.2 UE-terminated protocols.....	16
6.2.1 LTE Positioning Protocol (LPP)	16
6.2.2 Radio Resource Control (RRC).....	17
6.3 eNB-terminated protocols	17
6.3.1 LTE Positioning Protocol Annex (LPPa).....	17
6.3.2 S1 Application Protocol (S1-AP).....	17
6.4 Signalling between an E-SMLC and UE	17
6.4.1 Protocol Layering.....	17
6.4.2 LPP PDU Transfer	18
6.5 Signalling between an E-SMLC and eNode B.....	19
6.5.1 Protocol Layering.....	19
6.5.2 LPPa PDU Transfer for UE Positioning.....	19
6.5.3 LPPa PDU Transfer for Positioning Support	20
7 General E-UTRAN UE Positioning procedures.....	21
7.1 General LPP procedures for UE Positioning	21
7.1.1 LPP Procedures	21
7.1.2 Positioning procedure types	22
7.1.2.1 Capability exchange	22
7.1.2.2 Assistance data transfer	22
7.1.2.3 Location information transfer	23
7.1.2.4 Multiple procedures.....	24
7.1.2.5 Sequence of Procedures.....	24
7.2 General LPPa Procedures for UE Positioning	25
7.2.1 LPPa Procedures	25
7.2.2 LPPa procedure types.....	25

7.2.2.1	Location information transfer	25
7.3	Service Layer Support using combined LPP and LPPa Procedures	26
7.3.1	NI-LR and MT-LR Service Support	26
7.3.2	MO-LR Service Support	27
8	Positioning methods and Supporting Procedures	28
8.1	GNSS positioning methods	28
8.1.1	General	28
8.1.2	Information to be transferred between E-UTRAN Elements	29
8.1.2.1	Information that may be transferred from the E-SMLC to UE	29
8.1.2.1.1	Reference Time	30
8.1.2.1.2	Reference Location	30
8.1.2.1.3	Ionospheric Models	30
8.1.2.1.4	Earth Orientation Parameters	30
8.1.2.1.5	GNSS-GNSS Time Offsets	30
8.1.2.1.6	Differential GNSS Corrections	30
8.1.2.1.7	Ephemeris and Clock Models	30
8.1.2.1.8	Real-Time Integrity	30
8.1.2.1.9	Data Bit Assistance	30
8.1.2.1.10	Acquisition Assistance	31
8.1.2.1.11	Almanac	31
8.1.2.1.12	UTC Models	31
8.1.2.2	Information that may be transferred from the UE to E-SMLC	31
8.1.2.2.1	GNSS Measurement Information	31
8.1.2.2.1.1	UE-based mode	31
8.1.2.2.1.2	UE-assisted mode	32
8.1.2.2.2	Additional Non-GNSS Related Information	32
8.1.3	Assisted-GNSS Positioning Procedures	32
8.1.3.1	Position Capability Transfer Procedure	32
8.1.3.1.1	E-SMLC-initiated (UE to E-SMLC) Position Capability Transfer	32
8.1.3.2	Assistance Data Delivery Procedure	33
8.1.3.2.1	E-SMLC initiated Assistance Data Delivery	33
8.1.3.2.2	UE initiated Assistance Data Delivery	33
8.1.3.3	Position Measurement Procedure	34
8.1.3.3.1	E-SMLC initiated Position Measurement	34
8.1.3.3.2	UE-initiated Position Measurement	34
8.2	Downlink positioning method	35
8.2.1	General	35
8.2.2	Information to be transferred between E-UTRAN Elements	35
8.2.2.1	Assistance Data that may be transferred from the E-SMLC to UE	35
8.2.2.2	Assistance Data that may be transferred from the eNode B to E-SMLC	35
8.2.2.3	Location Information that may be transferred from the UE to E-SMLC	36
8.2.3	Downlink Positioning Procedures	36
8.2.3.1	Position Capability Transfer Procedure	36
8.2.3.1.1	E-SMLC-initiated Position Capability Transfer	36
8.2.3.2	Assistance Data Delivery Procedure	36
8.2.3.2.1	Assistance Data Delivery between E-SMLC and UE	36
8.2.3.2.1.1	E-SMLC-initiated assistance data delivery to the UE	37
8.2.3.2.1.2	UE-initiated assistance data delivery to the UE	37
8.2.3.2.2	Assistance Data Delivery between E-SMLC and eNode B	37
8.2.3.2.2.1	eNode B-initiated assistance data delivery to the E-SMLC	38
8.2.3.2.2.2	E-SMLC-initiated assistance data delivery to the E-SMLC	38
8.2.3.3	Position Measurement Procedure	38
8.2.3.3.1	E-SMLC-initiated Position Measurement	38
8.2.3.3.2	UE-initiated Position Measurement	39
8.3	Enhanced cell ID positioning methods	39
8.3.1	General	39
8.3.2	Information to be transferred between E-UTRAN Elements	40
8.3.2.1	Information that may be transferred from the E-SMLC to UE	40
8.3.2.2	Information that may be transferred from the UE to E-SMLC	40
8.3.2.3	Information that may be transferred from the eNB to E-SMLC	40
8.3.3	Downlink E-CID Positioning Procedures	41

8.3.3.1	Position Capability Transfer Procedure	41
8.3.3.1.1	E-SMLC-initiated (UE to E-SMLC) Position Capability Transfer	41
8.3.3.2	Assistance Data Delivery Procedure	41
8.3.3.3	Position Measurement Procedure	41
8.3.3.3.1	E-SMLC-initiated Position Measurement	41
8.3.3.3.2	UE-initiated Position Measurement	42
8.3.4	Uplink E-CID Positioning Procedures	42
8.3.4.1	Position Capability Transfer Procedure	43
8.3.4.2	Assistance Data Delivery Procedure	43
8.3.4.3	Position Measurement Procedure	43
8.3.4.3.1	E-SMLC-initiated Position Measurement	43
8.4	Downlink Supporting Procedures	43
8.4.1	General	44
8.4.2	Location Related Information	44
8.4.3	Location Related Information Acquisition Procedure	44
8.4.3.1	On Demand Procedure	44
8.4.3.2	Triggered Procedure	44
Annex A (informative): Definitions and Terms		46
Annex B (informative): Use of LPP with SUPL		47
B.1	SUPL 2.0 Positioning Methods and Positioning Protocols	47
B.2	SUPL 2.0 and LTE Architecture	48
B.3	LPP session procedures using SUPL	49
B.4	Procedures combining C-plane and U-plane operations	50
Annex C (informative): Change history		52

Foreword

This Technical Specification has been produced by the 3rd Generation Partnership Project (3GPP).

The contents of the present document are subject to continuing work within the TSG and may change following formal TSG approval. Should the TSG modify the contents of the present document, it will be re-released by the TSG with an identifying change of release date and an increase in version number as follows:

Version x.y.z

where:

- x the first digit:
 - 1 presented to TSG for information;
 - 2 presented to TSG for approval;
 - 3 or greater indicates TSG approved document under change control.
- y the second digit is incremented for all changes of substance, i.e. technical enhancements, corrections, updates, etc.
- z the third digit is incremented when editorial only changes have been incorporated in the document.

1 Scope

The present document specifies the stage 2 of the UE Positioning function of E-UTRAN, which provides the mechanisms to support or assist the calculation of the geographical position of a UE. UE position knowledge can be used, for example, in support of Radio Resource Management functions, as well as location-based services for operators, subscribers, and third-party service providers. The purpose of this stage 2 specification is to define the E-UTRAN UE Positioning architecture, functional entities and operations to support positioning methods. This description is confined to the E-UTRAN Access Stratum. It does not define or describe how the results of the UE position calculation can be utilised in the Core Network (e.g., LCS) or in E-UTRAN (e.g., RRM).

UE Positioning may be considered as a network-provided enabling technology consisting of standardised service capabilities that enable the provision of location applications. The application(s) may be service provider specific. The description of the numerous and varied possible location applications which are enabled by this technology is outside the scope of the present document. However, clarifying examples of how the functionality being described may be used to provide specific location services may be included.

This stage 2 specification covers the E-UTRAN positioning methods, state descriptions, and message flows to support UE Positioning.

2 References

The following documents contain provisions which, through reference in this text, constitute provisions of the present document.

- References are either specific (identified by date of publication, edition number, version number, etc.) or non-specific.
- For a specific reference, subsequent revisions do not apply.
- For a non-specific reference, the latest version applies. In the case of a reference to a 3GPP document (including a GSM document), a non-specific reference implicitly refers to the latest version of that document *in the same Release as the present document*.

- [1] 3GPP TR 21.905: "Vocabulary for 3GPP Specifications".
- [2] 3GPP TS 23.271: "Functional stage 2 description of Location Services (LCS)"
- [3] 3GPP TS 22.071: "Location Services (LCS); Service description, Stage 1".
- [4] 3GPP TS 23.032: "Universal Geographical Area Description (GAD)".
- [5] 3GPP TS 36.306: "Evolved Universal Terrestrial Radio Access (E-UTRA); "User Equipment (UE) radio access capabilities".
- [6] IS-GPS-200, Revision D, Navstar GPS Space Segment/Navigation User Interfaces, March 7th, 2006.
- [7] IS-GPS-705, Navstar GPS Space Segment/User Segment L5 Interfaces, September 22, 2005.
- [8] IS-GPS-800, Navstar GPS Space Segment/User Segment L1C Interfaces, September 4, 2008.
- [9] Galileo OS Signal in Space ICD (OS SIS ICD), Draft 0, Galileo Joint Undertaking, May 23rd, 2006.
- [10] Global Navigation Satellite System GLONASS Interface Control Document, Version 5, 2002.
- [11] IS-QZSS, Quasi Zenith Satellite System Navigation Service Interface Specifications for QZSS, Ver.1.0, June 17, 2008.
- [12] Specification for the Wide Area Augmentation System (WAAS), US Department of Transportation, Federal Aviation Administration, DTFA01-96-C-00025, 2001.

- [13] RTCM 10402.3, RTCM Recommended Standards for Differential GNSS Service (v.2.3), August 20, 2001.
- [14] 3GPP TS 36.331: "Evolved Universal Terrestrial Radio Access (E-UTRA); "Radio Resource Control (RRC); Protocol specification".
- [15] 3GPP TS 25.331: " Radio Resource Control (RRC); Protocol Specification".
- [16] 3GPP TS 44.031: "Location Services (LCS); Mobile Station (MS) - Serving Mobile Location Centre (SMLC) Radio Resource LCS Protocol (RRLP)".
- [17] OMA-AD-SUPL-V2_0: "Secure User Plane Location Architecture Draft Version 2.0".
- [18] OMA-TS-ULP-V2_0: "UserPlane Location Protocol Draft Version 2.0".
- [19] 3GPP TS 23.401: "General Packet Radio Service (GPRS) enhancements for Evolved Universal Terrestrial Radio Access Network (E-UTRAN) access".
- [20] 3GPP TS 36.214: " Evolved Universal Terrestrial Radio Access (E-UTRA); " Physical layer – Measurements".
- [21] 3GPP TS 36.302: "Evolved Universal Terrestrial Radio Access (E-UTRA); "Services provided by the physical layer ".
- [22] 3GPP TS 25.305: "Stage 2 functional specification of User Equipment (UE) positioning in UTRAN"
- [23] 3GPP TS 43.059: "Functional stage 2 description of Location Services in GERAN"
- [24] 3GPP TR 23.891: Evaluation of LCS Control Plane Solutions for EPS

3 Definitions and abbreviations

3.1 Definitions

For the purposes of the present document, the terms and definitions given in [1] apply.

As used in this document, the suffixes “-based” and “-assisted” refer respectively to the node that is responsible for making the positioning calculation (and which may also provide measurements) and a node that provides measurements (but which does not make the positioning calculation). Thus, an operation in which measurements are provided by the UE to the E-SMLC to be used in the computation of a position estimate is described as “UE-assisted” (and could also be called “E-SMLC-based”), while one in which the UE computes its own position is described as “UE-based”.

3.2 Abbreviations

For the purposes of the present document, the following abbreviations apply.

AoA	Angle of Arrival
CID	Cell-ID (positioning method)
E-SMLC	Enhanced Serving Mobile Location Centre
E-CID	Enhanced Cell-ID (positioning method)
ECEF	Earth-Centered, Earth-Fixed
ECI	Earth-Centered-Inertial
EGNOS	European Geostationary Navigation Overlay Service
E-UTRAN	Enhanced Universal Terrestrial Radio Access Network
GAGAN	GPS Aided Geo Augmented Navigation
GLONASS	GLOBAL'naya NAVigatsionnaya Sputnikovaya Sistema (Engl.: Global Navigation Satellite System)
GMLC	Gateway Mobile Location Center
GNSS	Global Navigation Satellite System
GPS	Global Positioning System
LCS	LoCation Services

LCS-AP	LCS Application Protocol
LMU	Location Measurement Unit
LPP	LTE Positioning Protocol
LPPa	LTE Positioning Protocol Annex
MO-LR	Mobile Originated Location Request
MT-LR	Mobile Terminated Location Request
NI-LR	Network Induced Location Request
PDU	Protocol Data Unit
PRS	Positioning Reference Signal
QZSS	Quasi-Zenith Satellite System
RRM	Radio Resource Management
SBAS	Space Based Augmentation System
SET	SUPL Enabled Terminal
SLP	SUPL Location Platform
SUPL	Secure User Plane Location
T _{ADV}	Timing Advance
UE	User Equipment
WAAS	Wide Area Augmentation System
WGS-84	World Geodetic System 1984

4 Main concepts and requirements

4.1 Assumptions and Generalities

The stage 1 description of LCS at the service level is provided in [3]; the stage 2 LCS functional description, including the LCS system architecture and message flows, is provided in [2].

Positioning functionality provides a means to determine the geographic position and/or velocity of the UE based on measuring radio signals. The position information may be requested by and reported to a client (e.g., an application) associated with the UE, or by a client within or attached to the core network. The position information shall be reported in standard formats, such as those for cell-based or geographical co-ordinates, together with the estimated errors (uncertainty) of the position and velocity of the UE and, if available, the positioning method (or the list of the methods) used to obtain the position estimate.

Restrictions on the geographic shape encoded within the 'position information' parameter may exist for certain LCS client types. The EPS, including E-UTRAN, shall comply with any shape restrictions defined in LTE and, in a particular country, with any shape restrictions defined for a specific LCS client type in relevant national standards. For example, in the US, national standard J-STD-036-B restricts the geographic shape for an emergency services LCS client to minimally either an "ellipsoid point" or an "ellipsoid point with uncertainty circle and confidence" as defined in [4].

It shall be possible for the majority of the UEs (active or inactive) within a network to use the LCS feature without compromising the radio transmission or signalling capabilities of the E-UTRAN.

The uncertainty of the position measurement shall be network-implementation-dependent, at the choice of the network operator. The uncertainty may vary between networks as well as from one area within a network to another. The uncertainty may be hundreds of metres in some areas and only a few metres in others. In the event that a particular position measurement is provided through a UE-assisted process, the uncertainty may also depend on the capabilities of the UE. In some jurisdictions, there is a regulatory requirement for location service accuracy that is part of an emergency service. Further details of the accuracy requirements can be found in [3].

The uncertainty of the position information is dependent on the method used, the position of the UE within the coverage area and the activity of the UE. Several design options of the E-UTRAN system (e.g., size of cell, adaptive antenna technique, pathloss estimation, timing accuracy, eNode B surveys) shall allow the network operator to choose a suitable and cost-effective UE positioning method for their market.

There are many different possible uses for the positioning information. The positioning functions may be used internally by the EPS, by value-added network services, by the UE itself or through the network, and by "third party" services. The feature may also be used by an emergency service (which may be mandated or "value-added"), but the location service is not exclusively for emergencies.

The E-UTRAN is a new radio system design without a pre-existing deployment of “legacy” UEs operating according to the radio interface. This freedom from legacy equipment enables the location service feature design to make use of appropriate techniques to provide the most accurate results. The technique must also be a cost-effective total solution, must allow evolution to meet evolving service requirements, and must be able to take advantage of advances in technology over the lifetime of E-UTRAN deployments.

Design of the E-UTRAN positioning capability as documented in this specification includes position methods, protocols and procedures that are either adapted from capabilities already supported for UTRAN and GERAN, or created separately from first principles. The proportion of the latter is higher than if the UTRAN and GERAN capabilities had been designed to provide forward compatibility to other access types. In contrast to GERAN and UTRAN, the E-UTRAN positioning capabilities are intended to be forward compatible to other access types and other position methods, in an effort to reduce the amount of additional positioning support needed in the future. This goal also extends to user plane location solutions such as OMA SUPL ([17], [18]), for which E-UTRAN positioning capabilities are intended to be compatible where appropriate.

As a basis for the operation of UE Positioning in E-UTRAN, the following assumptions apply:

- both TDD and FDD will be supported;
- the provision of the UE Positioning function in E-UTRAN and EPC is optional through support of the specified method(s) in the eNode B and the E-SMLC;
- UE Positioning is applicable to any target UE, whether or not the UE supports LCS, but with restrictions on the use of certain positioning methods depending on UE capability (as defined within the LPP protocol);
- the positioning information may be used for internal system operations to improve system performance;
- the UE Positioning architecture and functions shall include the option to accommodate several techniques of measurement and processing to ensure evolution to follow changing service requirements and to take advantage of advancing technology;
- LMU aspects are left for implementation and are not standardized in this release.

4.2 Role of UE Positioning Methods

The E-UTRAN may utilise one or more positioning methods in order to determine the position of an UE.

Positioning the UE involves two main steps:

- signal measurements; and
- Position estimate and optional velocity computation based on the measurements.

The signal measurements may be made by the UE or the eNode B. The basic signals measured for terrestrial position methods are typically the E-UTRA radio transmissions; however, other methods may make use of other transmissions such as general radio navigation signals including those from Global Navigation Satellites Systems (GNSSs).

The positioning function should not be limited to a single method or measurement. That is, it should be capable of utilising other standard methods and measurements, as such methods and measurements are available and appropriate, to meet the required service needs of the location service client. This additional information could consist of readily available E-UTRAN measurements (FFS pending RAN1 conclusions).

The position estimate computation may be made by the UE or by the E-SMLC.

4.3 Standard UE Positioning Methods

The standard positioning methods supported for E-UTRAN access are:

- network-assisted GNSS methods;
- downlink positioning;
- enhanced cell ID method.

Hybrid positioning using multiple methods from the list of positioning methods above is also supported.

These positioning methods may be supported in UE-based, UE-assisted/E-SMLC-based, or eNB-assisted versions. Table 4.3-1 indicates which of these versions are supported in this version of the specification for the standardised positioning methods.

Table 4.3-1: Supported versions of UE positioning methods

Method	UE-based	UE-assisted, E-SMLC-based	eNB-assisted	SUPL
A-GNSS	Yes	Yes	No	Yes (UE-based and UE-assisted)
Downlink	Yes [FFS]	Yes	No	Yes (UE-assisted; UE-based FFS)
E-CID	FFS	Yes	Yes	Yes (UE-assisted; eNB-assisted)

4.3.1 Network-assisted GNSS Methods

These methods make use of UEs that are equipped with radio receivers capable of receiving GNSS signals.

Examples of GNSS include GPS, Modernized GPS, Galileo, GLONASS, Space Based Augmentation Systems (SBAS), and Quasi Zenith Satellite System (QZSS).

In this concept, different GNSSs (e.g. GPS, Galileo, etc.) can be used separately or in combination to determine the location of a UE.

The operation of the network-assisted GNSS methods is described in clause 8.1.

4.3.2 Downlink positioning

[FFS; downlink positioning is still under discussion in RAN1]

4.3.3 Enhanced Cell ID Methods

In the Cell ID (CID) positioning method, the position of an UE is estimated with the knowledge of its serving eNode B and cell. The information about the serving eNode B and cell may be obtained by paging, tracking area update, or other methods. Enhanced Cell ID (E-CID) positioning refers to techniques which use additional UE and/or E-UTRAN radio resource and other measurements to improve the UE location estimate.

Although E-CID positioning may utilise some of the same measurements as the measurement control system in the RRC protocol, the UE generally is not expected to make additional measurements for the sole purpose of positioning; i.e., the positioning procedures do not supply a measurement configuration or measurement control message, and the UE reports the measurements that it has available rather than being required to take additional measurement actions.

In cases with a requirement for close time coupling between UE and eNode B measurements (e.g., TADV type 1 and UE Tx-Rx time difference), the eNode B configures the appropriate RRC measurements and is responsible for maintaining the required coupling between the measurements. The operation of the Enhanced Cell ID method is described in clause 8.3.

5 E-UTRAN UE Positioning Architecture

Figure 5-1 shows the architecture in EPS applicable to positioning of a UE with E-UTRAN access.

The MME receives a request for some location service associated with a particular target UE from another entity (e.g., GMLC, eNB, or UE) or the MME itself decides to initiate some location service on behalf of a particular target UE (e.g., for an IMS emergency call from the UE) as described in [2]. The MME then sends a location services request to an E-SMLC. The E-SMLC processes the location services request which may include transferring assistance data to the target UE to assist with UE-based and/or UE-assisted positioning and/or may include positioning of the target UE. The E-SMLC then returns the result of the location service back to the MME (e.g., a position estimate for the UE and/or an indication of any assistance data transferred to the UE). In the case of a location service requested by an entity other than the MME (e.g., UE, eNB, or E-SMLC), the MME returns the location service result to this entity.

The SLP is the SUPL entity responsible for positioning over the user plane. Further details of the relationship of the user-plane positioning entities to the E-UTRAN control-plane positioning architecture are described in Annex B.

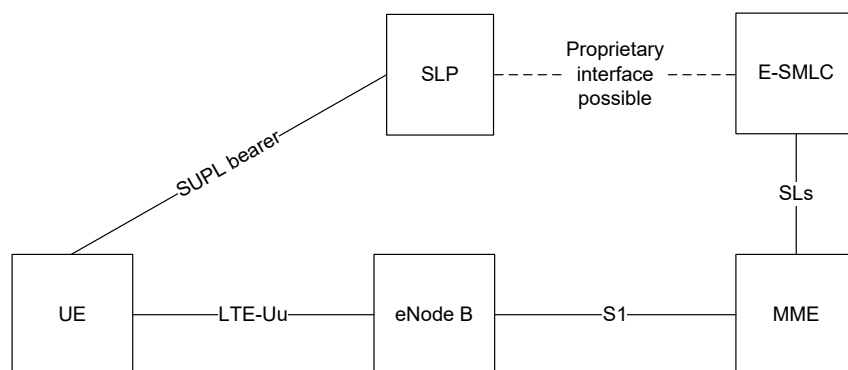

Figure 5-1: UE Positioning Architecture applicable to E-UTRAN

5.1 UE Positioning Operations

To support positioning of a target UE and delivery of location assistance data to a UE with E-UTRAN access in EPS, location related functions are distributed as shown in the architecture in Figure 5-1 and as clarified in greater detail in TS 23.271 [2]. The overall sequence of events applicable to the UE, E-UTRAN and E-SMLC for any location service is shown in Figure 5.1-1.

Note that the UE is assumed to be in connected mode before the beginning of the flow shown in the Figure 5.1-1; that is, any signalling that might be required to bring the UE to connected mode prior to step 1a is not shown.

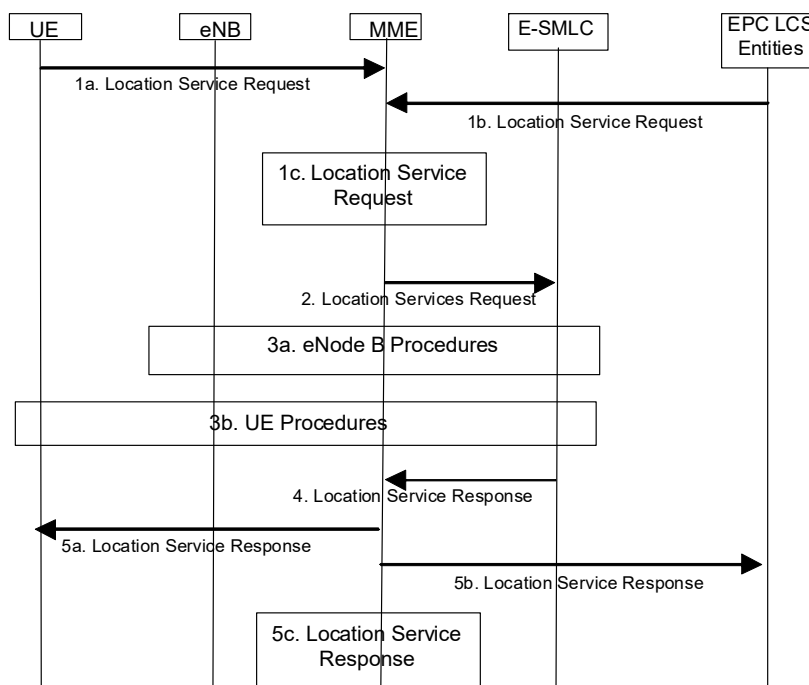

Figure 5.1-1: Location Service Support by E-UTRAN

- 1a. Either: the UE requests some location service (e.g. positioning or delivery of assistance data) to the serving MME at the NAS level.
- 1b. Or: some entity in the EPC (e.g. GMLC) requests some location service (e.g. positioning) for a target UE to the serving MME .
- 1c. Or: the serving MME for a target UE determines the need for some location service (e.g. to locate the UE for an emergency call).
2. The MME transfers the location service request to an E-SMLC.
- 3a. The E-SMLC instigates location procedures with the serving eNode B for the UE – e.g. to obtain positioning measurements or assistance data..
- 3b. In addition to step 3a or instead of step 3a, the E-SMLC instigates location procedures with the UE – e.g. to obtain a location estimate or positioning measurements or to transfer location assistance data to the UE.
4. The E-SMLC provides a location service response to the MME and includes any needed results – e.g. success or failure indication and, if requested and obtained, a location estimate for the UE.
- 5a. If step 1a was performed, the MME returns a location service response to the UE and includes any needed results – e.g. a location estimate for the UE.
- 5b. If step 1b was performed, the MME returns a location service response to the EPC entity in step 1b and includes any needed results – e.g. a location estimate for the UE.
- 5c. If step 1c occurred, the MME uses the location service response received in step 4 to assist the service that triggered this in step 1c (e.g. may provide a location estimate associated with an emergency call to a GMLC).

Location procedures applicable to E-UTRAN occur in steps 3a and 3b in Figure 5.1-2 and are defined in greater detail in this specification. Steps 1a and 5a are also applicable to E-UTRAN support because of a capability to tunnel signalling applicable to steps 3a and 3b. Other steps in Figure 5.1-2 are applicable only to the EPC and are described in greater detail and in TS 23.271 [2].

Steps 3a and 3b can involve the use of different position methods to obtain location related measurements for a target UE and from these compute a location estimate and possibly additional information like velocity. Positioning methods supported in this release are summarized in clause 4.3 and described in detail in clause 8.

When the eNode B functions as an LCS client, it delivers the Location Service Request to the E-SMLC via the MME, as shown in Figure 5.1-2.

Editor's Note: The details of this procedure are FFS pending confirmation from SA2.

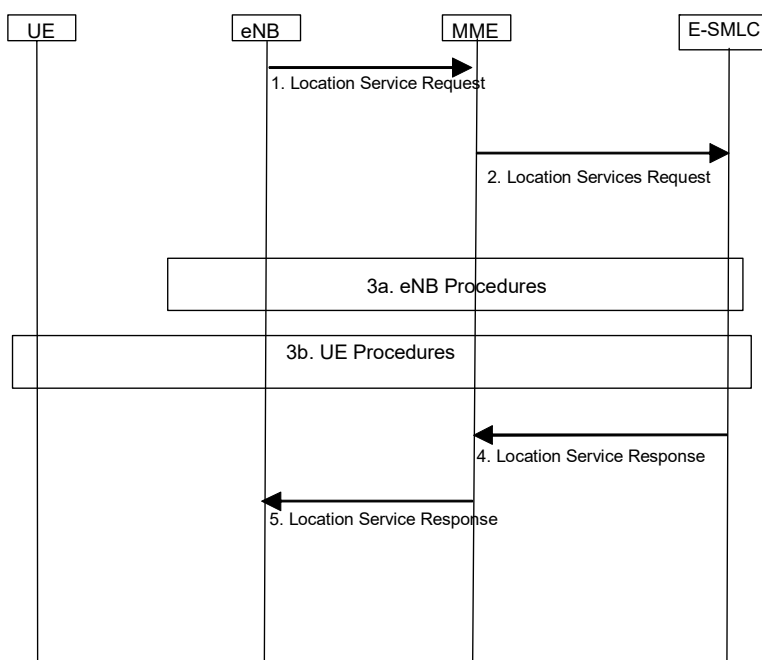

Figure 5.1-2: Location Service Support by E-UTRAN with eNode B as Client

1. The eNode B requests some location service (e.g. positioning) to the serving MME.
2. The MME transfers the location service request to an E-SMLC.
- 3a. The E-SMLC instigates location procedures with the serving eNode B for the UE – e.g. to obtain positioning measurements or assistance data.
- 3b. In addition to step 3a or instead of step 3a, the E-SMLC instigates location procedures with the UE – e.g. to obtain a location estimate or positioning measurements or to transfer location assistance data to the UE.
4. The E-SMLC provides a location service response to the MME and includes a location estimate for the UE.
5. The MME returns a location service response to the eNode B and includes any needed results – e.g. a location estimate for the UE.

It is FFS if handover during an LCS operation with an eNode B as the client requires any special handling.

5.2 E-UTRAN Positioning Operations

Separately from location service support for particular UEs, an E-SMLC may interact with elements in the E-UTRAN in order to obtain measurement information to help assist one or more position methods for all UEs.

Editor's Note: The details of the related procedures and signalling interactions will need to await RAN1 completion of downlink and possibly uplink position method evaluation and definition.

5.2.1 Downlink Position Method Support (FFS)

Editor's Note: It is FFS if LPPa is used to transfer assistance data for OTDOA as opposed to relying solely on other methods such as OAM. If LPPa is not used for this purpose this section would not be applicable.

An E-SMLC can interact with any eNodeB reachable from any of the MMEs with signaling access to the E-SMLC in order to obtain location related information to support the downlink position method. Location related information may be obtained either once on demand or on a repeated and triggered basis. The information can include timing information for the eNodeB in relation to either absolute GNSS time or timing of other eNodeBs and information about the supported cells including PRS schedule.

Signalling access between the E-SMLC and eNodeB is via any MME with signalling access to both the E-SMLC and eNodeB.

5.3 Functional Description of Elements Related to UE Positioning in E-UTRAN

5.3.1 User Equipment (UE)

The UE may transmit the needed signals for uplink-based UE Positioning measurements and may make measurements of downlink signals from E-UTRAN and other sources such as different GNSS systems. The measurements to be made will be determined by the chosen positioning method.

The UE may also contain LCS applications, or access an LCS application either through communication with a network accessed by the UE or through another application residing in the UE. This LCS application may include the needed measurement and calculation functions to determine the UE's position with or without network assistance. This is outside of the scope of this specification.

The UE may also, for example, contain an independent positioning function (e.g., GPS) and thus be able to report its position, independent of the E-UTRAN transmissions. The UE with an independent positioning function may also make use of assistance information obtained from the network.

5.3.2 Node B

eNode B is a network element of E-UTRAN that may provide measurement results for position estimation and makes measurements of radio signals for a target UE and communicates these measurements to an E-SMLC.

The eNode B may make its measurements in response to requests (e.g., from the E-SMLC), or it may autonomously measure and report regularly or when there are significant changes in radio conditions (e.g., changes in the E-UTRAN GPS timing of cell frames).

Editor's Note: Autonomous measurement and periodic measurement reporting by eNode B is FFS

5.3.3 Evolved Serving Mobile Location Centre (E-SMLC)

The E-SMLC manages the support of different location services for target UEs, including positioning of UEs and delivery of assistance data to UEs. The E-SMLC may interact with the serving eNode B for a target UE in order to obtain position measurements for the UE, including uplink measurements made by the eNode B and downlink measurements made by the UE that were provided to the eNode B as part of other functions such as for support of handover.

The E-SMLC may interact with a target UE in order to deliver assistance data if requested for a particular location service, or to obtain a location estimate if that was requested.

For positioning of a target UE, the E-SMLC decides on the position methods to be used, based on factors that may include the LCS Client type, the required QoS, UE positioning capabilities, and eNode B positioning capabilities. The E-SMLC then invokes these positioning methods in the UE and/or serving eNode B. The positioning methods may yield a location estimate for UE-based position methods and/or positioning measurements for UE-assisted and network-based position methods. The E-SMLC may combine all the received results and determine a single location estimate for the target UE (hybrid positioning). Additional information like accuracy of the location estimate and velocity may also be determined.

5.3.4 Location Measurement Unit (LMU)

LMU functionality is not included in this version of the specification.

6 Signalling protocols and interfaces

6.1 Network interfaces supporting positioning operations

6.1.1 General LCS control plane architecture

The general LCS control plane architecture in the EPS applicable to a target UE with E-UTRAN access is defined in [2].

6.1.2 LTE-Uu interface

The LTE-Uu interface, connecting the UE to the eNode B over the air, is used as one of several transport links for the LTE Positioning Protocol.

6.1.3 S1-MME interface

The S1-MME interface between the eNode B and the MME is transparent to all UE-positioning-related procedures. It is involved in these procedures only as a transport link for the LTE Positioning Protocol.

For eNode B related positioning procedures, the S1-MME interface transports both positioning requests from the E-SMLC to the eNode B and positioning results from the eNode B to the E-SMLC.

6.1.4 SLs interface

The SLs interface, between the E-SMLC and the MME, is transparent to all UE related and eNode B related positioning procedures. It is then used only as a transport link for the LTE Positioning Protocols LPP and LPPa.

The SLs interface supports location sessions instigated by the MME as defined in [2]. LPP and LPPa transport are then supported as part of any location session.

6.2 UE-terminated protocols

6.2.1 LTE Positioning Protocol (LPP)

The LTE Positioning Protocol (LPP) is terminated between the UE and the E-SMLC. It may use either the control- or user-plane protocols as underlying transport. In this specification, only control plane use of LPP is defined. User plane support of LPP is defined in [17] and [18].

LPP is a point to point positioning protocol with capabilities similar to those in UMTS RRC ([15]) and GERAN RRLP ([16]). Whereas RRLP supports positioning of a target MS accessing GERAN and RRC supports positioning of a target UE accessing UTRAN, LPP supports positioning and location related services (e.g. transfer of assistance data) for a target UE accessing E-UTRAN. To avoid creating new positioning protocols for future access types developed by 3GPP, and to enable positioning measurements for terrestrial access types other than E-UTRAN, LPP is in principle forward-compatible with other access types, even though restricted to E-UTRAN access in this specification.

LPP further supports the OMA user plane location solution SUPL 2.0, as defined in the OMA SUPL 2.0 standards ([17], [18]), and is intended to be compatible with the successor protocols of SUPL 2.0 as well.

LPP messages are carried as transparent PDUs across intermediate network interfaces using the appropriate protocols (e.g., S1-AP over the S1-MME interface, NAS/RRC over the Uu interface). The LPP protocol is intended to enable positioning for LTE using a multiplicity of different position methods, while isolating the details of any particular positioning method and the specifics of the underlying transport from one another.

The protocol operates on a transaction basis between a target device and a server, with each transaction taking place as an independent procedure. More than one such procedure may be in progress at any given moment. An LPP procedure may involve a request/response pairing of messages or one or more “unsolicited” messages. Each procedure has a single objective (e.g., transfer of assistance data, exchange of LPP related capabilities, or positioning of a target device according to some QoS and use of one or more positioning methods). Multiple procedures, in series and/or in parallel, can be used to achieve more complex objectives (e.g., positioning of a target device in association with transfer of assistance data and exchange of LPP related capabilities). Multiple procedures also enable more than one positioning attempt to be ongoing at the same time (e.g., to obtain a coarse location estimate with low delay while a more accurate location estimate is being obtained with higher delay).

For the 3GPP EPS Control Plane solution defined in [2], the UE is the target device and the E-SMLC is the server. For SUPL 2.0 support, the SUPL Enabled Terminal (SET) is the target device and the SUPL Location Platform (SLP) is the server. The protocol does not preclude the possibility of future developments in control plane and user plane solutions (e.g., possible successors of SUPL 2.0, as well as possible future 3GPP control plane solutions).

All LPP operations and procedures are defined with respect to the target and server, and thus the LPP operations and procedures defined here with respect to a UE and an E-SMLC can also be viewed in this more generic context by substituting any target for the UE and any server for the E-SMLC.

LPP further supports multiple positioning methods as defined in section 4.3.

LPP supports hybrid positioning, in which two or more position methods are used concurrently to provide measurements and/or a location estimate or estimates to the server. LPP is forward compatible with the later addition of other position methods in later releases (e.g., position methods associated with other types of terrestrial access).

The operations controlled through LPP are described further in section 7.1.

6.2.2 Radio Resource Control (RRC)

The RRC protocol is terminated between the eNode B and the UE. In addition to providing transport for LPP messages over the Uu interface, it supports transfer of measurements that may be used for positioning purposes through the existing measurement systems specified in [14].

6.3 eNB-terminated protocols

6.3.1 LTE Positioning Protocol Annex (LPPa)

The LTE Positioning Protocol Annex (LPPa) carries information between the eNode B and the E-SMLC. It is used to support the following positioning functions:

- E-CID cases where assistance data or measurements are transferred from the eNode B to the E-SMLC
- data collection from eNodeBs for support of downlink OTDOA positioning (FFS)

Editor’s Note: It is FFS whether the protocol is transparent to the MME or allows for some MME involvement in LPP procedures.

6.3.2 S1 Application Protocol (S1-AP)

The S1-AP protocol, terminated between the MME and the eNode B, is used as transport for LPP and LPPa messages over the S1-MME interface. The S1-AP protocol is also used to instigate and terminate eNode B related positioning procedures.

6.4 Signalling between an E-SMLC and UE

6.4.1 Protocol Layering

Figure 6.4.1-1 shows the protocol layering used to support transfer of LPP messages between an E-SMLC and UE. The abbreviations for all protocols follow those used in [19], with the additions of LPP and LCS-AP (LCS application

protocol) which denotes a possible new protocol that might be functionally similar to parts of BSSAP-LE (TS 49.031), BSSLAP (TS 48.071) and RANAP (TS 25.413).

Editor's Note: The protocol layering below is copied exactly from [24]. The layers below LPP on the SLs interface between the MME and E-SMLC are expected to be defined by CT4. Once this has occurred, the figure below can be updated if needed.

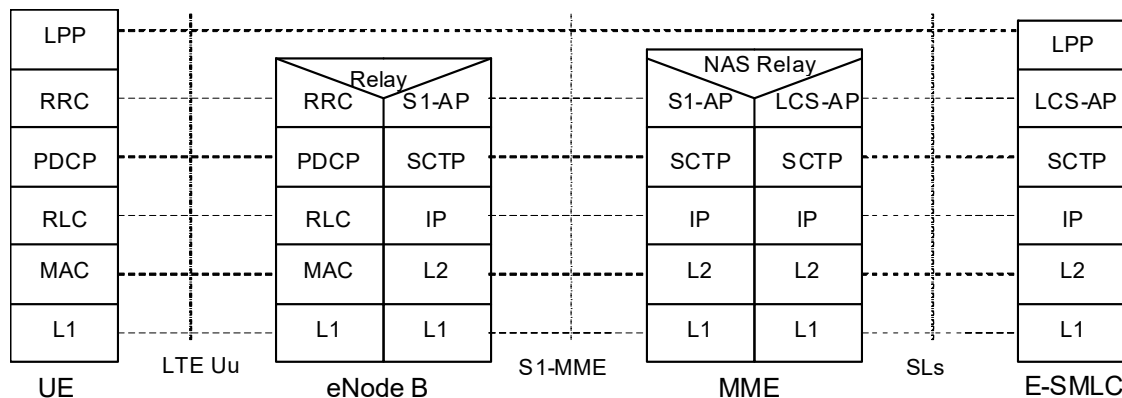

Figure 6.4.1-1: Protocol Layering for E-SMLC to UE Signalling

6.4.2 LPP PDU Transfer

Figure 6.4.2-1 shows the transfer of an LPP PDU between an E-SMLC and UE, in the network- and UE-triggered cases. These two cases may occur separately or as parts of a single more complex operation.

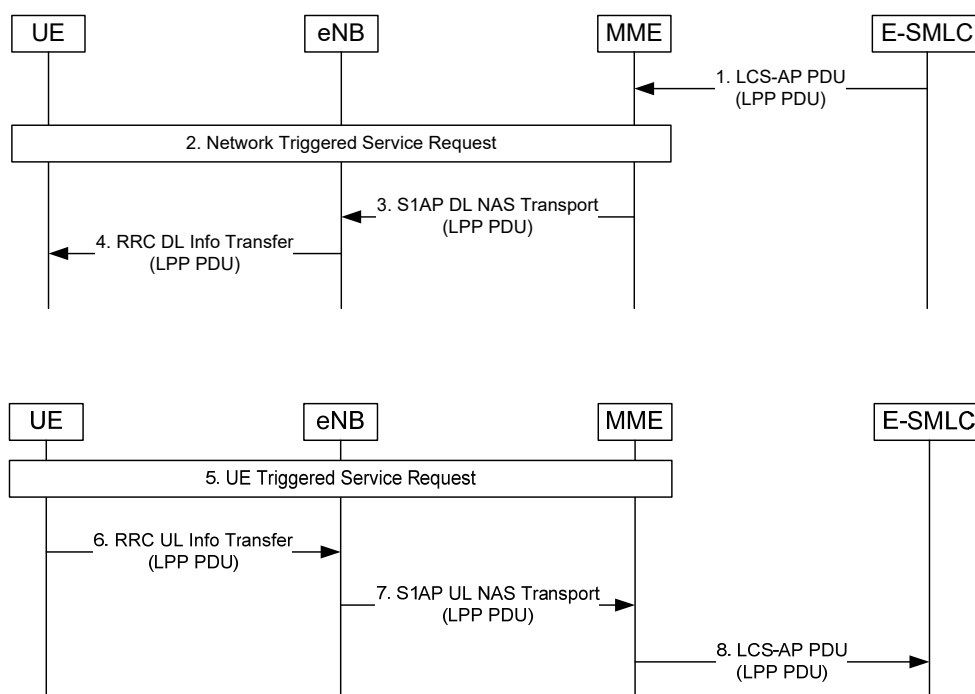

Figure 6.4.2-1: LPP PDU transfer between E-SMLC and UE (network- and UE-triggered cases)

1. Steps 1 to 4 may occur before, after, or at the same time as steps 5 to 8. Steps 1 to 4 and steps 5 to 8 may also be repeated. Steps 1 to 4 are triggered when the E-SMLC needs to send an LPP message to the UE as part of some LPP positioning activity. The E-SMLC then sends an LCS-AP PDU to the MME carrying an LPP PDU comprising the message.

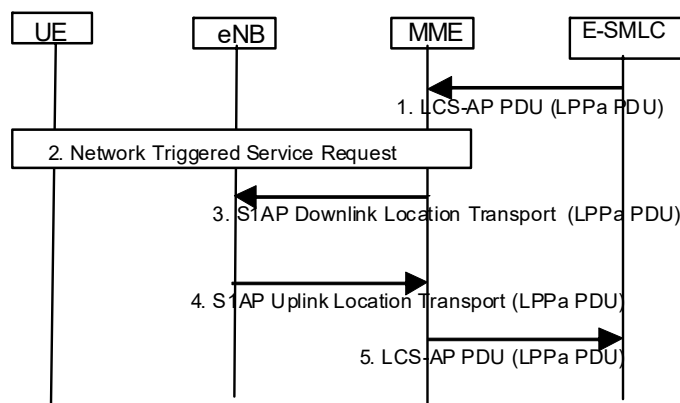

Figure 6.5.2-1: LPPa PDU Transfer between an E-SMLC and eNode B for UE Positioning

- Steps 1 to 3 are triggered when the E-SMLC needs to send an LPPa message to the serving eNode B for a target UE as part of an LPPa positioning activity. The E-SMLC then sends an LCS-AP PDU to the MME carrying an LPPa PDU comprising the message.
- If the UE is in ECM-IDLE state, the MME performs a network triggered service request as defined in TS 23.401 [19] in order to establish a signalling connection with the UE and assign a serving eNode B.
- The MME forwards the LPPa PDU to the serving eNode B in an SIAP Downlink Location Transport message and includes a correlation ID related to the MME to E-SMLC location session on the SLs interface. The MME need not retain state information for this transfer – e.g. can treat any response in step 4 as a separate non-associated transfer.

Editor's Note: The exact transport message to be used in this step is FFS.

- Steps 4 and 5 are triggered when a serving eNode B needs to send an LPPa message to the E-SMLC for a target UE as part of an LPPa positioning activity. The eNode B then sends an LPPa PDU to the MME in an SIAP Uplink Location Transport message and includes the correlation ID received in step 3 and the current ECGI.
- The MME forwards the LPPa PDU to the E-SMLC associated with the correlation ID received in step 4 in an LCS-AP PDU and includes the ECGI. Steps 1 to 5 may be repeated.

Editor's Note: the above procedure will need to be reviewed after RAN1 has defined the downlink and any uplink positioning methods and after LPPa has been defined at a stage 2 level to support these methods.

6.5.3 LPPa PDU Transfer for Positioning Support

Editor's Note: It is FFS if LPPa is used to transfer assistance data for OTDOA as opposed to relying solely on other methods such as OAM. If LPPa is not used for this purpose this section would not be applicable.

Figure 6.5.3-1 shows LPPa PDU transfer between an E-SMLC and eNode B when related to gathering data from the eNodeB for positioning support for all UEs.

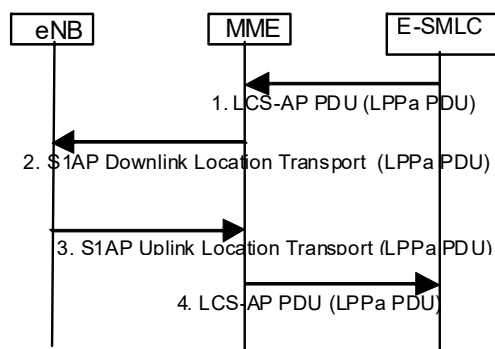

Figure 6.5.3-1: LPPa PDU Transfer between an E-SMLC and eNode B for obtaining eNodeB Data

1. Steps 1 and 2 are triggered when the E-SMLC needs to send an LPPa message to an eNode B to obtain data related to the eNodeB. The E-SMLC determines an MME with access to the eNodeB and then sends an LCS-AP PDU to the MME carrying an LPPa PDU and the identity of the eNodeB.
2. The MME forwards the LPPa PDU to the identified eNode B in an S1AP Downlink Location Transport message and includes the identity of the E-SMLC. The MME need not retain state information for this transfer – e.g. can treat any response in step 3 as a separate non-associated transfer.
3. Steps 3 and 4 are triggered when an eNode B needs to send an LPPa PDU to an E-SMLC containing data applicable to the eNB. The eNode B determines an MME with access to the E-SMLC and then sends an LPPa PDU to the MME in an S1AP Uplink Location Transport message. The eNodeB includes the identity of the E-SMLC.
4. The MME forwards the LPPa PDU to the E-SMLC indicated in step 3 in an LCS-AP PDU. Steps 1 to 4 may be repeated.

7 General E-UTRAN UE Positioning procedures

7.1 General LPP procedures for UE Positioning

7.1.1 LPP Procedures

Positioning procedures in the E-UTRAN are modelled as transactions of the LPP protocol using the procedures defined in this specification. A procedure consists of a single operation of one of the following types:

- Exchange of positioning capabilities;
- Transfer of assistance data;
- Transfer of location information (positioning measurements and/or position estimate).

Parallel procedures are permitted. A single LPP message may (FFS) contain information relating to more than one procedure (though not all combinations of procedure types are permitted; applicable restrictions on particular types of procedures are described in the corresponding sections).

As described in section 6.2.1, the protocol operates between a “target” and a “server”. In the control-plane context, these entities are the UE and E-SMLC respectively; in the SUPL context they are the SET and the SLP. The terms “target” and “server” are used in the flows in this section to avoid redundancy between the two versions of the positioning operations. A procedure may be initiated by either the target or the server.

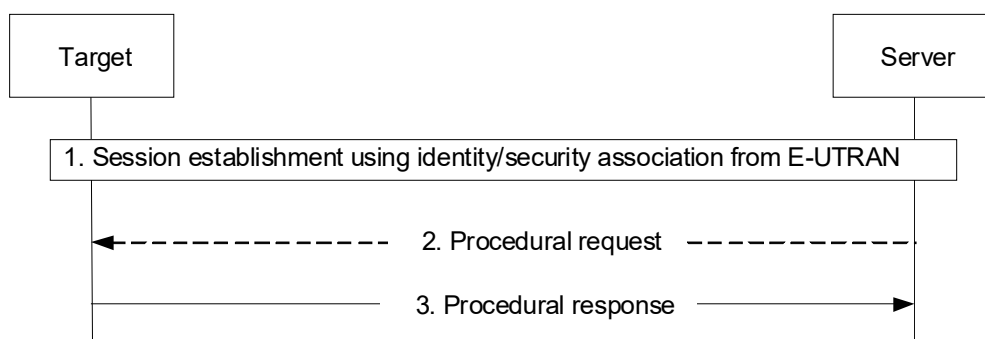

Figure 7.1.1-1: A single LPP procedure

Figure 7.1.1-1 shows a single LPP procedure taking place immediately after session establishment. The request in step 2 is optional. Although the figure shows the request as being originated by the server and the response by the target, the reverse is also possible (with some restrictions for certain procedure types).

7.1.2 Positioning procedure types

7.1.2.1 Capability exchange

Editor's Note: It is currently assumed that a UE request for capability from E-SMLC or delivery of the E-SMLC capability to the UE is not supported.

Capabilities in an LPP context refer to the ability of a target or server to support different position methods defined for LPP, different aspects of a particular position method (e.g. different types of assistance data for A-GNSS) and common features not specific to only one position method (e.g. ability to handle multiple LPP transactions). These capabilities are defined within the LPP protocol and transferred between the target and the server using LPP transport.

Editor's Note: It is FFS whether the MME may be involved in the transfer of capabilities.

The exchange of capabilities between a target and a server may be initiated by a request or sent as “unsolicited” information. If a request is used, the server sends an LPP message to the target device with a request for capability information. The target sends an LPP message containing a capability response.

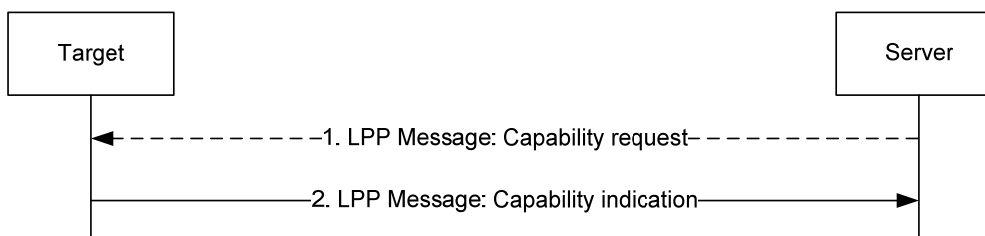

Figure 7.1.2-1: Capability transfer

1. Optionally, the server may send a request for the LPP related capabilities of the target.
2. Either in response to step 1 or unilaterally, the target transfers its LPP-related capabilities to the server. The capabilities may refer to particular position methods or may be common to multiple position methods.

7.1.2.2 Assistance data transfer

Assistance data may be transferred either by request or unsolicited. If a request is used, the target sends an LPP message to the server indicating the request; the server then delivers one or more LPP messages with assistance data.

In this version of the specification, assistance data delivery is supported only via unicast transport from server to target.

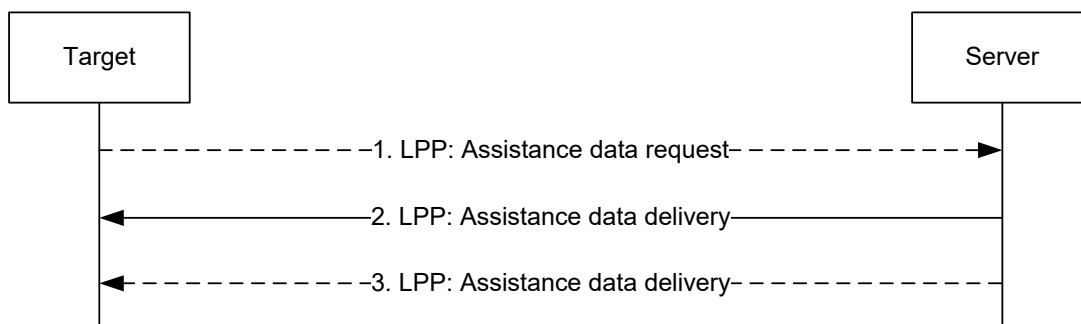

Figure 7.1.2-2: Assistance data transfer

1. Optionally, the target may send a request to the server for assistance data and may indicate the particular assistance data needed.
2. Either in response to step 1 or unilaterally, the server transfers assistance data to the target. The transferred assistance data should match any assistance data requested in step 1 if this step occurred.
3. Optionally (e.g., if requested in step 1), the server may transfer additional assistance data to the target in one or more additional LPP messages.

This procedure is unidirectional; assistance data are always delivered from the server to the target. In the event that multiple instances of assistance data are delivered (i.e., if step 3 occurs), the several instances are all considered as portions of a single procedure.

7.1.2.3 Location information transfer

The term “location information” applies both to an actual position estimate and to values used in computing position (e.g., radio measurements or positioning measurements). It is delivered either in response to a request or unsolicited.

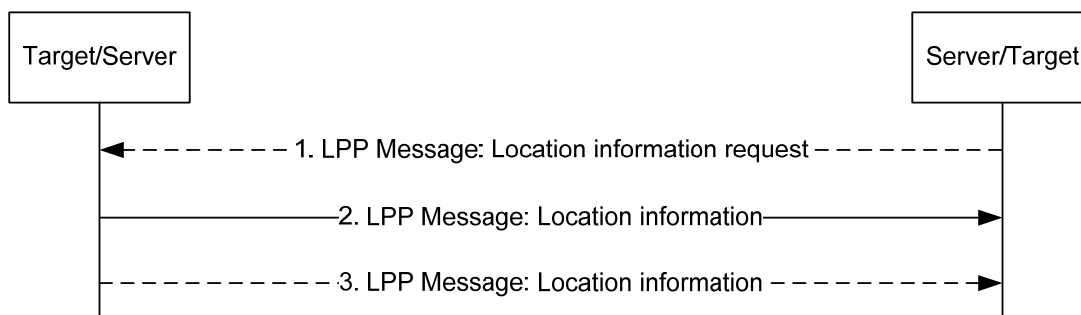

Figure 7.1.2-3: Location information transfer

1. Optionally, the server or target (the node indicated as “Server/Target” in Figure 7.1.2-3) may send a request for location information to the other node (indicated as “Target/Server”), and may indicate the type of location information needed and associated QoS.
2. Either in response to step 1 or unilaterally, the target or server (“Target/Server”) transfers location information to the other node (“Endpoint B”). If step 1 was performed, the location information transferred should match the location information requested in step 1.
3. Optionally (e.g., if requested in step 1), the source node in step 2 may transfer additional location information to the recipient node in one or more additional LPP messages.

This procedure is bidirectional at the LPP level; either the target or the server may take the role of either endpoint in Figure 7.1.2-3. Note, however, that particular constituents of the LPP messages used for this procedure may sometimes be sent in only one direction; e.g., while a location estimate may be valid in both directions, certain radio measurements may only be allowed from a target to a server.

7.1.2.4 Multiple procedures

Multiple LPP procedures may be in progress simultaneously between the same target and server nodes, to improve flexibility and efficiency. However, no more than one positioning procedure between a particular pair of target and server nodes to obtain location information shall be in progress at any time for the same position method.

In this example, the objective is to provide the target with an estimate of its location, in a situation in which the target's LPP capabilities are not known in advance to the server, and additional assistance data are required by the target. A message flow is shown in Figure 7.1.2.-4.

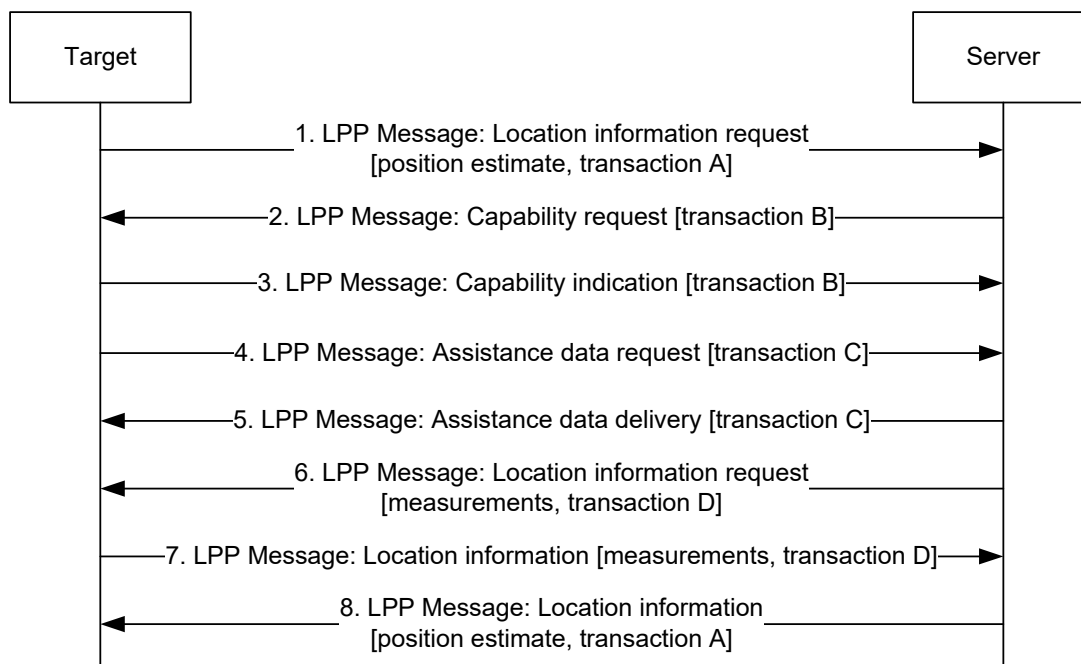

Figure 7.1.2-4: Example of multiple LPP procedures

1. The target sends a request to the server for its geographic location and may include the required QoS.
2. The server returns a request for the LPP related capabilities of the target.
3. The target returns its LPP related capabilities (e.g., positioning methods supported).
4. The target sends a request for particular assistance data. Note that step 4 could take place simultaneously with step 3 (i.e., using a single transport message to carry the two LPP messages; whether this concatenation would occur within LPP or by including multiple LPP PDUs in the transport message is a stage 3 aspect).
5. The server returns the assistance data requested in step 4.
6. The server sends a request for location information (e.g., for location related measurements for position methods supported by the target as indicated in step 3). Note that step 6 could be combined with step 5 in a single transport message.
7. The target obtains and returns the location information (e.g., positioning method measurements) requested in step 6.
8. The server computes a location estimate for the target, using the location information received in step 7, and returns this to the target, completing the procedure started in step 1.

7.1.2.5 Sequence of Procedures

LPP procedures are not required to occur in any fixed order, in order to provide greater flexibility in positioning. Thus, a UE may request assistance data at any time in order to comply with a previous request for location measurements from the E-SMLC; an E-SMLC may instigate more than one request for location information (e.g., measurements or a

location estimate) in case location results from a previous request were not adequate for the requested QoS; and the target device may transfer or request capability information to the server at any time if not already performed.

Despite the flexibility allowed by LPP, it is expected that procedures will normally occur in the following order:

1. Transfer Capabilities;
2. Transfer Assistance Data;
3. Transfer Location information (measurements and/or location estimate).

Specific examples for each positioning method are shown in clause 8.

7.2 General LPPa Procedures for UE Positioning

7.2.1 LPPa Procedures

Positioning and data acquisition procedures between an E-SMLC and eNodeB are modelled as transactions of the LPPa protocol using the procedures defined in this specification. A procedure consists of a single operation of one of the following types:

- Transfer of location information for a particular UE (e.g. positioning measurements)
- Transfer of information applicable to the eNodeB (e.g. eNB timing differences)

NOTE: exchange of capabilities between an eNodeB and E-SMLC and transfer of assistance data may not be needed (e.g. since capability information can be provisioned through O&M)

Parallel procedures between the same E-SMLC and eNodeB are supported, with the restriction that parallel procedures concerning the same positioning method are not supported (the exact scope of this restriction is FFS).

For possible extensibility, the protocol is considered to operate between a generic "access node" (e.g. eNodeB) and a "server" (e.g. E-SMLC). A procedure may be initiated by either end.

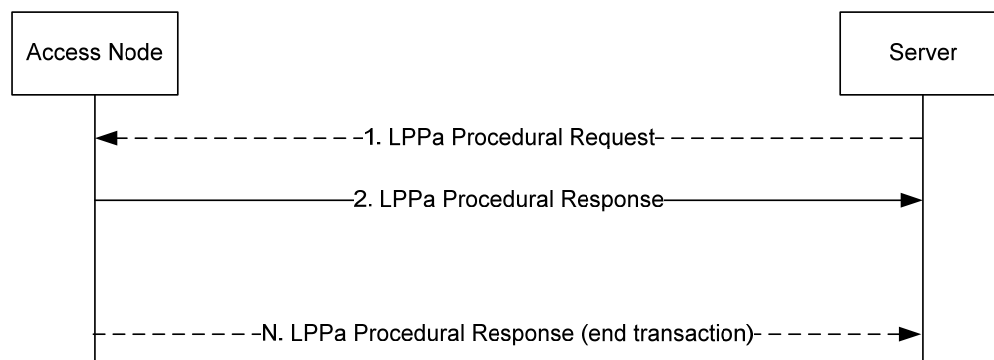

Figure 7.2.1-1: A single LPPa procedure

Figure 7.1.2-1 shows a single LPPa procedure. The request in step 1 is optional. The procedure is terminated in step 2 in the case of a UE associated procedure. For a non-UE associated procedure to gather information concerning the access node, additional responses may be allowed (e.g. sending of updated information periodically and/or whenever there is some significant change). In this case, the procedure may be ended after some additional responses.

7.2.2 LPPa procedure types

7.2.2.1 Location information transfer

The term "location information" applies both to an actual position estimate and to values used in computing position (e.g., radio measurements or positioning measurements). It is delivered either in response to a request or unsolicited.

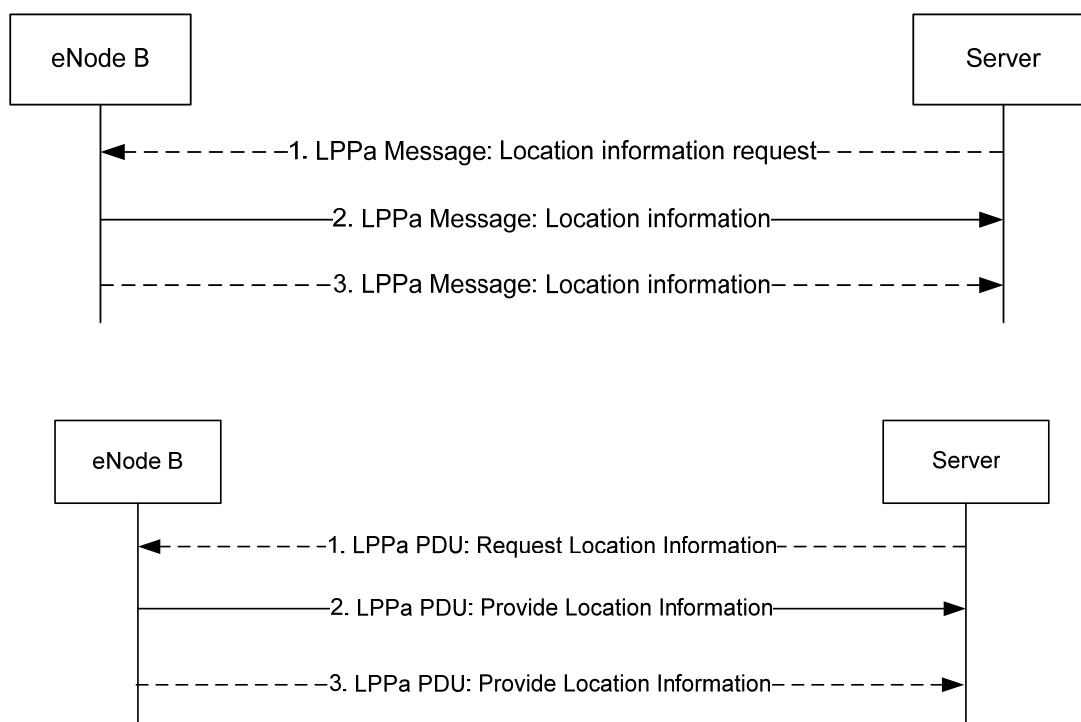

Figure 7.2.2-1: Location information transfer

1. The server optionally (FFS) sends a request for location related information to the eNode B, and may indicate the type of location information needed and associated QoS. The server also indicates whether this refers to a particular UE or only to the access node.

Editor's Note: If the eNode B is not permitted to initiate delivery of location information, then step 1 in this procedure would become mandatory.

2. Either in response to step 1 or unilaterally, the eNode B transfers location related information to the server. The location related information transferred should match the location related information requested in step 1 if step 1 occurs.
3. Optionally (e.g., if requested in step 1 if step 1 occurs), the eNode B may transfer additional location related information to the server in one or more additional LPPa messages.

7.3 Service Layer Support using combined LPP and LPPa Procedures

As described in [2], UE-positioning-related services can be instigated from the EPC in the case of an NI-LR or MT-LR location service, or from the UE in the case of an MO-LR location service. The complete sequence of operations in the EPC is defined in [2]. This subclause defines the overall sequences of operations that occur in the E-SMLC, E-UTRAN and UE as a result of the EPC operations.

Some flows in this scenario apply only in particular situations (e.g., only when the UE is in connected mode). The lower-layer details of such cases are not shown in the diagrams; for instance, the process of paging a UE to bring it to connected mode from idle is not explicitly indicated in these diagrams.

7.3.1 NI-LR and MT-LR Service Support

Figure 7.3.1-1 shows the sequence of operations for an NI-LR or MT-LR location service, starting at the point where the MME initiates the service in the E-SMLC.

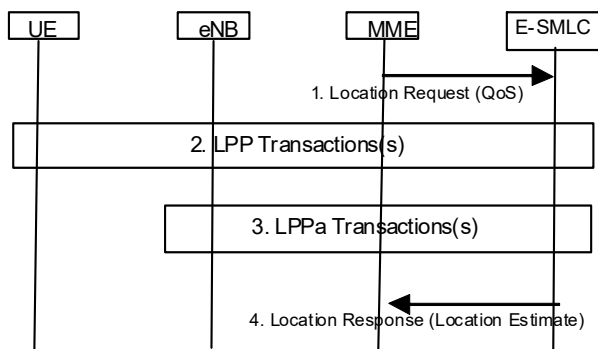

Figure 7.3.1-1: UE Positioning Operations to support an MT-LR or NI-LR

1. The MME sends a location request to the E-SMLC for a target UE and may include associated QoS.
2. The E-SMLC may obtain location related information from the UE and/or from the serving eNode B. In the former case, the E-SMLC instigates one or more LPP procedures to transfer UE positioning capabilities, provide assistance data to the UE and/or obtain location information from the UE. The UE may also instigate one or more LPP procedures after the first LPP message is received from the E-SMLC (e.g., to request assistance data from the E-SMLC).
3. If the E-SMLC needs location related information for the UE from the eNode B, the E-SMLC instigates one or more LPPa procedures. Step 3 is not necessarily serialised with step 2; if the E-SMLC and eNode B have the information to determine what procedures need to take place for the location service, step 3 could precede or overlap with step 2.
4. The E-SMLC returns a location response to the MME with any location estimate obtained as a result of steps 2 and 3.

7.3.2 MO-LR Service Support

Figure 7.3.2-1 shows the sequence of operations for an MO-LR service, starting at the point where an LCS Client in the UE or the user has requested some location service (e.g., retrieval of the UE's location or transfer of the UE's location to a third party).

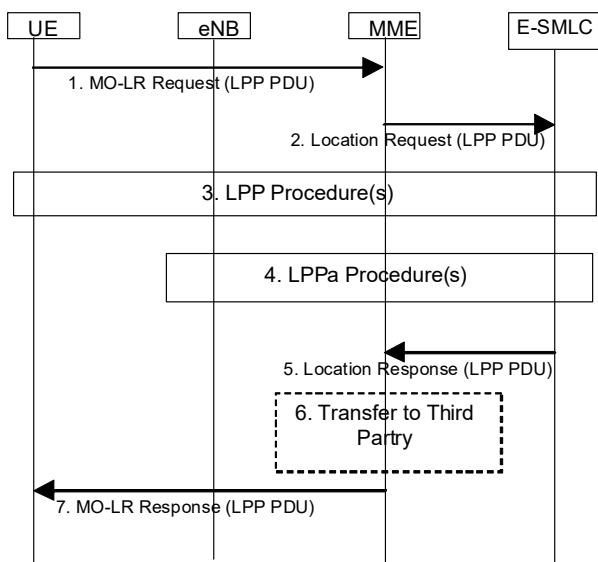

Figure 7.3.2-1: UE Positioning Operations to support an MO-LR

1. The UE sends a NAS level MO-LR request to the MME. The MO-LR request may carry an LPP PDU to instigate one or more LPP procedures to transfer capabilities, request assistance data, request location information and/or transfer location information (e.g. location measurements).
2. The MME sends a location request to the E-SMLC and includes any LPP PDU received in step 1.
3. The E-SMLC may obtain location related information from the UE and/or from the serving eNode B. In the former case or if an immediate response is needed to any LPP procedure instigated by the UE in step 1 (e.g., a request for assistance data), the E-SMLC instigates one or more LPP procedures to transfer UE positioning capabilities, provide assistance data to the UE and/or obtain location information from the UE. The UE may also instigate further LPP procedures after the first LPP message is received from the E-SMLC (e.g., to request assistance data or to request further assistance data).
4. If the E-SMLC needs location related information for the UE from the eNode B, the E-SMLC instigates one or more LPPa procedures. Step 4 may also precede step 3 or occur in parallel with it.
5. The E-SMLC returns a location response to the MME with any location estimate obtained as a result of steps 3 and 4, and/or with a final LPP message (e.g., that could provide a location estimate to the UE if requested by the UE in step 1).
6. If the UE requested location transfer to a third party the MME transfers the location received from the E-SMLC in step 5 to the third party as defined in [2].
7. The MME sends a NAS level MO-LR response to the UE, carrying any final LPP PDU that was received in step 5.

8 Positioning methods and Supporting Procedures

8.1 GNSS positioning methods

8.1.1 General

Global Navigation Satellite System (GNSS) is the standard generic term for satellite navigation systems that provide autonomous geo-spatial positioning with global or regional coverage. The following GNSSs are supported in this version of the specification:

- GPS and its modernization [6,7,8];
- Galileo [9];
- GLONASS [10];
- Satellite Based Augmentation Systems (SBAS), including WAAS, EGNOS, MSAS, and GAGAN [12];
- Quasi-Zenith Satellite System (QZSS) [11].

Each global GNSS can be used individually or in combination with others. When used in combination, the effective number of navigation satellite signals would be increased:

- extra satellites can improve availability (of satellites at a particular location) and results in an improved ability to work in areas where satellite signals can be obscured, such as in urban canyons;
- extra satellites and signals can improve reliability, i.e., with extra measurements the data redundancy is increased, which helps identify any measurement outlier problems;
- extra satellites and signals can improve accuracy due to improved measurement geometry and improved ranging signals from modernized satellites.

When GNSS is designed to inter-work with the E-UTRAN, the network assists the UE GNSS receiver to improve the performance in several respects. These performance improvements will:

- reduce the UE GNSS start-up and acquisition times; the search window can be limited and the measurements speed up significantly;
- increase the UE GNSS sensitivity; positioning assistance messages are obtained via E-UTRAN so the UE GNSS receiver can operate also in low SNR situations when it is unable to demodulate GNSS satellite signals;
- allow the UE to consume less handset power than with stand-alone GNSS; this is due to rapid start-up times as the GNSS receiver can be in idle mode when it is not needed.

The network-assisted GNSS methods rely on signalling between UE GNSS receivers (possibly with reduced complexity) and a continuously operating GNSS reference receiver network, which has clear sky visibility of the same GNSS constellation as the assisted UEs. Two assisted modes are supported:

- *UE-Assisted*: The UE performs GNSS measurements (pseudo-ranges, pseudo Doppler, etc.) and sends these measurements to the E-SMLC where the position calculation takes place, possibly using additional measurements from other (non GNSS) sources;
- *UE-Based*: The UE performs GNSS measurements and calculates its own location, possibly using additional measurements from other (non GNSS) sources.

The assistance data content may vary depending on whether the UE operates in UE-Assisted or UE-Based mode.

The assistance data signalled to the UE can be broadly classified into:

- *data assisting the measurements*: e.g. reference time, visible satellite list, satellite signal Doppler, code phase, Doppler and code phase search windows;
- *data providing means for position calculation*: e.g. reference time, reference position, satellite ephemeris, clock corrections.

A UE with GNSS measurement capability may also operate in an autonomous (standalone) mode. In autonomous mode the UE determines its position based on signals received from GNSS without assistance from the network.

8.1.2 Information to be transferred between E-UTRAN Elements

This subclause defines the information (e.g., assistance data, measurement data) that may be transferred between E-UTRAN elements.

8.1.2.1 Information that may be transferred from the E-SMLC to UE

Table 8.1.2-1 lists assistance data for both UE-assisted and UE-based modes that may be sent from the E-SMLC to the UE.

NOTE: The provision of these assistance data elements and the usage of these elements by the UE depend on the E-UTRAN and UE capabilities, respectively.

Table 8.1.2-1: Information that may be transferred from the E-SMLC to UE

Assistance Data
Reference Time
Reference Location
Ionospheric Models
Earth Orientation Parameters
GNSS-GNSS Time Offsets
Differential GNSS Corrections
Ephemeris and Clock Models
Real-Time Integrity
Data Bit Assistance
Acquisition Assistance
Almanac
UTC Models

8.1.2.1.1 Reference Time

Reference Time assistance provides the GNSS receiver with coarse or fine GNSS time information. The specific GNSS system times (e.g., GPS, Galileo, Glonass system time) shall be indicated with a GNSS ID.

In case of coarse time assistance only, the Reference Time provides an estimate of the current GNSS system time (where the specific GNSS is indicated by a GNSS ID). The E-SMLC should achieve an accuracy of +/- 3 seconds for this time including allowing for the transmission delay between E-SMLC and UE.

In case of fine time assistance, the Reference Time provides the relation between GNSS system time (where the specific GNSS is indicated by a GNSS ID) and E-UTRAN air-interface timing.

8.1.2.1.2 Reference Location

Reference Location assistance provides the GNSS receiver with an a priori estimate of its location (e.g., obtained via Cell-ID, downlink positioning, etc.) together with its uncertainty.

The geodetic reference frame shall be WGS-84, as specified in [4].

8.1.2.1.3 Ionospheric Models

Ionospheric Model assistance provides the GNSS receiver with parameters to model the propagation delay of the GNSS signals through the ionosphere. Ionospheric Model parameters as specified by GPS [6], Galileo [9], and QZSS [11] may be provided.

8.1.2.1.4 Earth Orientation Parameters

Earth Orientation Parameters (EOP) assistance provides the GNSS receiver with parameters needed to construct the ECEF-to-ECI coordinate transformation as specified by GPS [6].

8.1.2.1.5 GNSS-GNSS Time Offsets

GNSS-GNSS Time Offsets assistance provides the GNSS receiver with parameters to correlate GNSS time (where the specific GNSS is indicated by a GNSS-1 ID) of one GNSS with other GNSS time (where the specific GNSS is indicated by a GNSS-2 ID). GNSS-GNSS Time Offsets parameters as specified by GPS [6], Galileo [9], Glonass [10], and QZSS [11] may be provided.

8.1.2.1.6 Differential GNSS Corrections

Differential GNSS Corrections assistance provides the GNSS receiver with pseudo-range and pseudo-range-rate corrections to reduce biases in GNSS receiver measurements as specified in [13]. The specific GNSS for which the corrections are valid is indicated by a GNSS-ID.

8.1.2.1.7 Ephemeris and Clock Models

Ephemeris and Clock Models assistance provides the GNSS receiver with parameters to calculate the GNSS satellite position and clock offsets. The various GNSSs use different model parameters and formats, and all parameter formats as defined by the individual GNSSs are supported by the signalling.

8.1.2.1.8 Real-Time Integrity

Real-Time Integrity assistance provides the GNSS receiver with information about the health status of a GNSS constellation (where the specific GNSS is indicated by a GNSS ID).

8.1.2.1.9 Data Bit Assistance

Data Bit Assistance provides the GNSS receiver with information about data bits or symbols transmitted by a GNSS satellite at a certain time (where the specific GNSS is indicated by a GNSS ID). This information may be used by the UE for sensitivity assistance (data wipe-off) and time recovery.

8.1.2.1.10 Acquisition Assistance

Acquisition Assistance provides the GNSS receiver with information about visible satellites, reference time, expected code-phase, expected Doppler, search windows (i.e., code and Doppler uncertainty) and other information of the GNSS signals (where the specific GNSS is indicated by a GNSS ID) to enable a fast acquisition of the GNSS signals.

8.1.2.1.11 Almanac

Almanac assistance provides the GNSS receiver with parameters to calculate the coarse (long-term) GNSS satellite position and clock offsets. The various GNSSs use different model parameters and formats, and all parameter formats as defined by the individual GNSSs are supported by the signalling.

8.1.2.1.12 UTC Models

UTC Models assistance provides the GNSS receiver with parameters needed to relate GNSS system time (where the specific GNSS is indicated by a GNSS ID) to Universal Coordinated Time. The various GNSSs use different model parameters and formats, and all parameter formats as defined by the individual GNSSs are supported by the signalling.

8.1.2.2 Information that may be transferred from the UE to E-SMLC

The information that may be signalled from UE to the E-SMLC is listed in table 8.1.2-2.

Table 8.1.2-2: Information that may be transferred from UE to the E-SMLC

Information	UE-assisted	UE-based/ standalone
Latitude/Longitude/Altitude, together with uncertainty shape	No	Yes
Velocity, together with uncertainty shape	No	Yes
Reference Time, possibly together with GNSS-E-UTRAN time association and uncertainty	Yes	Yes
Indication of used positioning methods in the fix	No	Yes
Code phase measurements	Yes	No
Doppler measurements	Yes	No
Carrier phase measurements	Yes	No
Measurement quality parameters for each measurement	Yes	No
Additional, non-GNSS related measurement information	Yes	No

8.1.2.2.1 GNSS Measurement Information

The GNSS measurement information reported from the UE to the E-SMLC depends on the GNSS mode (i.e., UE-based, autonomous (standalone), or UE-assisted).

8.1.2.2.1.1 UE-based mode

In UE-based or standalone mode, the GNSS receiver reports the latitude, longitude and possibly altitude, together with an estimate of the location uncertainty, if available.

If requested by the E-SMLC and supported by the UE, the GNSS receiver may report its velocity, possibly together with an estimate of the uncertainty, if available.

If requested by the E-SMLC and supported by the UE, the GNSS receiver may report the relation between GNSS system time (where the specific GNSS is indicated by a GNSS ID; the specific GNSS system time may be selected by the UE) and E-UTRAN air-interface timing. This information may be used by the E-SMLC to assist other UEs in the network.

The UE should also report an indication of which GNSSs and possibly other location methods have been used to calculate a fix.

8.1.2.2.1.2 UE-assisted mode

In UE-assisted mode, the GNSS receiver reports the Code Phase and Doppler measurements together with associated quality estimates. These measurements enable the E-SMLC to calculate the location of the UE, possibly using other measurements and data.

If requested by the E-SMLC and supported by the UE, the GNSS receiver may report Carrier Phase measurements together with associated quality measurements, if available.

If requested by the E-SMLC and supported by the UE, the GNSS receiver may report the relation between GNSS system time (where the specific GNSS is indicated by a GNSS ID; the specific GNSS system time may be selected by the UE) and E-UTRAN air-interface timing. This information may be used by the E-SMLC to assist other UEs in the network.

8.1.2.2.2 Additional Non-GNSS Related Information

Additional non-GNSS measurements performed by E-UTRAN or UE may be used by the E-SMLC or UE to calculate or verify a location estimate. This information may include downlink positioning measurements, pathloss and signal strength related measurements, etc.

8.1.3 Assisted-GNSS Positioning Procedures

8.1.3.1 Position Capability Transfer Procedure

The purpose of this procedure is to enable the E-SMLC to obtain the positioning capabilities of the UE.

8.1.3.1.1 E-SMLC-initiated (UE to E-SMLC) Position Capability Transfer

Figure 8.1.3-1 shows the Position Capability Transfer operations for the network-assisted GNSS method when position capabilities are transferred from the UE to the E-SMLC.

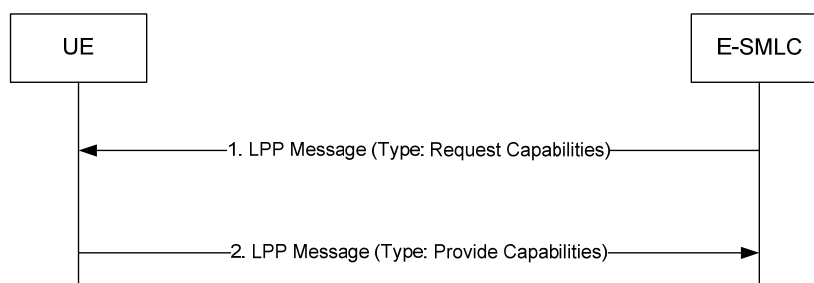

Figure 8.1.3-2: E-SMLC-initiated Position Capability Transfer

- (1) Optionally, the E-SMLC determines that the positioning capabilities of the UE are needed and sends an LPP message to the UE including a Request Capabilities type. The request indicates that the A-GNSS capabilities of the UE are needed and may indicate a request for the capabilities of other position methods also.
- (2) When the UE has received an LPP message of type Request Capabilities that includes a request for A-GNSS capabilities or unilaterally in the absence of step 1, the UE sends an LPP message of type Provide Capabilities to the E-SMLC. This message includes the A-GNSS positioning capabilities of the UE, including the GNSSs and signals per GNSS supported, GNSS modes supported, A-GNSS associated hybrid mode combinations supported. The LPP message may also indicate the UE support for specific GNSS measurements, such as carrier phase measurements, velocity, or fine time assistance measurements and may include the types of assistance data supported by the UE. If step 1 occurred and the UE cannot fulfill the request, a LPP message of type Error is sent instead, providing the specific error reason.

8.1.3.2 Assistance Data Delivery Procedure

The purpose of this procedure is to enable the E-SMLC to provide assistance data to the UE (e.g., as part of a positioning procedure) and the UE to request assistance data from the E-SMLC (e.g., as part of a positioning procedure or for autonomous self location (i.e., UE determines its own location)).

8.1.3.2.1 E-SMLC initiated Assistance Data Delivery

Figure 8.1.3-5 shows the Assistance Data Delivery operations for the network-assisted GNSS method when the procedure is initiated by the E-SMLC.

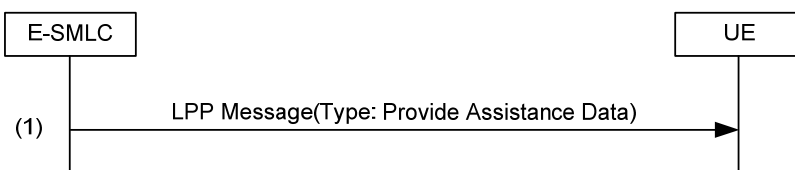

Figure 8.1.3-6: E-SMLC-initiated Assistance Data Delivery Procedure

- (1) The E-SMLC determines that assistance data needs to be provided to the UE (e.g., as part of a positioning procedure) and sends an LPP message of type Provide Assistance Data to the UE. This PDU may include any of the GNSS assistance data defined in subclause 8.1.2.1. The entire set of assistance data may be delivered in one or several LPP messages, e.g., one message per GNSS. In this case, this step may be repeated by the E-SMLC several times.

8.1.3.2.2 UE initiated Assistance Data Delivery

Figure 8.1.3-7 shows the Assistance Data Delivery operations for the network-assisted GNSS method when the procedure is initiated by the UE.

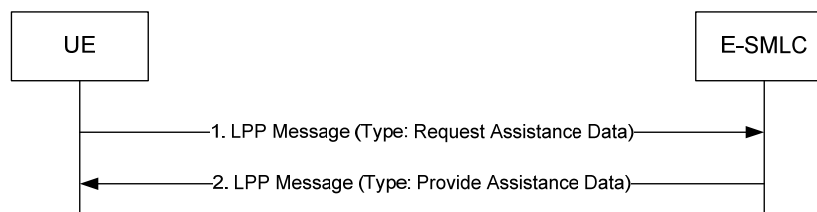

Figure 8.1.3-8: UE-initiated Assistance Data Delivery Procedure

- (1) The UE determines that certain A-GNSS assistance data are desired (e.g., in case the UE requires its own location with autonomous self location or as part of a positioning procedure when the E-SMLC provided assistance data are not sufficient for the UE to fulfill the request) and sends a LPP message of type Request Assistance Data to the E-SMLC. This request includes an indication of which specific A-GNSS assistance data are requested for each GNSS, possibly together with additional information (e.g., for which GNSS signal types, or satellites, or times the assistance is requested, etc.). Additional information concerning the UE's approximate location and serving and neighbour cells may also be provided in the Request Assistance Data message and/or in an accompanying Provide Location Information message to help the E-SMLC provide appropriate assistance data. This additional data may include the UE's last known location if available, the cell IDs of the UE serving eNodeB and possibly neighbour eNodeBs, as well as E-CID measurements.
- (2) The E-SMLC provides the requested assistance in a LPP message of type Provide Assistance Data, if available at the E-SMLC. The entire set of assistance data may be delivered in one or several LPP messages, e.g., one message per GNSS. In this case, this step may be repeated by the E-SMLC several times. If any of the UE requested assistance data in step (1) are not provided in step 2, the UE shall assume that the requested assistance data are not supported, or currently not available at the E-SMLC. If none of the UE requested assistance data in step (1) can be provided by the E-SMLC, an LPP message of type Error is sent by the E-SMLC instead, providing the error reason.

8.1.3.3 Position Measurement Procedure

The purpose of this procedure is to enable the E-SMLC to request position measurements or location estimate from the UE, or to enable the UE to provide location measurements to the E-SMLC for position calculation (e.g., in case of basic self location where the UE requests its own location).

8.1.3.3.1 E-SMLC initiated Position Measurement

Figure 8.1.3-9 shows the Position Measurement operations for the network-assisted GNSS method when the procedure is initiated by the E-SMLC.

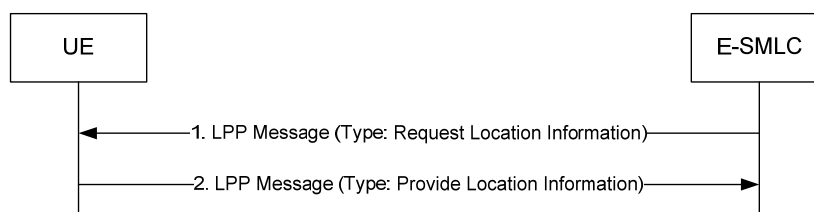

Figure 8.1.3-10: E-SMLC-initiated Position Measurement Procedure

- (1) Optionally, the E-SMLC sends a LPP message of type Request Location Information to the UE for invocation of A-GNSS positioning. This request includes positioning instructions such as the GNSS mode (UE-assisted, UE-based, UE-based preferred but UE-assisted allowed, UE-assisted preferred, but UE-based allowed, standalone), positioning methods (GPS, Galileo, Glonass, etc. and possibly non-GNSS methods, such as downlink positioning or E-CID), specific UE measurements requested if any, such as fine time assistance measurements, velocity, carrier phase, multi-frequency measurements, and quality of service parameters (accuracy, response time).
- (2) If step 1 occurred, the UE performs the requested measurements and possibly calculates its own location. Alternatively, if step 1 did not occur, the UE may initiate step 2 and obtain measurements in the absence of a request – e.g. to provide to the E-SMLC in association with the procedure in Figure 8.1.3-12. The UE sends an LPP message of type Provide Location Information to the E-SMLC before the Response Time provided in step (1) elapsed if step 1 occurred. If step 1 occurred and the UE is unable to perform the requested measurements, or if the Response Time provided in step 1 elapsed before any of the requested measurements have been obtained, the UE sends a LPP message of type Error instead, providing the error reason.

8.1.3.3.2 UE-initiated Position Measurement

Figure 8.1.3-11 shows the Position Measurement operations for the network-assisted GNSS method when the procedure is initiated by the UE. This procedure may be used by the UE in case of basic self location for UE-assisted mode (i.e., UE requests its own location).

Editor's note: This figure is not entirely aligned with the generic flow shown in section 5.1 regarding the triggering of the location operation. The details of the flow are FFS and some coordination with other groups is required to converge on upper-layer aspects.

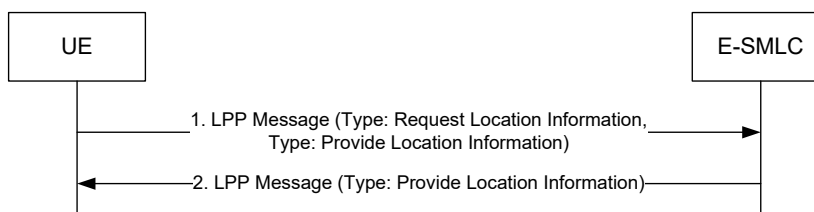

Figure 8.1.3-12: UE-initiated Position Measurement Procedure (Basic Self Location)

- (1) The UE sends a LPP message of type Request Location Information to the E-SMLC, including preferred location methods and quality of service parameters (accuracy and response time). The UE may also include an associated Provide Location Information message as described in step 2 of Figure 8.1.3-10 containing A-GNSS and

possibly other measurements. The Provide Location Information type may include any UE measurements (GNSS pseudo-ranges, and other measurements) already available at the UE and supported by the E-SMLC.

- (2) If the E-SMLC is able to calculate the UE position and velocity (if requested), it returns the location and velocity (possibly together with uncertainty information) to the UE in a LPP message of type Provide Location Information. If the E-SMLC cannot obtain the UE location, a LPP message of type Error is sent instead, providing the specific error reason.

8.2 Downlink positioning method

Editor's Note: Downlink positioning is still under discussion in RAN1. This section is based on the available information at the time of writing, but the contents cannot be considered definitive until RAN1 have concluded.

8.2.1 General

In the downlink positioning method, the UE positioning is estimated based on measurements taken at the UE of downlink radio signals from multiple eNode Bs, along with knowledge of the geographical coordinates of the measured eNode Bs and their relative downlink timing.

The specific positioning techniques used to estimate the UE's location from this information are beyond the scope of this specification.

8.2.2 Information to be transferred between E-UTRAN Elements

This subclause defines the information that may be transferred between E-UTRAN elements.

8.2.2.1 Assistance Data that may be transferred from the E-SMLC to UE

The following assistance data may be transferred from the E-SMLC to the UE:

- Physical cell IDs (PCIs) and global cell IDs (GCIs) of candidate cells for measurement;
- Timing relative to the serving eNode B of candidate cells;
- Geographical coordinates of candidate cells and/or of the serving eNode B.

Some assistance data are needed only for certain forms of a downlink positioning procedure (e.g., for UE-based only).

Editor's Note: It is FFS if UE-based downlink positioning is supported in this version of the specification.

8.2.2.2 Assistance Data that may be transferred from the eNode B to E-SMLC

The following assistance data may be transferred from the eNode B to the E-SMLC:

- PCI and GCI of the cells under the eNode B and/or of cells under other eNode Bs;
- Timing information on the eNode B and/or of other eNode Bs;
- Geographical candidates of the eNode B and/or of other eNode Bs.

An eNode B may provide assistance data relating only to itself, or it may supply the E-SMLC with assistance data relating to several eNode Bs (e.g., relative timing information).

NOTE: The assistance data described in this section are not necessarily transferred only from the eNode B, and in some deployment options may not be delivered from the eNode B at all; they may also be delivered to the E-SMLC through OA&M or other mechanisms external to the E-UTRAN. In addition, in cases where assistance data are delivered from the eNode B, how the eNode B acquires the data is outside the scope of this specification.

8.2.2.3 Location Information that may be transferred from the UE to E-SMLC

The information that may be signalled from UE to the E-SMLC is listed in Table 8.2.2-1. The individual UE measurements are defined in [20, 21].

Table 8.2.2-1: Information that may be transferred from UE to the E-SMLC

Information	Measurements
Downlink Measurement Results List for EUTRA	Physical cell IDs
	Global cell IDs
	Downlink timing measurements

Editor's Note: The details of the measurements are FFS.

8.2.3 Downlink Positioning Procedures

The procedures described in this subclause support downlink positioning measurements obtained by the UE and provided to the E-SMLC using LPP, or obtained by the eNode B and provided to the E-SMLC using LPPa.

Editor's Note: This section describes only UE-assisted downlink positioning.

8.2.3.1 Position Capability Transfer Procedure

The purpose of this procedure is to enable the E-SMLC to obtain the positioning capabilities of the UE.

8.2.3.1.1 E-SMLC-initiated Position Capability Transfer

Figure 8.2.3-1 shows the Position Capability Transfer operations for the downlink method when the request for the position capabilities is initiated by the E-SMLC.

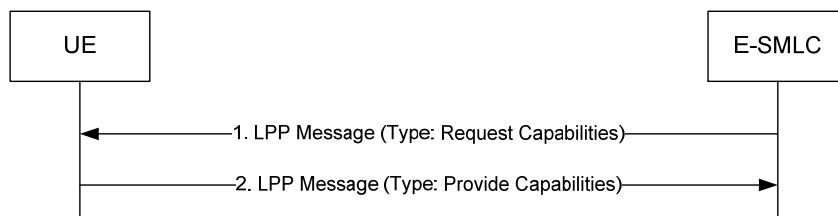

Figure 8.2.3-1: E-SMLC-initiated Position Capability Transfer

- (1) Optionally, the E-SMLC determines that the positioning capabilities of the UE are needed and sends an LPP message to the UE including a Request Capabilities type. The request indicates that the downlink positioning capabilities of the UE are needed and may include a request for the capabilities of other position methods as well.
- (2) If step 1 occurs, or if the UE determines to send its capabilities to the E-SMLC in an unsolicited manner, the UE sends an LPP message of type Provide Capabilities to the E-SMLC. This message shall include the positioning capabilities of the UE requested in step 1 (or determined by the UE in the absence of step 1), including the measurements supported for downlink positioning.

8.2.3.2 Assistance Data Delivery Procedure

8.2.3.2.1 Assistance Data Delivery between E-SMLC and UE

The purpose of this procedure is to enable the E-SMLC to provide assistance data to the UE (e.g., as part of a positioning procedure) and the UE to request assistance data from the E-SMLC (e.g., as part of a positioning procedure or for autonomous self location (i.e., UE determines its own location)).

8.2.3.2.1.1 E-SMLC-initiated assistance data delivery to the UE

Figure 8.2.3-3 shows the Assistance Data Delivery operations for the network downlink positioning method when the procedure is initiated by the E-SMLC.

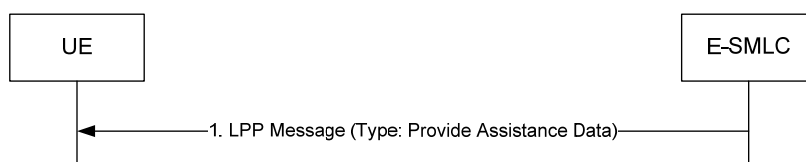

Figure 8.2.3-3: E-SMLC-initiated Assistance Data Delivery Procedure

- (1) The E-SMLC determines that assistance data needs to be provided to the UE (e.g., as part of a positioning procedure) and sends an LPP message of type Provide Assistance Data to the UE. This message may include any of the downlink positioning assistance data defined in subclause 8.2.2.1.

8.2.3.2.1.2 UE-initiated assistance data delivery to the UE

Figure 8.2.3-4 shows the Assistance Data Delivery operations for the downlink positioning method when the procedure is initiated by the UE.

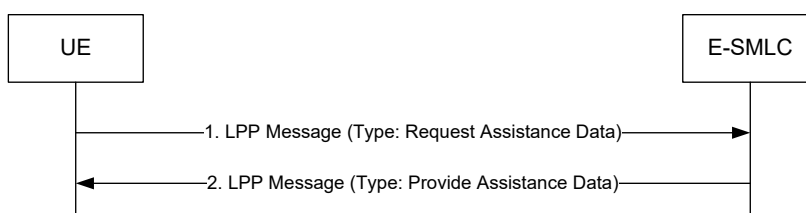

Figure 8.2.3-4: UE-initiated Assistance Data Delivery Procedure

- (1) The UE determines that certain downlink positioning assistance data are desired (e.g., in case the UE requires its own location with autonomous self location, or as part of a positioning procedure when the E-SMLC-provided assistance data are not sufficient for the UE to fulfill the request) and sends an LPP message of type Request Assistance Data to the E-SMLC. This request includes an indication of which specific downlink assistance data are requested. Additional information concerning the UE's approximate location and serving and neighbour cells may also be provided in the Request Assistance Data message and/or in an accompanying Provide Location Information message to help the E-SMLC provide appropriate assistance data. This additional data may include the UE's last known location if available, the cell IDs of the UE serving eNodeB and possibly neighbour eNodeBs, as well as E-CID measurements.
- (2) The E-SMLC provides the requested assistance in an LPP message of type Provide Assistance Data, if available at the E-SMLC. If any of the UE requested assistance data in step (1) are not provided in step 2, the UE shall assume that the requested assistance data are not supported, or currently not available at the E-SMLC. If none of the UE requested assistance data in step (1) can be provided by the E-SMLC, an LPP message of type Error is sent by the E-SMLC instead, providing the error reason.

8.2.3.2.2 Assistance Data Delivery between E-SMLC and eNode B

Editor's Note: It is FFS if LPPa is used to transfer assistance data for OTDOA as opposed to relying solely on other methods such as OAM. If LPPa is not used for this purpose this section would not be applicable.

The purpose of this procedure is to enable the eNode B to provide assistance data to the E-SMLC, for subsequent delivery to the UE using the procedures of subclause 8.2.3.2.1 or for use in the calculation of positioning estimates at the E-SMLC.

8.2.3.2.2.1 eNode B-initiated assistance data delivery to the E-SMLC

Figure 8.2.3-5 shows the Assistance Data Delivery operation from the eNode B to the E-SMLC for the network downlink positioning method, in the case where the procedure is initiated by the eNode B.

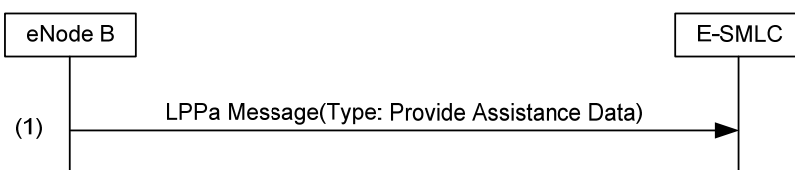

Figure 8.2.3-5: E-SMLC-initiated Assistance Data Delivery Procedure

- (1) The eNode B determines that assistance data need to be provided to the E-SMLC (e.g., as part of a periodic update or in response to a change in assistance data) and sends an LPPa message of type Provide Assistance Data to the E-SMLC. This message may include any of the downlink positioning assistance data defined in subclause 8.2.2.1.

8.2.3.2.2.2 E-SMLC-initiated assistance data delivery to the E-SMLC

Figure 8.2.3-6 shows the Assistance Data Delivery operation from the eNode B to the E-SMLC for the downlink positioning method, in the case that the procedure is initiated by the E-SMLC.

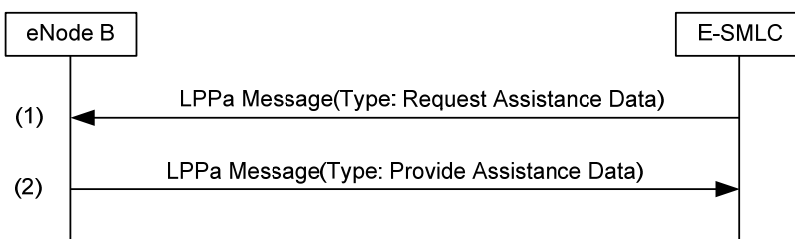

Figure 8.2.3-6: E-SMLC-initiated Assistance Data Delivery Procedure

- (1) The E-SMLC determines that certain downlink positioning assistance data are desired (e.g., as part of a periodic update or as triggered by OAM) and sends an LPPa message of type Request Assistance Data to the eNode B. This request includes an indication of which specific downlink assistance data are requested.
- (2) The eNode B provides the requested assistance in an LPPa message of type Provide Assistance Data, if available at the eNode B. If the requested assistance data in step (1) are not provided in step 2, an LPPa message of type Error is sent by the eNode B instead, providing the error reason.

8.2.3.3 Position Measurement Procedure

The purpose of this procedure is to enable the E-SMLC to request position measurements from the UE, or to enable the UE to provide location measurements to the E-SMLC for position calculation (e.g., in case of basic self location where the UE requests its own location).

8.2.3.3.1 E-SMLC-initiated Position Measurement

Figure 8.2.3-7 shows the Position Measurement operations for the downlink positioning method when the procedure is initiated by the E-SMLC.

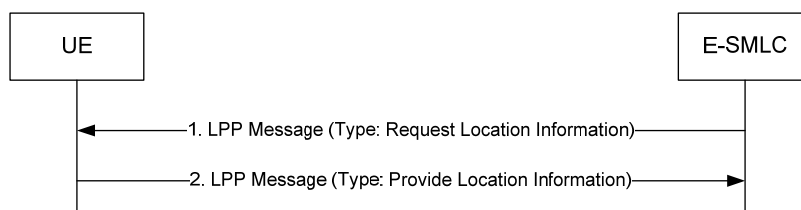

Figure 8.2.3-7: E-SMLC-initiated Position Measurement Procedure

- (1) Optionally, the E-SMLC sends an LPP message of type Request Location Information to the UE. This request includes indication of downlink measurements requested, including any needed measurement configuration information, and required response time.
- (2) If step 1 occurs, or if the UE determines to provide unsolicited downlink measurements to the E-SMLC (e.g. as part of the procedure in Figure 8.2.3-8), the UE obtains downlink measurements as requested in step 1, or as determined by the UE in the absence of step 1. The UE then sends an LPP message of type Provide Location Information to the E-SMLC, before the Response Time provided in step (1) elapsed if step 1 occurred, and includes the obtained downlink measurements. If step 1 occurred and if the UE is unable to perform the requested measurements, or the Response Time elapsed before any of the requested measurements were obtained, the UE sends an LPP message of type Error instead, providing the error reason.

8.2.3.3.2 UE-initiated Position Measurement

Figure 8.2.3-8 shows the Position Measurement operations for the downlink positioning method when the procedure is initiated by the UE. This procedure may be used by the UE in case of basic self location (i.e., UE requests its own location).

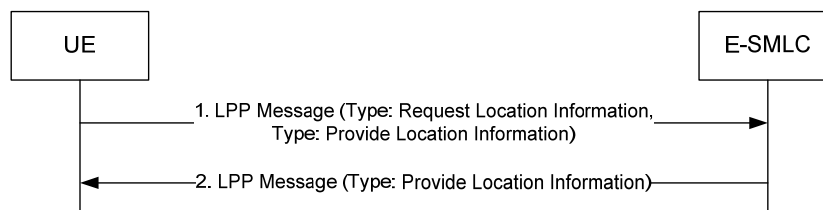

Figure 8.2.3-8: UE-initiated Position Measurement Procedure (Basic Self Location)

- (1) The UE sends an LPP message of type Request Location Information to the E-SMLC, including preferred location methods and quality of service parameters (accuracy and response time). The UE may also include a Provide Location Information type, as described in step 2 of Figure 8.2.3-7, containing downlink positioning (and possibly other) measurements. The Provide Location Information type may include any UE downlink measurements already available at the UE and supported by the E-SMLC.
- (2) If the E-SMLC is able to calculate the position, it returns the location (possibly together with uncertainty information) to the UE in an LPP message of type Provide Location Information. If the E-SMLC can not obtain the UE location, an LPP message of type Error is sent instead, providing the specific error reason.

8.3 Enhanced cell ID positioning methods

8.3.1 General

In the Cell ID (CID)-based method, the UE position is estimated with the knowledge of the geographical coordinates of its serving eNodeB. Enhanced Cell ID (E-CID) positioning refers to techniques which use additional UE and/or E-UTRAN radio resource related measurements to improve the UE location estimate. For E-UTRAN access, these measurements may include [20, 21]:

UE measurements ([20], [21]):

- E-UTRA carrier RSSI;

- Reference signal received power (RSRP);
- Reference Signal Received Quality (RSRQ);
- UE Rx – Tx time difference.

E-UTRAN measurements ([20], [21]):

- eNB Rx – Tx time difference
- Timing Advance (T_{ADV}):
 - Type1: $T_{ADV} = (\text{eNB Rx – Tx time difference}) + (\text{UE Rx – Tx time difference})$
 - Type2: $T_{ADV} = \text{eNB Rx – Tx time difference}$;
- Angle of Arrival (AoA).

Various techniques exist to use these measurements to estimate the location of the UE. The specific techniques are beyond the scope of this specification.

8.3.2 Information to be transferred between E-UTRAN Elements

This subclause defines the information (e.g., measurement data) that may be transferred between E-UTRAN elements.

8.3.2.1 Information that may be transferred from the E-SMLC to UE

UE-assisted Enhanced Cell-ID location does not require any assistance data to be transferred from the E-SMLC to the UE.

UE-Based Enhanced Cell-ID location is FFS.

8.3.2.2 Information that may be transferred from the UE to E-SMLC

The information that may be signalled from UE to the E-SMLC is listed in table 8.3.2-2.

Table 8.3.2-2: Information that may be transferred from UE to the E-SMLC

Information	UE-assisted	UE-based [FFS]
Latitude/Longitude/Altitude, together with uncertainty shape	No	FFS
Evolved Cell Global Identifier (ECGI)/Physical Cell ID	Yes	No
E-UTRA carrier RSSI	Yes	No
Reference signal received power (RSRP)	Yes	No
Reference Signal Received Quality (RSRQ)	Yes	No
UE Rx – Tx time difference	Yes	No

8.3.2.3 Information that may be transferred from the eNB to E-SMLC

The information that may be signalled from eNB to the E-SMLC is listed in table 8.3.2-3.

Table 8.3.2-3: Information that may be transferred from eNB to the E-SMLC

Information
Timing Advance (T_{ADV})
Angle of Arrival (AoA)
E-UTRA Measurement Results List:
- Evolved Cell Global Identifier (ECGI)/Physical Cell ID
- E-UTRA carrier RSSI (FFS)
- Reference signal received power (RSRP) (FFS)
- Reference Signal Received Quality (RSRQ) (FFS)

8.3.3 Downlink E-CID Positioning Procedures

The procedures described in this subclause support E-CID related measurements obtained by the UE and provided to the E-SMLC using LPP. The term “downlink” is intended to indicate that from the E-SMLC perspective the involved measurements are provided by the UE; this set of procedures might also be considered as “UE-assisted, E-SMLC-based E-CID”.

It is FFS if UE-based E-CID positioning will be supported in this version of the specification.

8.3.3.1 Position Capability Transfer Procedure

The purpose of this procedure is to enable the E-SMLC to obtain the positioning capabilities of the UE.

8.3.3.1.1 E-SMLC-initiated (UE to E-SMLC) Position Capability Transfer

Figure 8.3.3-1 shows the Position Capability Transfer operations for the E-CID method when position capabilities are transferred from the UE to the E-SMLC.

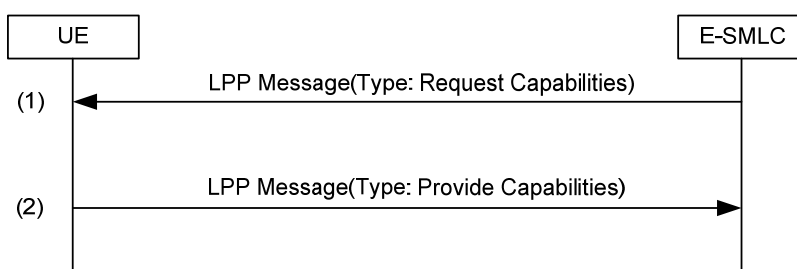

Figure 8.3.3-1: E-SMLC-initiated Position Capability Transfer.

- (1) Optionally, the E-SMLC determines that the positioning capabilities of the UE are needed and sends a LPP message to the UE including a Request Capabilities type. The request indicates that the E-CID capabilities of the UE are needed and may indicate a request for the capabilities of other position methods also.
- (2) When the UE has received an LPP message of type Request Capabilities that includes a request for E-CID capabilities or unilaterally in the absence of step 1, the UE sends an LPP message of type Provide Capabilities to the E-SMLC. This message includes the E-CID positioning capabilities of the UE, including the E-CID measurements supported as listed in Table 8.3.2-2. If step 1 occurred and the UE cannot fulfill the request, a LPP message of type Error is sent instead, providing the specific error reason.

8.3.3.2 Assistance Data Delivery Procedure

Editor’s Note: UE-based E-CID is FFS.

8.3.3.3 Position Measurement Procedure

The purpose of this procedure is to enable the E-SMLC to request position measurements from the UE, or to enable the UE to provide location measurements to the E-SMLC for position calculation (e.g., in case of basic self location where the UE requests its own location).

8.3.3.3.1 E-SMLC-initiated Position Measurement

Figure 8.3.3-3 shows the Position Measurement operations for the E-CID method when the procedure is initiated by the E-SMLC.

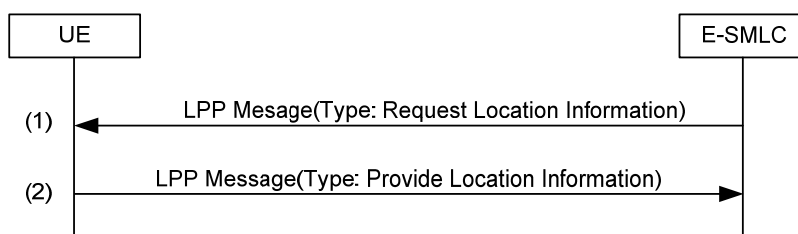

Figure 8.3.3-3: E-SMLC-initiated Position Measurement Procedure.

- (1) Optionally, the E-SMLC sends a LPP message of type Request Location Information to the UE for invocation of E-CID positioning. This request includes the E-CID measurements requested by the E-SMLC and supported by the UE as listed in Table 8.3.2-2 together with a required response time.
- (2) If step 1 occurred, the UE performs the requested measurements. Alternatively, if step 1 did not occur, the UE may initiate step 2 and obtain measurements in the absence of a request – e.g. to provide to the E-SMLC in association with the procedure in Figure 8.3.3-4. The UE sends an LPP message of type Provide Location Information to the E-SMLC before the Response Time provided in step (1) elapsed if step 1 occurred. If step 1 occurred and the UE is unable to perform the requested measurements, or if the Response Time provided in step 1 elapsed before any of the requested measurements have been obtained, the UE sends a LPP message of type Error instead, providing the error reason.

8.3.3.3.2 UE-initiated Position Measurement

Figure 8.3.3-4 shows the Position Measurement operations for the E-CID method when the procedure is initiated by the UE. This procedure may be used by the UE in case of basic self location for UE-assisted mode (i.e., UE requests its own location).

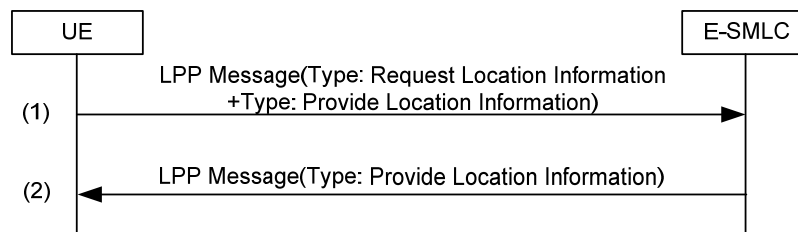

Figure 8.3.3-4: UE-initiated Position Measurement Procedure (Basic Self Location).

- (1) The UE sends a LPP message of type Request Location Information to the E-SMLC, including preferred location methods and quality of service parameters (accuracy and response time). The UE may also include an associated Provide Location Information message as described in step 2 of Figure 8.3.3-3 containing E-CID measurements and possibly other measurements. The Provide Location Information type may include any UE measurements already available at the UE and supported by the E-SMLC.
- (2) If the E-SMLC is able to calculate the UE position, it returns the location (possibly together with uncertainty information) to the UE in a LPP message of type Provide Location Information. If the E-SMLC cannot obtain the UE location, a LPP message of type Error is sent instead, providing the specific error reason.

8.3.4 Uplink E-CID Positioning Procedures

The procedures described in this subclause support E-CID related measurements obtained by the eNodeB and provided to the E-SMLC using LPPa. The term “uplink” is intended to indicate that from the E-SMLC point of view, the involved measurements are provided by the eNode B; this set of procedures might also be considered as “eNB-assisted E-CID”. An example of this uplink E-CID positioning method is AoA+T_{ADV}.

NOTE: Uplink E-CID positioning does not require LCS support in the UE and therefore, works also with legacy UEs (assuming that any involved measurements delivered in RRC are supported by the legacy UEs).

8.3.4.1 Position Capability Transfer Procedure

The position capability transfer procedure is not applicable to uplink E-CID positioning.

8.3.4.2 Assistance Data Delivery Procedure

The assistance data delivery procedure is not applicable to uplink E-CID positioning.

8.3.4.3 Position Measurement Procedure

The purpose of this procedure is to enable the E-SMLC to request position measurements from the eNode B.

Editor's Note: It is FFS whether an eNode B-initiated position measurement for uplink E-CID is supported.

8.3.4.3.1 E-SMLC-initiated Position Measurement

Figure 8.3.4-3 shows the Position Measurement operations for the uplink E-CID method when the procedure is initiated by the E-SMLC.

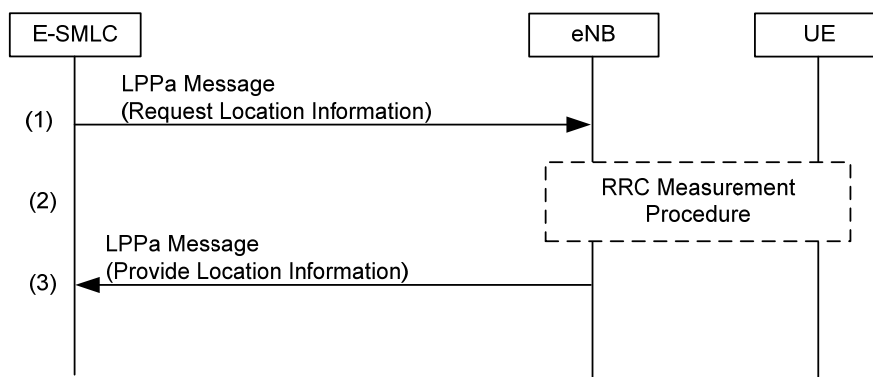

Figure 8.3.4-3: E-SMLC-initiated Position Measurement Procedure

- (1) The E-SMLC sends an LPPa message of type Request Location Information to the eNB. This request includes indication of E-CID measurements requested and required response time.
- (2) If the E-SMLC in step (1) requested UE measurements (i.e., E-UTRA carrier RSSI, RSRP, RSRQ measurements), or if the eNB requires UE measurements associated with the measurements requested by the E-SMLC (e.g., T_{ADV} type 1, which requires a UE Tx-Rx time difference measurement to be delivered from the UE to the eNB), the eNB may configure the UE to report the measurement information requested as specified in [14].
- (3) The eNode B obtains E-CID measurements as requested in step 1, and then sends an LPPa message of type Provide Location Information to the E-SMLC, before the response time provided in step 1 elapsed, and includes the obtained E-CID measurements. If the eNode B is unable to perform the requested measurements, or is unable to instigate required RRC procedures to obtain the requested measurements from the UE, or the response time elapsed before any of the requested measurements were obtained, the eNode B sends an LPPa message of type Error instead, providing the error reason.

8.4 Downlink Supporting Procedures

Editor's Note: It is FFS if LPPa is used to transfer assistance data for OTDOA as opposed to relying solely on other methods such as OAM. If LPPa is not used for this purpose this section would not be applicable.

8.4.1 General

An E-SMLC is enabled to request downlink location related information from the E-UTRAN in order to support downlink positioning. LPPa is employed for this between the E-SMLC and each eNodeB reachable from the E-SMLC via any of the MMEs with signalling access to the E-SMLC.

8.4.2 Location Related Information

The information that may be transferred from an eNodeB to the E-SMLC to support downlink positioning is listed in table 8.4.2-1.

Table 8.4.2-1: Information that may be transferred from an eNodeB to the E-SMLC for the Downlink Position Method Support

Information	UE-assisted	UE-based [FFS]
Global cell IDs (ECGIs) of eNodeB	Yes	Yes
Physical cell IDs (PCIs) of eNodeB	Yes	Yes
PRS Scheduling	Yes	Yes
If not GNSS synchronized: timing of other neighbor cells relative to eNB timing	Yes	Yes
If GNSS synchronized: timing association of eNB cells relative to GNSS	Yes	Yes

8.4.3 Location Related Information Acquisition Procedure

The purpose of this procedure is to enable an E-SMLC to request downlink location related information from an eNodeB.

8.4.3.1 On Demand Procedure

Figure 8.4.3-1 shows the location information acquisition operation for the downlink positioning method when information is needed on demand in real time.

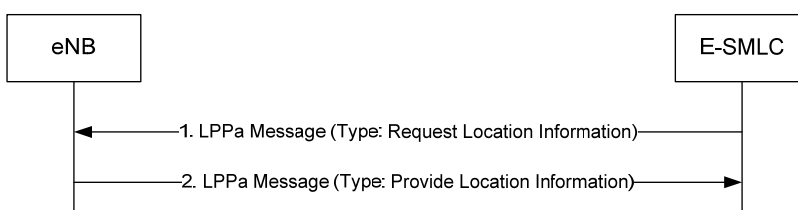

Figure 8.4.3-1: E-SMLC-initiated On Demand Procedure for Location Information Applicable to Downlink

- (1) The E-SMLC sends an LPPa message of type Request Location Information to the eNodeB. This request includes an indication of the downlink related information requested and a required response time.
- (2) The eNodeB obtains the information requested in step 1 using previously configured or stored information and/or real time measurements in the case of a request for timing information where recent timing information is not already available. The eNodeB then sends an LPPa message of type Provide Location Information to the E-SMLC, before the Response Time provided in step (1) elapsed. If the eNodeB is unable to obtain any of the requested information, or if the Response Time elapsed before any of the requested information could be obtained, the eNodeB sends an LPPa message of type Error instead, providing the error reason.

8.4.3.2 Triggered Procedure

Figure 8.4.3-2 shows the location information acquisition operation for the downlink positioning method when information is needed on a triggered basis.



Figure 8.4.3-2: E-SMLC-initiated Triggered Procedure for Location Information Applicable to Downlink

- (1) Optionally, the E-SMLC sends an LPPa message of type Request Location Information to the eNodeB. This request includes an indication of the downlink related information requested, triggering criteria for responses (e.g. periodic time interval and/or threshold change in a reported information item), a response time and criteria for terminating responses (e.g. a limit on the number of responses or a maximum reporting period).
- (2) Either in response to step 1 or based on configuration information, the eNodeB obtains the information requested in step 1 or defined by configuration using already available information and/or real time measurements. The eNodeB then sends an LPPa message of type Provide Location Information to the E-SMLC carrying this information, before the Response Time provided in step (1) elapsed if step 1 occurs. If the eNodeB is unable to obtain any of the requested information, or if the Response Time elapsed before any of the requested information could be obtained, the eNodeB sends an LPPa message of type Provide Location Information to the E-SMLC containing a cause indication and no location related information.
- (3) When the trigger criteria provided in step 1 or by configuration indicate the need for a new response (e.g. a periodic timer has expired or some timing difference has changed by more than a specified amount), the eNodeB obtains the latest information requested either in step 1 or by configuration. The eNodeB then sends a further LPPa message of type Provide Location Information to the E-SMLC containing this information, before the Response Time provided in step (1) or by configuration elapses following occurrence of the trigger. If the eNodeB is unable to obtain any of the requested information, or if the Response Time elapsed before any of the requested information could be obtained, the eNodeB sends an LPPa message of type Provide Location Information to the E-SMLC containing a cause indication and no location related information.
- (4) Step 3 is repeated for each further occurrence of the trigger(s) provided either in step 1 or by configuration until the criteria provided in step 1 or by configuration occur for cessation of reporting. This may or may not occur in conjunction with a reporting criterion. Regardless of which is the case, the eNodeB behaves as in step 3 to send a further LPPa message of type Provide Location Information to the E-SMLC. This message also carries an end of procedure indication.

Annex A (informative): Definitions and Terms

[FFS; intended for definitions and terminology more extensive than the acronym definitions.]

Annex B (informative): Use of LPP with SUPL

The design goal of LPP is to enable it to be used in user plane location solutions such as OMA SUPL ([17], [18]) and this informative annex shows how LPP can be used in SUPL 2.0.

B.1 SUPL 2.0 Positioning Methods and Positioning Protocols

The following table shows how the 3GPP positioning protocols are supported in SUPL 2.0.

Table B.1: SUPL support of positioning methods

Positioning Protocol:	RRLP (GSM/GPRS/WCDMA/ LTE/WLAN/WiMAX)	RRC (WCDMA)	LPP (LTE)
Positioning Method:			
A-GPS (A-GANSS) SET Assisted	✓	✓	✓
A-GPS (A-GANSS) SET Based	✓	✓	✓
Autonomous GPS/GANSS	✓	✓	✓
Enhanced Cell ID	✓	✓	✓
Enhanced Observed Time Difference (E-OTD)	✓ (GSM only)	NA	NA
Observed Time Difference of Arrival (OTDOA)	NA	✓	✓

Note: What is referred to in the SUPL specifications as “Enhanced Cell ID is a UE-Assisted positioning mode where the neighbouring cell measurements are carried at the SUPL layer (in the SUPL_POS_INIT for example). For LTE, the ASN.1 container for this mode is defined as follows:

```

LteCellInformation ::= SEQUENCE {
    refMCC  INTEGER(0..999), -- Mobile Country Code
    refMNC  INTEGER(0..999), -- Mobile Network Code
    refCI   BIT STRING(SIZE (29)), -- LTE Cell-Id including the CSG bit
    tA      INTEGER(0..255) OPTIONAL, -- Timing Advance as per 3GPP TS 36.321
    measResultListEUTRA  MeasResultListEUTRA OPTIONAL,
    ...}

MeasResultListEUTRA ::= SEQUENCE (SIZE (1..maxCellReport)) OF SEQUENCE {
    physicalCellIdentity  INTEGER(0..504),
    globalCellIdentity    BIT STRING(SIZE (29)) OPTIONAL, -- includes the
CSG bit
    earfcn-DL             INTEGER(0.. 32767), -- as per 3GPP TS 36.331
    measResultEUTRA      SEQUENCE {
    rsrpResult            INTEGER (0..97) OPTIONAL, -- as per 3GPP TS 36.331
    rsrqResult            INTEGER (0..33) OPTIONAL, -- as per 3GPP TS 36.331
    ...}
}

```

The IE "MeasResultListEUTRA" mirrors the equivalent IE from the RRC specification:

```

MeasResultEUTRA ::= SEQUENCE {
  physCellId          PhysCellId,
  cgi-Info            SEQUENCE {
    cellGlobalId      CellGlobalIdEUTRA,
    trackingAreaCode   TrackingAreaCode,
    plmn-IdentityList PLMN-IdentityList2 OPTIONAL
  } OPTIONAL,
  measResult         SEQUENCE {
    rsrpResult        RSRP-Range OPTIONAL,
    rsrqResult        RSRQ-Range OPTIONAL,
    ...
  }
}

```

It should be noted that in addition to the container provided by SUPL itself, any E-CID positioning methods defined within LPP proper can be supported in SUPL, via tunneling LPP as shown in this annex (in the same manner that A-GNSS and OTDOA are supported).

B.2 SUPL 2.0 and LTE Architecture

This section describes interworking between the control-plane LCS architecture, as defined in the main body of this specification, and SUPL 2.0. The E-SMLC either includes or has an interface to an SPC function as defined in OMA SUPL V2.0 ([17], [18]). It can thus provide a consistent set of positioning methods for deployments utilizing both control-plane and user-plane.

The interworking does not enable use of user-plane signalling for part of a control-plane positioning session. The user plane in the interworking here is not intended as an alternative path for control-plane signalling that would be needed between UE and eNodeB for mechanisms such as A-GPS in a standalone C-plane solution.

This interworking does enable the SPC to retrieve measurements (e.g., GNSS-to-RAN time relations) from eNodeB.

The underlying architecture is shown in Figur B.1. Note that, for interworking between user-plane and control-plane positioning, no new interfaces need to be defined as compared to those in the figure, assuming the SPC is either integrated in the E-SMLC or attached to it with a proprietary interface.

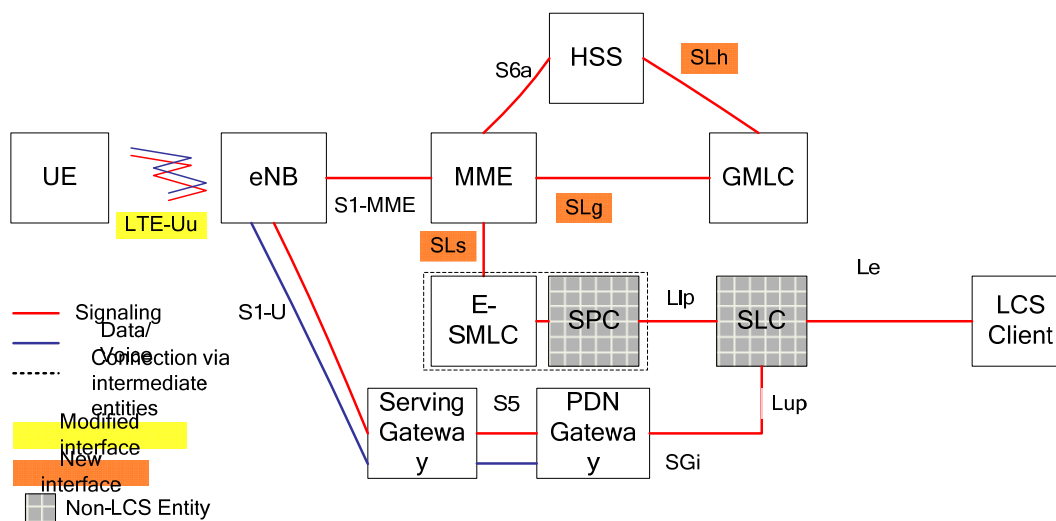

Figure B.1: System architecture underlying positioning

The Lup and Lp interfaces shown in this architecture are part of the user-plane solution only and are not required for control-plane positioning. The SLs interface is required for both control-plane and user-plane positioning, and needs to be capable of querying eNode Bs for information not related to a UE connection.

SUPL, including the use of LPP over SUPL, takes place as part of the general user-plane protocol stack shown in Figure B.2. SUPL occupies the application layer in the stack, with LPP (or another positioning protocol) transported as another layer above SUPL.

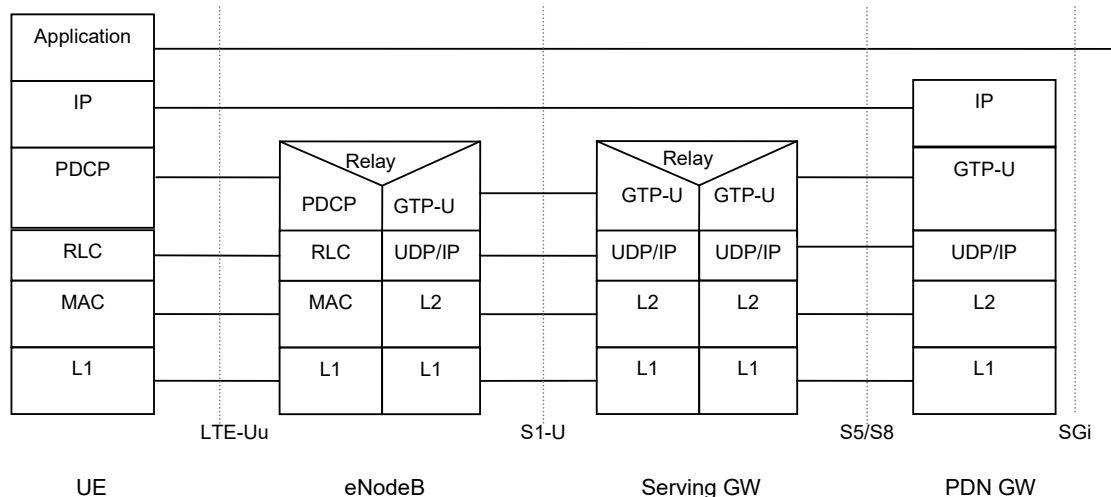

Figure B.2: User-plane protocol stack

B.3 LPP session procedures using SUPL

This section indicates how an LPP session relates to the SUPL structure. Figure B.3 shows how SUPL and LPP can be combined within a SUPL positioning session. Step 4 here is repeated to exchange multiple LPP messages between the SLP and SET.

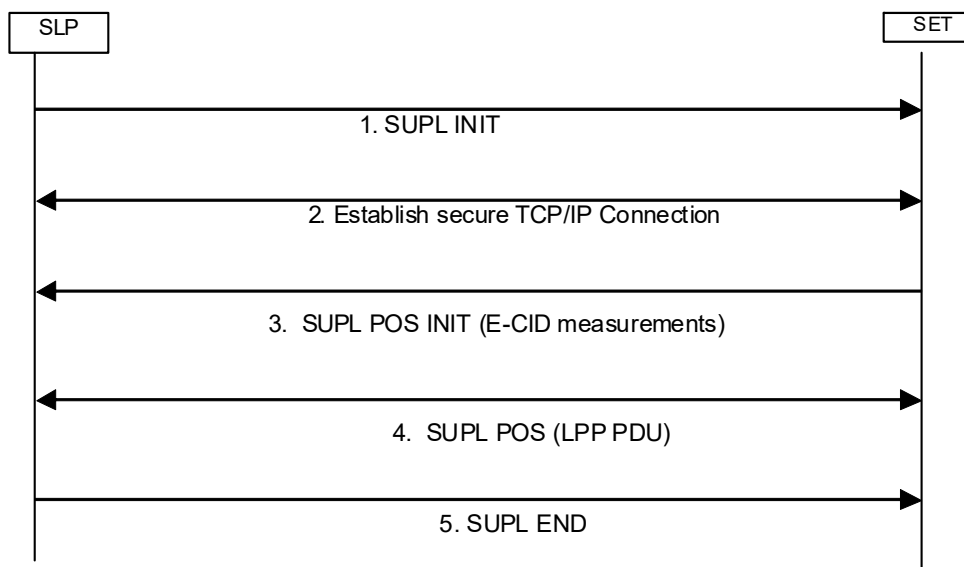

Figure B.3: LPP session over SUPL

For positioning operations which take place entirely within an LPP session (step 4 in Figure x.3), the flow of LPP messages can be the same as in the control-plane version of LPP; the role of the (LPP) target is taken by the target SET, and that of the (LPP) server by the SLP. An example LPP flow, including exchange of capabilities, request and delivery of assistance data, and request and delivery of positioning information, is shown in Figure B.4.

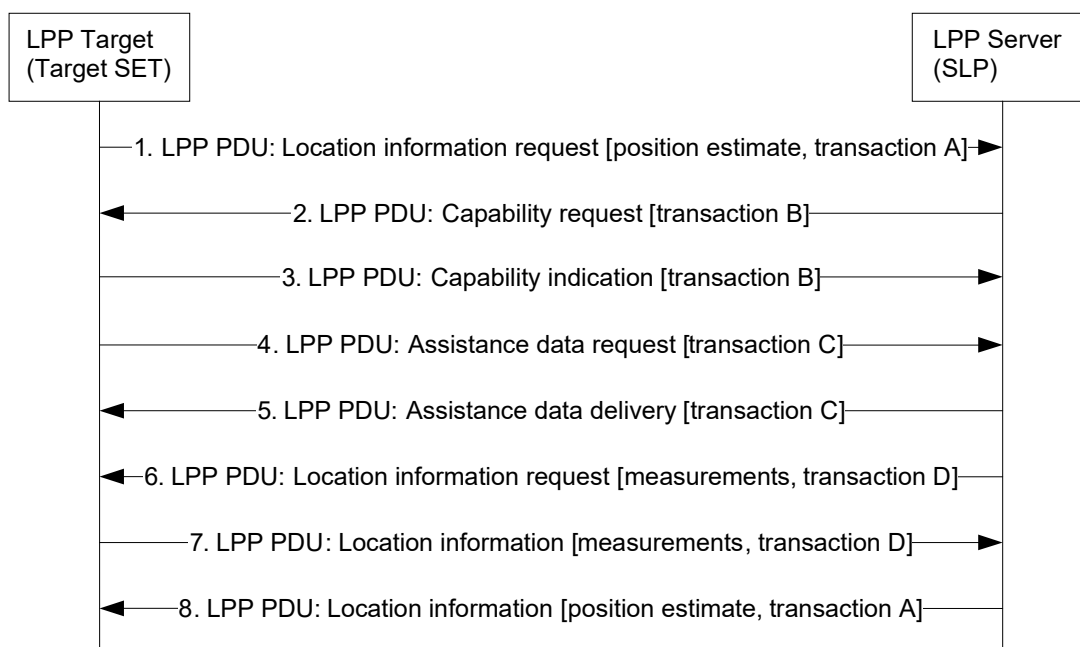

Figure B.4: LPP session over SUPL

B.4 Procedures combining C-plane and U-plane operations

Since SUPL is by definition carried over the user plane, it is not really applicable to operations terminating at the eNode B. Thus, in some cases where information from the eNode B and UE needs to be merged for a positioning operation, SUPL operations must take place in combination with control-plane procedures over LPPa.

This situation could arise in the case of UE-assisted OTDOA, for example, in which the SLP needs to provide the UE (in a SUPL session) with assistance data supplied by various eNode Bs. This section uses a UE-assisted OTDOA positioning operation as a running example.

Although the positioning server in this operation is of course the SLP, the existence of the Lp interface means that the SLP can communicate freely with the E-SMLC via the SPC. In particular, this means that assistance data that were delivered to the E-SMLC via LPPa can be transferred over to the SLP for delivery to the UE via LPP over SUPL.

Several ways to realise this general behaviour are possible. In the simplest case, the E-SMLC could be supplied with the necessary assistance data in advance, so that they can be supplied to the SLP without any actual LPPa procedures taking place in real time (and possibly even before the positioning transaction begins).

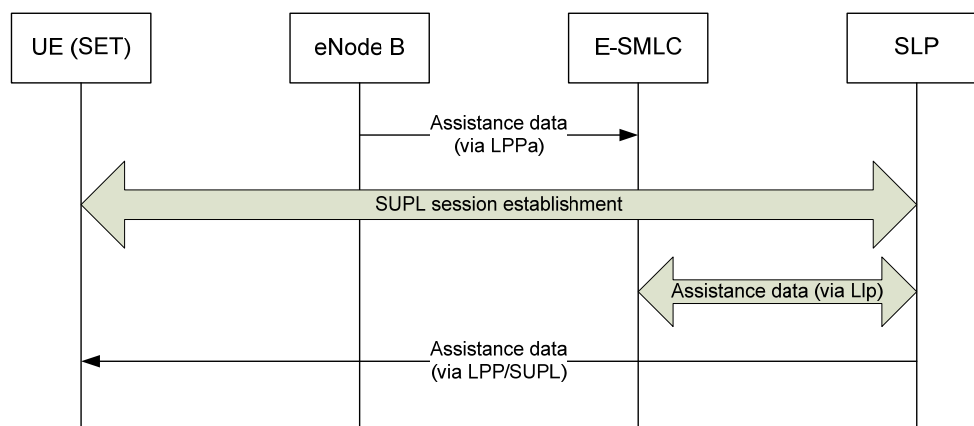

Figure B.5: Transfer of OTDOA assistance data to UE via SUPL

In the event that the E-SMLC does not have the required assistance data available, however, it would need to retrieve them from appropriate eNode Bs once it was made aware that they were needed.

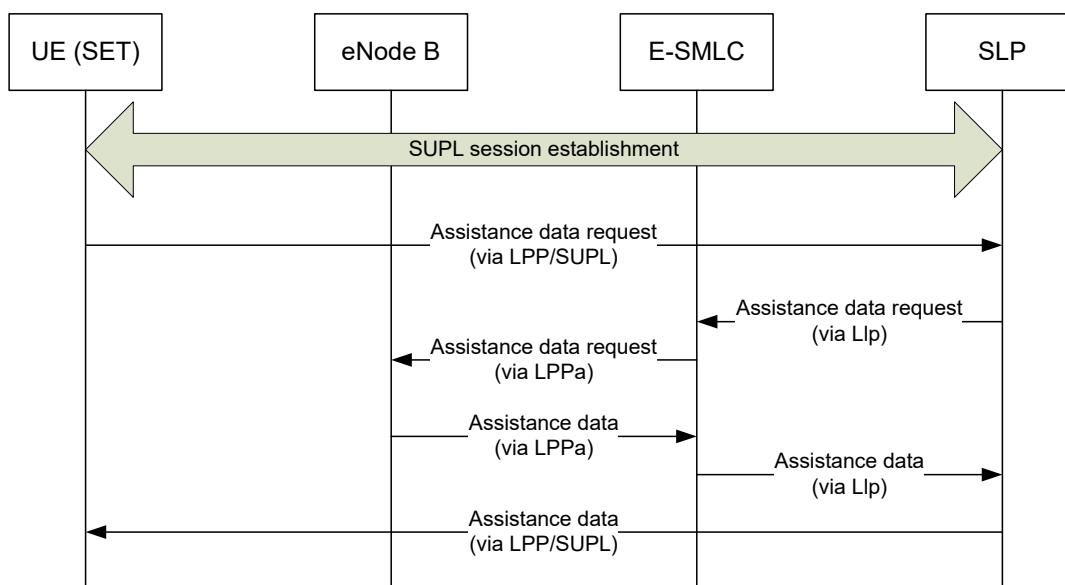

Figure B.6: Transfer to the UE via SUPL of OTDOA assistance data not already available at the E-SMLC

In both cases, it should be noted that the retrieval of the assistance data is transparent to the UE and to the actual SUPL session. This model is parallel to the approach used with A-GNSS, in which assistance data such as satellite ephemerides are retrieved from sources entirely external to the cellular network. For purposes of LPP over SUPL, the delivery of assistance data to the SLP can be looked on as an independent external process.

The delivery of assistance data to the UE, however, takes place through the same mechanisms as control-plane LPP, transported through SUPL.

Annex C (informative): Change history

Change history							
Date	TSG #	TSG Doc.	CR	Rev	Subject/Comment	Old	New
2009-05	RAN2#66	R2-092922	-	-	Skeleton TS v0.0.0		
2009-05	RAN2#66	R2-093522	-	-	RAN2 agreed skeleton TS v0.1.0		
2009-05	RAN2#66	R2-093589	-	-	RAN2 agreed TS v0.2.0		
2009-09	RAN2#67	R2-095377	-	-	RAN2 agreed TS v1.2.0		
2009-09	RAN #45	RP-090977	-	-	RAN approved TS 36.305	2.0.0	9.0.0