



US010872903B2

(12) **United States Patent**  
**Tang et al.**

(10) **Patent No.:** **US 10,872,903 B2**  
(45) **Date of Patent:** **Dec. 22, 2020**

(54) **THREE DIMENSIONAL MEMORY AND METHODS OF FORMING THE SAME**

(71) Applicant: **Micron Technology, Inc.**, Boise, ID (US)

(72) Inventors: **Sanh D. Tang**, Boise, ID (US); **John K. Zahurak**, Eagle, ID (US)

(73) Assignee: **Micron Technology, Inc.**, Boise, ID (US)

(\* ) Notice: Subject to any disclaimer, the term of this patent is extended or adjusted under 35 U.S.C. 154(b) by 0 days.

(21) Appl. No.: **16/716,177**

(22) Filed: **Dec. 16, 2019**

(65) **Prior Publication Data**  
US 2020/0119046 A1 Apr. 16, 2020

**Related U.S. Application Data**

(60) Continuation of application No. 16/125,242, filed on Sep. 7, 2018, now Pat. No. 10,510,769, which is a (Continued)

(51) **Int. Cl.**  
**H01L 27/11582** (2017.01)  
**H01L 27/11565** (2017.01)  
(Continued)

(52) **U.S. Cl.**  
CPC ..... **H01L 27/11582** (2013.01); **G11C 13/004** (2013.01); **G11C 13/0069** (2013.01);  
(Continued)

(58) **Field of Classification Search**  
CPC ... H01L 27/11517-27/1156; H01L 2924/1438; H01L 29/42324-29/42336;

(Continued)

(56) **References Cited**

**U.S. PATENT DOCUMENTS**

5,473,179 A 12/1995 Hong  
7,705,388 B2 4/2010 Iwata

(Continued)

**FOREIGN PATENT DOCUMENTS**

CN 101409290 A 4/2009  
CN 101483194 A 7/2009

(Continued)

**OTHER PUBLICATIONS**

US 8,546,864 B2, 10/2013, Tang et al. (withdrawn)  
(Continued)

*Primary Examiner* — Dale E Page  
*Assistant Examiner* — Wilner Jean Baptiste  
(74) *Attorney, Agent, or Firm* — Schwegman Lundberg & Woessner, P.A.

(57) **ABSTRACT**  
Some embodiments include a memory device and methods of forming the memory device. One such memory device includes a first group of memory cells, each of the memory cells of the first group being formed in a cavity of a first control gate located in one device level of the memory device. The memory device also includes a second group of memory cells, each of the memory cells of the second group being formed in a cavity of a second control gate located in another device level of the memory device. Additional apparatus and methods are described.

**20 Claims, 38 Drawing Sheets**

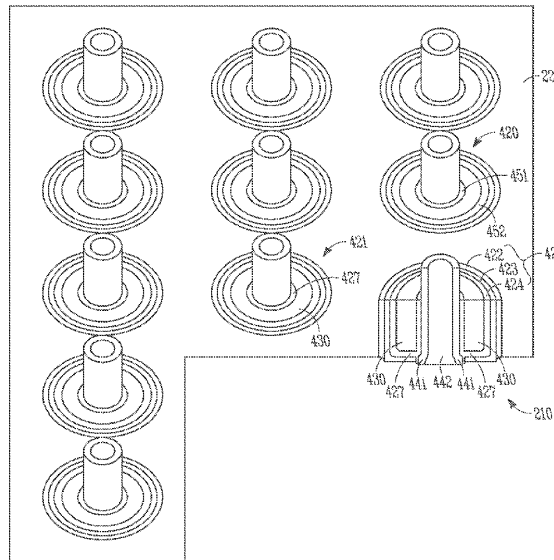

**Related U.S. Application Data**

continuation of application No. 15/722,580, filed on Oct. 2, 2017, now Pat. No. 10,090,324, which is a continuation of application No. 15/188,273, filed on Jun. 21, 2016, now Pat. No. 9,780,115, which is a continuation of application No. 14/041,928, filed on Sep. 30, 2013, now Pat. No. 9,379,005, which is a division of application No. 12/825,211, filed on Jun. 28, 2010, now Pat. No. 8,803,214.

(51) **Int. Cl.**

**H01L 23/528** (2006.01)  
**H01L 21/28** (2006.01)  
**H01L 27/06** (2006.01)  
**H01L 27/11551** (2017.01)  
**H01L 27/11556** (2017.01)  
**H01L 27/11578** (2017.01)  
**H01L 27/24** (2006.01)  
**H01L 29/66** (2006.01)  
**H01L 29/788** (2006.01)  
**H01L 29/792** (2006.01)  
**H01L 27/11548** (2017.01)  
**H01L 27/11575** (2017.01)  
**H01L 21/768** (2006.01)  
**GI1C 13/00** (2006.01)  
**GI1C 16/10** (2006.01)  
**GI1C 16/14** (2006.01)  
**GI1C 16/26** (2006.01)  
**H01L 27/11519** (2017.01)  
**H01L 45/00** (2006.01)

(52) **U.S. Cl.**

CPC ..... **GI1C 13/0097** (2013.01); **GI1C 16/10** (2013.01); **GI1C 16/14** (2013.01); **GI1C 16/26** (2013.01); **H01L 21/76838** (2013.01); **H01L 23/528** (2013.01); **H01L 27/0688** (2013.01); **H01L 27/11519** (2013.01); **H01L 27/11548** (2013.01); **H01L 27/11551** (2013.01); **H01L 27/11556** (2013.01); **H01L 27/11565** (2013.01); **H01L 27/11575** (2013.01); **H01L 27/11578** (2013.01); **H01L 27/249** (2013.01); **H01L 27/2454** (2013.01); **H01L 29/40114** (2019.08); **H01L 29/66825** (2013.01); **H01L 29/66833** (2013.01); **H01L 29/7889** (2013.01); **H01L 29/7926** (2013.01); **GI1C 2213/71** (2013.01); **H01L 45/06** (2013.01)

(58) **Field of Classification Search**

CPC ..... H01L 29/788-29/7889; H01L 27/11582; H01L 27/11519; H01L 23/528  
 See application file for complete search history.

(56) **References Cited**

U.S. PATENT DOCUMENTS

7,878,507 B1 2/2011 Dimond  
 7,906,818 B2 3/2011 Pekny  
 8,237,213 B2 8/2012 Lin  
 8,508,997 B2 8/2013 Tang et al.  
 8,759,895 B2 6/2014 Tang et al.  
 8,803,214 B2 8/2014 Tang et al.  
 9,093,370 B2 7/2015 Hwang  
 9,231,117 B2 1/2016 Tang et al.  
 9,379,005 B2 6/2016 Tang et al.  
 9,754,953 B2 9/2017 Tang et al.  
 9,780,115 B2\* 10/2017 Tang ..... GI1C 16/26  
 10,090,324 B2 10/2018 Tang et al.  
 10,510,769 B2 12/2019 Tang et al.  
 2002/0195668 A1 12/2002 Endoh et al.

2006/0277355 A1 12/2006 Ellsberry et al.  
 2007/0057310 A1 3/2007 Matsui et al.  
 2007/0136537 A1 6/2007 Doblar et al.  
 2007/0272973 A1 11/2007 Park et al.  
 2008/0048237 A1 2/2008 Iwata  
 2008/0153226 A1 6/2008 Mokhlesi  
 2008/0179659 A1 7/2008 Enda et al.  
 2008/0277720 A1 11/2008 Youn et al.  
 2009/0014858 A1 1/2009 Boon et al.  
 2009/0097321 A1 4/2009 Kim et al.  
 2009/0230454 A1 9/2009 Pekny  
 2009/0230458 A1 9/2009 Ishiduki et al.  
 2009/0267139 A1 10/2009 Maejima  
 2009/0283819 A1 11/2009 Ishikawa et al.  
 2009/0294828 A1 12/2009 Osawa et al.  
 2009/0294844 A1 12/2009 Tanaka et al.  
 2010/0003795 A1 1/2010 Park et al.  
 2010/0112769 A1 5/2010 Son et al.  
 2010/0181612 A1 7/2010 Kito et al.  
 2010/0240205 A1 9/2010 Son et al.  
 2010/0244119 A1 9/2010 Fukuzumi et al.  
 2010/0276743 A1 11/2010 Kuniya et al.  
 2010/0327340 A1 12/2010 Oota et al.  
 2011/0149656 A1 6/2011 Tang et al.  
 2011/0316063 A1 12/2011 Tang et al.  
 2012/0001250 A1 1/2012 Alsmeyer  
 2012/0217564 A1 8/2012 Tang et al.  
 2014/0030856 A1 1/2014 Tang et al.  
 2014/0302650 A1 10/2014 Tang et al.  
 2016/0118392 A1 4/2016 Tang et al.  
 2016/0300850 A1 10/2016 Tang et al.  
 2017/0365614 A1 12/2017 Tang et al.  
 2018/0047747 A1 2/2018 Tang et al.  
 2019/0006387 A1 1/2019 Tang et al.

FOREIGN PATENT DOCUMENTS

CN 101911287 A 12/2010  
 CN 103038882 A 4/2013  
 CN 103403861 A 11/2013  
 CN 103038882 B 10/2016  
 CN ZL201280010535.6 5/2017  
 EP 2586060 A2 5/2013  
 JP 06338602 A 12/1994  
 JP 10500790 A 1/1998  
 JP 2005353061 A 12/2005  
 JP 2007520826 A 7/2007  
 JP 2007318083 12/2007  
 JP 2008160004 A 7/2008  
 JP 2008171838 A 7/2008  
 JP 2010010688 1/2009  
 JP 2009093599 A 4/2009  
 JP 2009117843 5/2009  
 JP 2009117843 A 5/2009  
 JP 2009158775 A 7/2009  
 JP 2009224466 A 10/2009  
 JP 2009266945 A 11/2009  
 JP 2010102755 A 5/2010  
 JP 2010130016 A 6/2010  
 JP 2010147125 A 7/2010  
 JP 2010171185 A 8/2010  
 JP 2010225946 A 10/2010  
 JP 2011035228 A 2/2011  
 KR 100866966 B1 11/2008  
 KR 20090037690 A 4/2009  
 KR 1020100036520 A 4/2010  
 KR 20100053393 A 5/2010  
 KR 1020100053393 A 5/2010  
 KR 102005475 B1 7/2019  
 SG 10201505052 A 7/2015  
 SG 10201907425TA 9/2019  
 TW 201246396 A 11/2012  
 WO WO-2006132158 A1 12/2006  
 WO WO-2009084206 A1 7/2009  
 WO WO-2009114675 A2 9/2009  
 WO WO-2010018710 A1 2/2010  
 WO WO-2012009140 A2 1/2012  
 WO WO-2012116207 A1 5/2012  
 WO WO-2012116207 A2 8/2012

(56)

**References Cited**

## FOREIGN PATENT DOCUMENTS

## OTHER PUBLICATIONS

- U.S. Appl. No. 12/825,211 now U.S. Pat. No. 8,803,214, filed Jun. 28, 2010, Three Dimensional Memory and Methods of Forming the Same.
- U.S. Appl. No. 14/041,928 now U.S. Pat. No. 9,379,005, filed Sep. 30, 2013, Three Dimensional Memory and Methods of Forming the Same.
- U.S. Appl. No. 15/188,273 now U.S. Pat. No. 9,780,115, filed Jun. 21, 2016, Three Dimensional Memory and Methods of Forming the Same.
- U.S. Appl. No. 15/722,580 now U.S. Pat. No. 10,090,324, filed Oct. 2, 2017, Three Dimensional Memory and Methods of Forming the Same.
- U.S. Appl. No. 16/125,242 now U.S. Pat. No. 10,510,769, filed Sep. 7, 2018, Three Dimensional Memory and Methods of Forming the Same.
- U.S. Appl. No. 13/035,700 now U.S. Pat. No. 8,759,895, filed Feb. 25, 2011, Semiconductor Charge Storage Apparatus and Methods.
- U.S. Appl. No. 14/987,370 now U.S. Pat. No. 9,754,953, filed Jan. 4, 2016, Charge Storage Apparatus and Methods.
- U.S. Appl. No. 14/310,790 now U.S. Pat. No. 9,231,117, filed Jun. 20, 2014, Charge Storage Apparatus and Methods.
- U.S. Appl. No. 15/691,442, filed Aug. 30, 2017, Charge Storage Apparatus and Methods.
- “European Application Serial No. 11807258.6, Communication Pursuant to Article 94(3) EPC dated Oct. 7, 2019”, 4 pgs.
- “Korean Application Serial No. 10-2019-7021776, Notice of Preliminary Rejection dated Nov. 22, 2019”, w/ English Translation, 5 pgs.
- “Korean Application Serial No. 10-2019-7021776, Response filed Jan. 22, 2020 to Notice of Preliminary Rejection dated Nov. 22, 2019”, w/ English Claims, 16 pgs.
- “Chinese Application Serial No. 201180037212.1, Amendment filed Jun. 22, 2016”, w/English Translation, 11 pgs.
- “Chinese Application Serial No. 201180037212.1, Office Action dated Mar. 25, 2015”, W/English Translation, 18 pgs.
- “Chinese Application Serial No. 201180037212.1, Office Action dated Apr. 29, 2016”, w/English Translation, 5 pgs.
- “Chinese Application Serial No. 201180037212.1, Office Action dated Nov. 25, 2015”, w/English Translation, 9 pgs.
- “Chinese Application Serial No. 201180037212.1, Response filed Feb. 3, 2016 to Office Action dated Nov. 25, 2015”, w/English Claims, 85 pgs.
- “Chinese Application Serial No. 201180037212.1, Response filed May 31, 2016 to Office Action dated Apr. 29, 2016”, w/English Claims, 28 pgs.
- “Chinese Application Serial No. 201180037212.1, Response filed Aug. 7, 2015 to Office Action dated Mar. 25, 2015”, W/ English Claims, 23 pgs.
- “Chinese Application Serial No. 201280010535.6, Office Action dated Jun. 28, 2016”, W/English Translation, 15 pgs.
- “Chinese Application Serial No. 201280010535.6, Office Action dated Oct. 10, 2015”, W/English Translation, 25 pgs.
- “Chinese Application Serial No. 201280010535.6, Response filed Feb. 24, 2016 to Office Action dated Oct. 10, 2015”, W/ English Claims, 20 pgs.
- “Chinese Application Serial No. 201280010535.6, Response filed Nov. 11, 2016 to Office Action dated Jun. 28, 2016”, w/English Claims, 20 pgs.
- “Chinese Application Serial No. 201280010535.6, Response filed Dec. 20, 2016 to Office Action dated Jun. 28, 2016”, W/ English Translation of Claims, 16 pgs.
- “European Application Serial No. 11807258.6, European Search Report dated Apr. 15, 2015”, 6 pgs.
- “European Application Serial No. 11807258.6, Extended European Search Report dated Jul. 15, 2015”, 13 pgs.
- “European Application Serial No. 11807258.6, Response filed Feb. 10, 2016 to Extended European Search Report dated Jul. 15, 2015”, 21 pgs.
- “European Application Serial No. 12749034.0, Extended European Search Report dated Dec. 1, 2016”, 9 pgs.
- “European Application Serial No. 12749034.0, Partial Supplementary European Search Report dated Aug. 31, 2016”, 7 pgs.
- “International Application Serial No. PCT/US2011/041888, International Preliminary Report on Patentability dated Jan. 10, 2013”, 9 pgs.
- “International Application Serial No. PCT/US2011/041888, Search Report dated May 1, 2012”, 4 pgs.
- “International Application Serial No. PCT/US2011/041888, Written Opinion dated May 1, 2012”, 6 pgs.
- “International Application Serial No. PCT/US2012/026358, International Preliminary Report on Patentability dated Sep. 6, 2013”, 5 pgs.
- “International Application Serial No. PCT/US2012/026358, Search Report dated Oct. 4, 2012”, 3 pgs.
- “International Application Serial No. PCT/US2012/026358, Written Opinion dated Oct. 4, 2012”, 3 pgs.
- “Japanese Application Serial No. 2013-518511 Response filed Feb. 25, 2015 to Office Action dated Jul. 29, 2014”, With the English claims, 11 pgs.
- “Japanese Application Serial No. 2013-518511, Office Action dated Mar. 24, 2015”, W/ English Translation, 4 pgs.
- “Japanese Application Serial No. 2013-518511, Office Action dated Jul. 29, 2014”, W/ English Translation, 11 pgs.
- “Japanese Application Serial No. 2013-518511, Office Action dated Dec. 2, 2014”, W/ English Translation, (Dec. 2, 2014), 4 pgs.
- “Japanese Application Serial No. 2013-518511, Response filed Oct. 29, 2014 to Office Action dated Jul. 29, 2014”, W/ English Claims, 25 pgs.
- “Japanese Application Serial No. 2013-555567, Amendment filed Feb. 10, 2015”, W/ Machine Translation of Claims, 11 pgs.
- “Japanese Application Serial No. 2013-555567, Office Action dated Mar. 17, 2015”, W/ English Translation, 6 pgs.
- “Japanese Application Serial No. 2013-555567, Response filed Dec. 10, 2015 to Office Action dated Mar. 17, 2015”, W/ English Claims, 8 pgs.
- “Japanese Application Serial No. 2015-83308, Office Action dated Dec. 22, 2015”, w/English Translation, 21 pgs.
- “Japanese Application Serial No. 2015-83308, Response filed Mar. 17, 2016 to Office Action dated Dec. 22, 2015”, w/English Claims, 7 pgs.
- “Korean Application Serial No. 10-2013-7001962, Notice of Preliminary Rejection dated Mar. 30, 2018”, w/ English Translation, 9 pgs.
- “Korean Application Serial No. 10-2013-7001962, Notice of Preliminary Rejection dated Aug. 30, 2017”, With English Translation, 6 pgs.
- “Korean Application Serial No. 10-2013-7001962, Notice of Preliminary Rejection dated Nov. 30, 2018”, W/ English Translation, 9 pgs.
- “Korean Application Serial No. 10-2013-7001962, Response Filed Jan. 31, 2019 to Notice of Preliminary Rejection dated Nov. 30, 2018”, w/English Claims, 14 pgs.
- “Korean Application Serial No. 10-2013-7001962, Response filed Jun. 29, 2018 to Notice of Preliminary Rejection dated Mar. 30, 2018”, w/ English Claims, 16 pgs.
- “Korean Application Serial No. 10-2013-7001962, Response filed Oct. 30, 2017 to Notice of Preliminary Rejection dated Aug. 30, 2017”, w/English Claims, 17 pgs.
- “Korean Application Serial No. 10-2013-7025314 Response filed Jun. 16, 2015 to Office Action dated May 21, 2015”, W/ English Claims, 22 pgs.
- “Korean Application Serial No. 10-2013-7025314, Amendment filed May 15, 2015”, W/ English Claims, 31 pgs.
- “Korean Application Serial No. 10-2013-7025314, Office Action filed May 21, 2015”, W/ English Translation, 7 pgs.
- “Taiwanese Application Serial No. 101105342, Amendment filed Feb. 13, 2015”, W/ English Claims, 7 pgs.

(56)

**References Cited**

OTHER PUBLICATIONS

“Taiwanese Application Serial No. 101105342, Office Action dated Apr. 28, 2015”, W/ English Translation, 6 pgs.

“Taiwanese Application Serial No. 101105342, Response filed Jul. 24, 2015 to Office Action dated Apr. 28, 2015”, W/ English Claims, 10 pgs.

Kim, Jiyoung, et al., “Novel 3-D structure for ultra high density flash memory with VRAT (Vertical-Recess-Array-Transistor) and PIPE (Planarized Integration on the same PlanE)”, 2008 Symposium on VLSI Technology, (Jun. 17-19, 2008), 122-23.

Komori, Yosuke, et al., “Disturbless Flash Memory due to High Boost Efficiency on BiCS Structure and Optimal Memory Film Stack for Ultra High Density Storage Device”, International Electron Devices Meeting Technical Digest, (Dec. 2008), 851-854.

Tanaka, H., et al., “Bit Cost Scalable Technology with Punch and Plug Process for Ultra High Density Flash Memory”, IEEE Symposium on VLSI Technology, (2007), 14-15.

\* cited by examiner

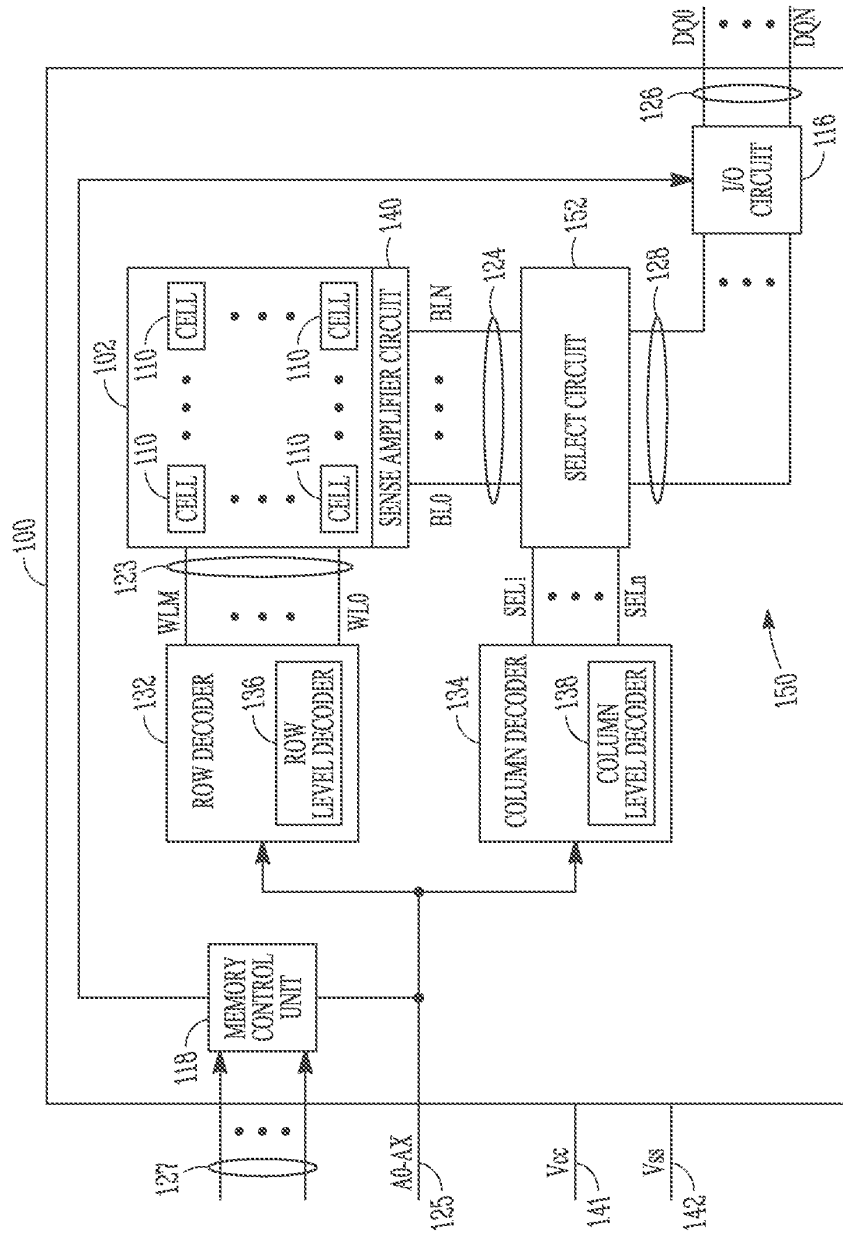

FIG. 1

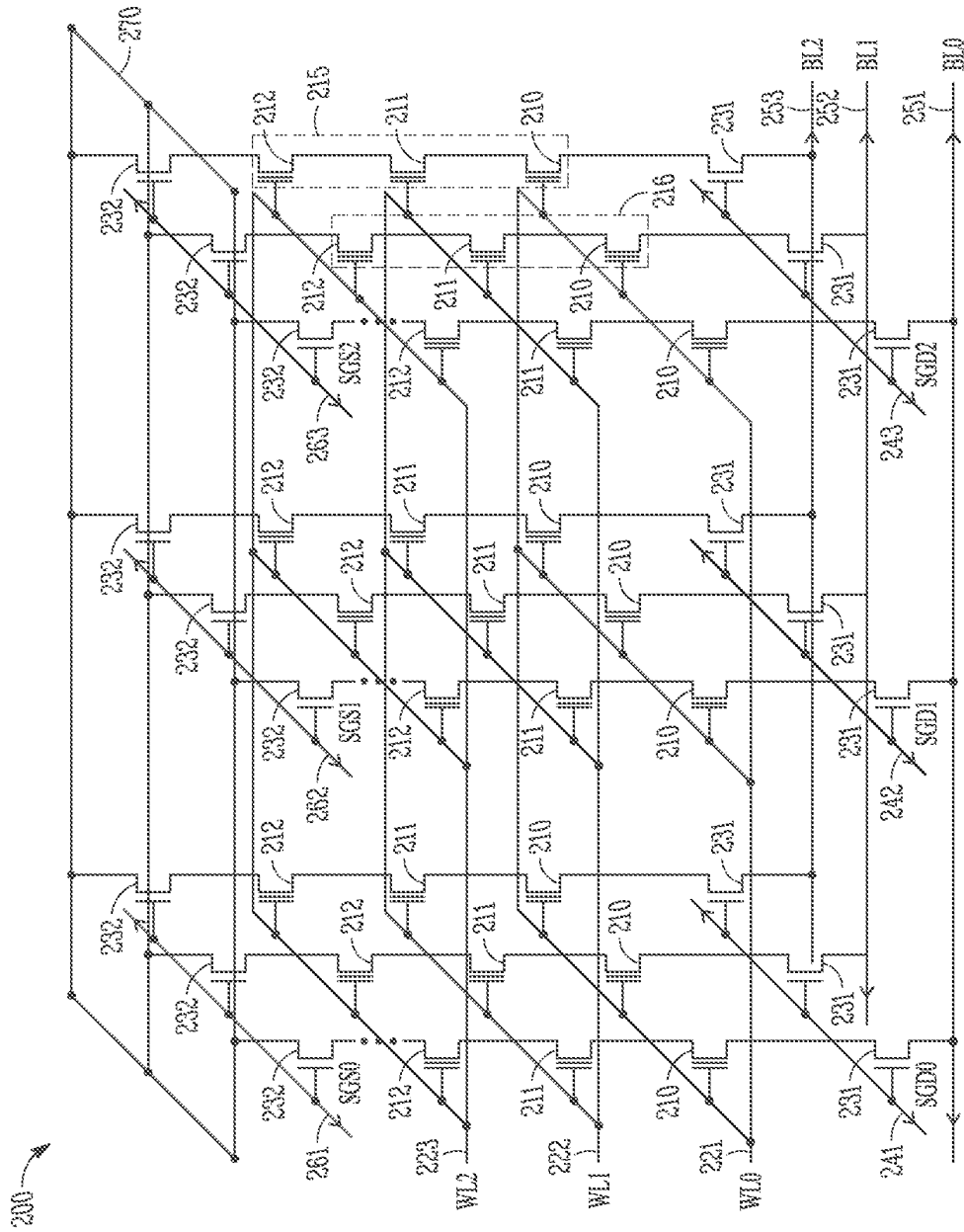

FIG. 2

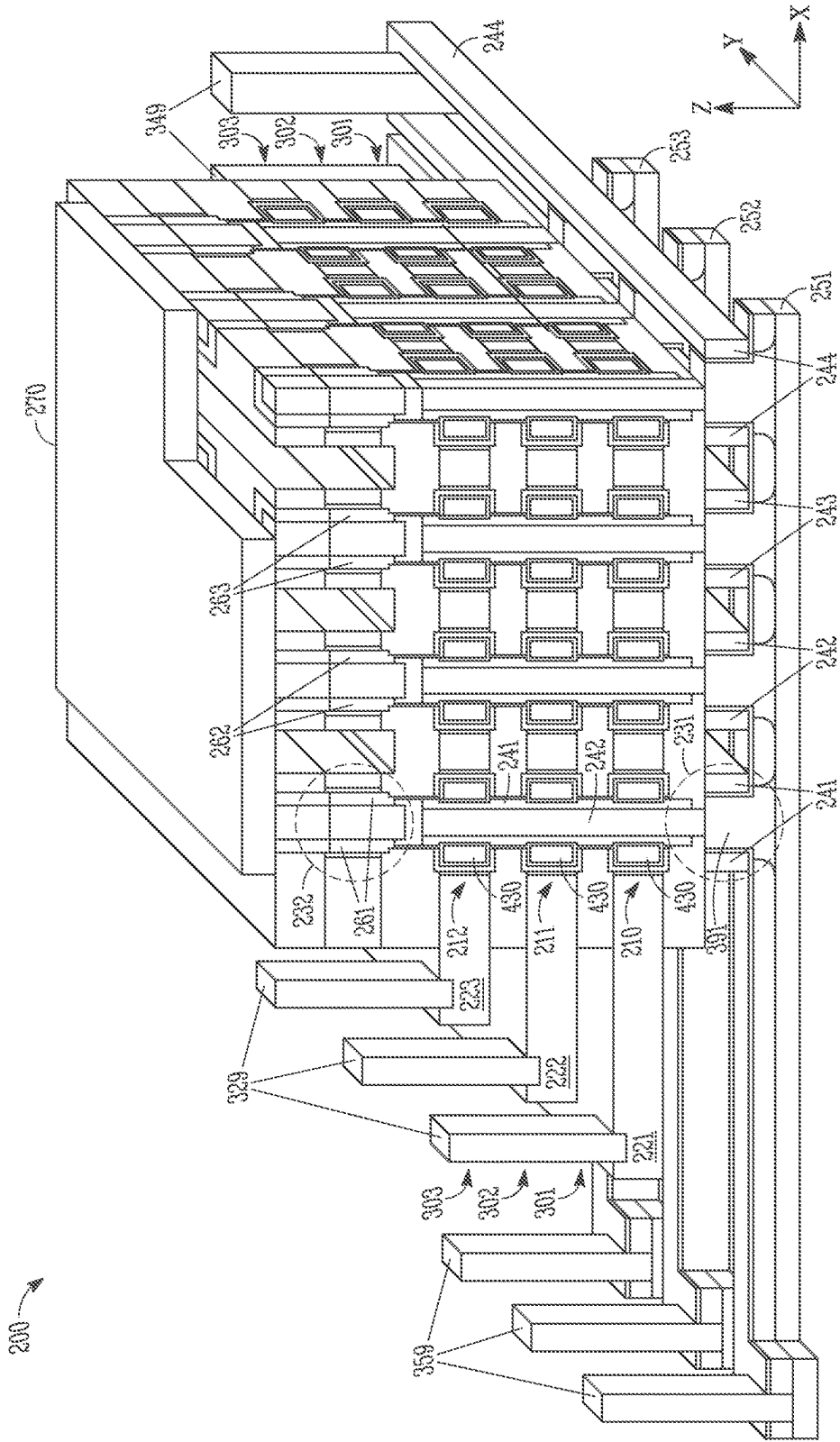

FIG. 3



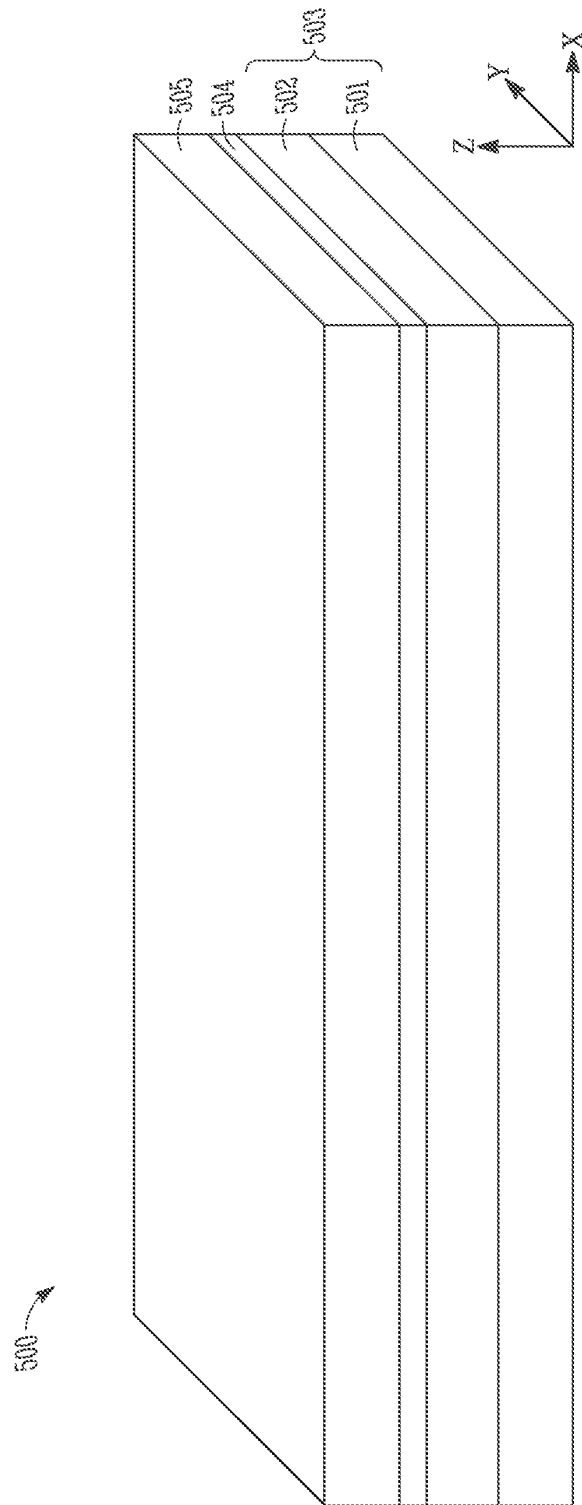

FIG. 5

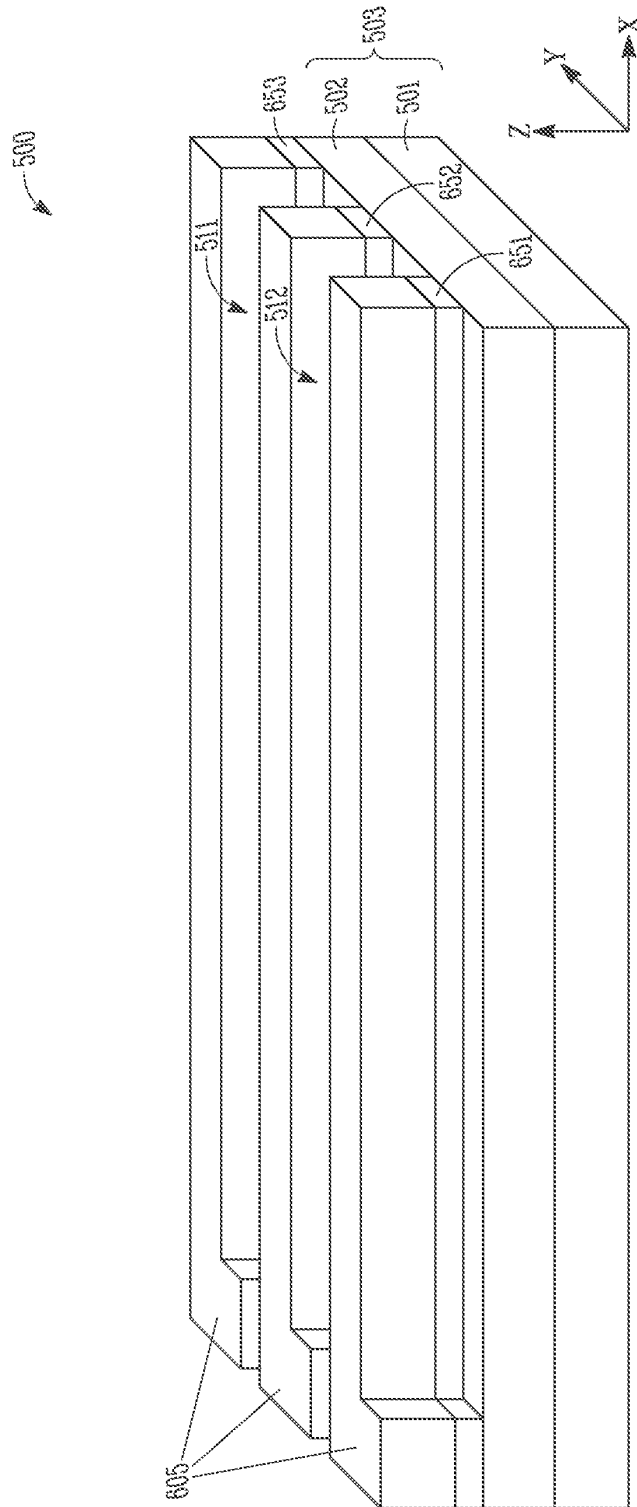

FIG. 6

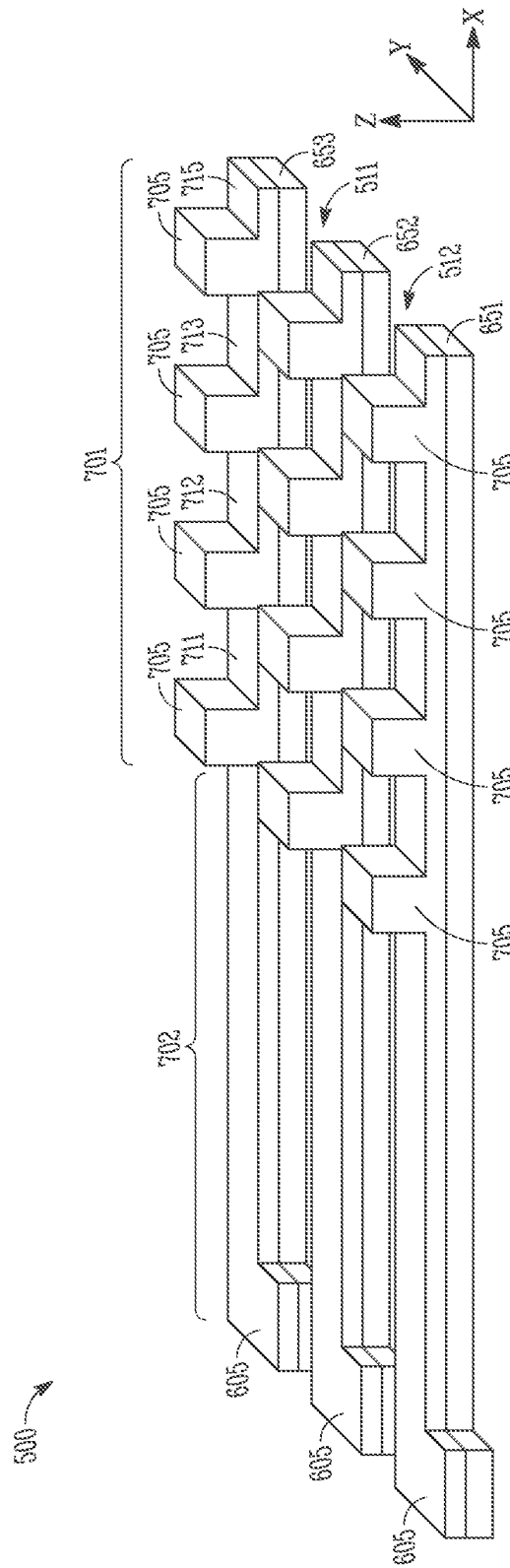

FIG. 7

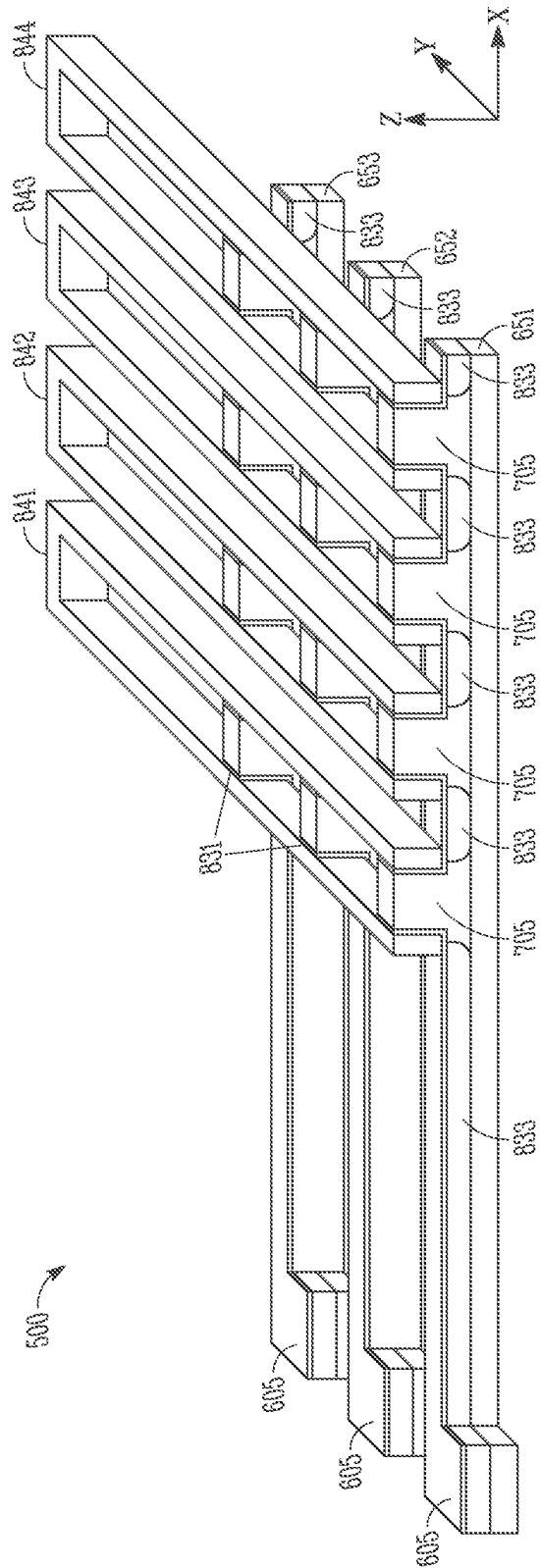

FIG. 8

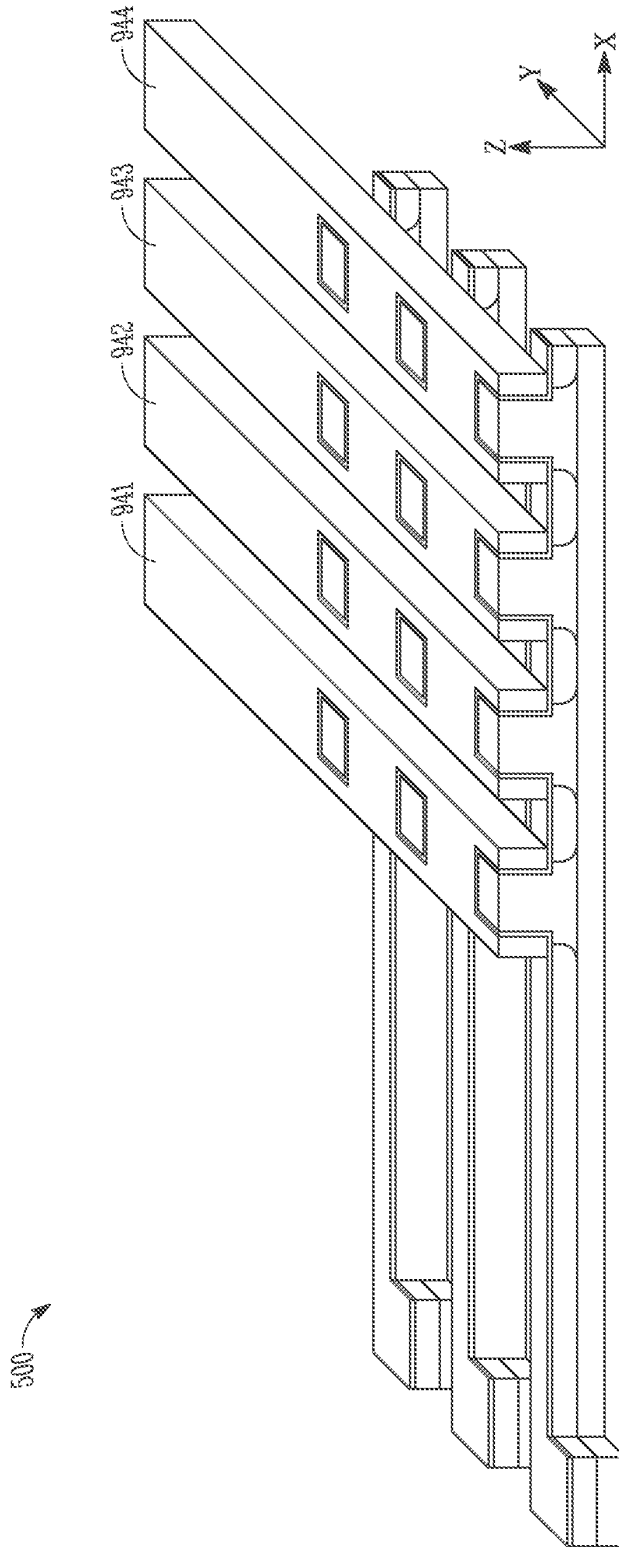

FIG. 9

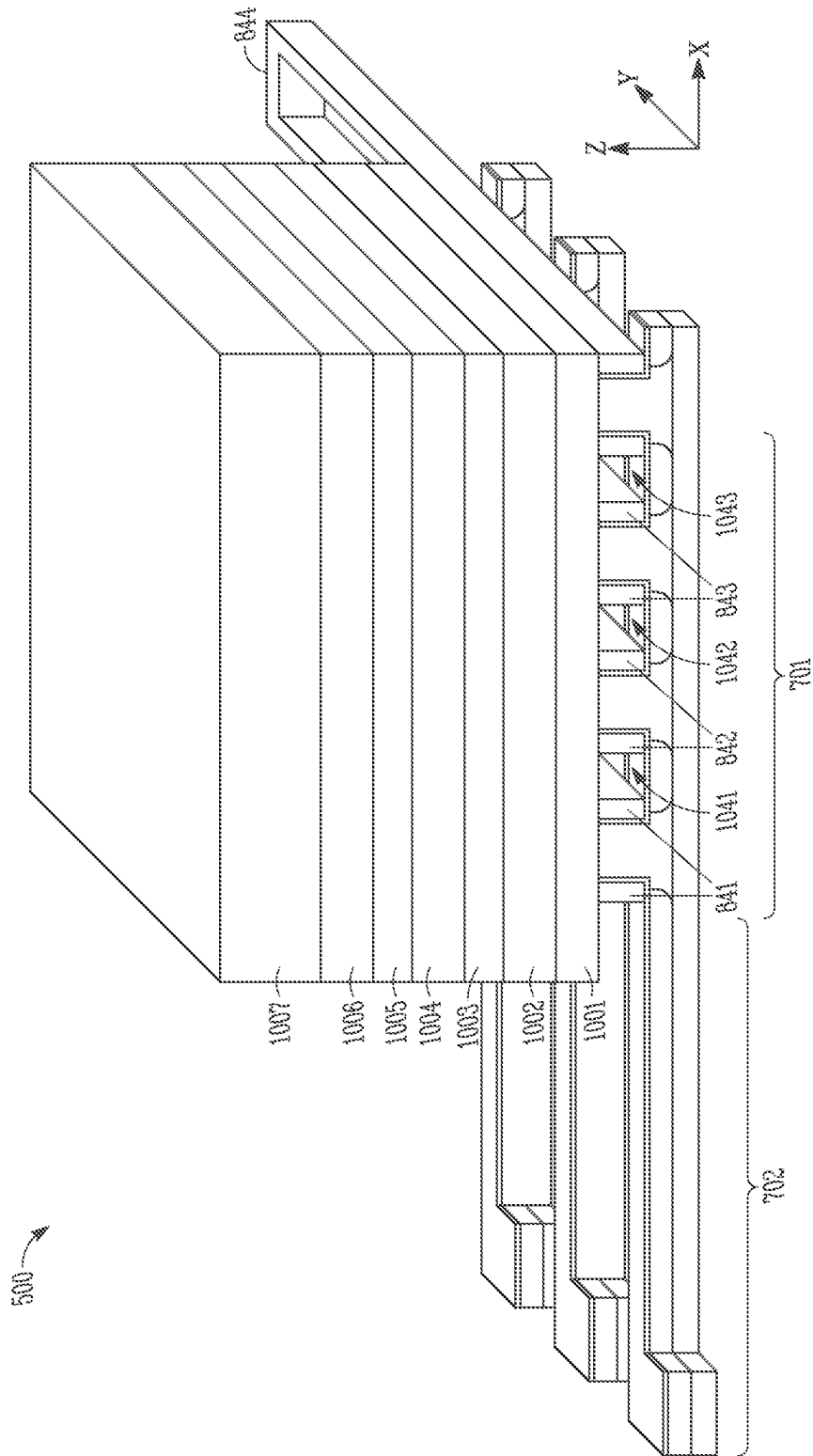

FIG. 10

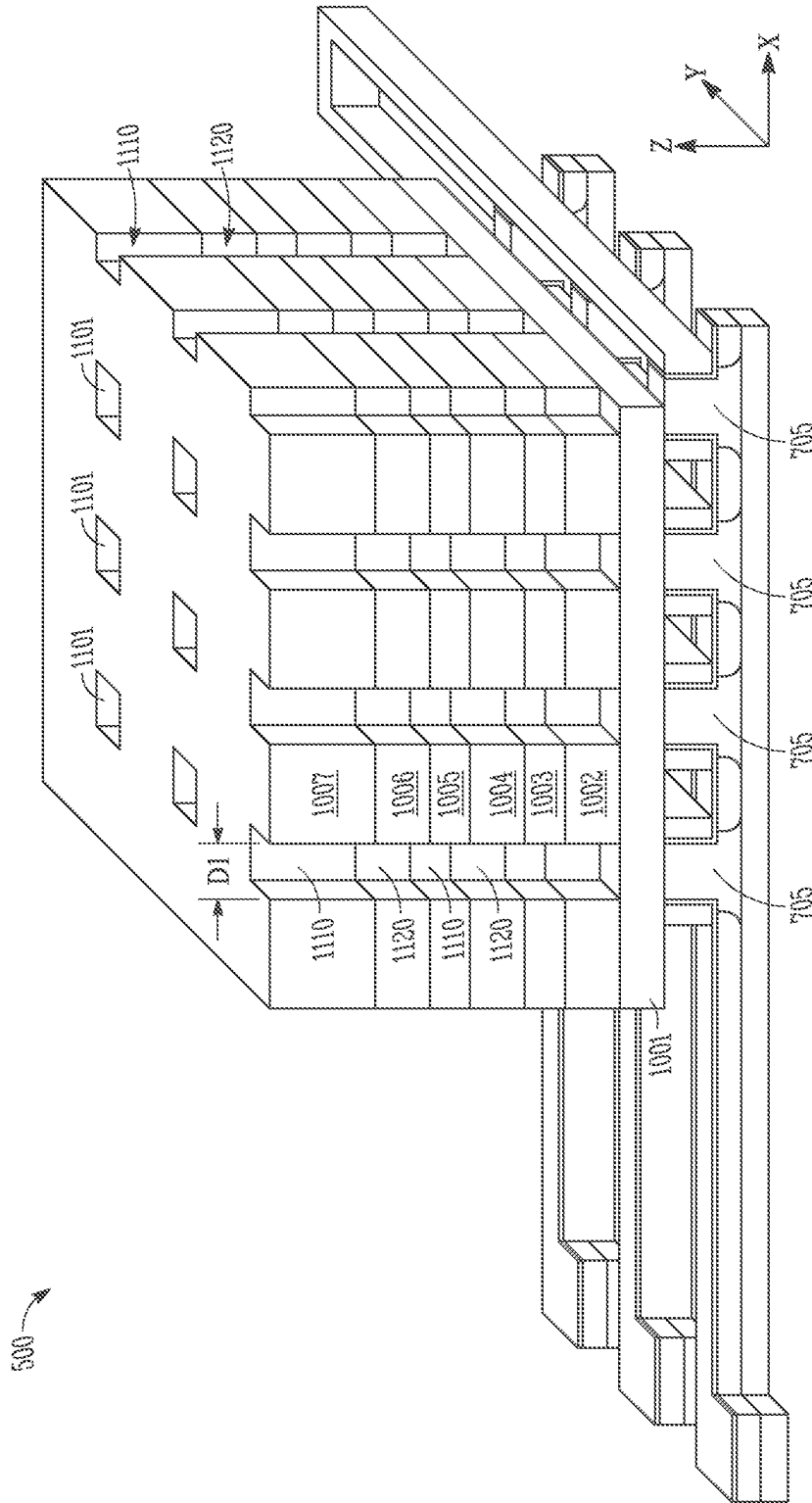

FIG. 11



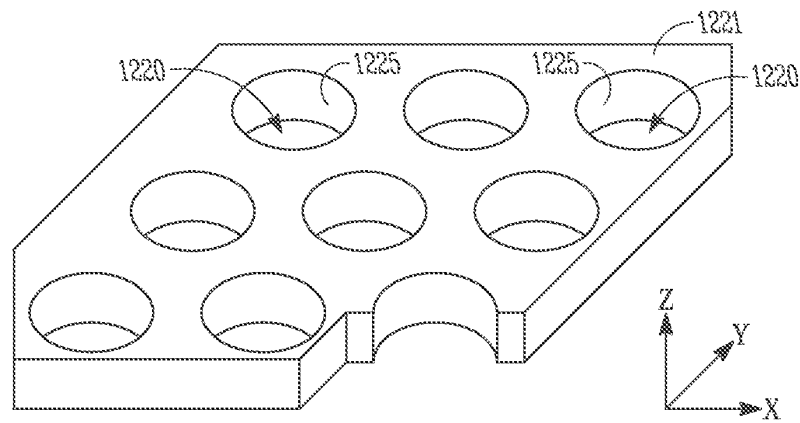

FIG. 13

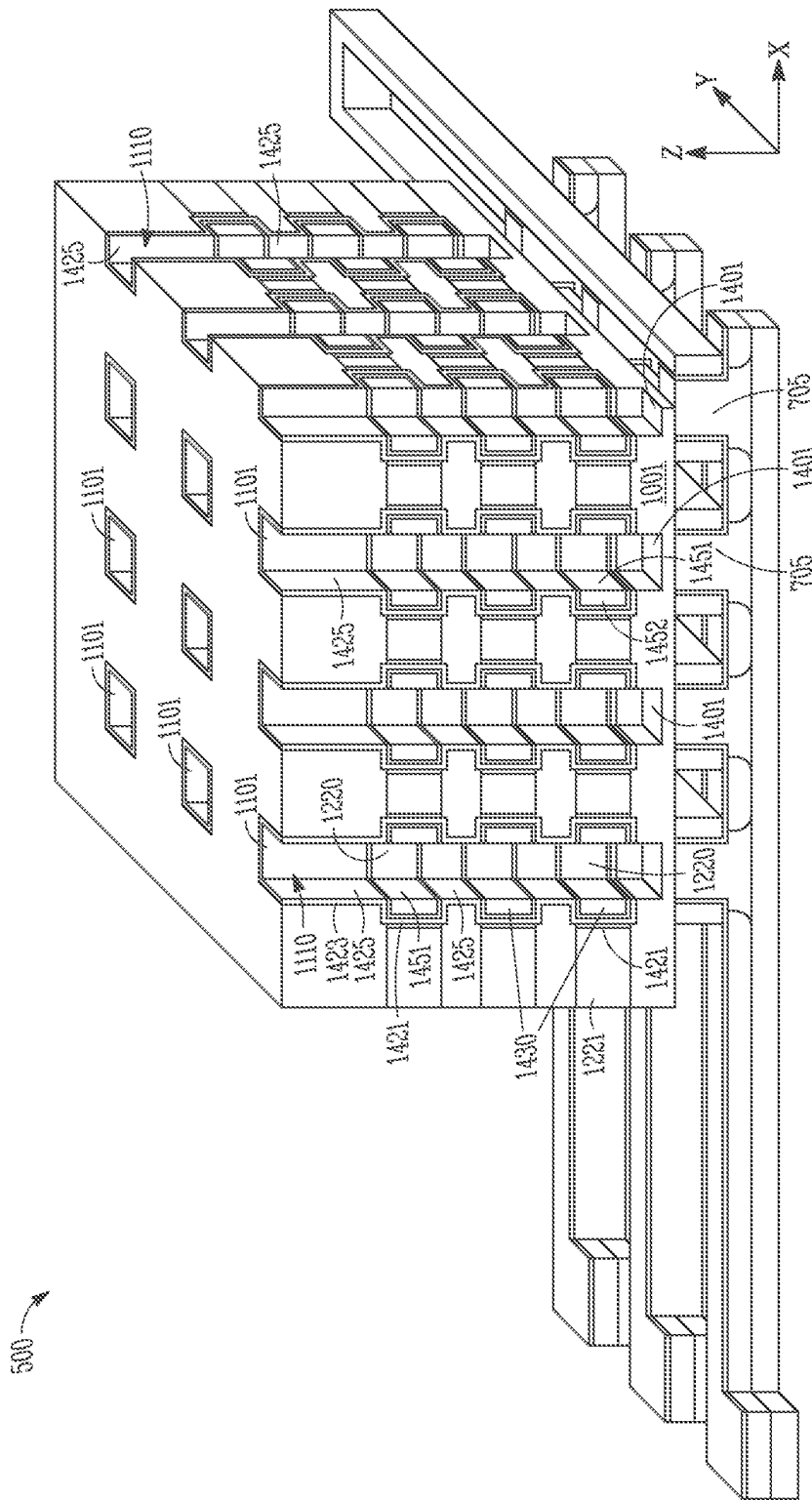
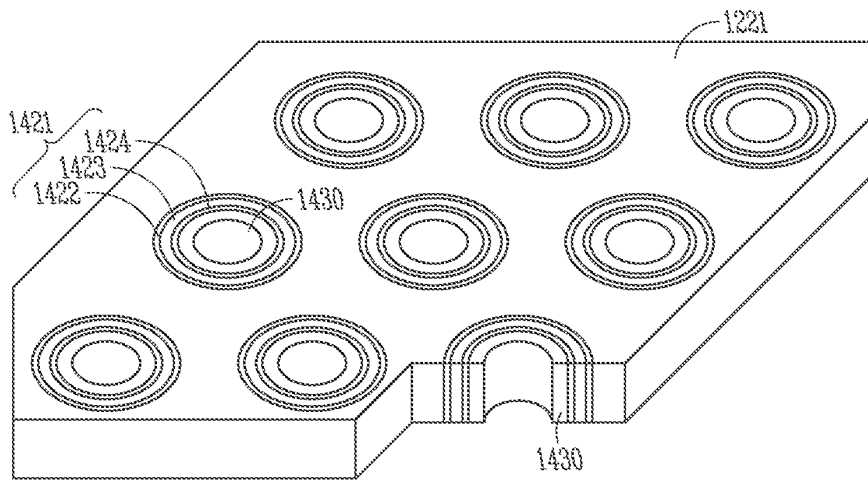

FIG. 14



*FIG. 15*

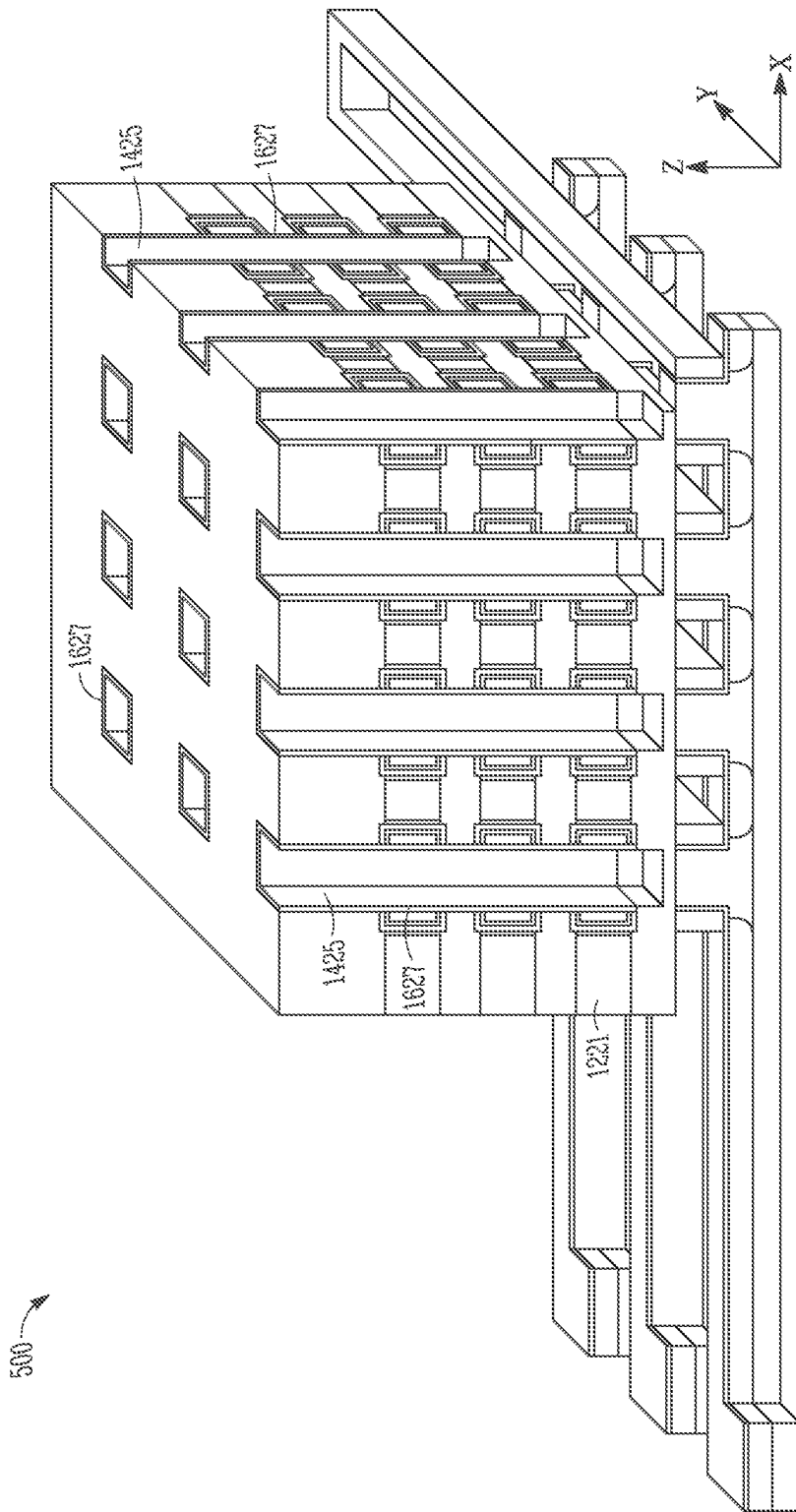
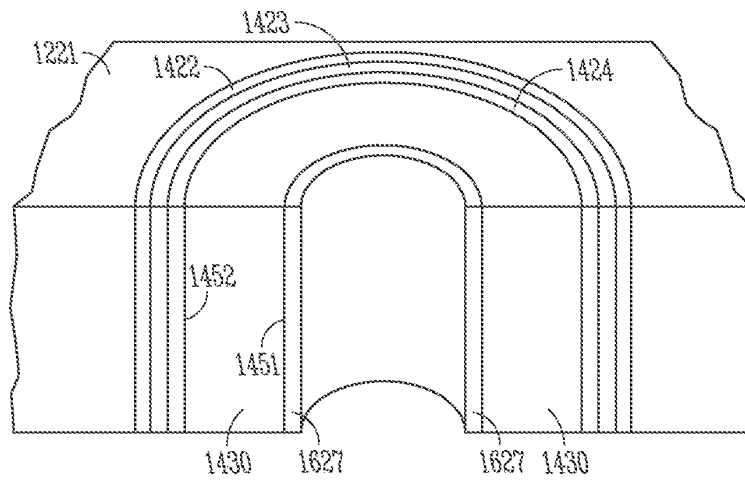

FIG. 16



*FIG. 17*

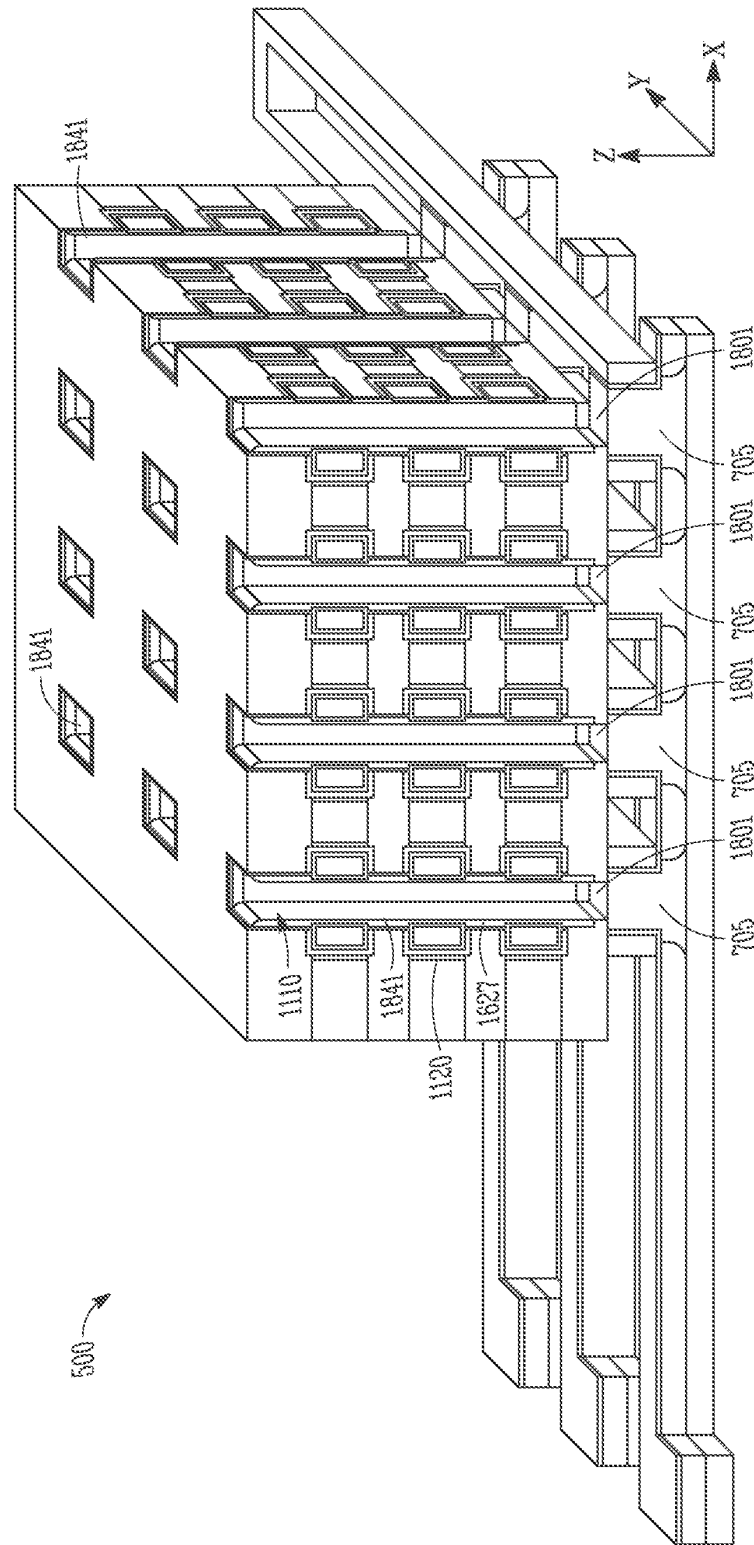
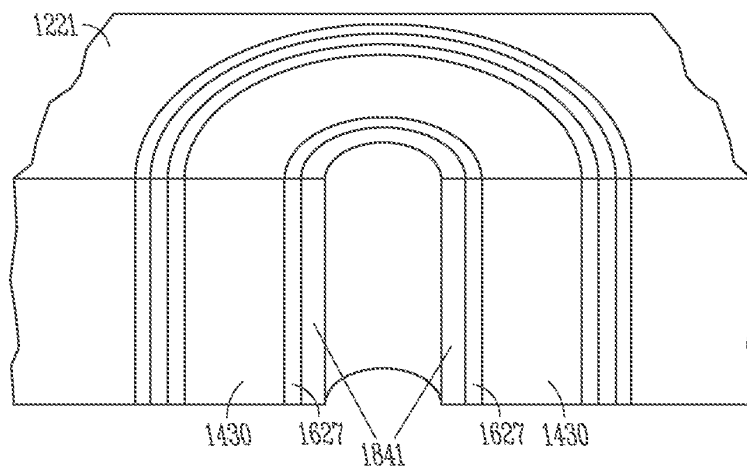

FIG. 18



*FIG. 19*

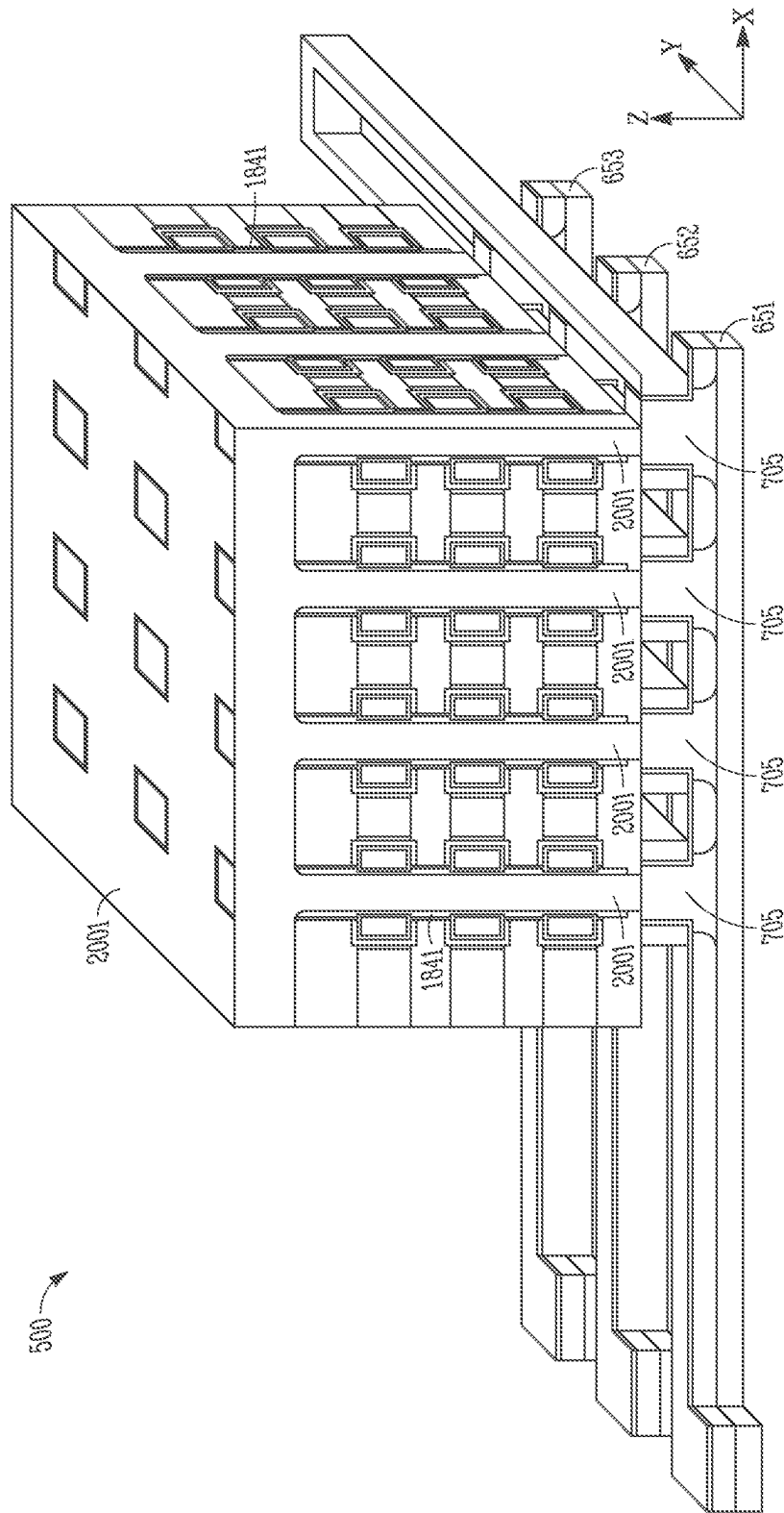

FIG. 20

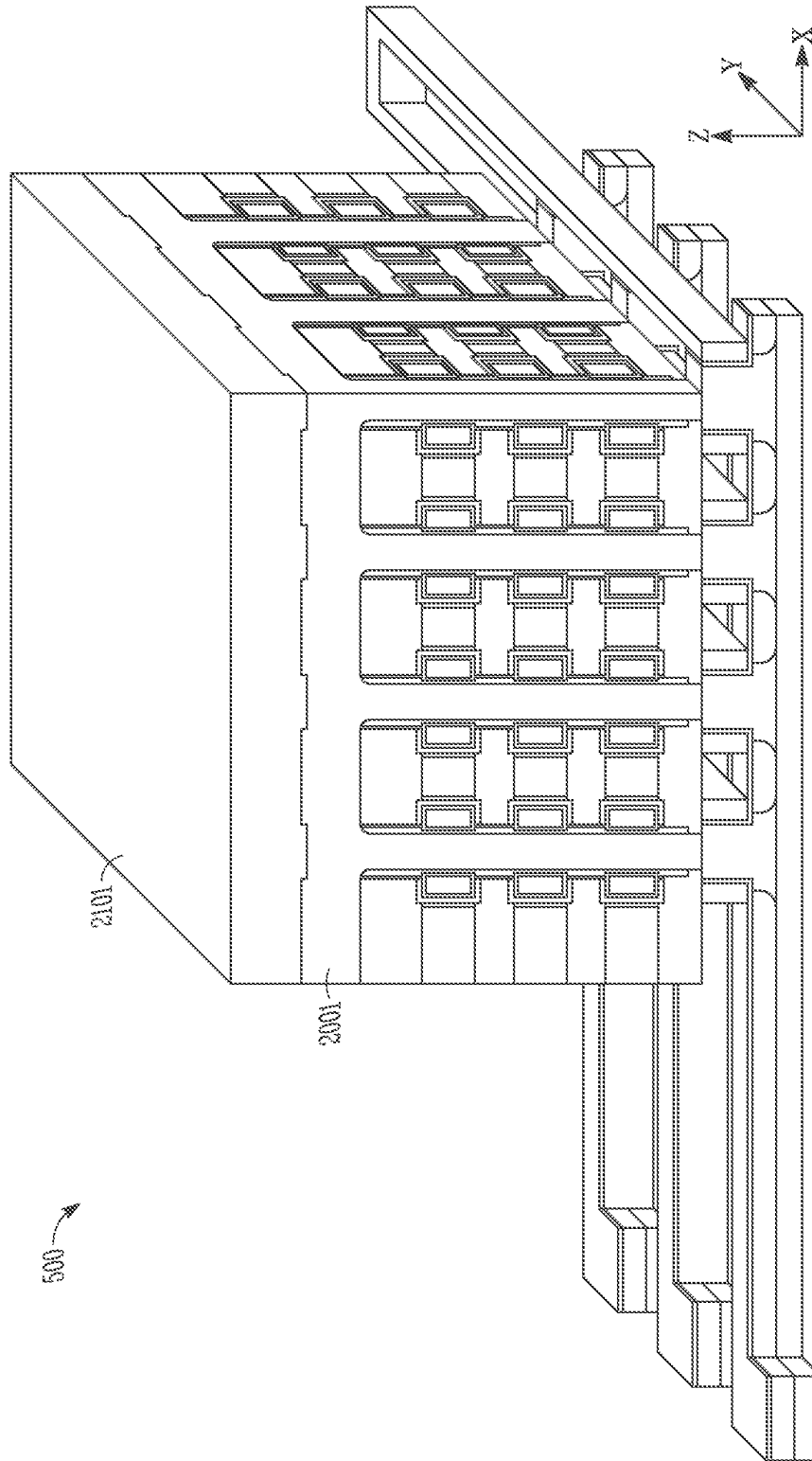

FIG. 21

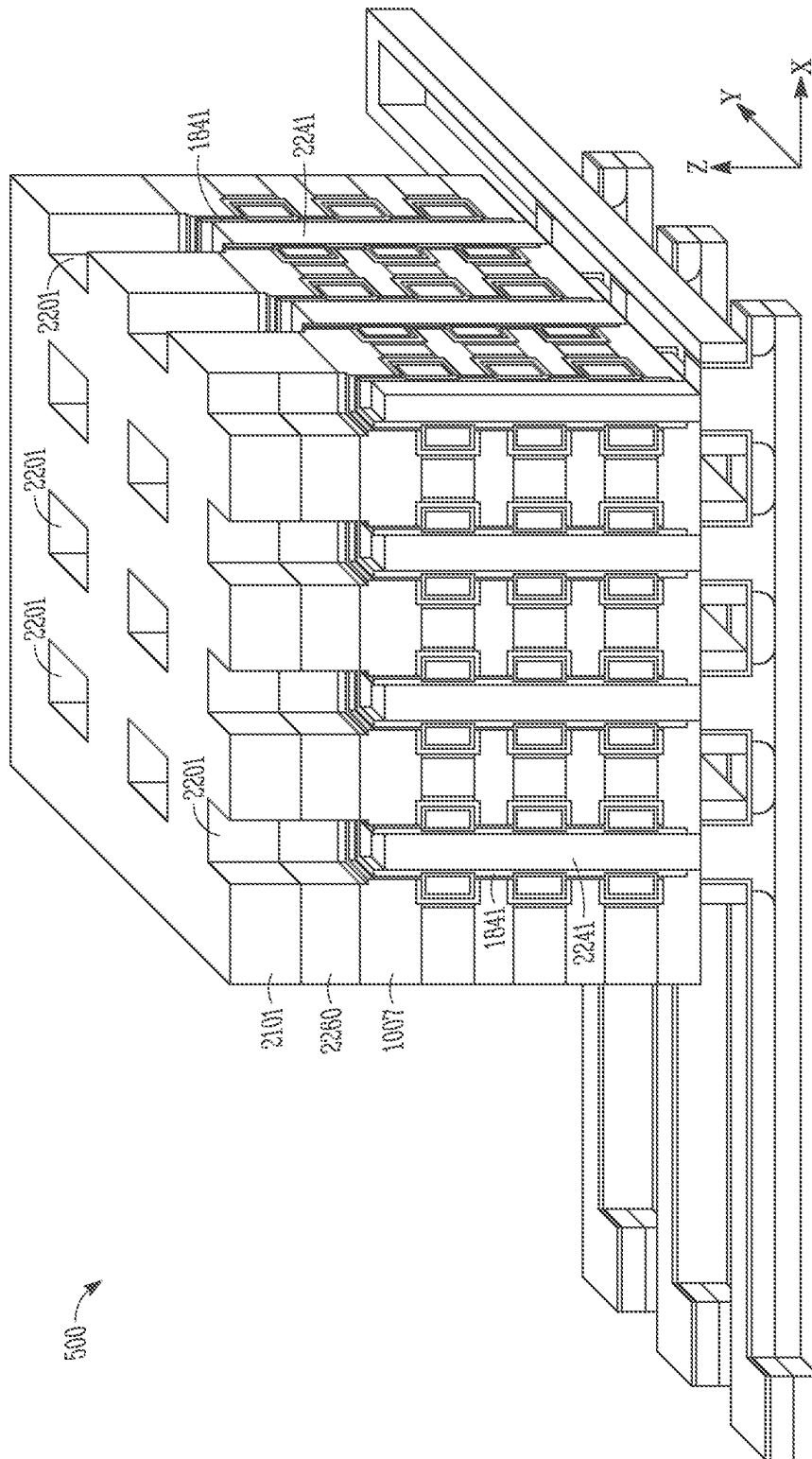

FIG. 22

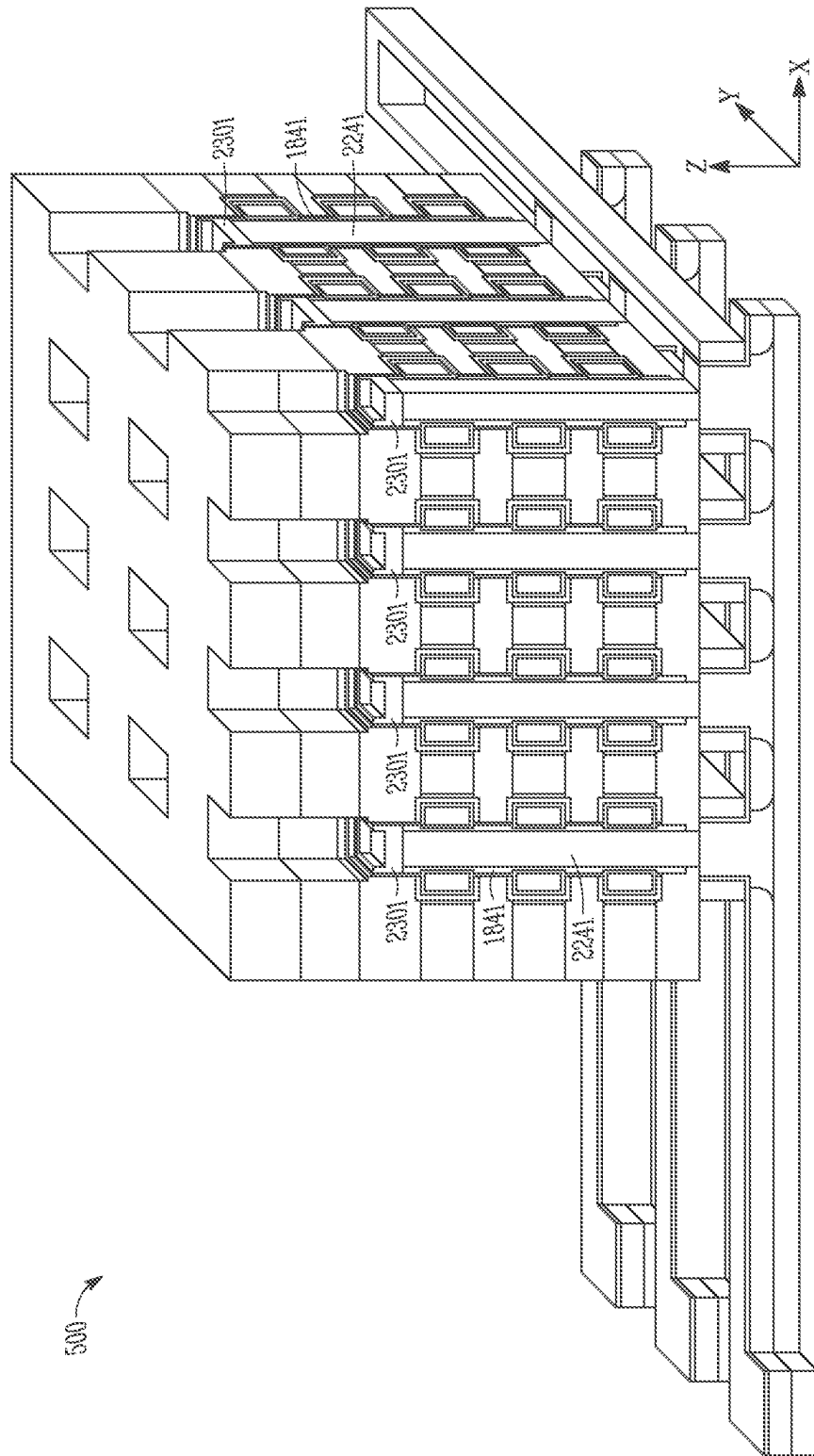

FIG. 23

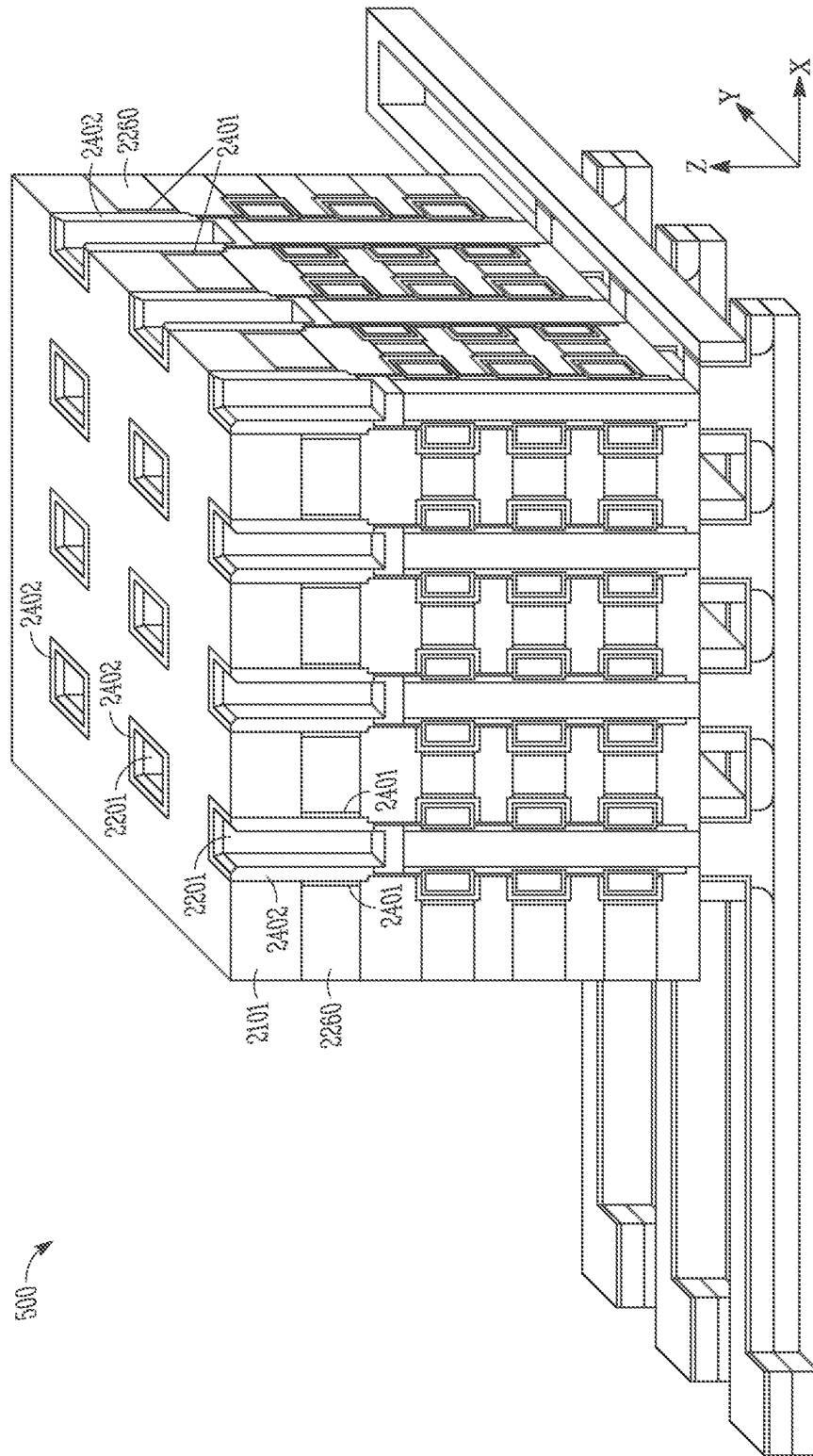

FIG. 24

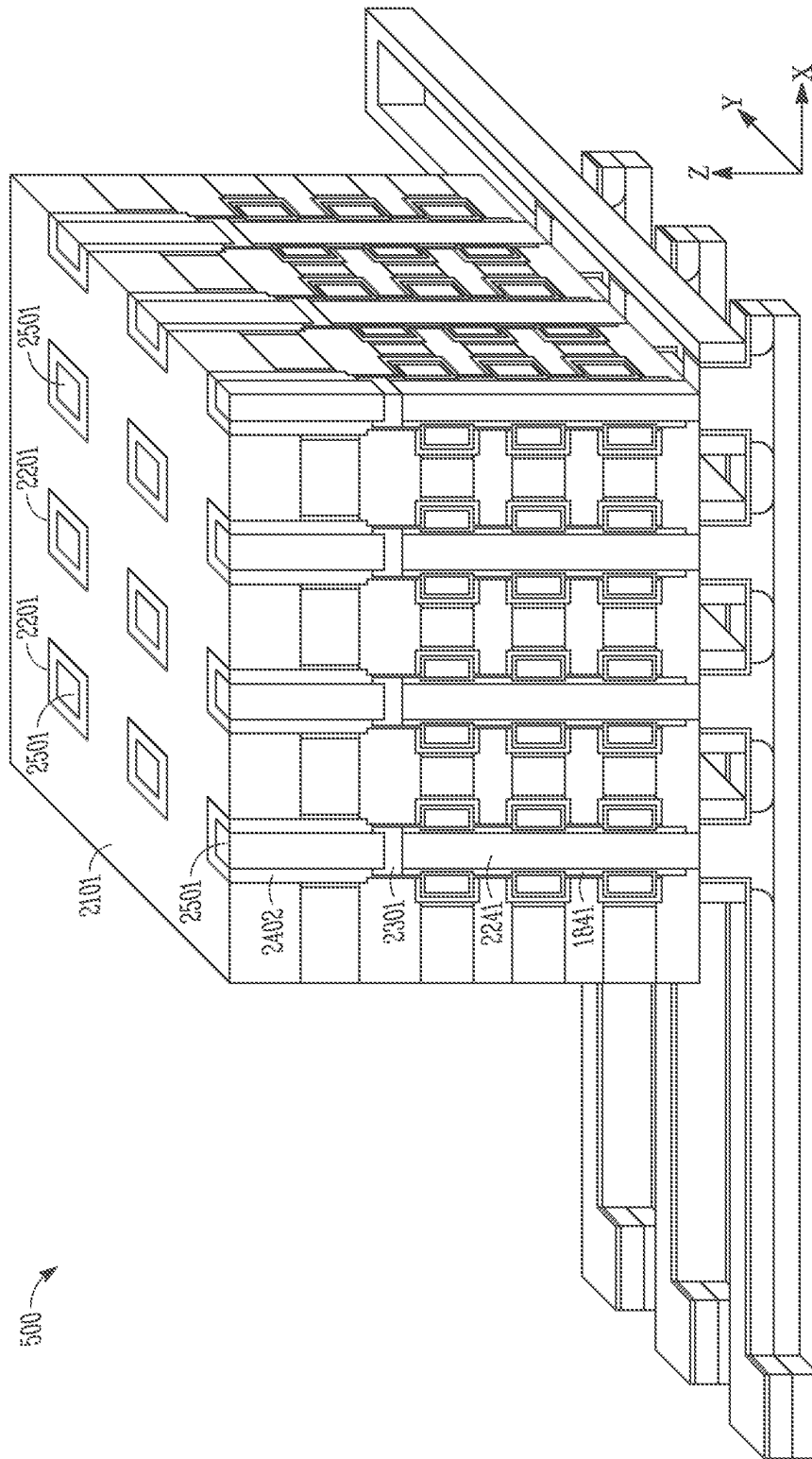

FIG. 25

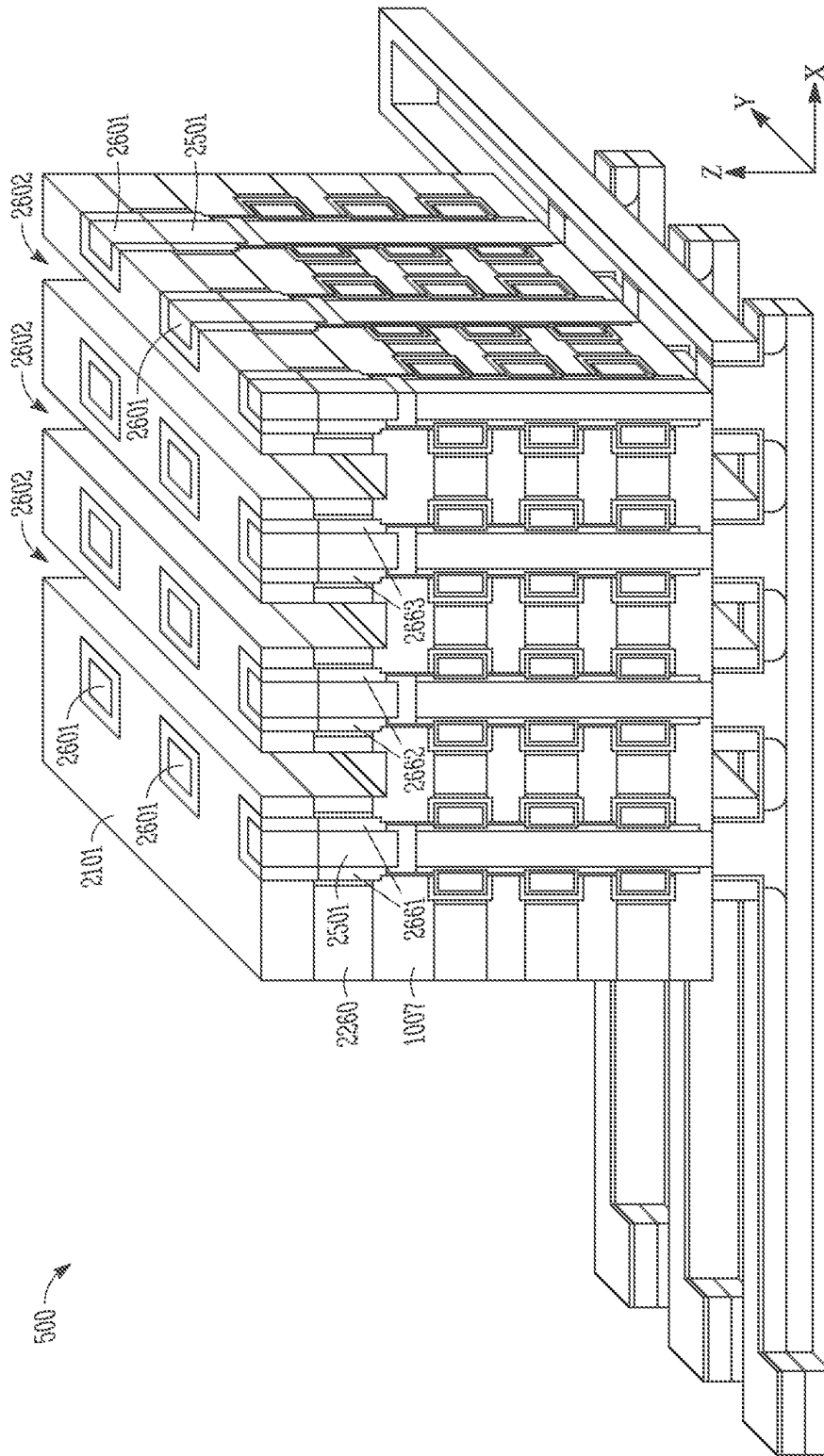

FIG. 26

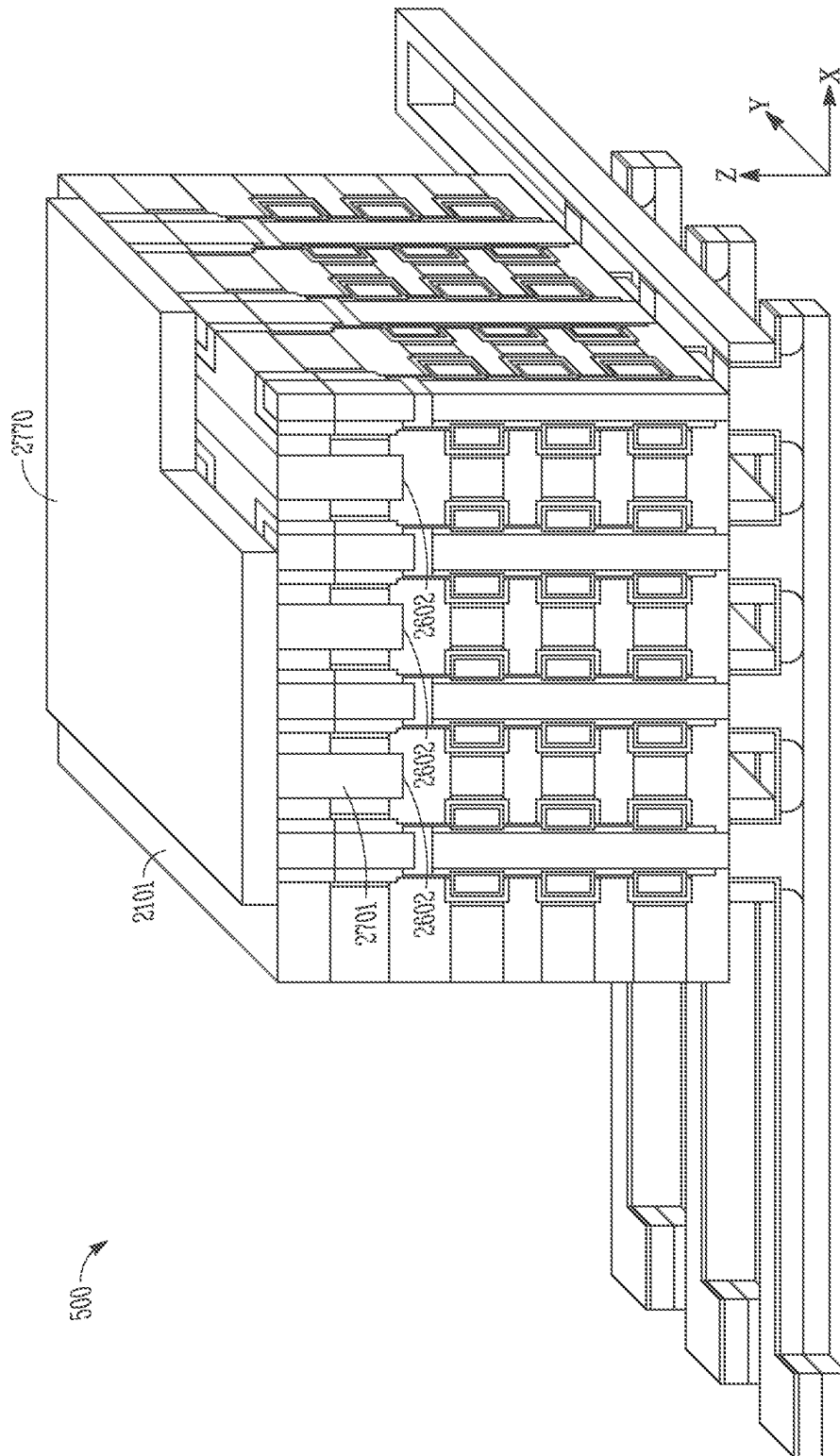

FIG. 27

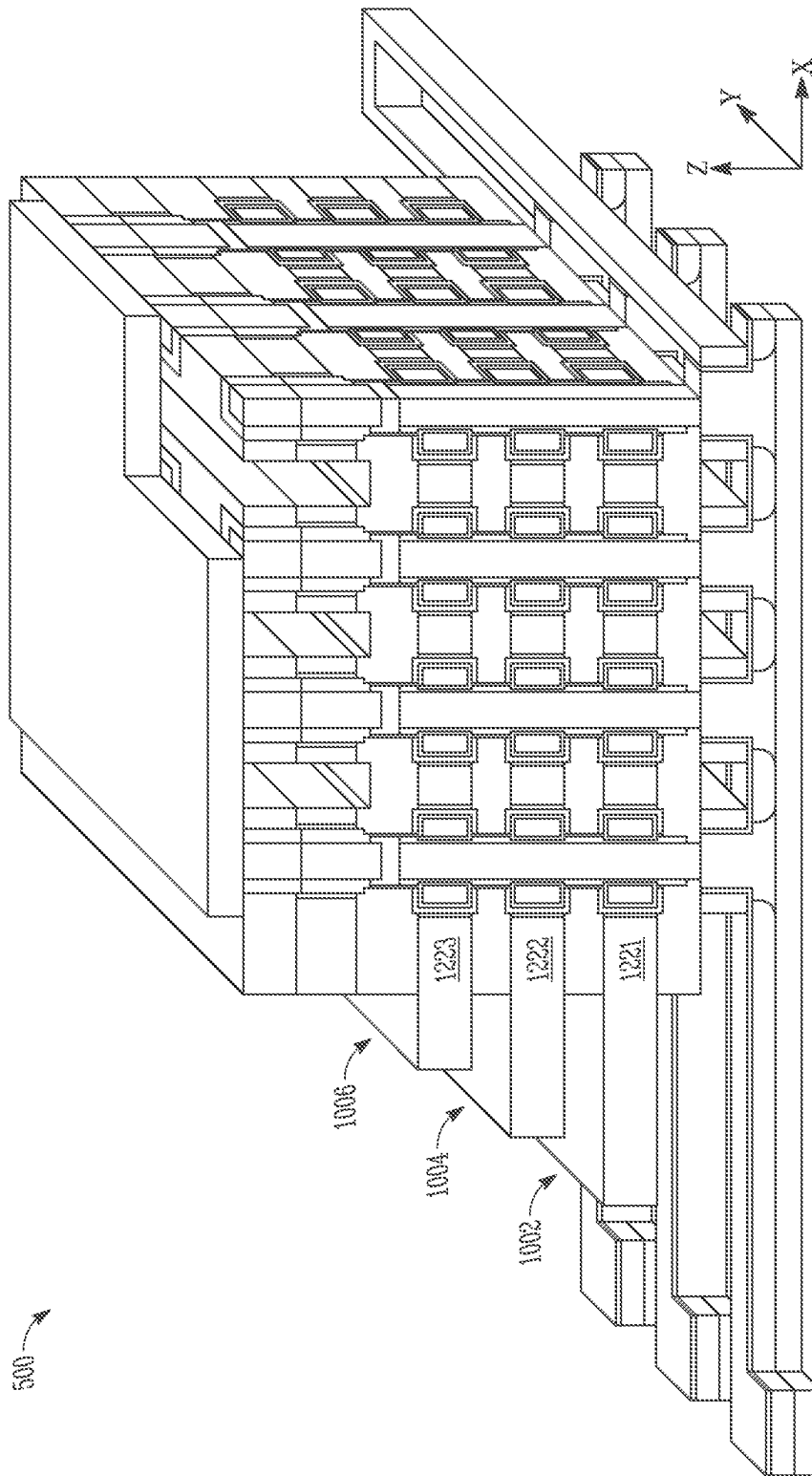

FIG. 28

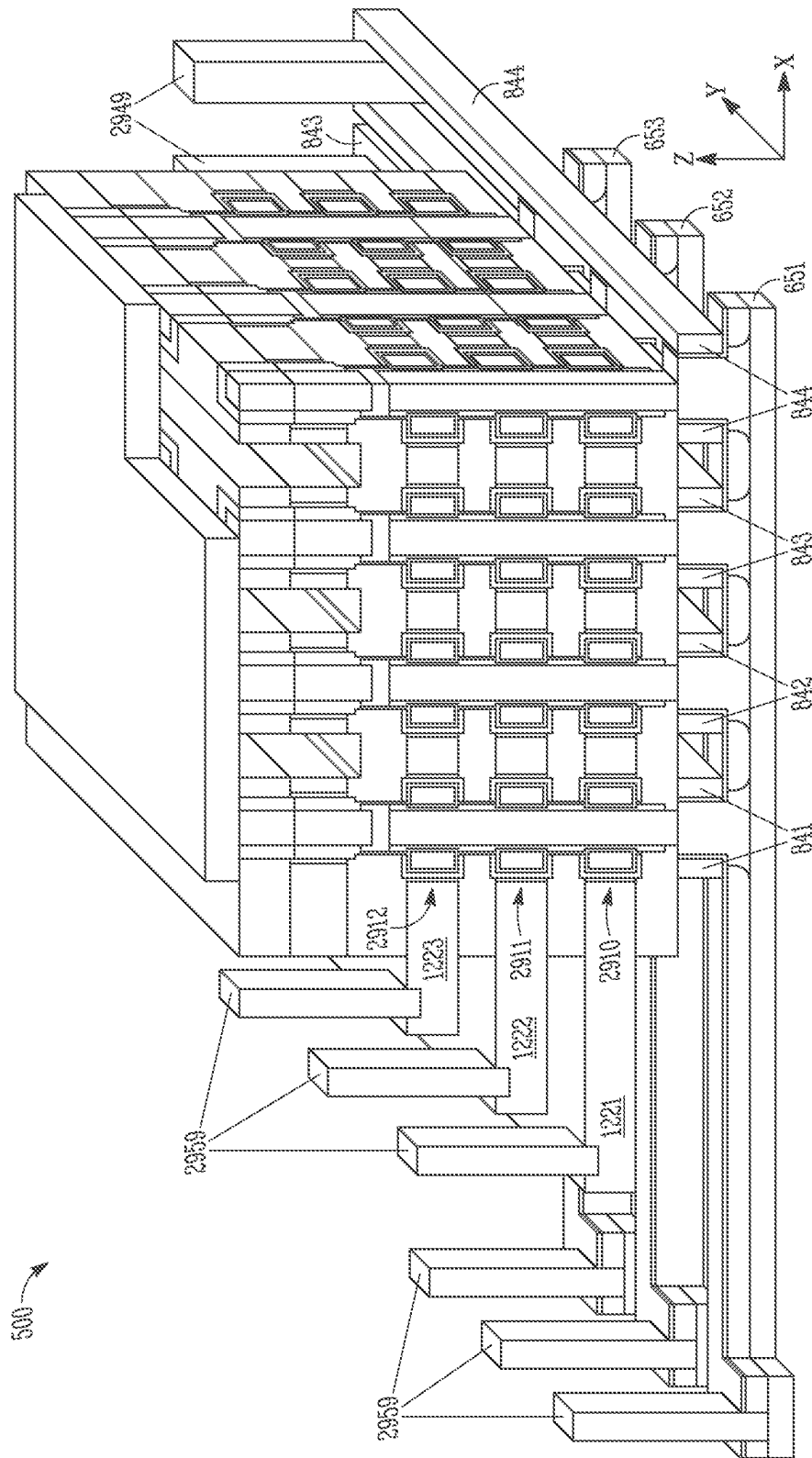

FIG. 29

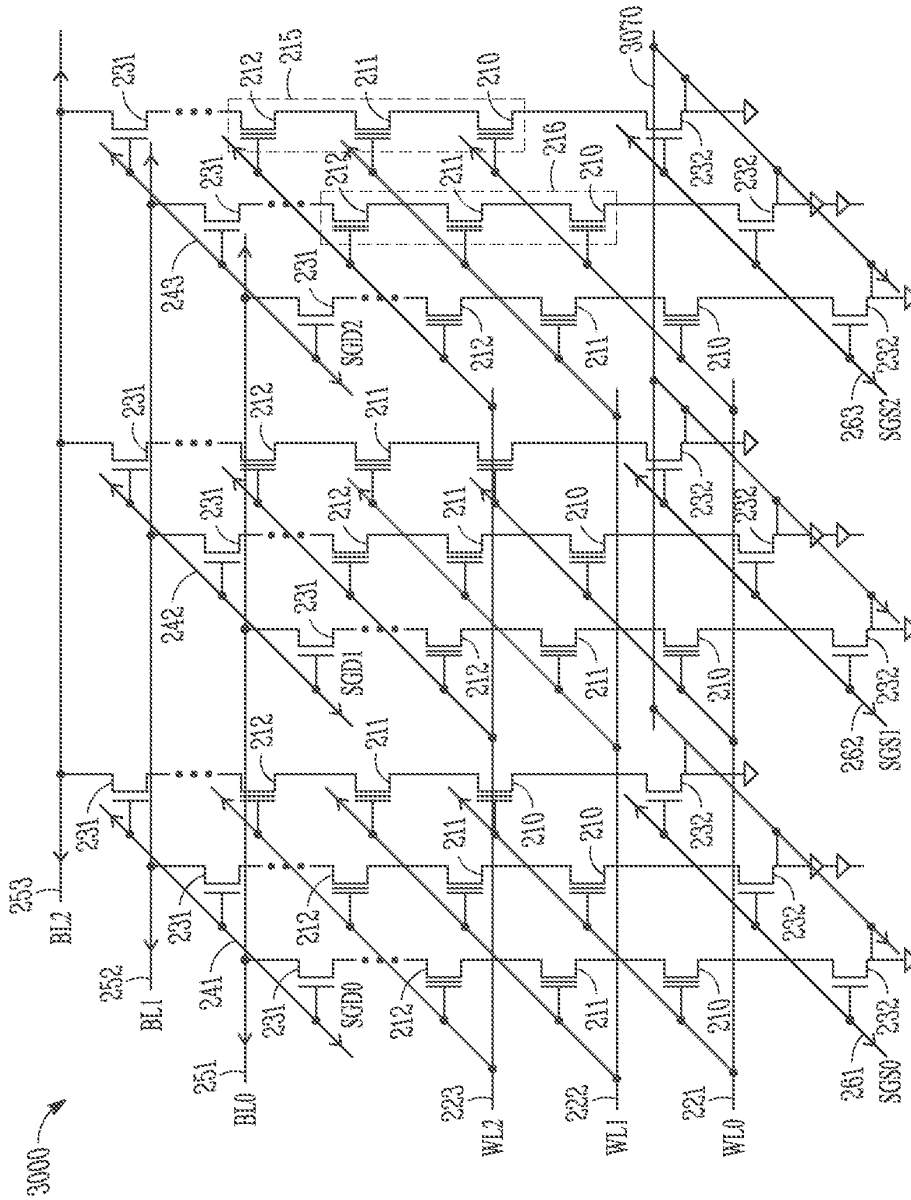

FIG. 30

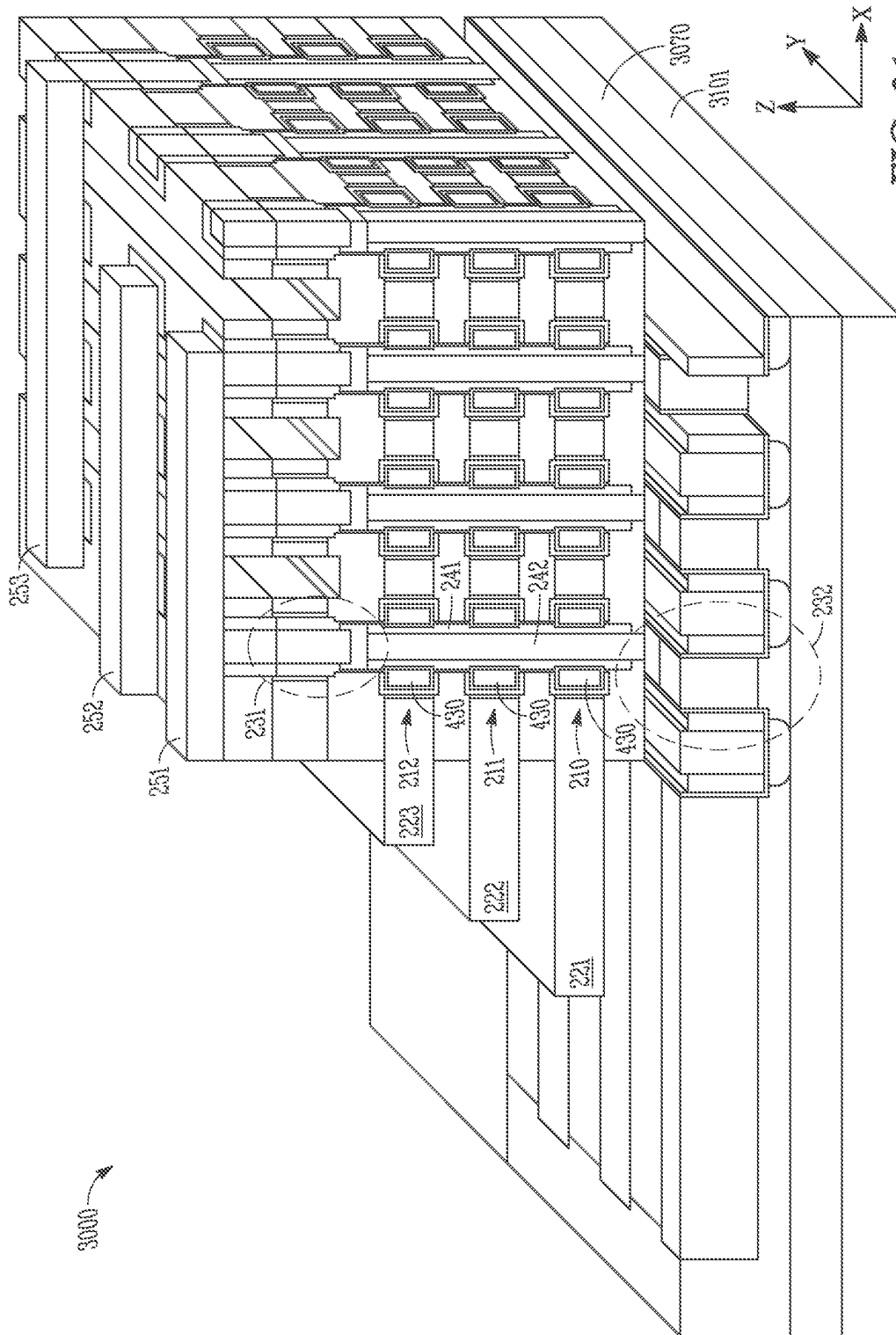

FIG. 31

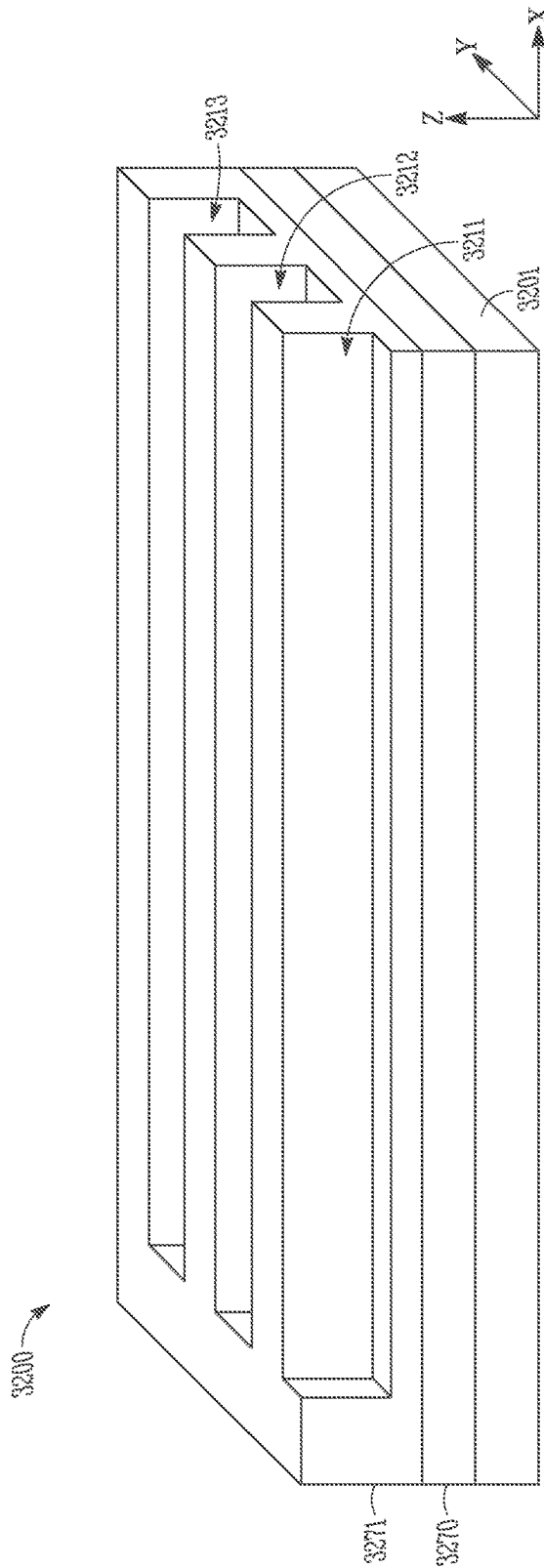

FIG. 32

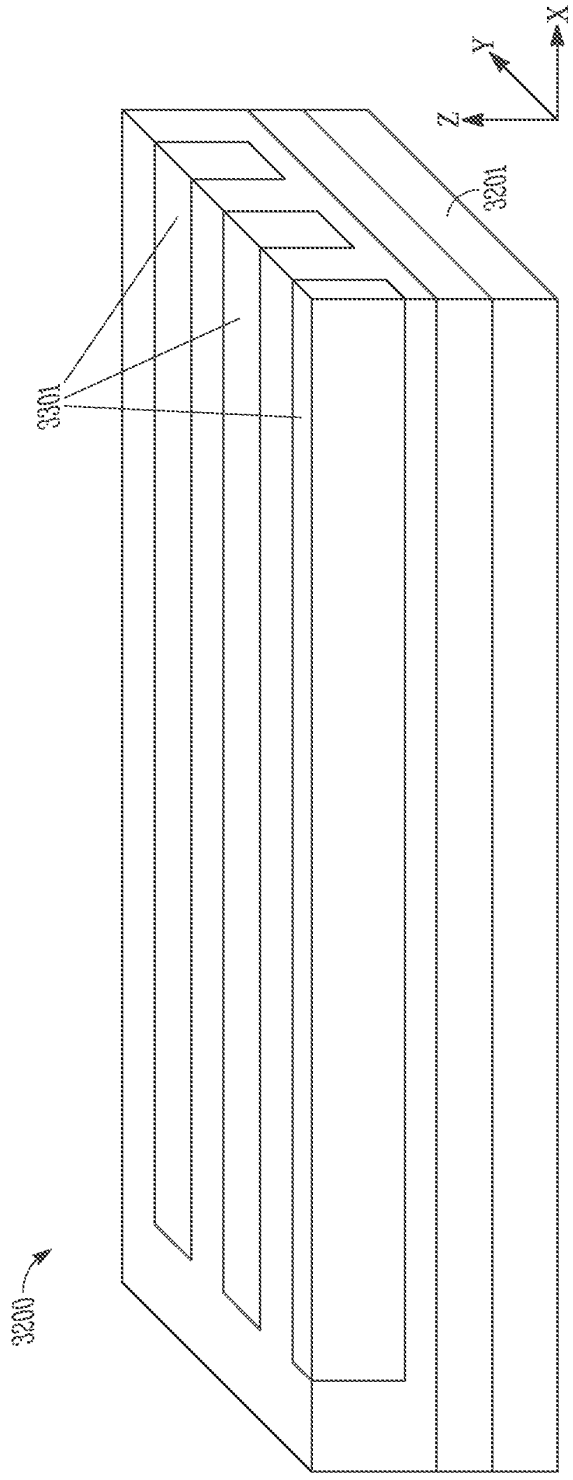

FIG. 33

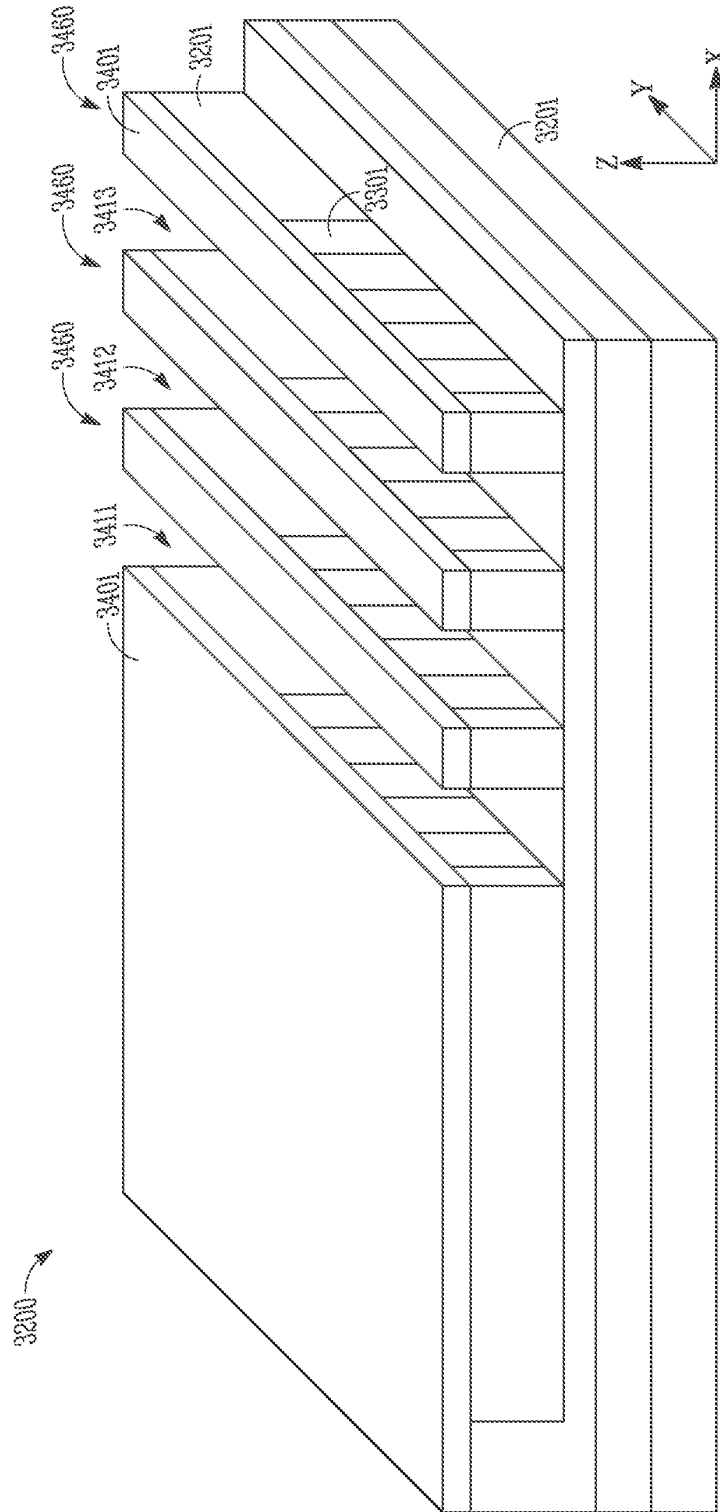

FIG. 34

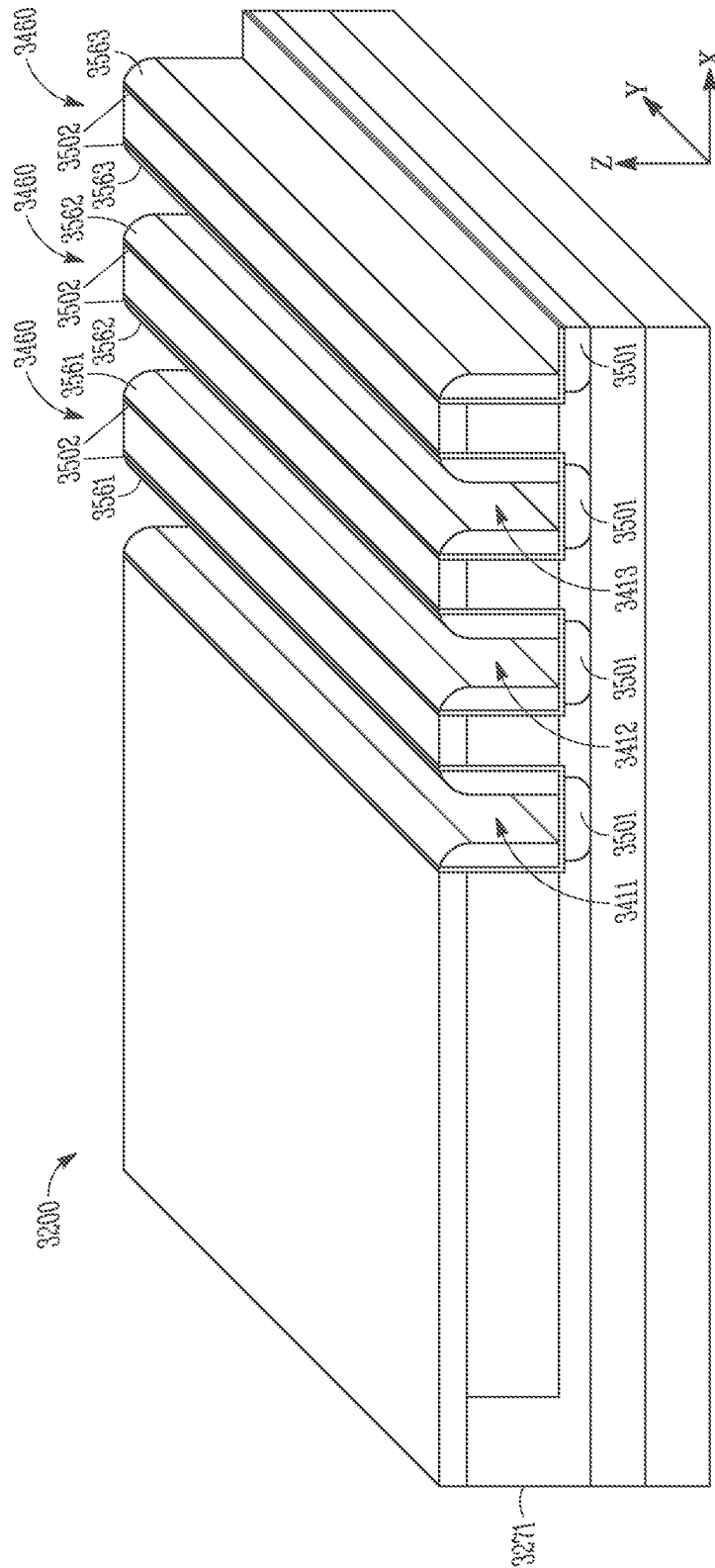

FIG. 35

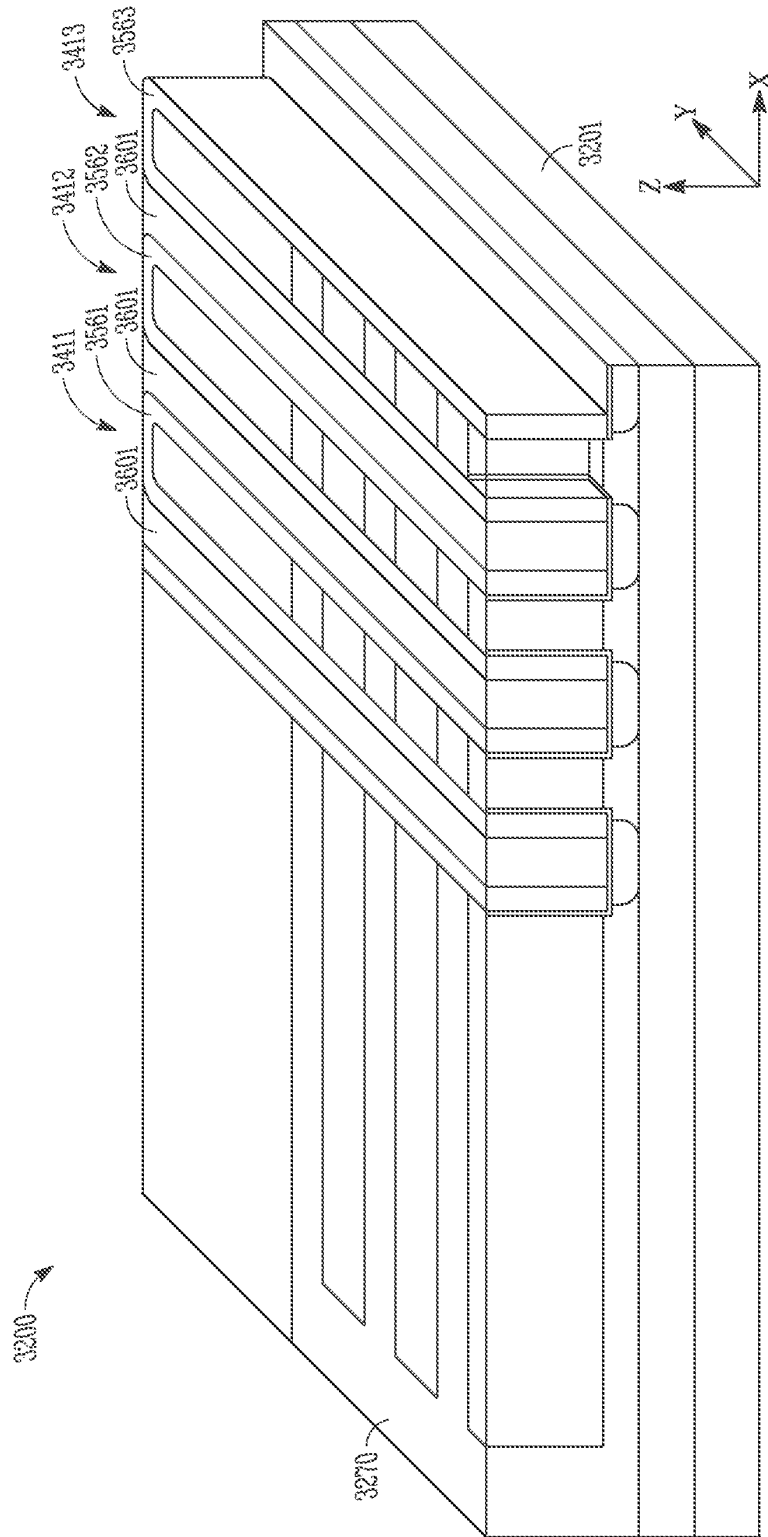

FIG. 36

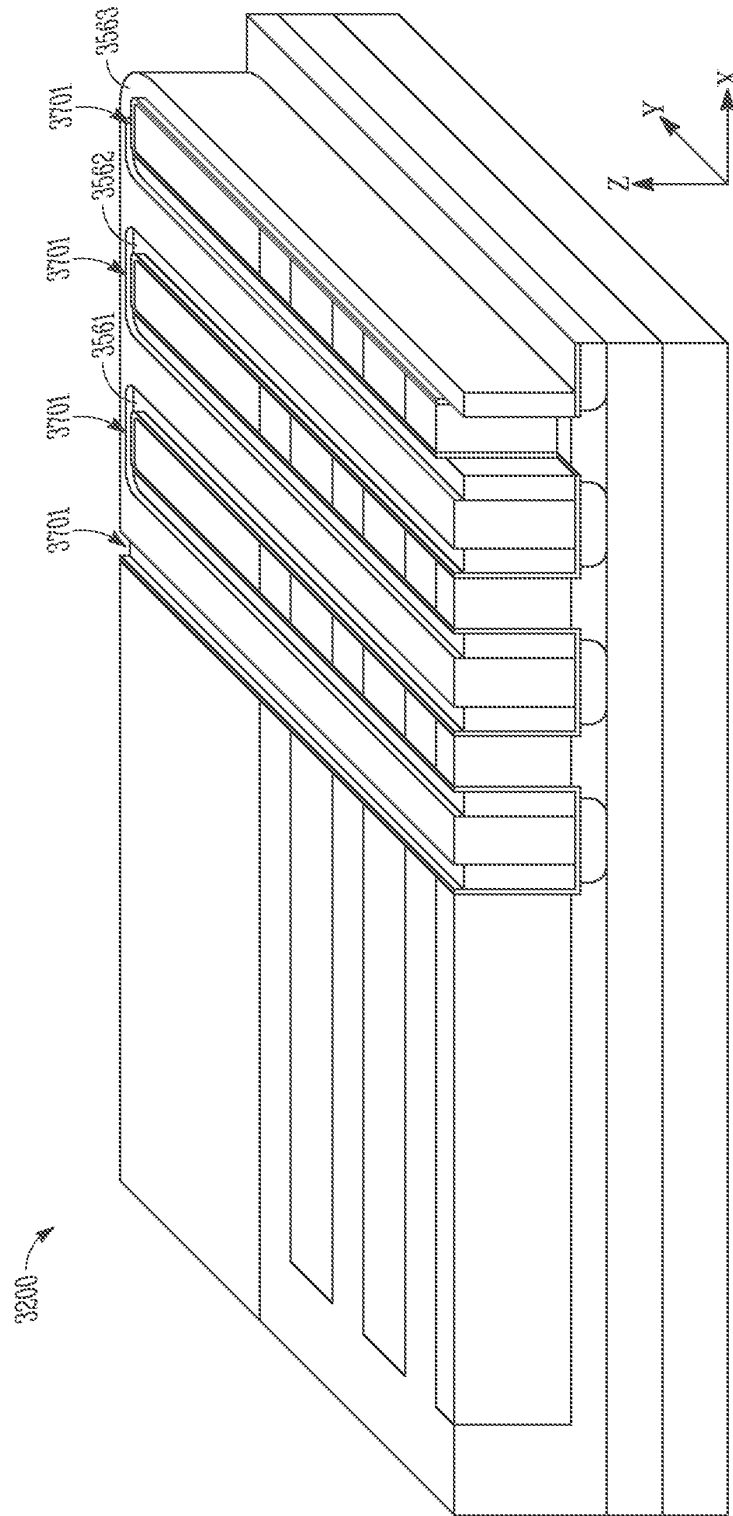

FIG. 37

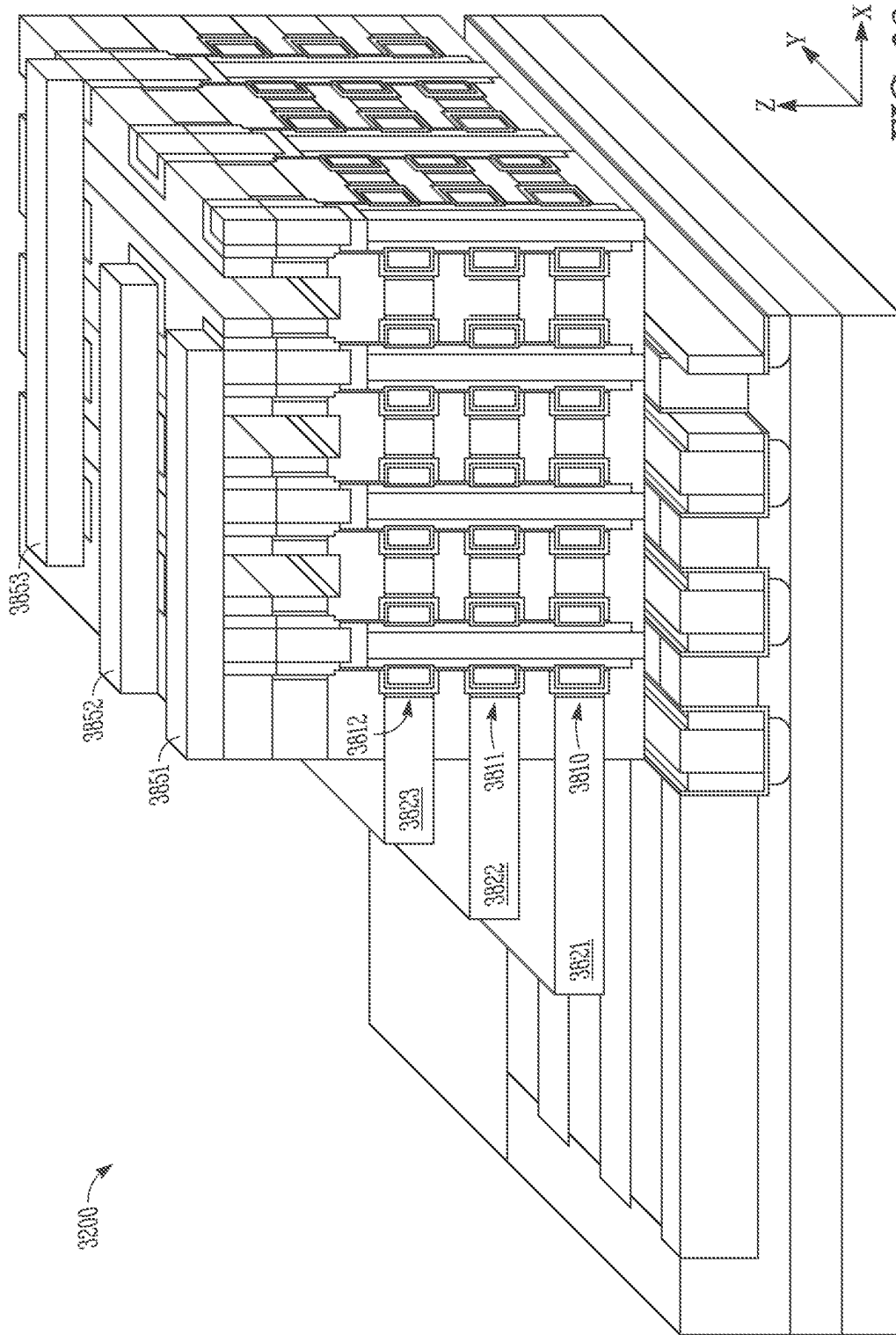

FIG. 38

### THREE DIMENSIONAL MEMORY AND METHODS OF FORMING THE SAME

#### PRIORITY APPLICATION

This application is a continuation of U.S. application Ser. No. 16/125,242, filed Sep. 7, 2018, which is a continuation of U.S. application Ser. No. 15/722,580, filed Oct. 2, 2017, now issued as U.S. Pat. No. 10,090,324, which is a continuation of U.S. application Ser. No. 15/188,273, filed Jun. 21, 2016, now issued as U.S. Pat. No. 9,780,115, which is a continuation of U.S. application Ser. No. 14/041,928, filed Sep. 30, 2013, now issued as U.S. Pat. No. 9,379,005, which is a divisional of U.S. application Ser. No. 12/825,211, filed Jun. 28, 2010, now issued as U.S. Pat. No. 8,803,214, all of which are incorporated herein by reference in their entireties.

#### BACKGROUND

Non-volatile memory devices such as flash memory devices are used in many computers and electronic devices to store information. A flash memory device usually has a write operation to store information (e.g., data and instruction codes), a read operation to retrieve the stored information, and an erase operation to clear information from the memory. As demand for higher density memory device increases, three-dimensional (3D) memory devices have been proposed. An example of a conventional 3D memory device is described by Jiyoung Kim et al. in an article titled “Novel 3-D Structure for Ultra High Density Flash Memory with Vertical-Array-Transistor (VRAT) and Planarized Integration on the same Plane (PIPE)”, published in the 2008 Symposium on VLSI Technology Digest of Technical Papers, pages 22-23. Since 3D memory devices are relatively new, manufacturing these devices can pose fabrication process challenges.

#### BRIEF DESCRIPTION OF THE DRAWINGS

FIG. 1 shows a block diagram of a memory device having a memory array with memory cells, according to an embodiment of the invention.

FIG. 2 shows a schematic diagram of a portion of a memory device having data lines located below memory cells, according to an embodiment of the invention.

FIG. 3 shows a three-dimensional view of a portion of the memory device of FIG. 2, according to an embodiment of the invention.

FIG. 4 shows a portion of a control gate and a memory cell of the memory device of FIG. 3, according to an embodiment of the invention.

FIG. 5 through FIG. 29 show various processes of forming a memory device having data lines located below memory cells, according to an embodiment of the invention.

FIG. 30 shows a schematic diagram of a portion of a memory device having data lines located above memory cells, according to an embodiment of the invention.

FIG. 31 shows a three-dimensional view of a portion of the memory device of FIG. 30, according to an embodiment of the invention.

FIG. 32 through FIG. 38 show various processes of forming a memory device with data lines located above memory cells, according to an embodiment of the invention.

#### DETAILED DESCRIPTION

FIG. 1 shows a block diagram of a memory device 100 having a memory array 102 with memory cells 110 accord-

ing to an embodiment of the invention. Memory cells 110 can be arranged in rows and columns along with access lines 123 (e.g., wordlines having signals WL0 through WLM) and lines 124 (e.g., bit lines having signals BL0 through BLN).

Memory device 100 uses lines 124 and 128 to transfer information within memory cells 110. Memory cells 110 can be physically located in multiple device levels such that one group of memory cells 110 can be stacked on one or more groups of other memory cells 110. Row decoder 132 and column decoder 134 decode address signals A0 through AX on lines 125 (e.g., address lines) to determine which memory cells 110 are to be accessed. Row and column level decoders 136 and 138 of row and column decoders 132 and 134, respectively, determine which of the multiple device levels of memory device 100 that the memory cells 110 to be accessed are located.

A sense amplifier circuit 140 operates to determine the value of information read from memory cells 110 and provide the information in the form of signals to lines 124 and 128. Sense amplifier circuit 140 can also use the signals on lines 124 and 128 to determine the value of information to be written to memory cells 110. Memory device 100 can include circuitry 150 to transfer information between memory array 102 and lines (e.g., data lines) 126. Signals DQ0 through DQN on lines 126 can represent information read from or written into memory cells 110. Lines 126 can include nodes within memory device 100 or nodes (e.g., pins or solder balls) on a package where memory device 100 resides. Other devices external to memory device 100 (e.g., a memory controller or a processor) may communicate with memory device 100 through lines 125, 126, and 127.

Memory device 100 performs memory operations such as a read operation to read information from memory cells 110 and a write operation (sometime referred to as a programming operation) to store information into memory cells 110. A memory control unit 118 controls the memory operations based on control signals on lines 127. Examples of the control signals on lines 127 include one or more clock signals and other signals to indicate which operation, (e.g., a write or read operation) that memory device 100 performs. Other devices external to memory device 100 (e.g., a processor or a memory controller) may control the values of the control signals on lines 127. Specific values of a combination of the signals on these lines can produce a command (e.g., a write or read command) that causes memory device 100 to perform a corresponding memory operation (e.g., a write or read operation).

Each of memory cells 110 can store information representing a value of a single bit or a value of multiple bits such as two, three, four, or other numbers of bits. For example, each of memory cells 110 can store information representing a binary value “0” or “1” of a single bit. In another example, each of memory cells 110 can store information representing a value of multiple bits, such as one of four possible values “00”, “01”, “10”, and “11” of two bits, one of eight possible values “000”, “001”, “010”, “011”, “100”, “101”, “110” and “111”, or one of other values of other number of multiple bits.

Memory device 100 can receive a supply voltage, including supply voltage signals Vcc and Vss, on lines 141 and 142, respectively. Supply voltage signal Vss may operate at a ground potential (e.g., having a value of approximately zero volts). Supply voltage signal Vcc may include an external voltage supplied to memory device 100 from an external power source such as a battery or an alternating-current to direct-current (AC-DC) converter circuitry.

Circuitry 150 of memory device 100 can include a select circuit 152 and an input/output (I/O) circuit 116. Select

circuit 152 responds to signals SEL0 through SELn to select the signals on lines 124 and 128 that can represent the information read from or written into memory cells 110. Column decoder 134 selectively activates the SEL0 through SELn signals based on address signals A0 through AX. Select circuit 152 selects the signals on lines 124 and 128 to provide communication between memory array 102 and I/O circuit 116 during read and write operations.

Memory device 100 can be a non-volatile memory device and memory cells 110 can be non-volatile memory cells such that memory cells 110 can retain information stored thereon when power (e.g., Vcc or Vss, or both) is disconnected from memory device 100. For example, memory device 100 can be a flash memory device such as a NAND flash or a NOR flash memory device, or other kinds of memory devices, such as a variable resistance memory device (e.g., phase change random-access-memory (PCRAM), resistive RAM (RRAM), etc.).

One skilled in the art may recognize that memory device 100 may include other features that are not shown in FIG. 1, to help focus on the embodiments described herein.

Memory device 100 may include at least one of the memory devices and memory cells described below with reference to FIG. 2 through FIG. 38.

FIG. 2 shows a schematic diagram of a portion of a memory device 200 having data lines 251, 252, and 253 located below memory cells 210, 211, and 212, according to an embodiment of the invention. Memory cells 210, 211, and 212 can be grouped into groups, such as a group of memory cells 210, a group of memory cells 211, and a group of memory cells 212. As shown in FIG. 2, the memory cells in each group share the same control gate, such as control gate 221, 222, or 223 (with associated signals WL0, WL1, and WL2). The memory cells are coupled in series as strings, such as strings 215 and 216. Each string can include one of the memory cells from different groups and is coupled between one of transistors 231 and one of transistors 232.

As shown in FIG. 2, transistors 231 have gates coupled to select lines 241, 242, and 243 (with associated signals SGD0, SGD1, and SGD2). Transistors 231 have nodes (e.g., sources) coupled to data lines 251, 252, and 253 (with associated signals BL0, BL1, and BL2). Data lines 251, 252, and 253 sometimes correspond to bit lines or sense lines of a non-volatile memory device.

Transistors 232 have gates coupled to select lines 261, 262, and 263 (with associated signals SGS0, SGS1, and SGS2). Transistors 232 have nodes (e.g., drains) coupled to a common source 270 of memory cell strings in a non-volatile memory device.

FIG. 2 shows three groups of memory cells with associated components coupled to them, as an example. The number of groups of memory cells and their associated components (e.g., control gates and data lines) can vary.

Memory device 200 uses control gates 221, 221, and 223 to control access to memory cells 210, 211, and 212 during a read operation to sense (e.g., read) information stored in memory cells 210, 211, and 212, and during a write operation to store information into memory cells 210, 211, and 212. Memory device 200 uses data lines 251, 252, and 253 to transfer the information read from these memory cells during a read operation.

Transistors 231 and 232 are responsive to signals SGD0, SGD1, and SGD2, and signals SGS0, GS1, and SGS2, respectively, to selectively couple the memory cells to data lines 251, 252, and 253 and common source 270 during a read or write operation.

To help focus on the description herein, the description herein omits detailed description of operations of memory device, such as write, read, and erase operation. One skill in the art would recognize these operations. For example, in an erase operation of memory device 200, a voltage of approximately 20 volts can be applied to data lines 251, 252, and 253 while control gates 221, 221, and 223, select lines 241, 242, and 243, and select lines 261, 262, and 263 can be “floated” (e.g., leave unconnected to a voltage). In this erase operation, electrons from memory elements of memory cells 210, 211, and 212 may move to data lines 251, 253, and 253.

FIG. 3 shows a 3D view of a portion of memory device 200, according to an embodiment of the invention. FIG. 3 also shows X, Y, and Z directions, and device levels 301, 302, and 303 arranged in the Z-direction. Memory cells 210 of the same group can be arranged in rows and columns in the X-direction and Y-direction. Each group of memory cells is located in different device levels 301, 302, or 303. For example, the group having memory cells 210 is located in device level 301. The group having memory cells 211 is located in device level 302. The group having memory cells 212 is located in device level 303.

As shown in FIG. 3, memory cells 210, 211, and 212 in each string (e.g., memory cells between transistors 231 and 232) are substantially vertically aligned in the Z-direction with respect to a substrate underneath data lines 251, 252, and 253. The substrate is not shown in FIG. 3, but can be similar to substrate 503 of FIG. 5 and FIG. 6. FIG. 3 also shows a channel 241 and a conductive material portion 242 extending vertically in the Z-direction and through memory element 430 of memory cells 210, 211, and 212 in the same string between transistors 231 and 232, which corresponds to transistors 231 and 232 of FIG. 2. As shown in FIG. 3, transistor 231 can include a double-gate coupled to a body 391 (e.g., transistor channel) to control (turn on or off) the transistor. The structure of the double-gate can include two segments of the same select line 241 (as shown in FIG. 3), such that the two segments are located on only two respective sides of body 391.

Memory device 200 in FIG. 3 also can include contacts 329, 349, and 359. Contacts 329 provide electrical connections to control gates 221, 222, and 223. Contacts 349 provide electrical connections to select lines 241, 242, 243, and 244. Contacts 359 provide electrical connections to and from data lines 251, 252, and 253. Select line 244 and the memory cell associated with it in the Z-direction are not shown in FIG. 2.

FIG. 4 shows a portion of control gate 221 and a memory cell 210 of memory device 200 of FIG. 3. Control gates 222 and 223 and memory cells 211 and 212 of FIG. 2 have structures similar to control gate 221 and memory cell 210, respectively. As shown in FIG. 4, control gate 221 can include a homogenous material with cavities 420, each cavity being filed with various components, including materials different from the homogenous material. The various components include: a memory element 430; a channel 441, a conductive material portion 442, and dielectrics 421 and 427. Dielectric 421 can include multiple materials 422, 423, and 424 arranged as different layers. As shown in FIG. 4, memory element 430 of each memory cell 210 has a ring shape (e.g., donut shape) with an inner side 451 and an outer side 452. Each of the other memory cells 211 and 212 shown in FIG. 3 also has a ring shape. As shown in FIG. 3, within memory cells 210, 211, and 212 in the same string (e.g., between transistors 231 and 232), the entire ring-shape memory element 430 of each memory cell is substantially

5

vertically aligned (in the Z-direction) with the entire ring-shape memory element of each of the other memory cells in the same string.

Each memory element **430** can store information, such as based on the amount of charge (e.g., number of electrons) therein. In each such memory element **430**, the amount of charge corresponds to the value of information store that memory element. The amount of charge can be controlled in a write operation or in erase operation. For example, electrons from channel **441** or conductive material portion **442**, or both, can move to memory element **430** during a write operation due to a tunneling effect known to those skilled in the art. In an erase operation, electrons from memory element **430** can move back to channel **441** or conductive material portion **442**, or both, to data lines **251**, **253**, and **253** (FIG. 2 and FIG. 3). Alternative embodiments might use a memory element **430** that can store information, such as based on the resistance of the element **430**, for example.

Memory device **200** of FIG. 3 can be formed using processes similar to or identical to those described below with reference to FIG. 5 through FIG. 29.

FIG. 5 through FIG. 29 show various processes of forming a memory device **500** having data lines located below memory cells, according to an embodiment of the invention. Memory device **500** (shown in more details in FIG. 29) can correspond to memory device **300** of FIG. 3.

FIG. 5 shows memory device **500** having a substrate **503**, which can include materials **501** and **502** arranged as layers. Material **501** can include bulk silicon or could be another semiconductor material. Material **502** can be a dielectric material, for example, silicon oxide. FIG. 5 also shows materials **504** and **505** formed over substrate **503**. Forming materials **504** and **505** can include depositing a conductive material over substrate **503** and then depositing another conductive material over material **504**. Material **504** can include a metal or other conductive materials. Material **505** can include undoped polysilicon or doped polysilicon, such as p-type silicon or another conductive materials.

FIG. 5 also shows an X-direction, a Y-direction perpendicular to the X-direction, and a Z-direction perpendicular to both the X-direction and the Y-direction. As shown in FIG. 5, materials **504** and **505** can be formed as different layers, one layer over (e.g., on) one or more other layers in the Z-direction.

As used herein, the term “on” used with respect to two or more materials, one “on” the other, means at least some contact between the materials, while “over” or “overlying” could refer to either a material being “on” another material or where there is one or more additional intervening materials between the materials (e.g., contact is not necessarily required). The term “on”, “over”, or “overlying” does not imply any directionality as used herein unless otherwise explicitly stated as such.

FIG. 6 shows memory device **500** after data lines **651**, **652**, and **653** and device structures **605** have been formed. A process such as etching (e.g., dry etching) can be used to remove portions of materials **504** and **505** (FIG. 5) to form trenches **511** and **512**, which have trench bottoms at material **502**. Each of data lines **651**, **652**, and **653** and each of device structures **605** has a greater dimension (e.g., length) extending in the X-direction. A mask (not shown in FIG. 6) having separate openings extending in the X-direction can be used to form trenches **511** and **512**. As shown in FIG. 6, trenches **511** and **512** divide material **504** (FIG. 5) into separate data lines **651**, **652**, and **653**, which can correspond to data lines **251**, **252**, and **253** of FIG. 2.

6

FIG. 7 shows memory device **500** after pillars **705** have been formed in area **701** of memory device **500**. Pillars **705** are not formed in area **702** of memory device **500**. For simplicity, FIG. 7 through FIG. 29 do not show substrate **503** of FIG. 6. In FIG. 7, a process such as etching (e.g., dry etch) can be used to remove portions of device structures **605** to form trenches **711**, **712**, and **713** in the Y-direction, perpendicular to trenches **511** and **512**, such that pillars **705** can be formed as shown in FIG. 7. A mask (not shown in FIG. 7) having separate openings extending in the Y-direction can be used to form trenches **711**, **712**, and **713**. Each pillar **705** can include a height in the Z-direction of approximately 20 to 50 nanometers. As shown in FIG. 7, pillars **705** are arranged in rows and columns (e.g., in a matrix) in the X-direction and Y-direction. For simplicity, FIG. 7 does not show a dielectric material filled in trenches **511** and **512**. However, forming memory device **500** in FIG. 7 also can include forming a dielectric material (e.g., silicon oxide) to fill trenches **511** and **512** up to a top surface **715** of device structure **605**.

FIG. 8 shows memory device **500** after dielectric **831** and select lines **841**, **842**, **843**, and **844** have been formed. Select lines **841**, **842**, **843**, and **844** can correspond to select lines **241**, **242**, **243**, and **244**, respectively, of FIG. 3. In FIG. 8, dielectrics **831** are formed to electrically isolate select lines **841**, **842**, **843**, and **844** from pillars **705**. Dielectrics **831** can be formed by, for example, depositing a dielectric material (e.g., silicon oxide) on at least two sides of each pillar **705** or by oxidizing pillars **705**. After dielectrics **831** are formed, select lines **841**, **842**, **843**, and **844** can be formed by, for example, depositing a conductive material over pillars **705** and trenches **711**, **712**, and **713** (FIG. 7) and then removing (e.g., etching) a portion of the conductive material to form select lines **841**, **842**, **843**, and **844** having the structure shown in FIG. 8. Examples of the conductive materials for select lines **841**, **842**, **843**, and **844** include polysilicon, metal, or other conductive materials, such as TiN and TaN.

FIG. 8 also shows doped regions **833**, which can be formed by inserting (e.g., implanting) n-type impurities into selective portions of device structure **605**. Examples of n-type impurities include elements such as phosphorus (P) or arsenic (As). The remaining portion of device structures **605** that has not been inserted with n-type impurities may maintain its original material, such as p-type silicon, as described above with reference to FIG. 5.

FIG. 9 shows memory device **500** with select lines **941**, **942**, **943**, and **944**, which are alternative structures for select lines **841**, **842**, **843**, and **844** of FIG. 8. In FIG. 8, opposite sides of each pillar **705** are associated with two different segments of the same select line **841**, **842**, **843**, or **844**. In FIG. 9, except for the top surfaces of pillars **705**, each pillar **705** can be completely surrounded by the material of one of the select line **941**, **942**, **943**, or **944** (e.g., four sides of each pillar **705** are associated with four different segments of the same select line). Higher efficient memory device may be achieved with select lines **941**, **942**, **943**, and **944** in comparison to select lines **841**, **842**, **843**, and **844**. Select lines **941**, **942**, **943**, and **944** can also be alternative structures for select lines **241**, **242**, **243**, and **244**, respectively, of FIG. 3. Thus, each transistor **231** of FIG. 2 and FIG. 3 can include a surrounded gate with a structure shown in FIG. 9. Thus, instead of a double-gate shown in FIG. 3, each transistor **231** of FIG. 3 can alternatively include a surrounded gate having four different segments of the same select line (such as select line **941**) surrounding body **391** (FIG. 3).

FIG. 10 shows memory device **500** after materials **1001** through **1007** are formed over pillars **705** and select lines **841**, **842**, **843**, and **844**. Materials **1001** through **1007** can be

formed in both areas 701 and 702 of memory device 500. However, to focus on the description herein, FIG. 10 does not show some portions of materials 1001 through 1007 in area 702. The description below with reference to FIG. 28 and FIG. 29 describes forming additional components (e.g., components similar to contacts 329 of FIG. 3) in area 702 of memory device 500.

In FIG. 10 through FIG. 29, for simplicity, some number designations associated with some components of memory device 500 may not be repeated from one figure to another figure. In FIG. 10, before forming materials 1001 through 1007, a dielectric material (not shown in FIG. 10), such as silicon oxide, can be formed to fill gaps 1041, 1042, and 1043. Forming materials 1001 through 1007 can include alternately depositing dielectric material and conductive material in an interleave fashion, such that these materials are alternately stacked over each other in the Z-direction, as shown in FIG. 10. Materials 1001, 1003, 1005, and 1007 can include dielectric materials, such as silicon oxide. Materials 1002, 1004, and 1006 can include conductive materials, such as metal or polysilicon (e.g., n-type silicon for p-type silicon). As shown in FIG. 10, materials 1001 through 1007 are formed such that materials 1002, 1004, and 1006 are electrically isolated from each other by materials 1001, 1003, 1005, and 1007.

FIG. 11 shows memory device 500 after openings (e.g., holes) 1101 have been formed in material 1002 through 1107. Holes 1101 are formed such that each hole 1101 can be aligned substantially directly over a corresponding pillar 705, as illustrated in FIG. 11. Forming holes 1101 can include removing (e.g., etching) a portion of each of materials 1002 through 1007, stopping at material 1001, such that at least a portion of material 1001 or the entire material 1001 remains to separate holes 1101 from pillars 705. Forming holes 1101 results in forming cavities 1110 in each of materials 1003, 1005, and 1007, and cavities 1120 in each of materials 1002, 1004, and 1006. As shown in FIG. 12, cavities 1110 in the materials 1003, 1005, and 1007 are substantially aligned directly over cavities 1120 in the other materials 1002, 1004, and 1006. Each cavity 1110 and each cavity 1120 may have substantially the same diameter, D1. Diameter D1 can also be considered the diameter of each hole 1101 at the location of each cavity 1110 and each cavity 1120.

FIG. 12 shows memory device 500 after cavities 1220 have been formed in materials 1002, 1004, and 1006 (used to form control gates 1221, 1222, and 1223). Forming cavities 1220 can include enlarging the size of cavities 1120 (FIG. 11) while keeping the size of cavities 1110 substantially unchanged (e.g., remaining substantially at diameter D1). For example, enlarging the size of cavities 1120 (FIG. 11) can include selectively removing (e.g., selective wet or dry etching) a portion of each of materials 1002, 1004, and 1006 at each cavity 1120 (FIG. 11) such that the diameter of each cavity 1220 increases to substantially diameter D2, while the diameter D1 at each cavity 1110 remains substantially unchanged. Diameter D2 is greater than diameter D1. Forming cavities 1120 in materials 1002, 1004, and 1006 also form control gates 1221, 1222, and 1223, which can correspond to control gates control gates 221, 222, and 223 of FIG. 2.

FIG. 13 shows more details of control gate 1221 of FIG. 12. Control gates 1222 and 1223 of FIG. 12 have a similar structure as control gate 1221. As shown in FIG. 13, control gate 1221 can include a homogenous material with cavities

1220 of FIG. 11 being arranged in rows and columns in the X-direction and Y-direction. Each cavity 1220 can include a sidewall 1225.

FIG. 14 and FIG. 15 shows memory device 500 after dielectrics 1421 and memory elements 1430 have been formed in cavities 1220. For simplicity, FIG. 15 does not show dielectrics 1421 and memory elements 1430 in all cavities 1220. Each dielectric 1421 can be formed on sidewall 1225, such that each dielectric 1421 can be located between the material of control gate 1221 and memory element 1430, and such that memory element 1430 can be electrically isolated from the material of control gate 1221 by at least a portion of dielectric 1421. Forming dielectric 1421 can include forming multiple materials 1422, 1423, and 1424 (FIG. 15) at different times, one material after another. Forming material 1422 can include oxidizing a portion (e.g., a surface) of sidewall 1225 to form dielectric material (e.g., silicon oxide) on sidewall 1225. Alternatively, forming material 1422 can include depositing dielectric material (e.g., silicon oxide) on sidewall 1225. Forming material 1423 can include depositing dielectric material (e.g., silicon nitride) on material 1422, wherein a portion of that dielectric material may also form on sidewall 1425 of each cavity 1110. Forming material 1424 can include depositing dielectric material (e.g., silicon oxide) on material 1423.

Memory elements 1430 can be formed after dielectrics 1421 are formed. As shown in FIG. 15, each memory element 1430 has a ring shape (e.g., a donut shape) with an inner side 1451 and an outer side 1452 of FIG. 14. Forming memory elements 1430 can include depositing a material in holes 1101. Since cavities 1220 of FIG. 14 are substantially aligned with cavities 1110, the material (that forms memory element 1430) may fill both cavities 1110 and 1120. Then, a portion (e.g., center portion in each hole) of the material that forms memory elements 1430 can be removed (e.g., by etching in the same, single, etching step) such that the material in cavities 1110 can be removed (e.g., completely removed) and the material in cavities 1220 is not completely removed but partially removed. As shown in FIG. 14, after the material that forms memory elements 1430 is removed from cavities 1110, a portion of dielectric material 1423 (e.g., silicon nitride, that was formed on material 1422) may be exposed. As shown in FIG. 14, after the material that forms memory elements 1430 is partially removed from cavities 1220, memory element 1430 (formed by the remaining material in a cavity 1220) associated with the same hole 1101 may have its inner side 1451 substantially aligned with sidewall 1425 (or sidewall 1425 with portions of materials 1422 and 1423 of cavities 1110) of cavities 1110.

The material of memory elements 1430 can include, for example, semiconductor material (e.g., polysilicon), dielectric charge trapping material, such as silicon nitride or other dielectric charge trapping materials, or a variable resistance material, such as a phase change material (e.g., GST). During removing (e.g., etching) a portion of the material that forms memory elements 1430, portions 1401 of material 1001 located over pillars 705 can also be removed to reduce the thickness of portions 1401.

FIG. 16 and FIG. 17 show memory device 500 after dielectric 1627 has been formed on inner side 1451 of memory element 1430 and in cavities 1110. Forming dielectric 1627 can include depositing dielectric material (e.g., silicon oxide) on inner side 1451. Alternatively, forming dielectric 1627 can include oxidizing a portion (e.g., inner side 1451) of memory element 1430. Forming dielectric 1627 (e.g., by oxidation) may also consume material 1423

(FIG. 14) formed on material 1422, which formed on sidewall 1425 of cavities 1110. Thus, dielectric 1627 may also form in cavities over material 1422.

FIG. 18 and FIG. 19 show memory device 500 after channels 1841 have been formed on dielectrics 1627 in both cavities 1110 and 1220. Forming channels 1841 can include depositing a conductive material on dielectrics 1627. An etching process can be used to reduce the thickness of the conductive material after it is deposited. The conductive material of channels 1841 can include doped polysilicon, which can have the same material type (e.g., p-type) as pillars 705. FIG. 18 also shows a formation of openings 1801, which can be formed by removing (e.g., by etching) portions 1401 (FIG. 14) located over pillars 705. As shown in FIG. 19, channel 1841 is facing memory elements 1430 and is electrically isolated from memory element 1430 by at least a portion of dielectric 1627.

FIG. 20 shows memory device 500 after a conductive material 2001 has been formed by, for example, depositing undoped or lightly doped polysilicon to place channels 1841 in electrical communication with pillars 705. As shown in FIG. 20, conductive material 2001 forms a continuous conductive path between channels 1841 and data lines 651, 652, and 653 through pillars 705.

FIG. 21 shows memory device 500 after dielectric material 2101 (e.g., silicon oxide) has been formed over conductive material 2001.

FIG. 22 shows memory device 500 after a formation of openings (e.g., holes 2201), a conductive material portion 2260, and conductive material portions 2241. Holes 2201 are formed such that each hole 2201 can be aligned substantially directly over channels 1841, as illustrated in FIG. 22. Forming holes 2201 can include removing (e.g., etching) a portion of dielectric material 2101 and a portion of conductive material 2001 (FIG. 21), stopping at a location in material 1007. Holes 2201 can be formed such that after a portion of conductive material 2001 is removed during the formation of holes 2201, conductive material 2001 is separated into conductive material portion 2260 and conductive material portions 2241, as illustrated in FIG. 22.

FIG. 23 shows memory device 500 after doped regions 2301 have been formed. Forming doped regions 2301 can include inserting (e.g., implanting) n-type impurities into top parts of conductive material portions 2241. Doped regions 2301 can provide a relatively low resistance connection between channels 1841 and other components of memory device 500.

FIG. 24 shows memory device 500 after dielectrics 2401 and channels 2402 have been formed. Dielectrics 2401 (e.g., silicon oxide) is formed on sidewalls of conductive material portion 2260 at the location of holes 2201. Channels 2402 are formed on sidewalls of dielectric material 2101 and on dielectrics 2401.

FIG. 25 shows memory device 500 after conductive material 2501 has been formed in each of holes 2201, such that channel 2402 can be electrically coupled to channel 1841 through conductive material 2501, doped region 2301, and conductive material portion 2241. Forming conductive material 2501 in each of holes 2201 can include depositing a conductive material (e.g., polysilicon) over material, such that the conductive material fills holes 2201. Then, a top portion of the conductive material can be removed by, for example, etching back the conductive material or by chemical mechanical planarization (CMP).

FIG. 26 shows memory device 500 after doped regions 2601 and select lines 2661, 2662, and 2663 have been formed. Forming doped regions 2601 can include inserting

(e.g., implanting) n-type impurities into top portions of conductive material 2501. Forming select lines 2661, 2662, and 2663 can include removing parts of dielectric material 2101 and conductive material portion 2260 to form trenches 2602, which have trench bottoms partially extending into material 1007. As shown in FIG. 26, trenches 2602 separate conductive material portion 2260 into select lines 2661, 2662, and 2663, which can correspond to select lines 261, 262, and 263 of FIG. 2.

FIG. 27 shows memory device 500 after material 2701 and a common source 2770 have been formed. Forming material 2701 can include depositing a dielectric material (e.g., silicon dioxide) over material 2101, such that the dielectric material fills trenches 2602. Then, a top portion of the dielectric material can be removed by, for example, etching back the dielectric material or by CMP. Forming common source 2770 can include depositing a conductive material (e.g., metal) over materials 2701 and 2101.

FIG. 28 shows memory device 500 after materials 1001 through 1007 in area 702 (FIG. 10) are processed (e.g., by patterning) to form a stair like pattern with material between the stairs are not shown in FIG. 28. As mentioned above in the description of FIG. 10, some portions of materials 1001 through 1007 are omitted from area 702 of FIG. 10 through FIG. 27 for clarity. FIG. 28 shows material 1001 through 1007 in area 702 after they have been processed to form the stair like pattern. As shown in FIG. 28, control gates 1221, 1222, and 1223 are formed from materials 1002, 1004, and 1006, respectively, which are formed in the stair like pattern.

FIG. 29 shows memory device 500 after contacts 2929, 2949, and 2959 have been formed. Contacts 2929 provide electrical connections to control gates 1221, 1222, and 1223. Contacts 2949 provide electrical connections to select lines 841, 842, 843, and 844. Contacts 2959 provide electrical connections to and from data lines 651, 652, and 653.

As shown in FIG. 29, memory device 500 can include components and memory cells 2910, 2911, and 2912 similar to or identical to components and memory cells 210, 211, and 212 of memory device 300 described above with reference to FIG. 2 and FIG. 3.

One skilled in the art may readily recognize that additional processes may be performed to form additional features of a memory device, such as memory device 500 described above. Thus, to help focus on the embodiments described herein, FIG. 5 through FIG. 29 described above and FIG. 30 through FIG. 38 described below show only some of the features of a memory device, such as memory device 500.

FIG. 30 shows a schematic diagram of a portion of a memory device 300 having data lines 251, 252, and 253 located above memory cells 210, 211, and 212, according to an embodiment of the invention. Memory device 300 can include components similar to those of memory device 200 of FIG. 3. Thus, for simplicity, similar or same components between memory device 200 and memory device 3000 are given the same number designations. The detailed description of these similar components is not repeated in FIG. 30. Main differences between memory device 3000 and memory device 200 include the locations of data lines 251, 252, and 253 and common source 3070 of memory device 3000 to enable global erase operation. As shown in FIG. 30, data lines 251, 252, and 253 are located above memory cells 210, 211, and 212. Common source 3070 is located below memory cells 210, 211, and 212 and can couple directly to at least a portion of a substrate of memory device 3000 (e.g., substrate 3101 in FIG. 31). This main difference may allow voltages to be applied to various components of memory

device 3000 in a different way during an erase operation and memory device 3000 function differently (e.g., during the global erase operation) in comparison with the erase operation (e.g., local erase operation) of memory device 200. For example, in an erase operation of memory device 3000, a voltage of approximately 20 volts can be applied to common source 3070, while control gates 221, 221, and 223, data lines 251, 252, and 253, select lines 241, 242, and 243, and select lines 261, 262, and 26 can be “floated”. In this erase operation, electrons from memory elements of memory cells 210, 211, and 212 may move (e.g., by tunneling) to common source 3070 (e.g., global erase). In memory 200, as described above with reference to FIG. 2, FIG. 3, and FIG. 4, during an erase operation, electrons from memory elements of memory cells 210, 211, and 212 may move to data lines 251, 253, and 253 (e.g., local erase)

FIG. 31 shows a 3D view of a portion of the memory device 3000 of FIG. 30, according to an embodiment of the invention. As shown in FIG. 31, data lines 251, 252, and 253 are located above memory cells 210, 211, and 212, common source 3070 is located below memory cells 210, 211, and 212 and is coupled to a substrate 3101. Substrate 3101 can include semiconductor material, such as p-type silicon.

As shown in FIG. 31, memory cells 210, 211, and 212 in each string (e.g., memory cells between transistors 231 and 232) are substantially vertically aligned in the Z-direction with respect to substrate 3101. Transistor 232 can include a double-gate or surrounded gate similar to the double-gate (FIG. 3) or surrounded gate (FIG. 9) of transistor 231 of FIG. 3. FIG. 31 also shows a channel 441 and a conductive material portion 442 extending vertically in the Z-direction and through memory element 430 of memory cells 210, 211, and 212 in the same string between transistors 231 and 232, which corresponds to transistors 231 and 232 of FIG. 30.

Memory element 430 in each of memory cells 210, 211, and 212 has a ring shape. As shown in FIG. 31, within memory cells 210, 211, and 212 in the same string, the entire ring-shape memory element 430 of each memory cell is substantially vertically aligned (in the Z-direction) with the entire ring-shape memory element of each of the other memory cells in the same string.

FIG. 32 through FIG. 38 show various processes of forming a memory device 3200 having data lines located above memory cells, according to an embodiment of the invention. Memory device 3200 (shown in more details in FIG. 38) can correspond to memory device 3000 of FIG. 31.

FIG. 32 shows memory device 3200 having a substrate 3201 and trenches 3211, 3212, and 3213, and substrate portions 3270 and 3271 formed on a top portion of substrate 3201. Substrate 3201 can include semiconductor material, such as bulk silicon. Top substrate portions 3270 and 3271 can be formed by inserting (e.g., implanting) p-type impurities into a top portion of substrate 3201. Thus, substrate portions 3270 and 3271 can include p-type silicon. Forming trenches 3211, 3212, and 3213 and substrate portion 3270 can include removing (e.g., etching) a portion of substrate portion 3271. During a write or read operation of memory device 3200, substrate portion 3270 can be coupled to a potential, such as to ground. During an erase operation of memory device 3200, substrate portion 3270 can be coupled to a voltage, for example, approximately 20 volts.

FIG. 33 shows memory device 3200 after material 3301 has been formed in trenches 3211, 3212, and 3213 (FIG. 32). Forming material 3301 can include depositing dielectric material (e.g., silicon oxide) over substrate 3201 to fill trenches 3211, 3212, and 3213. Then, a top portion of the dielectric material can be removed by, for example, CMP.

FIG. 34 shows memory device 3200 after material 3401 and trenches 3411, 3412, and 3413, and device structures 3460 have been formed. Forming material 3401 can include depositing dielectric material (e.g., silicon oxide, or silicon nitride) over substrate 3201 and material 3301. Forming trenches 3411, 3412, and 3413 can include removing (e.g., etching) portions of substrate 3201, material 3301, and material 3401. Device structures 3460 are formed as a result of the formation of trenches 3411, 3412, and 3413.

FIG. 35 shows memory device 3200 after a formation of doped regions 3501, material 3502, and select lines 3561, 3562, and 3563. Forming doped regions 3501 can include inserting (e.g., implanting) n-type impurities into selective portions of substrate portion 3271. Material 3502 (e.g., silicon oxide) can be formed on both sides of each device structure 3460 to electrically isolate select lines 3561, 3562, and 3563 from device structures 3460. Materials of select lines 3561, 3562, and 3563 can include one or more conductive materials, such as one or more metals, alloys, other conductive materials, or a combination thereof. Select lines 3561, 3562, and 3563 can correspond to select lines 261, 262, and 263 of memory device 3000 of FIG. 30.

FIG. 36 shows memory device 3200 after material 3601 have been formed in trenches 3411, 3412, and 3413. Forming material 3601 can include depositing dielectric material (e.g., silicon dioxide) to fill trenches 3411, 3412, and 3413. Then, a top portion of the dielectric material can be removed by, for example, etching back the conductive material or by CMP, stopping at substrate portion 3270.

FIG. 37 shows memory device 3200 after grooves 3701 have been formed by removing (e.g., by wet etching) a top portion of the material used to form select lines 3561, 3562, and 3563. Alternatively, forming grooves 3701 can be omitted.

FIG. 38 shows memory device 3200 after other components have been formed. The processes for forming the components of memory device 3200 in FIG. 38 can include similar or identical processes for forming the component of memory device 500 described above with reference to FIG. 10 through FIG. 29. For example, control gates 3821, 3822, and 3823 of FIG. 38 can be formed using processes similar to or identical to those of forming control gates 1221, 1222, and 1223 of memory device 500 described above with reference to FIG. 5 through FIG. 29. Data lines 3851, 3852, and 3853 of FIG. 38, can correspond to data lines 251, 252, and 253 of FIG. 30 and FIG. 31. As shown in FIG. 38, memory device 3200 can include memory cells 3810, 3811, and 3812, which can be formed using processes similar to or identical to those of forming memory cells 2910, 2911, and 2912 of memory device 500 described above with reference to FIG. 5 through FIG. 29.

One or more embodiments described herein include a memory device and methods of forming the memory device. One such memory device can include a first group of memory cells, each cell of the first group being formed in a respective cavity of a first control gate located in one device level of the memory device. The memory device also can include a second group of memory cells, each cell of the second group being formed in a cavity of in a second control gate located in another device level of the memory device. Additional apparatus and methods are described. Other embodiments including additional apparatus and methods are described above with reference to FIG. 1 through FIG. 38.

The illustrations of apparatus such as memory devices 100, 200, 500, 3000, and 3200, and memory cells 210, 211, 212, 2910, 2911, 2912, 3010, 3811, and 3812 are intended to

provide a general understanding of the structure of various embodiments and not a complete description of all the elements and features of the apparatus that might make use of the structures described herein.

The apparatus of various embodiments may include or be included in electronic circuitry used in high-speed computers, communication and signal processing circuitry, memory modules, portable memory storage devices (e.g., thumb drives), single or multi-processor modules, single or multiple embedded processors, multi-core processors, data switches, and application-specific modules including multi-layer, multi-chip modules. Such apparatus may further be included as sub-components within a variety of electronic systems, such as televisions, cellular telephones, personal computers (e.g., laptop computers, desktop computers, handheld computers, tablet computers, etc.), workstations, radios, video players, audio players (e.g., MP3 (Motion Picture Experts Group, Audio Layer 3) players), vehicles, medical devices (e.g., heart monitor, blood pressure monitor, etc.), set top boxes, and others.

The above description and the drawings illustrate some embodiments of the invention to enable those skilled in the art to practice the embodiments of the invention. Other embodiments may incorporate structural, logical, electrical, process, and other changes. Examples merely typify possible variations. Portions and features of some embodiments may be included in, or substituted for, those of others. Many other embodiments will be apparent to those of skill in the art upon studying and understanding the above description.

The Abstract is provided to comply with 37 C.F.R. § 1.72(b) requiring an abstract that will allow the reader to quickly ascertain the nature and gist of the technical disclosure. The Abstract of the Disclosure is submitted with the understanding that it will not be used to interpret or limit the scope or meaning of the claims.

What is claimed is:

1. An apparatus comprising:
  - conductive pillars extending outward from a substrate;
  - memory cell strings, each of the memory cell strings is formed over a respective conductive pillar of the conductive pillars;
  - a first control gate formed in a first device level, the memory cell strings including a memory cell string, the memory cell string including a first memory cell having a memory element formed in a cavity of the first control gate;
  - a second control gate formed in a second device level, the memory cell string including a second memory cell having a memory element formed in a cavity of the second control gate; and
  - a conductive channel extending between the first memory cell and the second memory cell and electrically coupled to a conductive pillar of the conductive pillars.
2. The apparatus of claim 1, further comprising:
  - a first conductive region located on a first side of the conductive pillar and separated from the conductive pillar by a first dielectric material; and
  - a second conductive region located on a second side opposite from the first side of the conductive pillar and separated from the conductive pillar by a second dielectric material.
3. The apparatus of claim 2, wherein the first conductive region is coupled to the second conductive region.
4. The apparatus of claim 2, wherein each of the first and second conductive regions comprises polysilicon.
5. The apparatus of claim 2, wherein each of the first and second conductive regions comprises metal.

6. The apparatus of claim 1, further comprising a data line coupled to the conductive channel, wherein the data line is located between the substrate and the first and second memory cells.

7. The apparatus of claim 1, further comprising a data line coupled to the conductive channel, wherein the first and second memory cells are located between the data line and the substrate.

8. The apparatus of claim 1, wherein the memory element comprises polysilicon.

9. The apparatus of claim 1, wherein the memory element comprises a dielectric material.

10. An apparatus comprising:

a first conductive pillar and a second conductive pillar extending outward from a substrate;

a first data line coupled to the first and second conductive pillars, the first data line located between the first and second conductive pillars and the substrate;

a third conductive pillar and a fourth conductive pillars extending outward from the substrate;

a second data line coupled to the third and fourth conductive pillars, the second data line located between the third and fourth conductive pillars and the substrate;

a first memory cell string formed over the first conductive pillar;

a second memory cell string formed over the second conductive pillar;

a third memory cell string formed over the third conductive pillar;

a fourth memory cell string formed over the fourth conductive pillar;

a first control gate formed in a first device level; and a second control gate formed in a second device level, wherein,

the first memory cell string includes a first memory cell having a memory element formed in a first cavity of the first control gate, and a second memory cell having a memory element formed in a first cavity of the second control gate;

the second memory cell string includes a third memory cell having a memory element formed in a second cavity of the first control gate, and a fourth memory cell having a memory element formed in a second cavity of the second control gate;

the third memory cell string includes a fifth memory cell having a memory element formed in a third cavity of the first control gate, and a sixth memory cell having a memory element formed in a third cavity of the second control gate; and

the fourth memory cell string includes a seventh memory cell having a memory element formed in a fourth cavity of the first control gate, and an eighth memory cell having a memory element formed in a fourth cavity of the second control gate.

11. The apparatus of claim 10, further comprising:

a first conductive channel coupled to the first conductive pillar and extending between the first and second memory cells;

a second conductive channel coupled to the second conductive pillar and extending between the third and fourth memory cells;

a third conductive channel coupled to the third conductive pillar and extending between the fifth and sixth memory cells; and

a fourth conductive channel coupled to the fourth conductive pillar and extending between the seventh and eighth memory cells.

15

12. The apparatus of claim 10, further comprising a first conductive gate including a first segment and a second segment coupled to the first segment, wherein:

the first segment is located on a first side of each of the first and third conductive pillars and separated from the first and third conductive pillars by a first dielectric material; and

the second segment is located on a second side of each of the first and third conductive pillars and separated from the first and third conductive pillars by a second dielectric material.

13. The apparatus of claim 12, further comprising a second conductive gate including a third a segment and a fourth segment coupled to the third segment, wherein:

the third segment is located on a first side of each of the second and fourth conductive pillars and separated from the second and fourth conductive pillars by a third dielectric material; and

the fourth segment is located on a second side of each of the second and fourth conductive pillars and separated from the second and fourth conductive pillars by a fourth dielectric material.

14. The apparatus of claim 13, wherein each of the first and second conductive gates comprises polysilicon.

15. The apparatus of claim 13, wherein each of the first and second conductive gates comprises metal.

16. The apparatus of claim 10, wherein the memory element of each of the first, second, third, and fourth memory cells comprises one of polysilicon and a dielectric material.

17. An apparatus comprising:

a first conductive pillar and a second conductive pillar extending outward from a substrate;

a third conductive pillar and a fourth conductive pillars extending outward from the substrate;

a region including a conductive material, the region coupled to the first, second, third, and fourth conductive pillars, the region located between substrate and the first, second, third, and fourth conductive pillars;

a first memory cell string formed over the first conductive pillar;

a second memory cell string formed over the second conductive pillar;

a third memory cell string formed over the third conductive pillar;

a fourth memory cell string formed over the fourth conductive pillar;

16

a first data line coupled to the first and second memory cell strings, the first and second memory cell strings located between the first data line and the substrate;

a second data line coupled to the third and fourth memory cell strings, the third and fourth memory cell strings located between the second data line and the substrate;

a first control gate formed in a first device level;

a second control gate formed in a second device level, wherein, the first memory cell string includes a first memory cell having a memory element formed in a first cavity of the first control gate, and a second memory cell having a memory element formed in a first cavity of the second control gate;

the second memory cell string includes a third memory cell having a memory element formed in a second cavity of the first control gate, and a fourth memory cell having a memory element formed in a second cavity of the second control gate;

the third memory cell string includes a fifth memory cell having a memory element formed in a third cavity of the first control gate, and a sixth memory cell having a memory element formed in a third cavity of the second control gate; and

the fourth memory cell string includes a seventh memory cell having a memory element formed in a fourth cavity of the first control gate, and an eighth memory cell having a memory element formed in a fourth cavity of the second control gate.

18. The apparatus of claim 17, wherein the memory element of each of the first, second, third, and fourth memory cells comprises polysilicon.

19. The apparatus of claim 17, wherein the memory element of each of the first, second, third, and fourth memory cells comprises a silicon nitride.

20. The apparatus of claim 17, further comprising: a first conductive channel coupled to the first conductive pillar and extending between the first and second memory cells;

a second conductive channel coupled to the second conductive pillar and extending between the third and fourth memory cells;

a third conductive channel coupled to the third conductive pillar and extending between the fifth and sixth memory cells; and

a fourth conductive channel coupled to the fourth conductive pillar and extending between the seventh and eighth memory cells.

\* \* \* \* \*