

(12) **United States Patent**
Leaper

(10) **Patent No.:** **US 12,036,174 B1**
(45) **Date of Patent:** **Jul. 16, 2024**

(54) **COMMUNICATION DEVICES, METHODS, AND SYSTEMS**

(71) Applicant: **DATAFEEL INC.**, Washington, DC (US)

(72) Inventor: **Matthew Robert Leaper**, Omaha, NE (US)

(73) Assignee: **DATAFEEL INC.**, Washington, DC (US)

(*) Notice: Subject to any disclaimer, the term of this patent is extended or adjusted under 35 U.S.C. 154(b) by 0 days.

(21) Appl. No.: **18/526,980**

(22) Filed: **Dec. 1, 2023**

Related U.S. Application Data

(63) Continuation of application No. 18/388,489, filed on Nov. 9, 2023, now Pat. No. 11,931,174, which is a (Continued)

(51) **Int. Cl.**
A61B 5/11 (2006.01)
A61B 5/00 (2006.01)
(Continued)

(52) **U.S. Cl.**
CPC *A61H 23/006* (2013.01); *A61B 5/486* (2013.01); *A61H 23/02* (2013.01); *A61N 1/0456* (2013.01);
(Continued)

(58) **Field of Classification Search**
CPC ... *A61B 5/0022*; *A61B 5/1112*; *A61B 5/1114*; *A61B 5/318*; *A61B 5/4029*;
(Continued)

(56) **References Cited**

U.S. PATENT DOCUMENTS

2,088,780 A 8/1937 Follse
2,327,222 A 8/1943 Sell
(Continued)

FOREIGN PATENT DOCUMENTS

AU 2015202395 A1 5/2015
EP 0556999 A1 8/1993
(Continued)

OTHER PUBLICATIONS

Ashley Carman, "This ring will vibrate in coordination with your loved one's pulse; They're alive! And not answering your texts!," Circuit Breaker, The Verge, Aug. 10, 2016, <https://www.theverge.com/circuitbreaker/2016/8/10/12423956/thetouch-hb-ring-heartrate-pulse>.

(Continued)

Primary Examiner — Mark R Gaworecki

(57) **ABSTRACT**

Exemplary aspects of a treatment device are described, such as a body and a plurality of energy generator elements. The body may be provided with a processing unit and a power source. The plurality of energy generator elements may be independently operable to convert electricity from the power source into a plurality of different energy types transmittable towards an area of skin of a user. The plurality of energy generator elements may be arranged coaxially about an axis. The body may include a grip arranged to be grasped by a hand of the user applying a gripping force to maintain the plurality of energy generator elements on or adjacent the area of skin. Related apparatus, methods, and systems are described.

28 Claims, 14 Drawing Sheets

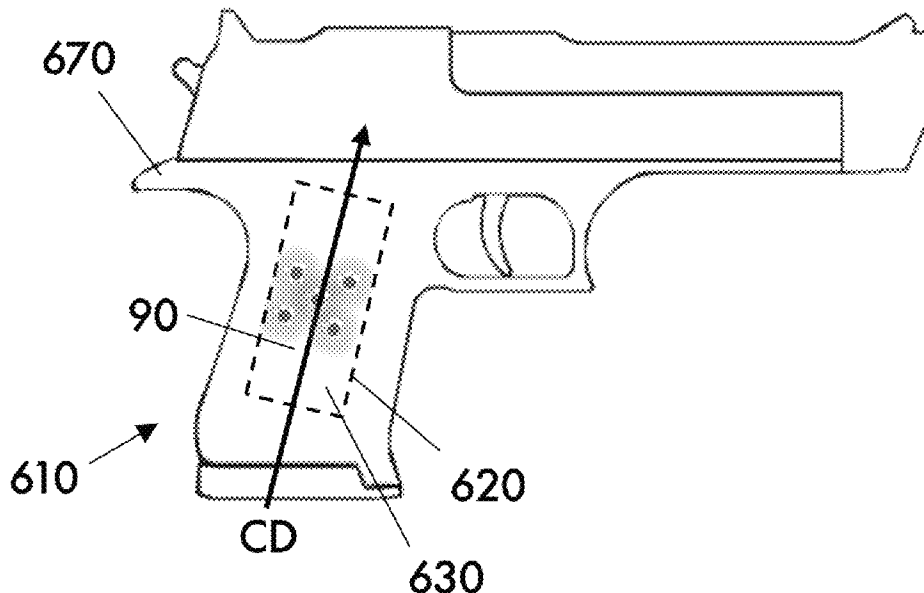

Related U.S. Application Data

continuation of application No. 18/143,142, filed on May 4, 2023, now Pat. No. 11,864,914, which is a continuation of application No. 18/092,398, filed on Jan. 2, 2023, now Pat. No. 11,684,313, which is a continuation of application No. 17/213,117, filed on Mar. 25, 2021, now Pat. No. 11,589,816, which is a continuation of application No. 16/757,482, filed as application No. PCT/US2018/056814 on Oct. 22, 2018, now Pat. No. 10,959,674.

(60) Provisional application No. 62/676,949, filed on May 26, 2018, provisional application No. 62/575,951, filed on Oct. 23, 2017.

(51) **Int. Cl.**

A61H 23/00 (2006.01)
A61H 23/02 (2006.01)
A61N 1/04 (2006.01)
A61N 1/36 (2006.01)
G06F 3/01 (2006.01)

(52) **U.S. Cl.**

CPC *A61N 1/36014* (2013.01); *A61B 5/7435* (2013.01); *A61H 2201/0153* (2013.01); *A61H 2201/0207* (2013.01); *A61H 2201/123* (2013.01); *A61H 2201/1664* (2013.01); *A61H 2205/065* (2013.01); *A61H 2230/065* (2013.01)

(58) **Field of Classification Search**

CPC ... A61B 5/4824; A61B 5/4836; A61B 5/4848; A61B 5/486; A61B 5/6803; A61B 5/6807; A61B 5/681; A61B 5/6824; A61B 5/6833; A61B 5/7435; A61B 2503/12; A61B 2560/0214; A61B 2560/0412; A61B 2560/0468; A61B 2562/046; A61B 2562/164; A61N 1/0456; A61N 1/0484; A61N 1/0492; A61N 1/36014; A61N 1/3603; G06F 3/016; A61H 23/006; A61H 23/02; A61H 2201/0153; A61H 2201/0207; A61H 2201/123; A61H 2201/1664; A61H 2205/065; A61H 2230/065

See application file for complete search history.

(56)

References Cited

U.S. PATENT DOCUMENTS

3,108,268 A 10/1963 Uttal
 3,594,787 A 7/1971 Ickes
 3,848,608 A 11/1974 Leonard
 4,167,189 A 9/1979 Tachi et al.
 4,428,368 A 1/1984 Torii
 4,510,939 A 4/1985 Brenman et al.
 4,535,784 A 8/1985 Rohlicek et al.
 4,573,481 A 3/1986 Bullara
 4,612,934 A 9/1986 Borkan
 4,628,933 A 12/1986 Michelson
 4,651,716 A 3/1987 Forester et al.
 4,676,246 A 6/1987 Korenaga
 4,837,049 A 6/1989 Byers et al.
 4,885,565 A 12/1989 Embach
 4,926,879 A 5/1990 Sevrain et al.
 4,930,504 A 6/1990 Diamantopoulos et al.
 5,024,236 A 6/1991 Shapiro
 5,050,587 A 9/1991 Sagara et al.
 5,109,844 A 5/1992 De Juan et al.
 5,150,704 A 9/1992 Tatebayashi et al.
 5,165,897 A 11/1992 Johnson
 5,175,459 A 12/1992 Danial et al.
 5,215,088 A 6/1993 Normann et al.

5,259,380 A 11/1993 Mendes et al.
 5,272,716 A 12/1993 Soltz et al.
 5,300,097 A 4/1994 Lerner et al.
 5,304,207 A 4/1994 Stromer
 5,327,886 A 7/1994 Chiu
 5,358,503 A 10/1994 Bertwell et al.
 5,385,503 A 1/1995 Stouffer et al.
 5,436,622 A 7/1995 Gutman et al.
 5,449,378 A 9/1995 Schouenborg
 5,464,436 A 11/1995 Smith
 5,549,660 A 8/1996 Mendes et al.
 5,551,949 A 9/1996 Kim
 5,553,148 A 9/1996 Werle
 5,569,307 A 10/1996 Schulman et al.
 5,575,761 A 11/1996 Hajianpour
 5,578,065 A 11/1996 Hattori et al.
 5,616,140 A 4/1997 Prescott
 5,627,548 A 5/1997 Woo et al.
 5,665,053 A 9/1997 Jacobs
 5,719,561 A 2/1998 Gonzales
 5,776,233 A 7/1998 Wiedemann et al.
 5,779,483 A 7/1998 Cho
 5,800,479 A 9/1998 Thiberg
 5,843,074 A 12/1998 Cocilovo
 5,865,771 A 2/1999 Shuto et al.
 5,876,427 A 3/1999 Chen et al.
 5,895,348 A 4/1999 Hosaka
 5,913,883 A 6/1999 Alexander et al.
 5,935,155 A 8/1999 Humayun et al.
 5,944,748 A 8/1999 Mager et al.
 5,948,006 A 9/1999 Mann
 5,957,569 A 9/1999 Helbig et al.
 5,957,960 A 9/1999 Chen et al.
 6,038,485 A 3/2000 Axelgaard
 6,045,575 A 4/2000 Rosen et al.
 6,063,108 A 5/2000 Salansky et al.
 6,074,411 A 6/2000 Lai et al.
 6,096,066 A 8/2000 Chen et al.
 6,099,554 A 8/2000 Nordquist et al.
 6,104,820 A 8/2000 Soza
 6,107,466 A 8/2000 Hasan et al.
 6,156,028 A 12/2000 Prescott
 6,228,103 B1 5/2001 Grey et al.
 6,275,213 B1 8/2001 Tremblay et al.
 6,277,085 B1 8/2001 Flynn
 6,400,989 B1 6/2002 Eckmiller
 6,402,739 B1 6/2002 Neev
 6,413,230 B1 7/2002 Haupt et al.
 6,458,157 B1 10/2002 Suaning
 6,547,788 B1 4/2003 Maguire et al.
 6,712,613 B2 3/2004 Depta
 6,735,480 B2 5/2004 Giuntoli et al.
 6,819,312 B2 11/2004 Fish
 6,889,090 B2 5/2005 Kreindel
 7,013,179 B2 3/2006 Carter et al.
 7,077,858 B2 7/2006 Fletcher et al.
 7,081,128 B2 7/2006 Hart et al.
 7,110,820 B2 9/2006 Tchong et al.
 7,113,177 B2 9/2006 Franzen
 7,182,739 B2 2/2007 Kopanic et al.
 7,238,162 B2 7/2007 Dehli
 7,241,291 B2 7/2007 Kreindel et al.
 7,324,094 B2 1/2008 Moilanen et al.
 7,336,266 B2 2/2008 Hayward et al.
 7,390,157 B2 6/2008 Kramer
 7,615,015 B2 11/2009 Glen
 7,687,678 B2 3/2010 Jacobs
 7,696,860 B2 4/2010 Gilson et al.
 7,722,655 B2 5/2010 Lee
 7,771,374 B2 8/2010 Slatkine
 7,818,061 B1 10/2010 Palmer
 7,825,903 B2 11/2010 Anastas et al.
 7,988,649 B1 8/2011 Kost
 8,013,847 B2 9/2011 Anastas
 8,027,491 B2 9/2011 LeDonne
 8,139,803 B2 3/2012 Afshar
 8,147,533 B2 4/2012 Baxter et al.
 8,157,753 B2 4/2012 Nichols
 8,170,656 B2 5/2012 Tan et al.

(56)

References Cited

U.S. PATENT DOCUMENTS

8,175,718 B2	5/2012	Wahlgren et al.	9,940,811 B2	4/2018	Chang et al.
8,203,529 B2	6/2012	Rogowitz et al.	9,943,698 B2	4/2018	Chase et al.
8,308,558 B2	11/2012	Thorner	9,950,147 B2	4/2018	Mehta
8,316,166 B2	11/2012	Grant et al.	9,961,435 B1	5/2018	Goyal et al.
8,362,882 B2	1/2013	Heubel et al.	10,019,912 B2	7/2018	Eagleman et al.
8,364,257 B2	1/2013	Eerenbeemd et al.	10,039,928 B2	8/2018	Hyde et al.
8,369,944 B2	2/2013	Macho et al.	10,058,476 B2	8/2018	Baxter et al.
8,552,847 B1	10/2013	Hill	10,070,799 B2	9/2018	Ang et al.
8,632,576 B2	1/2014	Quisenberry	10,080,906 B2	9/2018	Schwarz et al.
8,633,907 B2	1/2014	Mahalingam	10,111,010 B2	10/2018	Alexiou et al.
8,686,951 B2	4/2014	Vartanian et al.	10,123,937 B2	11/2018	Pisharodi et al.
8,696,357 B2	4/2014	AlDossary	10,181,331 B2	1/2019	Eagleman et al.
8,702,769 B2	4/2014	Eckhouse et al.	10,198,076 B2	2/2019	Eagleman et al.
8,711,118 B2	4/2014	Short et al.	10,200,332 B2	2/2019	Wu et al.
8,740,960 B2	6/2014	Baxter et al.	10,216,278 B2	2/2019	Nakamura et al.
8,766,786 B2	7/2014	Radivojevic	10,234,934 B2	3/2019	Connor
8,767,996 B1	7/2014	Lin et al.	10,255,771 B2	4/2019	Baron et al.
8,917,167 B1	12/2014	Selker	10,275,029 B2	4/2019	Jones et al.
8,922,503 B2	12/2014	Ciesla et al.	10,285,902 B2	5/2019	Pamplin et al.
8,965,500 B2	2/2015	Macho et al.	10,321,873 B2	6/2019	Connor
8,979,775 B2	3/2015	Schafer et al.	10,371,544 B2	8/2019	Yoo et al.
9,008,794 B2	4/2015	Alexandre	10,384,076 B2	8/2019	Wagenaar et al.
9,024,874 B2	5/2015	Stetten et al.	10,437,340 B1	10/2019	Sullivan
9,042,971 B2	5/2015	Brumback et al.	10,456,604 B2	10/2019	Cheatham, III et al.
9,046,919 B2	6/2015	Niknejad	10,524,978 B2	1/2020	Marton et al.
9,053,617 B2	6/2015	Ramstein et al.	10,589,087 B2	3/2020	Tyler et al.
9,064,387 B2	6/2015	Bhatia et al.	10,625,074 B2	4/2020	Rosenbluth et al.
9,078,065 B2	7/2015	Karam et al.	10,699,538 B2	6/2020	Novich et al.
9,083,821 B2	7/2015	Hughes	10,748,448 B2	8/2020	Knott et al.
9,092,953 B1	7/2015	Mortimer et al.	10,888,708 B2	1/2021	Stephens et al.
9,092,954 B2	7/2015	Visitacion et al.	10,945,878 B2	3/2021	Deng et al.
9,095,359 B2	8/2015	Behnke et al.	11,247,039 B2	2/2022	Prouza et al.
9,170,650 B2	10/2015	Ramstein et al.	11,253,717 B2	2/2022	Schwarz et al.
9,195,350 B2	11/2015	Radivojevic et al.	11,439,841 B2	9/2022	Zimmerman
9,198,792 B2	12/2015	Skahan et al.	11,464,993 B2	10/2022	Schwarz et al.
9,213,408 B2	12/2015	Gandhi et al.	11,701,253 B2	7/2023	Black et al.
9,254,382 B2	2/2016	Ahmad et al.	11,712,367 B2	8/2023	Simons et al.
9,274,603 B2	3/2016	Modarres et al.	2001/0043847 A1	11/2001	Kramer
9,282,893 B2	3/2016	Longinotti-Buitoni et al.	2002/0143373 A1	10/2002	Courtneage et al.
9,295,607 B2	3/2016	Rosenberg	2003/0023297 A1	1/2003	Byers et al.
9,308,363 B2	4/2016	Goroszeniuk et al.	2003/0032900 A1	2/2003	Ella
9,311,792 B2	4/2016	Kosonen et al.	2003/0083599 A1	5/2003	Kitov
9,314,650 B2	4/2016	Rosenberg et al.	2003/0153961 A1	8/2003	Babaev
9,333,144 B2	5/2016	Baxter et al.	2003/0181116 A1	9/2003	Heerden et al.
9,333,377 B2	5/2016	Rosenberg	2003/0212350 A1	11/2003	Tadlock
9,364,667 B1	6/2016	Dinsmoor et al.	2003/0187488 A1	12/2003	Kreindel et al.
9,375,345 B2	6/2016	Levinson et al.	2004/0039254 A1	2/2004	Stivoric et al.
9,407,130 B2	8/2016	Garcia et al.	2004/0040800 A1	3/2004	Anastas et al.
9,408,316 B2	8/2016	Bailey et al.	2004/0082886 A1	4/2004	Timpson
9,417,694 B2	8/2016	Birnbaum et al.	2004/0210122 A1	10/2004	Sieburg
9,454,915 B2	9/2016	Aldossary et al.	2004/0241623 A1	12/2004	Lenay et al.
9,466,187 B2	10/2016	Grant et al.	2004/0260211 A1	12/2004	Maalouf
9,468,847 B2	10/2016	Bekri	2005/0078846 A1	4/2005	Single
9,504,826 B2	11/2016	Flyash et al.	2005/0177093 A1	8/2005	Barry et al.
9,553,625 B2	1/2017	Hatanaka et al.	2006/0036201 A1	2/2006	Cohen
9,561,357 B2	2/2017	Hall et al.	2006/0041207 A1	2/2006	Gross
9,582,034 B2	2/2017	Badinski et al.	2006/0052695 A1	3/2006	Adam
9,582,035 B2	2/2017	Connor	2006/0116611 A1	6/2006	Richter
9,582,072 B2	2/2017	Connor	2006/0135890 A1	6/2006	Tsai
9,585,687 B2	3/2017	Tenenbaum et al.	2006/0247754 A1	11/2006	Greenberg et al.
9,607,492 B2	3/2017	Churovich	2006/0264926 A1	11/2006	Kochamba
9,619,034 B2	4/2017	Birnbaum et al.	2007/0010810 A1	1/2007	Kochamba
9,623,907 B2	4/2017	Marti et al.	2007/0016425 A1	1/2007	Ward
9,626,845 B2	4/2017	Eagleman et al.	2007/0027411 A1	2/2007	Ella et al.
9,652,946 B2	5/2017	Ramstein et al.	2007/0063849 A1	3/2007	Rosella et al.
9,669,233 B2	6/2017	Quisenberry et al.	2007/0255187 A1	11/2007	Branch
9,672,701 B2	6/2017	Evreinov et al.	2007/0255355 A1	11/2007	Altshuler et al.
9,672,791 B2	6/2017	Kapinos et al.	2008/0014011 A1	1/2008	Rossen
9,703,381 B2	7/2017	Gallo et al.	2008/0023597 A1	1/2008	Wyner et al.
9,754,078 B2	9/2017	Ramsay et al.	2008/0188911 A1	8/2008	Chao
9,754,464 B1	9/2017	Sinkov	2008/0195000 A1	8/2008	Spooner et al.
9,829,977 B2	11/2017	Heubel et al.	2008/0215039 A1	9/2008	Slatkine et al.
9,884,179 B2	2/2018	Bouton et al.	2008/0312647 A1	12/2008	Knopp et al.
9,898,085 B2	2/2018	Saboune et al.	2009/0048547 A1	2/2009	Chen
9,936,900 B2	4/2018	Chang et al.	2009/0076421 A1	3/2009	Grant, Jr.
			2009/0098519 A1	4/2009	Byerly
			2009/0112134 A1	4/2009	Avni
			2009/0120105 A1	5/2009	Ramsay et al.
			2009/0131840 A1	5/2009	Lee

(56)

References Cited

FOREIGN PATENT DOCUMENTS

JP	6178566	B2	8/2017
JP	6652164	B2	2/2020
JP	2022050711	A	2/2023
KR	100746214	B1	8/2007
KR	101064115	B1	9/2011
KR	20120018245	A	3/2012
KR	101315403	B1	10/2013
KR	101319429	B1	10/2013
KR	101767485	B1	8/2017
WO	0240095	A1	5/2002
WO	2013118122	A1	8/2013
WO	2014117125	A1	7/2014
WO	2015083183	A1	6/2015
WO	2016019250	A1	2/2016
WO	2017158583	A1	9/2017
WO	2017173436	A1	10/2017
WO	2018013835	A1	1/2018
WO	2018048907	A1	3/2018
WO	2018143418	A1	8/2018

OTHER PUBLICATIONS

David Eagleman, "Can we create new senses for humans?," Transcript of TED Talk, available at: https://www.ted.com/talks/david_eagleman_can_we_create_new_senses_for_humans/transcript?language=en (last accessed May 17, 2022).

International Preliminary Report on Patentability for International Patent Application No. PCT/US18/56814, dated Apr. 1, 2020 (50 pages).

International Search Report and Written Opinion for International Patent Application No. PCT/US18/56814, mailed Feb. 22, 2019 (21 pages).

Iwamoto et al., "Non-contact Method for Producing Tactile Sensation Using Airborne Ultrasound", Eurohaptics 2008, LNCS 5024, pp. 504-513, http://www.researchgate.net/publication/221011909_Non-contact_Method_for_Producing_Tactile_Sensation_Using_Airborne_Ultrasound.

Maereg et al., "Wearable Vibrotactile Haptic Device for Stiffness Discrimination during Virtual Interactions," Journal of Frontiers in Robotics and AI, vol. 4, 2017, <https://www.frontiersin.org/article/10.3389/frobt.2017.00042>.

Novich et al., "Using space and time to encode vibrotactile information: toward an estimate of the skin's achievable throughput," Experimental Brain Research, 233, p. 2777-2788(2015). available at: [Http://link.springer.com/article/10.1007/s00221-015-4346-1](http://link.springer.com/article/10.1007/s00221-015-4346-1).

Seneviratne et al., "A Survey of Wearable Devices and Challenges," Article, IEEE Communications Surveys & tutorials, Jul. 2017, (52 pages), (99)1-1, available at: http://www.researchgate.net/publications/318717275_A_Survey_of_Wearable_Devices_and_Challenges.

Shull et al., "Haptic wearables as sensory replacement, sensory augmentation and trainer—a review," Journal of NeuroEngineering and Rehabilitation, vol. 12, Article #59, 2015, <https://doi.org/10.1186/s12984-015-0055-z>.

Supplemental European Search Report for European Patent App. No. EP18871368.9 (European national stage entry of PCT/US18/56814), mailed on Sep. 10, 2021 (2 pages).

Singhal, Anshul et al., Perceptual Interactions in thermo-tactile displays, Jun. 2017, 5 pages, 2017 Institute of Electrical and Electronics Engineers (IEEE) World Haptics Conference, Munich, Germany, Jun. 6-9, 2017.

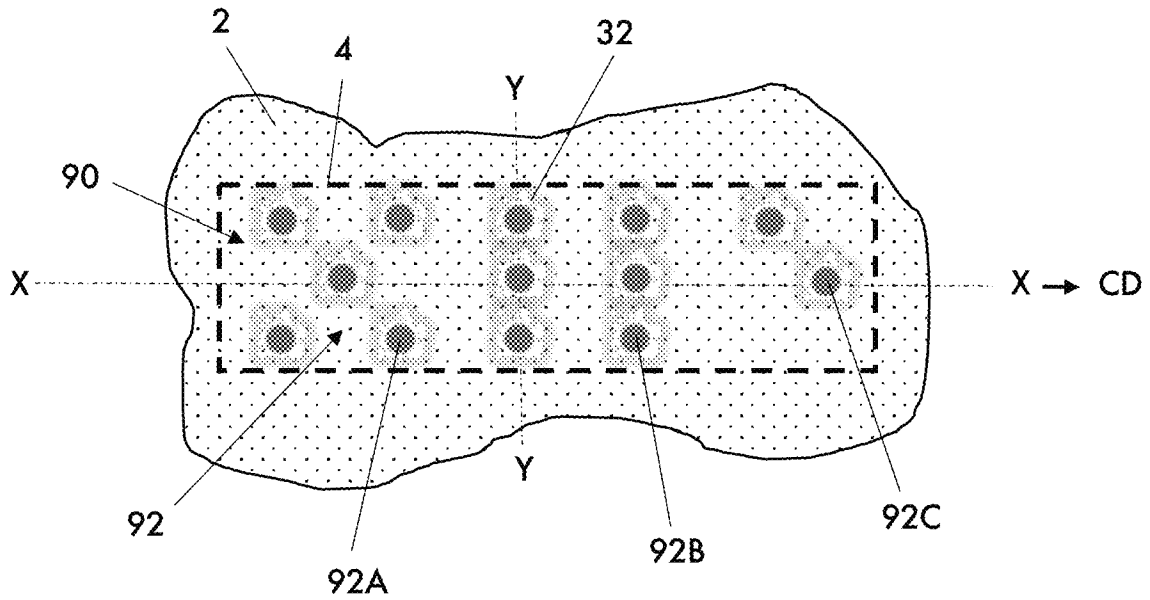

FIG. 1A

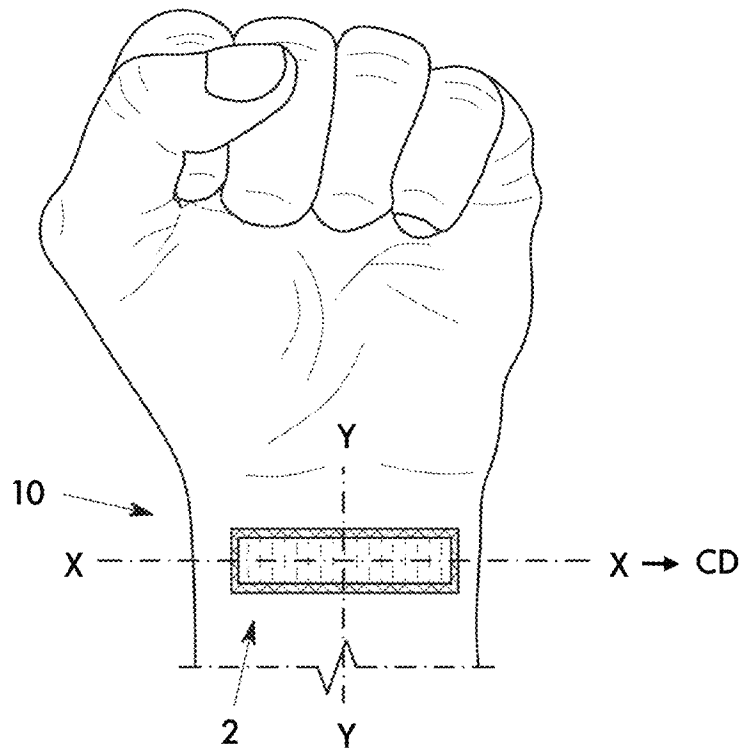

FIG. 1B

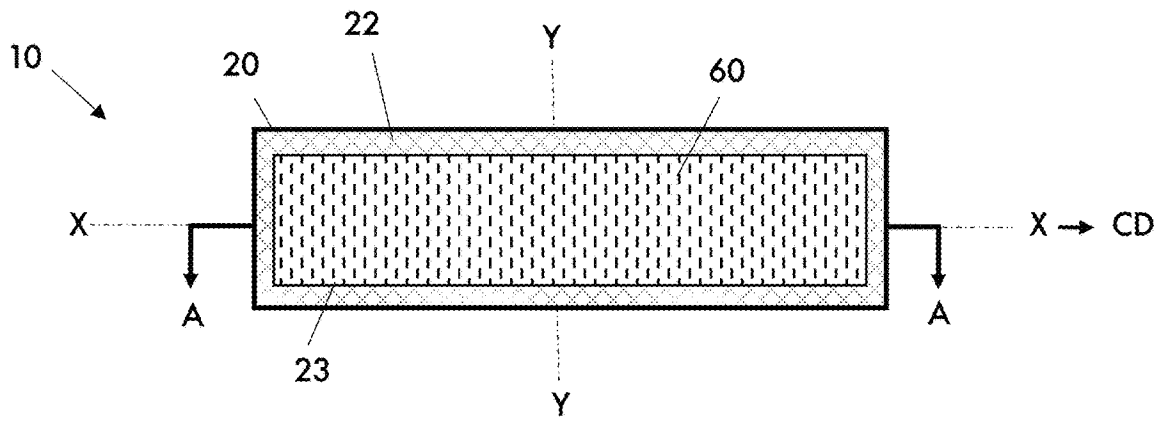

FIG. 2A

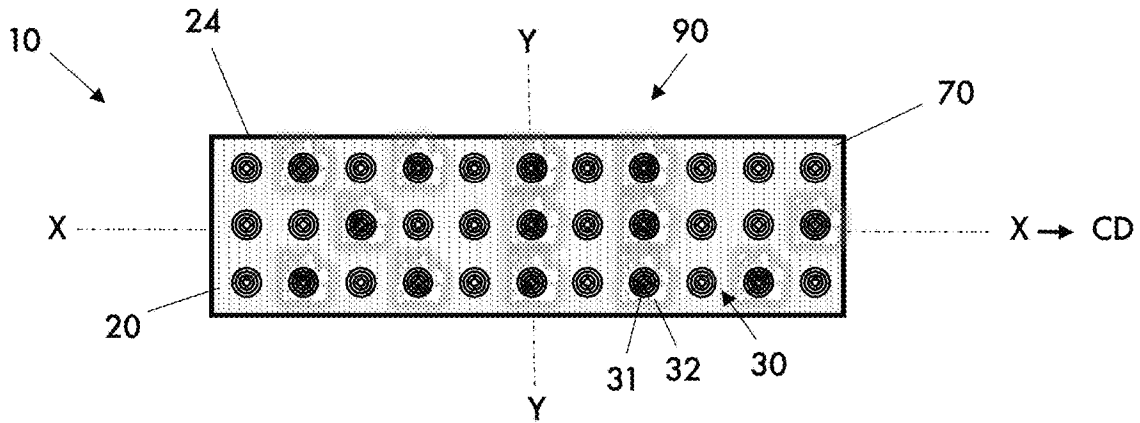

FIG. 2B

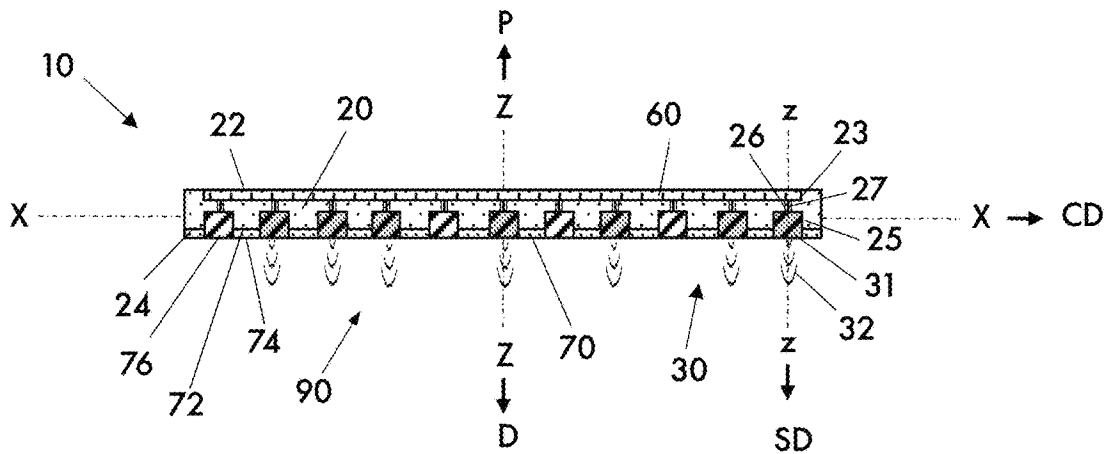

FIG. 2C

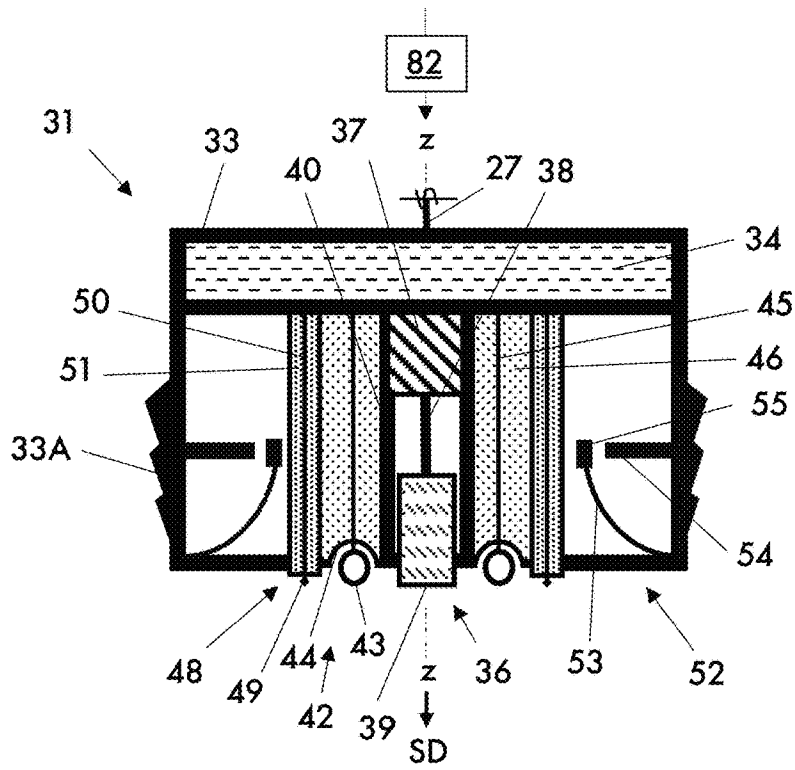

FIG. 3A

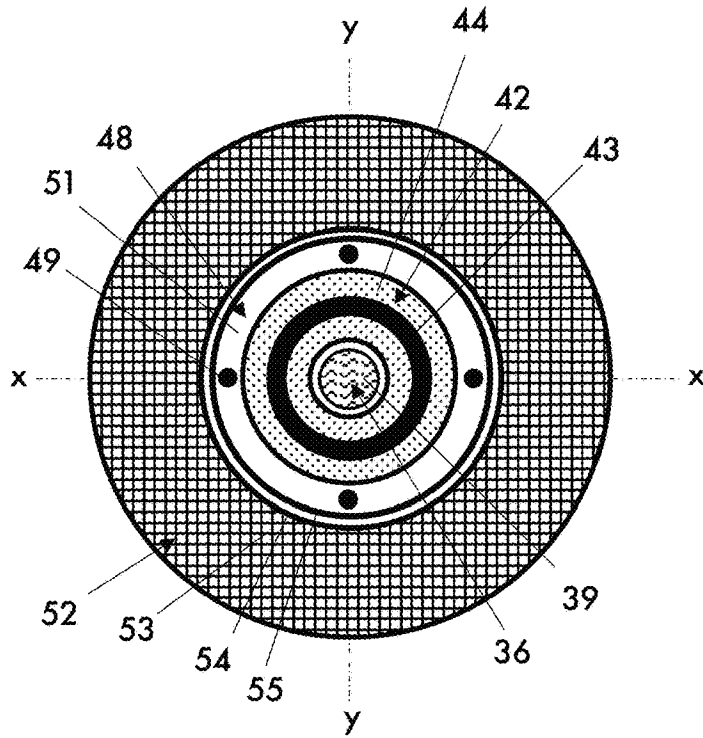

FIG. 3B

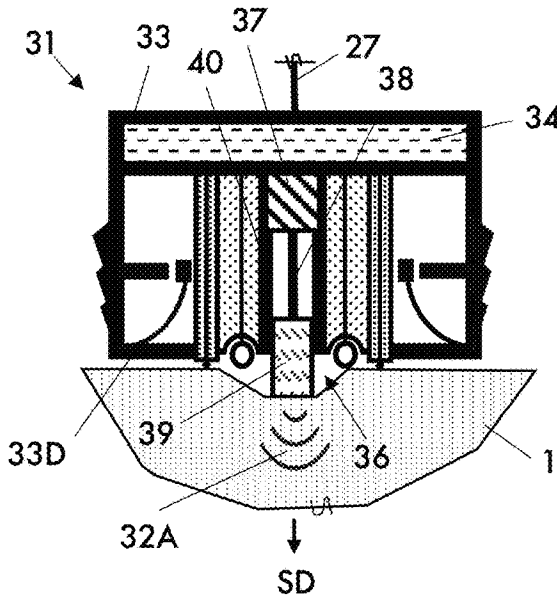

FIG. 4A

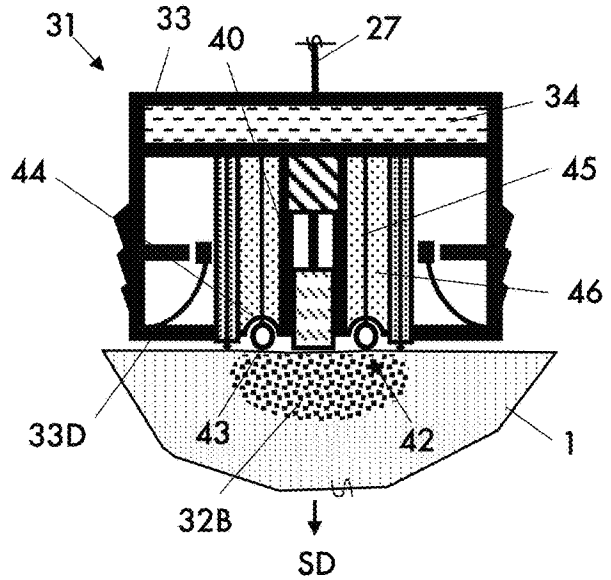

FIG. 4B

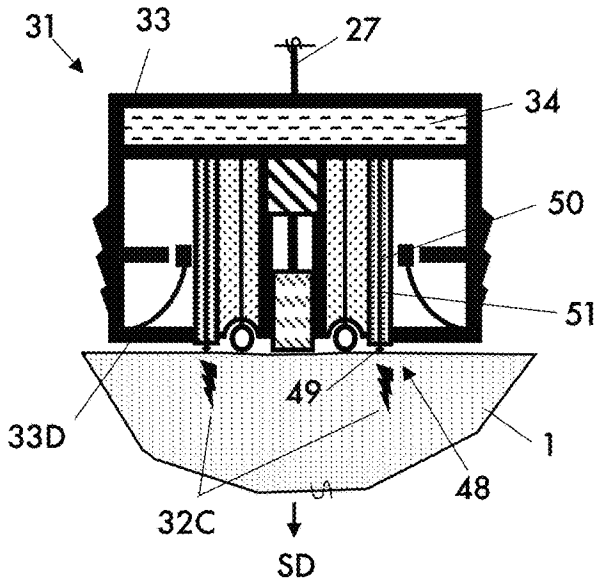

FIG. 4C

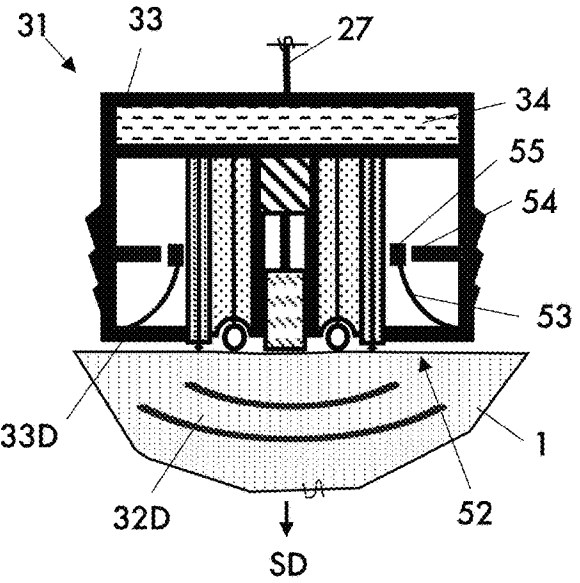

FIG. 4D

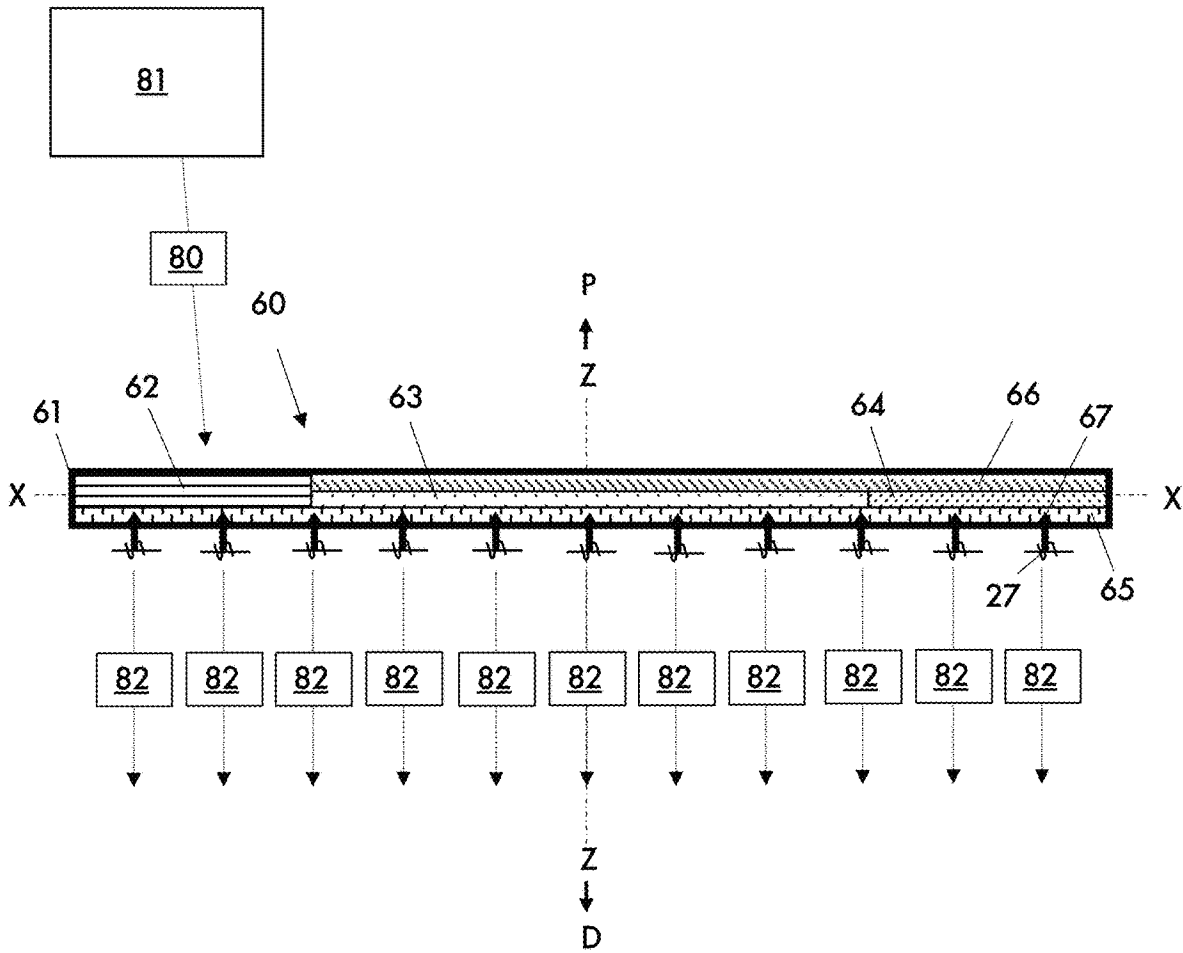

FIG. 5

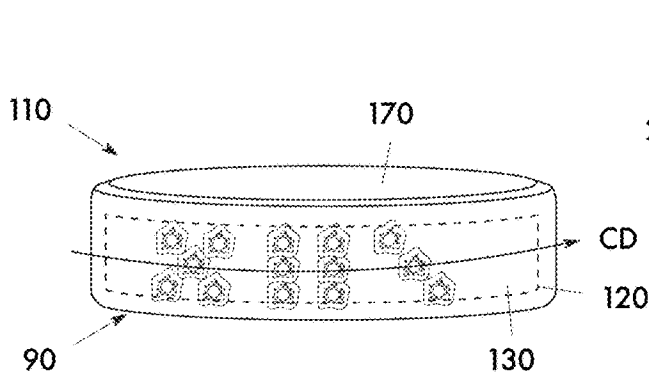

FIG. 6A

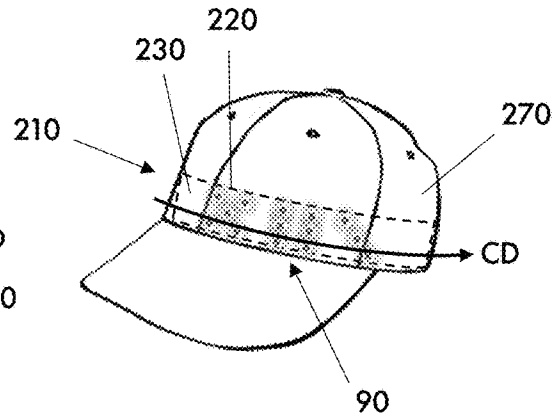

FIG. 6B

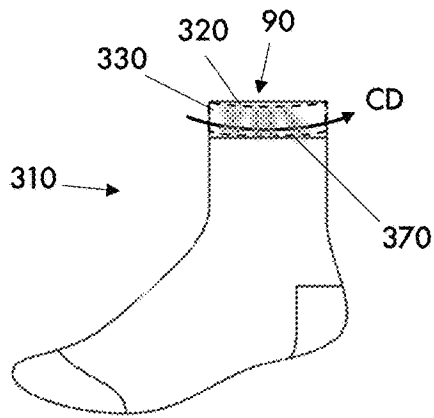

FIG. 6C

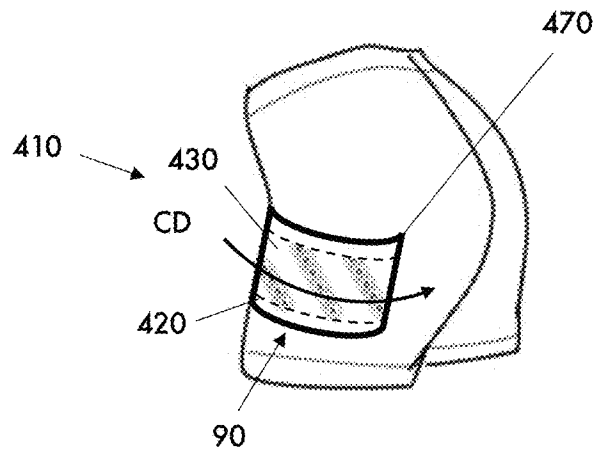

FIG. 6D

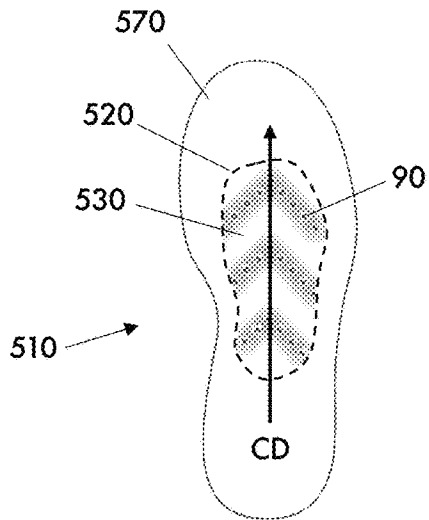

FIG. 7A

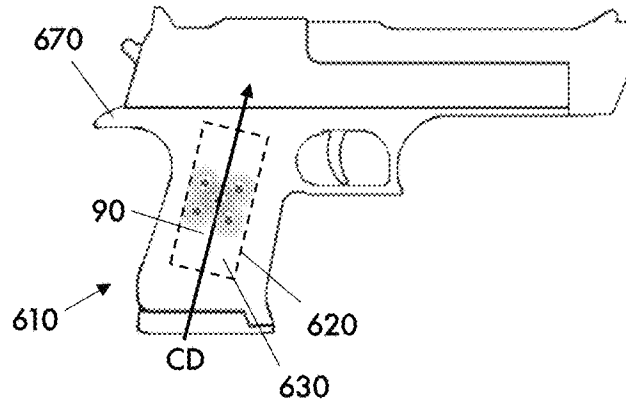

FIG. 7B

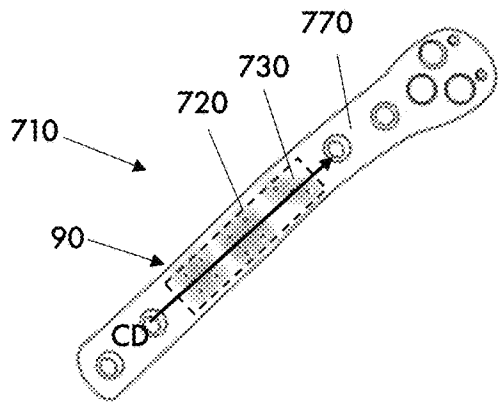

FIG. 7C

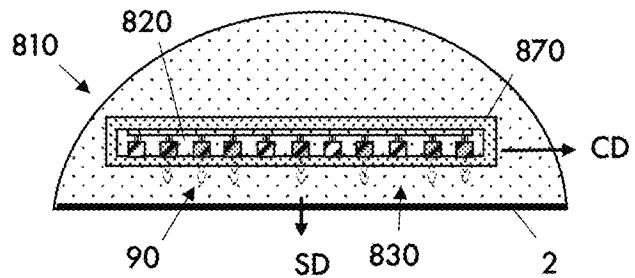

FIG. 7D

1000

```
graph TD; 1000 --> 1020; 1020 --> 1040;
```

1020: Receiving, with a processing unit, input data for a communication device including a tissue interface maintainable on or adjacent skin, the interface including a plurality of energy generators, each generator being operable to output a plurality of energies in a signal direction toward the skin.

1040: Operating, with the processing unit, the plurality of energy generators to communicate with nerves associated with the skin by outputting one or more energies of the plurality of energies in the signal direction based on the input data.

FIG. 9

1100

```
graph TD; 1100 --> 1120; 1120 --> 1140;
```

1120: Receiving, with a processing unit, input data for a communication device including a tissue interface maintainable on or adjacent skin, the interface including a plurality of energy generators arranged in bands or divided areas, each generator being operable to output a plurality of energies in a signal direction toward the skin.

1140: Operating, with the processing unit, the plurality of energy generators in each band or divided area to communicate with nerves associated with the skin by outputting one or more energies of the plurality of energies in response to the input data.

FIG. 10

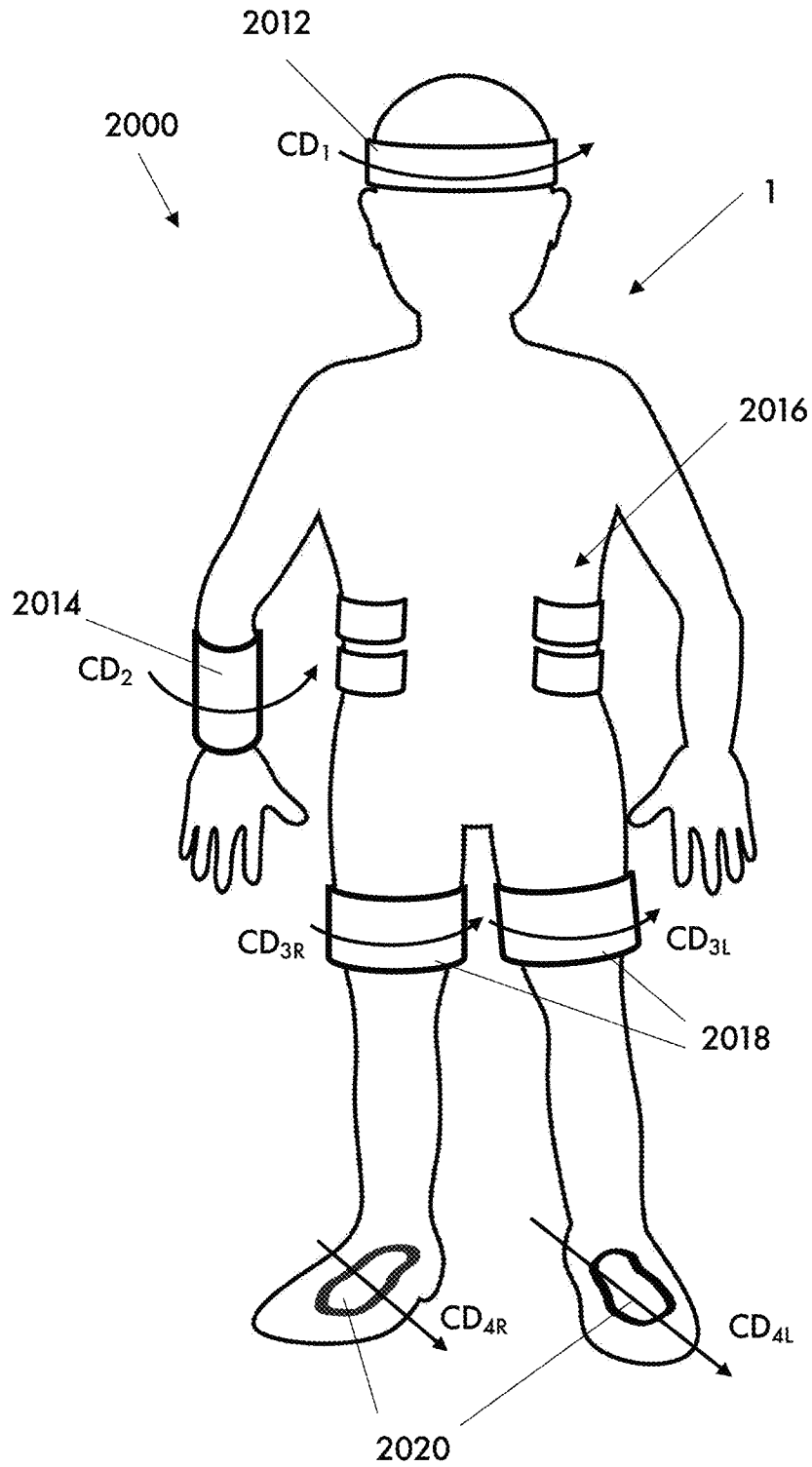

FIG. 11

2100

```
graph TD; 2100 --> 2120; 2120 --> 2140; 2140 --> 2160;
```

2120: Receiving, with one or more processors, position data for a plurality of communication devices mountable on or adjacent skin, each device including a tissue interface with a plurality of energy generators, each generator being operable to output a plurality of energies in a signal direction toward the skin.

2140: Receiving or generating, with the one or more processors, a corrective motion signal for the plurality of communication devices based on position data for each communication device.

2160: Operating, with the one or more processors, the plurality of energy generators of each communication device to output one or more energies of the plurality of energies in the signal direction based on the corrective motion signal.

FIG. 12

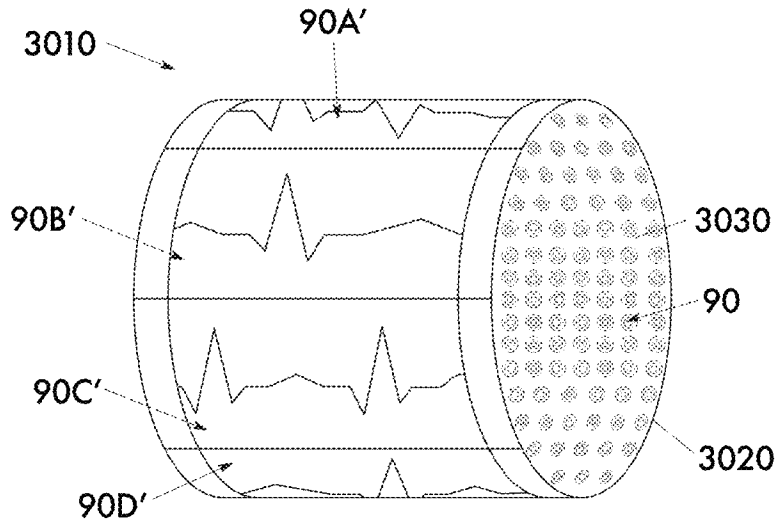

FIG. 14A

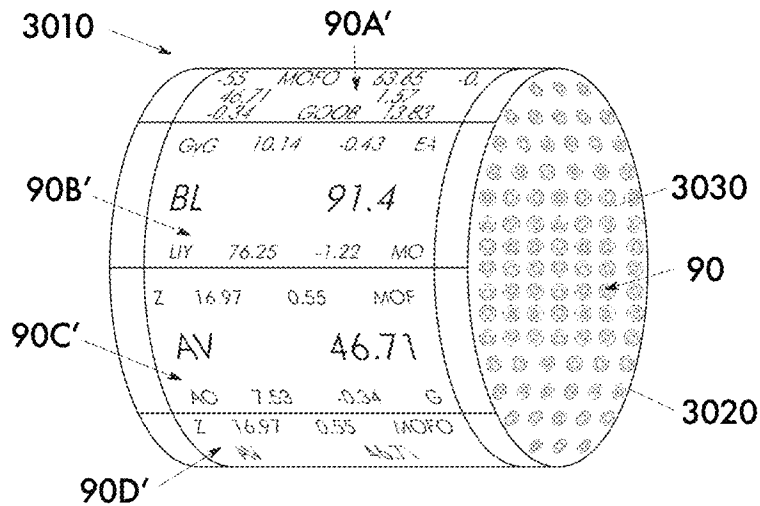

FIG. 14B

COMMUNICATION DEVICES, METHODS, AND SYSTEMS

CROSS-REFERENCE TO RELATED APPLICATIONS

This application is a § 1.53(b) continuation of prior U.S. patent application Ser. No. 18/388,489, filed Nov. 9, 2023, now U.S. Pat. No. 11,931,174, which is a continuation of U.S. patent application Ser. No. 18/143,142, filed May 4, 2023, now U.S. Pat. No. 11,864,914, which is a continuation of U.S. patent application Ser. No. 18/092,398, filed Jan. 2, 2023, now U.S. Pat. No. 11,684,313, which is a continuation of U.S. patent application Ser. No. 17/213,117, filed Mar. 25, 2021, now U.S. Pat. No. 11,589,816, which is a continuation of U.S. patent application Ser. No. 16/757,482, filed Apr. 20, 2020, now U.S. Pat. No. 10,959,674, which is a § 371 National Stage Entry of International Patent Application No. PCT/US18/56814, filed Oct. 22, 2018, claiming the benefit of priority of U.S. Provisional Patent Application No. 62/676,949, filed May 26, 2018, and U.S. Provisional Patent Application No. 62/575,951, filed Oct. 23, 2017, the entireties of which are incorporated by reference into the enclosed application.

TECHNICAL FIELD

Aspects of the present disclosure generally relate to communication devices, methods, and systems.

BACKGROUND

Computer screens have emerged as the most common means for person-to-computer communication. In 2015, for example, it was estimated that the average adult spends roughly 10 hours a day looking at a screen to consume information and/or communicate with others. The human eye was not designed for all this screen time, and numerous health problems have been associated therewith. For example, eyestrain from hours of screen time may cause instances of eye irritation, dryness, fatigue, and/or blurred vision that last for extended periods of time. These problems are increasingly common, and the near constant production of new screen-oriented devices (e.g., the next iPhone®) suggests further increases.

Alternate means for person-to-computer communications may reduce the negative effects of excessive screen time. For example, the human body includes many non-optical nerves that are capable of communicating data to the brain, such as the nerves associated with the skin. Further improvements are required to better leverage these and other communication capabilities of living tissue. Aspects of this disclosure may solve the above reference problems, solve other known problems, and/or overcome other deficiencies in the prior art.

SUMMARY

Numerous aspects are disclosed in this application. One exemplary aspect is a communication device comprising: a body comprising a distal surface compatible with skin; a tissue interface on the distal surface, the tissue interface comprising a plurality of energy generators, each energy generator being operable to output a plurality of energies in a signal direction toward the skin; an attachment element configured to maintain the tissue interface against the skin; and a processing unit configured to communicate with

nerves associated with the skin by receiving input data from a data source and causing the plurality of energy generators to output an energy signal in the signal direction with one or more energies of the plurality of energies.

5 The body may be flexible. The body may comprise a plurality of communication bays, and each energy generator may be located in and configured to output the energy signal out of one of the communication bays. The body may comprise an insulating material configured to promote flows of the one or more energies out of each communication bay in the signal direction, and limit flows of the one or more energies between the plurality of communication bays. The attachment element may comprise a plurality of holes aligned with the plurality of communication bays, and each energy generator may be configured to output the plurality of energies through one of the holes. An interior surface of each communication bay or hole may be configured to direct the one or more energies in the signal direction. The interior surface of each communication bay or hole may be configured to focus at least one energy of the one or more energies in the signal direction.

The attachment element may comprise a biocompatible adhesive disposed on the distal surface of the body. The attachment element may comprise an elastic portion configured to maintain the tissue interface against the skin. The elastic portion may expand to receive a circular portion of the skin and contract to maintain the tissue interface against the circular portion of the skin. The body may be removably attached to the attachment element. The input data may comprise a measurement, and the processing unit may be configured to modify at the energy signal based on the measurement. The processing unit may be configured determine a change of the measurement and modify the energy signal based on the change of the measurement.

35 The plurality of energy generators may be spaced apart on the distal surface of the body in a pattern; each energy generator may be operable to output the one or more energies in the signal direction toward a different point on the pattern; and the energy signal may comprise a plurality of symbols based on the pattern. Each symbol may comprise a plurality of dots, and each dot may correspond with one of the different points on the pattern. The plurality of symbols may comprise at least one alphanumeric symbol. The processing unit may be operable with the plurality of energy generators to scroll the plurality of symbols across the skin at a scroll rate in a communication direction transverse with the signal direction.

The input data may comprise vital signs of a subject, and the plurality of symbols may comprise a symbol associated with each vital sign. The plurality of symbols may comprise a symbol associated with an identity or location of the subject. The processing unit may be configured to: determine a change of the vital signs; and modify the one or both of the plurality of symbols and the scroll rate based on the change of the vital signs. The processing unit may be configured to: output one or more of the plurality of symbols with a first combination of the one or more energies when the change is within a predetermined range; and output the one or more of the plurality of symbols with a second combination of the one or more energies when the change is outside the predetermined range.

The data source may comprise one or more data sources, and the processing unit may be configured to: receive the input data from the one or more data sources; generate a control signal based on the input data; and cause the plurality of energy generators to output the energy signal according to the control signal. The processing unit may be configured to:

determine a change in the input data; and modify the control signal based on the change of the input data. The control signal may comprise a scroll rate for the energy signal the processing unit may be configured to: determine the scroll rate based on the input data; and cause the plurality of generators to scroll the energy signal across the skin at the scroll rate.

Each energy generator may comprise a plurality of generator elements and a controller operable with the plurality of generator elements to output the plurality of energies; the control signal may comprise output commands for each controller of each energy generator; and each controller may be configured to receive the control signal, select one of the output commands, and cause one or more of the plurality of generator elements to output the one or more energies based on the selected one of the output commands.

Each energy generator may comprise a plurality of generator elements, and each generator element may be operable to output one of the plurality of energies in the signal direction. The plurality of generator elements may comprise one or more of: an impact generator element; a heat generator element; a shock generator element; and a pressure generator element. Each generator element may be configured to output the one of the plurality of energies toward a similar point or area on the skin. The plurality of generator elements may be arranged coaxially with a communication axis parallel to the signal direction.

The data source may comprise a local sensor that is attached to the body and configured to output a portion of the input data. The data source may comprise at least one remote sensor that is remote from the body and configured to output a portion the input data. The processing unit may be configured to receive the input data from a server in communication with the at least one remote sensor. The at least one remote sensor may comprise a health monitoring device. The device may comprise a power generator attached to the body. The power generator may comprise a photovoltaic cell mounted to a proximal surface of the body. The one or more energies may comprise: a first energy configured to communicate the energy signal; and a second energy configured to modify a penetration depth of the first energy. The first energy may be communicable with a first portion of the nerves, and the second energy may be communicable with a second portion of the nerves.

The body may comprise an impact absorbing material; and the attachment element may comprise a garment configured to maintain a position of the impact absorbing material relative to a user body. The processing unit may be configured to determine a direction of movement for the user body and output the energy signal based on the direction of movement. The processing unit may be configured to determine a change in the direction of movement and modify the energy signal based on the change in the direction of movement. The attachment element may comprise a shoe, and the distal surface of the body may comprise an interior surface of the shoe. The input data may comprise GPS signals, the processing unit may be configured to determine a direction of movement for a user body based on the GPS signals.

The attachment element may comprise a grip, and the body may comprise an exterior surface of the grip. The grip may be integral with a weapon comprising a sight, the input data may comprise data associated with an orientation of the sight, and the energy signal may be configured to communicate a status of the weapon based on the orientation of the sight. The input data may comprise data associated with an alignment of the sight with a target, and the processing unit

may be configured to output the energy signal with a first combination of the one or more energies when the target is not aligned with the sight and a second combination of the one or more energies when the target is aligned with the sight.

The device may be implantable. The attachment element may comprise a bone plate engageable with a bone to orient the tissue interface toward an underside of the skin. The attachment element may comprise a tissue in-growth structure interactable with living tissue to maintain an orientation of the tissue interface toward an underside of the skin.

The plurality of energy generators may be arranged in bands; the attachment element may be configured to maintain each band against the skin; the input data may comprise input data for each band; and the processing unit may be configured to communicate with nerves associated with the skin by causing the plurality of energy generators in each band to output a different energy signal based on the input data for each band. The body may extend along a longitudinal axis; and the bands may be spaced apart along the longitudinal axis. The body may be configured to wrap around a limb so that the longitudinal axis of body is aligned with a longitudinal axis of the limb, and the bands wrap around the limb about the longitudinal axis. The processing unit may be operable with the plurality of energy generators to scroll each different energy signal in each band in a communication direction transverse with the signal direction. The input data for each band may comprise different vital signs, and each different energy signal may be based on one of the different vital signs.

The signal direction may comprise a first signal direction and the device may comprise an optical interface on a proximal surface of the body; the optical interface may comprise at least one display element operable to output at least one color toward eyes in a second signal direction opposite of the first signal direction; and the processing unit may be operable with the tissue interface and the optical interface to communicate simultaneously with nerves associated the skin and the eyes by outputting the energy signal with the one or more energies of the plurality of energies in the first signal direction and outputting an optical signal with the at least one color in the second signal direction.

The body may extend along a longitudinal axis, and the first and second signal directions may be transverse with the longitudinal axis. The energy signal and the optical signal may be scrolled together along or about the longitudinal axis. The processing unit may be configured to: receive the input data from the data source; generate a control signal based on the input data; cause the plurality of energy generators to output the energy signal according to the control signal; and cause the at least one display element to simultaneously output the optical signal according to the control signal. The energy signal may correspond with the optical signal.

The input data may comprise vital signs of a subject, the energy signal may comprise a plurality of symbols associated with the vital signs, and the optical signal may comprise the plurality of symbols. The processing unit may be configured to: determine a change of the vital signs; and modify the plurality of symbols based on the change of the vital signs. The device may comprise a motion sensor attached to the body, and the processing unit may be configured to selectively output the optical signal in response to the motion sensor.

Another exemplary aspect may comprise a system. For example, the system may comprise: a plurality of any communication devices described herein; and at least one

5

processor that is in communication with the plurality of communication devices and configured to: generate a corrective motion signal based on position data for the plurality of communication devices; and cause each communication device to output its energy signal based on the corrective motion signal.

The system may comprise at least one position sensor configured to determine the position data and output the position data to the at least one processor. The position data may comprise an actual location of each communication device; and the at least one processor may be configured to generate the corrective motion signal based on the actual location of each communication device and a target location of each communication device. The position data may comprise an actual spatial configuration of the plurality of communication devices; and the at least one processor may be configured to generate the corrective motion signal based on the actual spatial configuration and a target spatial arrangement for the plurality of communication devices. The at least one processor may be configured to: determine a movement direction for each communication device based on the actual and target spatial arrangements; and cause each communication device to scroll its energy signal across the skin in the movement direction.

Each communication device may be mounted to a different part of a user body; and the target spatial arrangement may comprise a physical position of the user body defined by relative positions of each different part of the user body. The physical position of the user body may comprise a pose or a stance. The at least one processor may be configured to guide the user body through a series of different positions by determining the movement direction at intervals and modifying the energy signal for each interval.

Another exemplary aspect may comprise another communication device. In keeping with above, the device may comprise: a body comprising a distal surface compatible with skin; a tissue interface on the distal surface, the tissue interface comprising a plurality of energy generators, each energy generator being operable to output a plurality of energies in a signal direction toward the skin; and a processing unit configured to communicate with nerves associated with the skin by receiving input data, and causing the plurality of energy generators to output one or more energies of the plurality of energies in the signal direction.

The body may be flexible. The device may further comprise an attachment element configured to maintain the tissue interface in a position on or adjacent the skin. The distal surface of the body may comprise a biocompatible adhesive that is adherable to the skin. The body may comprise a plurality of communication bays, and each energy generator may be located in one of the communication bays. The attachment element may comprise a plurality of holes aligned with the plurality of communication bays, and each energy generator may be configured to output the plurality of energies through one of the holes. An interior surface of each communication bay or hole may be configured to direct the one or more energies in the signal direction. The interior surface may be configured to focus the at least one energy of one or more energies. The attachment element may comprise an elastic band. The body may be removably attached to the attachment element.

Another exemplary aspect may comprise another communication device. The communication device may comprise: a body comprising a distal surface compatible with skin; a tissue interface on the distal surface, the tissue interface comprising a plurality of energy generators, each energy generator being operable to output a plurality of

6

energies in a signal direction toward the skin; an attachment element configured to maintain the tissue interface against the skin; and a processing unit configured to communicate an energy signal to nerves associated with the skin by receiving input data, and causing the plurality of energy generators to output one or more energies of the plurality of energies in the signal direction.

The plurality of energy generators may be spaced apart in a grid pattern, and each energy actuator may be operable to output the plurality of energies towards a different point on the grid pattern. The energy signal may comprise a plurality of symbols, each symbol may comprise a plurality of dots, and each dot may correspond with one of the different points on the grid pattern. The plurality of dots in each symbol may be arranged in a dot pattern within the grid pattern. The processing unit may be operable with the plurality of energy generators to scroll the plurality of symbols across the skin in a communication direction transverse with the signal direction. For example, the processing unit may be operable with the plurality of energy generators to output and scroll each symbol using a different combination of the one or more energies of the plurality of energies.

The input data may comprise a measurement, and the processing unit may be configured to communicate the energy signal by selecting the one or more energies of the plurality of energies based on the measurement. For example, the processing unit may be configured to communicate the energy signal by determining a change of the measurement and modifying the one or more energies of the plurality of energies based on the change of the measurement.

Another exemplary aspect may comprise another communication device. For example, the communication device may comprise: a body comprising a distal surface compatible with skin; a tissue interface on the distal surface, the tissue interface comprising a plurality of energy generators, each energy generator being operable to output a plurality of energies in a signal direction toward the skin; an attachment element configured to maintain the tissue interface on or adjacent the skin; and a processing unit configured to communicate an energy signal to nerves associated with the skin by: (i) receiving input data; (ii) selecting one or more energies of the plurality of energies based on the input data; and (iii) causing the plurality of energy generators to output the one or more energies in the signal direction.

The processing unit may be further configured to communicate the energy signal by: (iii) determining a change in the input data; and (iv) modifying the one or more energies based on the change. The processing unit may be further configured to communicate the energy signal by: (v) selecting a scroll rate based on the input data; and (vi) causing the plurality of generators to scroll the one or more energies across the skin at the scroll rate. The energy signal may comprise a plurality of symbols scrolled across the skin in a communication direction transverse with the signal direction. At least one symbol of the plurality of symbols may be an alphanumeric symbol.

Another exemplary aspect may comprise a communication method. The method may comprise: receiving, with a processing unit, input data for a communication device comprising a tissue interface maintainable on or adjacent skin, the tissue interface comprising a plurality of energy generators, each energy generator being operable to output a plurality of energies in a signal direction toward the skin; and operating, with the processing unit, the plurality of energy generators to communicate with nerves associated

with the skin by outputting one or more energies of the plurality of energies in the signal direction based on the input data.

The receiving step may comprise receiving the input data from one or more data sources. For example, the one or more data sources may comprise at least one of patient monitoring device, a remote server, and a sensor. The receiving step may comprise receiving the input data from the one or more data sources at regular intervals, and the operating step may comprise outputting the one or more energies based on the input data received during each regular interval. The input data may comprise a control signal, and the operating step may comprise outputting the one or more energies based on the control signal.

The method may further comprise generating, with the processing unit, a control signal based on the input data, wherein the operating step comprises outputting the one or more energies based on the control signal. Generating the control signal to may comprise associating the input data with a plurality of symbols, and the operating step may comprise communicating the plurality of symbols to the skin with the one or more energies. For example, the input data may comprise vital signs of a patient, and each symbol may be associated with one or more of the vital signs. The one or more energies may comprise a first combination of the plurality of energies followed by a second combination of the plurality of energies. The one or more energies also may comprise a first energy communicable with a first portion of the nerves, and a second energy communication with a second portion of the nerves.

Another exemplary aspect may comprise another communication method. The method may comprise: receiving, with a processing unit, input data for a communication device comprising a tissue interface maintainable on or adjacent skin, the tissue interface comprising a plurality of energy generators, each energy generator being operable to output a plurality of energies in a signal direction toward the skin; and operating, with the processing unit, the plurality of energy generators to communicate an energy signal to nerves associated with the skin by outputting one or more energies of the plurality of energies in the signal direction based on the input data.

The operating step may comprise outputting different combinations of the one or more energies, and each different combination may communicate a different portion of the energy signal. The energy signal may comprise one or more symbols, and the operating step may comprise outputting the one or more energies to communicate the one or more symbols. The operating step may comprise scrolling the one or more symbols across the skin in a communication direction transverse with the signal direction. The one or more symbols may comprise an alphanumeric symbol.

The operating step may comprise: outputting a first combination of the one or more energies to communicate a first symbol of the one or more symbols, and outputting a second combination of the one or more energies to communicate a second symbol of the one or more symbols. The operating step may comprise: outputting a first combination of the one or more energies to communicate the energy signal, and outputting a second combination of the one or more energies to communicate a characteristic of the energy signal. The input data may comprise a measurement, and the operating step may comprise outputting the one or more energies based on the measurement. For example, the operating step may comprise modifying the one or more energies based on a change of the measurement.

Another exemplary aspect may comprise another communication method. For example, the method may comprise: receiving, with a processing unit, input data for a communication device comprising a tissue interface maintainable on or adjacent skin, the tissue interface comprising a plurality of energy generators, each energy generator being operable to output a plurality of energies in a signal direction toward the skin; generating, with the processing unit, a control signal based on the input data; and operating, with the processing unit, the plurality of energy generators to communicate with to nerves associated with the skin by outputting one or more energies of the plurality of energies in the signal direction based on the control signal.

Another exemplary aspect may comprise another communication device. The device may comprise: a body comprising a distal surface compatible with skin; a tissue interface on the distal surface, the tissue interface comprising a plurality of energy generators arranged in bands, each energy generator being operable to output a plurality of energies in a signal direction toward the skin; and a processing unit configured to communicate with nerves associated with the skin by receiving input data, and causing the plurality of energy generators in each band to output one or more energies of the plurality of energies in the signal direction.

The body may be flexible. The device may further comprise an attachment element configured to maintain the tissue interface in a position on or adjacent the skin. For example, the attachment element may comprise a distal surface adherable to the skin. The attachment element may be proximal of the tissue interface and configured to maintain the bands against the skin. The attachment element may be configured to maintain the bands against the skin by applying a tensile force to the body.

Another exemplary aspect may comprise another communication device. The device may comprise: a body extending along a longitudinal axis, and comprising a distal surface compatible with skin; a tissue interface on the distal surface, the tissue interface comprising a plurality of energy generators arranged in bands spaced apart along the longitudinal axis, each energy generator being operable to output a plurality of energies in a signal direction toward the skin; an attachment element configured to maintain the bands of the tissue interface against the skin; and a processing unit configured to communicate energy signals to nerves associated with the skin by receiving input data, and causing the plurality of energy generators to output an energy signal in each band with one or more energies of the plurality of energies.

The body may be configured to wrap around a limb so that the longitudinal axis of body is aligned with a longitudinal axis of the limb, and the bands wrap around the limb about the longitudinal axis. The processing unit may be configured to move the energy signal in each band so as to scroll the energy signal around the limb. The one or more energies may comprise: a first energy configured to communicate one or more symbols; and a second energy configured to modify the one or more symbols.

Another exemplary aspect may comprise another communication method. The method may comprise: receiving, with a processing unit, input data for a communication device comprising a tissue interface maintainable on or adjacent skin, the tissue interface comprising a plurality of energy generators arranged in bands, each energy generator being operable to output a plurality of energies in a signal direction toward the skin; and causing, with the processing unit, the plurality of energy generators in each band to

communicate with nerves associated with the skin by outputting one or more energies of the plurality of energies in response to the input data.

The receiving step may comprise receiving the input data from one or more data sources. For example, the receiving step may comprise: receiving input data comprise a plurality of measurements; and causing the plurality of energy generators in each band to output the one or more energies based on one measurement of the plurality of measurements. The method may further comprise outputting a first combination of the one or more energies when the one measurement is inside of an acceptable range; and outputting a second combination of the one or more energies when the one measurement is outside of the acceptable range.

The receiving step may comprise receiving input data comprising a plurality of vital signs; and the causing step may comprise causing the plurality of energy generators in each band to output the one or more energies based on one vital sign of the plurality of vital signs. The input data may comprise a control signal for each band, and the operating step may comprise outputting the one or more energies based on the control signal for each band. The method may further comprise generating, with the processing unit, a control signal for each band based on the input data, wherein the operating step may comprise outputting the one or more energies based on the control signal for each band.

Another exemplary aspect may comprise another communication method. The method may comprise: receiving, with a processing unit, input data for a communication device comprising a tissue interface maintainable on or adjacent skin, the tissue interface comprising a plurality of energy generators arranged in bands, each energy generator being operable to output a plurality of energies in a signal direction toward the skin; and causing, with the processing unit, the plurality of energy generators to communicate energy signals to nerves associated with the skin by outputting an energy signal in each band with one or more energies of the plurality of energies. The energy signal may comprise one or more symbols based on the input data, and the operating step may comprise outputting the one or more symbols to the skin with one or more energies. The operating step may comprise scrolling the one or more symbols across the skin in a communication direction transverse with the signal direction.

Another exemplary aspect may comprise a communication system. The system may comprise: (A) a plurality of communication devices, each communication device comprising: a body comprising a distal surface compatible with skin; and a tissue interface on the distal surface, the tissue interface comprising a plurality of energy generators, each energy generator being operable to output a plurality of energies in a signal direction toward the skin; and (B) a processing unit in communication with at least one of the plurality of communication devices and configured to: generate, with one or more processors, a corrective motion signal based on position data for the plurality of communication devices; and operate, with the one or more processors, the plurality of energy generators of each communication device to output one or more energies of the plurality of energies in the signal direction based on the corrective motion signal.

The system may further comprise at least one position sensor configured to determine the position data and output the position data to the processing unit. The position data may comprise an actual location of each device of the plurality of communication devices; and the processing unit may be configured to generate, with the one or more

processors, the corrective motion signal based on the actual locations and a target location for each device of the plurality of communication devices.

The position data may comprise an actual spatial arrangement of the plurality of communication devices; and the processing unit may be configured to generate, with the one or more processors, the corrective motion signal based on the actual spatial arrangement and a target spatial arrangement for the plurality of communication devices. The processing unit may be configured to: determine, with the one or more processors, a movement direction for each communication device based on the actual and target spatial arrangements; and operate, with the one or more processors, the plurality of energy generators of each communication device to output the one or more energies toward the skin in the signal direction and move the one or more energies across the skin the movement direction.

Another exemplary aspect may comprise another communication method. The method may comprise: generating, with one or more processors, a corrective motion signal for a plurality of communication devices based on position data, each communication device comprising a tissue interface with a plurality of energy generators, each energy generator being operable to output a plurality of energies in a signal direction toward the skin; and operating, with the one or more processors, the plurality of energy generators of each communication device to output one or more energies of the plurality of energies in the signal direction based on the corrective motion signal. The method may comprise receiving the position data from the plurality of communication devices or a remote position sensor.

Another exemplary aspect may comprise another communication method. The method may comprise: receiving, with one or more processors, position data for a plurality of communication devices mountable on or adjacent skin, each device comprising a tissue interface with a plurality of energy generators, each energy generator being operable to output a plurality of energies in a signal direction toward the skin; receiving or generating, with the one or more processors, a corrective motion signal for the plurality of communication devices based on position data for each communication device; and operating, with the one or more processors, the plurality of energy generators of each communication device to output one or more energies of the plurality of energies in the signal direction based on the corrective motion signal.

At least one of the communication devices may comprise a position sensor, and the method may comprise receiving, with the one or more processors, the position data from the position sensor. The method may comprise: determining, with the one or more processors, an actual spatial arrangement of the plurality of communication devices based on the position data; and identifying, with the one or more processors, a target spatial arrangement for the plurality of communication devices, wherein the generating step comprises generating, with the one or more processors, the corrective motion signal based on the actual spatial arrangement and the target spatial arrangement. The method may comprise: determining, with the one or more processors, a movement direction for each communication device based on actual and target spatial arrangements; and operating, with the one or more processors, the plurality of energy generators of each communication device to output one or more energies toward the skin in a shape associated with the movement direction for each communication device.

The method may comprise operating, with the one or more processors, the plurality of energy generators of each

11

communication device to move the shape across the skin in the movement direction. Each communication device may be mounted to a different portion of a body; and the target spatial arrangement may comprise a physical position of the body defined by the relative positions of each different portion of the body. The physical position of the body may comprise at least one of a stretching position, a lifting position, a pose, or a stance.

The target spatial arrangement may comprise a series of target spatial arrangements, and the method may comprise: selecting arrangements from the series of target spatial arrangements; and repeating the determining, generating, and operating steps for each selected arrangement. The selecting step may be performed at predetermined intervals so as to coordinate relative movements between each selected arrangement. The series of target spatial arrangements may comprise one or more stretches, yoga poses, or defensive postures.

Another exemplary aspect may comprise another communication device. The device may comprise: a body comprising a proximal surface compatible with eyes, and a distal surface compatible with skin; a tissue interface on the distal surface, the tissue interface comprising a plurality of energy generators, each energy generator comprising a tissue interface operable to output a plurality of energies in a first signal direction toward the skin; an optical interface on the proximal surface, the optical interface comprising at least one display element operable to output at least one color in a second signal direction toward the eyes; and a processing unit operable with the tissue interface and the optical interface to communicate simultaneously with nerves associated with skin and eyes by outputting one or more energies of the plurality of energies in the first signal direction and at least one color in the second signal direction.

The body may extend along a longitudinal axis, and the first signal direction may be transverse with the longitudinal axis. The second signal direction may be transverse with the longitudinal axis. The first and second signal directions may extend oppositely along a signal axis transverse with the longitudinal axis. The body may be conformable with a curved shape. The body comprises a flexible body configured to wrap around a limb so that the longitudinal axis has a circular shape.

The processing unit may receive input data from one or more sources, the one or more energies may be output as an energy signal based on the input data, and the one or more colors may be simultaneously output as an optical signal based on the input data. The energy signal may correspond with the optical signal. The outputs may be flashed or scrolled together. For example, the optical signal and the energy signal may be scrolled together along the longitudinal axis. The input data may comprise a vital sign of the patient, the energy signal may communicate the vital sign to the skin, and the optical signal may simultaneously communicate the vital sign to the eyes. The processing unit may be configured to determine a change of the vital sign over time and simultaneously modify one or both of the optical signal and the energy signal based on the change. The input data may comprise alphanumeric symbols, the optical signal may communicate the alphanumeric symbols to the eyes, and the energy signal may simultaneously communicate the symbols to skin.

Another exemplary aspect may comprise another communication device. The device may comprise: a body extending along a longitudinal axis, the body comprising a proximal surface compatible with eyes and a distal surface compatible with skin; a tissue interface on the distal surface

12

of the body, the tissue interface comprising a plurality of energy generators, each energy generator being operable to output a plurality of energies in a first signal direction toward the skin; an optical interface on the proximal surface, the optical interface comprising at least one display element operable to output at least one color in a second signal direction toward the eyes; a sensor on the body; and a processing unit configured to communicate simultaneously with nerves associated with the eyes and the skin by: receiving input data from the sensor or a remote data source, causing the plurality of energy generators to output one or more energies of the plurality of energies in the first signal direction as an energy signal, and causing the display element to output the at least one color in the second signal direction as an optical signal.

The first and second communication signals may be scrolled together along the longitudinal axis. The energy signal may be output continuously. The optical signal may be output in response to a movement detected by the sensor. The movement may comprise aligning the optical interface with the eyes.

Another exemplary aspect may comprise another communication device. The device may comprise: a body comprising a proximal surface compatible with eyes and a distal surface compatible with skin; a tissue interface on the distal surface of the body, the tissue interface comprising a plurality of energy generators, each energy generator being operable to output a plurality of energies in a first signal direction toward the skin; at least one sensor; an optical interface on the proximal surface, the optical interface comprising at least one display element operable to output at least one color in a second signal direction toward the eyes; a processing unit configured to communicate simultaneously with nerves associated with the eyes and the skin by: receiving vital sign data from the at least one sensor, causing the plurality of energy generators to output one or more energies of the plurality of energies in the first signal direction as an energy signal, and causing the at least one display element to output the at least one color in the second signal direction as an optical signal.

The energy signal and the optical signal may be scrolled across the body in a communication direction transverse with the longitudinal axis. The at least one display element may comprise a touchscreen, and the energy signal may be moveable together with optical signal along or around the longitudinal axis by operation of the touchscreen. The first direction may be transverse with the second direction.

BRIEF DESCRIPTION OF THE DRAWINGS

The accompanying drawings are incorporated in and constitute a part of this specification. These drawings illustrate exemplary aspects of the present disclosure that, together with the written descriptions provided herein, serve to explain the principles of this disclosure.

FIG. 1A depicts an exemplary energy signal output onto a living tissue;

FIG. 1B depicts an exemplary communication device configured to output the energy signal of FIG. 1A;

FIG. 2A depicts a top-down view of the FIG. 1B device; FIG. 2B depicts a bottom-up view of the FIG. 1B device; FIG. 2C depicts a cross-section view of the FIG. 1B device taking along section line A-A of FIG. 2A;

FIG. 3A depicts a cross-section of an exemplary energy generator;

FIG. 3B depicts a bottom-up view of the FIG. 3A generator;

FIG. 4A depicts an impact energy output with the FIG. 3A generator;
 FIG. 4B depicts a heat energy output with the FIG. 3A generator;
 FIG. 4C depicts an electrical energy output with the FIG. 3A generator;
 FIG. 4D depicts a pressure energy output with the FIG. 3A generator;
 FIG. 5 depicts an exemplary processing unit;
 FIG. 6A depicts another exemplary communication device;
 FIG. 6B depicts another exemplary communication device;
 FIG. 6C depicts another exemplary communication device;
 FIG. 6D depicts another exemplary communication device;
 FIG. 7A depicts another exemplary communication device;
 FIG. 7B depicts another exemplary communication device;
 FIG. 7C depicts another exemplary communication device;
 FIG. 7D depicts another exemplary communication device;
 FIG. 8A depicts another exemplary communication device;
 FIG. 8B depicts a cross-section view of the FIG. 8A device;
 FIG. 9 depicts an exemplary method;
 FIG. 10 depicts another exemplary method;
 FIG. 11 depicts an exemplary communication system;
 FIG. 12 depicts another exemplary method;
 FIG. 13A depicts another exemplary communication device;
 FIG. 13B depicts another view of the device of FIG. 13A;
 FIG. 14A depicts another view of the device of FIG. 13A;
 and
 FIG. 14B depicts another view of the device of FIG. 13A.

DETAILED DESCRIPTION

Aspects of the present disclosure are now described with reference to exemplary communication devices, methods, and systems. Particular aspects reference a healthcare setting, wherein the described devices, methods, and systems may allow a single caregiver to monitor vital signals for a plurality of patients without using a screen, or at least with a reduced amount of screen time. Any references to a particular setting, such as healthcare; a particular user, such as a caregiver; a particular data, such as vital signals; or particular amount of screen time, are provided for convenience and not intended to limit the present disclosure unless claimed. Accordingly, the aspects disclosed herein may be utilized for any analogous communication device, method, or system—healthcare-related or otherwise.

The terms “proximal” and “distal,” and their respective initials “P” and “D,” may be used to describe relative components and features. Proximal may refer to a position closer to a hand of user, whereas distal may refer to a position further away from said hand. With respect to a hand adjacent a living tissue, for example, proximal may refer to a position away from the tissue, whereas distal may refer to a position toward said tissue. As a further example, with respect to energy directed toward the living tissue, proximal may refer to energy directed away from the tissue and distal may refer to energy directed toward the tissue. Appending

the initials P or D to a number may signify its proximal or distal location or direction. Unless claimed, these directional terms are provided for convenience and not intended to limit this disclosure.

Aspects of this disclosure may be described with reference to one or more axes. For example, an element may extend along an axis, be moved along said axis in first or second direction, and/or be rotated about said axis in a first or second direction. One axis may intersect another axis, resulting in a transverse and/or perpendicular relationship therebetween. For example, two or three perpendicular axes may intersect at an origin point to define a Cartesian coordinate system. The directional terms proximal and distal may be used with reference to any axis. One axis may be a longitudinal axis extending along a length of an element, such as a central longitudinal axis extending along the length and through a centroid of the element.

Terms such as “may,” “can,” and like variation, are intended to describe optional aspects of the present disclosure, any of which may be covered by the claims set forth below. Terms such as “comprises,” “comprising,” or like variation, are intended to describe a non-exclusive inclusion, such that a device, method, or system comprising a list of elements does not include only those elements, but may include other elements not expressly listed or inherent thereto. The term “and/or” indicates a potential combination, such that a first and/or second element may likewise be described as a first element, a second element, or a combination of the first and second elements. These potential combinations are provided as examples. Numerous other combinations are inherent to this disclosure. Unless stated otherwise, the term “exemplary” is used in the sense of “example” rather than “ideal.”

Aspects of this disclosure are directed to devices, methods, and systems for communicating with the brain through nerves associated with a living tissue. Some aspects are described with reference to an energy signal including one or more energies output to communicate symbols to the living tissue. The symbols may be used to communicate data, and the one or more energies may be used to communicate aspects of the data. The living tissue may be a portion of skin, as shown in FIGS. 1A-8D. In a healthcare setting, the energy signal may be output towards the skin of a caregiver to communicate symbols associated with a status of a patient. For example, an intensity of the one or more energies may escalate responsive to a measure of the status, providing a non-visual alert to the caregiver if the measure changes.

Exemplary energies and energy signals are now described with reference to FIG. 1A, which depicts an exemplary energy signal 90 including a plurality of symbols 92 output onto a communication area 4 of a skin 2 with one or more energies 32. For illustrative purposes, the symbols 92 of FIG. 1 are shown from a proximal-to-distal direction, as they would be output to skin 2 by an energy transceiver. Each energy 32 may be configured to communicate aspects of the data to the brain through nerves associated with skin 2, such as nerves located distal of communication area 4. For example, the one or more energies 32 shown in FIG. 1A may be recognizable by touch receptors, such as the Meissner’s corpuscle; temperature receptors, such the Ruffini corpuscle and Krause corpuscle; electrical receptors, such as the muscles and pain receptors located in the dermis layer; pressure receptors such as the Pacinian corpuscle; and/or other cutaneous or subcutaneous nerves that innervate the skin or other living tissue.

15

Each symbol **92** may be associated with different data. For example, in the healthcare setting, each symbol **92** may be associated with a vital sign of the patient, such as body temperature, pulse rate, respiration rate, and/or blood pressure. As shown in FIG. 1A, the plurality of symbols **92** may include a first symbol **92A**, a second symbol **92B**, and a third symbol **92C**. In keeping with the previous example, first symbol **92A** may be associated with temperature and pulse rate, second symbol **92B** may be associated with respiration rate, and third symbol **92C** may be associated with blood pressure. Any number of symbols **92** may be provided and/or associated with a measurable or non-measurable characteristic of the patient.

Symbols **92A**, **92B**, and **92C** are shown as pip patterns of dots in FIG. 1A, wherein each dot is a shaded area. Each dot may represent an output of the one or more energies **32**. Aspects of energies **32** and/or each symbol **92A**, **92B**, and **92C** may increase the complexity of energy signal **90**, and thus the amount of data transmitted therewith. As shown in FIG. 1A, symbols **92A**, **92B**, and **92C** may be scrolled across communication area **4** by outputting energies **32** toward the skin in the pip patterns; and moving the patterns across the skin in a communication direction CD. In FIG. 1A, first symbol **92A** is a pip five dot pattern; second symbol **92B** is a pip six dot pattern; and a third symbol **92C** is a pip three dot pattern that has been truncated by an end of communication area **4** due to the scrolling. Symbols **92** may be flashed and scrolled. For example, the five dots of first symbol **92A** in FIG. 1A may be output to communicate a temperature range of the patient (e.g., a normal range), and flashed on-and-off to communicate the pulse rate of the patient.

An exemplary energy transceiver **10** is depicted in FIG. 1B as being configured output energy signal **90** to communication area **4** of skin **2**. As shown, energy transceiver **10** may be attached to a portion of skin **2**, including any portion located on a limb, such as the underside of a human wrist shown in FIG. 1B for example. Communication area **4** may be sized approximate to a perimeter of transceiver **10**. In this configuration, transceiver **10** may be configured to communicate energy signal **90** to skin **2** by outputting the one or more energies **32** toward communication area **4** in a signal direction oriented toward skin **2**. As shown in FIG. 1A, the energies **32** may be output individually and/or in combination to communicate aspects of any of symbols **92A**, **92B**, and **92C** to skin **2**.

Additional aspects of exemplary energy transceiver **10** are now described with reference to FIGS. 2A-C. As shown, transceiver **10** may comprise: a body **20**; a tissue interface **30**; a processing unit **60**; and an attachment element **70**. With these elements, and the variations described herein, energy transceiver **10** may be configured to communicate energy signal **90** to nerves associated with skin **2** by outputting the one or more energies **32** towards skin **2** with tissue interface **30**.

As shown in FIGS. 2A-C, body **20** may contain the elements of energy transceiver **10**. For example, body **20** of FIGS. 2A-C has a length extending along a longitudinal axis X-X, a width extending along a lateral axis Y-Y, and a thickness extending along a proximal-distal axis Z-Z. The length, width, and/or thickness of body **20** may be compatible with skin **2**. For example, body **20** may be composed of a flexible biocompatible base material, such as a polymeric material, so that the length and width of body **20** are conformable against a curvature of skin **2**.

Body **20** may include any shape and be conformable with any curvature. For example, body **20** may be conformable with a cylindrical shape of a human forearm (e.g., FIG. 1B),

16

a semi-spherical shape a human forehead (e.g., FIG. 6B), or an irregular curved shape of a human foot (e.g., FIG. 7A). A plurality of bodies **20** may be joined together to accommodate some curvatures. For example, side surfaces of body **20** of FIGS. 2A-C may be removable engageable with side surfaces of additional bodies **20** to create a joined layer conformable with the curvature.

The base material of body **20** may have insulating and/or energy-directing properties. For example, the base material may include compositions and/or coatings that promote energy flows along proximal-distal axis Z-Z, and limit energy flows along axes X-X and/or Y-Y. Body **20** may be manufactured from the base material using any known process. For example, body **20** may be molded or 3D printed from a base material that is biocompatible, dielectric, impact resistance, sound absorbing, and/or thermally resistant, such as polyether ether ketone (PEEK) and like polymeric materials. Additional materials and/or coatings may be included with the base material and/or applied to body **20** to further promote biocompatibility.

As shown in FIGS. 2A-C, body **20** may define a proximal surface **22** (FIG. 2A) opposite of a distal surface **24** (FIG. 2B) along proximal-distal axis Z-Z (FIG. 2C). In FIGS. 2A and 2C, for example, proximal surface **22** includes a processor compartment **23** configured to receive processing unit **60**. As shown, and described further below, processing unit **60** may be removable engageable (e.g., snap-fit into) with processor compartment **23**. Body **20** may include and/or be compatible with additional mechanisms for securing and/or releasing the snap-fit, such as a retaining screw and/or a lever.

Body **20** of FIGS. 2A-C includes a plurality of communication bays **25**. As shown, each communication bay **25** may be spaced apart from the next on distal surface **24** in a grid pattern. The spacing may be uniform or non-uniform. In FIGS. 2B and 2C, the bays **25** are spaced apart uniformly for communication with the skin **2** of FIG. 1B, which has a fairly planar surface area. Non-uniform spacing may be used to accommodate a curvature of skin **2**. As shown in FIG. 2C, each communication bay **25** may extend proximally into body **20** through distal surface **24** along a communication axis z-z that is parallel with the proximal-distal axis Z-Z of transceiver **10**. In FIG. 2C, a conduit **26** extends proximally from each bay **25**, through an interior portion of body **20**, and into processor compartment **23**, placing the plurality of bays **25** in communication with compartment **23**.

Aspects of tissue interface **30** are now described with reference to FIGS. 2B and 2C. As shown, tissue interface **30** may include a plurality of energy generators **31**, and each generator **31** may be located in one of communication bays **25**. Each generator **31** may be operable with processing unit **60** to output energies **32** individually and/or in combination. In FIGS. 2B and 2C, for example, the one or more energies **32** are being output from the shaded generators **31** to communicate energy signal **90** of FIG. 1A. As shown in FIG. 2C, one or more conductors **27** may extend through each conduit **26** to connect processing unit **60** to each energy generator **31**, allowing control signals to be transmitted between processing unit **60** and the plurality of energy generators **31** along one or more pathways.

As shown in FIG. 2C, the one or more conductors **27** may include any number of electrical wires and/or optical fibers configured to transmit the control signals. For example, the conductors **27** may comprise a plurality of electrical conductors interconnecting the plurality of generators **31** with processing unit **60**, and allowing electricity-based control signals, energies, and communications to be transmitted

17

between unit 60 and generators 31. In addition or alternatively, the conductors 27 may comprise a plurality of optical fibers interconnecting the plurality of generators with processing unit 60, and allowing light-based control signals, energies, and communications to be transmitted between unit 60 and generators 31. For example, each conductor 27 may comprise a twisted pair including at least one electrical conductor and at least one optical fiber. A flexible energy-insulating medium, such as an epoxy, may be used to seal conductors 27 in conduits 26.

A cross-section of an exemplary energy generator 31 is depicted in FIG. 3A. As shown, each generator 31 may include: a housing 33; a controller 34; and a plurality of generator elements, such as: an impact generator element 36; a heat generator element 42; a shock generator element 48; and a pressure generator element 52. Examples of each generator element are now described.

Similar to body 20, housing 33 may include an insulating material that surrounds portions of each generator 31 and/or defines mounting surfaces for generator elements 36, 42, 48, and/or 52. For example, housing 33 may be made of the same base material as body 20 or a compatible material; and/or formed together with body 20 by a molding, printing, or like process. As described below, portions of each generator element 36, 42, 48, and/or 52 may extend distally from housing 33 to contact skin 2. Housing 33 of FIG. 3A includes an attachment feature 33A configured to secure each generator 31 in one of the communication bays 25. For example, attachment feature 33A may include a set of threads on housing 33 that are engageable with an interior surface of bays 25. Other types of chemical or mechanical attachment may be used, including biocompatible adhesives, snap-fit connections, and the like.

Exemplary generator elements 36, 42, 48, and 52 may be arranged to output their respective energies 32 in approximately the same direction. As shown in FIGS. 3A and 3B, each generator element 36, 42, 48, and 52 may be arranged coaxially with communication axis z-z so that each energy 32 may be output toward skin 2 in signal direction SD. Because of this coaxial configuration, each energy 32 may be output toward approximately the same point or area on skin 2, making the energies 32 interchangeable. For example, any of the dots included in energy signal 90 of FIG. 1A may be interchangeably communicated to approximately the same point on skin 2 with any of the energies 32.

As shown in FIG. 3A, controller 34 may be configured to receive a control signal 82 from processing unit 60, and activate generator elements 36, 42, 48, and 52 according to signal 82. The one or more conductors 27 may transmit the control signal 82 to generator elements 36, 42, 48, and 52 from processing unit 60 and/or direct electricity to generator elements 36, 42, 48, and 52 from a power source 66 of processing unit 60 (e.g., FIG. 5). Energy transceiver 10 may be an all-electrical device, wherein control signal 82 is an electrical signal and first and the conductors 27 are electrical wires. For varied response times, and energy requirements, transceiver 10 also may be an electro-optical device, wherein control signal 82 includes an optical signal, and at least one of the conductors 27 includes an optical fiber. For example, controller 34 may receive control signal 82 from processing unit 60 with a first one of conductors 27 (e.g., a first electrical and/or optical conductor), and direct electricity to one or more of the generator elements 36, 42, 48, and 52 with a second one of conductors 27 (e.g., a second electrical conductor) according to signal 82.

Additional aspects of generator elements 36, 42, 48, and 52 are now described with reference to FIGS. 4A-D. As

18

shown in FIG. 4A, for example, impact generator element 36 may be configured to communicate an impact energy 32A to the brain through nerves associated with skin 2. For example, impact generator element 36 may be a mechanical actuator that converts electricity from power source 66 into a mechanical movement recognizable by touch receptors of skin 2, such as Meissner's corpuscle. As shown, generator element 36 may include a drive mechanism 37, a piston 38, a tissue contact 39, and a guide tube 40. Drive mechanism 37 may include a motor assembly that is attached to controller 34 and conductively engaged therewith. In this configuration, controller 34 may direct electricity to drive mechanism 37, causing the motor assembly to move piston 38 distally along communication axis z-z, outputting impact energy 32A in signal direction SD. Different force transfer components also may be used to apply energy 32A, including levers and like actuators.

As shown, drive mechanism 37 may be configured to move piston 38 between a retracted position, wherein tissue contact 39 is contained housing 33 (e.g., FIG. 3A); and an extended position, wherein at least a portion of contact 39 is distal of housing 33 (e.g., FIG. 4A). Accordingly, impact energy 32A may be output in signal direction SD as a physical movement of skin 2 caused by moving tissue contact 39 distally. Aspects of impact energy 32A may be modified. For example, outer tube 40 may be attached to housing 33 and include interior surfaces configured to modify the timing of energy 32A by guiding the proximal-distal movements of tissue contact 39 (e.g., by rotating or stabilizing contact 39). A resilient element may be added between drive mechanism 37 and contact 39 to dampen such movements.

Heat generator element 42 may be configured to communicate a heat energy 32B to the brain through nerves associated with skin 2. As shown in FIG. 4B, generator element 42 may include an electrical resistor that converts electricity from power source 66 into an amount of heat recognizable by temperature receptors of skin 2, such as the Ruffini corpuscle. For example, heat generator element 42 may include an electrical resistor 43, a heat reflecting groove 44, a conductor 45, and an insulating material 46. Groove 44 may include a metal plate attached to an exterior surface of outer tube 40 of generator element 36. Resistor 43 may include an electrical wire or coil attached to groove 44. Conductor 45 may include an electrical wire extend between controller 34 and resistor 43, and material 46 may include an epoxy surrounding conductor 45.

As shown in FIG. 3B, electrical resistor 43 and heat-reflecting groove 44 may be circular elements arranged coaxially with communication axis z-z. Conductor 45 may be configured to transmit electricity to electric resistor 43 for conversion into heat energy 32B. Groove 44 may include a concave shape extending proximally into housing 33 to contain resistor 43, and the shape may include a distal surface configured to reflect heat energy 32B toward skin 2. In this configuration, heat signal 32B may be output in signal direction SD as an amount of heat transferred to skin 2 by resistor 43. Aspects of heat signal 32B may be modified. For example, the size, shape, and/or exterior coating of resistor 43 or groove 44 may be configured to modify the intensity of heat energy 32B.

Shock generator element 48 may be configured to communicate an electrical energy 32C to the brain through nerves associated with skin 2. As shown in FIG. 4C, shock generator element 48 may be an electroshock generator that converts electricity from power source 66 into an electrical shock recognizable by electricity-sensitive receptors, such

as the muscles and pain receptors located in the dermis layer of skin 2. For example, energy generator element 48 may include at least two electric contacts 49, a conductor 50, and an insulating material 51. The conductors 50 may be metallic rods or wires extending distally from controller 34. Insulating material 51 may be an epoxy surrounding each conductor 50. Each contact 49 may include a discharge shape located on the distal-most end of one of conductors 50. In this configuration, controller 34 may direct electricity through conductors 50, and into the discharge shape of contact 49, allowing electricity to flow through skin 2 between the contacts 49 to output electrical energy 32C.

As shown in FIG. 3B, the electrical contacts 49 may be spaced apart in a radial pattern coaxial with communication axis z-z. Any number of contacts 49 may be used, in any geometrical and/or spatial configuration. Insulating material 51 may be used to define and maintain the spacing. As shown, insulating materials 51 and 46 may be the same material, such as an epoxy. Four contacts 49 are shown in FIG. 3B, for example, as being arranged in two pairs. Aspects of electrical energy 32C may be modified. For example, the arrangement of contacts 49 may be changed; and/or the size of or spacing between each contact 49 changed to modify the intensity of energy 32C.

Pressure generator element 52 may be configured to communicate a pressure energy 32D to the brain through nerves associated with skin 2. As shown in FIG. 4D, pressure generator element 52 may be an electroacoustic transducer that converts electricity from power source 66 into a sound wave recognizable by pressure receptors of skin 2, such as the Pacinian corpuscle. For example, pressure generator element 52 may include a cone 53, a voice coil 54, and a magnet 55. In this configuration, controller 34 may direct electricity into voice coil 54 for interaction with magnet 55, causing movements of cone 53 that generate the pressure energy 32D in signal direction SD.

As shown in FIGS. 3B and 4D, cone 53 may have a frustoconical shape that is coaxial with communication axis z-z. An outer edge of cone 53 may be attached an interior surface of housing 33, and an inner edge of cone 53 may be attached to voice coil 54, which may be coupled to controller 34 and power source 66 by one or more conductors. As shown, coil 54 may have a circular shape, and generator elements 36, 42, and 48 may be located in the interior of said shape. Aspects of pressure energy 32D may be modified. For example, cone 53 and/or voice coil 54 may include a surround, a spider, a secondary frame, or any other structures configured to modify signal responsiveness; the strength of magnet 55 may be varied; and/or controller 34 may include an amplifier configured to modify an intensity of pressure energy 32D.

Different generator element types also may be used to communicate signals to the skin with different energies 32, and/or different combinations of energies 32. For example, the plurality of generators 31 may be modified to vary individual or combined outputs of energies 32A, 32B, 32C, and 32D; and/or include additional generator elements configured to output additional signals to skin 2, including optical signals, magnetic signals, and/or any physically recognizable signals. Any type of generator element may be used and likewise coaxially arranged according to FIGS. 3A through 4D.

Additional aspects of an exemplary processing unit 60 are now described with reference to FIG. 5. As shown, processing unit 60 may be configured to receive input data 80 from a data source 81 and output control signal 82 and/or electricity to each controller 34 via conductors 27, causing

activation of one or more energy generators 31. For example, processing unit 60 of FIG. 5 includes a housing 61, a data transceiver 62, one or more processors 63, a memory 64, a communication bus 65, and a power source 66.

Data source 81 may include any combination of local and/or remote data sources. For example, source 81 may include a local sensor that is located in one of communication bays 25 and configured to send input data 80 to unit 60 using conductors 27 and/or bus 65. This configuration may allow for closed loop communications in which energy signal 90 is based on data from the local sensors. For example, the local sensor may generate the input data 80 based on chemical and/or physical outputs related to skin 2.

Data source 81 also may include a remote data source in constant communication with processing unit 60 via data transceiver 62, such as a remote sensor configured to send input data 80 to processing unit 60 with data transceiver 62 over a wired or wireless connection. This configuration may allow for open loop communications in which energy signal 90 is based on data from the local sensor and/or the remote sensor.

Any number and type of local sensors may be used to generate input data 80, and the sensor(s) may be located at any position on or relative to energy transceiver 10. In the healthcare setting, for example, one local sensor may include a personal health tracker (e.g., a Fitbit® or an iWatch®) configured to generate input data 80 based on chemical and/or physical outputs of the wearer (e.g., heart rate, temperature), and communicate input data 80 to data transceiver 62 at regular intervals (e.g., once per second or once per minute).

Housing 61 may contain the elements of processing unit 60, and/or provide a means for removing processing unit 60 from body 2, allowing for easy repairs and upgrades. As shown in FIGS. 1B and 5, for example, exterior surfaces of housing 61 may be snap-fit with interior surfaces of compartment 23 so that the distal surface of processing unit 60 is maintained against the proximal surface of compartment 23. For example, the exterior surfaces of housing 61 of may include protrusions biased outwardly along the X-X and Y-Y axes, and the interior surfaces of compartment 23 may include grooves configured to receive said protrusions.

Transceiver 62 may include any wired or wireless communication technology configured to receive input data 80 from any data source(s) 81, such as Bluetooth, Wi-Fi 33, and the like. As shown in FIG. 5, input data 80 may be generated with or stored on data source 81 and received with transceiver 62. In a healthcare setting, for example, data source 81 may include at least one patient monitoring device configured to send input data 80 to a remote server at regular intervals (e.g., once per minute). Data 80 may include various measures regarding the patient, such as body temperature, pulse rate, respiration rate, and/or blood pressure. For example, transceiver 62 may be configured to retrieve and/or receive data 80 from the remote server at regular intervals (e.g., once per second or once per minute).

Each control signal 82 may be received with input data 80. Data transceiver 62 may be configured to relay the signals 82 to the one or more processors 63 and/or memory 64. Alternatively, processing unit 60 may be configured to generate each control signal 82 based on input data 80. For example, memory 64 may include a signal generating program, and the one more processors 63 may be configured to generate each control signal 82 with the program. In keeping with previous examples, the signal generating program may be configured to: analyze the input data 80 sent from data sources 81 including a patient monitoring device during an

21

interval; generate symbol 92A from the temperature and pulse rate, symbol 92B from the respiration rate, and symbol 92C from the blood pressure; and output a control signal 82 for communicating the symbols 92A, 92B, and 92C to skin 2.

As shown in FIG. 5, communication bus 65 may be configured to connect the one or more processors 63 and memory 64 to each generator 31, such as to each controller 34. Bus 65 may include electrical and/or optical connectors 67 located on and/or extending distally through housing 61. For example, communication bus 65 may comprise a flexible circuit board including a proximal surface supporting elements of processing unit 60, and a distal surface including an electrical and/or optical network extending from power source 66 to the connectors 67. Any type of network may be used, such as a mesh network. Connectors 67 may be engageable with corresponding connectors of conductors 27 to provide at least one pathway for outputting control signal 82 from processing unit 60 to one or more generators 31, and/or electricity from power source 66 to one or more generators 31. Control signal 82 may include electrical and/or optical signals. For example, control signal 82 may include a string of output commands for each generator 31, and the entire string may be output to each generator 31 utilizing the electrical and/or optical signals, adding resiliency, in which the optical signals may be utilized for faster transmission.

As described above, the snap-fit connection between housing 61 and compartment 23 may place connectors 67 in communication with conductors 27, and maintain that communication over time, allowing for continuous output of control signals 82 from processing unit 60 and/or electricity from power source 66. A cover element may be attached to the proximal surface 24 of body 20 to seal processing unit 60 within compartment 23, and/or reinforce or supplant the snap-fit connection between housing 61 and compartment 23. For example, the cover may include a graphic design, a textual element, a writing surface, and/or like decorative feature. As a further example, the cover may provide a mounting surface for other technologies, such as an antenna, signal amplifier, and/or supplemental data transceiver.

Power source 66 may include any means for supplying electricity to processing unit 60 and/or the plurality of generators 31 (e.g., to each controller 34). As shown in FIG. 5, power source 66 may include a rechargeable battery, such as a lithium ion battery, chargeable by connection to an external power source, such as a wall outlet. Power source 66 may include power generation technologies. For example, a proximal surface of power source 66 may include a power generator, such as photovoltaic cells configured to charge the battery. As shown in FIG. 5, power source 66 also may include an optical energy source, such as a laser generator that is powered by power source 66 and configured to output optical energy to one or more generators 31 via optical pathways defined by communication bus 65 and conductors 27.

Aspects of attachment element 70 are now described with reference to FIG. 2C. As shown, attachment element 70 may be configured to maintain a position of tissue interface 30 against or adjacent skin 2. For example, element 70 may include an adhesive, elastic, and/or fastening element configured to apply a maintaining force in signal direction SD. In FIG. 2C, element 70 includes a proximal surface 72 adhered to the distal surface 24 of body 20, and a distal surface 74 adherable with skin 2. Distal surface 74 of element 70 may include a biocompatible adhesive configured to apply the maintaining force.

22

Attachment element 70 may be removably and/or semi-permanently attached to skin 2 by the biocompatible adhesive. For example, a first adhesive material may be used to attach the proximal surface 72 to distal surface 24, and a second adhesive material may be used to attach distal surface 74 to skin 2. As a further example, the first adhesive may be stronger so that energy transceiver 10 may be removed from skin 2 without separating surfaces 72 and 24. Either the first or second adhesive material may be biocompatible, and may include anti-bacterial and/or moisture resistant coatings and/or compositions configured for prolonged contact with skin 2. For example, at least the second adhesive material may be configured for contact with skin 2 during the entirety of a 4-hour, 8-hour, 12-hour, 24-hour shift, or longer shift. One or both adhesives also may be configured for semi-permanent contact with skin 2, such as during the entirety of a multi-month or multi-year treatment period. For example, at least the second adhesive material may include medicinal coatings and/or compositions that promote prolonged or semi-permanent contact with skin 2 by time-releasing treatments configured to prevent or minimize contact-based injuries.

Body 20 and/or attachment element 70 may be configured to boost the efficacy of energy signal 90 by minimizing and/or maintaining the distance between tissue interface 30 and skin 2, allowing signal 90 to be communicated with less energy. For example, any of the one or more energies 32 may be output through body 20 and/or attachment element 70. As shown in FIGS. 2B and 2C, attachment element 70 may include a plurality of openings 76. Each opening 76 may be sized approximate to one of communication bays 25, allowing the energies 32 to be output towards skin 2 in signal direction SD through openings 76. For example, each opening 76 may have an inner diameter approximate to an outer diameter of the communications bay 25 or housing 33 for each generator 31. As shown in FIG. 2C, attachment element 70 may have a thickness that allows tissue contact 39, electrical resistor 43, and/or electrical contacts 49 to contact skin 2 through opening 76 or be adjacent to skin 2 within opening 76.

Aspects of body 20 and/or attachment element 70 may direct and focus the energies 32, making it easier for the brain to distinguish one output of energies 32 from another. In keeping with previous examples, body 20 and attachment element 70 of FIGS. 2B and 2C may be composed of base materials including an impact absorbing material configured to absorb any excessive vibrations of skin 2 caused by impact energy 32A. One or both base materials may include an insulating material configured to direct heat energy 32B, electrical energy 32C, and pressure energy 32D through openings 76 along axis Z-Z; and prevent transmission of energies 32B, 32C, and 32D along axis X-X and Y-Y. For example, body 20 and element 70 of FIG. 2C may be configured to absorb any portion of energies 32 output incidentally in directions transverse to signal direction SD to promote signal distinction by limiting unwanted communications. As a further example, each opening 76 of attachment element 70 in FIG. 2C may have a reflective coating and/or a frustoconical interior shape centered about axis z-z to further focus the energies 32 towards skin 2.

As described herein, energy transceiver 10 may be operable to communicate energy signal 90 to skin 2 by outputting any energy 32, such as impact energy 32A, heat energy 32B, electrical energy 32C, and/or pressure energy 32D, individually or together. For example, any energies 32A-D may be used interchangeably or in combination to communicate any of the dots shown in FIG. 1A as symbols 92A, 92B, and 92C.

23

As now described, aspects of each energy 32 may be modified to increase the complexity of signal 90, and thus the amount of data transmitted therewith. Modifiable aspects may include energy type, energy intensity, output duration, scroll rate, symbol shape, and the like.

Energy signal 90 may be communicated to skin 2 with energies 32, individually or together. In FIG. 1A, for example, each dot within first symbol 92A may be output with impact energy 32A; each dot within second symbol 92B may be output with heat energy 32B; and each dot within third symbol 92C may be output with electrical energy 32C. The energies 32 may be combined for additional emphasis. For example, the first symbol 92A may be output with impact energy 32A in response to a baseline measure, and output with a combination of impact energy 32A and heat energy 32B if the measure changes. The energies 32 also may be combined to enhance the penetration depth of energy signal 90. For example, first symbol 92A may be formed by first outputting pressure energy 32D to activate a portion of the nerves associated with skin 2, and second outputting heat energy 32B to the activated nerves. Any individual dot may be similarly modified relative to any other dot.

The intensity of energies 32 may be modified for emphasis. For example, processing unit 60 may be configured to output first symbol 92A with impact energy 32A at a first intensity level in response to a baseline measure, and a second intensity level to highlight signal 92A if the measure changes. Output duration may be similarly modified. For example, the output duration of energies 32 may be instantaneous for normal measures, like a quick tap (e.g., about 100 ms); extended for abnormal measures, like a short hold (e.g., 500 ms to 1s); or a combination thereof, as with Morse code. Scroll rate may be similarly modified. For example, symbols 92 may not be scrolled at all (i.e., a scroll rate of zero), and output duration may be used to communicate change over time by flashing symbols 92 off and on in a fixed position. As a further example, in the healthcare setting, the scroll rate may be based on an update schedule (e.g., one revolution per minute), and/or the output duration may be based on patient status (e.g., faster for more critical patients).

Symbol shape also may be modified. The plurality of symbols 92 are shown as pip pattern shapes in FIG. 1A, but any symbol shape may be used, particularly those amenable to dot-matrix representation. For example, the plurality of symbols 92 may include known Morse code, binary symbols, lines, and/or directional arrows that are scrolled across communication area 4 in communication direction CD. Alphanumeric symbols also may be communicated. For example, input data 80 may include a control signal 82 generated from a Twitter® feed, and the symbols 92 may include alphanumeric symbols for communicating the author, date, and content of each Tweet® contained in the feed. As a further example, input data 80 may include the subject and sender of an email, and the signal generating program included in memory 64 may be configured to: prioritize the email based on the sender; and generate a control signal 82 for outputting a set symbols 92 based on the subject, sender, and priority of the email. For example, first symbols 92 may be output with impact energy 32A to communicate the subject and/or sender of prioritized emails in a shorthand notation, and at least one of heat energy 32B, electrical energy 32C, pressure energy 32D to communicate the priority level of the shorthand notation.

The resolution of tissue interface 30 may match or exceed the distinguishing capabilities of the nerves associated with

24

skin 2. For example, in the grid formation shown in FIG. 2B, the resolution of tissue interface 30 may be measured as energy output per square inch, which may exceed the natural energy receptivity limits of the nerves associated with skin 2. As shown, the resolution of interface 30 may be relative to the spacing between each bay 25, the configuration of body 20 and/or attachment element 70, and/or the intensity of energies 32. The energy receptivity limits of skin 2 may vary by location. For example, energy transceiver 10 may be attached to a portion of skin 2 located in a highly innervated or sensitive area, such as the face, allowing even more complex symbol shapes to be communicated.

With sufficient resolution, tissue interface 30 may likewise be configured to output signal 90 to replicate image patterns and/or other sensory perceptions with energies 32, including any of the symbols described herein and even more complex interactions. As described herein, the multi-energy capabilities of energy transceiver 10 may be configured to layer energies 32 so as to communicate far more complex image patterns and/or sensory perceptions that would otherwise be possible by communicating with a single energy because of the natural receptivity limits of the nerves, and their tendency to become less receptive during prolonged exposures.

Additional aspects of this disclosure are now described with reference to numerous additional examples of energy transceiver 10, including: an exemplary energy transceiver 110 shown conceptually in FIG. 6A; an exemplary energy transceiver 210 shown conceptually in FIG. 6B; an exemplary energy transceiver 310 shown conceptually in FIG. 6C; an exemplary energy transceiver 410 shown conceptually in FIG. 6D; an exemplary energy transceiver 510 shown conceptually in FIG. 7A; an exemplary energy transceiver 610 shown conceptually in FIG. 7B; an exemplary energy transceiver 710 shown conceptually in FIG. 7C; an exemplary energy transceiver 810 shown conceptually in FIG. 7D; and an exemplary energy transceiver 910 shown conceptually in FIGS. 9A-B.

Each variation of transceiver 10, such as transceivers 110, 210, 310, 410, 510, 610, 710, 810, 910, may include elements similar to those of transceiver 10, but within the respective 100, 200, 300, 400, 500, 600, 700, 800, or 900 series of numbers, whether or not those elements are depicted in FIGS. 6A through 9B. Any aspects described with references to transceivers 110, 210, 310, 410, 510, 610, 710, 810, and 910 may be included within any variation of transceiver 10 described herein, each possible combination or iteration being part of this disclosure. For example, any variation of transceiver 10 may comprise any combination of the wearable aspects of transceivers 110, 210, 310, and 410; the contact-based aspects of transceivers 510 and 610; and the implantable aspects of transceivers 710 and 810; and/or any multi-signal aspects of transceiver 910.

Additional wearable aspects are now described with reference to FIGS. 6A-D. As shown in FIG. 6A, energy transceiver 110 may include: a body 120 and a tissue interface 130, both shown conceptually with a dotted line; and an attachment element 170, shown conceptually as a sweat band. Any type of band may be used, such as a head band, an arm band, or a bandana. Body 120 may wrap around a portion of skin 2, such as circular portion of skin 2, like around a human forearm or forehead. As shown in FIG. 6A, body 120 may be mounted on attachment element 170; and tissue interface 130 may be mounted on a distal surface of body 120. For example, body 120 may be mounted on a distal surface of element 170; and tissue interface 130 may wrap around the circular portion of skin

25

2 with body 120, providing a curved rectangular communication area 4 and a semi-circular (e.g., less than 360°) or circular (e.g., 360°) communication direction CD for energy signal 90.

Attachment element 170 (e.g., a sweat band) may be configured to maintain tissue interface 130 against or adjacent a portion of skin 2, such as against the arm or forehead, allowing energy signal 90 to be output in signal direction SD and/or scrolled around the head to communication area 4 in communication direction CD. For example, the band may include an elastic portion that pushes body 120 and tissue interface 130 distally toward skin 2 when placed around the circular portion of skin 2, i.e., when the sweat band of FIG. 6A is worn. As shown, the elastic portion may be proximal of energy transceiver 110, attached to a proximal surface of body 120, and configured to apply a circumferential maintaining force that maintains the position of interface 130 when element 170 is worn.

As shown in FIG. 6B, energy transceiver 210 may include: a body 220 and a tissue interface 230, both shown conceptually with a dotted line; and an attachment element 270, shown conceptually as a baseball cap. Any cap, hat, helmet, or like headwear may be used. Body 220 may wrap around a circular portion of skin 2 including the forehead and/or scalp. As shown in FIG. 6B, body 220 may be mounted on attachment element 270; and tissue interface 230 may be mounted on a distal surface of body 220. For example, body 220 may be mounted on a distal surface of element 270; and tissue interface 230 may wrap around the circular portion of skin 2 with body 220, providing a semi-circular (e.g., less than 360°) or circular (e.g., 360°) communication area 4 and communication direction CD for energy signal 90. As a further example, body 220 and tissue interface 230 may have a semi-spherical shape covering interior surfaces of cap 270 for output of energy signal 90 to a semi-spherical communication area 4 of skin 2 in any communication direction(s) CD.

Similar to attachment element 170 of FIG. 6A, attachment element 270 (e.g., a cap) also may include an elastic or non-elastic portion configured to maintain tissue interface 230 against or adjacent a portion of skin 2, such as against the forehead, allowing energy signal 90 to be output in signal direction SD and/or scrolled around the head in communication direction CD. For example, the elastic or non-elastic portion may push body 220 and tissue interface 230 distally toward skin 2 when placed around the circular portion of skin 2, i.e., when the cap of FIG. 6B is worn. As shown, the elastic or non-elastic portion may be proximal of energy transceiver 210, attached to a proximal surface of body 220, and configured to apply a circumferential maintaining force that maintains the position of interface 230 when attachment element 270 is worn. For example, the elastic or non-elastic portion may comprise a tension fastening mechanism, such as any snaps, Velcro®, or other typically found on headwear.

As shown in FIG. 6C, energy transceiver 310 may include a body 320 and a tissue interface 330, both shown conceptually a dotted line; and an attachment element 370, shown conceptually as a sock. Any tube-like garment may be used, including gloves, shoes, stockings, and the like. Body 320 may wrap around a circular portion of skin 2, such as around a leg. As shown in FIG. 6C, body 320 may be mounted on attachment element 370; and tissue interface 330 may be mounted on a distal surface of body 320. For example, body 320 may be mounted on a distal surface of element 370, and tissue interface 330 may wrap around the circular portion of

26

skin 2 with body 320, providing a semi-circular (e.g., less than 360°) or circular (e.g., 360°) communication area 4 and direction(s) CD.

Similar to above, attachment element 370 (e.g., a sock) may include an elastic layer configured to maintain tissue interface 330 against or adjacent a portion of skin 2, such as against the leg, allowing energy signal 90 to be output in signal direction SD and/or scrolled around the head in communication direction CD. For example, the elastic layer may push body 320 and tissue interface 330 distally toward skin 2 when placed around the circular portion of skin 2, i.e., when the sock of FIG. 6C is worn. As before, the elastic layer may be proximal of energy transceiver 310, attached to a proximal surface of body 320, and configured to apply a circumferential maintaining force that maintains the position of interface 330 when attachment element 370 is worn.

As shown in FIG. 6C, transceiver 310 may be removably attached to attachment element 370, and thus operable with a plurality of elements 370, such as plurality of socks or other tube-like garments that typically become soiled during use. For example, element 370 may include a pouch configured to receive and secure body 320, orient tissue interface 330 toward skin 2, and/or maintain the position tissue interface 330 on or adjacent skin 2. As a further example, the elastic layer and/or the pouch may include an opening, and portions of body 320 may be engageable with (e.g., snap fit into) the opening to further maintain interface 330.

As shown in FIG. 6D, for example, energy transceiver 410 may include a body 420 and a tissue interface 430, both shown conceptually with a dotted line; and an attachment element 470, shown conceptually as a compression garment. Any type of compressive garment may be used, such as those made by Under Armour®. Body 420 of FIG. 6D may wrap around a portion of skin 2, and be composed of an impacting absorbing material (e.g., foam) configured to dissipate external impact forces directed toward the skin 2. For example, body 420 may be a thigh pad used in hockey or American football, a shin guard used in soccer, or any other type of protective pad with a distal surface that is desirably maintained against skin 2. Similar to above, body 420 may be mounted on attachment element 470; and tissue interface 430 may be mounted on a distal surface of body 420. For example, body 420 may be mounted on a distal surface of element 470; and tissue interface 430 may wrap around the circular portion of skin 2 with body 420, providing a curved communication area 4 and direction CD for signal 90.

Attachment element 470 (e.g., the compression garment) may include an elastic weave configured to maintain tissue interface 430 against or adjacent a portion of skin 2, such as against the arm or forehead, allowing energy signal 90 to be output in signal direction SD and/or scrolled around the head to communication area 4 in communication direction CD. For example, the elastic weave may push body 420 and tissue interface 430 distally toward skin 2 when placed around the circular portion of skin 2, i.e., when the compression garment of FIG. 6D is worn. In this example, the elastic weave may be attached to body 420, and configured to apply a circumferential maintaining force that maintains the position of interface 430 when attachment element 470 is worn.

Similar to above, energy transceiver 410 may be removably attached to attachment element 470, and thus operable with a plurality of elements 470, such as plurality of compressive garments. For example, impact absorbing body 420 may be mounted in a pocket of attachment element 470, and tissue interface 430 may be mounted on a distal surface

of impact absorbing body **420**, such as in a distal compartment of body **420**. Transceiver may be a game-time accessory. For example, as shown in FIG. 6D, signals **90** may comprise a plurality of arrows scrolled along communication direction CD to communicate movements to the user. In this example, the user may be trained to move in a particular direction (e.g., left or right) and intensity (e.g., slow or fast) based on the output of energy signal **90** and the particular combination of energies **32** associated therewith.

Although not shown in FIGS. 6A-D, attachment elements **170**, **270**, **370**, and **470** may include any adhesive and/or energy focusing elements, including those described above. For example, any aspects of attachment element **70** of FIG. 2C may be combined with any aspects of attachment elements **170**, **270**, **370**, or **470** of FIG. 6A-D to further maintain a position of tissue interface **430** relative to skin **2** and/or focus the energies **32** according to aspects of this disclosure. Aspects of any attachment elements may be combined and operable together. For example, attachment element **470** may include an opening, body **420** may be snapped into the opening, and a second attachment element (e.g., a biocompatible low-tack adhesive) may be configured to further fix the position of interface **430** relative to skin **2** during rigorous physical activity, such as running.

As described above, aspects of energy transceivers **110**, **210**, **310**, and **410** may be included with any wearable item, giving aspects of this disclosure incredible breadth. For example, aspects of any of attachment elements **170**, **270**, **370**, and **470** may be integrated into any wearable item including any type of band, strap, or like item including any combination elastic and/or non-elastic layers or portions. Exemplary attachment elements may include: bandages, wherein the tissue interface may be located on a distal surface of a skin-attachment portion; belts, wherein the tissue interface may be located on a distal surface of the belt; bras, wherein the tissue interface may be located on a distal surface of a bra strap; earrings, wherein the tissue interface may be located on a distal surface of an earring front or back; pants, wherein the tissue interface may be located on a distal surface of a waste line or seam; rings, wherein the tissue interface may be located on an interior distal surface; shirts, wherein the tissue interface may be located on a distal surface of a neckline; underwear, wherein the tissue interface may be located on a distal surface of the legs or waistline; watches, wherein the tissue interface may be located on a distal surface of the watch strap; and any known or obvious variation of the same.

Aspects of transceivers **10**, **110**, **210**, **310**, and **410** may be likewise included on any non-wearable object with a distal surface that is desirably maintained against skin **2** during use by application of an external force, such as a gravity force, a gripping force, or other externally applied maintaining force. Additional external force-based aspects are now described with reference energy transceiver **510** of FIG. 7A and energy transceiver **610** of FIG. 7B.

As shown in FIG. 7A, energy transceiver **510** may include: a body **520** and a tissue interface **530**, both shown conceptually with a dotted line; and an attachment element **570**, shown conceptually as a shoe or a shoe insert. Any type of footwear and/or foot support with equivalent surfaces may be used. Body **520** may include a surface contoured for placement against skin **2**, such as an underside of a foot. As shown in FIG. 7A, body **520** may be mounted on attachment element **570**; and tissue interface **530** may be mounted on or embedded in a distal portion of body **520**, allowing gravity to at least partially maintain interface **530** against or adjacent

skin **2**, and providing a foot-shaped communication area **4** and communication direction CD for energy signal **90**.

Attachment element **470** may additionally comprise any tensioning elements configured apply a maintaining force that maintains the position of interface **530** when attachment element **570** is worn, such as shoe laces, Velcro, pumping mechanisms, elastic straps or structures, and the like. As a further example, attachment element **570** may be composed of an impact absorbing material, such as a polymeric material configured to distribute forces around body **520** when walking or running; and include bolster shapes contoured to further maintain tissue interface **530** by limiting lateral movements of the foot relative thereto.

Accordingly, energy signal **90** may be communicated to the communication area **4** of skin **2** by tissue interface **530** in any communication direction CD with any combination of energies **32**. As shown in FIG. 7A, energy signal **90** may include a plurality of directional shapes (e.g., the arrows of FIG. 7A) flashed and/or scrolled in a linear direction to communication directional movements. The directional shapes may be responsive to directional data. For example, transceiver **510** may be configured to receive the directional data from one or more sources (e.g., GPS signals), determine communication direction CD based on the directional data, and scroll energy signal **90** across skin **2** as directional shapes scrolling along communication direction CD to compel movement of the user in a direction.

In keeping with above, transceiver **510** also may be configured to determine an importance measure based on the directional data, and communicate energy signal **90** with a particular combination of energies **32** and/or at a particular scroll rate based on the importance measure to direct a movement aspect, such as pace or direction. In the health-care setting, for example, the directional data may include a vital sign of a patient and the GPS location of the patient; and transceiver **510** may determine the scroll rate based on the vital sign, allowing energy signal **90** to guide a health-care provider toward the patient at walking pace appropriate for the condition of the patient. For example, energy signal **90** may be communicated a faster scroll rate with high intensity energies **32** to alert the provider to run if needed.

As shown in FIG. 7B, for example, energy transceiver **610** may include a body **620** and a tissue interface **630**, both shown conceptually with a dotted line; and an attachment element **670**, shown conceptually as a grip panel attached to the grip of a gun. Any type of gun may be used, including the handgun with a pistol grip and any other type of gun with similar surfaces that are gripped during use. In FIG. 7A, tissue interface **630** may be located on a distal surface of element **670** that is typically pushed toward a portion of skin **2** of a hand by a grip force applied by the hand during use, providing a regular or irregular shaped communication area **4**. Attachment element **630** may further maintain interface **630** by limiting movements the hand. For example, element **630** may be 3D printed based on a scan of the hand to include an outwardly curving surface shaped that maintains interface **630** against skin **2** by limiting movements of the hand relative to tissue interface **430** when gripped.

Accordingly, energy signal **90** may be communicated to the communication area **4** of skin **2** by tissue interface **630** in any communication direction CD with any combination of energies **32**. Aspects of energy signal **90** may be responsive to data, as with previous examples. For example, as shown in FIG. 7B, attachment element **670** (e.g., the gun) may include a sight, and energy signal **90** may include at least one decisional shape flashed and/or scrolled to communicate a status associated with gun based on a position of

the sight. For example, energy transceiver **610** may include an elevation or motion sensor, and signal **90** may be output to skin **2** as a first shape (e.g., a circle) with a first energy (e.g., any combination of energies **32A-D**) whenever the sensor indicates that the sight of the gun has been raised with the safety off, alerting the user to a status of the gun. As a further example, energy transceiver **10** and/or the gun may be configured to determine whether the sight is aligned with a specific target, and output signal **90** as a second shape (e.g., an X shape) with a second energy (e.g., any combination of energies **32A-D**), alerting the user to a status of the target.

Any individual or combined aspects of energy transceivers **10**, **110**, **210**, **310**, **410**, **510**, and **610** may likewise be included on any non-wearable object with a distal surface that is desirably maintained against skin **2** during use by application of an external force, such as a gravity, a gripping force, or other externally applied maintaining force. For example, aspects of tissue interfaces **510** and **610** may likewise be included on a distal surface of any load bearing surface of any type of attachment element. For example, aspects of attachment element **570** or **670** of FIGS. 7A-B alternatively may include a bar, a chair, a handle, a floor, a rope, a wall, or any like object with a skin facing surface that is generally maintained against skin **2** during use; and aspects of tissue interfaces **530** or **630** of FIGS. 7A-B alternatively may be mounted therewith so that energy signal **90** may be output to skin **2** whenever the alternative attachment element **570** or **670** is used.

Additional implantable aspects are now described with reference to energy transceiver **710** of FIG. 7C and energy transceiver **810** of FIG. 7D. As shown in FIG. 7C, for example, energy transceiver **710** may include a body **720** and a tissue interface **730**, both shown conceptually with a dotted line; and an attachment element **770**, shown conceptually as a portion of a bone plate. Any type of bone plate or other implantable object may be used. Attachment element **770** of FIG. 7C includes a proximal bone-facing surface and a distal skin-facing surface. The bone-facing surface may be maintained against the bone by any combination of adhesives, screws, wires, and/or other bone fixation technologies. The skin-facing surface may maintain the position of tissue interface **730** relative to the bone, allowing for movement of skin **2** relative to interface **730**. For example, tissue interface **730** may be mounted in a compartment on the skin-facing surface.

As above, energy signal **90** may be communicated to the communication area **4** of skin **2** by tissue interface **730** in any communication direction CD with any combination of energies **32**. As shown in FIG. 7C, signal **90** may include any combination of shapes moving in any communication direction CD, including any combination of shapes and/or directions, any of which may be flashed and/or scrolled with any energies **32**. In contrast to above, energy signal **90** of FIG. 7C may be output toward the underside of skin **2**, allowing for more direct communication with nerves associated with skin **2**. Aspects of transceiver **710** and energy signal **90** may be modified according to the implanted location of attachment element **770**. For example, tissue interface **730** may be embedded in an attachment element **770** sized for placement against a radius or finger bone wherein the distance between skin **2** and bone is minimal, allowing signal **90** to be communicated with less energy. As a further example, interface **730** may be mounted on an attachment element **770** sized for placement against a radius or ulna, wherein the distance between skin **2** and the bone is larger.

Similar to above, aspects of body **720** and/or attachment element **770** may direct and focus the energies **32**, making

it easier to distinguish one output of energies **32** from another and/or prevent the energies **32** from being output to bone. Alternatively, all or portion of the energies **32** may be output toward the bone-facing surface of element **770** to communicate signals and/or apply treatments to the bone. For example, the energies **32** may be output through body **720** and/or attachment element **770** in a proximal and/or distal direction, such as through a plurality of openings extending through element **770**. As a further example, the distal surface of body **720** may include a first tissue interface **730** and/or the bone-facing surface of body **730** may include a second tissue interface **730**, allowing a corresponding set of first and/or second energy signals **90** to be toward in a first direction toward skin **2** and/or a second direction toward the bone.

As shown in FIG. 7D, for example, energy transceiver **810** may include a body **820** and a tissue interface **830**, both shown conceptually with a dotted line; and an attachment element **870**, shown as a biocompatible outer surface layer surrounding body **820**. Any type of biocompatible material or containing structure may be used. In this example, attachment element **870** may comprise a tissue in-growth promoting exterior layer that maintains the orientation and/or position of tissue interface **830** over time by interacting with living tissue. For example, element **870** may be composed of a polymeric material, such as a variant of polyether ether ketone (or "PEEK"); and/or include an outer surface textured to promote tissue ingrowth.

Energy signal **90** may be output from tissue interface **830** as above. As shown in FIG. 7D, tissue interface **830** may be oriented so that the signals **90** are output through attachment element **870** and toward a communication area **4** under skin **2** in a signal direction SD. For example, aspects of body **820** and/or attachment element **870** may direct and focus the energies **32** toward discrete areas **4** on the underside of skin **2**, making it easier for the brain to distinguish one output of energies **32** from another and/or preventing the energies **32** from being output other living portions, such as bone or muscle. Alternatively, all or portion of the energies **32** may be output simultaneously from proximal and distal sides of element **870** to communicate with nerves associated with skin **2** and the other living portions. For example, the energies **32** may be output through body **820** and/or attachment element **870** in either direction through a plurality of openings extending therethrough. Also similar to above, transceiver **810** may include a first interface **830** disposed opposite a second interface **830**, allowing for output of a corresponding set of first and second energy signals **90**.

Additional aspects are now described with reference to energy transceiver **910** of FIGS. 8A and 8D, demonstrating that any variation of transceiver **10** described herein may be configured to output a plurality of signals **90**. For example, energy transceiver **910** may be configured to output a plurality of energy signals **90** in a signal direction SD toward skin **2**. As shown in in FIGS. 8A and 8B, transceiver **910** may output a first signal **990₁** in a first divided area or band **924₁**, and a second signal **990₂** in a second divided area or band **924₂**. Each signal **990₁** and **990₂** may include a plurality of symbols. In FIG. 8A, for example, the symbols include dots made visible through an exemplary cut-out in transceiver **910** as they would be communicated to skin **2**, similar to FIG. 1A. Likewise, some of the generators **931** are shaded in FIG. 8A indicate output of energies **32**, similar to FIG. 2B.

Transceiver **910** may comprise: a body **920**; a tissue interface **930**; a processing unit **960**; and an attachment element **970**. Similar to above, body **920** may contain

31

elements of transceiver 10 within a flexible biocompatible base material that is conformable against skin 2, and maintainable against skin 2 for prolonged and/or semi-permanent durations. As shown in FIGS. 8A and 8B, body 920 may have a length extending along a longitudinal axis X-X, a width extending along a lateral axis Y-Y, and a thickness extending along a proximal-distal axis Z-Z, similar to body 20 of FIGS. 2A-C. The length, width, and/or thickness of body 920 may be compatible with a curved portion of skin 2, as in FIG. 8A, where body 920 is curved along axis X-X. For example, body 920 may be curved and/or wrapped around any body shape, such as a human forearm, a human shin, and/or portions of a human torso.

As also shown in FIGS. 8A and 8B, body 920 may define a proximal surface 922, a distal surface 924, a distal compartment 926, and an interior conduit 928. The proximal surface 922 may include a cover 923 mounted thereto. Cover 923 may include a graphic design, a textual element, a writing surface, and/or like decorative feature. As shown in FIG. 8B, a distal surface of cover 923 may include a first attachment element (e.g., a first Velcro strip) engageable with a second attachment element (e.g., a second Velcro strip) on the proximal surface 922, allowing cover 923 to be switched-out as needed. The second attachment element also may attach body 920 to another object such as the inside of a garment.

Tissue interface 930 may be similar to any variation of tissue interface 30 described herein. As shown in FIG. 8B, tissue interface surface 930 may be mounted in the distal compartment 926 of body 920, and include plurality of energy generators 931 directed toward skin 2. Each generator 931 may be similar to generators 31 described above. For example, each generator 931 may be operable with processing unit 960 to output energies 32 individually and/or in combination in a signal direction SD; and contained with base material 933 (e.g., epoxy) that directs and/or focusses energies 32 in the signal direction SD. Each generator 931 may likewise include a plurality of generator elements arranged (e.g., coaxially) to output their respective energies 32 in approximately the same direction along an axis z-z, making the outputs interchangeable. As before, the energies 32 may include impact energy 32A (e.g., FIG. 4A), heat energy 32B (e.g., FIG. 4B), shock energy 32C (e.g., FIG. 4C), pressure energy 32D (e.g., FIG. 4D); and/or any like energies.

In contrast to above, the plurality of generators 931 may be arranged into a plurality of divided areas or bands. As shown in FIG. 8B, the width of body 920 along lateral axis Y-Y may include the first band 924₁ of generators 931, which may extend around the length of body 920 along a first longitudinal axis X₁-X₁ of transceiver 910; and the second band 924₂ of generators 931, which may extend around the length of body 20 along a second longitudinal axis X₂-X₂. The generators 931 located in first band 924₁ may be configured to output first signal 990₁, and the generators 931 located in second band 924₂ may be configured to output second signal 990₂. To enhance distinguishability, an interior portion of compartment 926 and/or base material 933 may physically separate first band 924₁ from second band 924₂, as in FIG. 8B.

As shown in FIG. 8A, processing unit 960 may be configured to: receive first input data 980A from a first data source 981A; receive second input data 980B from a second data source 981B; and output a control signal 982 and/or to electricity to generators 931, causing various combinations of said generators 931 to output first signal 990₁ and second signal 990₂. For example, processing unit 960 of FIGS. 8A

32

and 8B may include any elements of processor 60 of FIG. 5, such as transceiver 62, one or more processors 63, memory 64, communication bus 65, and power source 66. Each of these elements may perform a similar function within processing unit 960. Similar to above, one or more wired and/or wireless connections (e.g., such as conductors 27) may extend between processing unit 960 and each generator 931.

Attachment element 970 may maintain a position of tissue interface 930 against or adjacent skin 2. As shown in FIG. 8B, attachment element 970 may be proximal of tissue interface 930, and configured to maintain the position of interface 930 by applying a distally-directed force to body 920. The distally-directed force may press tissue interface 930 against skin 2, and/or cause portions of interface 930 to conform against a curvature of skin 2. As also shown in FIG. 8B, attachment element 970 may include a strap 972 extending through an interior conduit 928 of body 920. Strap 972 may apply the distally-directed force. For example, strap 972 may be composed of a resilient material (e.g., metal) having a cross-sectional shape (e.g., a semi-circular shape) that maintains body 920 in either an elongated configuration (e.g., FIGS. 2A-C) or a curved configuration (e.g., FIG. 8A), like a slap bracelet.

Attachment element 970 also may apply the distally-directed force by applying a tensile force to strap 972. As shown in FIG. 8A, a first end 973 of strap 972 may extend from one end of conduit 928, a second end 977 of strap 972 may extend from another end of conduit 928, and the tensile force may be imparted by removably attaching ends 973 and 974. For example, a proximal surface of the first end 973 may include a first attachment element (e.g., a first Velcro strip), a distal surface of second end 974 may include a second attachment element (e.g., a second Velcro strip), and the first and second attachment elements may be overlapped to impart the tensile force. Any type of attachment element may be used to attached ends 973 and 974, including buckles, ratchets, and the like. In some aspects, band 972 may be an elastic band, and ends 973 and 974 may be permanently attached together.

Processing unit 960 may be removably attached to transceiver 910, allowing for easy repairs and upgrades. As shown in FIG. 8A, processing unit 960 may be attached to a distal surface of the first end 973 of strap 972, and connected to tissue interface 930 by one or more conductors. For example, similar to conductors 27 described above, the conductors may include a network that is located in distal compartment 926 with tissue interface 930, and configured to transmit power and/or control signals between processing unit 960 and generators 931. As shown in FIG. 8A, a distal surface of processing unit 960 may include one or more sensors 968, and attachment element 970 may be configured to maintain a position of the one or more sensors 968 one or adjacent to skin 2, allowing characteristics of the user to be monitored and/or output with processing unit 960.

Signals 990₁ and 990₂ may be similar to signal 90 of FIG. 1A. For example, first signal 990₁ may include a plurality of first symbols output in first band 924₁, and second signal 990₂ may include a plurality of second symbols output in second band 924₂. As shown in FIGS. 8A and 8B, each of first and second symbols and/or dot may be associated with different data. For example, in the healthcare setting, first signal 990₁ may include first symbols associated with a first patient, and each first symbol may be associated with a vital sign for the first patient; whereas second signal 990₂ may include second symbols associated with a second patient, and each second symbol may be associated with a vital sign

for the second patient, allowing the user to simultaneously monitor the first and second patients with transceiver 910.

As shown in FIG. 8A, first signal 990₁ may be scrolled around first band 924₁ by outputting energies 32 toward skin 2 in signal direction SD, and moving the output across skin 2 in a first communication direction CD₁; and second signal 990₂ may be scrolled around second band 924₂ by outputting energies 32 toward skin 2 in signal direction SD, and moving the output across skin 2 in a second communication direction CD₂. Each signal 990₁ and 990₂, and/or each first or second symbol included therein, may be configured for increased complexity, allowing more data to be transmitted therewith. In keeping with the previous healthcare example, each signal 990₁ and 990₂ may be scrolled in one of communication directions CD₁ or CD₂ at a scroll rate associated with a vital sign of the respective first and second patients (e.g., pulse rate); each first and second symbol may be associated with another vital sign for said first and second patients (e.g., body temperature, pulse rate, respiration rate, and/or blood pressure); and the first and second symbols may be output with different combinations of energies 32 to communicate different aspects the vital signals (e.g., an increase or decrease in body temperature, pulse rate, respiration rate, and/or blood pressure).

Although shown as having two divided areas (e.g., first band 924₁ and second band 924₂) configured to output two different energy signals (e.g., first signal 990₁ and second signal 990₂), transceiver 910 may include any number of divided areas having any shape. For example, the width of body 920 may accommodate a plurality of divided areas, at least one tissue interface 930 may be located in each divide area, and attachment element 970 may be configured to maintain each tissue interface 930 against a different portion of skin 2. For example, body 920 of FIG. 8A may accommodate a plurality of bands spaced apart along a length of a limb (e.g., a forearm), and each band (e.g., similar to bands 924₁ and 924₂) may output a different energy signal (e.g., similar to signals 990₁ and 990₂) based on input data from a different data source (e.g., similar to sources 981₁ and 981₂). In a healthcare setting, each data source may include a patient monitoring device, allowing the user to simultaneously monitor a plurality of different patients with transceiver 910.

Various methods associated with transceiver 10 are now described, including methods of operating transceiver 10. Aspects of each method may be used with any variation of transceiver 10 described herein, such as transceivers 110, 210, 310, 410, 510, 610, 710, 810, and 910 described above. For ease of description, aspects these methods are now described with various references to these exemplary transceivers, including numerous references to energy transceiver 10. Unless claimed, these references are exemplary and non-limiting.

As shown in FIG. 9, an exemplary method 1000 may comprise: receiving, with processing unit 60, input data 80 for a communication device 10 including a tissue interface 30 maintainable on or adjacent skin 2, the interface 30 including a plurality of energy generators 31, each generator 31 being operable to output a plurality of energies 32 in a signal direction SD toward skin 2 (a receiving step 1020); and operating, with processing unit 60, the plurality of energy generators 31 to communicate with nerves associated with the skin 2 by outputting one or more energies (e.g., any of energies 32A, 32B, 32C, and 32D) of the plurality of energies 32 in the signal direction SD based on input data 80 (an operating step 1040).

Receiving step 1020 may comprise receiving input data 80 from one or more data sources 81. For example, the one or more data sources 81 may include at least one of patient monitoring device, a remote server, and a sensor. In this example, receiving step 1020 may comprise receiving input data 80 from the one or more data sources 81 at regular intervals, and operating step 1040 may comprise outputting the one or more energies based on the input data 80 received during each regular interval.

Input data 80 may include a control signal 80, and operating step 1040 may comprise outputting the one or more energies based on the control signal 82. Alternatively, method 1000 may comprise: generating, with processing unit 60, control signal 82 based on input data 80, wherein operating step 1040 may comprise outputting the one or more energies based on control signal 82. For example, the generating step 1030 may include associating the input data 80 with a plurality of symbols 92, and operating step 1040 may comprise communicating the symbols 92 with the one or more energies. In this example, the input data 80 may include measurements (e.g., vital signs of a patient), and each symbol may be associated with one or more of the measurements (e.g., one or more of the vital signs).

In any of these examples, the one or more energies may include a first combination of the plurality of energies 32 (e.g., impact energy 32A and pressure energy 32D); and a second combination of the plurality of energies 32 (e.g., heat energy 32B and pressure energy 32D). The first combination may be followed by any second combination(s). For example, the one or more energies may include a first energy (e.g., impact energy 32A) communicable with a first portion of the nerves (e.g., Meissner's corpuscle); and a second energy (e.g., heat energy 32D) communication with a second portion of the nerves (e.g., the Ruffini corpuscle).

Operating step 1040 may alternatively comprise: operating, with processing unit 60, the plurality of energy generators 31 to communicate energy signal 90 to nerves associated with the skin 2 by outputting one or more energies of the plurality of energies 32 in signal direction SD based on input data 80. For example, step 1040 may comprise outputting different combinations of the one or more energies, and each different combination may communicate a different portion of the energy signal 90. Similar to above, energy signal 90 may include one or more symbols 92, and operating step 1040 may comprise outputting the one or more energies to communicate the one or more symbols 92. Step 1040 may comprise scrolling the one or more symbols 92 across skin 2 in a communication direction CD transverse with the signal direction SD; and/or flashing any of symbols 92 on-and-off. The plurality symbols 92 may include any type of signal, including pip patters, alphanumeric symbols, and the like.

Various energy types may be used. For example, operating step 1040 may comprise outputting a first combination of the one or more energies to communicate a first symbol of the one or more symbols (e.g., symbol 92A), and outputting a second combination of the one or more energies to communicate a second symbol of the one or more symbols (e.g., symbol 92B). In some aspects, operating step 1040 may comprise: outputting a first combination of the one or more energies to communicate energy signal 90 and outputting a second combination of the one or more energies to communicate a characteristic of energy signal 90, so as to highlight energy signal 90 or a portion thereof. Input data 80 may include a measurement, and step 1040 may comprise outputting a first combination of the one or more energies based on the measurement. In this example, step 1040 may

comprise modifying the first combination based on a change of the measurement, and/or outputting a second combination of the one or more energies based on the change of the measurement.

The larger size of transceiver **910** relative to transceivers **10** may allow for different methods of operation. As shown in FIG. **10**, for example, an exemplary method **1100** may comprise: receiving, with processing unit **960**, input data **980** for a communication device **910** including a tissue interface **930** maintainable on or adjacent skin **2**, the interface **930** including a plurality of energy generators **931** arranged in bands **924₁** and **924₂**, each generator **931** being operable to output a plurality of energies **32** in a signal direction SD toward the skin **2** (a receiving step **1120**); and operating, with processing unit **60**, the plurality of energy generators **931** in each band **924₁** and **924₂** to communicate with nerves associated with the skin **2** by outputting one or more energies of the plurality of energies **32** in response to the input data **80** (an operating step **1140**).

Receiving step **1020** may comprise receiving input data **980** from one or more data sources **981**. As shown in FIG. **10**, for example, step **1020** may comprise receiving a first input data **980A** from a first data source **981A**, and a second input data **980B** from a second data source **981B**. Input data **980** may include a plurality of measurements. Accordingly, receiving step **1020** may comprise receiving input data include a plurality of measurements; and operating step **1040** may comprise operating the plurality of energy generators **931** in each band **924₁** and/or **924₂** to output the one or more energies based on one measurement of the plurality of measurements.

In the healthcare setting, first data source **981A** may include a patient monitoring device or sensor configured to output measurements associated with a first patient, and second data source **981AB** may include a patient monitoring device or sensor configured to output measurements associated with a second patient. The measurements may include vital signs for the respective first and second patients. In this example, receiving step **1120** may comprise receiving input data **980** including a plurality of vital signs; and operating step **1140** may comprise operating the plurality of energy generators **931** in each band **924₁** and **924₂** to output the one or more energies based on one vital sign of the plurality of vital signs. For example, step **1140** may comprise operating the generators **931** in band **924₁** to output energies **32** based on the vital signs for the first patient, and/or operating the generators **931** in band **924₂** to output energies **32** based on the vital signs for the second patient.

Aspects of energies **32** may be modified based on the measurements. For example, operating step **1040** may comprise: outputting a first combination of energies **32** when the at least one of the measurements is inside of an acceptable range; and outputting a second combination of energies **32** when at least one of the measurements is outside of the acceptable range. In the healthcare setting, one of the vital signs of the patient (e.g., pulse rate) may serve as the baseline measure.

Similar to above, input data **980** may include a control signal for each band **924₁** and **924₂**, and operating step **1140** may comprise outputting the energies **32** based on the control signal for each band **924₁** or **924₂**. Alternatively, method **1100** may further comprise: generating, with the processing unit **960**, a control signal for each band **924₁** and **924₂** based on input data **980**, wherein the operating step **1140** comprises outputting the energies **32** based on the control signal for each band.

Also similar to above, operating step **1140** also may comprise operating the plurality of energy generators **931** to simultaneously communicate a plurality of energy signals to nerves associated with the skin **2** by outputting an energy signal in each band with energies **32**, and/or scrolling the energy signal in its respective band. As shown in FIG. **10**, step **1140** may comprise outputting first energy signal **990₁** in first band **924₁** with a first combination of energies **32**, and outputting second energy signal **990₂** in second band **924₂** with a second combination of energies **32**. Each signal **990₁** and **990₂** may include a plurality of symbols (e.g., symbols **92**), and operating step **1140** may comprise scrolling the symbols across one of bands **924₁** and **924₂**. In keeping with above, first signal **990₁** (and any symbols contained therein) may be scrolled along a first communication direction CD₁ transverse with signal direction SD, and second signal **990₂** (and any symbols contained therein) may be scrolled along a second communication direction CD₂ transverse with signal direction SD.

Although described with reference to two divided areas (e.g., first band **924₁** and second band **924₂**) configured to output two energy signals (e.g., first signal **990₁** and second signal **990₂**), it is contemplated that method **1100** may be configured for any number of divided areas. Accordingly, variations of method **1100** may allow the user to simultaneously monitor a plurality of sources of input data, from one or more data sources, with aspects of transceiver **910** described herein.

Additional aspects described above with reference to transceivers **10**, **110**, **210**, **310**, **410**, **510**, **610**, **710**, **810** and **910**, and methods **1000** and **1100**, are now described with reference to a communication system **2000**. Aspects of an exemplary system **2000** are depicted in FIGS. **11** and **12**. As shown in FIG. **11**, communication system **2000** may comprise a plurality of energy transceivers configured to receive input data and output one or more of a plurality of energies **32** to different locations of skin **2** according to the input data. Each transceiver may include any element and perform any function described above with reference to transceivers **10**, **110**, **210**, **310**, **410**, **510**, **610**, **710**, **810** and **910**, and methods **1000** and **1100**. Different aspects may be combined in system **2000**. For example, as shown in FIG. **11**, system **2000** may comprise: a first energy transceiver **2012** on a head of a user **1**, similar to transceiver **110** of FIG. **6A**; a second energy transceiver **2014** on one arm of user **1**, similar to transceiver **900** of FIGS. **9A-B**; a plurality of energy transceivers **2016** attached to a torso of user **1**, similar to transceiver **10** of FIGS. **2A-C**; an energy transceiver **2018** on each leg of user **1**, similar to transceiver **410** of FIG. **6D**; and an energy transceiver **2020** in each shoe of user **1**, similar to transceiver **510** of FIG. **7A**.

Each transceiver **2012**, **2014**, **2016**, **2018**, and **2020** may be interconnected in system **2000** so that coordinated control signals may be output to each transceiver for output of a corresponding signal **90** with a corresponding one or more of energies **32**. The coordinated control signals may be used to coordinate activities or movements of user **1** in response to the input data. As shown in FIG. **11**, each of said transceivers may output data associated with a first form or position of user **1**, receive input data regarding a second form or position, and output signals **90** in the same or communication directions CD to direct the user **1** to move according to the desired form or position. In one aspect, the first form or position may be a first pose or stance, and the second form or position may be a second pose; in other aspects, the first form or position may be a first (e.g., GPS)

position on a field, and the second form or position may be a second (e.g., GPS) position on the field.

As shown in FIG. 11, for example, transceiver 2012 may scroll a first signal 90 in a first communication direction CD₁ around the head; transceiver 2014 may scroll a second signal 90 around the arm in a second communication direction CD₂; transceivers 2016 may output third signals 90 without scrolling; transceivers 2018 may scroll fourth signals 90 in communication directions CD_{3R} and CD_{3L} around the legs; transceivers 2020 may scroll fourth signals 90 in communication directions CD_{4R} and CD_{4L} across the feet. Accordingly, each of the respective signals and communication directions may be coordinated in system 2000 to direct the user to move in a particular direction and/or move one or more of their limbs into a particular form or position.

Aspects of methods 1000 and 1100 may be modified for use within system 2000. As shown in FIG. 12, for example, an exemplary method 2100 may comprise: receiving, with one or more processors, position data for a plurality of communication devices (e.g., transceivers 2012, 2014, 2016, 2018, 2020) mountable on or adjacent skin, each device including a tissue interface with a plurality of energy generators 31, each generator 31 being operable to output a plurality of energies 32 in a signal direction SD toward skin 2 (a “receiving step 2120”); receiving or generating, with the one or more processors, a corrective motion signal for the plurality of communication devices based on position data for each communication device (a “receiving or generating step 2140”); and operating, with the one or more processors, the plurality of energy generators 31 of each communication device to output one or more energies of the plurality of energies 32 in signal direction SD based on the corrective motion signal. Although described with reference to elements of transceiver 10, method 2100 may be performed with any transceiver described herein.

Additional aspects described above with reference to transceivers 10, 110, 210, 310, 410, 510, 610, 710, 810 and 910, methods 1000 and 1100, system 2000, and method 2100 are now described with reference to aspects of an energy transceiver 3010 shown in FIGS. 13A, 13B, 14A, and 14B. As before, any aspect of energy transceiver 3010 may be combined with any aspect described above.

As shown in FIG. 13A, energy transceiver 3010 may include: a body 3020 and a tissue interface 2030; and an attachment element 3070, shown conceptually as a band in this example. As above, body 3020 may wrap around a circular portion of skin 2, such as around the human forearm shown in FIG. 13B. For example, as before, body 3020 may be mounted on attachment element 3070; and tissue interface 3030 may be mounted on a distal surface of body 3020, providing a curved rectangular communication area 4 and a semi-circular (e.g., less than 360°) or circular (e.g., 360°) communication direction CD for energy signal 90. In keeping with above, attachment element 3070 (e.g., the band) may be configured to maintain tissue interface 3030 against or the forearm when element 3070 is worn, allowing energy signal 90 to be output communication area 4 in signal direction SD and/or scrolled across area 4 in communication direction CD.

As described above, aspects of each energy 32 may be modified to increase the complexity of energy signal 90, and thus the amount of data transmitted therewith; and the modifiable aspects may include energy type, energy intensity, output duration, scroll rate, symbol shape, and the like, providing an incredibly broad range of obtainable complexity. Training may be required to leverage the full communicative capabilities of tissue interface 3030 and signal 90.

For example, within a repetition program, the user may be trained to more easily and/or quickly to distinguish between: any number of known shapes output by one of energies 32, such as between a pip two dot pattern output with impact energy 32A and a pip four dot pattern output with energy 32A; or the same shape output with different energies 32, such as a pip five dot pattern with impact energy 32A or heat energy 32B.

Communicating more complex variations, unknown signals, and/or unknown shapes may require additional training. For example, interface 3030 may output energy signal 90 to include pip patterns in which each dot is output with a different combination of energies 32, allowing the pattern to be associated with a target, and each dot to be associated with a characteristic thereof. In the healthcare setting, for example, the pattern may be associated with a patient, and each dot may be associated with a different vital sign of the patient, providing immediate insight into patient health that may be updated continuously. Further training may be required to quickly distinguish between the characteristics communicated by each dot in these examples, particularly if energy signal 90 includes a plurality of pip patterns, as shown in FIG. 2C; or a dynamic shape, such as the echocardiogram depicted in FIGS. 13A and 13B; the plurality of echocardiograms depicted in FIG. 14A; or the alphanumeric symbol stream depicted in FIG. 14B.

Aspects of energy transceiver 3010 may be configured to provide additional communicative capabilities to, for example, assist with training. As shown in FIG. 13A, transceiver 3010 may further comprise an optical interface 3030' compatible with eyes of the user. For example, optical interface 3030' may comprise at least one display element operable to output an optical energy signal 90' to the eyes, such as a flexible LED configured to output a plurality of colors. Any display technology may be used. As shown in FIG. 13A, interface 3030' may provide a curved optical communication area that wraps around apparatus 3010 along an axis X-X and/or substantially corresponds with the communication area 4. For example, tissue interface 330 may be configured to output non-optical energy signal 90 toward skin 2 with one or more energies 32 in a first or distal direction toward skin 2; and optical interface 330' may be configured to output optical signal 90' with one or more colors in a second or proximal direction toward the eyes.

Energy transceiver 3010 may comprise a processing unit similar to any variation of processing unit 60 described herein. For example, the processing unit may be operable with tissue interface 3030 and optical interface 3030' to simultaneously communicate with nerves associated with skin 2 and the eyes by outputting signal 90 distally and signal 90' proximally at the same time. Additional training capabilities may be realized by the simultaneous outputs. For example, the user may already be trained to react to optical signal 90', whether or not signal 90 is communicated, such as when transceiver 3010 excludes interface 3030. Accordingly, by consistently outputting energy signal 90 with optical signal 90', the user may be trained to react to recognize and react to energy signal 90 with or without optical signal 90'.

In a healthcare setting, for example, optical signal 90' may communicate a vital sign of a patient to the eyes of a provider, such as the echocardiogram of FIG. 13A; and energy signal 90' may communicate the same vital sign to skin 2 of the provider at the same time. For example, signals 90' and 90 may be scrolled together in communication direction CD along axis X-X to simultaneously communicate aspects of the vital sign over time. As a further example,

signal 90' may comprise a plurality of colors, and the output of energies 32 in signal 90 may be modified according to a color matching algorithm to communicate similar aspects to skin 2 at the same time. Reactions to different vital signs may be trained in this manner. As shown in FIG. 13B, for example, a first portion of optical interface 3030' may output a first optical signal 90A', a second portion of interface 3030' may output a second optical signal 90B', corresponding portions of tissue interface 3030 may output corresponding energy signals 90, much like interface 930 described above. As also shown in FIG. 13B, the signals 90A' and 90B' may be different, in which one may be a vital sign and other may include symbols communicating related patient data as above.

Accordingly, by simultaneously outputting optical signal 90' together with energy signal 90, transceiver 3010 may train reactions to any stimulus, such as the exemplary vital signs and signals depicted in FIGS. 13 and 13B. As shown in FIGS. 14A and 14B, the complexity of the stimulus may be increased. For example, as shown in FIG. 14A, optical interface 3030' and tissue interface 3030 may output their respective signals in a plurality of rows arranged around axis X-X, wherein each row includes a different set of corresponding signals movable along a communication direction CD that is transverse with axis X-X. In this example, four rows are shown as outputting four different optical signals, including a first optical signal 90A', a second optical signal 90B', a third optical signal 90C', and a fourth optical signal 90D'. A corresponding set of rows and outputs may be realized by tissue interface 90.

In the healthcare setting, for example, each output of optical signals 90A', 90B', 90C' and 90D' together with its corresponding energy signal 90 may communicate a different vital sign of a different patient to a provider, training them to simultaneously monitor all of the different patients at once. As described above, aspects of each energy signal 90, such as energies 32, may be modified to communicate changes in the associated vital sign. For training purposes, the color of optical signals 90A, 90B, 90C, and 90D may be varied based on these changes so that the provider may be trained to first recognize the changes based one of the optical signals; and second recognize the same changes based on one of the energy signals based on the color matching algorithm. For example, the color matching algorithm may comprise a correspondence between visual colors and energy intensity, in which warmer colors (e.g., red) are associated with higher intensities and cooler colors (e.g., blue) are associated with lower intensities.

Another example is provided in FIG. 14B, in which each output of signals 90A', 90B', 90C' and 90D' together with its corresponding signal 90 may communicate aspects of an alphanumeric stream. As shown in FIG. 14B, for example, each alphanumeric stream may comprise a stock ticker so that the user may be trained to simultaneously monitor a plurality of tickers. As before, aspects of the different optical signals 90A', 90B', 90C', and 90D' may be modified simultaneously with aspects of their corresponding energy signals 90 to communicate changes over time.

In keeping with above, optical interface 3030' and tissue interface 3030 may be configured to individually and/or simultaneously output signals 90' and 90 to include any symbols and shapes, as well as more complex depictions, such as graphics. For example, for more complex depictions, the color matching algorithm may be used to output different combinations of energies 32 based on color.

Optical interface 3030' may comprise touchscreen capabilities allowing manipulation of signals 90 and/or 90' by

interaction therewith. For example, the position of each row depicted in FIGS. 14A and 14B may be movable via a tactile interaction with interface 3030'. As shown in FIG. 13B, for example, attachment element 3070 may maintain the position of tissue interface 3030 on or adjacent skin 2 of a forearm, meaning that at least some portion of optical interface 3030' may not be aligned with the eyes of the user at all times. Accordingly, because of the dynamic capabilities of interfaces 3030 and 3030', the touchscreen capabilities of apparatus 3010 may allow the user to move a particular row into alignment with the eyes by scrolling the rows together around axis X-X, in which the outputs of signals 90A', 90B', 90C', and 90D' and corresponding energy signal 90 move with each row. Any type of touchscreen-enabled two-way communication means may be used, including buttons, sliders, textual inputs, graphic inputs, and the like.

Aspects of methods 1000, 1100, and 2100 and/or system 200 may be modified according to aspects of energy transceiver 3010. For example, any method steps described herein may be modified to comprise training and/or communication steps according to the above-described aspects of transceiver 3010. As a further example, the second energy transceiver 2014 shown in FIG. 11 may comprise transceiver 3010, which may be further operable with each of transceivers 2012, 2016, 2018, and 2020 to train the user. To provide another example, aspects of each transceiver within system 2000 also may be configured to placement at a particular sensory zone of skin 2, and transceiver 3010 may be used to both tune the respective energy signals 90 for output to each zone and train the user to react accordingly based on one or more of the signals 90. In this example, the receptive capabilities of the nerves associated with skin 2 in each zone may vary, and transceiver 3010 may be configured to operate the transceivers in system 2000 so that the most complex signals are communicated to the most receptive zones.

While principles of the present disclosure are disclosed herein with reference to illustrative aspects for particular applications, the disclosure is not limited thereto. Those having ordinary skill in the art and access to the teachings provided herein will recognize additional modifications, applications, aspects, and substitution of equivalents all fall in the scope of the aspects disclosed herein. Accordingly, the present disclosure is not to be considered as limited by the foregoing description.

The invention claimed is:

1. A treatment device, comprising:

a body provided with a processing unit and a power source; and

a plurality of energy generator elements being independently operable to convert electricity from the power source into a plurality of different energy types transmittable towards an area of skin of a user, the plurality of energy generator elements being arranged coaxially about an axis,

wherein the body includes a grip arranged to be grasped by a hand of the user applying a gripping force to maintain the plurality of energy generator elements on or adjacent the area of skin,

wherein the plurality of energy generator elements includes a first energy generator element and a second energy generator element, and wherein the first energy generator element is an impact generator element having a tissue contact surface that is linearly actuatable along the axis to contact and cause corresponding physical movement of the area of skin.

41

2. The treatment device of claim 1, wherein the impact generator element further includes a drive mechanism and a piston, wherein the drive mechanism is operably coupled to a controller that directs electricity to the drive mechanism to move the piston and the tissue contact surface along the axis.

3. The treatment device of claim 1, wherein the second energy generator element is substantially ring shaped and arranged coaxially about the first energy generator element.

4. The treatment device of claim 1, wherein the second energy generator element includes a reflecting groove circumferentially arranged about the axis, the reflecting groove defining a concave shape arranged to reflect energy generated from the second energy generator element towards the area of skin.

5. The treatment device of claim 1, wherein the second energy generator element includes a heat generator element.

6. The treatment device of claim 1, wherein a first one of the plurality of different energy types is an impact force applied against a surface of the area of skin and a second one of the plurality of different energy types is a heat flux directed toward the area of skin.

7. The treatment device of claim 1, wherein at least one of the plurality of energy generator elements is contained at least partially within a housing that is removably securable to the body.

8. A treatment device, comprising:

a body provided with a sensor, a power source, and a processing unit configured to receive input data and generate a control signal based on the input data, the body further including a skin contacting surface maintainable against skin of a user by a force applied by a hand of the user when gripping the body; and

a first energy generator element and a second energy generator element coupled to the body, the first and second energy generator elements being independently operable to convert electricity from the power source into a first energy type and a second energy type, respectively, and direct the first and second energy types toward an area of skin, the first energy generator element including an impact generator element having a tissue contact surface that is linearly actuatable along an axis to contact and cause corresponding physical movement of the area of skin,

wherein the sensor is configured to detect additional input data based on a vital sign of the user and transmit the input data for display.

9. The treatment device of claim 8, wherein the additional input data corresponds to a heart rate of the user.

10. The treatment device of claim 8, further comprising a controller configured to modify intensity of the first energy type and the second energy type.

11. The treatment device of claim 8, wherein a portion of the body configured to be gripped by the hand of the user is configured to emulate a grip of a gun.

12. The treatment device of claim 8, wherein the impact generator element further includes a drive mechanism and a piston, wherein the drive mechanism is operably coupled to a controller to direct electricity to the drive mechanism and move the piston and the tissue contacting surface along the axis.

13. The treatment device of claim 12, wherein the second energy generator element is a heat generator element configured to output the second energy type including a heat flux toward the area of skin.

42

14. The treatment device of claim 13, wherein the heat generator element is arranged coaxially about the axis and at least a portion of the heat generator element extends about at least portion of the piston.

15. The treatment device of claim 13, further comprising a third energy generator element independently operable of the first and second energy generator elements to output a third energy type toward the area of skin.

16. The treatment device of claim 15, further comprising a controller configured to modify an intensity of the first, second, and third energy types.

17. A treatment device, comprising:

a body provided with a power source and a processing unit configured to receive input data and generate a control signal based on the input data, the body including a skin contacting surface maintainable against skin of a user by a force applied by a hand of the user when gripping the body; and

a first energy generator element and a second energy generator element coupled to the body, the first and second energy generator elements being independently operable to convert electricity from the power source into a first energy type and a second energy type, respectively, and direct the first and second energy types toward an area of skin, the first energy generator element including an impact generator element having a tissue contact surface that is linearly actuatable along an axis to contact and cause corresponding physical movement of the area of skin;

wherein the processing unit is operable to output an optical signal on a display that is observable by eyes of the user, the output corresponding to the control signal.

18. The treatment device of claim 17, wherein a portion of the body configured to be gripped by the hand of the user is configured to emulate a grip of a gun.

19. The treatment device of claim 17, further comprising a sensor to detect additional input data based on a vital sign of the user, the additional input data corresponding to a heart rate of the user.

20. A treatment method, comprising:

maintaining a skin contacting surface of a body against an area of skin of a user by gripping the body with a hand and applying a gripping force with the hand, the body comprising a plurality of energy generator elements that are independently operable to output a plurality of different energy types toward the area of skin; and

causing, with a processing unit and a power source, while maintaining the skin contacting surface against the skin with the gripping force, the plurality of energy generator elements to convert electricity from the power source into the plurality of different energy types by independently or simultaneously causing:

a first energy generator element having the tissue contact surface that is linearly actuatable along an axis to output a first energy type as the tissue contact surface contacts and causes corresponding physical movement of the area of skin; and

a second energy generator element that is arranged coaxially about the first energy generator element along the axis to output a second energy type to the area of skin.

21. The method of claim 20, comprising independently or simultaneously causing, with the processing unit:

the first energy type to stimulate touch receptors associated with the area of skin; and

the second energy type to stimulate thermal receptors associated with the area of skin.

43

22. The method of claim 20, wherein causing the first energy generator element to output the first energy type comprises:

causing, with the processing unit, a drive mechanism to move a piston linearly along the axis so that the tissue contact surface attached to the piston applies an impact force against the area of skin.

23. The method of claim 20, wherein causing the second energy generator element to output the second energy type comprises:

directing the second energy type coaxially about the first energy generator element toward the area of skin.

24. The method of claim 20, wherein the second energy type comprises a heat flux and causing the second energy generator element to output the second energy type comprises:

causing, with a controller, an electrical resistor to output the heat flux; and

directing the heat flux toward the area of skin.

44

25. The method of claim 20, comprising: receiving, with the processing unit, input data from a data source;

generating, with the processing unit, a control signal based on the input data; and

causing, with the processing unit, the plurality of energy generator elements to output the plurality of different energy types responsive to the control signal.

26. The method of claim 25, comprising:

detecting, with a sensor, additional input data based on a vital sign of the user; and

transmitting, with the sensor, the additional input data to the processing unit.

27. The method of claim 26, comprising:

modifying, with the processing unit, an intensity of the first energy type or the second energy type responsive to the input data or the additional input data.

28. The method of claim 20, comprising independently or simultaneously causing a third generator element to output a third energy type to the area of skin.

* * * * *