



US007453852B2

(12) **United States Patent**  
**Buddhikot et al.**

(10) **Patent No.:** **US 7,453,852 B2**  
(45) **Date of Patent:** **Nov. 18, 2008**

(54) **METHOD AND SYSTEM FOR MOBILITY ACROSS HETEROGENEOUS ADDRESS SPACES**

2004/0028009 A1\* 2/2004 Dorenbosch et al. .... 370/329  
2004/0085931 A1\* 5/2004 Rezaifar ..... 370/331  
2004/0203765 A1\* 10/2004 Das et al. .... 455/435.1

(75) Inventors: **Milind M. Buddhikot**, Cliffwood, NJ (US); **Adishesu Hari**, Matawan, NJ (US); **Scott C. Miller**, Freehold, NJ (US); **Kundan Narendra Singh**, New York, NY (US)

**OTHER PUBLICATIONS**

VIP: A Protocol Providing Host Mobility (Communications of the ACM, Aug. 1994).\*

Bhagwat, Pravin, Perkin, Charles, and Tripathi, Satish, "Network Layer Mobility: An Architecture and Survey," *IEEE Personal Communications*, 11 pages, Jun. 1996.

Braun, Torsten, Einsiedler, Hans Joachim, Scheidegger, Matthias, Stattenberger, Günther, "A Linux Implementation of a Differentiated Services Router," Institute of Computer Science and Applied Mathematics, University of Berne, 12 pages.

(73) Assignee: **Lucent Technologies Inc.**, Murray Hill, NJ (US)

(\* ) Notice: Subject to any disclaimer, the term of this patent is extended or adjusted under 35 U.S.C. 154(b) by 1015 days.

(Continued)

(21) Appl. No.: **10/618,880**

*Primary Examiner*—Chau Nguyen  
*Assistant Examiner*—Eunsook Choi

(22) Filed: **Jul. 14, 2003**

(65) **Prior Publication Data**

US 2005/0013280 A1 Jan. 20, 2005

(57) **ABSTRACT**

(51) **Int. Cl.**  
**H04Q 7/00** (2006.01)

(52) **U.S. Cl.** ..... **370/331; 370/401**

(58) **Field of Classification Search** ..... 370/349  
See application file for complete search history.

A mobile node includes a processor, a network interface, and a storage device having computer program code for execution by the processor. The computer program code includes a network layer for transmitting and receiving packets and an intermediate driver that transmits packets to the network layer and receives packets from the network layer using a virtual internet protocol (IP) address to identify the mobile node. The intermediate driver transmits packets to the network interface and receives packets from the network interface using a routable actual IP address to identify the mobile node. The intermediate driver permits the actual IP address to change when the mobile node moves from a first subnet to a second subnet without a corresponding change in the virtual IP address. A corresponding NAT associates the virtual IP address with a second actual IP address when the NAT is notified that the mobile node is in the second subnet.

(56) **References Cited**

**U.S. PATENT DOCUMENTS**

- 6,317,028 B1 11/2001 Valiulis ..... 340/10.1
- 6,345,043 B1 2/2002 Hsu ..... 370/324
- 6,442,616 B1\* 8/2002 Inoue et al. .... 709/245
- 6,680,923 B1 1/2004 Leon
- 2001/0048744 A1 12/2001 Kimura ..... 380/247
- 2002/0154624 A1\* 10/2002 Oishi et al. .... 370/350
- 2003/0172142 A1\* 9/2003 Su ..... 709/223
- 2003/0179775 A1\* 9/2003 Carolan et al. .... 370/469
- 2003/0212821 A1\* 11/2003 Gillies et al. .... 709/238

**24 Claims, 15 Drawing Sheets**

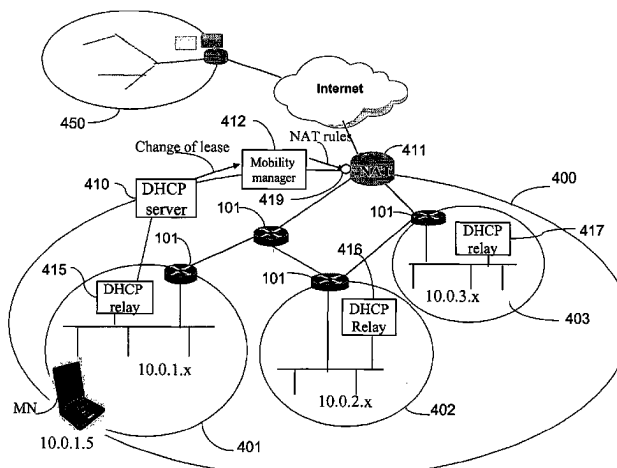

OTHER PUBLICATIONS

Dornan, Andy, "CDMA and 3G Cellular Networks," [www.networkmagazine.com/article/NMG.html20000831S0006.html](http://www.networkmagazine.com/article/NMG.html20000831S0006.html), 4 pages, visited Mar. 31, 2003.

Hayes, Vic, Chair IEEE P802.11, (Sep. 1990), Lucent Technologies, Tutorial on 802.11 to 802, doc.: IEEE P802.11-96/49A Rev.1 to 49E, 70 pages, Mar. 1996.

© 1999 Microsoft Corporation, Microsoft Windows 2000 Server, Operating System, "Virtual Private Networking in Windows 2000: An Overview," White Paper, 24 pages.

C. Perkins, Editor, Network Working Group, Request for Comments: 2002, Category: Standards Track, "IP Mobility Support," IBM, [www.ietf.org/rfc/rfc2002.txt.html](http://www.ietf.org/rfc/rfc2002.txt.html), 32 pages, Oct. 1996.

\* cited by examiner



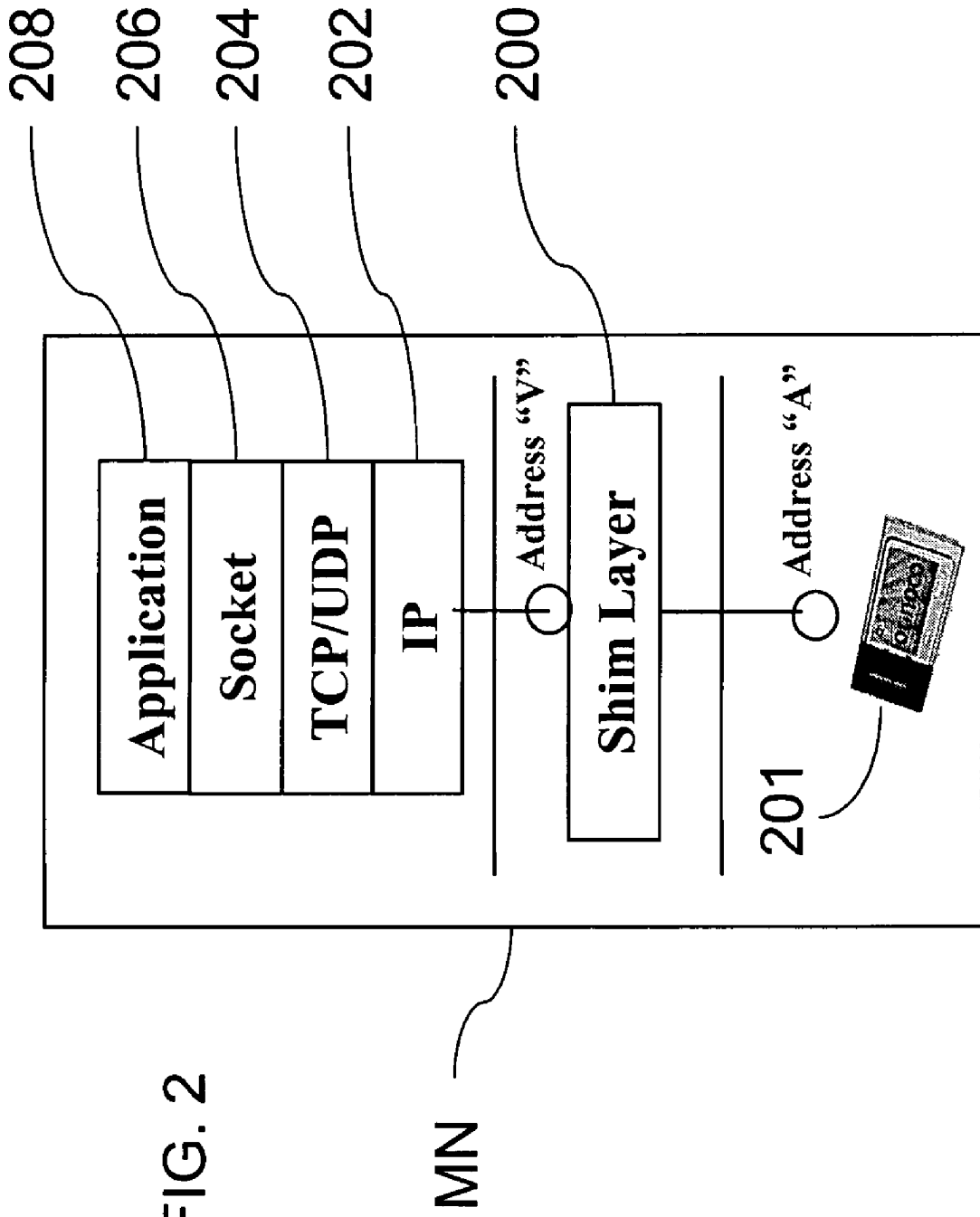

FIG. 2

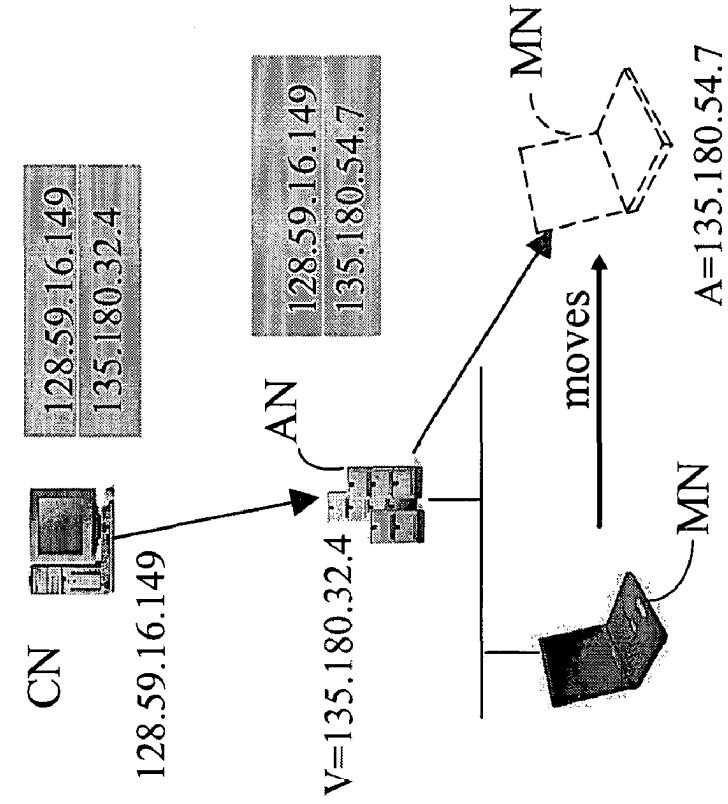

FIG. 3A

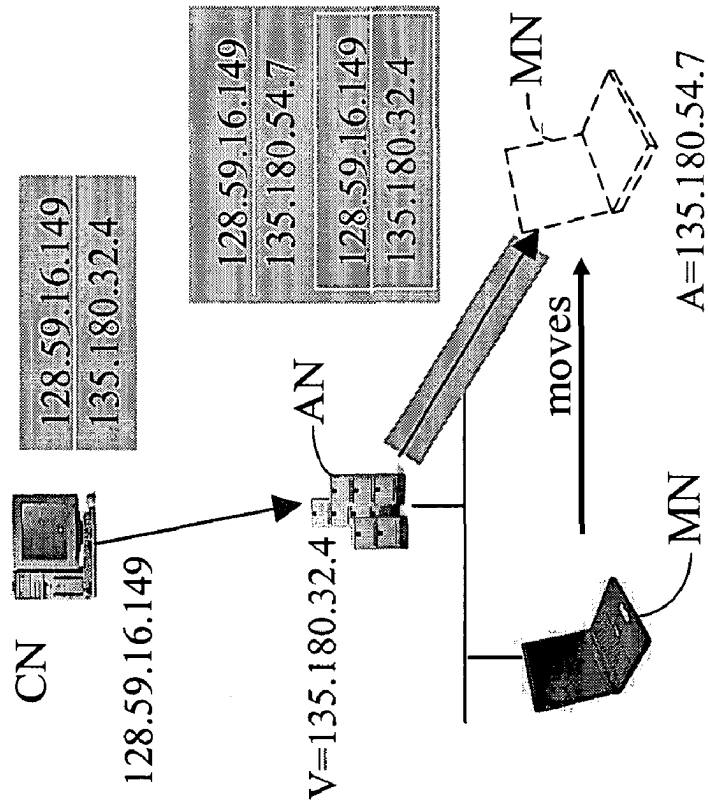
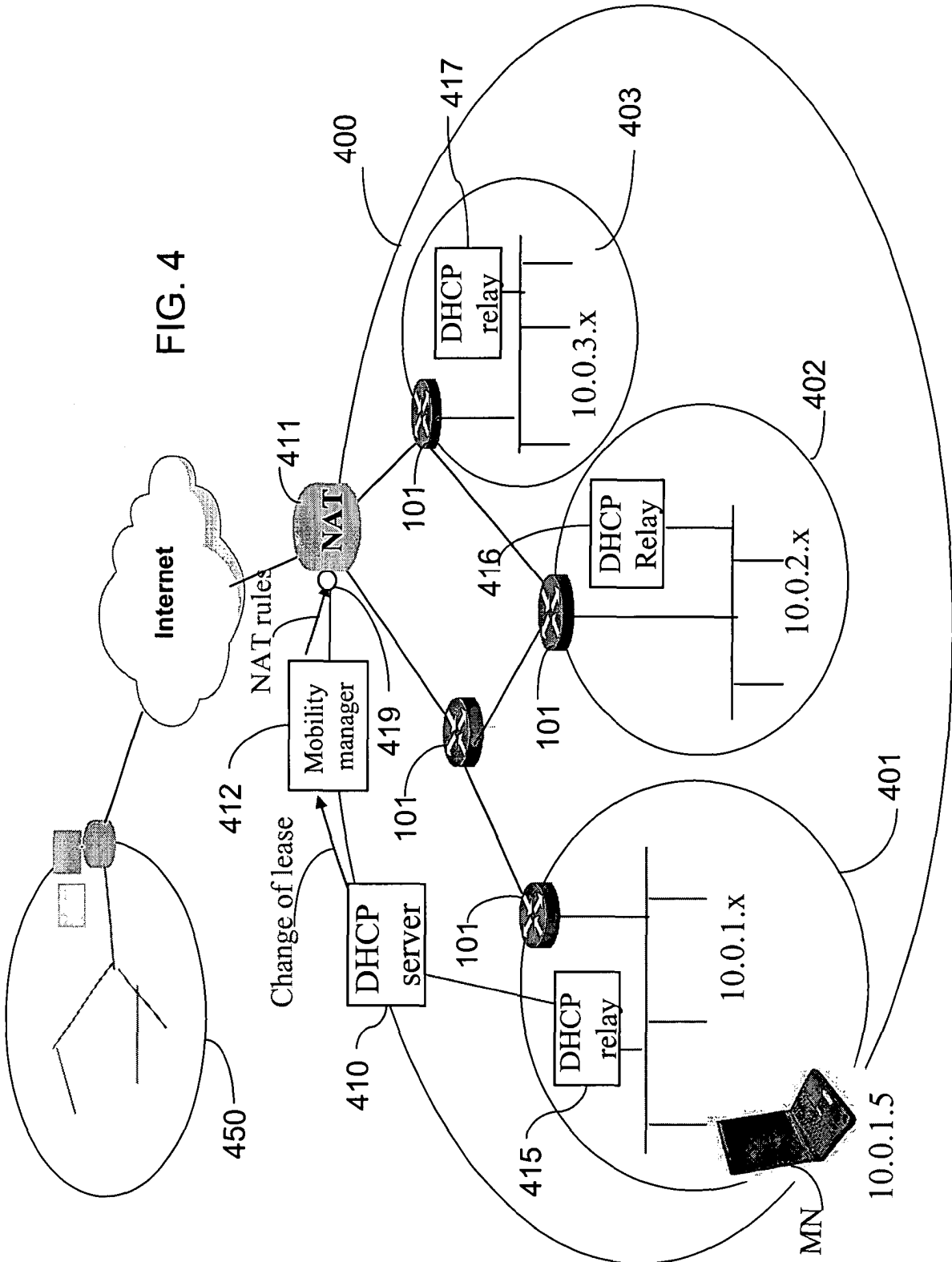

FIG. 3B

FIG. 4



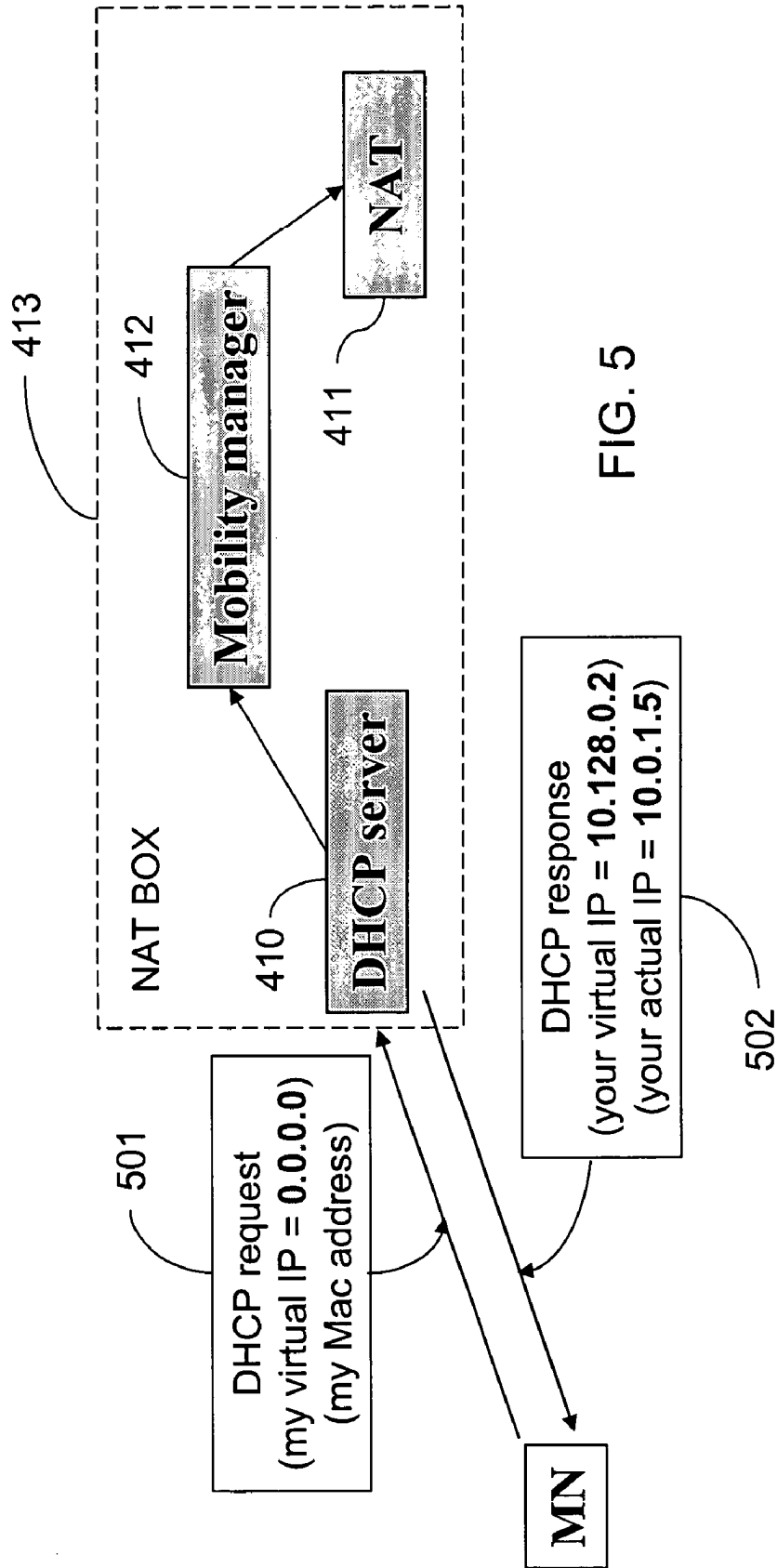

FIG. 5

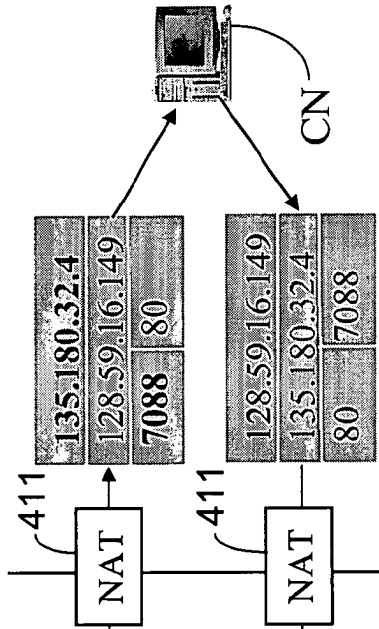

FIG. 6A

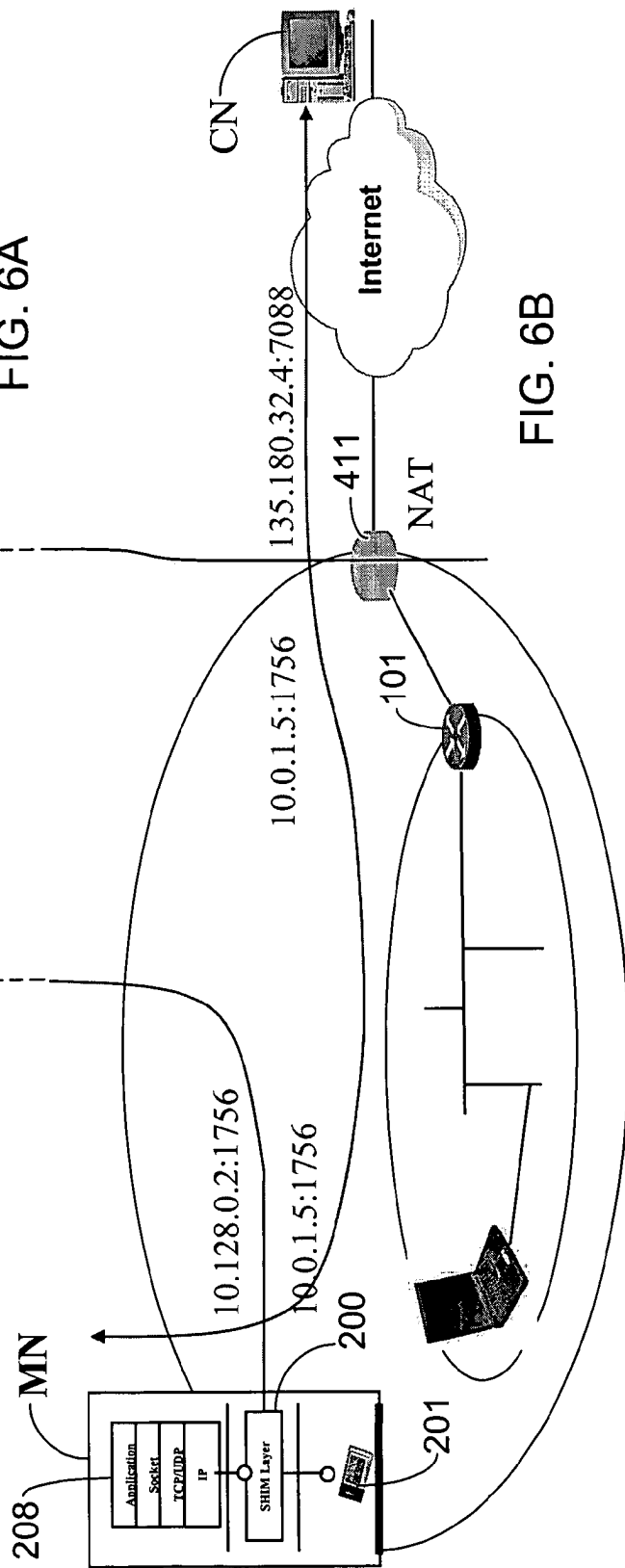

FIG. 6B

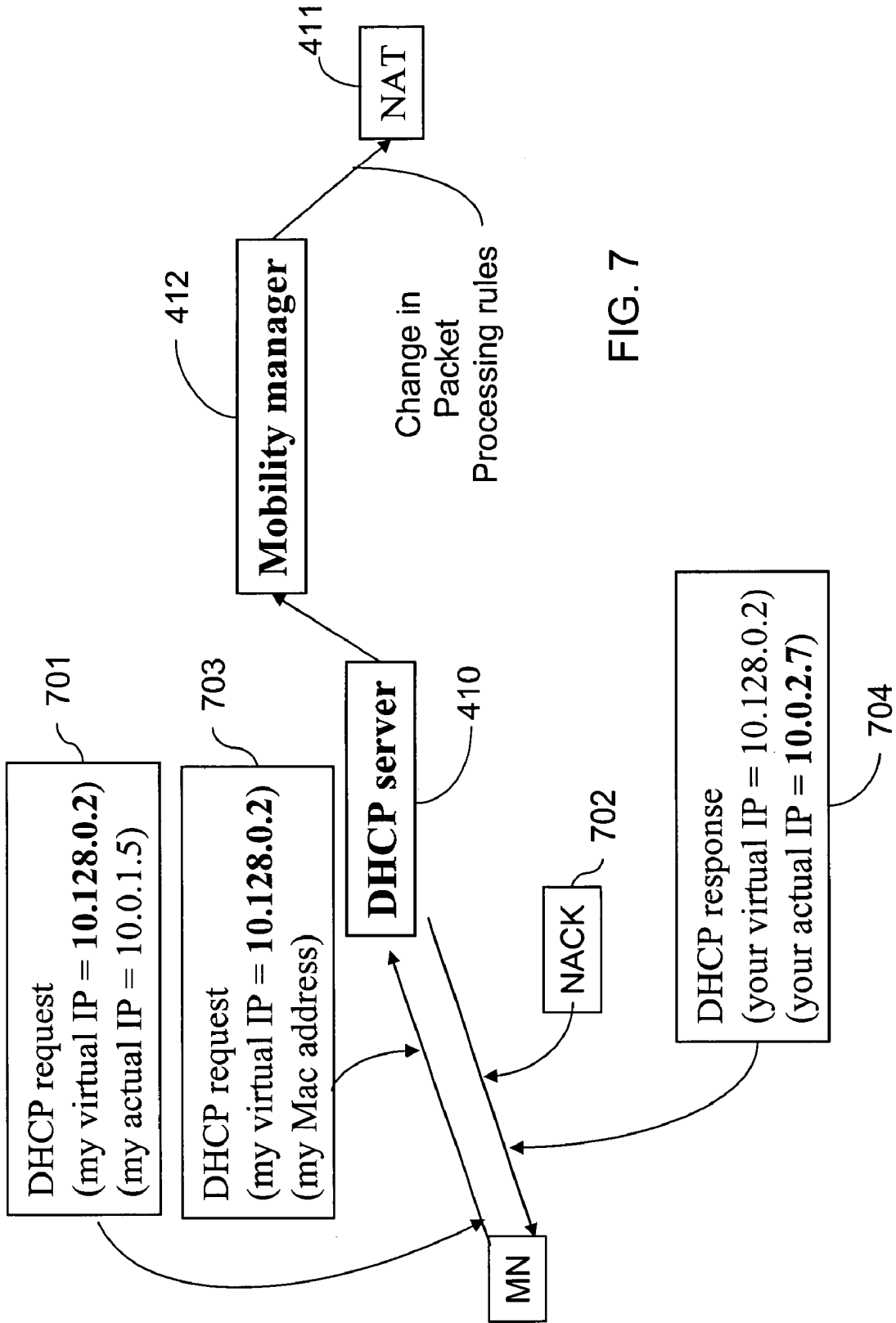

FIG. 7

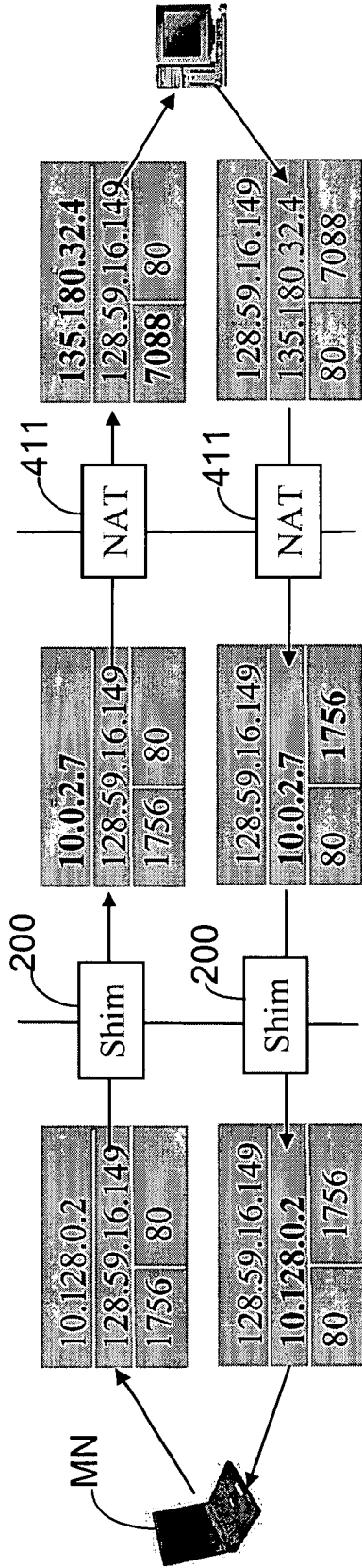

FIG. 8A

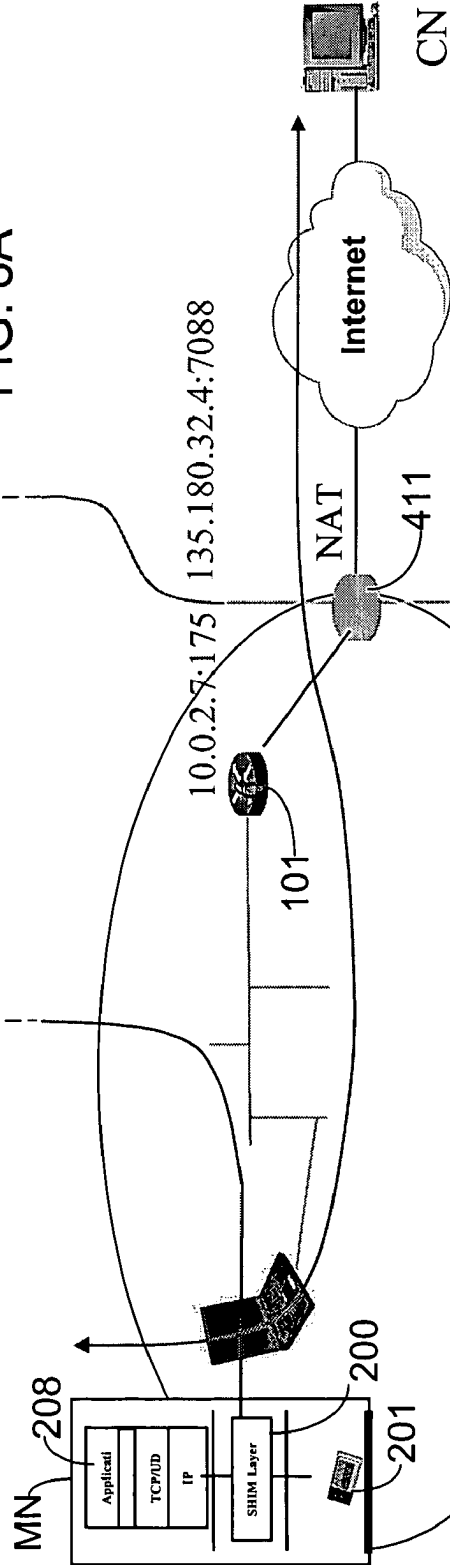
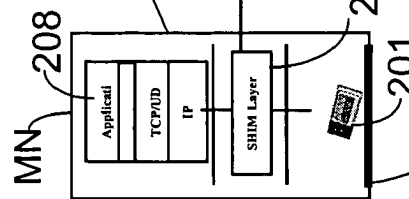

FIG. 8B



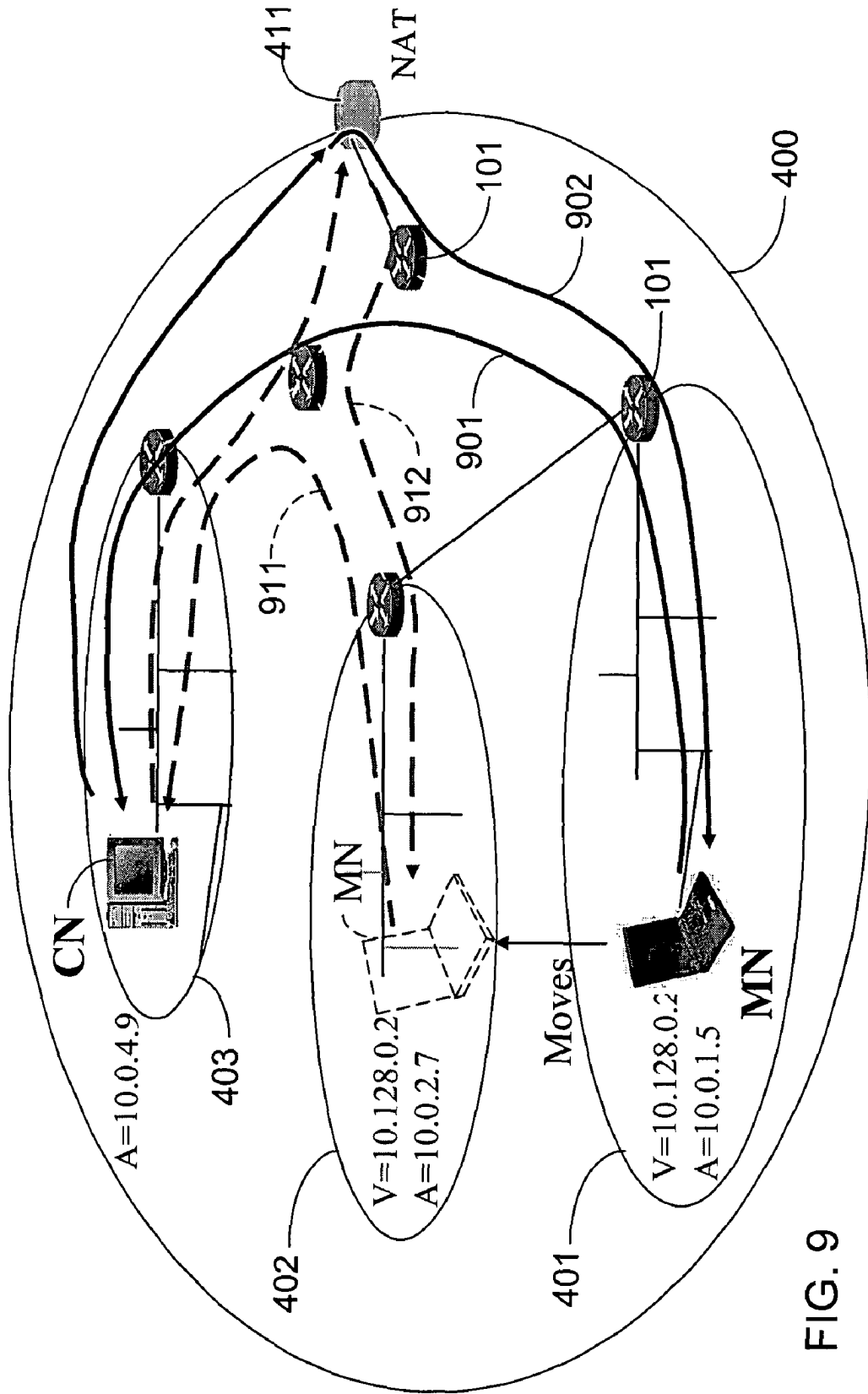

FIG. 9

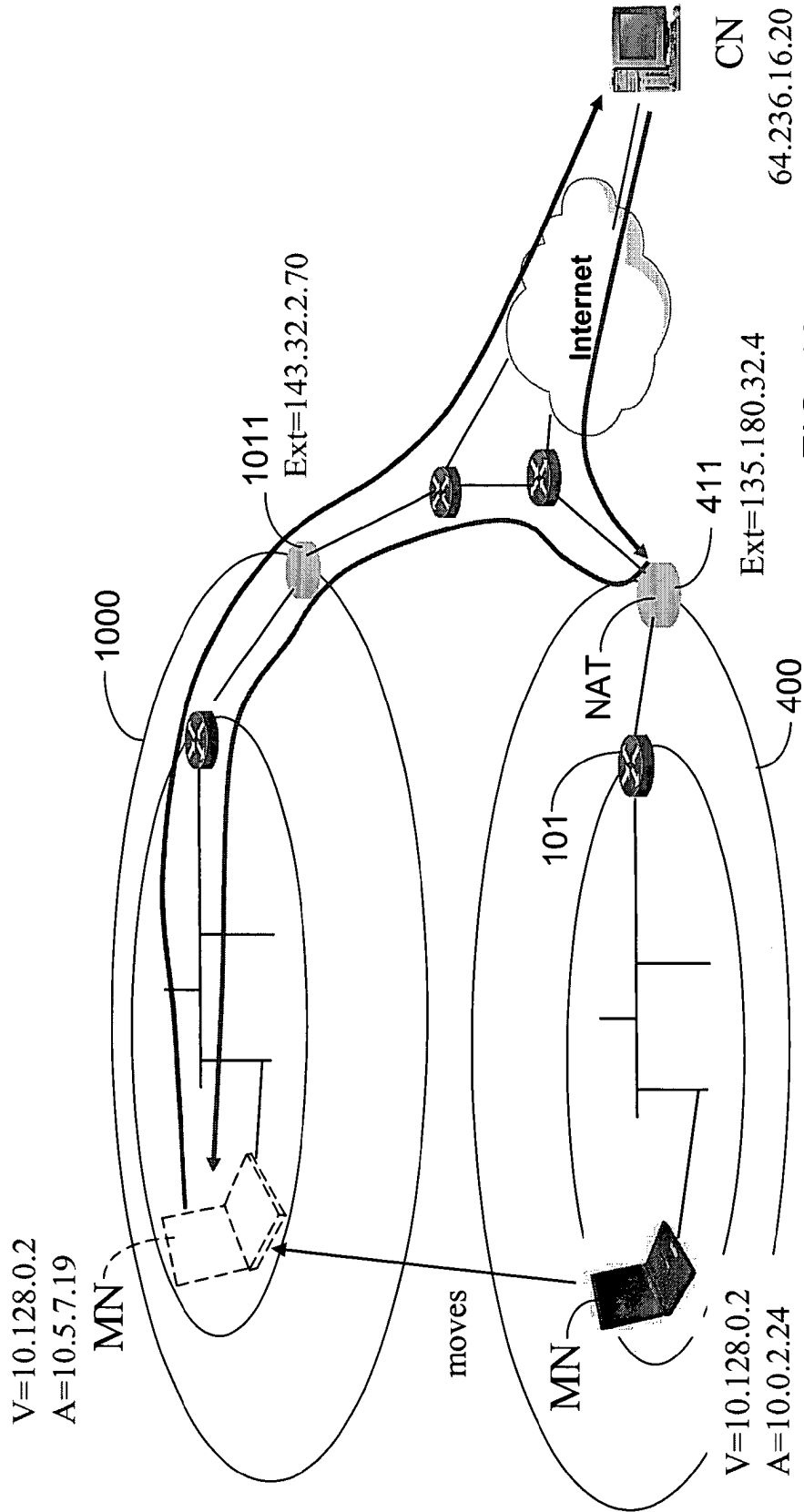

FIG. 10

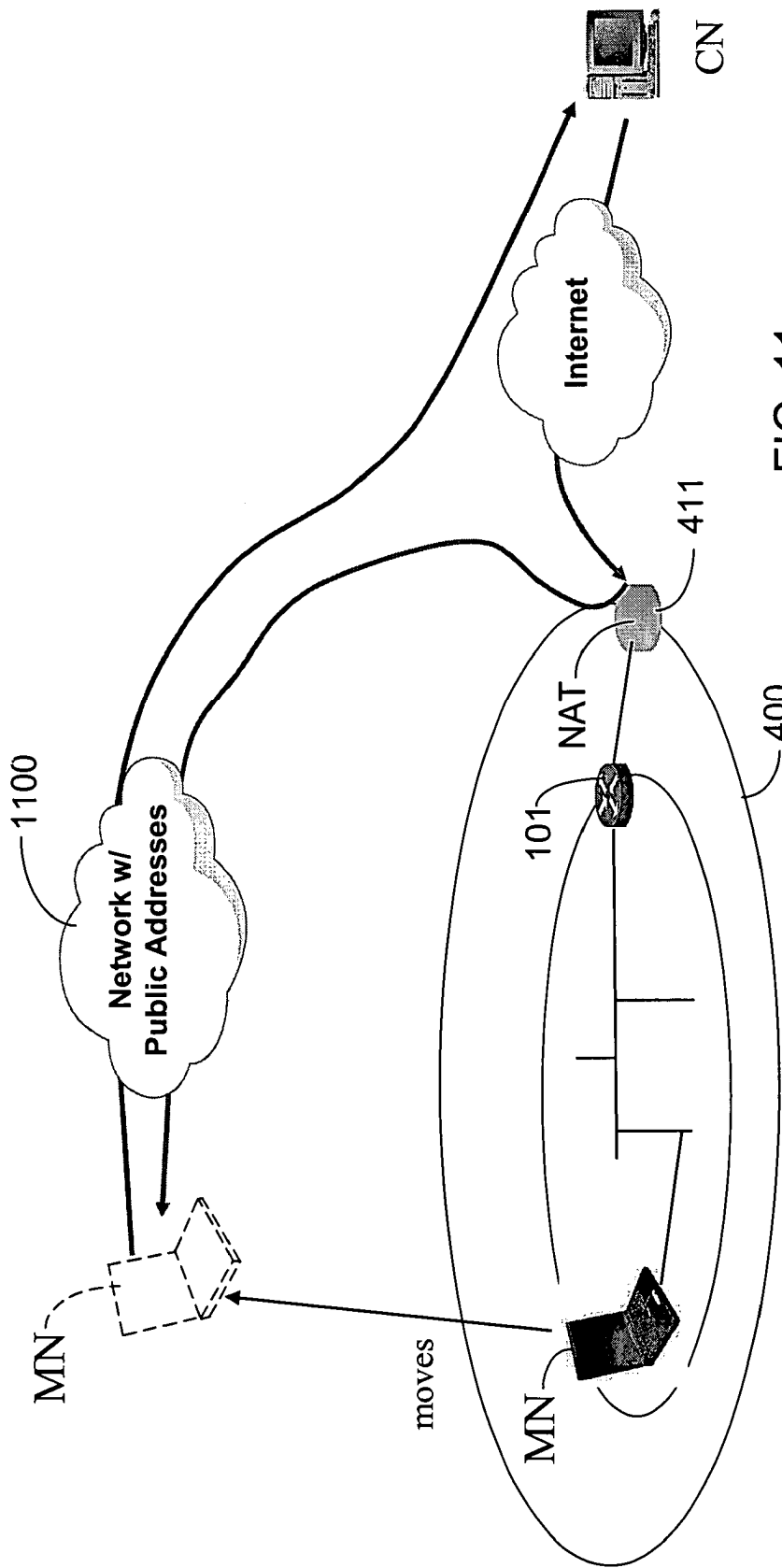

FIG. 11

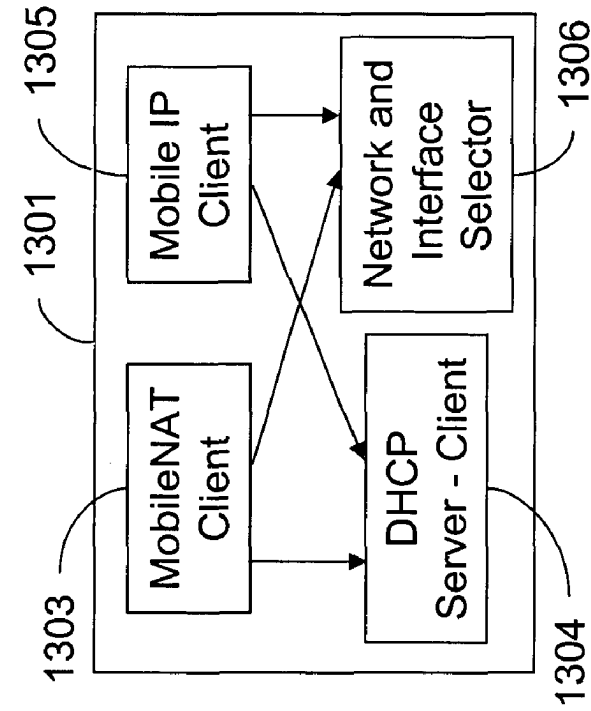

FIG. 13

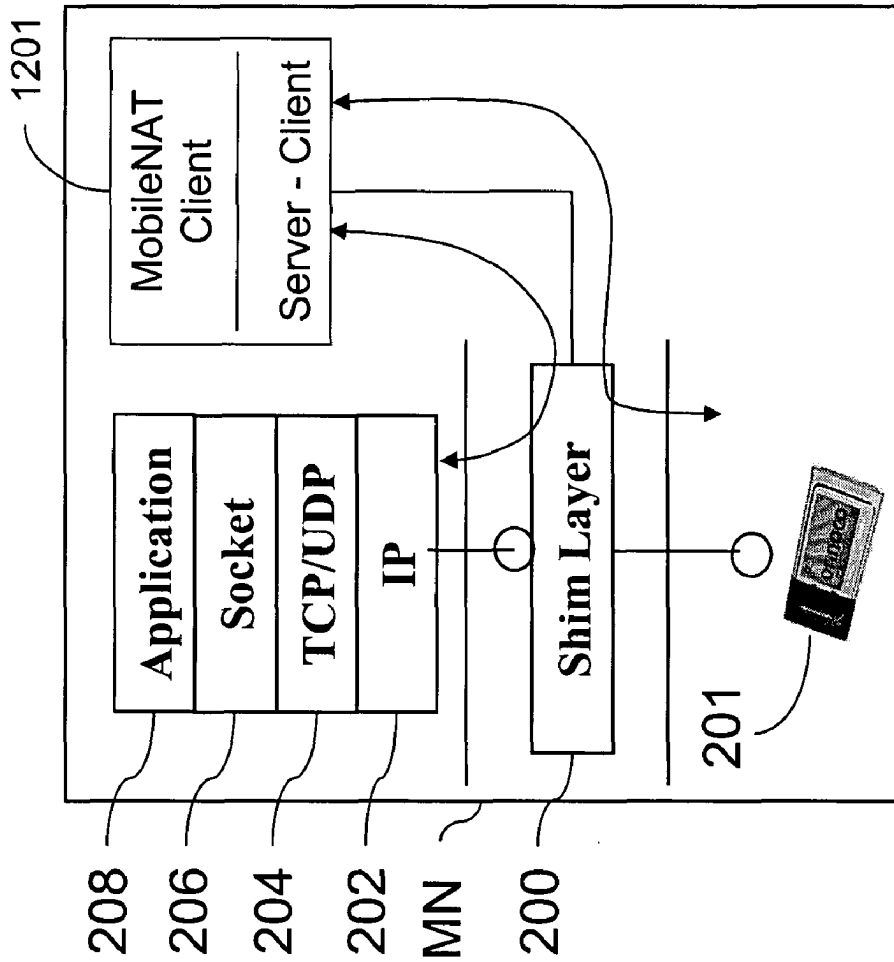

FIG. 12

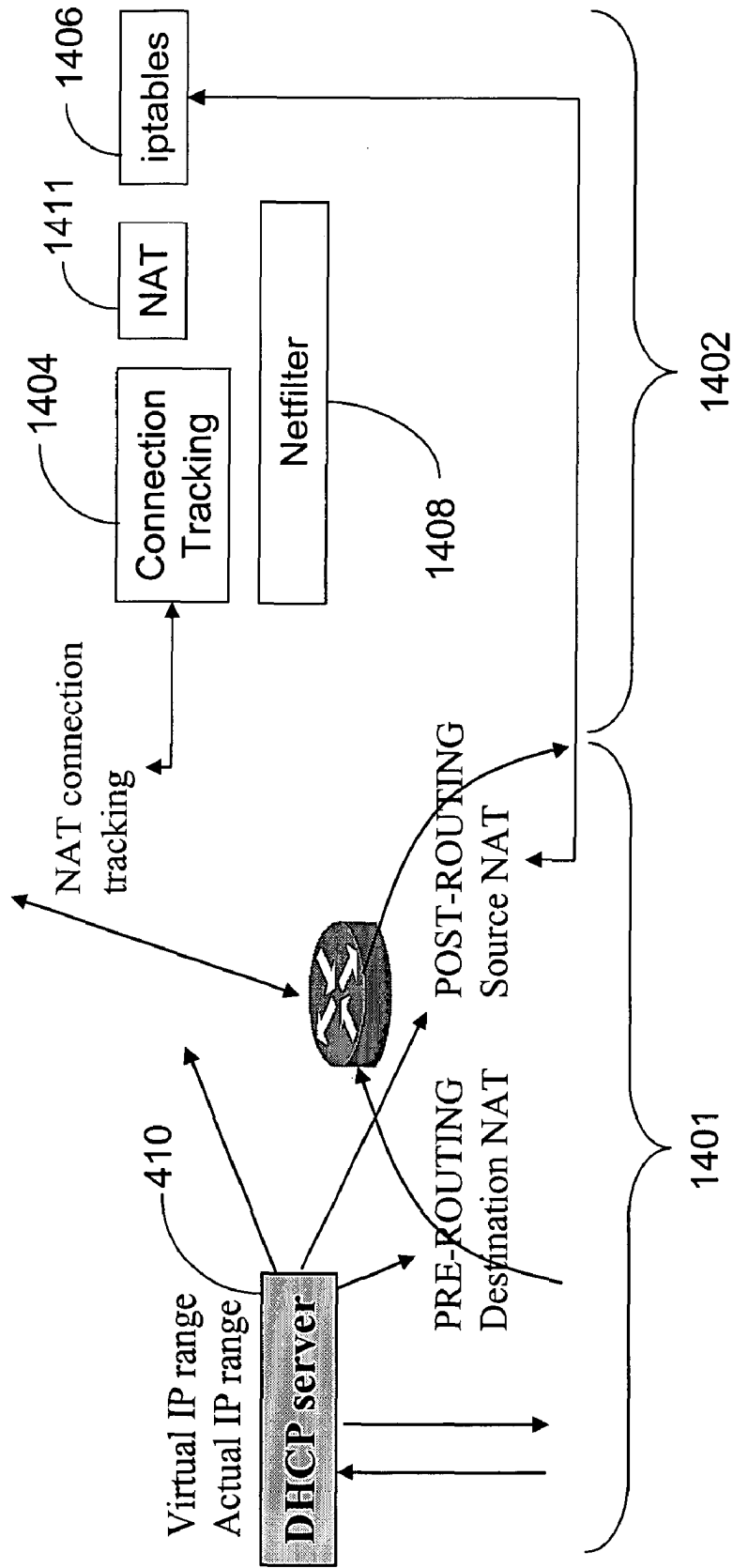
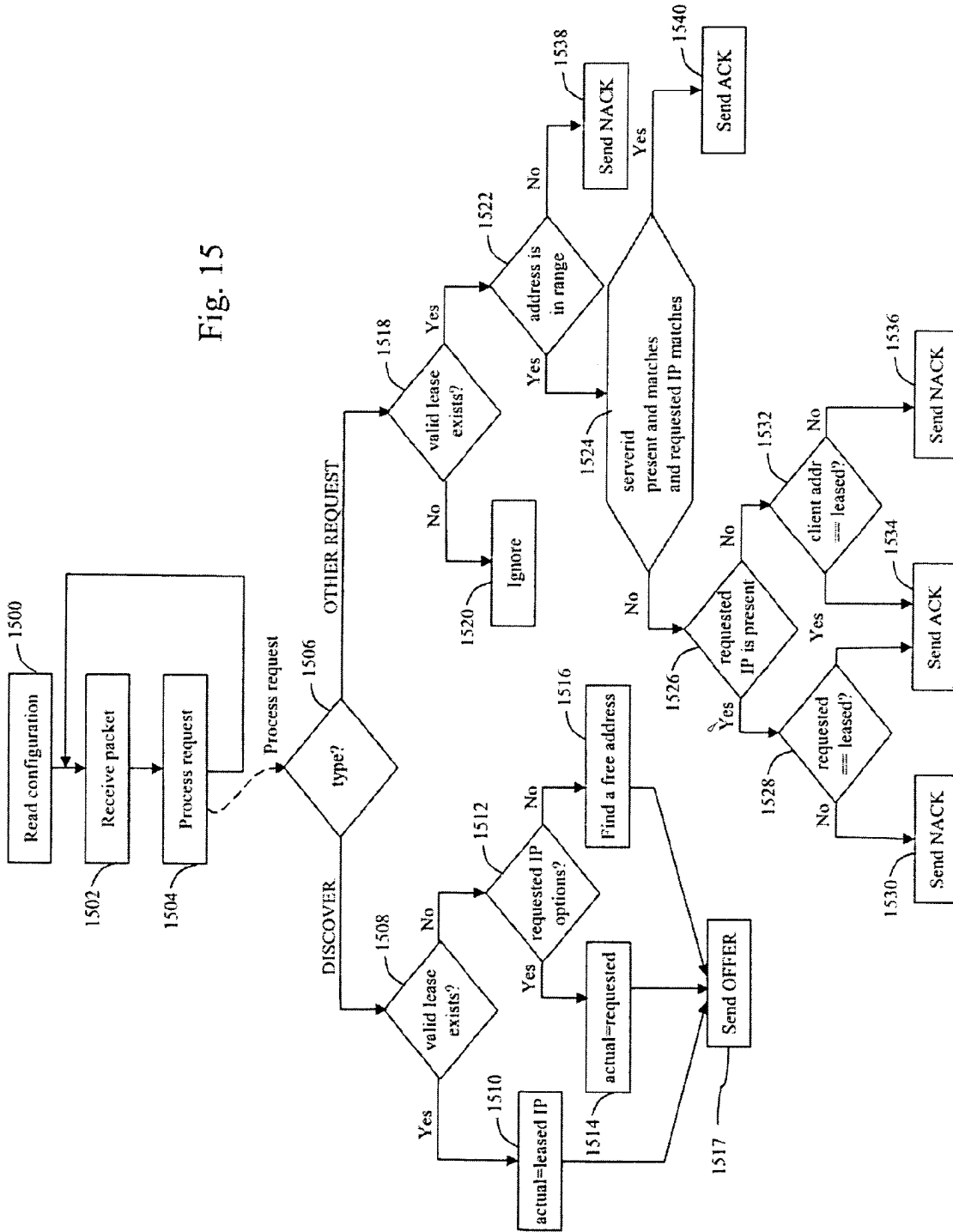

FIG. 14

Fig. 15



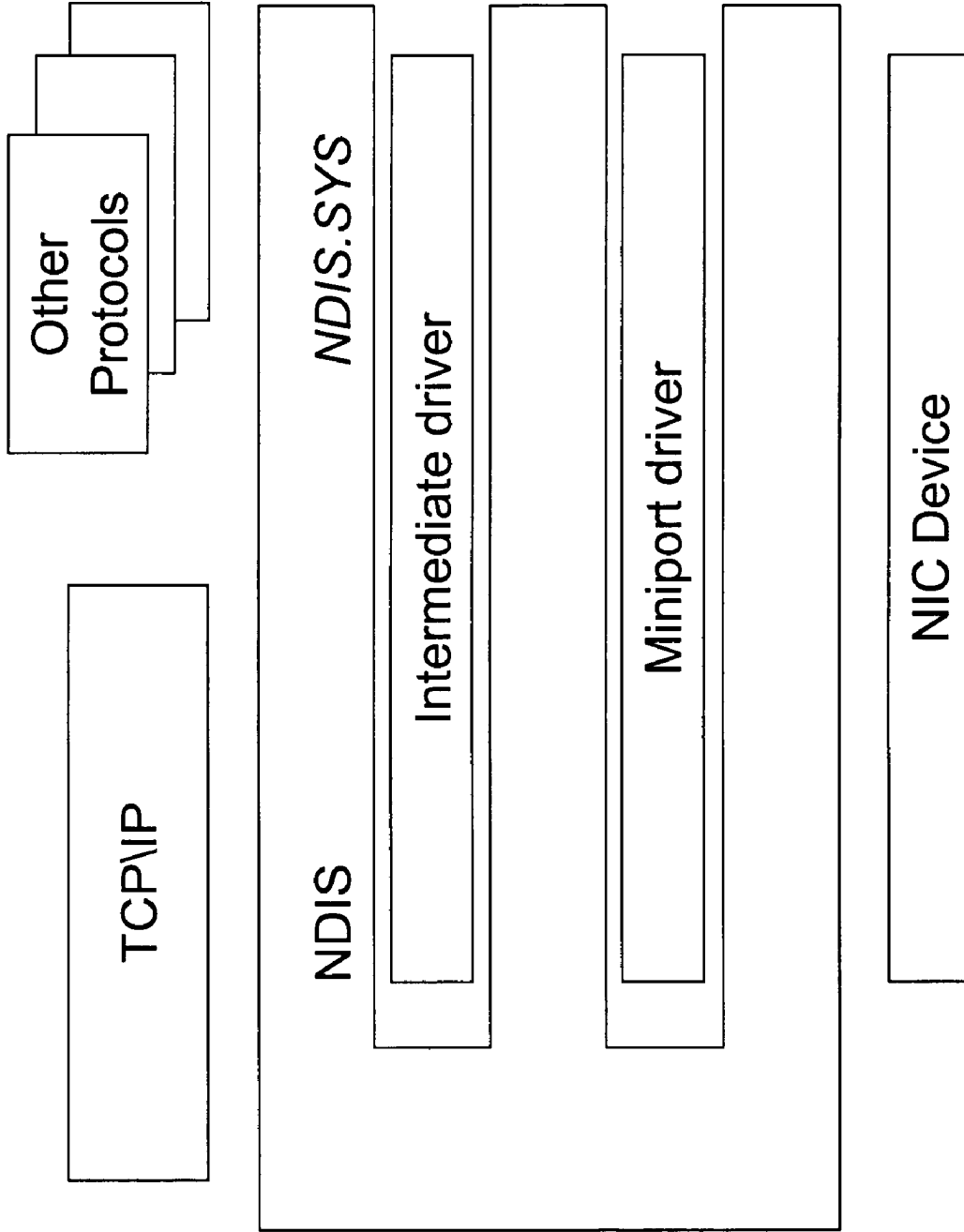

FIG. 16

1

## METHOD AND SYSTEM FOR MOBILITY ACROSS HETEROGENEOUS ADDRESS SPACES

### FIELD OF THE INVENTION

The present invention relates to mobile communications.

### BACKGROUND

Current trends indicate that the Internet address space will be strained further as the deployment of new wireless access networks (e.g.: CDMA2000, 802.11) enables diverse and potentially mobile end-systems such as telemetry devices, sensors, personal digital assistants, (PDAs), laptops to be connected to the Internet. In the past, Network Address Translation (NAT) devices have been widely used to combat the problem of exhaustion of IP address space. Given that widespread deployment of Internet Protocol version 6 (IPv6) networks is still not on the horizon, NAT will continue to be an attractive solution that offers added benefits such as frequent changes in addressing plans and easy support for large public networks without exhausting IP addresses.

Consider a heterogeneous network including a plurality of different service provider domains. These may include: two NATed IP networks with private address space and 802.11 infrastructure, a 3G network with private address space and a public address space campus network. Consider a mobile node (MN) connected to a public host corresponding node (CN) using transport control protocol/internet protocol (TCP/IP). The connection should be preserved when the MN moves from one access point to another, and from one network to another. However, any of the following scenarios can occur:

1. When the MN moves to a new 802.11 access point (AP) in the same subnet, the IP address of MN remains the same. However, the MN needs to detect that the signal strength from the older AP has reduced, and signal strength from the new AP has increased. The MN disassociates with the old AP and re-authenticates with the new AP.

2. When the MN moves from a first subnet A to a second subnet B, the routable IP address of MN changes. It acquires a new IP address using dynamic host configuration protocol (DHCP). However, this breaks the existing TCP connection.

3. When the MN moves from one NAT domain to another, the IP address space, hence the mobile node's IP address, may change. The CN still sends the packets in the connection to the old NAT.

4. An MN with both 802.11 and 3G wireless interfaces may move from an 802.11 network to a 3G network and still wish to preserve the existing connections.

5. When the MN moves from a private address space to a public address space it acquires a new global public address. The private address is no longer valid in this public network.

### SUMMARY OF THE INVENTION

A method for addressing a mobile node includes identifying a host at a level above a network level using an invariant virtual internet protocol (IP) address of the host, identifying the host at a network interface level using a routable actual IP address of the host, and changing the actual IP address of the host without varying the virtual IP address of the host as the mobile node moves intra-domain or interdomain.

A mobile node includes a processor, a network interface, and a storage device having computer program code therein for execution by the processor. The computer program code includes a network layer for transmitting and receiving pack-

2

ets, and an intermediate driver that transmits packets to the network layer and receives packets from the network layer using a virtual internet protocol (IP) address to identify the mobile node. The intermediate driver transmits packets to the network interface and receives packets from the network interface using a routable actual IP address to identify the mobile node. The intermediate driver permits the actual IP address to change when the mobile node moves intra-domain or inter-domain without a corresponding change in the virtual IP address.

A dynamic host configuration protocol (DHCP) server receives a DHCP request from a mobile node. The server assigns a routable actual IP address to the mobile node. The server also assigns a virtual IP address to the mobile node, where the virtual IP address does not change when the mobile node moves intra-domain. The server transmits a message to the mobile node containing the actual IP address and the virtual IP address.

A network address translation (NAT) device receives a plurality of packets identifying a virtual IP address of a mobile node coupled to the NAT device as a destination. The NAT device identifies an actual IP address of the mobile node based on the virtual IP address. The NAT device is capable of associating a first actual IP address with the mobile node while the mobile node is located in a first subnet. The NAT device associates a second actual IP address of the mobile node with the same virtual IP address when the NAT device is notified of mobility of the mobile node. The NAT device routes the packets to the mobile node using the first IP address when the mobile node is in the first subnet and the second IP address when the mobile node is in the second subnet.

### BRIEF DESCRIPTION OF THE DRAWINGS

FIG. 1 shows an exemplary mobile communications system using virtual and actual IP addresses.

FIG. 2 shows the software architecture of the mobile node of FIG. 1.

FIGS. 3A and 3B show two alternative techniques for forwarding packets to the mobile node of FIG. 1 after a mobility event that changes the actual IP address.

FIG. 4 shows the components of the NAT domain of FIG. 1.

FIG. 5 shows a DHCP protocol event when the mobile node in the system of FIG. 1 boots.

FIGS. 6A and 6B show the example of address translation that takes place in the mobile node of FIG. 2.

FIG. 7 shows the DHCP protocol messages used when the mobile node moves from a first subnet to a second subnet.

FIGS. 8A and 8B show the address translation that takes place in the mobile node of FIG. 2 after the mobile node moves to the second subnet.

FIG. 9 shows intra-domain sessions continuing after the mobile node moves to the second subnet.

FIG. 10 shows a sessions with a public domain corresponding node continuing after the mobile node moves to a second NAT domain.

FIG. 11 shows a sessions with a public domain corresponding node continuing after the mobile node moves to a network with a public address space.

FIG. 12 shows an exemplary implementation of the mobile node of FIG. 1.

FIG. 13 shows a variation of the client of FIG. 12.

FIG. 14 shows an exemplary implementation of the DHCP server and NAT.

FIG. 15 is a flow chart diagram of the DHCP server processing.

FIG. 16 is a diagram of an exemplary driver architecture.

#### DETAILED DESCRIPTION

##### DHCP

The exemplary DHCP protocol extends the standard DHCP protocol to include virtual addresses. DHCP is a client-server protocol used for passing configuration information (e.g., IP address) to hosts on a TCP/IP network. It allows automatic allocation of reusable network addresses. The host acts as a DHCP client and discovers the DHCP server in the network by broadcasting a DISCOVER message to the broadcast IP address, 255.255.255.255. The DHCP server in the same network sends an OFFER message to the client indicating that the client can contact this server for further information. The client then REQUESTs the DHCP configuration parameters from the server. The server sends an ACK message to the client indicating the configuration information, including the IP address and the lease time until which the IP address and other configuration parameters will be valid. The client should renew the lease before it expires, by sending another REQUEST to the server. In one example, a node in the same network as the DHCP server (S), e.g., node A, obtains the IP address from S directly, whereas a node B from a different network than S uses a DHCP relay agent (R). The relay agent receives the client broadcast request from B and forwards it to the server S using unicast. The DHCP server S knows the subnet of the client from the relay-agent address in the request. The client IP address is allocated based on the subnet in which the relay agent resides.

##### Network Address Translation

Network address translation (NAT) is a technique for translating one set of IP addresses known in one network to another set of IP addresses known in another. Typically, an organization maps its local inside private addresses to one or more global external public IP addresses. There are pre-defined private IP address spaces, e.g., 10.0.0.0 to 10.255.255.255 is one such range. These IP addresses do not have any global routing significance in the public internet. The source IP address in the outgoing IP packets from hosts with such an address needs to be translated from private to public, and the destination IP address in the incoming packets from public to private. NAT conserves the global IP address space by providing independent islands of private IP address networks. Usually the mapping is established when a new session (e.g., a TCP connection) is established from a node in the private network to a node in the public network. The mapping exists as long as the session is active.

Network address and port translation (NAPT) allows use of the same external public IP address for more than one internal private node by using TCP/user datagram protocol (TCP/UDP) port number for multiplexing multiple sessions. Some MobileNAT embodiments use NAPT in the architecture.

For example, when a host A, with private address 10.0.1.23, sends a TCP SYN connection establishment packet to an external node B with public address 128.59.16.149, the packet is intercepted by the NAT router (10.0.0.1). This NAT box with external IP 135.180.132.24, creates a mapping from the private address 10.0.1.23 and port 1987 to its external IP address 135.180.132.24 and port 1734. The packet is forwarded to node B, as if it was originated from the NAT box, by changing the source IP and port to 135.180.132.24 and 1734 respectively. The NAT intercepts incoming packets having a destination address 135.180.132.24 and port 1734, and changes the destination to

10.0.1.23 and the port to 1987. Node A thinks that it is connected to node B's IP, whereas node B thinks that it is connected to NAT's IP.

NATs are also useful in connecting the IPv6 islands with the core IPv4 Internet.

##### Midcom

NAT devices break application level protocols (e.g., Real Time Streaming Protocol (RTSP) and File Transport Protocol (FTP)) that use the host and port information in the application payload for signaling. For example, the RTSP client in private address space may use RTSP messages to ask the server in the public address space to stream the video to 10.0.1.23. However, this IP address is not visible for the public address node B. This is achieved using application level gateways on the NAT box, that can modify the application specific signaling messages for FTP or RTSP.

Exemplary embodiments can also use Midcom. IETF's Midcom (Middle-box communication) framework decomposes such middle-boxes like NAT and firewalls into the application independent (translation and filtering) and application dependent (policy decision and application specific message intercepting) functions. The router can just implement the application independent filtering and translation, that is in turn controlled by an application level gateway, either co-located or external, in conjunction with appropriate security (authentication and authorization) framework.

This description of the exemplary embodiments is intended to be read in connection with the accompanying drawings, which are to be considered part of the entire written description.

The embodiments described herein address the problem of mobility across address spaces delineated by NAT devices. These embodiments provide seamless mobility for devices such as laptops, PDAs and sensors with client initiated sessions from the private address space to the public address space. The general architecture is referred to below as, "MobileNAT," because address translation may occur in the mobile node and the NAT device. An exemplary MobileNAT system includes the following features:

1. Use of two IP addresses: an invariant "virtual IP address" for host identification at the application layer and an actual routable address at the network layer that changes when the mobile node moves. Because virtual address from a private address space can be used without any global routing significance, such virtual addresses do not deplete the IP address resource.

2. DHCP is used to distribute the virtual and actual IP addresses. A DHCP extension provides virtual IP address and other MobileNAT specific parameters.

3. A new signaling element called the Mobility Manager (MM) may be included. In some embodiments, an MM uses the Middle-box Communication (Midcom) framework to signal to the NATs the changes in packet processing rules in the event of node movement.

In some embodiments, MobileNAT can co-exist with Mobile IP functions and also, eliminate several Mobile IP drawbacks. In particular, overheads such as need for a Home Agent and Home address and use of UDP-in-IP tunnels with NATed domains can be eliminated in MobileNAT systems. Also, MobileNAT does not require any modifications to the access networks and therefore can be used to provide seamless mobility across heterogeneous wireline and wireless networks.

##### Architecture of MobileNAT

Different domains may use different access mechanisms; for example, one domain may use 802.11 wireless LANs whereas other domain may use 3G wide area wireless access.

## 5

Each NATed domain can be a layer-2 (e.g. switched ethernet) or layer-3 (e.g. IP) routed network. If it is a layer-3 IP routed domain, then it includes several layer-2 subnets that are interconnected by IP routers. A Mobile Node (MN) in such a case can experience three kinds of mobility: (1) layer-2 mobility within the same subnet, (2) layer-3 mobility across subnets, and (3) layer-3 mobility across adjacent domains. A mobile node (MN) may have several on-going TCP/IP connections (e.g. web, ftp, telnet, IMAP) and UDP/IP (e.g.: VOIP, RTP) traffic which are collectively referred to as active sessions. In FIG. 1, a mobile node MN communicates with a corresponding node CN by way of an anchor node AN and at least one router 101.

One problem with the IP address is that it is overloaded with two functionalities: (a) host identification by the TCP/UDP layer, and (b) network attachment information for routing. Consider a mobile node (MN) with IP address 135.180.32.4 connected to a corresponding node (CN) with IP address 128.59.16.149 using TCP. Suppose the local and remote port numbers at MN is 1733 and 80, respectively, for this connection. The TCP layer at MN maintains the five-tuple [TCP, 135.180.32.4, 128.59.16.149, 1733, 80] identifying this connection. Similarly the TCP layer in CN identifies the connection as [TCP, 128.59.16.149, 135.180.32.4, 80,1733]. When the MN moves to a new network, and gets a new IP address (e.g., 135.180.34.7), the original TCP connection association breaks and the connection is lost.

One exemplary approach to solve this problem is to use two IP addresses as shown in FIG. 1.

**Virtual IP address:** A fixed and unique IP address is used for host identification that does not change on mobility. The virtual address is used by the TCP/IP stack and higher layer applications.

**Actual IP address:** A routable actual IP address is used for routing purposes, that can change when the host moves.

The fixed virtual IP address corresponds to a fixed (non-mobile) anchor node (AN) in the network. It is assumed that one or more mobility domains each include a homogenous address space such as IPv4 or IPv6 address space, and is delineated from the rest of the network by a respective AN. Using the same example, if the MN's virtual IP is 135.180.32.4, then the TCP association at CN will be [TCP, 128.59.16.149, 135.180.32.4, 80, 1733] (where the five-tuple represents [TCP, virtual IP, CN, source port and destination port]). CN sends the packets to this virtual IP, that is received by the AN and forwarded to the actual IP of the MN. When the MN moves, its actual IP changes. Now the AN can forward the packets to the new actual IP of MN.

Inside the MN, the virtual IP is exposed to the TCP/IP stack and higher layer applications, whereas the actual IP is used for actual routing of the packets.

FIG. 2 is a block diagram of the mobile node MN. A thin layer 200 is provided between the TCP/IP stack 202, 204 and the network interface 201 in the client machine to convert from actual IP to virtual IP and vice-versa. This layer is referred to herein as the shim layer 200. The address translation happens both in the client's shim layer 200 as well as at the anchor node (AN). The AN node therefore is a standard NAT or NAPT device. The packet translation is transparent to the CN, as well as the socket 206 and application 208.

Both the actual and the virtual IP addresses are unique and different. Preferably, the available address range is divided into an actual IP range and a virtual IP range. This division helps in intra-domain sessions as discussed below.

The packets from the AN to the MN can be forwarded in two modes as shown in FIGS. 3A and 3B:

## 6

**Tunneling (FIG. 3A):** In this mode an IP-in-IP tunnel is used to forward the packet from the AN to the MN. The outer IP header contains the tunnel address to the actual IP of the MN, whereas the inner IP header contains the virtual IP of the MN as known by the CN. The reverse traffic does not necessarily need a tunnel from MN to AN. Also, the source IP in the outer tunnel header from AN to MN can be that of the CN or the MN.

**Translation (FIG. 3B):** In this mode the IP header is modified such that the IP addresses are changed from virtual to actual IP of the MN.

The advantage of tunneling is that it involves less processing overhead. The disadvantage is the additional header, hence the increased packet size on the wireless link. For example, in the case of a Internet telephony application using G.729 audio codec with 20 ms packetization interval with 20 bytes payload, 12 bytes Real-Time Transport Protocol (RTP) header, 8 bytes UDP header and 20 bytes of IP header, each IP packet in translate mode will have a size of 60 bytes, whereas the size in tunnel mode is 80 bytes (33% more). In translation mode, one actual IP and one virtual IP address are used per mobile node. In tunnel mode, the same virtual IP address can be shared across multiple nodes, provided a private node does not talk to another private node with the same virtual IP address. The choice between tunnel or translate mode can be made by the client node or can be a domain-wide service provider policy. The chosen mode can be signaled using DHCP. If the network already has a NAT at the AN, then processing overhead in translation mode is not an issues since the existing NAT will already be performing translation.

DHCP may be used to allocate the virtual and actual IP of the MN. In some embodiments, a new DHCP option (shim layer address) is defined to request and allocate the virtual IP address. The MN requests the DHCP server to allocate a new virtual IP address by setting the shim layer address option to 0.0.0.0 in the request. The server allocates a virtual IP address for this MN, and returns it in the shim layer address option in the DHCP response (ACK). If the MN is requesting to renew a previously assigned virtual IP address, the MN puts the old shim layer address in this option. Typically a mobile node acquires a virtual and an actual IP address on initial boot. For subsequent change in the network, the node renews the old virtual IP address, and get a new actual IP address in each network.

Although most of the discussion below uses both actual and virtual IP addresses from the private address space, this is not a requirement. A simple translation scheme will work even if both the IP addresses are chosen from the public IP address space as long as the packets go through an intermediate NAT device. This can be relevant in the case of communication between nodes in IPv4 Internet and IPv6 NAT domains. Use of a public IP address as virtual or actual IP means that the address should be allocated from the external addresses available with the NAT device. This allows the external public node to send the packets to that address and still allows the NAT device to intercept and modify the packets. The choice of public virtual address and private actual address is useful for hosting services like web server from the private address space.

**Mobility Manager**

Consider a MN in a private address space connected to a CN in the public address space via a NAT device at the address space boundary. When the MN moves, and gets a new actual IP address, the mapping (packet processing rule) from the virtual IP to old actual IP should now be changed to a mapping from the same virtual IP to the new actual IP for the MN at the NAT for the existing connection.

Some embodiments include a new network component called mobility manager (MM) **412** for the NAT domain as shown in FIG. 4. A NAT domain **400** includes a plurality of subnets **401-403**, each served by a respective DHCP relay **415-417**. The NAT **411** serves as the boundary of the NAT domain **400**. In some embodiments, every NAT domain **400**, **450** has a MM **412**, NAT **411** and a DHCP server **410**. These three components may be included in a single physical box **413** (as shown in FIG. 5), or they may be implemented in three separate hardware and/or software components, as shown in FIG. 4. The MM **412** informs the NAT device **411** using the Midcom (Middle-box communication) protocol to change the packet processing rule for the existing connection. A Midcom agent **419** (shown as a small circle in FIG. 4) runs on the NAT box **411**, receives the requests and updates the packet processing rules. The MM **412** receives the change in IP address indication from the DHCP server **410**. The DHCP server **410** knows the actual and virtual IP address of the MN **412** and informs the MM everytime the MN moves to a new actual IP location. In these embodiments, every mobile node knows the IP address of the MM in its domain, as this IP address is sent in a new DHCP options in the response from the DHCP server.

#### Dynamic Home Agent

Some features of MobileNAT can be considered analogous to a Mobile IP system in co-located mode that is reconfigured with the foreign agent (FA) located in the shim-layer (i.e., between the network layer software and the network interface card) and the home agent (HA) located in the NAT. However, MobileNAT has other advantages. For example, using MobileNAT, the MN does not need a fixed home agent, and it can dynamically detect and use a NAT as a home agent. Thus, the NAT can be viewed as a per-connection HA as opposed to the per-host HA. The MN can use one NAT as a HA for one connection, and another NAT as HA for another connection if the node moves from one NAT domain to another as discussed below. When the node moves to a new NAT domain, it uses the new NAT as the home agent for the new connections.

FIG. 5 shows the MN startup process. When the MN is started (initial boot), it sends a DHCP request (DISCOVER) **501** to the DHCP server **410** indicating that MN does not have a virtual IP address (In the request, the shim layer address option contains 0.0.0.0, and the media access control (MAC) layer address of MN is included) as shown in FIG. 5. The DHCP server **410** allocates a virtual IP of 10.128.0.2 from the free pool of virtual IP range (10.128.0.1-10.255.255.254), and an actual IP of 10.0.1.5 from the free pool of addresses in the actual IP range within this subnet (10.0.1.4-10.0.1.254). The server **410** sends MN a DHCP response **502** that includes virtual and actual IP addresses. The DHCP server **410** also informs the MM **412** to update the NAT processing rules of NAT **411**. FIG. 5 also shows that the DHCP server **410**, NAT **411** and MM **412** may all be contained within a single physical box, and may be implemented as separate processes that share processing, memory and storage hardware resources.

FIGS. 6A and 6B shows the address translation process for this example. FIG. 6A shows the source and destination addresses as seen by various nodes in the system. FIG. 6B shows the hardware devices and software processes corresponding to the nodes in FIG. 6A. When the application (e.g., a telnet client) **208** in MN sends a TCP message to the CN with EP 128.59.16.149, the TCP/IP stack uses the virtual IP of 10.128.0.2 as the source IP as shown in FIG. 6A. The shim layer **200** translates the source IP from virtual IP address (10.128.0.2) to actual IP address of 10.0.1.5 and sends it to the network interface driver **201**. The packet reaches the NAT device **411**, where it picks up a new external (public) IP

address of 135.180.32.4 and port 7088, from its range of external IP and port, for this new connection. The packet processing rule at the NAT **411** maps the tuple [TCP, 10.0.1.5, 128.59.16.149, 1756, 80] to [TCP, 135.180.32.4, 128.59.16.149, 7088, 80] in the outgoing direction and the reverse in the incoming direction. Similarly the destination IP in packets from CN to MN is changed from 135.180.32.4 to 10.0.1.5 and port from 7088 to 1756 at the NAT device **411**. The shim layer **200** in the MN further changes the destination IP from actual IP address 10.0.1.5 to virtual IP address 10.128.0.2 and gives it to the TCP/IP stack **202**, **204**.

FIG. 7 shows the DHCP exchange when the MN moves to a new subnet. MN sends a DHCP REQUEST **701** with shim layer address option containing the old virtual IP of 10.128.0.2 and requested IP of old actual IP 10.0.1.5. Since the DHCP server **410** discovers that the MN's relay is not in the same subnet as 10.0.1.5, but is in the subnet 10.0.2.x, it can not allocate the same actual IP of 10.0.1.5. So the DHCP server sends a NACK **702** to the MN. The MN now sends a DISCOVER message **703** with the shim layer address option containing 10.128.0.2 and no requested IP. Now the DHCP server **410** allocates a new actual IP of 10.0.2.7 in the new subnet, and sends a response **704** to MN. It also informs the MM **412** about the change in the virtual to actual IP mapping so that the MM can change the NAT packet processing rules. All occurrences of old actual IP is changed to the new actual IP in the NAT packet processing tables.

FIGS. 8A and 8B show the various addresses seen by the various nodes after MN has moved to a second subnet. Now the shim layer **200** changes the source IP to the new actual IP of 10.0.2.7 for outgoing packets. The source IP is changed to the same old external IP 135.180.32.4 and port 7088 at the NAT **411**. A close comparison between FIGS. 6A and 8A shows that the only change is in the actual IP address. Since the change in actual IP address from 10.0.1.5 to 10.0.2.7 is visible only in the NAT domain between the shim layer **200** and the NAT **411**, and is transparent to the TCP/IP stack **202**, **204** and the CN, the connections are preserved.

FIG. 9 shows intra-domain sessions when a node MN moves from one subnet **401** to another subnet **402**. For an existing session between the MN (in subnet **401**) and the CN, the NAT **411** applies the source address translation (SNAT) from actual IP to virtual IP, and the destination address translation (DNAT) from virtual IP to actual IP. When the MN sends packets to CN, the packets follow route **901** directly to the CN at IP address 10.0.4.9 without going through the NAT **411**. When the CN sends packets to the MN, to virtual IP 10.128.0.2, the packet follows route **902** to reach the NAT device **411**, which translates the destination from virtual 10.128.0.2 to actual 10.0.1.5. Note that all the virtual IP addresses are routable to the NAT device **411** within the domain.

When the MN moves to a new subnet **402** and gets a new actual IP 10.0.2.7, both the SNAT and DNAT tables are updated to reflect the new actual IP address. The packets from the MN to CN still go directly by route **911**, but packets from CN to the new actual IP 10.0.2.7 of the MN follow route **902**, in which they are forwarded by the NAT **411**.

Although the example shows that the CN is stationary, the scheme works even if CN is also mobile. Consider another mobile node MN2 (not shown) with actual IP address as 10.10.1.2 and virtual IP as 10.128.0.3, talking to first MN (say MN1, not shown). An application on MN1 sends the packet with destination IP 10.128.0.3 and source 10.128.0.2. The shim layer **200** translates the source to actual 10.0.1.5. NAT **411** intercepts the packet, changes the destination address from virtual 10.128.0.3 to actual 10.10.1.2. It also changes the

source address from actual 10.0.1.5 to virtual 10.128.0.2. The packet is forwarded to MN2 with source 10.128.0.2 and destination 10.10.1.2. The shim layer **200** of MN2 further translates the destination from actual 10.10.1.2 to virtual 10.128.0.3. Both the applications on MN1 and MN2 think that the connection is established between the virtual addresses 10.128.0.2 and 10.128.0.3. Now if either MN1 or MN2 moves to a new actual IP address, the packets can still be delivered through NAT **411**, by mapping the virtual IP to actual IP.

In some embodiments, optimization may be performed when both the end-points have MobileNAT implementations, so that the packets can be exchanged directly between the two endpoints instead of going through the NAT **411**.

FIG. **10** shows an exemplary network in which the mobile node MN (with actual IP 10.0.2.24 and virtual IP 10.128.0.2) moves from one NAT domain **400** (with external IP 135.180.32.4) to another NAT domain **1000** (with external IP 143.32.2.70) and acquires a new actual IP address of 10.5.7.19. The TCP connection is with the CN 64.236.16.20 at port 80. Since the CN still thinks that it is connected to the old IP 135.180.32.4, the system signals the old NAT **411** (referred to as Home NAT for the mobile node) to forward the packets to the external IP address of the new NAT **1011** (this is called the Visited NAT). The new NAT **1011** is signaled to forward the packet on this external IP and port to the internal mobile node at its actual IP address. Again, the choice of either tunneling or translation between the two NATs **411** or **1011** is possible. Since the NATs **411**, **1011** are expected to be on high-speed wireline network, the bandwidth overhead of tunneling is not really an issue. However, tunneling reduces the number of external IP addresses needed for this migrated connections, as all connections can share the same IP address.

There is a problem if another node (MN2 not shown) in the new domain **1000** has the same virtual IP address 10.128.0.2 as this mobile node MN. In this case, the mobile node MN will not be able to connect to the other node MN2 with same virtual address unless mobile node MN changes its virtual address (at least for connections in the NAT domain **1000** where MN2 is located).

When the node MN moves to a new NAT domain **1000**, it notifies the new DHCP server (not shown) that its old virtual IP address was 10.128.0.2 and the old mobility manager (MM) **412** associated with old NAT **411** was 135.180.32.4. If the new DHCP server, after authentication, find out that the virtual address 10.128.0.2 is used by another node MN2, then the new DHCP server allocates a new unused virtual address (e.g., 10.128.0.5). The new MM queries the old MM **412** about the existing connections and updates the mapping tables in the home and visited NATs **411** and **1011**, respectively.

The mobile node MN keeps using the old virtual address 10.128.0.2 for the old connections, and uses the new virtual address 10.128.0.5 for the new connections. The node MN sets the new virtual IP address as the more preferred virtual IP address. Unless the MN closes all the old sessions, it can not release the old virtual IP address 10.128.0.2. Until then, MN cannot establish new connection to the other node MN2 in the network with the same virtual IP address 10.128.0.2. However MN can still establish connections to other nodes with different IP addresses using its more preferred new virtual IP address 10.128.0.5. If the node's OS is not capable of assigning two virtual IP addresses to the same interface, the shim layer **200** tries to expose another virtual adaptor with the new virtual IP address 10.128.0.5. If this also fails, then it gives a choice to the user to (1) continue with the old sessions, and not establish new sessions, or (2) close all the existing sessions

and start afresh. When the shim layer **200** detects that all the sessions are closed it automatically removes the old virtual IP mappings and uses the new IP for all purposes. However, this involves additional connection tracking overhead in the shim layer **200**. In some embodiments, to avoid the overhead, the shim layer **200** can always prompt the user to make the decision when to start afresh with the new virtual IP address.

Note that the traffic from the visited NAT **1011** to the CN can be either direct, in which case the visited NAT fakes its source address as that of the home NAT **411**, or it can be through the home NAT **411** (in either tunnel or translate mode).

When the MN moves to a third NAT domain (not shown), the old visited NAT **1011** becomes home NAT for some connections, whereas the old home NAT **411** remains home NAT for the old connections if they are still active. Long lived sessions, while the host moves across multiple NAT domains may result in many visited and home NATs for different connections. Local MMs may enforce a policy as to how long a node can use its NAT as home NAT after moving out of this domain. When the node returns back to the home NAT, the MM detects this and updates the existing connections mappings.

As long as the MN is using the old virtual IP of the Home NAT domain **400**, it must refresh this address with the old DHCP server. Since, the old DHCP server is not accessible from the new NAT domain, the MN signals the mobility manager (MM) which in turn signals the DHCP server.

When the node MN moves to the new NAT domain **1000**, the existing intra-domain sessions can also be preserved by altering the translation tables at the visited and home NATs **1011** and **411**, respectively.

The scenario of a node MN moving from a private NAT domain **400** to a public address space **1100** is similar, as shown in FIG. **11**. In tunnel mode, the operation is analogous to MobileIP with the home agent at the home NAT **411**, and the co-located foreign agent at the mobile node MN. Since there is no visited NAT in public address space **1100**, the shim layer **200** of MN does the translation on a per-connection basis. Moreover, in the absence of a new MM **412**, the shim layer **200** also does additional authentication with the old MM for updating the home NAT tables. To simplify the shim layer implementation, some embodiments do not to support this kind of mobility, and instead terminate existing sessions.

When a node that is already in a public address space (presumably using Mobile IP with a global home address), moves to the NAT domain, that node can use the existing IP-in-UDP tunnel approach. This technique does not use the capabilities of MobileNAT. However, if the node's home agent is co-located with the NAT **411**, then it may choose to switch from the Mobile IP mode to MobileNAT mode.

#### Exemplary Implementation of MobileNAT

This section describes the design and implementation details of an exemplary MobileNAT implementation using Windows XP client and a Linux NAT box. This example supports connection migration of an active TCP telnet session with an external public corresponding node when the internal private mobile node moves from one subnet to another in the same NAT domain.

There are two main components as shown in FIGS. **12-14**:

Client: One exemplary client side implementation shown in FIG. **12** is divided into two parts: the driver layer (called the shim-layer) **200** that sits between the TCP/IP stack **202**, **204** and the network interface **201**, and the application level processing (called mnac client) **1201** that processes application level DHCP client messages and interacts with the shim-layer using ioctl calls.

## 11

A unified mobility client implementation is shown in FIG. 13. The MobileNAT Client 1303 and DHCP server client 1304 are provided, similar to those in FIG. 12. In addition, a Mobile IP client 1304 and a network interface selector 1305 are included.

## Server Side Components

## Linux NAT and Connection Tracking

Server: FIG. 14 shows the server (NAT) side implementation divided into two parts 1401 and 1402. Portion 1401 includes the DHCP server application 410 that allocates the virtual and actual IP addresses and calls the Linux netfilter modules 1408 to change the NAT tables 1406. In portion 1402, the new setsockopt option allows changing the IP address of the existing connections in the Linux connection tracking module 14-4.

The example uses the netfilter 1408, iptables 1406, ip\_conntrack 1404 and ip\_nat modules 1411 in the Red-hat Linux kernel 2.4.18 for NAT functions. The netfilter module 1408 provides a generic framework for any filtering and translation of IP packets for router or host. There are various stages in the routing path where the processing hooks can be applied. In particular, for routers, the pre-routing stage can have destination address translation (DNAT) and the post-routing stage can have the source address translation (SNAT). Moreover, standard NAT functionality of mapping internal private IP and port to external public IP and port is implemented using the NAT masquerade table in the post routing stage for packet going to the external interface. A connection tracking table maintains the ongoing active or pending connections such that, with the mapping specified in one direction, the reverse mapping is automatically established when the connection is established. For instance, when the private node makes a TCP connection to an external public host, the masquerade table picks up an available external IP and port for the connection and creates the connection tracking entry (internal datastructure in the memory). When the reply comes from the public host, the connection tracking entry makes sure that the packet goes to the appropriate internal private node.

The various tables like SNAT, DNAT and MASQUERADE can be specified using the iptables command. The iptables module 1406 (that is a replacement for the old ipchains module) maintains all these tables. The ip\_conntrack 1404 and ip\_nat 1411 modules are hooked into the netfilter framework. For every packet, these modules are invoked. The first packet in a session is processed by the ip\_nat module 1411, that looks up into the various iptables tables 1406, translates the IP address, and creates a connection tracking mapping. All subsequent packets in the session are applied the same address translation.

Iptables can help specify the initial translation mechanism. For example, one can specify to pick a IP in range 135.180.32.1-135.180.32.7 and port 8000-10000 for outgoing connections in the MASQUERADE table. However, the exact IP address and port picked up by the ip\_nat module 1411 for a connection is stored internally in memory by the ip\_conntrack 1404 and ip\_nat 1411 modules. To change the actual IP address in the connection tracking, a new setsockopt option is provided. The iptables command is not sufficient for this purpose. The connection tracking module 1404 maintains a hash-table of all the connections in each direction. The hash table has information about the source/destination IP and port and the protocol. The forward direction structure is linked to the reverse direction. The connection structure also has protocol specific information (port number) and information about other modules like NAT and FTP helper. The hash is

## 12

computed using the source/destination IP/port and protocol. When the actual IP is changed, the hash for the connection changes, hence it is removed from the old slot in the hash-table and moved to the new slot. The same is true for the internal hash tables in the NAT and FTP modules. In one exemplary implementation, the connection tracking module 1404 invokes a call back from the NAT module 1411 when such change in IP address happens.

A new option SO\_REPLACE\_NAT\_IP as shown in the code below. This implementation changes the connection structure for forward and reverse connections in the conntrack module 1404. It also changes the connection hash in ip\_conntrack 1404 and ip\_nat 1411 modules. The implementation resides in the ip\_conntrack module 1404. The ip\_nat module 1411 plugs in a call back in to the ip\_conntrack module 1404, that gets invoked when setsockopt is called. This callback function changes the hash in the ip\_nat module 1411, since those data-structures are not directly accessible from the ip\_conntrack module 1404. Since the ip\_conntrack module 1404 is loaded before the ip\_nat module 1411, this scheme works. Alternatively, one can provide many setsockopt commands, one in each module to update the IP address. In the first scheme, the call back is plugged in from other modules like FTP that maintain their own hash-table with hash consisting of the IP address.

```

#define SO_REPLACE_NAT_IP 80
typedef struct replacenatip
{
    struct in_addr old; /* Old IP address */
    struct in_addr new; /* New IP address */
} replacenatip;
s=socket(...); /* RAW socket */
struct replacenatip map;
map.old = inet_addr("10.0.1.5"); /* old actual IP */
map.new = inet_addr("10.0.2.7"); /* new actual IP */
setsockopt(s, SO_REPLACE_NAT_IP, &map);

```

In Linux NAT, SNAT can be applied only in post-routing (and not in pre-routing) and DNAT can be applied only in pre-routing (and not in post-routing) stages. This means, for intra-domain sessions, the destination is converted from virtual to actual IP before a routing decision is made, and then after the routing decision is made, the source converted from actual to virtual. This causes a problem with the application level helper function, like FTP module in Linux NAT. The FTP helper module traps the signaling messages, opens the appropriate ports and creates the association with the old connection. For example, consider a node with private address 10.0.1.5 does an FTP transfer to external host 128.59.16.149, and the NAT has allocated the external IP of 135.180.32.4 and port 7088 for this connection. When the node sends an FTP command to download a file, the FTP module in the NAT 411 traps the message and changes the source IP and port to that of the external IP and a chosen port. Now the FTP server sends the data packets to this new port of NAT 411. The NAT 411 in turn forwards the packet to the actual IP and port from the initial signaling message of the private node. Now if the actual IP changes from 10.0.1.5 to 10.0.2.7 the FTP module does not know about this change and the old association for the data traffic breaks.

In general, NAT causes a problem for any protocol that uses the IP address in the signaling messages, e.g., FTP, RTSP and SIP, because the signaling messages generated by the private node contain the private IP address in the messages, whereas the external public host expects a public address. Linux NAT provides hooks to plug in helper modules (e.g., FTP helper

module) to examine the signaling message and alter future IP datagrams related to this signaling session. However, with MobileNAT, the FTP module also breaks, since the association is maintained with respect to the actual IP rather than the virtual IP. Linux NAT does not allow SNAT in the pre-routing stage so the actual source IP is not changed to the virtual source IP before the FTP module is invoked. An alternative approach is to use two different NATs. An internal NAT changes the virtual IP to actual IP and vice-versa, and the external NAT applies the standard masquerade table for the virtual IP to external IP and port for the connection. However, this involves more processing as the translation needs to be done twice. In other embodiments, the FTP and other helper modules may be enhanced to also provide setsockopt to change the IP from old to new.

#### DHCP server

The udhcp DHCP server is enhanced to support MobileNAT. The modifications for virtual IP address affects only MobileNAT hosts, and the server can still be used to allocate IP addresses to non-MobileNAT hosts. FIG. 15 is a flow-chart for processing at the DHCP server 410. The server 410 maintains a range of virtual IP addresses and set of ranges for actual IP addresses for different subnets.

At step 1500, the DHCP server 410 reads the configuration of the NAT domain, including the DHCP relays included therein.

At step 1502, the server 410 receives a packet, which may be from a mobile node previously assigned virtual and/or actual IP addresses, or from a newly activated mobile node that has not been assigned a virtual or actual IP address.

At step 1504, the server 410 processes the request. Steps 1500 to 1504 are repeated for each packet.

The details of processing a packet are shown by steps 1506-1540.

At step 1506, the server 410 determines the type of message. If the client indicates that it does not yet have a virtual IP address (by providing a virtual IP address of 0.0.0.0 in the options), step 1508 is executed. Step 1508 is always the path selected if the mobile node sends a DISCOVER message. If the packet is a REQUEST message, step 1518 is executed.

At step 1508, the server 410 determines whether the mobile node has a valid lease on the pertinent actual IP address.

If the mobile node has a valid lease for a given actual IP address, then at step 1510, server 410 assigns the leased IP address as the actual IP address. Then step 1517 is executed.

If (at step 1508) there is no valid lease, then step 1512 is executed. At step 1512, the IP options requested in the DISCOVER message are examined. The mobile node provides its MAC address to the server 410.

At step 1514, if an IP address is requested, then the requested actual IP address is assigned to the mobile node. Then step 1517 is executed.

At step 1516, if no IP address is specified in the DISCOVER message, then server 410 finds a free address. Then step 1517 is executed.

At step 1517, the server 410 sends an OFFER message to the mobile node, inviting the mobile node to contact the server further.

If the message type is REQUEST, then at step 1518, server 410 determines whether the mobile node has a valid lease. If not, then at step 1520, the REQUEST is ignored.

If a valid lease exists at step 1518, then at step 1522, the server 410 determines whether the requested actual IP address is within the allowable range for the subnet in which the mobile node is currently located (determined by the location of the access point used). If not, then at step 1538, server 410 sends a NACK to mobile node MN. In response to the

NACK, the mobile node will send a new request, including its previously assigned virtual IP address and its MAC address (in place of an actual IP address).

If, at step 1522, the actual IP address of the mobile node is within the allowable range for the subnet in which the mobile node is currently located, then step 1524 is executed. At step 1524, server 410 determines whether a matching serverid is present in the configuration parameters and the requested IP matches. If the answer is "yes," then at step 1540, server 410 sends an ACK to the mobile node. This indicates that the mobile node can continue to use the requested virtual and actual IP addresses.

If, at step 1524, either the serverid is absent or not matching, or the requested IP does not match, then step 1526 is executed. At step 1526, a determination is made whether a requested IP is present in the IP options.

If there is a requested IP, step 1528 is executed. At step 1528, a determination is made whether the requested IP equals the IP leased by this mobile node. If the answer is "yes," then server 410 sends an ACK to the mobile node, renewing the lease on the requested IP addresses.

If the requested IP does not equal the IP leased by this mobile node, then step 1530 is executed, by sending a NACK to the mobile node. In response to the NACK, the mobile node will send a new request, including its previously assigned virtual IP address and its MAC address (in place of an actual IP address).

For the case where the requested IP is not present, at step 1532, if the client address equals the leased address, then step 1534 is executed by sending an ACK.

For the case where the requested IP is not present, at step 1532, if the client address does not equal the leased address, then step 1536 is executed by sending a NACK.

Note that a new IP address is allocated in response to a DISCOVER message, whereas the existing allocated IP is returned in response to a REQUEST message.

The virtual IP address is returned in the Shim layer address option in both OFFER and ACK only if the corresponding request had a Shim layer address option. The actual IP address is allocated based on the sub-net of the relay agent.

Once virtual and actual IP are allocated for a host, the DHCP server updates the SNAT and DNAT tables in NAT to map the actual source IP to virtual source IP and the virtual destination IP to the actual destination IP for the packets coming in and going out on internal interface respectively. Note that SNAT and DNAT are not applied for the connection from internal private node to external public node. These are used only for intra-domain sessions.

If the DHCP server detects that the actual IP was changed for a give virtual IP for a node, then it also updates the connection tracking module with setsockopt command to change the internal hash-table for the connection.

#### Mobility Manager

The mobility manager 412 does the following things:

Receives notification about actual and virtual IP address allocation from DHCP server 410.

Update NAT packet processing rules using the Midcom framework.

Listen to administrative commands from other MM in other NAT domains for connection list, or change in IP address.

Inform the DHCP server 410 to renew a given virtual IP address for a node which has left this domain.

In one exemplary embodiment, the MM is part of the DHCP server and has only limited functionality. In other embodiments, the MM may be implemented in a standalone hardware or software component.

## 15

## Client Side Components

## Driver Functions

The Network Driver Interface Specification (NDIS) is a set of standards developed by Microsoft and 3COM for network drivers that enables (1) communication between a Network Interface Card (NIC) and a protocol (such as TCP/IP or Net-BIOS), and (2) use of multiple protocols on the same network. The Windows OS supports several types of kernel-mode network drivers. For instance, a miniport driver directly manages a network interface card (NIC) and provides an interface to higher-level drivers. An intermediate driver interfaces between upper-level protocol drivers, such as a legacy transport driver, and a miniport driver. A typical reason to develop an intermediate protocol driver is to perform media translation between an existing legacy transport driver and a miniport driver that manages a NIC for a new media type unknown to the transport driver. An upper-level protocol driver implements a transport driver interface (TDI) or an application-specific interface, at its upper edge to provide services to users of the network. At its lower edge, a protocol driver provides a protocol interface to pass packets to and receive incoming packets from the next-lower driver. In addition, there can be a filter-hook driver to extend the functionality of the IP filter driver in the OS.

In one embodiment, a new intermediate driver exposes itself as a miniport driver to the protocol level and a protocol driver to the miniport level drivers. The relationships between miniport drivers, protocol drivers, intermediate drivers and NDIS are illustrated in FIG. 16.

One problem with the Windows network driver implementation is that the TCP/IP and bunch of other protocols like ARP, DHCP, ICMP, etc., are combined into a single black-box called the TCP/IP.sys driver. Since the application developer and driver developers do not have control over the intermediate functionality of the different layers like TCP and IP, or different protocols like DHCP and ICMP, much functionality is duplicated in the intermediate driver, to handle the DHCP, ARP, and re-computation of check-sum when an IP address changes from actual to virtual and vice-versa.

In one embodiment, the shim-layer **200** is implemented as an intermediate driver. It forwards all the DHCP messages to the external MobileNAT client. Shim layer **200** gets notification of its actual IP, virtual IP, subnet mask and gateway IP from this MobileNAT client **1201**. Once the shim layer **200** gets its gateway IP, it initiates an outgoing ARP request for this gateway IP to get the MAC address of the gateway. The MobileNAT client **1201** is responsible for sending the DHCP responses to the client DHCP requests from TCP/IP layer **202**, **204**. It also does the actual DHCP client transactions with the external DHCP server **410** to get the actual IP, virtual IP, subnet mask, gateway IP and other configuration parameters.

The intermediate driver, called the Passthru driver is modified from the Windows DDK example driver. Essentially the driver examines all the messages going in either direction. If the packet contains a DHCP message, then the packet is forwarded to the registered client application. The driver allows registering client applications as message consumers. A DHCP message is essentially a UDP message with source port **68** and destination port **67** for outgoing direction, and source port **67** and destination port **68** for the incoming direction. The DHCP standard client port is **68** and server port is **67**.

The driver also provides a new ioctl command to set the mode to one of MOBILE\_IP\_HOME, MOBILE\_IP\_FOREIGN, MOBILE\_NAT\_TRANSLATE and PASSTHRU. In

## 16

the PASSTHRU mode the driver acts as a passthru module without modifying any packet. The other modes allow a single driver to be used in the MobileIP and MOBILENAT clients. Other ioctl commands are used in MOBILENAT mode to set the virtual IP, actual IP, gateway IP and subnet mask.

In the MOBILE\_NAT\_TRANSLATE mode the packet is processing in the outgoing direction in virtual-miniport as follows:

---

```

if the ethernet type is IP
  if the IP protocol type is UDP
    if the source port is 68 and destination port is 67
      if there is any registered message consumer
        forward the packet to the consumer
      else
        pass the packet normally
    if the source IP is virtual IP
      change the source IP to actual IP
      recompute the IP checksum
      recompute the UDP or TCP checksum as appropriate
    if the destination IP is not in the same subnet
      as the actual IP and the destination IP is
      not the broadcast IP
      change the destination MAC to that of the
      default gateway
  else if the ethernet type is ARP
    if the direction is outgoing request
      if the ARP is done for default gateway IP
        indicate the cached gateway MAC to higher layer
        initiate a new ARP for the gateway IP
      else if the ARP is done for an IP that is not
      in the local subnet
        indicate the cached gateway MAC
      else
        pass the ARP request to lower miniport
    else if the direction is outgoing response
      drop the request

```

---

The incoming packet is processed in virtual-protocol layer as follows:

---

```

if the ethernet type is IP
  if the IP protocol type is UDP
    if the source port is 67 and the destination port is 68
      if a message consumer is registered
        forward the DHCP packet to the consumer
      else
        pass the DHCP message to the higher protocol layer
    if the destination IP is actual IP
      change the destination IP to virtual IP
      recompute IP checksum
      recompute the UDP or TCP checksum as appropriate
  else if the ethernet type is ARP
    if the direction is incoming ARP request
      if the target IP is actual IP
        respond with the local MAC address
      else
        drop the request
    else if the direction is incoming ARP response
      if the target IP is actual IP
        if the source IP is the gateway IP
          cache the gateway MAC address
      else if the target IP is virtual IP
        forward the response to higher protocol layer

```

---

One embodiment detects if the IP address is in the same subnet as the actual IP by masking the IP address and the actual IP address with the actual subnet mask. If the masked network part are same then the two IP addresses are in the same subnet.

The connection status indication (media disconnect or connect) from the miniport are blocked at the driver so that the higher TCP/IP layer never knows about the network disconnection.

#### MobileNAT Client

The MobileNAT client **1201** implements a DHCP client state machine as shown in R. Droms., "Dynamic host configuration protocol." RFC 2131, Internet Engineering Task Force, March 1997, which is incorporated by reference herein. However, to combat the huge DHCP latency the timer values are manipulated for faster response. The client, mnat-c.exe must be running on the mobile node for MobileNAT functionality. The client state machine is explained in the following pseudo-code.

---

```

If the message is from TCP/IP layer
  if the DHCP state is not active
    put the message as pending
  else
    respond to the request
else if the message if from miniport layer
  if the message is connect status
    perform DHCP client transactions again
  else if the message is a DHCP response
    trigger the event in the DHCP client state machine
If the DHCP client state is idle
  start the DHCP client state machine
At any time in the DHCP client state machine
if the state becomes active
  respond to any pending message from TCP/IP layer
  store all the configuration parameters

```

---

The client **1201** responds with the virtual IP address to the TCP/IP layer in the DHCP response. The default gateway address is fixed as 10.0.0.1 and the subnet mask is 255.0.0.0. Other parameters, like DNS server IP address, domain name, server id, etc., are passed as they are received from the actual DHCP server.

In a way, the client **1201** implements a DHCP server to respond to the DHCP requests from the TCP/IP layer **202**, **204**, and a DHCP client to actually request the external DHCP server for configuration parameters. The response to the TCP/IP layer **202**, **204** indicates that the virtual IP lease will never expire, whereas the client state machine takes care of renewing the actual IP lease from the external DHCP server **410** before it expires, transparent to the TCP/IP layer. Since the media disconnect indication is blocked in the shim layer **200**, TCP/IP layer **202**, **204** does not know about the media status and does not initiate any new DHCP translation when the cable is re-connected.

One embodiment **1301** (FIG. 13) separates the DHCP client and server functions **1304** from the MobileNAT client **1303** such that the client **1301** can be used by both MobileNAT **1303** and MobileIP **1305** clients as an integrated unified mobility client. The DHCP functionality is used in co-located Mobile IP mode. Secondly, the interface and network selector module **1306** allows selecting the appropriate interface (e.g., if the host has both 3G access and 802.11 access) and appropriate network (e.g., if the host is within range of two different access points, it can use the signal strength and/or user defined priority to determine which interface type and access point to choose). These modules enable a unified mobility client that can operate in Simple IP, Mobile IP or Mobile NAT modes as needed.

#### Security

Several security design issues are addressed below:

Mobile node is authorized to use the access point. This happens even before the first DHCP message is exchanged.

The DHCP messages exchanged between the mobile node and the DHCP server are authenticated. The timestamp is included in the signature to prevent replay attacks. This verifies to the DHCP server **410** that it is talking to the correct client, and to the client that it is talking to the correct server. DHCP authentication is used for this.

The DHCP server **410**, Mobility manager **412** and NAT **411** are mutually trusted entities and provide secure communication among themselves.

The mobility managers **412** in different domains should use appropriate secure communication for signaling.

MobileNAT should work with IP security (IPSec). The AH (authentication header) mode is not possible with network address translator devices in the network, however the ESP (encapsulated security payload) should be allowed. IPsec is used in VPNs (virtual private networks).

MobileNAT should work with transport layer security (TLS) like secure socket layer (SSL).

The inter-domain mobility requires packet flow between two different NATs **411** in two different domains, i.e., the home NAT forwards the packets to the visited NAT. The system should provide an option to allow reverse tunneling from visited NAT to home NAT also such that the visited NAT does not have to spoof the source IP address.

The mobile nodes subscribed to an independent service provider with appropriate authentication, authorization and accounting (AAA) infrastructure should be allowed to roam in the MobileNAT domain.

In some embodiments, using a Mobile IP driver below IPsec provides additional advantages. Typically, when an MN is connected to a network IPsec software will establish a tunnel between the MN and the IPsec gateway that is sitting in some enterprise network. The examples described above enable moving the tunnel (when the MN moves its local attachment). Thus, in addition to mobile IP's general support for moving between networks, the examples allow the tunnel sitting on top to actually moves along with the Mobile IP client movement.

When the MN moves from one network to another, locally, whatever the gateway IPsec remembers would be wrong. In the example, by putting in the Mobility client driver below IPsec, a dummy IP address and a dummy MAC address are provided to the gateway, and then the IPsec client driver remembers that to always be the same. Thus, the IPsec client driver already thinks that it is attached to the same gateway even though underneath the interfaces are changing, and the networks are changing.

In one exemplary implementation, the IPsec client driver inquires about the gateway using ARP by sending a packet down to the network. The inquiry is intercepted, and a MAC address is provided in return, without sending the inquiry out into the network.

#### Optimizations, Extensions and Limitations

A number of other issues like scalability, security, paging, fast-handoff and deployment issues are addressed for a complete mobility solution.

#### Extensions

Route optimization for intra-domain sessions: All packets to the virtual address of MN goes to the NAT devices **411** before getting routed to the actual address of the MN. If an

MN (MN1) is talking to another MN (MN2) in the same NAT domain, then the routing path can be optimized by sending packets directly between the two nodes. However MN1 needs to detect that the other side MN2 is also a MobileNAT client in the same domain and indicate to it the actual IP address, such that the packets by other side MN2 can be sent directly to the actual IP address of MN1. When MN1 moves, the other side MN2 will detect the ICMP host unreachable error and will start sending the packets to the virtual IP (to the NAT 411) again. This requires additional signaling to convey the actual IP of the other end point. There are two options: define a signaling between the two MNs or define a signaling from the NAT/MM to the MN. Either approach should allow secure (authenticated and authorized) signaling.

Co-existence with Mobile IP and Hawaii: If a mobile node MN uses Mobile IP instead of MobileNAT it can still roam in the NAT domain. The only difference is that it does not have a virtual IP address. Other IP based micro-mobility mechanisms (like Hawaii or heirarchical Mobile IP) can also co-exist with the MobileNAT scheme.

Co-existence with other IP clients that are not mobile: A non-mobile client using IP can also exist in the NAT domain.

Embodiments using parts of other existing protocols: Parts of protocols like IDMP, RSIP, IPv6 may be used in some of the exemplary embodiments. For example, address translation from IDMP and destination option from IPv6 can be reused in some embodiments instead of inventing a new signaling option.

IPv6 in NAT domain: With an IPv6 NAT domain, there is no need to use private IP addresses, as there will be plenty of IPv6 public addresses. This involves the case when the MN has virtual and actual public IP addresses. However, the NAT device 411 is still used to translated between this IPv6 domain and the external IPv6 public Internet.

Single unified Mobile IP and Simple IP client: One embodiment (not shown) includes a combined unified mobile IP, simple IP and MobileNAT client such that the client can use the best available and best suited mechanism for mobility and network access. For instance, if a foreign agent is not found but a mobility manager is present, then it uses the MobileNAT scheme, whereas if a foreign agent is found and a mobility manager is also present but the user wants to host a service (e.g., web server) then it may use the Mobile IP scheme with a well known external public IP address.

Mobility to 3G network: Some embodiments use the system to provide mobility to a node in 3G network. The NAT, mobility manager and DHCP server sit on the packet data serving node (PDSN) of the 3G network.

Paging using IP multicast: Some embodiments may reuse existing IP multicast based paging mechanisms in MobileNAT.

Multiple NAT for load balancing: In some embodiments, it may be desirable to share the address translation load among multiple distributed NAT devices in a single domain. Secondly, in some embodiments, a network can have more than one NAT devices along the path from MN to CN.

Services by mobile node using DNS updates or public IP address: If a mobile user wants to host a public service (e.g., web server or media server) it should be accessible from outside the NAT domain. This is a generic problem with NAT. In some embodiments, the MobileNAT system is extended to allow leasing a public virtual IP address to the internal node from the external public address pool available with the NAT device. Alternatively, dynamic DNS updates can be used to update the host name to IP address mapping for the mobile node.

AAA integration: In some embodiments, the system may integrate with existing authentication mechanisms, e.g., using Remote Authentication Dial-In User Service (RADIUS), to an external AAA infrastructure.

MobileNAT at both end-points: If MobileNAT is used at both the end-points in the connection, then there is no need for any intermediate NAT device. However, additional signaling is used between the two endpoints to convey the mappings as DHCP can not be used.

Change in the client: In the examples described above, the client software is changed (installing the shim layer driver 200 and running the MobileNAT client 1201). Even Mobile IP requires change in the client software. An alternative approach could be to move the address translation function from the shim layer to the default gateway (or foreign agent) in the sub-net. However, this alternative approach requires deploying foreign agents in every domain. Changing the client machine may be easier than change in the infrastructure, given that installing a new software or driver is simple for the Microsoft Windows users.

Fast hand-off and DHCP latency: DHCP introduces additional latency that is not suitable for fast hand-off. In some embodiments, the DHCP implementation is modified so as to remove the timeouts on mobility (of the mobile node). However this approach implies a non-standard DHCP implementation. Alternatively a different signaling protocol may be used for mobility between the mobile node and the mobility manager.

Intra-domain session in the case of inter-domain mobility: If a mobile node is talking to another node in the same domain, and the mobile node moves to another domain, there can be problems, as noted above. (This kind of problem happens only when there is a collision in the IP address in the new domain.) These can be resolved by user intervention. The user can choose to continue with the existing sessions and do not allow new sessions, or stop the existing sessions and start afresh. An alternative approach is to allocate exclusive-or (independent) range of virtual IP addresses among different NAT domains. This procedurally ensures that a mobile node in one NAT domain does not have the same virtual IP address as another mobile node in a different NAT domain. This may be relatively easy to implement in a single service provider network with multiple NAT domains.

Application layer signaling with NAT: As discussed above, NAT causes problems with application level protocols like SIP, FTP and RTSP that use the IP address in the signaling messages. The NAT implementation should allow helper functions for these protocols to take care of the change in actual IP address without breaking the connection. In some alternative embodiments, existing helper functions in Linux NAT can be used with virtual IP address instead of actual IP address. This approach uses double translation at the NAT device, first from actual IP to virtual IP and then from virtual IP to the external public IP address of the NAT device.

In some embodiments, intra-domain sessions are optimized to reduce load on the NAT.

The exemplary embodiment does not require any change in the routing infrastructure in the domain and does not require any foreign agent. A domain wide DHCP server, NAT and mobility manager are deployed. Most routers have built-in address translation functions that can be enabled.

Midcomm framework allows separating the mobility manager from the NAT device.

The exemplary embodiments are easy to use and easy to deploy.

The present invention may be embodied in the form of computer-implemented processes and apparatus for practic-

## 21

ing those processes. The present invention may also be embodied in the form of computer program code embodied in tangible media, such as floppy diskettes, read only memories (ROMs), CD-ROMs, hard drives, ZIP™ disks, flash memory, or any other computer-readable storage medium, wherein, when the computer program code is loaded into and executed by a computer, the computer becomes an apparatus for practicing the invention. The present invention may also be embodied in the form of computer program code, for example, whether stored in a storage medium, loaded into and/or executed by a computer, or transmitted over some transmission medium, such as over the electrical wiring or cabling, through fiber optics, or via electromagnetic radiation, wherein, when the computer program code is loaded into and executed by a computer, the computer becomes an apparatus for practicing the invention. When implemented on a general-purpose processor, the computer program code segments configure the processor to create specific logic circuits.

Although the invention has been described in terms of exemplary embodiments, it is not limited thereto. Rather, the appended claims should be construed broadly, to include other variants and embodiments of the invention, which may be made by those skilled in the art without departing from the scope and range of equivalents of the invention.

We claim:

1. A method for addressing a mobile node, comprising the steps of:

identifying a mobile node to a corresponding node, with which the mobile node communicates, at a level above a network level using an invariant virtual internet protocol (IP) address of the mobile node;

identifying the mobile node to a network address translation (NAT) device at a network interface level using a routable actual IP address of the mobile node; and

changing the actual IP address of the mobile node used by the NAT device, and a rule for mapping the actual IP address to the virtual IP address, without varying the virtual IP address of the mobile node used by the corresponding node, as the mobile node moves intra-domain or inter-domain.

2. The method of claim 1, wherein the virtual IP address is used for maintaining a transport level protocol connection while the mobile node moves between a first subnet and a second subnet.

3. The method of claim 1, further comprising:

receiving a packet from an application in the mobile node, the packet including the virtual IP address of the mobile node as a source address;

translating the virtual IP address of the mobile node to the actual IP address of the mobile node for use as the source address; and

transmitting the packet with the actual IP address from the mobile node.

4. The method of claim 3, wherein the actual IP address is a local private address, the method further comprising:

translating the actual IP address of the mobile node to a public IP address; and

transmitting the packet with the public IP address to the corresponding node, the mobile node and the corresponding node being in different domains connected to each other by a public network.

5. The method of claim 4, further comprising:

receiving an incoming packet from the corresponding node in the NAT device, the incoming packet having the public IP address as a destination;

## 22

a first translating step of translating the public IP address to the actual IP address of the mobile node, the first translating step being performed in the NAT device;

a second translating step of translating the actual IP address of the mobile node to the virtual IP address of the mobile node, the second translating step being performed in the mobile node; and

providing the incoming packet with the virtual IP address as a destination for delivery to the application in the mobile node.

6. The method of claim 1, further comprising:

transmitting a packet from an application in the mobile node to the corresponding node, the transmitted packet having the virtual IP address of the mobile node as the source address, the mobile node and the corresponding node belonging to different subnets within a common domain; and

receiving an incoming packet from the corresponding node by way of the NAT device, wherein the NAT device translates a destination address of the incoming packet from the virtual IP address of the mobile node to the actual IP address of the mobile node.

7. The method of claim 6, wherein the corresponding node is a second mobile node, and the transmitted packet has a destination address that is a virtual IP address of the corresponding node, and the packet is transmitted to the corresponding node by way of the NAT device, the method further comprising:

translating the virtual IP address of the corresponding node within the packet to an actual IP address of the corresponding node in the NAT device.

8. The method of claim 7, wherein the transmitted packet is transmitted to the corresponding node by way of the NAT device, the method further comprising:

translating the source address of the transmitted packet from the actual IP address of the mobile node to the virtual IP address of the mobile node, in the NAT device.

9. The method of claim 1, further comprising:

using the NAT device within a first NAT domain as a home agent for the mobile node while the mobile node communicates with a first corresponding node in a first connection initiated while the mobile node is located in the first NAT domain; and

using a second NAT device within a second NAT domain as a home agent for the mobile node while the mobile node communicates with the first corresponding node or a second corresponding node in a second connection initiated while the mobile node is located in the second NAT domain.

10. The method of claim 9, further comprising using a packet processing rule for processing traffic from the mobile node, while the mobile node is in the second NAT domain, the packet processing rule being obtained from a device in the first NAT domain.

11. The method of claim 10, wherein when the mobile node moves from the first NAT domain to the second NAT domain, a mobility manager in the second NAT device requests and receives the packet processing rule from a mobility manager of the first NAT domain, wherein the first and second mobility managers have centralized views of users in the first and second NAT domains, respectively, and mappings between virtual IP addresses and actual IP addresses of the users currently in the first and second NAT domains, respectively.

12. The method of claim 9, wherein the first and second connections partially overlap in time, so that the first and second NAT devices act as first and second home agents for the mobile node concurrently.

## 23

13. The method of claim 12, wherein the mobile node has the same virtual address for both the first and second connections.

14. The method of claim 12, wherein an additional node in the second NAT domain has the same virtual address as the mobile node, the method further comprising:

assigning a second virtual address to the mobile node for connections initiated after the mobile node moves to the second domain; and

continuing to use the first virtual address for connections initiated by the mobile node using the first virtual address, the continuing use of the first virtual address being concurrent with use of the second virtual address for connections initiated after the second virtual address is assigned to the mobile node.

15. The method of claim 1, further comprising: assigning the virtual and actual IP addresses using Dynamic Host Configuration Protocol.

16. The method of claim 1, further comprising translating the virtual IP address to a public IP address in the NAT device.

17. The method of claim 1, further comprising dividing an available range of private IP addresses into a first range to be used for actual IP addresses and a second range to be used for virtual IP addresses.

18. A mobile node, comprising:

a processor;

a network interface; and

a storage device having computer program code therein for execution by the processor, the computer program code including:

a network layer for transmitting and receiving packets; and an intermediate driver that transmits packets to the network layer and receives packets from the network layer using

## 24

a virtual internet protocol (IP) address to identify the mobile node, the intermediate driver transmitting packets to the network interface and receiving packets from the network interface using a routable actual IP address to identify the mobile node, wherein the intermediate driver permits the actual IP address to change when the mobile node moves intra-domain or inter-domain without a corresponding change in the virtual IP address.

19. The mobile node of claim 18, wherein the intermediate driver includes means for changing a source IP address of packets transmitted by the mobile node from the virtual address to the actual address.

20. The mobile node of claim 18, wherein the intermediate driver includes means for encapsulating packets transmitted by the mobile node.

21. The mobile node of claim 18, wherein the intermediate driver includes means for changing a destination IP address of packets received by the mobile node from the actual address to the virtual address.

22. The mobile node of claim 18, further comprising means for requesting and receiving from a dynamic host configuration protocol (DHCP) server the virtual IP address and the actual IP address upon startup of the mobile node.

23. The mobile node of claim 22, further comprising means for transmitting the virtual IP address to the DHCP server when the mobile node moves to the second subnet, to allow a new actual IP address to be associated with the virtual IP address.

24. The mobile node of claim 18, further comprising a mobile IP client that transmits and receives packets by way of the network layer, the intermediate driver and the network interface.

\* \* \* \* \*