



UNITED STATES PATENT AND TRADEMARK OFFICE

UNITED STATES DEPARTMENT OF COMMERCE
United States Patent and Trademark Office
Address: COMMISSIONER FOR PATENTS
P.O. Box 1450
Alexandria, Virginia 22313-1450
www.uspto.gov

Table with 5 columns: APPLICATION NO., FILING DATE, FIRST NAMED INVENTOR, ATTORNEY DOCKET NO., CONFIRMATION NO. Includes application details for Gregory G. Raleigh and examination information for RUDY, ANDREW J.

Please find below and/or attached an Office communication concerning this application or proceeding.

The time period for reply, if any, is set in the attached communication.

Notice of the Office communication was sent electronically on above-indicated "Notification Date" to the following e-mail address(es):

patent@headwaterllc.com

<b>Corrected Notice of Allowability</b>	<b>Application No.</b> 14/208,236	<b>Applicant(s)</b> RALEIGH ET AL.	
	<b>Examiner</b> ANDREW JOSEPH RUDY	<b>Art Unit</b> 3687	<b>AIA (First Inventor to File) Status</b> No

**-- The MAILING DATE of this communication appears on the cover sheet with the correspondence address--**

All claims being allowable, PROSECUTION ON THE MERITS IS (OR REMAINS) CLOSED in this application. If not included herewith (or previously mailed), a Notice of Allowance (PTOL-85) or other appropriate communication will be mailed in due course. **THIS NOTICE OF ALLOWABILITY IS NOT A GRANT OF PATENT RIGHTS.** This application is subject to withdrawal from issue at the initiative of the Office or upon petition by the applicant. See 37 CFR 1.313 and MPEP 1308.

1.  This communication is responsive to the two February 8, 2017 Information Disclosure Statements.  
 A declaration(s)/affidavit(s) under **37 CFR 1.130(b)** was/were filed on \_\_\_\_\_.
2.  An election was made by the applicant in response to a restriction requirement set forth during the interview on \_\_\_\_\_; the restriction requirement and election have been incorporated into this action.
3.  The allowed claim(s) is/are 1-47 and 49. As a result of the allowed claim(s), you may be eligible to benefit from the **Patent Prosecution Highway** program at a participating intellectual property office for the corresponding application. For more information, please see [http://www.uspto.gov/patents/init\\_events/pph/index.jsp](http://www.uspto.gov/patents/init_events/pph/index.jsp) or send an inquiry to [PPHfeedback@uspto.gov](mailto:PPHfeedback@uspto.gov).
4.  Acknowledgment is made of a claim for foreign priority under 35 U.S.C. § 119(a)-(d) or (f).

**Certified copies:**

- a)  All    b)  Some    \*c)  None of the:
1.  Certified copies of the priority documents have been received.
  2.  Certified copies of the priority documents have been received in Application No. \_\_\_\_\_.
  3.  Copies of the certified copies of the priority documents have been received in this national stage application from the International Bureau (PCT Rule 17.2(a)).

\* Certified copies not received: \_\_\_\_\_.

Applicant has THREE MONTHS FROM THE "MAILING DATE" of this communication to file a reply complying with the requirements noted below. Failure to timely comply will result in ABANDONMENT of this application.

**THIS THREE-MONTH PERIOD IS NOT EXTENDABLE.**

5.  CORRECTED DRAWINGS ( as "replacement sheets") must be submitted.  
 including changes required by the attached Examiner's Amendment / Comment or in the Office action of Paper No./Mail Date \_\_\_\_\_.  
**Identifying indicia such as the application number (see 37 CFR 1.84(c)) should be written on the drawings in the front (not the back) of each sheet. Replacement sheet(s) should be labeled as such in the header according to 37 CFR 1.121(d).**
6.  DEPOSIT OF and/or INFORMATION about the deposit of BIOLOGICAL MATERIAL must be submitted. Note the attached Examiner's comment regarding REQUIREMENT FOR THE DEPOSIT OF BIOLOGICAL MATERIAL.

**Attachment(s)**

- |  |  |
|--|--|
| 1. <input type="checkbox"/> Notice of References Cited (PTO-892)   | 5. <input checked="" type="checkbox"/> Examiner's Amendment/Comment                  |
| 2. <input checked="" type="checkbox"/> Information Disclosure Statements (PTO/SB/08),<br>Paper No./Mail Date _____ | 6. <input checked="" type="checkbox"/> Examiner's Statement of Reasons for Allowance |
| 3. <input type="checkbox"/> Examiner's Comment Regarding Requirement for Deposit<br>of Biological Material         | 7. <input type="checkbox"/> Other _____.   |
| 4. <input type="checkbox"/> Interview Summary (PTO-413),<br>Paper No./Mail Date _____.                             |  |

--	--

**DETAILED ACTION**

***Notice of Pre-AIA or AIA Status***

1. The present application is being examined under the pre-AIA first to invent provisions.
2. Applicant cancelled claim 48.
3. Applicant's two Information Disclosure Statements (IDS's) submitted February 8, 2017 been reviewed. Note the attached IDS's.

***Allowable Subject Matter***

4. Claims 1-47 and 49 are allowed.
5. The following is an examiner's statement of reasons for allowance: Applicant's November 23, 2016 Amendment and REMARKS along with the two Information Disclosure Statements (IDS's) submitted February 8, 2017 have been reviewed. Pursuant thereto, claims 1-47 and 49 are now allowed as the prior art, either alone or in combination, does not disclose Applicant's inventive claim language.

Claims 1-47 and 49 have been reviewed in light of Alice Corporation Pty. Ltd. v. CLS Bank International, et al., 573 U. S. \_\_\_\_ (2014) and are not deemed invalidated by such.

Claims 1-47 and 49 are determined to be directed to patent-eligible subject matter and the Examiner does not consider any of the pending claims to be directed to an abstract idea. Even if the Examiner were to identify an abstract idea for any claim, then under a further analysis under Alice all claims would still be found to be patent eligible for the following reasons. The Examiner finds that when all of the elements of each claim are considered individually and as an ordered combination, each claim contains an inventive concept which is directed to an application, a particular application, or a special application, of the identified abstract idea. Further the Examiner finds that issuance of a patent for any claim would not preempt the identified abstract idea, or the field of the identified abstract idea.

Any comments considered necessary by applicant must be submitted no later than the payment of the issue fee and, to avoid processing delays, should preferably accompany the issue fee. Such submissions should be clearly labeled "Comments on Statement of Reasons for Allowance."

6. Any inquiry concerning this communication or earlier communications from the examiner should be directed to ANDREW JOSEPH RUDY whose telephone number is (571)272-6789. The examiner can normally be reached on Monday thru Friday.

If attempts to reach the examiner by telephone are unsuccessful, the examiner's supervisor, Fahd A. Obeid can be reached on 571-270-3324. The fax phone number for the organization where this application or proceeding is assigned is 571-273-8300.

Information regarding the status of an application may be obtained from the Patent Application Information Retrieval (PAIR) system. Status information for published applications may be obtained from either Private PAIR or Public PAIR. Status information for unpublished applications is available through Private PAIR only. For more information about the PAIR system, see <http://pair-direct.uspto.gov>. Should you have questions on access to the Private PAIR system, contact the Electronic Business Center (EBC) at 866-217-9197 (toll-free). If you would like assistance from a USPTO Customer Service Representative or access to the automated information system, call 800-786-9199 (IN USA OR CANADA) or 571-272-1000.

/ANDREW JOSEPH RUDY/  
Primary Examiner  
Art Unit 3687



UNITED STATES PATENT AND TRADEMARK OFFICE

UNITED STATES DEPARTMENT OF COMMERCE
United States Patent and Trademark Office
Address: COMMISSIONER FOR PATENTS
P.O. Box 1450
Alexandria, Virginia 22313-1450
www.uspto.gov

NOTICE OF ALLOWANCE AND FEE(S) DUE

106963 7590 01/12/2017
Headwater Research LLC
1011 Pruitt Place
Tyler, TX 75703

EXAMINER

RUDY, ANDREW J

ART UNIT PAPER NUMBER

3687

DATE MAILED: 01/12/2017

Table with 5 columns: APPLICATION NO., FILING DATE, FIRST NAMED INVENTOR, ATTORNEY DOCKET NO., CONFIRMATION NO.

14/208,236 03/13/2014 Gregory G. Raleigh RALEP115 1058

TITLE OF INVENTION: AUTOMATED CREDENTIAL PORTING FOR MOBILE DEVICES

Table with 7 columns: APPLN. TYPE, ENTITY STATUS, ISSUE FEE DUE, PUBLICATION FEE DUE, PREV. PAID ISSUE FEE, TOTAL FEE(S) DUE, DATE DUE

nonprovisional SMALL \$480 \$0 \$0 \$480 04/12/2017

THE APPLICATION IDENTIFIED ABOVE HAS BEEN EXAMINED AND IS ALLOWED FOR ISSUANCE AS A PATENT. PROSECUTION ON THE MERITS IS CLOSED. THIS NOTICE OF ALLOWANCE IS NOT A GRANT OF PATENT RIGHTS. THIS APPLICATION IS SUBJECT TO WITHDRAWAL FROM ISSUE AT THE INITIATIVE OF THE OFFICE OR UPON PETITION BY THE APPLICANT. SEE 37 CFR 1.313 AND MPEP 1308.

THE ISSUE FEE AND PUBLICATION FEE (IF REQUIRED) MUST BE PAID WITHIN THREE MONTHS FROM THE MAILING DATE OF THIS NOTICE OR THIS APPLICATION SHALL BE REGARDED AS ABANDONED. THIS STATUTORY PERIOD CANNOT BE EXTENDED. SEE 35 U.S.C. 151. THE ISSUE FEE DUE INDICATED ABOVE DOES NOT REFLECT A CREDIT FOR ANY PREVIOUSLY PAID ISSUE FEE IN THIS APPLICATION. IF AN ISSUE FEE HAS PREVIOUSLY BEEN PAID IN THIS APPLICATION (AS SHOWN ABOVE), THE RETURN OF PART B OF THIS FORM WILL BE CONSIDERED A REQUEST TO REAPPLY THE PREVIOUSLY PAID ISSUE FEE TOWARD THE ISSUE FEE NOW DUE.

HOW TO REPLY TO THIS NOTICE:

I. Review the ENTITY STATUS shown above. If the ENTITY STATUS is shown as SMALL or MICRO, verify whether entitlement to that entity status still applies.

If the ENTITY STATUS is the same as shown above, pay the TOTAL FEE(S) DUE shown above.

If the ENTITY STATUS is changed from that shown above, on PART B - FEE(S) TRANSMITTAL, complete section number 5 titled "Change in Entity Status (from status indicated above)".

For purposes of this notice, small entity fees are 1/2 the amount of undiscounted fees, and micro entity fees are 1/2 the amount of small entity fees.

II. PART B - FEE(S) TRANSMITTAL, or its equivalent, must be completed and returned to the United States Patent and Trademark Office (USPTO) with your ISSUE FEE and PUBLICATION FEE (if required). If you are charging the fee(s) to your deposit account, section "4b" of Part B - Fee(s) Transmittal should be completed and an extra copy of the form should be submitted. If an equivalent of Part B is filed, a request to reapply a previously paid issue fee must be clearly made, and delays in processing may occur due to the difficulty in recognizing the paper as an equivalent of Part B.

III. All communications regarding this application must give the application number. Please direct all communications prior to issuance to Mail Stop ISSUE FEE unless advised to the contrary.

IMPORTANT REMINDER: Utility patents issuing on applications filed on or after Dec. 12, 1980 may require payment of maintenance fees. It is patentee's responsibility to ensure timely payment of maintenance fees when due.

**PART B - FEE(S) TRANSMITTAL**

**Complete and send this form, together with applicable fee(s), to: Mail Mail Stop ISSUE FEE  
 Commissioner for Patents  
 P.O. Box 1450  
 Alexandria, Virginia 22313-1450  
 or Fax (571)-273-2885**

**INSTRUCTIONS:** This form should be used for transmitting the ISSUE FEE and PUBLICATION FEE (if required). Blocks 1 through 5 should be completed where appropriate. All further correspondence including the Patent, advance orders and notification of maintenance fees will be mailed to the current correspondence address as indicated unless corrected below or directed otherwise in Block 1, by (a) specifying a new correspondence address; and/or (b) indicating a separate "FEE ADDRESS" for maintenance fee notifications.

CURRENT CORRESPONDENCE ADDRESS (Note: Use Block 1 for any change of address)

106963                      7590                      01/12/2017  
 Headwater Research LLC  
 1011 Pruitt Place  
 Tyler, TX 75703

Note: A certificate of mailing can only be used for domestic mailings of the Fee(s) Transmittal. This certificate cannot be used for any other accompanying papers. Each additional paper, such as an assignment or formal drawing, must have its own certificate of mailing or transmission.

**Certificate of Mailing or Transmission**

I hereby certify that this Fee(s) Transmittal is being deposited with the United States Postal Service with sufficient postage for first class mail in an envelope addressed to the Mail Stop ISSUE FEE address above, or being facsimile transmitted to the USPTO (571) 273-2885, on the date indicated below.

_____ (Depositor's name)
_____ (Signature)
_____ (Date)

APPLICATION NO.	FILING DATE	FIRST NAMED INVENTOR	ATTORNEY DOCKET NO.	CONFIRMATION NO.
14/208,236	03/13/2014	Gregory G. Raleigh	RALEP115	1058

TITLE OF INVENTION: AUTOMATED CREDENTIAL PORTING FOR MOBILE DEVICES

APPLN. TYPE	ENTITY STATUS	ISSUE FEE DUE	PUBLICATION FEE DUE	PREV. PAID ISSUE FEE	TOTAL FEE(S) DUE	DATE DUE
nonprovisional	SMALL	\$480	\$0	\$0	\$480	04/12/2017

EXAMINER	ART UNIT	CLASS-SUBCLASS
RUDY, ANDREW J	3687	705-014000

<p>1. Change of correspondence address or indication of "Fee Address" (37 CFR 1.363).</p> <p><input type="checkbox"/> Change of correspondence address (or Change of Correspondence Address form PTO/SB/122) attached.</p> <p><input type="checkbox"/> "Fee Address" indication (or "Fee Address" Indication form PTO/SB/47; Rev 03-02 or more recent) attached. <b>Use of a Customer Number is required.</b></p>	<p>2. For printing on the patent front page, list</p> <p>(1) The names of up to 3 registered patent attorneys or agents OR, alternatively, _____ 1</p> <p>(2) The name of a single firm (having as a member a registered attorney or agent) and the names of up to 2 registered patent attorneys or agents. If no name is listed, no name will be printed. _____ 2</p> <p>_____ 3</p>
---	---

3. ASSIGNEE NAME AND RESIDENCE DATA TO BE PRINTED ON THE PATENT (print or type)

PLEASE NOTE: Unless an assignee is identified below, no assignee data will appear on the patent. If an assignee is identified below, the document has been filed for recordation as set forth in 37 CFR 3.11. Completion of this form is NOT a substitute for filing an assignment.

(A) NAME OF ASSIGNEE \_\_\_\_\_ (B) RESIDENCE: (CITY and STATE OR COUNTRY) \_\_\_\_\_

Please check the appropriate assignee category or categories (will not be printed on the patent) :  Individual  Corporation or other private group entity  Government

<p>4a. The following fee(s) are submitted:</p> <p><input type="checkbox"/> Issue Fee</p> <p><input type="checkbox"/> Publication Fee (No small entity discount permitted)</p> <p><input type="checkbox"/> Advance Order - # of Copies _____</p>	<p>4b. Payment of Fee(s): (Please first reapply any previously paid issue fee shown above)</p> <p><input type="checkbox"/> A check is enclosed.</p> <p><input type="checkbox"/> Payment by credit card. Form PTO-2038 is attached.</p> <p><input type="checkbox"/> The director is hereby authorized to charge the required fee(s), any deficiency, or credits any overpayment, to Deposit Account Number _____ (enclose an extra copy of this form).</p>
---	---

5. **Change in Entity Status** (from status indicated above)

Applicant certifying micro entity status. See 37 CFR 1.29

Applicant asserting small entity status. See 37 CFR 1.27

Applicant changing to regular undiscounted fee status.

**NOTE:** Absent a valid certification of Micro Entity Status (see forms PTO/SB/15A and 15B), issue fee payment in the micro entity amount will not be accepted at the risk of application abandonment.

**NOTE:** If the application was previously under micro entity status, checking this box will be taken to be a notification of loss of entitlement to micro entity status.

**NOTE:** Checking this box will be taken to be a notification of loss of entitlement to small or micro entity status, as applicable.

NOTE: This form must be signed in accordance with 37 CFR 1.31 and 1.33. See 37 CFR 1.4 for signature requirements and certifications.

Authorized Signature _____	Date _____
Typed or printed name _____	Registration No. _____



UNITED STATES PATENT AND TRADEMARK OFFICE

UNITED STATES DEPARTMENT OF COMMERCE
United States Patent and Trademark Office
Address: COMMISSIONER FOR PATENTS
P.O. Box 1450
Alexandria, Virginia 22313-1450
www.uspto.gov

Table with 5 columns: APPLICATION NO., FILING DATE, FIRST NAMED INVENTOR, ATTORNEY DOCKET NO., CONFIRMATION NO.

106963 7590 01/12/2017
Headwater Research LLC
1011 Pruitt Place
Tyler, TX 75703

EXAMINER

RUDY, ANDREW J

ART UNIT PAPER NUMBER

3687

DATE MAILED: 01/12/2017

Determination of Patent Term Adjustment under 35 U.S.C. 154 (b)
(Applications filed on or after May 29, 2000)

The Office has discontinued providing a Patent Term Adjustment (PTA) calculation with the Notice of Allowance.

Section 1(h)(2) of the AIA Technical Corrections Act amended 35 U.S.C. 154(b)(3)(B)(i) to eliminate the requirement that the Office provide a patent term adjustment determination with the notice of allowance. See Revisions to Patent Term Adjustment, 78 Fed. Reg. 19416, 19417 (Apr. 1, 2013). Therefore, the Office is no longer providing an initial patent term adjustment determination with the notice of allowance. The Office will continue to provide a patent term adjustment determination with the Issue Notification Letter that is mailed to applicant approximately three weeks prior to the issue date of the patent, and will include the patent term adjustment on the patent. Any request for reconsideration of the patent term adjustment determination (or reinstatement of patent term adjustment) should follow the process outlined in 37 CFR 1.705.

Any questions regarding the Patent Term Extension or Adjustment determination should be directed to the Office of Patent Legal Administration at (571)-272-7702. Questions relating to issue and publication fee payments should be directed to the Customer Service Center of the Office of Patent Publication at 1-(888)-786-0101 or (571)-272-4200.

## OMB Clearance and PRA Burden Statement for PTOL-85 Part B

The Paperwork Reduction Act (PRA) of 1995 requires Federal agencies to obtain Office of Management and Budget approval before requesting most types of information from the public. When OMB approves an agency request to collect information from the public, OMB (i) provides a valid OMB Control Number and expiration date for the agency to display on the instrument that will be used to collect the information and (ii) requires the agency to inform the public about the OMB Control Number's legal significance in accordance with 5 CFR 1320.5(b).

The information collected by PTOL-85 Part B is required by 37 CFR 1.311. The information is required to obtain or retain a benefit by the public which is to file (and by the USPTO to process) an application. Confidentiality is governed by 35 U.S.C. 122 and 37 CFR 1.14. This collection is estimated to take 12 minutes to complete, including gathering, preparing, and submitting the completed application form to the USPTO. Time will vary depending upon the individual case. Any comments on the amount of time you require to complete this form and/or suggestions for reducing this burden, should be sent to the Chief Information Officer, U.S. Patent and Trademark Office, U.S. Department of Commerce, P.O. Box 1450, Alexandria, Virginia 22313-1450. DO NOT SEND FEES OR COMPLETED FORMS TO THIS ADDRESS. SEND TO: Commissioner for Patents, P.O. Box 1450, Alexandria, Virginia 22313-1450. Under the Paperwork Reduction Act of 1995, no persons are required to respond to a collection of information unless it displays a valid OMB control number.

### Privacy Act Statement

**The Privacy Act of 1974 (P.L. 93-579)** requires that you be given certain information in connection with your submission of the attached form related to a patent application or patent. Accordingly, pursuant to the requirements of the Act, please be advised that: (1) the general authority for the collection of this information is 35 U.S.C. 2(b)(2); (2) furnishing of the information solicited is voluntary; and (3) the principal purpose for which the information is used by the U.S. Patent and Trademark Office is to process and/or examine your submission related to a patent application or patent. If you do not furnish the requested information, the U.S. Patent and Trademark Office may not be able to process and/or examine your submission, which may result in termination of proceedings or abandonment of the application or expiration of the patent.

The information provided by you in this form will be subject to the following routine uses:

1. The information on this form will be treated confidentially to the extent allowed under the Freedom of Information Act (5 U.S.C. 552) and the Privacy Act (5 U.S.C. 552a). Records from this system of records may be disclosed to the Department of Justice to determine whether disclosure of these records is required by the Freedom of Information Act.
2. A record from this system of records may be disclosed, as a routine use, in the course of presenting evidence to a court, magistrate, or administrative tribunal, including disclosures to opposing counsel in the course of settlement negotiations.
3. A record in this system of records may be disclosed, as a routine use, to a Member of Congress submitting a request involving an individual, to whom the record pertains, when the individual has requested assistance from the Member with respect to the subject matter of the record.
4. A record in this system of records may be disclosed, as a routine use, to a contractor of the Agency having need for the information in order to perform a contract. Recipients of information shall be required to comply with the requirements of the Privacy Act of 1974, as amended, pursuant to 5 U.S.C. 552a(m).
5. A record related to an International Application filed under the Patent Cooperation Treaty in this system of records may be disclosed, as a routine use, to the International Bureau of the World Intellectual Property Organization, pursuant to the Patent Cooperation Treaty.
6. A record in this system of records may be disclosed, as a routine use, to another federal agency for purposes of National Security review (35 U.S.C. 181) and for review pursuant to the Atomic Energy Act (42 U.S.C. 218(c)).
7. A record from this system of records may be disclosed, as a routine use, to the Administrator, General Services, or his/her designee, during an inspection of records conducted by GSA as part of that agency's responsibility to recommend improvements in records management practices and programs, under authority of 44 U.S.C. 2904 and 2906. Such disclosure shall be made in accordance with the GSA regulations governing inspection of records for this purpose, and any other relevant (i.e., GSA or Commerce) directive. Such disclosure shall not be used to make determinations about individuals.
8. A record from this system of records may be disclosed, as a routine use, to the public after either publication of the application pursuant to 35 U.S.C. 122(b) or issuance of a patent pursuant to 35 U.S.C. 151. Further, a record may be disclosed, subject to the limitations of 37 CFR 1.14, as a routine use, to the public if the record was filed in an application which became abandoned or in which the proceedings were terminated and which application is referenced by either a published application, an application open to public inspection or an issued patent.
9. A record from this system of records may be disclosed, as a routine use, to a Federal, State, or local law enforcement agency, if the USPTO becomes aware of a violation or potential violation of law or regulation.

<b>Notice of Allowability</b>	<b>Application No.</b> 14/208,236	<b>Applicant(s)</b> RALEIGH ET AL.	
	<b>Examiner</b> ANDREW JOSEPH RUDY	<b>Art Unit</b> 3687	<b>AIA (First Inventor to File) Status</b> No

**-- The MAILING DATE of this communication appears on the cover sheet with the correspondence address--**

All claims being allowable, PROSECUTION ON THE MERITS IS (OR REMAINS) CLOSED in this application. If not included herewith (or previously mailed), a Notice of Allowance (PTOL-85) or other appropriate communication will be mailed in due course. **THIS NOTICE OF ALLOWABILITY IS NOT A GRANT OF PATENT RIGHTS.** This application is subject to withdrawal from issue at the initiative of the Office or upon petition by the applicant. See 37 CFR 1.313 and MPEP 1308.

1.  This communication is responsive to the November 23, 2016 Amendment.  
 A declaration(s)/affidavit(s) under **37 CFR 1.130(b)** was/were filed on \_\_\_\_\_.
2.  An election was made by the applicant in response to a restriction requirement set forth during the interview on \_\_\_\_\_; the restriction requirement and election have been incorporated into this action.
3.  The allowed claim(s) is/are 1-47 and 49. As a result of the allowed claim(s), you may be eligible to benefit from the **Patent Prosecution Highway** program at a participating intellectual property office for the corresponding application. For more information, please see [http://www.uspto.gov/patents/init\\_events/pph/index.jsp](http://www.uspto.gov/patents/init_events/pph/index.jsp) or send an inquiry to [PPHfeedback@uspto.gov](mailto:PPHfeedback@uspto.gov).
4.  Acknowledgment is made of a claim for foreign priority under 35 U.S.C. § 119(a)-(d) or (f).

**Certified copies:**

- a)  All    b)  Some    \*c)  None of the:
1.  Certified copies of the priority documents have been received.
  2.  Certified copies of the priority documents have been received in Application No. \_\_\_\_\_.
  3.  Copies of the certified copies of the priority documents have been received in this national stage application from the International Bureau (PCT Rule 17.2(a)).

\* Certified copies not received: \_\_\_\_\_.

Applicant has THREE MONTHS FROM THE "MAILING DATE" of this communication to file a reply complying with the requirements noted below. Failure to timely comply will result in ABANDONMENT of this application.

**THIS THREE-MONTH PERIOD IS NOT EXTENDABLE.**

5.  CORRECTED DRAWINGS ( as "replacement sheets") must be submitted.  
 including changes required by the attached Examiner's Amendment / Comment or in the Office action of Paper No./Mail Date \_\_\_\_\_.  
**Identifying indicia such as the application number (see 37 CFR 1.84(c)) should be written on the drawings in the front (not the back) of each sheet. Replacement sheet(s) should be labeled as such in the header according to 37 CFR 1.121(d).**
6.  DEPOSIT OF and/or INFORMATION about the deposit of BIOLOGICAL MATERIAL must be submitted. Note the attached Examiner's comment regarding REQUIREMENT FOR THE DEPOSIT OF BIOLOGICAL MATERIAL.

**Attachment(s)**

- |  |   |
|--|---|
| <ol style="list-style-type: none"> <li>1. <input checked="" type="checkbox"/> Notice of References Cited (PTO-892)</li> <li>2. <input checked="" type="checkbox"/> Information Disclosure Statements (PTO/SB/08),<br/>Paper No./Mail Date _____</li> <li>3. <input type="checkbox"/> Examiner's Comment Regarding Requirement for Deposit<br/>of Biological Material</li> <li>4. <input type="checkbox"/> Interview Summary (PTO-413),<br/>Paper No./Mail Date _____.</li> </ol> | <ol style="list-style-type: none"> <li>5. <input checked="" type="checkbox"/> Examiner's Amendment/Comment</li> <li>6. <input checked="" type="checkbox"/> Examiner's Statement of Reasons for Allowance</li> <li>7. <input type="checkbox"/> Other _____.</li> </ol> |
|--|---|

--	--

**DETAILED ACTION**

***Notice of Pre-AIA or AIA Status***

1. The present application is being examined under the pre-AIA first to invent provisions.
2. Applicant cancelled claim 48.
3. Further pertinent references of interest are noted on the attached PTO-892.
4. Applicant's Information Disclosure Statement (IDS) submitted November 23, 2016 has been reviewed. Note the attached IDS.

***Allowable Subject Matter***

5. Claims 1-47 and 49 are allowed.
6. The following is an examiner's statement of reasons for allowance: Applicant's November 23, 2016 Amendment and REMARKS have been reviewed. Pursuant thereto, claims 1-47 and 49 are now allowed as the prior art, either alone or in combination, does not disclose Applicant's inventive claim language.

Claims 1-47 and 49 have been reviewed in light of Alice Corporation Pty. Ltd. v. CLS Bank International, et al., 573 U. S. \_\_\_\_ (2014) and are not deemed invalidated by such.

Claims 1-47 and 49 are determined to be directed to patent-eligible subject matter and the Examiner does not consider any of the pending claims to be directed to an abstract idea. Even if the Examiner were to identify an abstract idea for any claim, then under a further analysis under Alice all claims would still be found to be patent eligible for the following reasons. The Examiner finds that when all of the elements of each claim are considered individually and as an ordered combination, each claim contains an inventive concept which is directed to an application, a particular application, or a special application, of the identified abstract idea. Further the Examiner finds that issuance of a patent for any claim would not preempt the identified abstract idea, or the field of the identified abstract idea.

Any comments considered necessary by applicant must be submitted no later than the payment of the issue fee and, to avoid processing delays, should preferably accompany the issue fee. Such submissions should be clearly labeled "Comments on Statement of Reasons for Allowance."

7. Any inquiry concerning this communication or earlier communications from the examiner should be directed to ANDREW JOSEPH RUDY whose telephone number is (571)272-6789. The examiner can normally be reached on Monday thru Friday.

If attempts to reach the examiner by telephone are unsuccessful, the examiner's supervisor, Fahd A. Obeid can be reached on 571-270-3324. The fax phone number for the organization where this application or proceeding is assigned is 571-273-8300.

Information regarding the status of an application may be obtained from the Patent Application Information Retrieval (PAIR) system. Status information for published applications may be obtained from either Private PAIR or Public PAIR. Status information for unpublished applications is available through Private PAIR only. For more information about the PAIR system, see <http://pair-direct.uspto.gov>. Should you have questions on access to the Private PAIR system, contact the Electronic Business Center (EBC) at 866-217-9197 (toll-free). If you would like assistance from a USPTO Customer Service Representative or access to the automated information system, call 800-786-9199 (IN USA OR CANADA) or 571-272-1000.

/ANDREW JOSEPH RUDY/  
Primary Examiner  
Art Unit 3687

**IN THE UNITED STATES PATENT AND TRADEMARK OFFICE**

In re Application of: Raleigh et al.	Examiner: Rudy, Andrew J.
Serial No.: 14/208,236	Art Unit: 3687
Filed: March 13, 2014	Conf. No.: 1058
Title: Automated Credential Porting for Mobile Devices	

Mail Stop Amendment  
Commissioner for Patents  
P.O. Box 1450  
Alexandria, VA 22313-1450

**AMENDMENT AND RESPONSE**

In response to the Office Action dated August 23, 2016, the no-fee deadline for response being November 23, 2016, please amend the above-identified application as follows:

**Amendments to the Claims** begin on page 2.

**Remarks** begin on page 11.

AMENDMENTS TO THE CLAIMS

Without prejudice and without surrender of any subject matter, please amend the claims as follows:

1. (Currently Amended) A wireless device, comprising:

a user interface;

memory configured to store:

one or more credentials associated with the wireless device, the one or more credentials for ~~authorizing~~ ~~enabling~~ the wireless device to use ~~obtain one or more services over a wireless access network to access~~ one or more services, and

a target credential; and

one or more processors configured to execute one or more machine-executable instructions that, when executed by the one or more processors, cause the one or more processors to:

obtain, through the user interface, an indication of a user request to replace a particular credential of the one or more credentials with the target credential,

detect a network-provisioning state change, and

based on the detected network-provisioning state change, automatically determine that the particular credential does not match the target credential,

initiate a programming session with a network element communicatively coupled to the wireless device over the wireless access network,

obtain an updated credential from the network element, and assist in storing, in memory, the updated credential as the particular credential.

2. (Original) The wireless device recited in claim 1, wherein, when executed by the one or more processors, the one or more machine-executable instructions further cause the one or more processors to:
  - determine that the updated credential does not match the target credential, and
  - based on the determination that the updated credential does not match the target credential, take an action.
3. (Original) The wireless device recited in claim 2, wherein the action is to communicate with the network element.
4. (Original) The wireless device recited in claim 2, wherein the action is to cause a notification to be presented through the user interface, wherein the notification reports an error.
5. (Original) The wireless device recited in claim 2, wherein the action is to cause a notification to be presented through the user interface, wherein the notification reports that a procedure is in progress or has not been completed.
6. (Original) The wireless device recited in claim 2, wherein the action is to at least assist in restricting communications by the wireless device over the wireless access network.
7. (Original) The wireless device recited in claim 1, wherein, when executed by the one or more processors, the one or more machine-executable instructions further cause the one or more processors to:
  - determine that the updated credential matches the target credential, and
  - based on the determination that the updated credential matches the target credential, take an action.
8. (Original) The wireless device recited in claim 7, wherein the action is to cause a notification to be presented through the user interface, wherein the notification reports that the particular credential has been replaced by the target credential.

9. (Original) The wireless device recited in claim 1, wherein, when executed by the one or more processors, the one or more machine-executable instructions further cause the one or more processors to cause a notification to be presented through the user interface, the notification providing information about a status of the user request to replace the particular credential of the one or more credentials with the target credential.
10. (Original) The wireless device recited in claim 1, wherein, when executed by the one or more processors, the one or more machine-executable instructions further cause the one or more processors to cause a notification to be presented through the user interface, the notification requesting confirmation of the user request to replace the particular credential with the target credential.
11. (Original) The wireless device recited in claim 1, wherein detecting the network-provisioning state change comprises determining that a registration attempt initiated by the wireless device has failed.
12. (Original) The wireless device recited in claim 1, wherein detecting the network-provisioning state change comprises determining that an attempt by the wireless device to place a voice call has failed.
13. (Original) The wireless device recited in claim 1, wherein detecting the network-provisioning state change comprises determining that an attempt by the wireless device to send a text message has failed.
14. (Original) The wireless device recited in claim 1, wherein detecting the network-provisioning state change comprises determining that an attempt by the wireless device to authenticate with the network element has failed.

15. (Original) The wireless device recited in claim 1, wherein detecting the network-provisioning state change comprises determining that an attempt by the wireless device to be authorized for a service has failed.
16. (Original) The wireless device recited in claim 1, wherein detecting the network-provisioning state change comprises determining that a network access error has occurred.
17. (Original) The wireless device recited in claim 1, wherein detecting the network-provisioning state change comprises receiving a provisioning-state-change message.
18. (Original) The wireless device recited in claim 17, wherein the provisioning-state-change message comprises a text message.
19. (Original) The wireless device recited in claim 17, wherein the provisioning-state-change message comprises a push message from a push server communicatively coupled to the wireless device over the wireless access network.
20. (Original) The wireless device recited in claim 17, wherein the provisioning-state-change message comprises a message received by an application program on the wireless device.
21. (Original) The wireless device recited in claim 1, wherein the one or more credentials comprise a phone number.
22. (Original) The wireless device recited in claim 1, wherein the one or more credentials comprise an international mobile subscriber identifier (IMSI), a mobile station identifier (MSID), a mobile station international ISDN number (MSISDN), a subscriber information module (SIM) identifier, an electronic serial number (ESN), a mobile equipment identifier (MEID), an international mobile equipment identity (IMEI), a device identifier, a subscriber identifier, a service account identifier, a media access control (MAC) address, an Internet protocol (IP) address, a token, a one-time token, a

- mobile directory number (MDN), a network access identifier (NAI), a user name, a password, access point name (APN) configuration information, an encryption key (Ki), a Wi-Fi service set identifier (SSID), a Wi-Fi network configuration, an IP address, or a combination of these.
23. (Original) The wireless device recited in claim 1, wherein the target credential comprises a phone number.
24. (Original) The wireless device recited in claim 1, wherein the target credential comprises an international mobile subscriber identifier (IMSI), a mobile station identifier (MSID), a mobile station international ISDN number (MSISDN), a subscriber information module (SIM) identifier, an electronic serial number (ESN), a mobile equipment identifier (MEID), an international mobile equipment identity (IMEI), a device identifier, a subscriber identifier, a service account identifier, a media access control (MAC) address, an Internet protocol (IP) address, a token, a one-time token, a mobile directory number (MDN), a network access identifier (NAI), a user name, a password, access point name (APN) configuration information, an encryption key (Ki), a Wi-Fi service set identifier (SSID), a Wi-Fi network configuration, an IP address, or a combination of these.
25. (Original) The wireless device recited in claim 1, wherein the particular credential comprises a first phone number currently associated with the wireless device, and wherein the target credential comprises a second phone number.
26. (Currently Amended) The wireless device recited in claim 25, wherein the wireless device is a first wireless device, and wherein the second phone number is, prior to the user request to replace the particular credential with the target credential, associated with a second wireless device.
27. (Currently Amended) The wireless device recited in claim 25, wherein the second phone number is, prior to the user request to replace the particular credential with the target credential, associated with a land line.

28. (Original) The wireless device recited in claim 1, wherein the user interface comprises a display.
29. (Original) The wireless device recited in claim 1, wherein the user interface comprises a speaker.
30. (Original) The wireless device recited in claim 1, wherein the one or more services comprise a voice service, a messaging service, or a data service.
31. (Original) The wireless device recited in claim 1, wherein the one or more machine-executable instructions comprise an application program.
32. (Original) The wireless device recited in claim 1, wherein the one or more machine-executable instructions comprise an operating system (OS) component, an OS function, an OS service, a modem programming agent, a modem software or firmware agent, an over-the-air (OTA) mobile device parameter programming agent, an Open Mobile Alliance (OMA) agent, a secure communication agent configured to communicate number porting and number provisioning information, a software agent, a firmware agent, or a combination of these.
33. (Original) The wireless device recited in claim 1, wherein the user request comprises an indication of the target credential, a phone number, a user name, a password, an account number, a subscriber name, a company name, at least a portion of a billing address, at least a portion of a social security number, a personal identification number (PIN), or a combination of these.
34. (Original) The wireless device recited in claim 1, wherein obtaining the indication of the user request to replace the particular credential of the one or more credentials with the target credential comprises obtaining information from a website.

35. (Original) The wireless device recited in claim 1, wherein obtaining the indication of the user request to replace the particular credential of the one or more credentials with the target credential comprises obtaining information associated with the user request through the user interface.
36. (Original) The wireless device recited in claim 1, wherein the network element comprises a programming server.
37. (Original) The wireless device recited in claim 1, wherein initiating the programming session with the network element communicatively coupled to the wireless device over the wireless access network comprises contacting the network element using at least a portion of the one or more credentials associated with the wireless device.
38. (Original) The wireless device recited in claim 1, wherein initiating the programming session with the network element communicatively coupled to the wireless device over the wireless access network comprises contacting the network element using a temporary credential.
39. (Original) The wireless device recited in claim 38, wherein, when executed by the one or more processors, the one or more machine-executable instructions further cause the one or more processors to obtain the temporary credential from memory.
40. (Original) The wireless device recited in claim 38, wherein, when executed by the one or more processors, the one or more machine-executable instructions further cause the one or more processors to obtain the temporary credential from a network system communicatively coupled to the wireless device.
41. (Original) The wireless device recited in claim 1, wherein initiating the programming session with the network element communicatively coupled to the wireless device over the wireless access network comprises contacting the network element using a default credential.

42. (Original) The wireless device recited in claim 1, wherein initiating the programming session with the network element communicatively coupled to the wireless device over the wireless access network comprises communicating with the network element over the wireless access network.
43. (Original) The wireless device recited in claim 1, wherein initiating the programming session with the network element communicatively coupled to the wireless device over the wireless access network comprises communicating with the network element over a Wi-Fi network.
44. (Original) The wireless device recited in claim 1, wherein initiating the programming session with the network element communicatively coupled to the wireless device over the wireless access network comprises communicating with the network element through a voice call.
45. (Original) The wireless device recited in claim 1, wherein, when executed by the one or more processors, the one or more machine-executable instructions further cause the one or more processors to at least assist in restricting communications over the wireless access network until the updated credential has been obtained.
46. (Original) The wireless device recited in claim 1, wherein the target credential comprises a configuration state indicator.
47. (Currently Amended) A non-transitory computer-readable storage medium storing one or more machine-executable instructions that, when executed by one or more processors of a wireless device, cause the one or more processors to:
- obtain, through a user interface, an indication of a user request to replace a particular credential of one or more credentials, for authorizing the wireless device to use a wireless access network to access one or more services, with a target credential;

detect a network-provisioning state change; and  
based on the detected network-provisioning state change, automatically  
determine that the particular credential does not match the target  
credential[[;]],  
initiate a programming session with a network element communicatively  
coupled to the wireless device over a wireless access network[[;]],  
obtain an updated credential from the network element[[;]], and  
assist in storing, in memory, the updated credential as the particular credential.

48. (Canceled).

49. (New) The wireless device of claim 1, wherein the memory configured to store the one or more credentials comprises a protected memory that does not allow direct user modification of the particular credential.

REMARKS

Claims 1-47 are pending and were rejected by the Office Action dated August 23, 2016. Claim 48 was previously withdrawn and is canceled herein. Claims 1, 26, 27, and 47 are amended herein, and new claim 49 has been added. Accordingly, claims 1-47 and 49 are active in the application. In view of the claim amendments and the following remarks, Applicant respectfully requests reconsideration.

Comments on Claim Amendments

Applicant has made two changes to independent claims 1 and 47 to remove potential ambiguity in the prior claim formulations.

First, the original claim 1 phrase “the one or more credentials for enabling the wireless device to obtain one or more services over a wireless access network” is subject to at least two potentially reasonable interpretations. In a first interpretation, the credentials are necessary to obtain the services, which are incidentally accessed over a wireless access network (this appears to be the interpretation taken in the Office Action). In a second interpretation, the credentials are necessary for the device to specifically use the wireless access network to access the one or more services. Based on a review of the specification, the first interpretation was clearly not the one intended. Also, the first interpretation makes little sense when viewed with later claim elements that base credential update on a network-provisioning state change.

Accordingly, Applicant has amended claim 1 (and amended claim 47 similarly) to clarify “the one or more credentials for authorizing enabling the wireless device to use obtain one or more services over a wireless access network to access one or more services.” Applicant submits that all reasonable interpretations of this phrasing limit the credentials to those that a wireless device uses to gain authorization to use a wireless access network. Based on a service plan, policy, etc., the credentials may not authorize the access of all services over the wireless access network, but they authorize access to at least one service.

The second change to the independent claims clarifies that when the network-provisioning state change is detected, this automatically triggers the determination of a credential

mismatch, the initiation of a programming session, obtaining an updated credential, and assisting in storage of the credential in memory. As previously written, it was not clear that all these steps were automatically taken by the processor(s) executing instructions, in response to detecting the network-provisioning state change.

Finally, new claim 49 clarifies that the memory configured to store the one or more credentials is not modifiable by a user to change the particular credential. (See the specification at [0045]).

Each of the claim amendments discussed above is directly supported by the specification. No new matter has been added.

#### Claim Rejections – 35 U.S.C. § 103

In section 8, the Office Action rejected claims 1-47 under 35 U.S.C. § 103(a) as being unpatentable over U.S. 9,191,394 to Novak (hereinafter, “Novak”) in view of Official Notice taken by the Examiner. Applicant respectfully traverses this rejection on the grounds that the combination of Novak with the Official Notice fails to present a *prima facie* case of obviousness.

Novak discloses a networked credential service (Figure 4) that can store credentials that allow a user to access an “identity provider” (basically a web service that requires some sort of credential authentication before allowing user access to their account). The main feature of Novak’s credential service 400 with a user credential store 410 is that it stores credentials at a location other than the user’s computing device. Referring to Figure 3, the transfer of user credentials occurs between the credential service 306 and an identity provider 304 in a way in which the credentials aren’t even accessible by the computing device 302, much less stored there (secure session #2 transfers user credentials and uses security keys known only to identity provider 304 and credential service 306; see, e.g., Novak at col. 9, ll. 1-42, and more particularly ll. 22-27.)

The Official Notice states “the machine may be viewed as the computer device and credential service.” Applicant respectfully disagrees as this destroys the desirable features Novak teaches for the credential service, which are to get the credentials off a user’s device for

security, allow a single service to support many users, and allow each user to access the credentials from many devices. The other elements identified in the Official Notice may be known generally, but not with any particular relevant applicability to the claimed subject matter.

Turning now to the claim 1 and 47 language, it is clear that the types of credentials visualized by Novak are not “one or more credentials for authorizing the wireless device to use a wireless access network.” Note that Novak freely assumes network connectivity is available to reach both the credential service and the identity provider. Without such credentials already in place on the device itself, when the wireless access network is the only means available to access the Internet, there would be no way for the device to reach either the identity provider or the credential service. Thus Novak’s approach is inapplicable to the type of problem addressed by the present claims.

Novak and the Official Notice also fail to disclose wireless device processor execution to detect a network-provisioning state change and automatically take any steps in response, much less the particular automatic steps of claims 1 and 47 that result in the device determining the credential mismatch, initiating a programming session to obtain an updated credential, and assist in storing the updated credential as the particular credential.

Applicant submits that many of the dependent claims state further patentable advancements over the art, and include elements that Applicant could not locate in the applied reference. Applicant reserves the right to address such issues should a following Office Action more particularly address the dependent claims.

Based at least on the indicated lack of teaching of the elements of Applicant’s independent claims, Applicant requests that the obviousness rejection be withdrawn as to all claims.

CONCLUSION

Applicant respectfully requests entry of these amendments as provided herein. The application is believed to be in condition for allowance, and a Notice of Allowance is hereby respectfully requested. If the Examiner has any questions or needs any additional information, the Examiner is invited to contact the undersigned.

The Commissioner is authorized to charge any fee deficiency or credit any overpayment to Deposit Account 50-5876.

Respectfully submitted,

Date: November 23, 2016

By: /James E. Harris/

James E. Harris  
Reg. No. 40,013  
Patent Counsel  
Headwater Partners I LLC  
1011 Pruitt Place  
Tyler, TX 75703  
(903) 201-6212

CERTIFICATE OF ELECTRONIC TRANSMISSION

I hereby certify that this paper (along with any paper referred to as being attached or enclosed) is being filed electronically via EFS-Web addressed to the Commissioner for Patents on:

Date: Nov. 23, 2016

By: /Ann Taylor/  
Ann Taylor



UNITED STATES PATENT AND TRADEMARK OFFICE

UNITED STATES DEPARTMENT OF COMMERCE
United States Patent and Trademark Office
Address: COMMISSIONER FOR PATENTS
P.O. Box 1450
Alexandria, Virginia 22313-1450
www.uspto.gov

Table with columns: APPLICATION NO., FILING DATE, FIRST NAMED INVENTOR, ATTORNEY DOCKET NO., CONFIRMATION NO. Includes application details for Gregory G. Raleigh and examination information for RUDY, ANDREW J.

Please find below and/or attached an Office communication concerning this application or proceeding.

The time period for reply, if any, is set in the attached communication.

Notice of the Office communication was sent electronically on above-indicated "Notification Date" to the following e-mail address(es):

patent@headwaterllc.com
krista@jacobseniplaw.com

<b>Office Action Summary</b>	<b>Application No.</b> 14/208,236	<b>Applicant(s)</b> RALEIGH ET AL.	
	<b>Examiner</b> ANDREW JOSEPH RUDY	<b>Art Unit</b> 3687	<b>AIA (First Inventor to File) Status</b> No

-- The MAILING DATE of this communication appears on the cover sheet with the correspondence address --

**Period for Reply**

A SHORTENED STATUTORY PERIOD FOR REPLY IS SET TO EXPIRE 3 MONTHS FROM THE MAILING DATE OF THIS COMMUNICATION.

- Extensions of time may be available under the provisions of 37 CFR 1.136(a). In no event, however, may a reply be timely filed after SIX (6) MONTHS from the mailing date of this communication.
- If NO period for reply is specified above, the maximum statutory period will apply and will expire SIX (6) MONTHS from the mailing date of this communication.
- Failure to reply within the set or extended period for reply will, by statute, cause the application to become ABANDONED (35 U.S.C. § 133). Any reply received by the Office later than three months after the mailing date of this communication, even if timely filed, may reduce any earned patent term adjustment. See 37 CFR 1.704(b).

**Status**

- 1)  Responsive to communication(s) filed on 08 June 2016.  
 A declaration(s)/affidavit(s) under **37 CFR 1.130(b)** was/were filed on \_\_\_\_\_.
- 2a)  This action is **FINAL**.                      2b)  This action is non-final.
- 3)  An election was made by the applicant in response to a restriction requirement set forth during the interview on \_\_\_\_\_; the restriction requirement and election have been incorporated into this action.
- 4)  Since this application is in condition for allowance except for formal matters, prosecution as to the merits is closed in accordance with the practice under *Ex parte Quayle*, 1935 C.D. 11, 453 O.G. 213.

**Disposition of Claims\***

- 5)  Claim(s) 1-48 is/are pending in the application.  
5a) Of the above claim(s) 48 is/are withdrawn from consideration.
- 6)  Claim(s) \_\_\_\_\_ is/are allowed.
- 7)  Claim(s) 1-47 is/are rejected.
- 8)  Claim(s) \_\_\_\_\_ is/are objected to.
- 9)  Claim(s) \_\_\_\_\_ are subject to restriction and/or election requirement.

\* If any claims have been determined allowable, you may be eligible to benefit from the **Patent Prosecution Highway** program at a participating intellectual property office for the corresponding application. For more information, please see [http://www.uspto.gov/patents/init\\_events/pph/index.jsp](http://www.uspto.gov/patents/init_events/pph/index.jsp) or send an inquiry to [PPHfeedback@uspto.gov](mailto:PPHfeedback@uspto.gov).

**Application Papers**

- 10)  The specification is objected to by the Examiner.
- 11)  The drawing(s) filed on \_\_\_\_\_ is/are: a)  accepted or b)  objected to by the Examiner.  
Applicant may not request that any objection to the drawing(s) be held in abeyance. See 37 CFR 1.85(a).  
Replacement drawing sheet(s) including the correction is required if the drawing(s) is objected to. See 37 CFR 1.121(d).

**Priority under 35 U.S.C. § 119**

- 12)  Acknowledgment is made of a claim for foreign priority under 35 U.S.C. § 119(a)-(d) or (f).

**Certified copies:**

- a)  All    b)  Some\*\*    c)  None of the:
1.  Certified copies of the priority documents have been received.
  2.  Certified copies of the priority documents have been received in Application No. \_\_\_\_\_.
  3.  Copies of the certified copies of the priority documents have been received in this National Stage application from the International Bureau (PCT Rule 17.2(a)).

\*\* See the attached detailed Office action for a list of the certified copies not received.

**Attachment(s)**

- 1)  Notice of References Cited (PTO-892)
- 2)  Information Disclosure Statement(s) (PTO/SB/08a and/or PTO/SB/08b)  
Paper No(s)/Mail Date \_\_\_\_\_.
- 3)  Interview Summary (PTO-413)  
Paper No(s)/Mail Date. \_\_\_\_\_.
- 4)  Other: \_\_\_\_\_.

### **DETAILED ACTION**

1. The present application is being examined under the pre-AIA first to invent provisions.

### ***Election/Restrictions***

2. Claim 48 is withdrawn from further consideration pursuant to 37 CFR 1.142(b) as being drawn to a nonelected invention, there being no allowable generic or linking claim. Election was made **without** traverse in the reply filed on June 8, 2016.

### ***Claim Rejections - 35 USC § 101***

3. Claims 1-47 have been reviewed in light of Alice Corporation Pty. Ltd. v. CLS Bank International, et al., 573 U. S. \_\_\_\_ (2014). In short, Applicant's claims are not deemed adversely impacted by the "Alice" decision. Thus, a "101" rejection is not deemed warranted.

### ***Claim Rejections - 35 USC § 103***

7. The following is a quotation of pre-AIA 35 U.S.C. 103(a) which forms the basis for all obviousness rejections set forth in this Office action:

(a) A patent may not be obtained though the invention is not identically disclosed or described as set forth in section 102 of this title, if the differences between the subject matter sought to be patented and the prior art are such that the subject matter as a whole would have been obvious at the time the invention was made to a person having ordinary skill in the art to which said subject matter pertains. Patentability shall not be negated by the manner in which the invention was made.

8. Claims 1-47 are rejected under pre-AIA 35 U.S.C. 103(a) as being unpatentable over Novak et al., US 9,191,394.

Novak discloses, e.g. Figs. 1-8 and related text, a wireless device, e.g. Fig. 1, having a user interface, e.g. 402, a memory, e.g. 804, a computer device, e.g. 800, including one or more processors, servers, e.g. 160, a provider identifier, e.g. 414, a credential service, e.g. 106, having multiple credentials, e.g. a phone number, 412, that may be updated, that are used to see if they match depending upon the state of a network, and a website, e.g. 134. Novak does not specifically disclose the terms machine-executable instructions associated with a particular credential, nor an error report, nor a land line.

Official Notice is taken that a particular credential, that may be updated, associated with a particular client using a wireless device has been common knowledge within the wireless communication network art. The machine may be viewed as the computer device and credential service. Also, error reports associated with data transfers have been common knowledge in the art, as are wireless devices placing a voice call associated with land lines. To have provided such for Novak would have been obvious to one of ordinary skill in the art in view of Official Notice. Motivation for providing such would have been to incorporate common knowledge wireless network technology associated with the type of data one desires to access and/or communicate with other users, while monitoring usage of such data.

9. Further pertinent references of interest are noted on the attached PTO-892.

10. Applicant's fourteen (14) Information Disclosure Statements (IDS's) have been reviewed. Note the attached IDS's.

11. Any inquiry concerning this communication or earlier communications from the examiner should be directed to ANDREW JOSEPH RUDY whose telephone number is (571)272-6789. The examiner can normally be reached on Monday thru Friday.

If attempts to reach the examiner by telephone are unsuccessful, the examiner's supervisor, Fahd A. Obeid can be reached on 571-270-3324. The fax phone number for the organization where this application or proceeding is assigned is 571-273-8300.

Information regarding the status of an application may be obtained from the Patent Application Information Retrieval (PAIR) system. Status information for published applications may be obtained from either Private PAIR or Public PAIR. Status information for unpublished applications is available through Private PAIR only. For more information about the PAIR system, see <http://pair-direct.uspto.gov>. Should you have questions on access to the Private PAIR system, contact the Electronic Business Center (EBC) at 866-217-9197 (toll-free). If you would like assistance from a USPTO Customer Service Representative or access to the automated information system, call 800-786-9199 (IN USA OR CANADA) or 571-272-1000.

/ANDREW JOSEPH RUDY/

Primary Examiner, Art Unit 3687

**IN THE UNITED STATES PATENT AND TRADEMARK OFFICE**

In re Application of: Raleigh et al.	Examiner: Rudy, Andrew J.
Serial No.: 14/208,236	Art Unit: 3687
Filed: March 13, 2014	Conf. No.: 1058
Title: Automated Credential Porting for Mobile Devices	

Mail Stop Amendment  
Commissioner for Patents  
P.O. Box 1450  
Alexandria, VA 22313-1450

**RESPONSE TO RESTRICTION REQUIREMENT**

In response to the Restriction Requirement dated May 11, 2016, the deadline for response being July 11, 2016, Applicant elects claims 1-47 (Group I), without traverse. If the Examiner has any questions or needs any additional information, the Examiner is invited to contact the undersigned.

Respectfully submitted,

Date: June 8, 2016

By: /James E. Harris/

James E. Harris  
Reg. No. 40,013  
Patent Counsel  
Headwater Partners I LLC  
1011 Pruitt Place  
Tyler, TX 75703  
(903) 201-6212

**CERTIFICATE OF ELECTRONIC TRANSMISSION**

I hereby certify that this paper (along with any paper referred to as being attached or enclosed) is being filed electronically via EFS-Web addressed to the Commissioner for Patents on:

Date: June 8, 2016 By: /Ann Taylor/  
Ann Taylor



UNITED STATES PATENT AND TRADEMARK OFFICE

UNITED STATES DEPARTMENT OF COMMERCE
United States Patent and Trademark Office
Address: COMMISSIONER FOR PATENTS
P. O. Box 1450
Alexandria, Virginia 22313-1450
www.uspto.gov

Table with columns: APPLICATION NO., FILING DATE, FIRST NAMED INVENTOR, ATTORNEY DOCKET NO., CONFIRMATION NO., EXAMINER, ART UNIT, PAPER NUMBER, NOTIFICATION DATE, DELIVERY MODE. Includes application details for Gregory G. Raleigh and Headwater Partners I LLC.

Please find below and/or attached an Office communication concerning this application or proceeding.

The time period for reply, if any, is set in the attached communication.

Notice of the Office communication was sent electronically on above-indicated "Notification Date" to the following e-mail address(es):

patent@headwaterllc.com
krista@jacobseniplaw.com



**DETAILED ACTION**

***Notice of Pre-AIA or AIA Status***

1. The present application is being examined under the pre-AIA first to invent provisions.

***Election/Restrictions***

2. Restriction to one of the following inventions is required under 35 U.S.C. 121:
  - I. Claims 1-47, drawn to a device/medium, classified in 455/411.
  - II. Claim 48, drawn to a method, classified in 709/223.
  
3. The inventions are distinct, each from the other because of the following reasons:

Inventions Group II and Group I are related as process and apparatus for its practice. The inventions are distinct if it can be shown that either: (1) the process as claimed can be practiced by another and materially different apparatus or by hand, or (2) the apparatus as claimed can be used to practice another and materially different process. (MPEP § 806.05(e)). In this case the process may be practiced by a different apparatus that does not include one or more services as recited from Group II.
  
5. Restriction for examination purposes as indicated is proper because all these inventions listed in this action are independent or distinct for the reasons given above and there would be a serious search and/or examination burden if restriction were not required because one or more of the following reasons apply:

The apparatus may be practiced by a materially different process.

**Applicant is advised that the reply to this requirement to be complete must include (i) an election of an invention to be examined even though the requirement may be traversed (37 CFR 1.143) and (ii) identification of the claims encompassing the elected invention.**

The election of an invention may be made with or without traverse. To reserve a right to petition, the election must be made with traverse. If the reply does not distinctly and specifically point out supposed errors in the restriction requirement, the election shall be treated as an election without traverse. Traversal must be presented at the time of election in order to be considered timely. Failure to timely traverse the requirement will result in the loss of right to petition under 37 CFR 1.144. If claims are added after the election, applicant must indicate which of these claims are readable upon the elected invention.

Should applicant traverse on the ground that the inventions are not patentably distinct, applicant should submit evidence or identify such evidence now of record showing the inventions to be obvious variants or clearly admit on the record that this is the case. In either instance, if the examiner finds one of the inventions unpatentable over the prior art, the evidence or admission may be used in a rejection under 35 U.S.C. 103 or pre-AIA 35 U.S.C. 103(a) of the other invention.

6. The examiner has required restriction between product or apparatus claims and process claims. Where applicant elects claims directed to the product/apparatus, and all

considered for rejoinder. All claims directed to a nonelected process invention must include all the limitations of an allowable product/apparatus claim for that process invention to be rejoined.

In the event of rejoinder, the requirement for restriction between the product/apparatus claims and the rejoined process claims will be withdrawn, and the rejoined process claims will be fully examined for patentability in accordance with 37 CFR 1.104. Thus, to be allowable, the rejoined claims must meet all criteria for patentability including the requirements of 35 U.S.C. 101, 102, 103 and 112. Until all claims to the elected product/apparatus are found allowable, an otherwise proper restriction requirement between product/apparatus claims and process claims may be maintained. Withdrawn process claims that are not commensurate in scope with an allowable product/apparatus claim will not be rejoined. See MPEP § 821.04. Additionally, in order for rejoinder to occur, applicant is advised that the process claims should be amended during prosecution to require the limitations of the product/apparatus claims. **Failure to do so may result in no rejoinder.** Further, note that the prohibition against double patenting rejections of 35 U.S.C. 121 does not apply where the restriction requirement is withdrawn by the examiner before the patent issues. See MPEP § 804.01.

7. A telephone call was made to James Harris (Reg. No. 40,013) on May 2, 2016 to request an oral election to the above restriction requirement, but did not result in an election being made.

8. Any inquiry concerning this communication or earlier communications from the examiner should be directed to ANDREW JOSEPH RUDY whose telephone number is (571)272-6789. The examiner can normally be reached on Monday thru Friday.

Information regarding the status of an application may be obtained from the Patent Application Information Retrieval (PAIR) system. Status information for published applications may be obtained from either Private PAIR or Public PAIR. Status information for unpublished applications is available through Private PAIR only. For more information about the PAIR system, see <http://pair-direct.uspto.gov>. Should you have questions on access to the Private PAIR system, contact the Electronic Business Center (EBC) at 866-217-9197 (toll-free). If you would like assistance from a USPTO Customer Service Representative or access to the automated information system, call 800-786-9199 (IN USA OR CANADA) or 571-272-1000.

/ANDREW JOSEPH RUDY/

Primary Examiner

Art Unit 3687

APPLICATION FOR UNITED STATES PATENT

**AUTOMATED CREDENTIAL PORTING FOR MOBILE DEVICES**

By Inventor(s):

Gregory G. Raleigh  
Woodside, CA  
A Citizen of the United States

James Lavine  
Corte Madera, CA  
A Citizen of the United States

Assignee: Headwater Partners I LLC

HEADWATER PARTNERS I LLC  
350 Marine Parkway, Suite 300  
Redwood Shores, CA 94065  
Telephone (650) 517-2798

## **CROSS REFERENCE TO OTHER APPLICATIONS**

**[0001]** This application claims the benefit of U.S. Provisional Application No. 61/785,988 (Attorney Docket No. RALEP115+), filed March 14, 2013, entitled AUTOMATED CREDENTIAL PORTING FOR MOBILE DEVICES, which is hereby incorporated by reference for all purposes.

**[0002]** This document incorporates by reference for all purposes the following non-provisional U.S. patent applications: U.S. Application No. 12/380,780 (Attorney Docket No. RALEP007), filed March 2, 2009, entitled AUTOMATED DEVICE PROVISIONING AND ACTIVATION; U.S. Application No. 12/695,019 (Attorney Docket No. RALEP022), filed January 27, 2010, entitled DEVICE ASSISTED CDR CREATION, AGGREGATION, MEDIATION AND BILLING, now U.S. Patent No. 8,275,830 (issued September 25, 2012); U.S. Application No. 12/695,020 (Attorney Docket No. RALEP024), filed January 27, 2010, entitled ADAPTIVE AMBIENT SERVICES; U.S. Application No. 12/694,445 (Attorney Docket No. RALEP025), filed January 27, 2010, entitled SECURITY TECHNIQUES FOR DEVICE ASSISTED SERVICES, now U.S. Patent No. 8,391,834 (issued March 5, 2013); U.S. Application No. 12/694,451 (Attorney Docket No. RALEP026), filed January 27, 2010, entitled DEVICE GROUP PARTITIONS AND SETTLEMENT PLATFORM; U.S. Application No. 12/694,455 (Attorney Docket No. RALEP027), filed January 27, 2010, entitled DEVICE ASSISTED SERVICES INSTALL; U.S. Application No. 12/695,021 (Attorney Docket No. RALEP029), filed January 27, 2010, entitled QUALITY OF SERVICE FOR DEVICE ASSISTED SERVICES, now U.S. Patent No. 8,346,225 (issued January 1, 2013); U.S. Application No. 12/695,980 (Attorney Docket No. RALEP030), filed January 28, 2010, entitled ENHANCED ROAMING SERVICES AND CONVERGED CARRIER NETWORKS WITH DEVICE ASSISTED SERVICES AND A PROXY, now U.S. Patent No. 8,340,634 (issued December 25, 2012); U.S. Application No. 13/134,028 (Attorney Docket No. RALEP032), filed May 25, 2011, entitled DEVICE-ASSISTED SERVICES FOR PROTECTING NETWORK CAPACITY; U.S. Application No. 13/229,580 (Attorney Docket No. RALEP033), filed September 9, 2011, entitled WIRELESS NETWORK SERVICE INTERFACES; U.S. Application No. 13/237,827 (Attorney Docket No. RALEP034), filed September 20, 2011,

entitled ADAPTING NETWORK POLICIES BASED ON DEVICE SERVICE PROCESSOR CONFIGURATION; U.S. Application No. 13/253,013 (Attorney Docket No. RALEP035), filed October 4, 2011, entitled SYSTEM AND METHOD FOR PROVIDING USER NOTIFICATIONS; U.S. Application No. 13/239,321 (Attorney Docket No. RALEP036), filed September 21, 2011, entitled SERVICE OFFER SET PUBLISHING TO DEVICE AGENT WITH ON-DEVICE SERVICE SELECTION; U.S. Application No. 13/248,028 (Attorney Docket No. RALEP037), filed September 28, 2011, entitled ENTERPRISE ACCESS CONTROL AND ACCOUNTING ALLOCATION FOR ACCESS NETWORKS; U.S. Application No. 13/247,998 (Attorney Docket No. RALEP038), filed September 28, 2011, entitled SECURE DEVICE DATA RECORDS; U.S. Application No. 13/309,556 (Attorney Docket No. RALEP040), filed December 1, 2011, entitled END USER DEVICE THAT SECURES AN ASSOCIATION OF APPLICATION TO SERVICE POLICY WITH AN APPLICATION CERTIFICATE CHECK; U.S. Application No. 13/309,463 (Attorney Docket No. RALEP041), filed December 1, 2011, entitled SECURITY, FRAUD DETECTION, AND FRAUD MITIGATION IN DEVICE-ASSISTED SERVICES SYSTEMS; U.S. Application No. 13/248,025 (Attorney Docket No. RALEP043), filed September 28, 2011, entitled SERVICE DESIGN CENTER FOR DEVICE ASSISTED SERVICES; and U.S. Application No. 13/374,959 (Attorney Docket No. RALEP046), filed January 24, 2012, entitled FLOW TAGGING FOR SERVICE POLICY IMPLEMENTATION; U.S. Application No. 13/441,821 (Attorney Docket No. RALEP047A), filed April 6, 2012, entitled MANAGING SERVICE USER DISCOVERY AND SERVICE LAUNCH OBJECT PLACEMENT ON A DEVICE; U.S. Application No. 13/134,005 (Attorney Docket No. RALEP049), filed May 25, 2011, entitled SYSTEM AND METHOD FOR WIRELESS NETWORK OFFLOADING; U.S. Application No. 13/802,483 (Attorney Docket No. RALEP063), filed March 13, 2013, entitled MOBILE DEVICE ACTIVATION VIA DYNAMICALLY SELECTED ACCESS NETWORK; U.S. Application No. 13/842,172 (Attorney Docket No. RALEP104), filed March 15, 2013, entitled NETWORK SERVICE PLAN DESIGN; and U.S. Application No. 13/748,152 (Attorney Docket No. RALEP106), filed January 23, 2013, entitled SERVICE PLAN DESIGN, USER INTERFACES, APPLICATION PROGRAMMING INTERFACES, AND DEVICE MANAGEMENT.

**[0003]** This document incorporates by reference for all purposes the following provisional patent applications: U.S. Provisional Application No. 61/206,354 (Attorney Docket No. RALEP001+), filed January 28, 2009, entitled SERVICES POLICY COMMUNICATION SYSTEM AND METHOD; U.S. Provisional Application No. 61/206,944 (Attorney Docket No. RALEP002+), filed February 4, 2009, entitled SERVICES POLICY COMMUNICATION SYSTEM AND METHOD; U.S. Provisional Application No. 61/207,393 (Attorney Docket No. RALEP003+), filed February 10, 2009, entitled SERVICES POLICY COMMUNICATION SYSTEM AND METHOD; and U.S. Provisional Application No. 61/207,739 (Attorney Docket No. RALEP004+), entitled SERVICES POLICY COMMUNICATION SYSTEM AND METHOD, filed February 13, 2009; U.S. Provisional Application No. 61/270,353 (Attorney Docket No. RALEP022+), filed on July 6, 2009, entitled DEVICE ASSISTED CDR CREATION, AGGREGATION, MEDIATION AND BILLING; U.S. Provisional Application No. 61/275,208 (Attorney Docket No. RALEP023+), filed August 25, 2009, entitled ADAPTIVE AMBIENT SERVICES; and U.S. Provisional Application No. 61/237,753 (Attorney Docket No. RALEP024+), filed August 28, 2009, entitled ADAPTIVE AMBIENT SERVICES; U.S. Provisional Application No. 61/252,151 (Attorney Docket No. RALEP025+), filed October 15, 2009, entitled SECURITY TECHNIQUES FOR DEVICE ASSISTED SERVICES; U.S. Provisional Application No. 61/252,153 (Attorney Docket No. RALEP026+), filed October 15, 2009, entitled DEVICE GROUP PARTITIONS AND SETTLEMENT PLATFORM; U.S. Provisional Application No. 61/264,120 (Attorney Docket No. RALEP027+), filed November 24, 2009, entitled DEVICE ASSISTED SERVICES INSTALL; U.S. Provisional Application No. 61/264,126 (Attorney Docket No. RALEP028+), filed November 24, 2009, entitled DEVICE ASSISTED SERVICES ACTIVITY MAP; U.S. Provisional Application No. 61/348,022 (Attorney Docket No. RALEP031+), filed May 25, 2010, entitled DEVICE ASSISTED SERVICES FOR PROTECTING NETWORK CAPACITY; U.S. Provisional Application No. 61/381,159 (Attorney Docket No. RALEP032+), filed September 9, 2010, entitled DEVICE ASSISTED SERVICES FOR PROTECTING NETWORK CAPACITY; U.S. Provisional Application No. 61/381,162 (Attorney Docket No. RALEP033+), filed September 9, 2010, entitled SERVICE CONTROLLER INTERFACES AND WORKFLOWS; U.S. Provisional Application No. 61/384,456 (Attorney Docket No. RALEP034+), filed September 20, 2010, entitled SECURING SERVICE PROCESSOR WITH SPONSORED SIMS; U.S.

Provisional Application No. 61/389,547 (Attorney Docket No. RALEP035+), filed October 4, 2010, entitled USER NOTIFICATIONS FOR DEVICE ASSISTED SERVICES; U.S.

Provisional Application No. 61/385,020 (Attorney Docket No. RALEP036+), filed September 21, 2010, entitled SERVICE USAGE RECONCILIATION SYSTEM OVERVIEW; U.S.

Provisional Application No. 61/387,243 (Attorney Docket No. RALEP037+), filed September 28, 2010, entitled ENTERPRISE AND CONSUMER BILLING ALLOCATION FOR WIRELESS COMMUNICATION DEVICE SERVICE USAGE ACTIVITIES; U.S. Provisional Application No. 61/387,247 (Attorney Docket No. RALEP038+), filed September 28, entitled SECURED DEVICE DATA RECORDS, 2010; U.S. Provisional Application No. 61/407,358 (Attorney Docket No. RALEP039+), filed October 27, 2010, entitled SERVICE CONTROLLER AND SERVICE PROCESSOR ARCHITECTURE; U.S. Provisional Application No. 61/418,507 (Attorney Docket No. RALEP040+), filed December 1, 2010, entitled APPLICATION SERVICE PROVIDER INTERFACE SYSTEM; U.S. Provisional Application No. 61/418,509 (Attorney Docket No. RALEP041+), filed December 1, 2010, entitled SERVICE USAGE REPORTING RECONCILIATION AND FRAUD DETECTION FOR DEVICE ASSISTED SERVICES; U.S. Provisional Application No. 61/420,727 (Attorney Docket No. RALEP042+), filed December 7, 2010, entitled SECURE DEVICE DATA RECORDS; U.S. Provisional Application No. 61/422,565 (Attorney Docket No. RALEP043+), filed December 13, 2010, entitled SERVICE DESIGN CENTER FOR DEVICE ASSISTED SERVICES; U.S. Provisional Application No. 61/422,572 (Attorney Docket No. RALEP044+), filed December 13, 2010, entitled SYSTEM INTERFACES AND WORKFLOWS FOR DEVICE ASSISTED SERVICES; U.S. Provisional Application No. 61/422,574 (Attorney Docket No. RALEP045+), filed December 13, 2010, entitled SECURITY AND FRAUD DETECTION FOR DEVICE ASSISTED SERVICES; U.S. Provisional Application No. 61/435,564 (Attorney Docket No. RALEP046+), filed January 24, 2011, entitled FRAMEWORK FOR DEVICE ASSISTED SERVICES; U.S. Provisional Application No. 61/472,606 (Attorney Docket No. RALEP047+), filed April 6, 2011, entitled MANAGING SERVICE USER DISCOVERY AND SERVICE LAUNCH OBJECT PLACEMENT ON A DEVICE; U.S. Provisional Application No. 61/550,906 (Attorney Docket No. RALEP048+), filed October 24, 2011, entitled SECURITY FOR DEVICE-ASSISTED SERVICES; U.S. Provisional Application No. 61/589,830 (Attorney Docket No. RALEP052+), filed January 23, 2012, entitled METHODS AND APPARATUS TO

PRESENT INFORMATION ABOUT VOICE, MESSAGING, AND DATA SERVICES ON WIRELESS MOBILE DEVICES; U.S. Provisional Application No. 61/610,876 (Attorney Docket No. RALEP062+), filed March 14, 2012, entitled METHODS AND APPARATUS FOR APPLICATION PROMOTION AND SPONSORSHIP; U.S. Provisional Application No. 61/610,910 (Attorney Docket No. RALEP063+), filed March 14, 2012, entitled WIFI ACTIVATION BACKUP PROCESS; U.S. Provisional Application No. 61/658,339 (Attorney Docket No. RALEP100+), filed June 11, 2012, entitled MULTI-DEVICE MASTER SERVICES ACCOUNTS, SERVICE PLAN SHARING AND ASSIGNMENTS, AND DEVICE MANAGEMENT FROM A MASTER DEVICE; U.S. Provisional Application No. 61/667,927 (Attorney Docket No. RALEP101+), filed July 3, 2012, entitled FLEXIBLE MULTI-DEVICE MASTER SERVICE ACCOUNTS, SERVICE PLAN SHARING AND ASSIGNMENTS, AND DEVICE MANAGEMENT; U.S. Provisional Application No. 61/674,331 (Attorney Docket No. RALEP102+), filed July 21, 2012, entitled SERVICE CONTROLLER FOR MANAGING CLOUD-BASED POLICY; U.S. Provisional Application No. 61/724,267 (Attorney Docket No. RALEP106+), filed November 8, 2012, entitled FLEXIBLE SERVICE PLAN DESIGN, USER INTERFACE AND DEVICE MANAGEMENT; U.S. Provisional Application No. 61/724,837 (Attorney Docket No. RALEP107+), filed November 9, 2012, entitled SERVICE PLAN DISCOVERY, CUSTOMIZATION, AND MANAGEMENT; U.S. Provisional Application No. 61/724,974 (Attorney Docket No. RALEP108+), filed November 10, 2012, entitled SERVICE PLAN DISCOVERY, CUSTOMIZATION, AND MANAGEMENT; U.S. Provisional Application No. 61/732,249 (Attorney Docket No. RALEP109+), filed November 30, 2012, entitled APPLICATION PROGRAMMING INTERFACES FOR SMART SERVICES; U.S. Provisional Application No. 61/734,288 (Attorney Docket No. RALEP110+), filed December 6, 2012, entitled INTERMEDIATE NETWORKING DEVICE SERVICES; and U.S. Provisional Application No. 61/745,548 (Attorney Docket No. RALEP111+), filed December 22, 2012, entitled SERVICE PLAN DESIGN, USER INTERFACES, APPLICATION PROGRAMMING INTERFACES, AND DEVICE MANAGEMENT; U.S. Provisional Application No. 61/756,332 (Attorney Docket No. RALEP112+), filed January 24, 2013, entitled MOBILE HOTSPOT; U.S. Provisional Application No. 61/758,964 (Attorney Docket No. RALEP113+), filed January 30, 2013, entitled MOBILE HOTSPOT; U.S. Provisional Application No. 61/765,978 (Attorney Docket No. RALEP114+), filed February 18, 2013, entitled ENHANCED CURFEW AND

PROTECTION ASSOCIATED WITH A DEVICE GROUP; U.S. Provisional Application No. 61/794,116 (Attorney Docket No. RALEP116+), filed March 15, 2013, entitled ENHANCED INTERMEDIATE NETWORKING DEVICE; U.S. Provisional Application No. 61/792,765 (Attorney Docket No. RALEP117+), filed March 15, 2013, entitled DEVICE GROUP AND SERVICE PLAN MANAGEMENT; U.S. Provisional Application No. 61/793,894 (Attorney Docket No. RALEP118+), filed March 15, 2013, entitled SIMPLIFIED POLICY DESIGN, MANAGEMENT, AND IMPLEMENTATION; U.S. Provisional Application No. 61/799,710 (Attorney Docket No. RALEP119+), filed March 15, 2013, entitled AMBIENT OR SPONSORED SERVICES; and U.S. Provisional Application No. 61/801,074 (Attorney Docket No. RALEP120+), filed March 15, 2013, entitled DEVICE GROUP AND SERVICE PLAN MANAGEMENT.

## **BACKGROUND**

**[0004]** With the advent of mass-market wireless mobile devices and subscription wireless services, there are an increasing number of instances in which a mobile device user who has subscribed to a service provided by a service provider will stop using one device in favor of a new or otherwise different device, or stop his or her subscription with one service provider in favor of subscribing with another service provider. It is often the case that when a subscriber obtains a new device or moves from one service provider to another, the subscriber wishes to remain associated with the same phone number he or she has been using.

## **BRIEF DESCRIPTION OF THE DRAWINGS**

**[0005]** Objects, features, and advantages of the present disclosure will be more clearly understood from the following detailed description taken in conjunction with the accompanying drawings, in which:

**[0006]** FIG. 1 illustrates components of a wireless network architecture in accordance with some embodiments.

**[0007]** FIG. 2 illustrates components of a mobile device in accordance with some embodiments.

**[0008]** FIG. 3 illustrates a flow diagram for updating one or more credentials of a mobile device in accordance with some embodiments.

**[0009]** FIG. 4 illustrates an exemplary screen including a mechanism to request a new phone number or initiate a phone number transfer request from the device.

**[0010]** FIG. 5 illustrates an exemplary number management screen displayed when a user selects the “Transfer” region of FIG. 4.

**[0011]** FIG. 6 illustrates an exemplary screen displaying a notification listing the information to complete a phone number transfer.

**[0012]** FIGS. 7A and 7B illustrate an exemplary screens for entering account information to complete a phone number transfer.

**[0013]** FIG. 8 illustrates an exemplary screen requesting confirmation from the user to initiate the phone number transfer request.

**[0014]** FIG. 9 illustrates an exemplary screen displaying a notification that the number transfer request has been initiated.

**[0015]** FIG. 10 illustrates an exemplary screen displaying a notification that the number transfer request has been successfully requested.

**[0016]** FIG. 11 illustrates an exemplary screen displaying a notification that the phone number has been successfully transferred to the device.

**[0017]** FIG. 12 illustrates an exemplary screen displaying a notification that the number transfer process has been successfully completed.

**[0018]** FIG. 13 illustrates an exemplary screen displaying a notification that the device is checking whether the user requested a transfer of the user's existing mobile number to the new device.

**[0019]** FIG. 14 illustrates an exemplary screen displaying a notification that the phone number transfer request has been initiated.

**[0020]** FIG. 15 is a transactional diagram illustrating a device-initiated number porting process with automatic reprogramming in accordance with some embodiments.

## DETAILED DESCRIPTION

**[0021]** This document discloses a mobile device wireless service management system to provide automated phone number porting (also referred to herein as “phone number transferring” or “number transfer”).

**[0022]** A wireless device (also referred to herein as a “mobile device” or simply as a “device”) communicates over a wireless access network (also referred to as the “network”) with a network system comprising one or more network elements to access resources, such as data services, voice services, messaging services, transactional services, etc.

**[0023]** In a wireless network system, mobile devices authenticate with the network system based on credentials that are stored on the device and verified by the network system. Examples of credentials include, but are not limited to, a phone number, an international mobile subscriber identifier (IMSI), a mobile station identifier (MSID), a mobile station international ISDN number (MSISDN), a subscriber information module (SIM) identifier, an electronic serial number (ESN), a mobile equipment identifier (MEID), an international mobile equipment identity (IMEI), a device identifier, a subscriber identifier, a service account identifier, a media access control (MAC) address, an Internet protocol (IP) address, a token, a one-time token, a mobile directory number (MDN), a network access identifier (NAI), a user name, a password, access point name (APN) configuration information (e.g., APN name, APN username, APN password, APN gateway, APN SMSC/MMSC, APN type, etc.), an encryption key (Ki), a Wi-Fi service set identifier (SSID), a Wi-Fi network configuration (e.g., access point (AP) name, AP IP address, AP username, AP password, AP encryption type, AP security key, etc.), an IP address, any other identifying information that uniquely identifies a wireless device, and combinations of these. Some credentials (e.g., an ESN, a device identifier, etc.) are permanently associated with a device. But other credentials (e.g., a SIM, a phone number, etc.) may be moved from one device to another device. These movable credentials are referred to herein as “portable credentials.”

**[0024]** To gain access to a wireless access network, a subscriber needs some sort of account with the service provider (also referred to as an “operator,” “network operator,” “wireless operator,” or similar term). Although some consumers choose pre-loaded, pre-paid,

“disposable” devices, many consumers have ongoing accounts (either pre-pay or post-pay) with service providers. A subscriber’s account with a service provider is typically associated with a portable credential. For example, a subscriber account may be associated with a SIM card that stores information needed for a device containing the SIM to access a particular service provider’s network.

**[0025]** When a device is capable of making phone calls, the device and the subscriber’s account are associated with a telephone number (or “phone number”), which can be ported from one device to another or from one service provider to another. It is often the case that when a subscriber obtains a new device or moves his or her service subscription from one service provider to another, the subscriber wishes to remain associated with the same phone number he or she has been using.

**[0026]** There are several circumstances in which a phone number that is currently associated with a particular device and a current service provider needs to be ported. First, a subscriber could decide to upgrade or change the particular device to a new device, but stay with the current service provider and keep the current phone number. Second, a subscriber could decide to change from the current service provider to a new service provider, but keep the particular device and the current phone number. Third, a subscriber could decide to change from the current service provider to the new service provider, and also upgrade or change the particular device to the new device, but keep the current phone number. Fourth, a subscriber could have a first device associated with a first phone number and a first service provider, and a second device associated with a second phone number and a second service provider, and the subscriber wishes to port the first phone number to the second device.

**[0027]** When the subscriber decides to upgrade or change the particular device to a new device, but chooses to stay with the current service provider and keep the current phone number, the porting of the phone number is typically simple because the subscriber already has an account with the current service provider, and the subscriber’s phone number is already recognized by the current service provider. For GSM devices, porting the subscriber’s phone number from the current device to the new device is accomplished by moving the SIM from the

current device to the new device, which can often be done by the subscriber without support from or, in some cases, knowledge of the current service provider.

**[0028]** When the subscriber changes from the current service provider to a new service provider, however (e.g., the second, third, and fourth cases described above), the process of porting a number from one service provider to another takes some amount of time and can, in extreme cases, take days. At some point during the number porting process, the device and the network system of the current service provider can no longer communicate, and the device and the network system of the new service provider cannot communicate until the credentials stored on the device are updated to match the credentials stored in the new service provider's network system. Sometimes the new service provider sets up the subscriber's mobile device with temporary credentials so the mobile device can operate on the new wireless provider's network while the number porting process is ongoing. The temporary credentials allow the subscriber to begin using service with the new service provider immediately, even though the number porting is not complete. But because the credentials that allow the subscriber to use service with the new service provider while the number porting process is ongoing are temporary credentials, when the porting process is complete, the subscriber's mobile device needs to be updated with the desired credentials, including the subscriber's phone number.

**[0029]** Today, when it is necessary to update a wireless device using temporary credentials so that the device thereafter uses the intended credentials, the user of the wireless device may need to intervene to update the credentials so the device can communicate with the new service provider's network system with its desired credentials. This intervention is sometimes a sequence of steps that forces the device into a state where it can contact a programming server to get its credentials updated. Other times, the sequence entails the user manually programming the credentials into the device.

**[0030]** Disclosed herein are systems, devices, and methods that provide for the updating of device credentials after a phone number port without user intervention. In some embodiments, the mobile device detects a network provisioning state change (e.g., detects that the device credentials are to be updated) and automatically initiates a programming session with a programming server to enable the device to obtain the desired credentials without the

intervention of the user. Automation of this process ensures that the updating of credentials occurs when necessary and without user intervention. One of the benefits of this process is that it can reduce calls to a customer care center because this process helps to ensure that the device does not enter into a state in which it cannot interact with the network system and, as a result, appear to be unusable to the end user.

**[0031]** In some embodiments, the device comprises one or more device agents that determine when the desired phone number, previously associated with a different service provider, is available for porting onto the device so that a user of the device does not need to take any action to determine when the number is available for porting or to begin the porting process. In these and other embodiments, the one or more device agents may be configured to automatically determine that the desired phone number is available for porting and initiate the device side of the number porting process. In some embodiments, the one or more device agents are embodied in a service processor on the device.

**[0032]** In some embodiments, the device user can initiate number porting during initial account set up or creation, or during initial device setup, directly on the device. In some embodiments, the user can enter, through a user interface of the device, a request to cause a different device's phone number to be ported onto the device.

**[0033]** FIG. 1 illustrates components of a typical wireless network system. Mobile device 100 communicates with core network 110 through base station 125. To gain access to voice, messaging, and data services, mobile device 100 authenticates with various network elements, including home location register (HLR) 132, authentication server 1153, and network access gateway 1151. Failure to authenticate with these elements normally results in denied service access via the wireless network.

**[0034]** In some embodiments, a subscriber is able to initiate a number port (or "number transfer") directly from mobile device 100. In some embodiments, the subscriber accesses a device application and enters, into a device application user interface (UI), the information needed to initiate the port. In some embodiments, the number porting is assisted by one or more device agents that run on the mobile device that the phone number is desired to be ported to. The one or more device agents can comprise an application program, an operating system (OS)

component, an OS function, an OS service, a modem programming agent, a modem software or firmware agent, an over-the-air (OTA) mobile device parameter programming agent, an Open Mobile Alliance (OMA) agent, a secure communication agent configured to communicate number porting and number provisioning information, another software or firmware agent, or a combination of these.

**[0035]** In some embodiments, the one or more device agents communicate with one or more network elements (e.g., porting server 1154) that are configured to exchange number porting information and number provisioning information with the one or more device agents. In some embodiments, the one or more device agents establish a secure communication link with the one or more network elements to allow the secure exchange of number porting information and number provisioning information. In some embodiments, the formatting and/or protocols for the communications between the one or more device agents and the one or more network elements are established according to an application programming interface (API) between the one or more device agents responsible for (e.g., initiating) number porting and the one or more network elements that assist in the porting.

**[0036]** In some embodiments, after the one or more device agents collect the information from the subscriber, the one or more device agents communicate the information to porting server 1154. In some embodiments, the communication is over a cellular network. In some embodiments, the communication is over the short messaging service (SMS) channel. In some embodiments, the communication is over a Wi-Fi network. Porting server 1154 is responsible for initiating and managing the porting process between the wireless operator and the porting agency (or the subscriber's previous service provider, or an intermediary brokering system). In some embodiments, mobile device 100 stores a local copy of the subscriber's phone number that was entered on the device application when the port was initiated.

**[0037]** In some embodiments, a subscriber wishes to port a phone number associated with a second device or a second service account (the "second phone number") to a first device. In some such embodiments, the number porting is assisted by one or more network elements (e.g., porting server 1154) that are configured to communicate with the one or more device agents on the first device to exchange account information. The one or more network elements

then submit the request or instruction to port the second phone number to the first device to a subscriber management system responsible for managing the association of the second phone number with the second device or the second service account. The one or more network elements then obtain an indication that the second phone number has been released, and the one or more network elements communicate with the one or more device agents to cause the second phone number to be ported to the first device. In some embodiments, a subscriber management system responsible for managing the association of the second phone number with the first device participates in the number porting process by provisioning an aspect of the network policy associated with the first device to recognize or authenticate the second phone number for the first device.

**[0038]** In some embodiments, a first subscriber management system that manages a first device communicates with a second subscriber management system that manages a second device to request the phone number port and provides user information to authenticate the port of a phone number from either the first device to the second device or vice versa. In some embodiments the first device and/or number and second device and/or number are both managed by the same subscriber management system; in this case, the subscriber management system goes to itself to request the number port and provides user information to authenticate the port.

**[0039]** Once the porting process is complete, porting server 1154 updates wireless operator provisioning server 162, which then provisions certain network elements, including programming server 1152, with the new credentials (e.g., telephone number, network access identifier (NAI), user name, password, IP address, etc.), including the telephone number. In some embodiments, the updating of the provisioning information to the network elements will cause mobile device 100 to stop functioning on the network because its credentials are no longer associated with an active subscriber account.

**[0040]** In some embodiments, when the provisioning of the network system with the new device credentials is complete, mobile device 100 detects that it can no longer access the network. Detection of denied access to the network can include failed registration attempts, failed authentication attempts (e.g., invalid user name, invalid password, invalid telephone number, invalid device identifier, etc.), or failed authorization for services. When mobile device

100 detects that it can no longer access the network, it checks its internal state. In some embodiments, detecting the internal state comprises comparing one or more current device credentials with an expected credential (e.g., comparing a current phone number with an expected new phone number). When mobile device 100 detects that a current device credential does not match the expected credential, and mobile device 100 expects the credential to change, mobile device 100 enters into a programming session with programming server 1152. In some embodiments, putting mobile device 100 into a programming session entails providing a set of bootstrap credentials to mobile device 100, where the bootstrap credentials provide the mobile device with limited access to the network (e.g., mobile device 100 can only access the programming server 1152 either directly or indirectly via network access gateway 1151). In some embodiments, mobile device 100 is configured to communicate with programming server 1152 via a Wi-Fi or another type of alternative network. In some embodiments, the subscriber associated with mobile device 100 is not charged for usage of the wireless access network or alternative network associated with the device's communications with programming server 1152 (i.e., usage is not accounted to a user account, or usage is zero-rated by the service provider or another party).

**[0041]** Once mobile device 100 has access to programming server 1152, mobile device 100 initiates a programming communication session with programming server 1152. In some embodiments, device interaction with programming server 1152 is over the data channel, the SMS channel, the voice channel, the unstructured supplementary service data (USSD) channel, or over Wi-Fi or another network that provides mobile device 100 with access to programming server 1152. In some embodiments, when mobile device 100 is accessing programming server 1152, access to other network elements or network end-points is restricted or prohibited. Programming server 1152 delivers the new device credentials to the mobile device 100. Mobile device 100 receives the updated credentials and stores the new credentials locally on the device. Upon completion of the programming session, mobile device 100 begins to use the new credentials to access the wireless network. In some embodiments, mobile device 100 compares the new credentials to the expected credentials to determine if the current credentials are, in fact, the expected credentials or additional interim credentials. In some embodiments, if the current credentials match the expected credentials, the update process is determined to be complete.

**[0042]** In some embodiments, an over the air device provisioning network element (e.g., programming server 1152) participates in the number porting process by causing an aspect of a first device's credentials to be re-programmed to provision a new phone number onto the first device. In some embodiments, the aspect of the first device's credentials that is re-programmed to provision the new phone number onto the first device comprises the phone number or mobile directory number (MDN), NAI, password, access point name (APN) configuration information (e.g., APN name, APN username, APN password, APN gateway, APN SMSC/MMSC, APN type, etc.), username, IP address, MAC address, international mobile subscriber identity (IMSI), encryption key (Ki), Wi-Fi service set identifier (SSID), Wi-Fi network configuration (e.g., access point (AP) name, AP IP address, AP username, AP password, AP encryption type, AP security key, etc.), or a combination of these.

**[0043]** It is to be appreciated that the functions described above are illustrated in FIG. 1 in a particular way, but that the functions may be disposed differently than shown in FIG. 1. In particular, the functions may be performed by more or fewer network elements than shown in FIG. 1.

**[0044]** FIG. 2 illustrates various components of mobile device 100, including UI display 1000, through which the subscriber can interact with the device application via the display and UI element (e.g., on-screen keyboard, speech recognition processor, physical keyboard, etc.). Current credential storage 1157 is device memory where mobile device 100 stores its current credentials to access the wireless network. In some embodiments, current credential storage 1157 is protected or encrypted to prohibit the user from directly (or indirectly) modifying the information stored in current credential storage 1157. In some embodiments, current credential storage 1157 is accessible only to the wireless modem that allows the device to access the wireless access network.

**[0045]** Programming session credential storage 1156 is device memory where mobile device 100 stores the credentials and configuration to access programming server 1152. In some embodiments, the programming session credentials include network type (e.g., cellular, Wi-Fi, Bluetooth, etc.), network name (e.g., APN name, Wi-Fi SSID, etc.) or other information that enables mobile device 100 to access programming server 1152. In some embodiments,

programming session credential storage 1156 is protected or encrypted to prohibit the user from directly (or indirectly) modifying the information stored in programming session credential storage 1156. In some embodiments, programming session credential storage 1156 is accessible only to the wireless modem that allows the device to access the wireless access network.

**[0046]** Expected credential storage 1158 is device memory where mobile device 100 stores the expected credentials to be programmed to mobile device 100. In some embodiments, mobile device 100 uses the expected credentials to detect when mobile device 100 has received its final set of credentials related to the transaction that caused the credentials to change (e.g., a request to port a new phone number to mobile device 100). For example, the expected credentials could be the porting phone number, a new network access identifier, a new IP address, etc.

**[0047]** It is to be appreciated that although FIG. 2 illustrates current credential storage 1157, expected credential storage 1158, and programming session credential storage 1156 separately, they may all be located in the same memory (which may be secure memory).

**[0048]** FIG. 3 is a flowchart showing a procedure to update one or more credentials of a mobile device in accordance with some embodiments. At 1160, the procedure starts. At 1161, the device user requests to have at least some aspect of the one or more device credentials changed via a UI interaction on the device. Examples of UI interaction include interaction with a browser application, an OS application, an OS settings application, a native application, etc. The UI interaction causes the device to communicate with an application server (e.g., porting server 1154, programming server 1152) to facilitate and complete the credential change request.

**[0049]** At 1162, the device stores (e.g., using one or more device agents) the requested credential information locally on the device. In some embodiments, the device receives this information from the application server or other network element. In some embodiments, the device receives this information from the UI interaction application on the device or from the one or more device agents. In some embodiments, the requested credential information includes information about all of the one or more credentials that were requested to be changed. In some embodiments, the requested credential information contains a subset of information about all of the one or more credentials that were requested to be changed. In some embodiments in which,

at the time the number port is requested, the device is associated with a first phone number and/or other first credential(s), the number being ported and/or other re-provisioning information is not fully programmed onto the device before the first number and/or other first credential(s) become partially invalid or invalid.

**[0050]** At 1163, the device detects the network provisioning state change. There are a number of ways in which the device can detect the network provisioning state change, including denied registration attempts, denied voice call attempts, denied text message transmission attempts, failed authentication with a network element, failed authorization for services, or any other mechanism that signals the device that network provisioning has changed.

**[0051]** At 1164, the device determines whether a current credential matches the requested credential to determine if there is a mismatch between the credential that is currently programmed on the device and the credential that the device is expecting to be programmed on the device. In some embodiments, the requested credential may be a configuration state indicator, and the device inspects the configuration state indicator to determine if the device expected additional credential updates associated with the credential change request.

**[0052]** At 1165, the device has determined that it is expecting a credential update, and as a result the device initiates a programming session (e.g., the one or more device agents initiate a programming session). In some embodiments, initiating a programming session entails setting the device to a well-known configuration state (e.g., a bootstrap state, etc.) to enable the device to contact a network element (e.g., programming server 1152). In some embodiments, initiating a programming session entails switching the device to an alternative network (e.g., Wi-Fi, etc.) or communication channel (e.g., SMS, etc.) prior to initiating communications with the network element (e.g., programming server 1152). In some embodiments, the communication with the network element (e.g., programming server 1152) utilizes an ambient service so that usage of the wireless access network associated with the device's communication with the network element is subsidized or paid-for by an entity other than the party responsible for paying for access to the wireless access network by the device (e.g., the party responsible for paying for access to the wireless access network by the device is the user, subscriber, account-holder, enterprise, parent, etc.). In some embodiments, when the communication with the network element (e.g.,

programming server 1152) occurs using an ambient service, the party responsible for paying for access to the wireless access network by the device (e.g., the user, subscriber, account-holder, enterprise, parent, etc.) is not charged for the network communications associated with the device programming.

**[0053]** At 1166, the device communicates with the network element (e.g., programming server 1152) to obtain its updated credential(s). In some embodiments, the device performs an authentication process with the network element (e.g., programming server 1152). In some embodiments, the configuration data is encrypted or delivered over an encrypted and secure channel. In some embodiments, the configuration data is encrypted using device-specific information (e.g., an IMSI, Ki, A-key, MAC address, etc.), either directly or indirectly.

**[0054]** At 1167, after the device receives its updated credentials, it updates its local memory with the new credentials. In some embodiments, the updated credentials also include updated device configuration information (e.g., access server information, new data network configuration, device UI configuration, branding information, etc.). For example, the updated device configuration information can include a logo, color scheme, icon, or any other branding information that indicates the device is now associated with a different service provider.

**[0055]** At 1168, the device compares the updated credentials with the expected credentials to determine if the credential update process associated with the initial transaction (at 1161) is complete. In some embodiments, there may be additional interim credentials assigned to the device while the transaction is in progress. In some embodiments, the transaction requires multiple credential updates. In some embodiments, the device checks a credential update state variable to determine if the credential update process is complete. If the credential update process is complete, the process ends at 1169. If the device expects further credential updates associated with the transaction initiated at 1161, the device continues to monitor for network provisioning state change (at 1163) and continues the cycle until the credential update process completes.

**[0056]** In some embodiments, the device performs the updating process automatically without informing the subscriber. In some embodiments, the credential update occurs in the background and is undetected by the user. In some embodiments, the programming process

requires the device to be restarted one or more times. In some embodiments, when a reboot is required, it is desirable to present a visual or audible notification to the user to inform the user that the device is updating and/or rebooting. In some embodiments, the notification enables the user to postpone the update and/or device reboot.

**[0057]** In some embodiments, the one or more device agents present a number porting option through a first device's UI to enable a user to port a phone number that is currently assigned to a second device (the "second phone number") onto the first device. In some embodiments, such as the exemplary embodiment shown in FIG. 4, the one or more device agents present an account UI screen 1170 to the user and provide a mechanism to request a new phone number or initiate a phone number transfer (e.g., port of the second phone number to the first device) request from the device. The UI element could be a menu item, a status bar item, a list item, dialog box, or any other UI construct to enable the user to initiate a phone number transfer request. In the embodiment illustrated by FIG. 4, the UI construct is a touch-sensitive button the user can touch to initiate a number transfer. As illustrated by FIG. 4, the screen 1170 informs the user that the user can press the "Transfer" button either to transfer an existing number to the device, or to request a new number.

**[0058]** In some embodiments, such as the exemplary embodiment shown in FIG. 5, in response to the user initiating a transfer (e.g., selecting "Transfer" in the embodiment shown in FIG. 4), the one or more device agents present a number management screen 1171 to the user and provide a mechanism to either request a new number or initiate a number transfer (port) request from the device. The UI element could be a menu item, a status bar item, a list item, dialog box, or any other UI construct to enable the user to manage his or her phone number on the device. In some embodiments, the one or more device agents may restrict the parties who are authorized to transfer a number. In the embodiment shown in FIG. 5, for example, a number transfer can be initiated from any device with the "Admin" role, where the "Admin" role is held by a subscriber, a parent, an enterprise, a device group manager, or any other designated party who is authorized to modify the settings or characteristics of the device for which the number transfer is being requested.

**[0059]** In some embodiments, when the user initiates the transfer of the second phone number from a first service provider to a second service provider (e.g., the user selects “Transfer my number from another phone” on the screen 1171 shown in FIG. 5), the one or more device agents present a screen to inform the user about information the user will need to provide in order to complete the request. In the embodiment shown in FIG. 6, for example, the one or more agents assist in presenting a notification 1172 through the display to inform the user that he or she should have a copy of the user’s last bill from the first service provider (so that the user can enter, for example, an account number or other information commonly found on a service provider bill), the phone number to transfer, the first and last name of the user, the user’s address, and the user’s social security number or account number (or account name) with the first service provider.

**[0060]** In some embodiments, when the user accepts the number porting option (e.g., the user selects the “Continue” option of FIG. 5 or the “OK” option of FIG. 6), the one or more device agents present a screen to gather the second phone number, user information, and/or account information associated with the service account currently associated with the second phone number. In some embodiments, such as the representative screens 1173 and 1174 illustrated in FIGS. 7A and 7B, once the user decides to initiate a phone number transfer request, the user enters the requested information through the device UI to allow the second phone number to be transferred to the device (e.g., from a first service provider currently providing service to the second phone number to the service provider associated with the device to which the second phone number is requested to be transferred). In some embodiments, the information entered by a user to transfer a phone number includes one or more of the following pieces of information: phone number to transfer, billing first name, billing last name, company name, billing address (e.g., street number, street name, city, state, ZIP code), user’s social security number, a portion of the user’s social security number (e.g., last 4 digits), current-service-provider account number, current-service-provider account password, current-service-provider account PIN, or any other information to identify the subscriber or the account with the current service provider. In some embodiments, to prevent the inadvertent or malicious transfer of the second phone number to the device, the information entered includes information that is or should only be known by a subscriber associated with the second phone number (e.g., some or all of the subscriber’s social security number, account number, password, PIN, etc.)

**[0061]** In some embodiments, all of the information to be collected to initiate the transfer of the second phone number to the device is entered on a single UI screen. In some embodiments, such as the exemplary embodiment of FIGS. 7A and 7B, the information to be collected is entered on multiple UI screens 1173 and 1174. In some embodiments, the user is queried about the current service provider (e.g., identifying information about the service provider currently providing service associated with the second phone number). In some embodiments, a network element assists in determining the current service provider by querying an entity. In some embodiments, the entity is a local database, a porting management entity, a remote database, or another system that contains the information. In some embodiments in which the current service provider is known, the information to be collected by the one or more device agents on the mobile device is tailored to the requirements of the current service provider (e.g., service provider “A” only requires first name, last name, phone number to port, and billing zip code; service provider “B” only requires phone number to port and account password, etc.).

**[0062]** In some embodiments, after the user enters the information needed for the one or more device agents to initiate the number transfer, the one or more device agents assist in presenting a confirmation screen through the user interface of the device. FIG. 8 illustrates an example of such a confirmation screen 1175. As shown in FIG. 8, the confirmation screen 1175 informs the user that it is important that the information provided by the user to initiate the transfer of the second phone number be correct. The screen of FIG. 8 asks the user to review the information and confirm that the information entered is correct.

**[0063]** In some embodiments, after the user has provided the information needed for the one or more device agents to initiate the number transfer (e.g., the user has provided the information requested by the screens 1173 and 1174 illustrated in FIGS. 7A and 7B, or the user has selected “OK” from the screen 1175 illustrated in FIG. 8), the one or more device agents initiate the number transfer and provide a notification to the user that the number transfer process is beginning. FIG. 9 illustrates a specific embodiment of such a notification 1176. As shown in FIG. 9, the notification 1176 may include an icon or other indicia to indicate to the user that the number transfer information is being submitted.

**[0064]** In some embodiments, after the one or more device agents have successfully initiated the number transfer, the one or more device agents assist in providing a notification to the user to inform the user that the number transfer has been requested. In some embodiments, the notification provides additional information, such as when the number transfer is expected to be completed. FIG. 10 illustrates a particular embodiment of such a notification 1177. The notification 1177 informs the user that the number transfer has been successfully requested, and that transferring the number may take up to four hours to complete.

**[0065]** In some embodiments, as the porting process proceeds, the one or more device agents present notification messages (e.g., audible or visible notifications) through a first device UI to inform the user of the progress of the porting process. For example, the one or more device agents can present one or more messages through a display to inform the user that the port is proceeding, that the device has limited or no access to the wireless access network, that settings are being updated, that information is being loaded, that the device needs to be rebooted, etc. For example, the messages may inform the user that the user needs to reboot the device in order for the number port to complete. FIG. 11 illustrates a particular embodiment of such a notification 1178. In the embodiment of FIG. 11, the notification 1178 informs the user that the phone number has been successfully transferred to the device. In the embodiment of FIG. 11, the notification 1178 also informs the user that the device will need to update itself with its new number, and that during the update process, the user will not be able to use the device or make emergency calls. In addition, in the embodiment of FIG. 11, the notification 1178 informs the user that during the update process, the device will restart twice without user intervention, and the user may see additional messages as the device updates and activates. In the embodiment of FIG. 11, the notification 1178 presents the user with an option to defer the updating process until later.

**[0066]** The one or more device agents can also present a notification upon completion of the number porting process to inform the user that the port was successful and/or that the device is now associated with the second phone number. FIG. 12 illustrates one such embodiment. In the embodiment of FIG. 12, the notification 1179 informs the user that the device is now active with its new number (the second phone number).

**[0067]** The one or more device agents can also present a notification if the number porting process fails, where such notification informs the user of the failure and, in some embodiments, provides additional information about the failure and/or directs the user to customer service for assistance.

**[0068]** In some embodiments, a user orders a new device through a website associated with the new service provider. In some such embodiments, the user specifies when ordering the new device that the user wishes to port an existing phone number to the new device. Because the user does not want the number to be ported before the user has received the device, the new service provider pre-configures the new device with information that will allow the transfer of the existing number to the new device after the user receives the new device. When the user receives the new device and powers on the device, the device initiates the number transfer using information pre-configured by the new service provider. FIG. 13 illustrates a notification message 1180 that a user of the new device sees in accordance with a particular embodiment. As shown in FIG. 13, the one or more device agents assist in presenting a notification message 1180 that informs the user that the one or more device agents are checking to see whether the user requested a transfer of the user's existing mobile number to the new device. FIG. 14 illustrates a notification message 1181 that a user of the new device might see if the one or more device agents determine that the user requested a number transfer prior to receiving the new device. In the embodiment illustrated in FIG. 14, the notification message 1181 informs the user that the number transfer request is being initiated. In some embodiments in which the user requests a number transfer at the time of ordering a device, the one or more device agents perform one or more of the tasks described previously in the context of FIGS. 9-12.

**[0069]** FIG. 15 illustrates a device-initiated number porting process with automatic reprogramming according to some embodiments. In FIG. 15, the subscriber 1010 desires to port his number from his or her prior service provider to a new service provider. The subscriber 1010 initiates a port request with assistance from one or more device agents (shown simply as "Device Agent" in FIG. 15). The one or more device agents assist in collecting the number porting information from the subscriber 1010. The one or more device agents can comprise one or more of an application program, an operating system (OS) component, an OS function, an OS service, a modem programming agent, a modem software or firmware agent, an over-the-air (OTA)

mobile device parameter programming agent, an Open Mobile Alliance (OMA) agent, a secure communication agent configured to communicate number porting and number provisioning information, or another software or firmware agent.

**[0070]** Once the one or more device agents collect the porting information from the subscriber, the one or more agents communicate with porting server 1154A to communicate the porting request. Porting server 1154A is associated with the new service provider. Porting server 1154A can comprise one or more of a subscriber management system, a dedicated element to manage number porting, a clearinghouse porting server, a billing system, a provisioning system, or any other system that manages the number porting process for a service provider. Porting server 1154A communicates with porting server 1154B, which is associated with the subscriber's prior service provider, to request that the subscriber's telephone number be ported from the prior service provider to the new service provider. In some embodiments, porting server 1154A communicates directly with porting server 1154B. In some embodiments, porting server 1154A communicates with porting server 1154B via one or more intermediary servers or systems. In some embodiments, the one or more intermediary servers or systems are associated with a clearinghouse service to broker number porting requests between service providers.

**[0071]** Upon successful validation of the information associated with the subscriber's number porting request, porting server 1154B releases the association of the ported telephone number with the prior service provider and acknowledges the port phone number request to porting server 1154A. Once porting server 1154A receives the acknowledgement from porting server 1154B, porting server 1154A initiates a provisioning request to the current service provider's business/operational support systems (B/OSS) 1101. In some embodiments, provisioning of B/OSS 1101 includes provisioning programming server 1152 with the new device credentials and parameters. The new device credentials and parameters can comprise a phone number or mobile directory number (MDN), NAI, password, access point name (APN) configuration information (e.g., APN name, APN username, APN password, APN gateway, APN SMSC/MMSC, APN type, etc.), username, IP address, MAC address, International Mobile Subscriber Identity (IMSI), Encryption Key (Ki), Wi-Fi SSID, Wi-Fi network configuration (e.g., AP name, AP IP address, AP username, AP password, AP encryption type, AP security

key, etc.), or a combination of these. In some embodiments, provisioning of B/OSS 1101 includes provisioning of the network elements (e.g., HLR, HSS, 2A Server, gateway servers, authentication servers and systems, access control systems) to associate the new device credentials with subscriber 1010.

**[0072]** When device 100, using its existing credentials, attempts to authenticate or be authorized by the new service provider's network system 1100 for services, network system 1100 (shown in FIG. 15 as "Network") denies the request. When the one or more device agents receive the authentication or authorization failure, the one or more device agents automatically initiate a programming session with programming server 1152. In some embodiments, the one or more device agents assist in presenting (e.g., displaying a message through a device display or screen, providing an audible message through a speaker, etc.) a notification to subscriber 1010 prior to initiating the device reprogramming process. In some embodiments, the one or more device agents assist in causing device 100 to be rebooted prior to initiating the programming session, or they assist in notifying a user to reboot device 100. In some embodiments, the one or more device agents assist in configuring device 100 with credentials to enable the programming session. During the programming session, the one or more device agents receive the updated device credentials or parameters, and the one or more agents update the device credentials or parameters with the credentials or parameters received from programming server 1152.

**[0073]** Upon completion of the programming session, device 100 can successfully authenticate with the new service provider's network system 1100 and be authorized for services. In some embodiments, upon completion of the programming session, the one or more device agents assist in rebooting device 100 to enable it to use the new credentials. In some embodiments, upon completion of the programming session, the one or more device agents assist in resetting the modem to enable device 100 to use the new credentials. In some embodiments, the one or more device agents assist in presenting (e.g., displaying a message through a device display or screen, providing an audible message through a speaker, etc.) a notification to subscriber 1010 to provide information related to the completion of the phone number port.

**[0074]** Exemplary Use Case 1: Number porting information is pre-stored on the device before the number porting takes place

**[0075]** In some embodiments, a user wishes to port a phone number associated with a second device (the “second phone number”) to a first device. In some such embodiments, one or more device agents on the first device accept the second phone number and possibly other associated information about an account associated with the second device. The one or more device agents relay this information to a network element. In some embodiments, the one or more device agents are then prepared for auto-reprogram to the second phone number by pre-storing on the first device at least a portion of the provisioning information needed to port the second phone number before the number port has taken place in the network-based subscriber management systems and/or over-the-air (OTA) programming systems. In some embodiments, the one or more device agents are configured to detect a port initiation condition that indicates the porting process should be initiated, and the one or more device agents utilize the pre-stored information to assist in implementing the number port. In some embodiments, the port initiation condition comprises a condition where a first phone number, assigned to the first device at the time the porting request is initiated, is no longer assigned to the first device. In some embodiments, determining that the first phone number is no longer assigned comprises determining that the device cannot access a mobile network with the credentials associated with the first phone number. In some embodiments, the port initiation condition comprises a signal from the one or more network elements. In some embodiments, the port initiation condition comprises determining that network access over a mobile network has been restricted or prevented.

**[0076]** In some embodiments, the one or more device agents accept the second phone number desired to be ported onto the device, communicate the information to a network element, and prepare for auto-reprogram to the second phone number but do not re-program the device immediately. In some such embodiments, the one or more device agents wait for a condition in which the first phone number is no longer valid and then automatically re-program the device and re-acquire the network.

**[0077]** Exemplary Use Case 2: Device utilizes a restricted link once the number porting has been initiated

**[0078]** In some embodiments, a user wishes to port a phone number associated with a second device (the “second phone number”) to a first device. In some such embodiments, one or more device agents on the first device assist in the porting of the second phone number. In some embodiments, when the porting of the second phone number port is approved and the second phone number is released from the second service provider, the one or more device agents have access via a restricted mobile network access policy to a network server associated with the one or more device agents, and this network server assists in porting the second phone number to the first device. In some embodiments, the network server provides OTA programming of the second phone number and possibly other parameters (e.g., other credentials). In some embodiments, after providing OTA programming, the network server causes the device to authenticate or re-authenticate to the network system.

**[0079]** In some embodiments, a limited-access-permission ambient (i.e., non-user-paid) service through the wireless access network is provided to enable devices that do not have a valid phone number or other network access credential to communicate with a programming server. In some such embodiments, some or all devices that are not recognized by the network authentication system have access to a server that can re-provision a device’s phone number, other network access credentials, or other network access configuration if a number port has been authorized and/or completed for the device.

**[0080]** In some embodiments, at some point in number porting process a subscriber management system associated with the first device provisions the network elements to reflect the second phone number and/or device access credentials, and at that point a policy allows the first device to have limited network access to communicate with the programming server, even if the first device has a partially invalid credential or set of credentials.

**[0081]** Exemplary Use Case 3: The mobile network recognizes two numbers for the first device, at least for a period of time

**[0082]** In some embodiments, a user wishes to port a phone number associated with a second device (the “second phone number”) to a first device that, at the time the porting request is initiated, is associated with a first phone number. In some such embodiments, one or more device agents on the first device assist in the porting of the second phone number. In some

embodiments, the network system is configured to allow the first device to access the network system with credentials associated with the first phone number and with credentials associated with the second phone number, at least for a period of time. In some such embodiments, when the number port is complete, and the first device accesses the network with credentials associated with the first phone number, the programming server or other network element signals to the first device (e.g., sends an SMS message to the one or more device agents, sends a data transport message to the one or more device agents, etc.) that the device requires reprogramming. In some embodiments, the one or more device agents initiate communications with the programming server to retrieve the new network access credentials (e.g., the credentials associated with the second phone number). In some embodiments, the new credentials are pre-stored on the first device, and the first device automatically reprograms itself without contacting the programming server.

**[0083]** In some embodiments, it is also desirable to update another configuration of the first device, including, for example, an application configuration. In some embodiments, there are certain applications that use device-related credentials to access a service where the service associates a device or user with a set of well-known credentials (e.g., a voice mail application). In some embodiments, when the phone number or other credential associated with the first device changes, the applications that use device credentials must communicate the device or subscriber credential change to the service. In some embodiments, a network element (e.g., provisioning server, programming server, subscriber management server, etc.) assists in updating the service with the new device credential. In some embodiments, the device application is required to log in, authenticate, or associate the user's service with the new credential. In some embodiments, the re-authentication, log in, or service association occurs automatically without user intervention. In some embodiments, prior to the re-authentication, log in, or service association with the new credential, the user is required to enter a valid PIN, password, or other credential to authorize the change to the service credentials. In some embodiments, the service credentials include access credentials. In some embodiments, the service credentials include account credentials or information (e.g., phone number for voice mail account, etc.)

**[0084]** In some embodiments, an already-resident or downloaded application exists on the user's current device. In some embodiments, the application assesses usage and determines

if there is a better service offer (i.e., a service offer that would reduce costs to the user or that would otherwise benefit the user). In some embodiments, the better service offer is a service offer with the user's current service provider (i.e., the service provider associated with the user's current device). In some embodiments, the better service offer is with a different service provider. In some embodiments, the application provides information about the better service offer to the user through the device UI (e.g., by presenting information through a display, by providing an audible notification, etc.). In some embodiments, the application accepts a user indication that user wishes to accept the better service offer, and accepts billing information. In some embodiments, the application communicates that the user wishes to accept the service offer and billing information to a network element. In some embodiments, the network element is on the current service provider's network. In some embodiments, the network element is on the new service provider's network (i.e., the network operated by the service provider making the service offer that the user wishes to accept). In some embodiments, the network element is on a third-party network that is not owned by either the current service provider or the new service provider (e.g., the network element is on an independent agent/broker network). In some embodiments, the network element initiates the shipment of a new device (e.g., a new device providing the better service offer is sent or made available to the user). In some embodiments, when the user receives the new device, the user can either initiate number porting from an application that runs during initial device set up or via the one or more device agents on the new device.

**[0085]** In some embodiments, the user can enter the information to port a phone number through a website (either prior to activating service or once service is activated). In some embodiments, where the information is entered using a website, the one or more device agents are automatically triggered by a message communicated over the wireless network by a network element to initiate the number port (e.g., SMS message, USSD message, application push message (Google Cloud Messaging (GCM), Apple Push Notification Service (APNS), etc.)). In some embodiments, the one or more device agents assist in prompting the user to confirm the port request. In some embodiments, the port is initiated automatically in the background with no user intervention. In some embodiments, where the user enters the porting information through a website, the one or more device agents present the porting information through the device UI and

at least assist in querying the user to verify and/or edit the porting information on the mobile device prior to initiating the port.

WHAT IS CLAIMED IS:

## CLAIMS

1. A wireless device, comprising:

a user interface;

memory configured to store:

5 one or more credentials associated with the wireless device, the one or  
more credentials for enabling the wireless device to obtain one or more  
services over a wireless access network, and  
a target credential; and

one or more processors configured to execute one or more machine-executable  
10 instructions that, when executed by the one or more processors, cause the one  
or more processors to:

obtain, through the user interface, an indication of a user request to replace  
a particular credential of the one or more credentials with the target  
credential,

15 detect a network-provisioning state change,

based on the detected network-provisioning state change, determine that  
the particular credential does not match the target credential,

initiate a programming session with a network element communicatively  
coupled to the wireless device over the wireless access network,

20 obtain an updated credential from the network element, and

assist in storing, in memory, the updated credential as the particular  
credential.

2. The wireless device recited in claim 1, wherein, when executed by the one or more  
25 processors, the one or more machine-executable instructions further cause the one or  
more processors to:

determine that the updated credential does not match the target credential, and  
based on the determination that the updated credential does not match the target  
credential, take an action.

30

3. The wireless device recited in claim 2, wherein the action is to communicate with the network element.
4. The wireless device recited in claim 2, wherein the action is to cause a notification to be presented through the user interface, wherein the notification reports an error.
5. The wireless device recited in claim 2, wherein the action is to cause a notification to be presented through the user interface, wherein the notification reports that a procedure is in progress or has not been completed.
6. The wireless device recited in claim 2, wherein the action is to at least assist in restricting communications by the wireless device over the wireless access network.
7. The wireless device recited in claim 1, wherein, when executed by the one or more processors, the one or more machine-executable instructions further cause the one or more processors to:
- determine that the updated credential matches the target credential, and
  - based on the determination that the updated credential matches the target credential, take an action.
8. The wireless device recited in claim 7, wherein the action is to cause a notification to be presented through the user interface, wherein the notification reports that the particular credential has been replaced by the target credential.
9. The wireless device recited in claim 1, wherein, when executed by the one or more processors, the one or more machine-executable instructions further cause the one or more processors to cause a notification to be presented through the user interface, the notification providing information about a status of the user request to replace the particular credential of the one or more credentials with the target credential.

10. The wireless device recited in claim 1, wherein, when executed by the one or more processors, the one or more machine-executable instructions further cause the one or more processors to cause a notification to be presented through the user interface, the notification requesting confirmation of the user request to replace the particular credential with the target credential.
- 5
11. The wireless device recited in claim 1, wherein detecting the network-provisioning state change comprises determining that a registration attempt initiated by the wireless device has failed.
- 10
12. The wireless device recited in claim 1, wherein detecting the network-provisioning state change comprises determining that an attempt by the wireless device to place a voice call has failed.
- 15
13. The wireless device recited in claim 1, wherein detecting the network-provisioning state change comprises determining that an attempt by the wireless device to send a text message has failed.
- 20
14. The wireless device recited in claim 1, wherein detecting the network-provisioning state change comprises determining that an attempt by the wireless device to authenticate with the network element has failed.
- 25
15. The wireless device recited in claim 1, wherein detecting the network-provisioning state change comprises determining that an attempt by the wireless device to be authorized for a service has failed.
16. The wireless device recited in claim 1, wherein detecting the network-provisioning state change comprises determining that a network access error has occurred.
- 30
17. The wireless device recited in claim 1, wherein detecting the network-provisioning state change comprises receiving a provisioning-state-change message.

18. The wireless device recited in claim 17, wherein the provisioning-state-change message comprises a text message.
- 5 19. The wireless device recited in claim 17, wherein the provisioning-state-change message comprises a push message from a push server communicatively coupled to the wireless device over the wireless access network.
20. The wireless device recited in claim 17, wherein the provisioning-state-change message  
10 comprises a message received by an application program on the wireless device.
21. The wireless device recited in claim 1, wherein the one or more credentials comprise a phone number.
- 15 22. The wireless device recited in claim 1, wherein the one or more credentials comprise an international mobile subscriber identifier (IMSI), a mobile station identifier (MSID), a mobile station international ISDN number (MSISDN), a subscriber information module (SIM) identifier, an electronic serial number (ESN), a mobile equipment identifier (MEID), an international mobile equipment identity (IMEI), a device identifier, a  
20 subscriber identifier, a service account identifier, a media access control (MAC) address, an Internet protocol (IP) address, a token, a one-time token, a mobile directory number (MDN), a network access identifier (NAI), a user name, a password, access point name (APN) configuration information, an encryption key (Ki), a Wi-Fi service set identifier (SSID), a Wi-Fi network configuration, an IP address, or a combination of these.
- 25 23. The wireless device recited in claim 1, wherein the target credential comprises a phone number.
24. The wireless device recited in claim 1, wherein the target credential comprises an  
30 international mobile subscriber identifier (IMSI), a mobile station identifier (MSID), a mobile station international ISDN number (MSISDN), a subscriber information module

(SIM) identifier, an electronic serial number (ESN), a mobile equipment identifier (MEID), an international mobile equipment identity (IMEI), a device identifier, a subscriber identifier, a service account identifier, a media access control (MAC) address, an Internet protocol (IP) address, a token, a one-time token, a mobile directory number (MDN), a network access identifier (NAI), a user name, a password, access point name (APN) configuration information, an encryption key (Ki), a Wi-Fi service set identifier (SSID), a Wi-Fi network configuration, an IP address, or a combination of these.

25. The wireless device recited in claim 1, wherein the particular credential comprises a first phone number currently associated with the wireless device, and wherein the target credential comprises a second phone number.

26. The wireless device recited in claim 25, wherein the wireless device is a first wireless device, and wherein the second phone number is associated with a second wireless device.

27. The wireless device recited in claim 25, wherein the second phone number is associated with a land line.

28. The wireless device recited in claim 1, wherein the user interface comprises a display.

29. The wireless device recited in claim 1, wherein the user interface comprises a speaker.

30. The wireless device recited in claim 1, wherein the one or more services comprise a voice service, a messaging service, or a data service.

31. The wireless device recited in claim 1, wherein the one or more machine-executable instructions comprise an application program.

32. The wireless device recited in claim 1, wherein the one or more machine-executable instructions comprise an operating system (OS) component, an OS function, an OS

service, a modem programming agent, a modem software or firmware agent, an over-the-air (OTA) mobile device parameter programming agent, an Open Mobile Alliance (OMA) agent, a secure communication agent configured to communicate number porting and number provisioning information, a software agent, a firmware agent, or a combination of these.

5  
33. The wireless device recited in claim 1, wherein the user request comprises an indication of the target credential, a phone number, a user name, a password, an account number, a subscriber name, a company name, at least a portion of a billing address, at least a portion of a social security number, a personal identification number (PIN), or a combination of these.

10  
34. The wireless device recited in claim 1, wherein obtaining the indication of the user request to replace the particular credential of the one or more credentials with the target credential comprises obtaining information from a website.

15  
35. The wireless device recited in claim 1, wherein obtaining the indication of the user request to replace the particular credential of the one or more credentials with the target credential comprises obtaining information associated with the user request through the user interface.

20  
36. The wireless device recited in claim 1, wherein the network element comprises a programming server.

25  
37. The wireless device recited in claim 1, wherein initiating the programming session with the network element communicatively coupled to the wireless device over the wireless access network comprises contacting the network element using at least a portion of the one or more credentials associated with the wireless device.

38. The wireless device recited in claim 1, wherein initiating the programming session with the network element communicatively coupled to the wireless device over the wireless access network comprises contacting the network element using a temporary credential.
- 5 39. The wireless device recited in claim 38, wherein, when executed by the one or more processors, the one or more machine-executable instructions further cause the one or more processors to obtain the temporary credential from memory.
40. The wireless device recited in claim 38, wherein, when executed by the one or more  
10 processors, the one or more machine-executable instructions further cause the one or more processors to obtain the temporary credential from a network system communicatively coupled to the wireless device.
41. The wireless device recited in claim 1, wherein initiating the programming session with  
15 the network element communicatively coupled to the wireless device over the wireless access network comprises contacting the network element using a default credential.
42. The wireless device recited in claim 1, wherein initiating the programming session with  
20 the network element communicatively coupled to the wireless device over the wireless access network comprises communicating with the network element over the wireless access network.
43. The wireless device recited in claim 1, wherein initiating the programming session with  
25 the network element communicatively coupled to the wireless device over the wireless access network comprises communicating with the network element over a Wi-Fi network.
44. The wireless device recited in claim 1, wherein initiating the programming session with  
30 the network element communicatively coupled to the wireless device over the wireless access network comprises communicating with the network element through a voice call.

45. The wireless device recited in claim 1, wherein, when executed by the one or more processors, the one or more machine-executable instructions further cause the one or more processors to at least assist in restricting communications over the wireless access network until the updated credential has been obtained.

5

46. The wireless device recited in claim 1, wherein the target credential comprises a configuration state indicator.

47. A non-transitory computer-readable storage medium storing one or more machine-executable instructions that, when executed by one or more processors of a wireless device, cause the one or more processors to:

obtain, through a user interface, an indication of a user request to replace a particular credential of one or more credentials with a target credential;  
detect a network-provisioning state change;  
based on the detected network-provisioning state change, determine that the particular credential does not match the target credential;  
initiate a programming session with a network element communicatively coupled to the wireless device over a wireless access network;  
obtain an updated credential from the network element; and  
assist in storing, in memory, the updated credential as the particular credential.

15  
20

48. A method performed by a network system communicatively coupled to a wireless device by a wireless access network, the method comprising:

receiving, from the wireless device, a request to replace a first credential of the wireless device with a target credential;  
based on the first credential and the target credential, initiating a network-provisioning state change;  
sending a message to the wireless device, the message indicating the network-provisioning state change;  
receiving a request from the wireless device to initiate a programming session, establishing a programming session with the wireless device;

25  
30

obtaining an updated credential from a database, the updated credential associated  
with the wireless device;  
provisioning one or more network elements in accordance with the updated  
credential; and  
5 sending the updated credential to the wireless device.

## **ABSTRACT**

Devices, systems, and non-transitory computer-readable storage media for updating wireless device credentials, the wireless device comprising: a user interface, memory configured to store one or more credentials for enabling the wireless device to obtain one or more services over a wireless access network, and one or more processors configured to execute one or more machine-executable instructions that, when executed by the one or more processors, cause the one or more processors to obtain an indication of a user request to replace a particular credential with a target credential, detect a network-provisioning state change, determine that the particular credential does not match the target credential, initiate a programming session with a network element over a wireless access network, obtain an updated credential from the network element, and assist in storing the updated credential in memory.

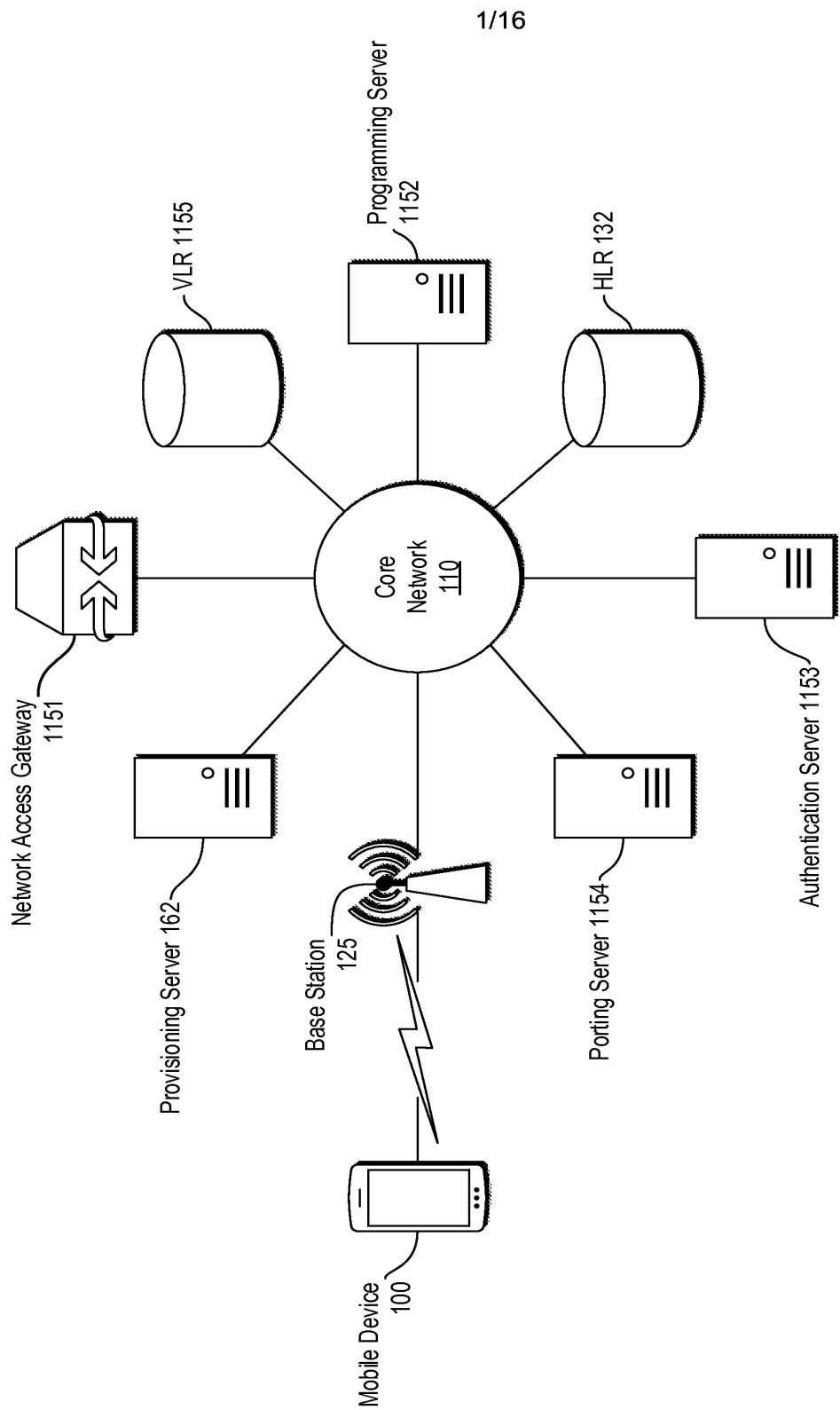

FIG. 1

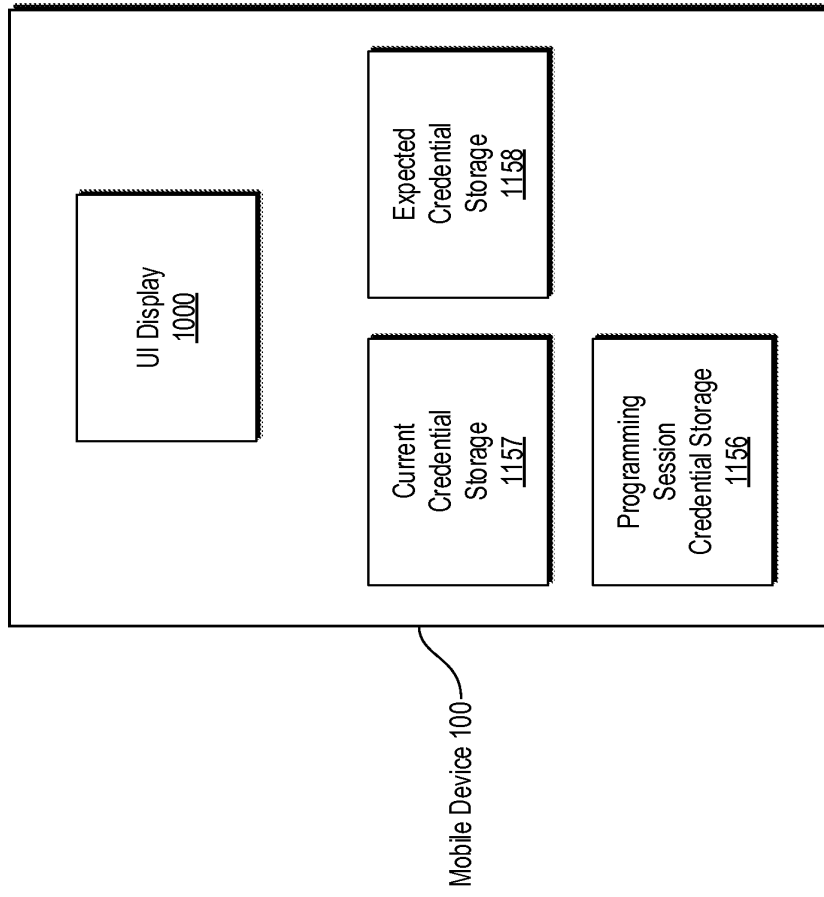
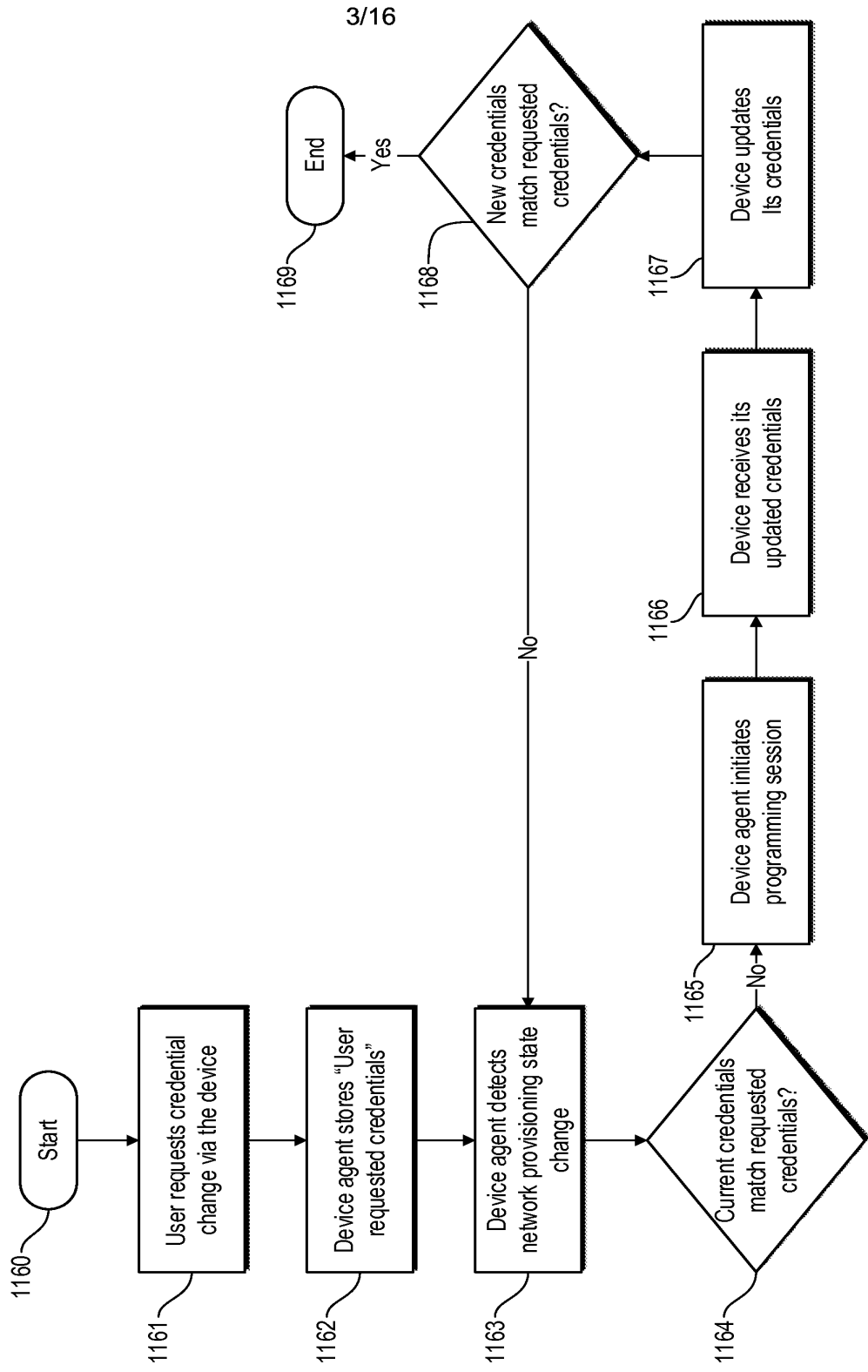

FIG. 2

FIG. 3



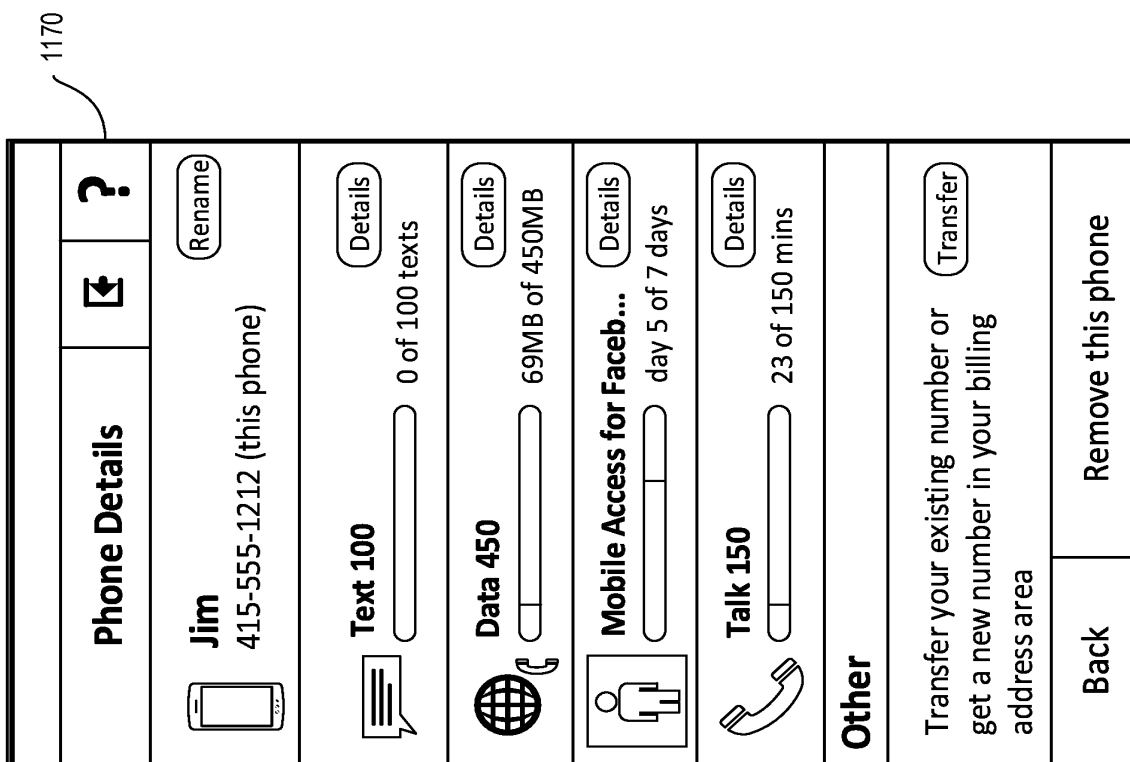

FIG. 4

1171

<b>Phone Number</b>	
<p>This device's current phone number: <b>415-555-1212</b></p> <p>You may choose to keep this phone number or change it. If you choose to keep it now, <b>it can always be changed anytime</b> from a device with the Admin role.</p> <p>Please select a phone number option:</p> <ul style="list-style-type: none"><li><input checked="" type="radio"/> Keep my phone number</li><li><input type="radio"/> Transfer my number from another phone</li><li><input type="radio"/> Give me a new phone number in my account's area code <small>(Based on the zip code you entered in the account information section)</small></li></ul>	
	<p>Continue </p>

FIG. 5

1172

<p><b>Phone Number</b></p>
<p><b>What you need</b></p> <p>Make sure you have:</p> <ul style="list-style-type: none"><li>* A copy of your last phone bill (recommended)</li><li>* Phone number to transfer</li><li>* First Name</li><li>* Last Name</li><li>* Street Number</li><li>* Street Name</li><li>* City, State &amp; Zip</li><li>* SSN or Account Number/Name</li></ul> <p>OK</p>

FIG. 6

1173

<b>Transfer your number</b>	
<p>The information below is required by your old carrier to transfer number to ItsOn Mobile.</p>	
<b>First Name (required)</b>	<input type="text"/>
<b>Last Name (required)</b>	<input type="text"/>
<b>Last Name</b>	<input type="text"/>
<b>Business Name</b>	or
<b>Business Name</b>	<input type="text"/>
<b>The mobile number you want to transfer (required)</b>	
<b>Phone Number (contact)</b>	<input type="text"/>
<b>Last 4 digits of Social Security Number or Tax ID (required if account number/name unavailable)</b>	
<input type="text"/>	
<b>Cancel</b>	

FIG. 7A

1174

<b>Transfer your number</b>	
<b>Billing Address</b>	
Street Number (required)	
<b>Street Number</b>	
Street Name (required)	
<b>Street Name</b>	
City (required)	
<b>City</b>	
State (required)	Zip Code (required)
<b>State</b>	<b>Zip</b>
<b>Your current carrier account information</b>	
Account Number/name (without dashes) (required if no SSN/Tax ID #)	
<b>Account #/name (no dashes)</b>	
<b>Cancel</b>	<b>Continue</b> 

FIG. 7B

1175

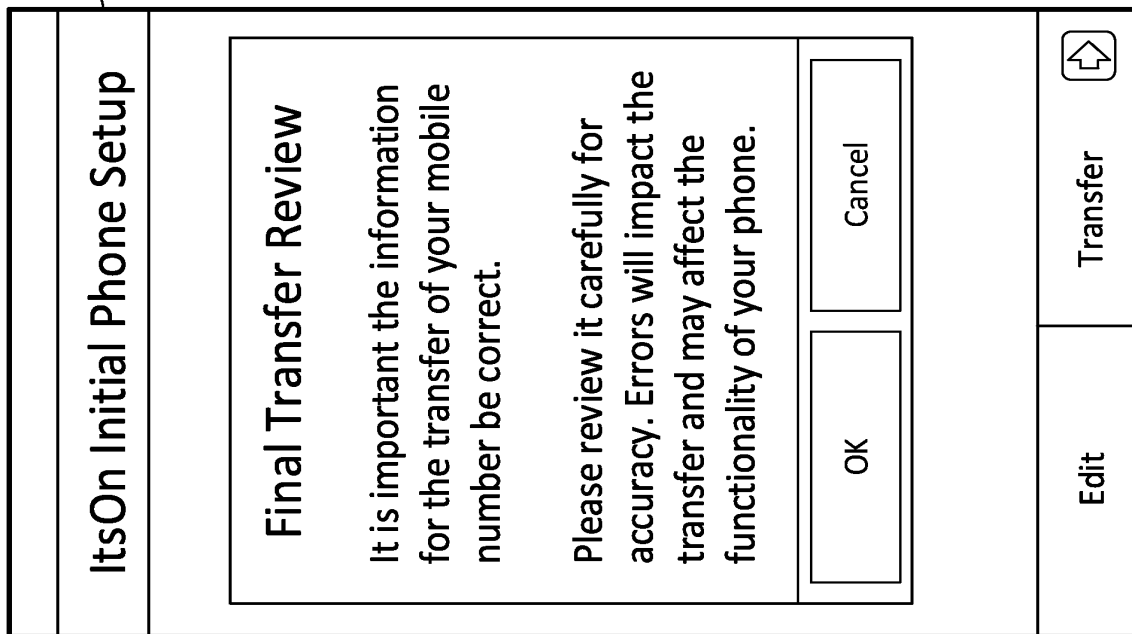

FIG. 8

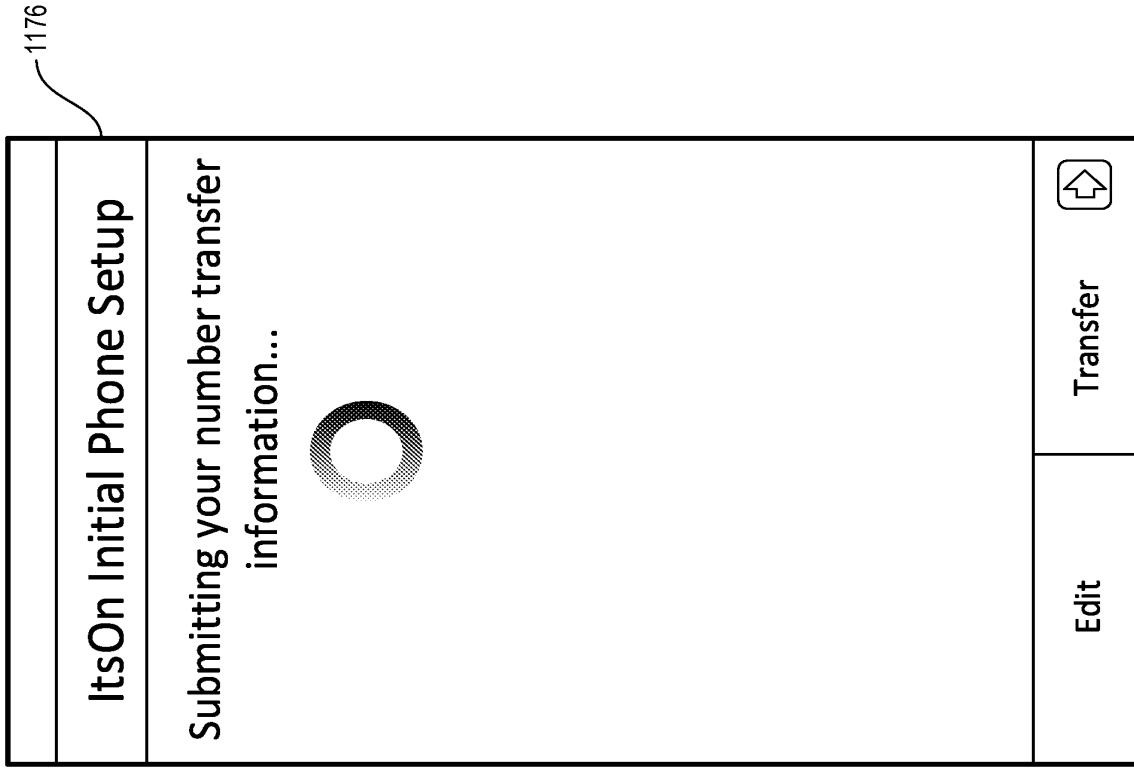

FIG. 9

1177

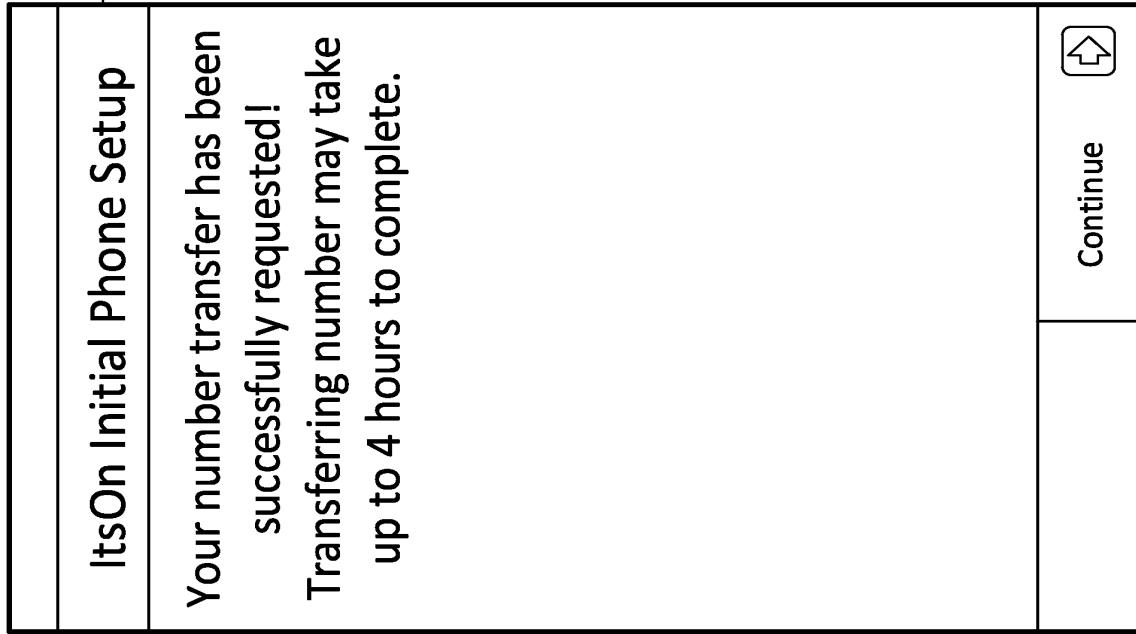

FIG. 10

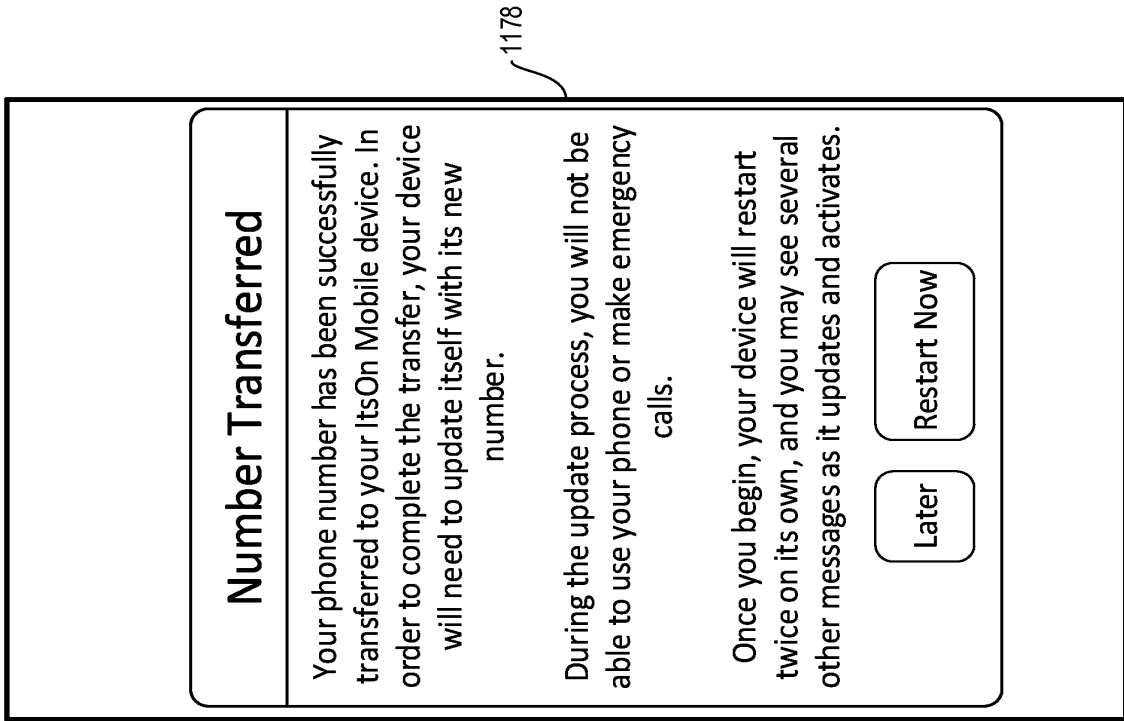

FIG. 11

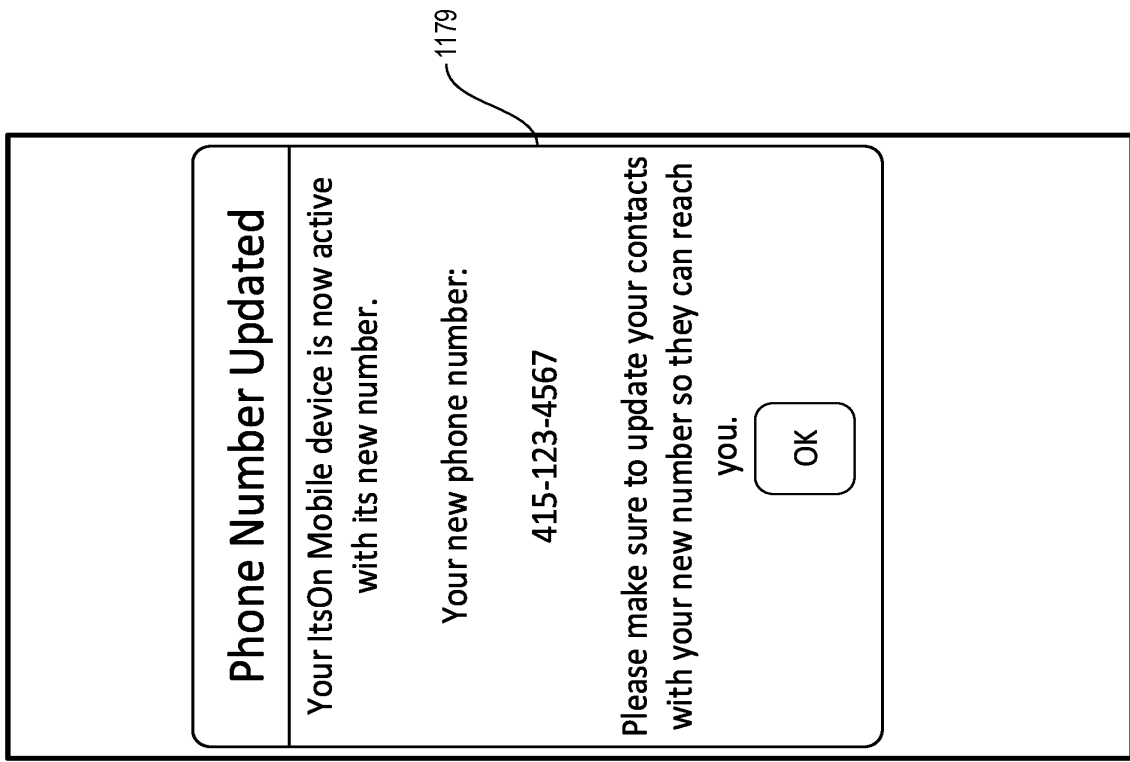

FIG. 12

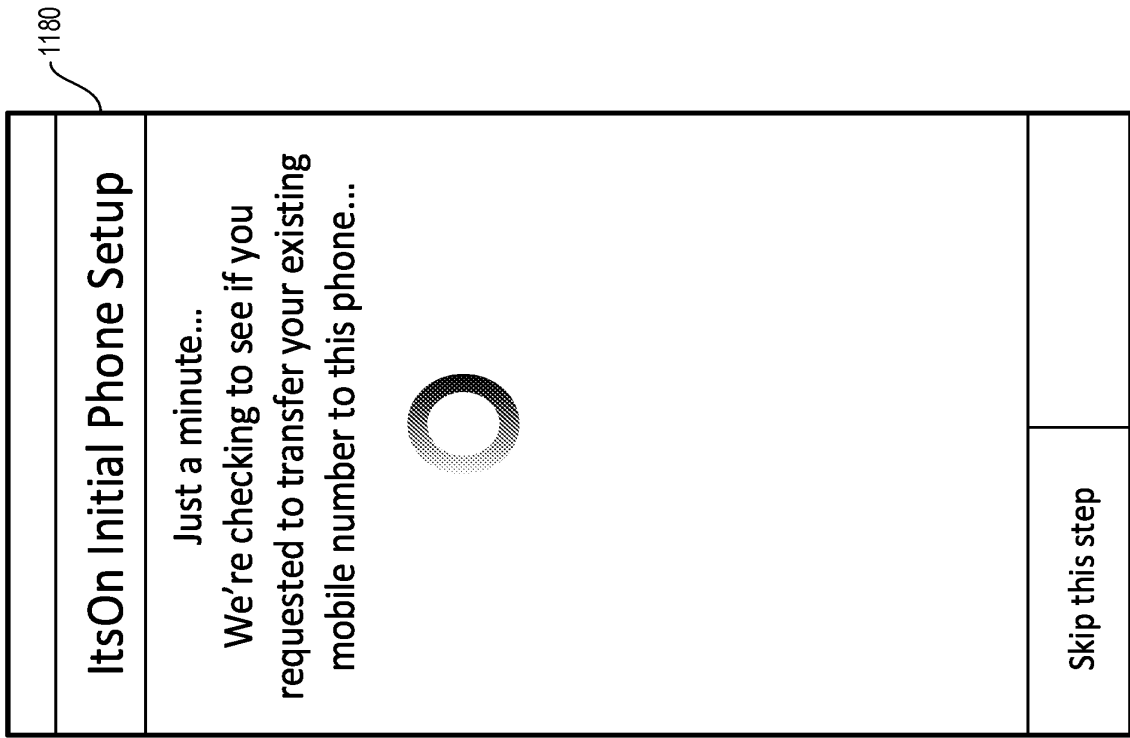

FIG. 13

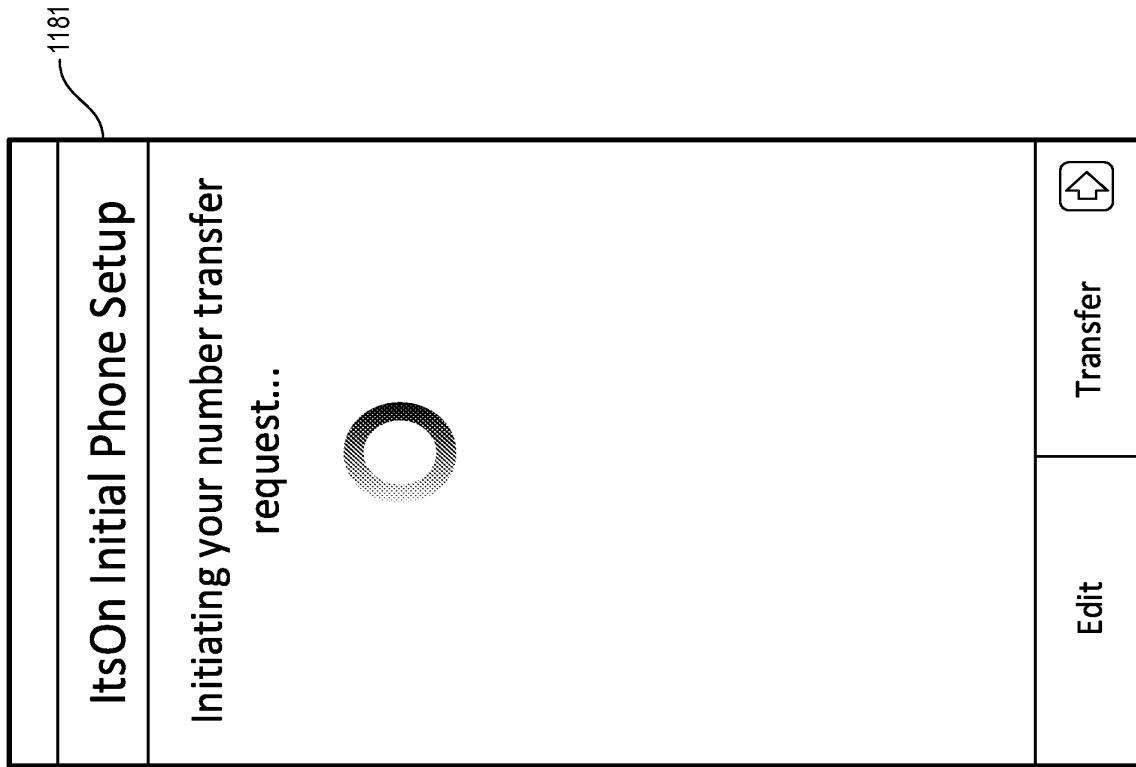

FIG. 14

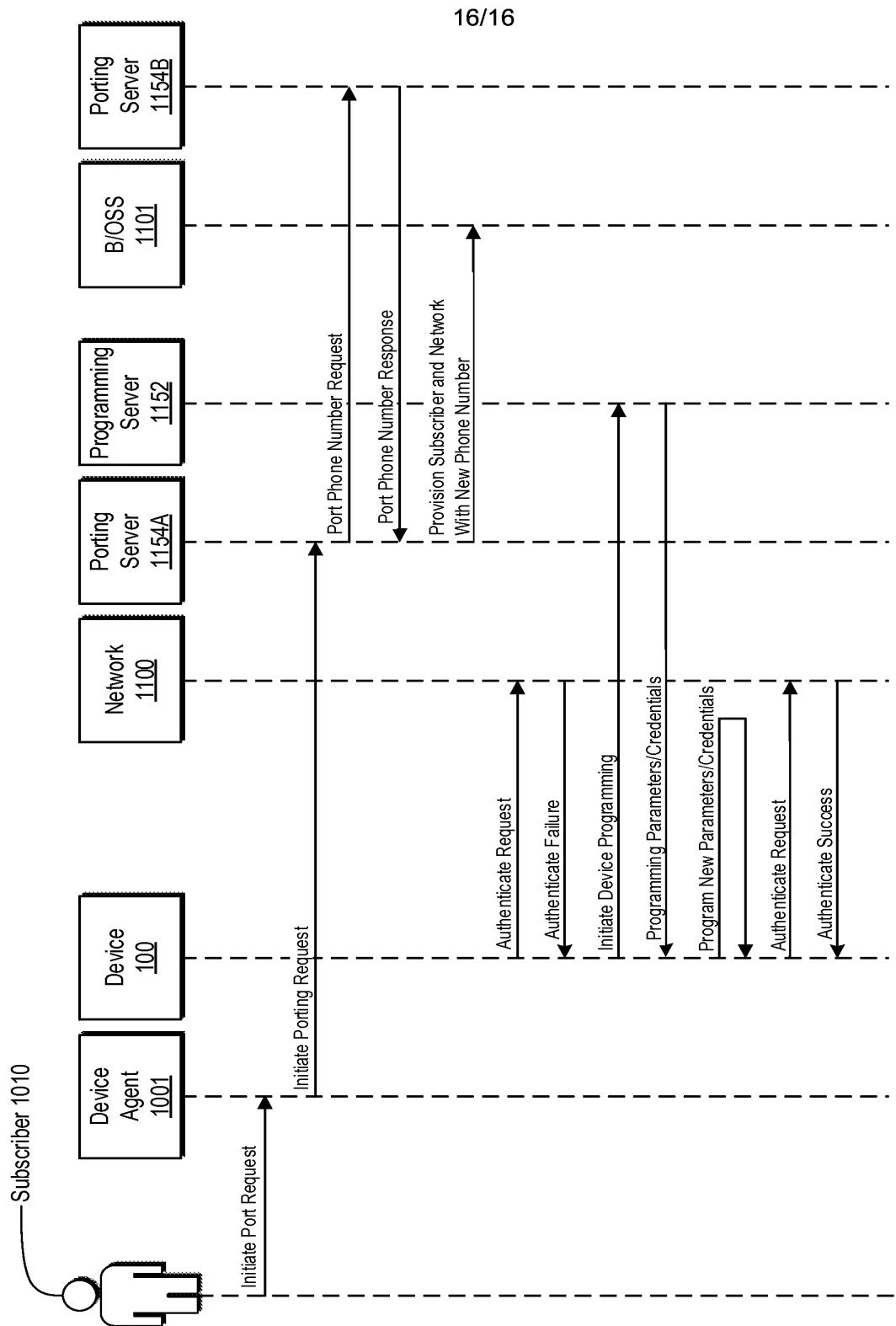

FIG. 15