

CASE IPR***
Patent No. 11,849,843

UNITED STATES PATENT AND TRADEMARK OFFICE

BEFORE THE PATENT TRIAL AND APPEAL BOARD

EP Family Corp.
Petitioner,

vs.

Office Kick, Inc.
Patent Owner.

IPR***
Patent No. 11,849,843

DECLARATION OF NATHAN J. MACDONALD

TABLE OF CONTENTS

I. INTRODUCTION2
II. QUALIFICATIONS2
III. INFORMATION REVIEWED.....3
IV. COMPENSATION4
V. FUNDAMENTAL CONCEPTS REGARDING INVALIDITY4
VI. BACKGROUND OF THE ASSERTED PATENT4
VII. LEVEL OF ORDINARY SKILL IN THE ART8
VIII. COMMENTARY ON CLAIM CONSTRUCTION10
IX. THE ASSERTED CLAIMS OF THE ASSERTED PATENT10
 A. ASSERTED CLAIMS OF THE '843 PATENT11
X. BACKGROUND ON THE PRIOR ART14
XI. INVALIDITY CHARTS28
XII. SECONDARY CONSIDERATIONS OF NONOBVIOUSNESS28
XIII. CONCLUSION.....29

I. INTRODUCTION

1. I have been retained as an independent expert witness in this *inter partes* review (IPR) by EP Family corp. (hereafter “EP Family”) to provide opinions and conclusions regarding the validity of US Patent No. 11,849,843 (hereafter “the ’843 patent”) to Mr. Nathan Mark Poniatowski. It is my understanding that EP Family has challenged the validity of the ’843 patent and has asked me to analyze and opine on this question of validity. In particular, I understand that at least claims 1-3, 6-14, 16, and 17 of the ’843 patent have been challenged (hereafter, “the challenged claims”). Consequently, I have limited my analysis and consideration to the challenged claims specifically. For reference, a diagram of the adjustable standing desk that is the subject of the Asserted Patent is shown below:

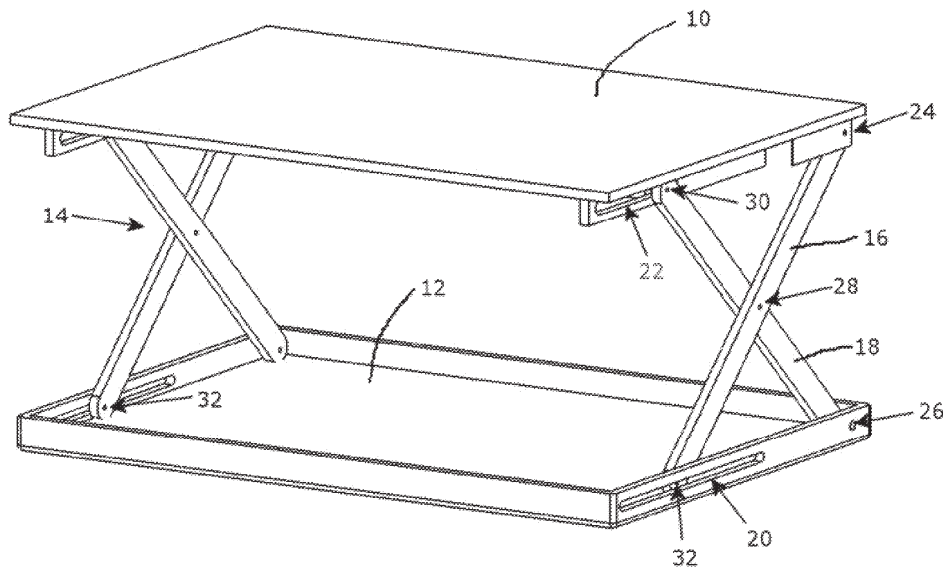

FIG. 1

1

II. QUALIFICATIONS

2. Attached as *Exhibit 1003* is a copy of my Curriculum Vitae, which outlines my educational and employment history. I am a registered Professional Engineer in the State of Utah (License

¹ ’843 Patent, Figure 1

no: 11829303-2202). I am also a Certified Safety Professional (CSP-38229) in comprehensive practice. I am also a certified commercial building inspector (Cert. No. 9679028). I am also a certified trainer for operators of Forklifts, telehandlers, and scissor lifts and other Mobile Elevating Work Platforms (MEWP's). I received my Bachelor of Science degree in Mechanical Engineering from Brigham Young University in 2014.

3. I have worked as a mechanical engineering consultant for Alpine Engineering & Design, Inc. for over 12 years. During that time, I have gained experience in the fields of mechanical engineering, design of aerial lifts, design of consumer products, structural design, design for manufacturing, and more. In my role as a consultant, I have taken part in the design and manufacture of numerous products, including exercise equipment, aerial lifts, amusement rides, consumer products, and more. Many of the products I have designed and/or analyzed have incorporated kinematic linkages such as those used in scissor lifts, springs, hydraulics, and the like. I have designed, built, and operated many different fluid-power systems, both manually actuated and electronically actuated. Based on my experience, education, training, and knowledge, I am an expert in the fields of mechanical design, structural design, hydraulics, pneumatics, safety, and manufacturing.

III. INFORMATION REVIEWED

4. I have reviewed many materials that informed the opinions contained herein. A list of information reviewed is attached hereto as *Exhibit 1005*.

5. My analysis in this matter is ongoing and subject to supplementation and modification as new materials are presented, discovered, and reviewed. I reserve the right to change or amend any opinions and conclusions expressed herein based upon new information, documents, testimony, and discovery.

IV. COMPENSATION

6. I am a salaried employee of Alpine Engineering and Design, Inc. They bill my time for expert witness work at \$300/hr. No part of my compensation depends on the outcome of this litigation.

V. FUNDAMENTAL CONCEPTS REGARDING INVALIDITY

7. I have been advised by counsel of the following concepts and have considered them in my examination of whether the Asserted Claims are valid or not. I have included a brief discussion of the legal concepts I have been informed of and understand as *Exhibit 1006*.

VI. BACKGROUND OF THE ASSERTED PATENT

8. As discussed previously, Nathan Mark Poniatowski is the named inventor on the Asserted Patent in the present matter. I have provided an additional declaration on a companion IPR regarding the validity of another patent (US 11,910,926) asserted by the Petitioner against the Patent Owner. Mr. Poniatowski filed US application 17/493,830 (now US 11,849,843, e.g. the '843 patent) on October 4, 2021. He filed application 17/985,137 (now US 11,910,926, e.g. the '926 patent) on November 10, 2022. The chart below outlines the lineage of these patents which have been asserted.

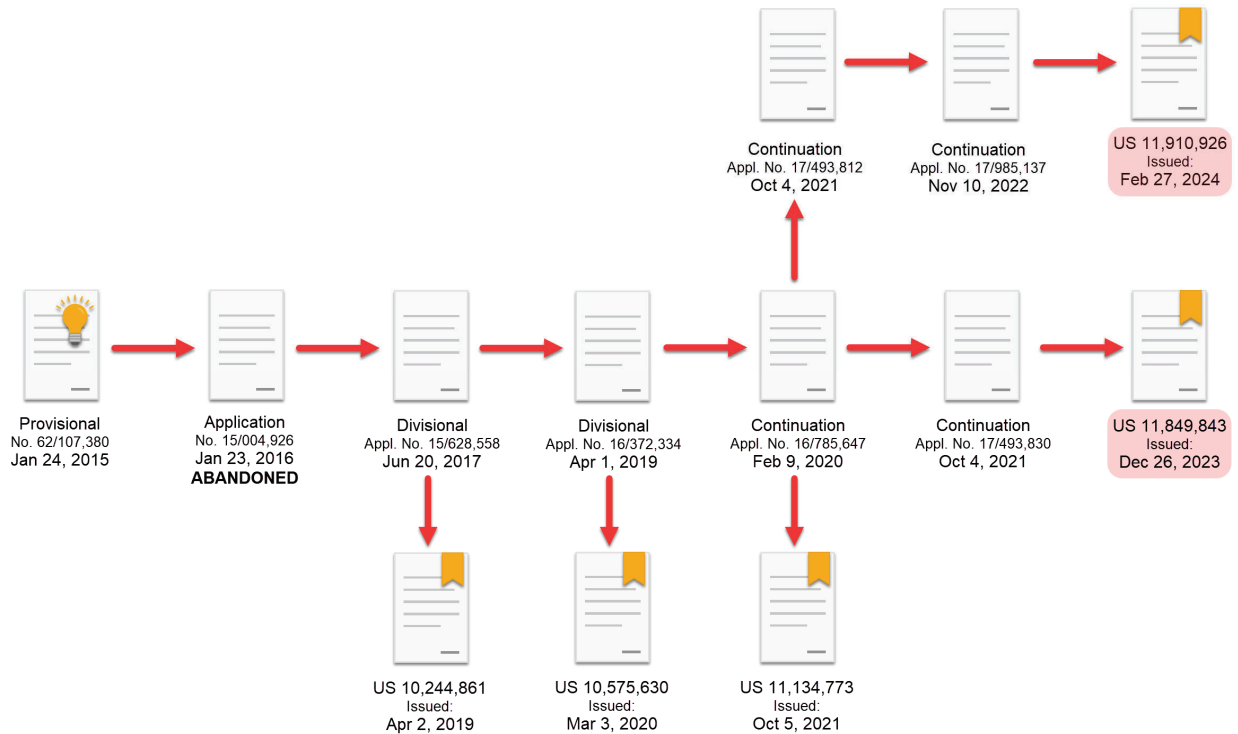

9. Amongst other things, the alleged invention disclosed in the '843 patent includes several embodiments. One such embodiment uses a locking gas spring to adjustably set the height of the common scissor lift mechanism that largely comprises the alleged invention.² Gas springs are off-the-shelf components which are easily incorporated into various mechanical designs as a matter of ordinary engineering practice. Gas springs of ordinary and customary design are produced in many different sizes and with different options and functionality. A common option for a gas spring is to have a locking device, an example of which is shown below:

² See '843 patent Figure 2D for example.

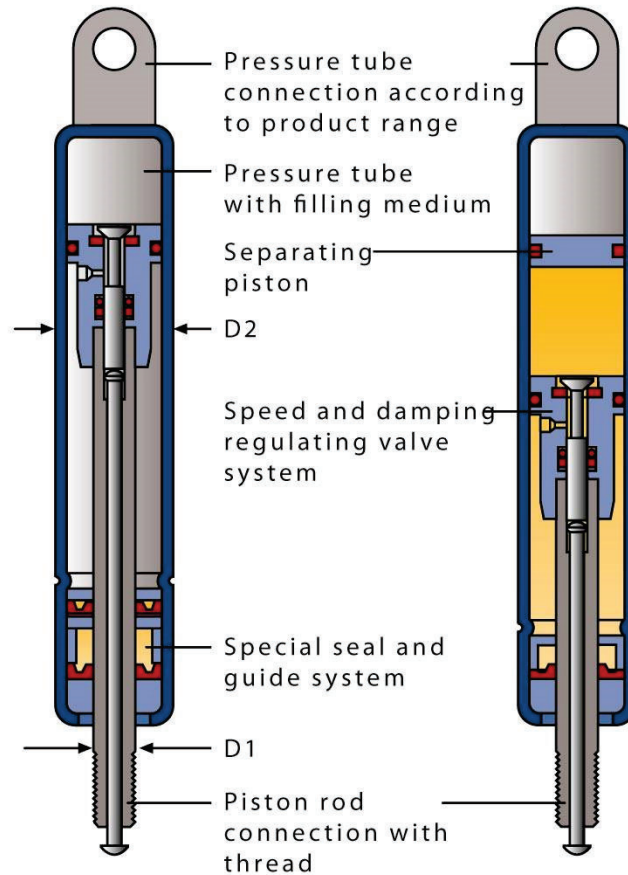

3

10. As shown above, a typical gas spring locking device consists of a poppet valve which alternately opens or closes an orifice between antagonistic chambers of the piston-cylinder arrangement. When it is closed (as shown on the left above) flow is blocked between chambers and the movement of the piston is restricted. When it is opened, a pathway is created between the antagonistic chambers which allows the gas spring to move and act as a normal gas spring.

11. A locking gas spring is an inexpensive off-the-shelf component that does not require any special design or undue experimentation to be incorporated. Rather, it is a matter of routine design practice and implementation accomplished by specifying a component that has been designed, tested, and manufactured by a third party.

³ <<https://www.enearossi.it/en/bloc-o-lift-locking-gas-spring/>> accessed Dec 29, 2024

12. I note that during the prosecution of the '843 patent, in order to overcome a rejection, the applicant argued that the locking device is a device that restricts motion rather than drives motion. For example, the meaning of “the gas spring acts as a locking device” is construed by the Applicant’s arguments dated September 30 2023, reciting that:

“Broder fails to disclose that pipe 61 is a locking device, instead disclosing it may be used as an exhaust or connected to the pressure source through a suitable valving arrangement if the cylinder is to be double action. A double acting cylinder is one that can apply a force in both extension and retraction. Such a feature is not equivalent to a locking mechanism as a locking mechanism instead inhibits motion rather than drive motion in any direction.”⁴

13. I note that in the correspondence above, the applicant cites the Broder reference (US6,220,558) but the citation is actually from US 3,282,566 to J.E. Clarke (hereafter “Clarke”). Clarke discloses a scissors operating linkage that is operated by a double acting hydraulic cylinder. As shown above, in an attempt to overcome a rejection, the applicant argued contrary to the disclosure of the '843 patent, which recites using a linear actuator as a locking device.

“The locking element can include, but not limited to, a linear actuator, a motor, applied pressure, locking teeth, or some other method to prevent arms 16 and 18 from moving, so that work surface platform 10 does not change vertical height. Applications utilizing a linear actuator or similar can allow the operator to adjust the height without the limitations of preset heights that some locking mechanisms only provide. Instead of preset heights created by an element with features such as preset holes, the linear actuator or something similar would allow the operator to set the height limit by stopping the linear actuator or similar at any point the operator chooses.” '843 6:62-7:6 (emphasis added)

14. As shown above, the applicant argued contrary to the disclosure of the '843 patent. Like a hydraulic cylinder, a linear actuator is a double acting element that can apply a force in both extension and retraction. A POSITA understands that linear actuators are generally provided as an electric alternative to a traditional hydraulic cylinder. There is no line of reasoning by which an argument can be made as to why a hydraulic cylinder is not a locking device, but a linear

⁴ 155431_17493830_2023-09-30_REM.pdf

actuator is. I further note that the applicant's arguments are disingenuous and contrary to even the characterization of a locking gas spring. It is well-known and easily understood that when a locking gas spring is unlocked, it acts as a gas spring, i.e. it exerts the force typical of a gas spring. As such a locking gas spring will drive motion and not just inhibit it, contrary to what the applicant stated during the prosecution of the '843 patent.

VII. LEVEL OF ORDINARY SKILL IN THE ART

15. I have been advised by counsel that factors that may be considered to decide the level of ordinary skill in the art include: (1) the educational level of the inventor, (2) the types of problems encountered in the art, (3) the prior art solutions to those problems, (4) rapidity with which innovations are made in the field, (5) the sophistication of the technology, and (6) the educational level of active workers in the field. Moreover, I have also been advised that a person of ordinary skill in the art is presumed to be knowledgeable of available prior art.

16. As discussed previously, the named inventor on the '843 patent is Mark Poniatowski. At the present juncture I have not been provided with Mr. Poniatowski's educational background.

17. The types of problems encountered in the art of vertically adjustable work surfaces include things such as follows:

- Materials choice
- Managing load capacity
- Mechanism topology selection
- Actuator selection, if applicable
- Managing mechanical advantage, depending on the type of linkage used
- Providing a suitable range of motion
- Managing power or force input/output

- Providing suitable fixturing
- Overall Mechanism stability
- Component stress evaluation and or life span
- Hardware selection
- Coatings selection
- Etc.

18. The prior art demonstrates a wide variety of materials choice, including steels, aluminums, plastics, wood, etc. As vertically adjustable work surfaces are disclosed for a wide variety of applications, the load capacity of various pieces of prior art has a wide variety. This includes small capacity tables⁵ as well as industrial sized hydraulic lifts⁶ and everything in between. The prior art shows a wide array of actuation including everything from actuation by hand⁷ to heavy hydraulic cylinders,⁸ gas springs,⁹ coil springs,¹⁰ and more. With such a rich history, many design tasks associated with the design and manufacture of vertically adjustable work surfaces amount to nothing more than ordinary and routine design tasks and procedures.

19. Innovations in the vertically adjustable work surface industry have typically been slow. The overall form and function of many such work surfaces remains largely unchanged. For example, the prior art is replete with scissor mechanisms used to vertically position work surfaces, dating back to at least as early as 1878 in US 200,057 to W. W. Hart. Many vertically adjustable work surfaces use a similar scissor mechanism to this day. On the whole, such work surfaces are fundamentally a quite simple technology, amounting to the ordinary combination of

⁵ US 200,057 to W. W. Hart (1878)

⁶ US 2,937,003 to Croll (1960)

⁷ US 200,057 to W. W. Hart (1878)

⁸ US 2,937,003 to Croll (1960)

⁹ US 3,444,830 to H. P. Doetsch (1969)

¹⁰ US 3,727,245 to Gerth (1973)

known linkages and actuators in known ways producing highly predictable results. Active workers in the field would typically be individuals with a bachelor's degree in mechanical engineering who may have only a few years of professional experience.

20. Having considered the factors described above, it is my opinion that at the time of the invention as disclosed in the '843 patent, a person having ordinary skill in the art of vertically adjustable work surfaces would have a bachelor's degree in Mechanical Engineering or another technical field and at least 2 years of experience in consumer product design. More industry experience could reduce the amount of educational experience required. I consider myself to have at least ordinary skill in the relevant art under this definition. I use that level of skill in making my observations and reaching my conclusions herein, unless otherwise stated.

VIII. COMMENTARY ON CLAIM CONSTRUCTION

21. I understand that claim terms are to be given their meaning as they would be understood by a POSITA in view of the intrinsic evidence. I understand that unless the intrinsic record indicates otherwise, claim terms are to be given their plain and ordinary meaning as they would be understood by a POSITA. I understand that the parties have agreed to construe the terms of the Asserted Claims as having their plain and ordinary meaning.

IX. THE ASSERTED CLAIMS OF THE ASSERTED PATENT

22. I have read and understand the specification, and claims of the Asserted Patent. As discussed previously, I understand that claims 1-3, 6-14, 16, and 17 of the '843 patent have been asserted by the Petitioner against the Patent Owner in a separate case (collectively "the Asserted Claims"). In the following analysis, the Asserted Claims are described as they would be understood by a person of ordinary skill in the art of vertically adjustable work surfaces at the time of the invention disclosed in the '843 patent.

A. **Asserted Claims of the '843 Patent**

Claim 1

1P. A desktop workspace that adjusts vertically, comprising:

1a. a work surface platform;

1b. a platform element sitting on the work surface platform, the platform element including an elevated platform surface above the work surface platform;

1c. a base configured to sit on an existing platform; and

1d. a height adjustment mechanism connecting the work surface platform and the base, the height adjustment mechanism including:

1d1. a first set of pivot arms that connect at a scissoring pivot point creating a scissoring motion when raising and lowering the work surface platform to various heights;

1d2. a second set of pivot arms;

1d3. an element that connects the first set of pivot arms to the second set of pivot arms;

1d4. a base pivot point fixed relative to the base and connecting the base and the first set of pivot arms;

1d5. a platform pivot point fixed relative to the work surface platform and connecting the work surface platform and the first set of pivot arms;

1d6. a sliding mechanism on an end of an arm of the first set of pivot arms between the end of the arm and either the work surface platform or the base;

1d7. a gas spring that assists in elevation of the work surface platform by applying a force to one of the first set of pivot arms as part of the scissoring motion,

1d8. wherein one end of the gas spring is fixed to the work surface platform, and wherein the gas spring acts as a locking device that holds the work surface platform at various vertical heights above the base; and

1d9. a handle that unlocks the locking device in response to pressure applied by a user.

Claim 2

2P. The desktop workspace of claim 1,

2a. wherein the platform element further includes four legs that support the elevated platform surface above the work surface platform,

2b. each of the four legs being proximate to one of four corners of the elevated platform surface.

Claim 3

3P. The desktop workspace of claim 1,

3a. wherein the platform element includes four sides including a bottom side on the work surface platform,

3b. a top side forming the elevated platform surface and two sidewalls that support the elevated platform surface above the bottom side and the work surface platform.

Claim 6

6P. The desktop workspace of claim 1,

6a. wherein the one end of the gas spring is fixed to the work surface platform via a bracket fixed to an underside of the work surface platform.

Claim 7

7P. The desktop workspace of claim 6,

7a. wherein the gas spring is attached directly to the one of the first set of pivot arms.

Claim 8

8P. The desktop workspace of claim 1,

8a. wherein the gas spring is attached directly to the one of the first set of pivot arms.

Claim 9

9P. The desktop workspace of claim 1,

9a. wherein the sliding mechanism is a first sliding mechanism,

9b. the desktop workspace further comprising a second sliding mechanism,

9c. wherein either the first sliding mechanism or the second sliding mechanism is attached or slides along the work surface platform,

9d. and the other of the first sliding mechanism and the second sliding mechanism is attached to or slides along the base.

Claim 10

10P. The desktop workspace of claim 1,

10a. wherein the scissoring motion when raising and lowering the work surface platform to various heights of the height adjustment mechanism moves the work surface platform in a straight vertical direction relative to the base.

Claim 11

11P. The desktop workspace of claim 1,

11a. wherein the sliding mechanism includes a wheel mounted on the end of the arm of the first set of pivot arms.

Claim 12

12P. The desktop workspace of claim 1,

12a. wherein the base pivot point is a first base pivot point,

12b. wherein the height adjustment mechanism further includes a second base pivot point fixed relative to the base and connecting the base and the second set of pivot arms, and

12c. wherein the base includes one or multiple stationary pieces of material connecting the first and second base pivot points to one another.

Claim 13

13P. The desktop workspace of claim 1,

13a. wherein the gas spring is attached to the one of the first set of pivot arms via an arm pivot point.

Claim 14

14P. The desktop workspace of claim 1,

14a. wherein the element that connects the first set of pivot arms to the second set of pivot arms is attached on the same sides of the arms as the sliding mechanism relative to the scissoring pivot points.

Claim 16

16P. A desktop workspace that adjusts vertically, comprising:

16a. a work surface platform;

16b. a platform element sitting on the work surface platform, the platform element including an elevated platform surface above the work surface platform;

16c. a base configured to sit on an existing platform; and

16d. a height adjustment mechanism connecting the work surface platform and the base, the height adjustment mechanism including:

16d1. a first set of pivot arms that connect at a scissoring pivot point creating a scissoring motion when raising and lowering the work surface platform to various heights;

16d2. a second set of pivot arms;

16d3. an element that connects the first set of pivot arms to the second set of pivot arms; a base pivot point fixed relative to the base and connecting the base and the first set of pivot arms;

16d4. a platform pivot point fixed relative to the work surface platform and connecting the work surface platform and the first set of pivot arms;

16d5. a sliding mechanism on an end of an arm of the first set of pivot arms between the end of the arm and either the work surface platform or the base; and

16d6. a gas spring that assists in elevation of the work surface platform by applying a force to one of the first set of pivot arms as part of the scissoring motion,

16d7. wherein one end of the gas spring is fixed to the work surface platform,

16d8. wherein the gas spring acts as a locking device that holds the work surface platform at various vertical heights above the base, and

16d9. wherein the gas spring, the first set of pivot arms, the base pivot point, and the platform pivot point align side-by-side when the desktop workspace is in a fully lowered position such that the desktop workspace adjusts vertically.

17P. The desktop workspace of claim 16,

17a. wherein the gas spring is a first spring,

17b. the desktop workspace comprising a pair of springs attached to the height adjustment mechanism to assist in the elevation of the work surface platform,

17c. the pair of springs including the first spring and a second spring.

X. BACKGROUND ON THE PRIOR ART

23. As will be demonstrated for multiple reasons, it is my opinion that the apparatus depicted in the Asserted Patent is not inventive whatsoever. Specifically, it is my opinion that the vertically adjusting desktop workspace is merely the combination of ordinary and well-known design elements in ordinary and well-known ways producing predictable results. There is a

tremendous amount of analogous prior art in the field of vertically adjustable work surfaces. It is my opinion that a POSITA would find the following pieces of prior art are particularly relevant rendering the claimed apparatus obvious to produce. As will be shown below, many of these pieces of prior art were inappropriately not disclosed to the examiner during the prosecution of the Asserted Patent. It is my opinion that had these pieces of prior art been disclosed, it is unlikely that the Asserted Patent would have ever been allowed to issue.

24. I note that at least 335 references were disclosed to the examiner during the prosecution of the '843 patent. This is a relatively large number of patents and it would be very easy and foreseeable for an examiner to miss potentially important references with so many to go through. The table below is a brief orientation to the pieces of prior art that I believe render the Asserted Claims obvious to a POSITA.

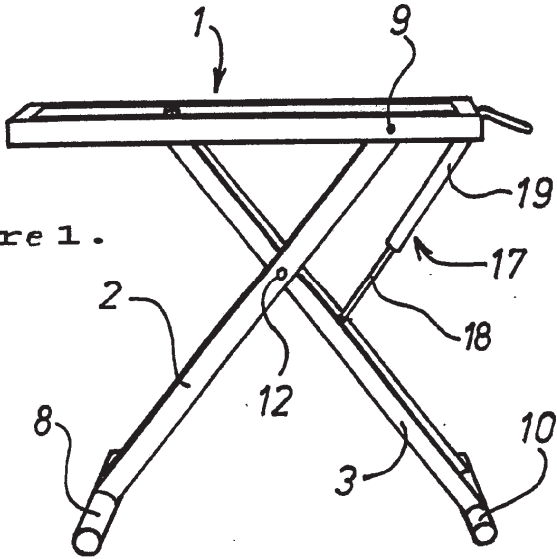
Prior Art Reference	Commentary
<p>WO 9117906 to Lindahl (hereafter, "Lindahl") November 28, 1991 NOT BEFORE THE EXAMINER</p>  <p>Figure 1.</p>	<p>Lindahl discloses a continuously adjustable scissor lift platform. Lindahl discloses the use of a locking gas spring, a common off-the-shelf component that interacts with a scissor leg mechanism. The locking gas spring thus allows the platform to be set at any desired height. Lindahl discloses the use of a simple handle to lock or unlock the gas spring. Lindahl further demonstrates how a POSITA would readily understand the interchangeability between a hydraulic cylinder and a locking gas spring.</p>
<p>The following citations provide a brief synopsis of the Lindahl mechanism:</p> <p><i>"...the stand includes at [least] two leg members (2, 3) which are hinged or pivotally connected together such as to enable the parts of leg members located on mutually opposite sides of the hinge or</i></p>	

pivot (12) to be moved towards and away from one another in a scissor-like fashion.” Lindahl, Abstract

“a gas-spring, or piston-cylinder device (17), so arranged in the stand as to enable the frame-like part (1 of said stand to be adjusted vertically, both downwardly and upwardly, wherein the gas-spring can be blocked in the set position so as to maintain the position of the frame-like part and therewith the position of the tabletop in relation to the underlying supporting surface.” Lindahl, Abstract

“The stand includes at least two leg members which are hinged or pivotally connected together such as to enable the parts of said leg members located on mutually opposite side of the hinge or pivot to be moved towards and away from one another in a scissor-like fashion.” Lindahl 1:30-35

“A gas-spring, or piston-cylinder device, so arranged in the stand as to enable the frame-like part of said stand to be adjusted vertically, both downwardly and upwardly, wherein the gas-spring can be blocked in its position, so as to maintain the position of the frame-like part and therewith the position of the tabletop in relation to the underlying supporting surface. This enables the frame-like part, and therewith the tabletop, to be adjusted continually to any selected vertical position, in which position the gas-spring is locked.” Lindahl 2:12-22

“The stand includes a frame-like part 1 which is carried by two leg member 2, 3. Each leg member 2, 3 includes two substantially parallel rods or bars 4, 5; 6, 7 wherein the two parts of each pair of bars are spaced from one another and are connected together at both ends thereof by means of a respective transverse rod.” Lindahl 3:3-7

“The on rod 9 is pivotally mounted in the bars 14, 15 whereas the other transverse rod 11 is provided at both ends with suitable means for sliding in the U-shaped part of the bars in order to achieve the aforesaid scissor-like movement of the leg members.” Lindahl 3:33-4:3

“The gas-spring 17 is provided with a centrally positioned pin 20 which protrudes slightly from the upper part 19 of the gas-spring in an axial direction. This pin 20 is intended to activate a release valve provided within the gas spring.” Lindahl 4:17-21

“The operating means 24 has an elongated shape and has a handle 26 provided on the rear thereof and a part 27 which function to engage the end of the pin 20 on the front thereof.” Lindahl 5:8-11

US 4,574,785 to Yamamoto (hereafter, “Yamamoto”) March 11, 1986

NOT BEFORE THE EXAMINER

Yamamoto discloses a scissor lift platform where the scissor mechanism is operable from a completely collapsed arrangement to a fully deployed arrangement. The Yamamoto apparatus is applied to a medical bed; however, a POSITA would easily understand that such a scissor lift surface has broader applications. The main focus of Yamamoto is on the controls system and on the fluidized bed itself. The scissor lift mechanism itself is so mundane that it’s not a major point of focus.

FIG. 2A

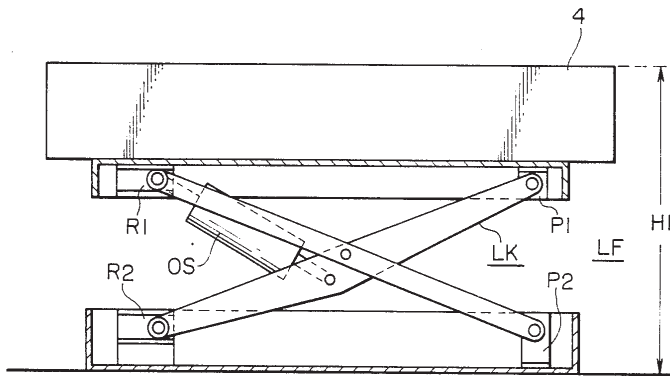
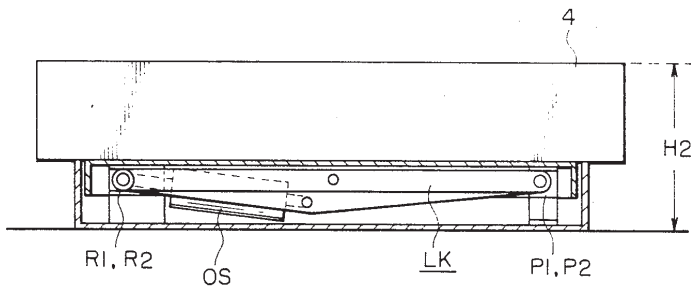

FIG. 2B



It is my opinion that the same is true of the Asserted Patent. There is absolutely nothing inventive in the Asserted Patent whatsoever. The use of a scissor mechanism was well known. The use of gas springs to assist linkages such as scissor lifts was well known. The apparatus described in the Asserted patent is the mere combination of very simple elements in known ways producing mundane results. A POSITA would easily recognize that the hydraulic cylinder could be swapped for a locking gas spring. Further, a POSITA would recognize that making this adjustment would provide advantages in simplifying the lift mechanism to no longer need the external hydraulics system.

The following citations provide a brief synopsis of the Yamamoto mechanism:

“The conventional fluidized bed has a fixed height. However, there has been a demand for a fluidized bed having an adjustable height, specifically, one in which the height of the bed above the floor can be made as small as possible for ease in transferring a patient onto the bed or when a patient gets onto or off the bed, and placed at a suitable height when the patient is lying on the bed for administering treatment to the patient.” Yamamoto 1:53-60

“FIG. 2 illustrates the arrangement of such a mechanism for producing vertical movement. The height of the fluidized bed, and hence the height of the tank 4, are freely adjustable by a lifter LF between a maximum height H1 and a minimum height H2. The lifter LF includes a link mechanism LK having bearings P1 and P2 fixed to ends thereof and rollers R1 and R2 on opposite ends thereof which are movable along a guide rail.” Yamamoto 1:63-2:3

US D308,537 to Clark (hereafter, “the ’537 patent,” or Clark”)
 June 12, 1991
NOT BEFORE THE EXAMINER

Clark discloses the ornamental appearance of a computer printer stand. Despite that Clark itself can only cover the ornamental appearance of the article of manufacture that is a printer stand, a POSITA would easily recognize the utilitarian features of the printer stand as being an elevated platform on which objects including

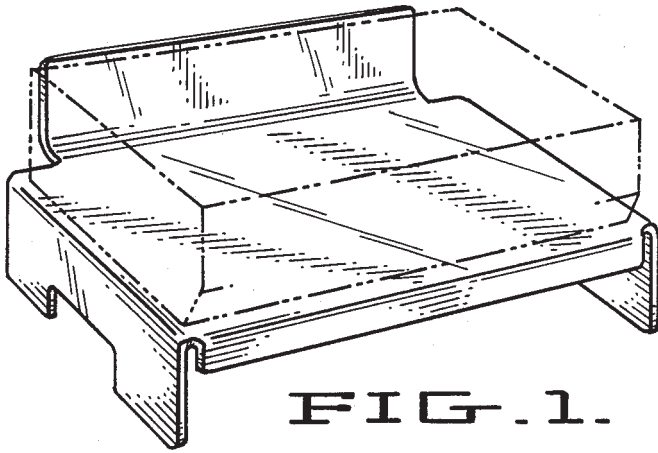

electronics can be supported at a height that enhances their ease of use. Clark shows a design for a platform that is generally rectangular in shape and is provided with four support legs generally positioned at the corners of the platform. A POSITA would easily recognize that such a platform could advantageously be placed on a desk or table of any type including an elevating work platform.

US 3,282,566 to Clarke (Hereafter, "Clarke")
 May 18, 1964
 Before the Examiner, cited in a prior rejection

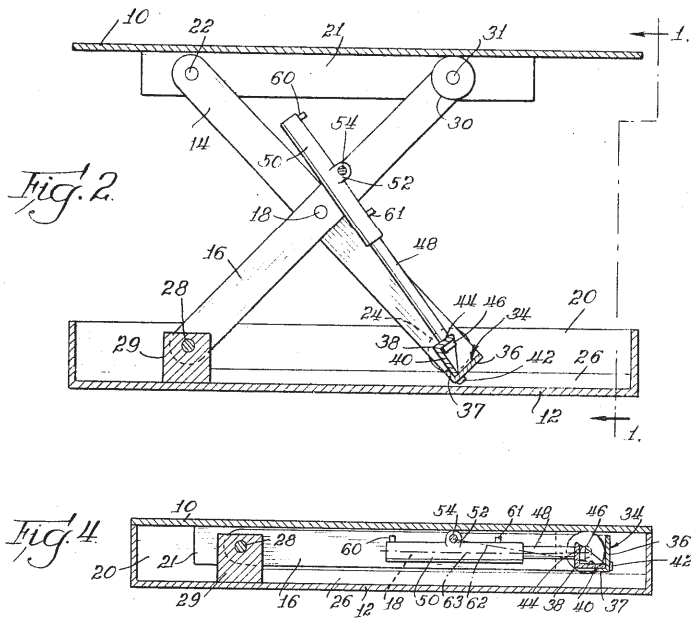

Clarke discloses a scissor lift mechanism for vertically lifting a table from a stowed position to an open position. In particular, Clarke is aimed at addressing the well-known problem that can occur in actuated scissor lift mechanisms of lifting from a completely flat orientation. In typical scissor lift mechanisms, if they are allowed to collapse to a perfectly flat, it can create infinite mechanical advantage *against* the actuator, making it impossible for it to lift the upper platform without the assistance of some other mechanism. Many scissor lift mechanisms solve this problem by never allowing a linkage to go completely flat. However, this detracts from one of the main advantages of a scissor mechanism which is how compact it can become when stowed. Clarke proposes an eccentric trunnion mounted cylinder which allows the actuator to develop a vertical lift force even when the linkage is fully collapsed. A POSITA would easily recognize that the hydraulic cylinder could be swapped for a locking gas spring. Further, a POSITA would

	<p>recognize that making this adjustment would provide significant advantages in simplifying the lift mechanism to no longer need the external hydraulics system.</p>
<p>The following citations provide a brief synopsis of the Clarke mechanism:</p> <p><i>“This invention relates to the operation of a scissors lift in changing it from a down or closed position to up or open position. It is particularly employed in connection with lift tables and the like.” Clarke 1:8-11</i></p> <p><i>“In the present invention, by mounting a hydraulic cylinder so that the mounting points are substantially offset from the axis of the cylinder, a component of force is obtained on the mounting points with the -component being norm-al to the axis of the cylinder. This component is employed to open the closed scissors linkage. A principal object of the invention is therefore to eliminate the extra cams, or rollers, etc., normally employed to start the movement of a scissors lift from the closed position. A simple hydraulic cylinder is employed for all phases of the lifting or operation of the scissors linkage.” Clarke 1:14-26</i></p> <p><i>“Referring now more particularly to the drawings, the invention comprises a lift table having a top and a base 12 connected by crossed scissors legs 14 and 16 at each side. Legs 14 and 16 are pivotally connected at 18. As shown, the base 12 is in the form of an open shallow box or receptacle having upright sides 20, and the top 10 fits down closely upon the sides enclosing all the operating parts, as shown in FIG. 4.” Clarke 1:67-2:2</i></p> <p><i>“Depending from the top, at each side, is a plate 21. A pivot 22 near one end of the plate 21 connects the upper end of the leg 14 to the plate. Leg 14 has a roller 24 rotatably mounted at the other end on shaft 25. Roller 24 rides on the upper surface of a strip 26 in the bottom of one side of the base 12. One end of the other leg 16 has a pivot 28 connecting it to a support block 29 directly below the pivot 22 for the leg 14. A roller 30 mounted on shaft 31 at the other end of leg 16 rides on the underside of the table top 10. The legs are closely folded together by the pivot 18 intermediate their ends, for parallel scissor action between the base and the top.” Clarke 2:3-14</i></p>	
<p>US 2014/0041554 to Huang (hereafter “Huang”) February 13, 2014 NOT BEFORE THE EXAMINER, subsequent issued patent with a later published date was before the examiner but not cited</p>	<p>Huang discloses a height-adjustable scissor lift table of ordinary design. Huang discloses the use of a locking gas spring (which it refers to as a “air pressure bar”) that can be selectively locked and unlocked through the use of a handle. In particular, Huang configures the structural elements of the sliding mechanism to reinforce the structural strength of the table. A POSITA would recognize that an air pressure bar refers to a gas spring. This fact is made clear in the figures that illustrate the air</p>

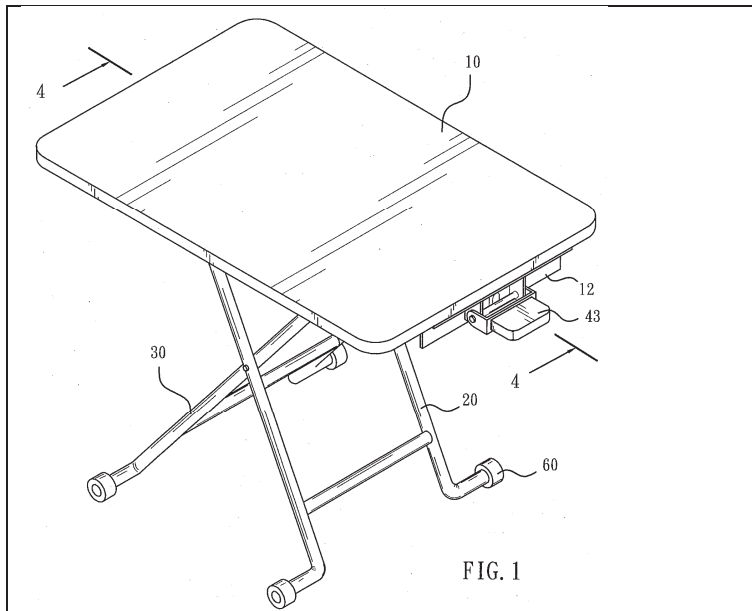

pressure bar as a simple piston-cylinder device with no inlet and outlet ports typical of a gas spring.

The following citations provide a brief synopsis of the Huang mechanism:

“Later, another adjustable table with an air pressure bar as an adjusting device was invented, wherein the air pressure bar is applied for achieving the goal of speedily and continuously adjusting.” Huang 0005

“A height-adjustable table includes a table board, a first foot, a second foot, an air pressure bar and an assistant device. The first foot crossly and pivotally connects with the second foot, wherein one end of the first foot pivotally connects with a first fastener on the bottom side of the table board, and one end of the second foot pivotally connects with a pivot joint. The assistant device is fixed between the first fastener and a second fastener, wherein one end of the air pressure bar is fixed on the second fastener while the other end fixed on the assistant device. Therefore, when the air pressure bar is operated, smooth sliding of the air pressure bar is provided, whereby the structural strength of the table is reinforced.” Huang, Abstract

“For this objective, the present invention as an adjust able table with an assistant device comprises a table board, with a first fastener and a second fastener on the bottom side; a first foot pivotally connecting to the first fastener, a second foot pivotally connecting to the first foot; a pivot joint pivotally connecting to one end of the second foot; an air pressure bar is installed between the first fastener and the second fastener, wherein the air pressure bar possesses a stretching rod and a rod body, with one end of the stretching rod fixed on the second fastener, a lever pivotally connecting to the second fastener thereby controlling the operation of the air pressure bar; an assistant device comprising at least one sliding Stick positioned between the first fastener and the second fastener; a sliding member slidely disposed around the sliding Stick; and a combining piece fixed on one end of the sliding member and one end of the body of the air pressure bar simultaneously, wherein the sliding member together with the body of the air pressure bar relatively displace against the sliding Stick when the air pressure bar is operated, in order to change the angle included by the first foot and the second foot, whereby height of the table is adjusted and the smooth sliding of the

air pressure bars provided; in addition, the structural strength of the table is reinforced.”
Huang [0007]

CN203934825 to Zhang (hereafter “Zhang”)
May 26, 2014

Before the examiner, not cited



图 4

Zhang discloses an elevated work surface platform that can be continuously adjusted to a variety of heights and locked in place. Zhang describes the use of a pair of locking gas springs (which it refers to as driving air rods) to facilitate this adjustment and support. The locking gas springs are of ordinary design. Zhang further describes a Bowden cable based arrangement with a handle which can be used to selectively unlock or lock the gas springs. When the gas springs are unlocked, they exert an outward assistive force which aids in lifting the work surface platform. Zhang also describes a turntable which allows the tabletop portions to be swiveled and unfolded. Thus, Zhang teaches a design which can be stored very compactly when not in use.

“Currently, tables on the market that are supported by “X” – shaped cross metal feet usually have a fixed height on the tabletop. As the tabletop height cannot be adjusted, it cannot be adjusted to the appropriate height according to the user’s needs, and it is also inconvenient to reduce the space occupied for storage after folding. ... The purpose of this utility model is to overcome the problems existing in the prior art and provide a height-adjustable table.” Zhang [0002-3]

“The purpose of the present utility model is achieved as follows: a height-adjustable table, comprising a tabletop (1), a stand (2), and an “X” - shaped cross movable metal foot (3).” Zhang [0004]

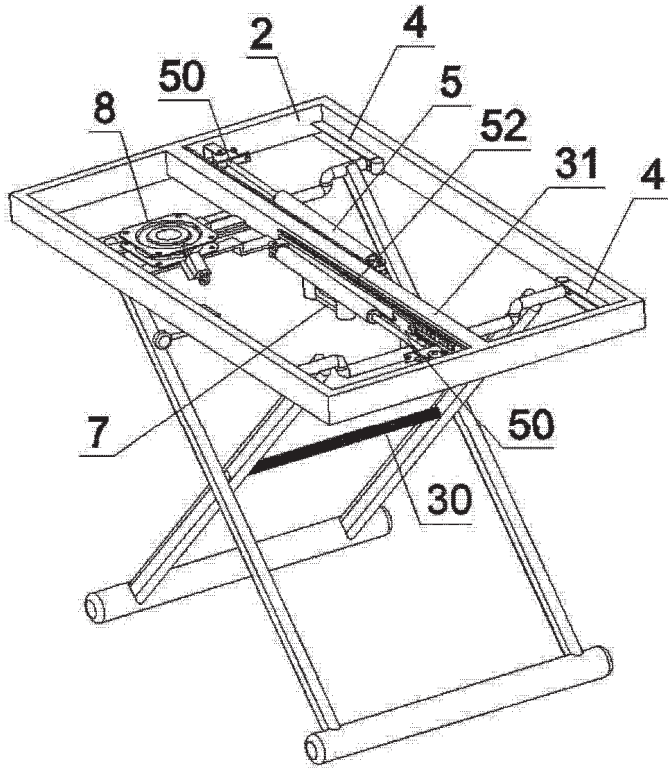
“The platform (2) has not yet opened the upper ends of the “X” - shaped cross movable metal feet (3) to both sides to prevent the rapid lowering of the desktop (1), and the elastic buffering mechanism (7) is fixed in the middle of the platform (2), with the lower end facing the pivot shaft (30) in the middle of the “X” - shaped cross movable metal feet (3).” Zhang [0005]

“On one side of the platform (2), there is a swing rod (12) that drives the action of the cable switch (6). The middle of the swing rod (12) is fixed to a fixed frame (12) through a rotating shaft (11). The cable drive end of the cable switch (6) is connected to one end of the swing rod (12). When the swing rod (12) swings, the valve of the driving air rod (5) is opened, and the movable rod end (50) is in a telescopic state; When the swing rod (12) is in a nonstressed state, the valve of the driving air rod (5) is closed, and the movable rod is in a positioning state” Zhang [0007]

“The positive effect of this utility model is that the height adjustable table using this structure can control the opening angle of the "X" - shaped cross movable metal feet through the joint action of horizontal guide rails, air support rods, pull switches and other components to adjust the height of the desktop and perform height positioning, making it very convenient to adjust the desktop height.” Zhang [0009]

25. Cumulatively the prior art teaches many different arrangements for scissor lift linkages and lift tables are possible. The scissor lift was invented at least as early as 1845 actuated by a steam engine. In 1846, the first industrial hydraulic lifting tables were produced.¹¹ Then other powered lifts soon followed. In the 1920s, hydraulic lifts were pulled on cars in Sweden to fix streetlights.¹²



26. With US 3,246,876 to Charles Larsen an early US patent was filed in 1963. Larsen included two elongated extensible-contractable rams to actuate the scissor lift. See figure below.

¹¹ <<https://www.fortranmachinery.com/news-show-902017.html>> accessed Jan 2, 2025

¹² <<https://www.hybridlifts.com/ansi/GoHyer/2021/History-of-Scissor-Lifts.htm>> accessed Jan 2, 2025

¹³ <<https://www.hybridlifts.com/ansi/GoHyer/2021/History-of-Scissor-Lifts.htm>> accessed Jan 2, 2025

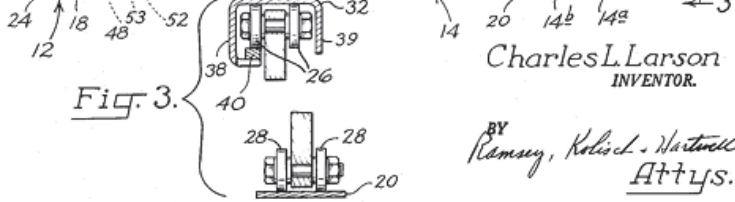
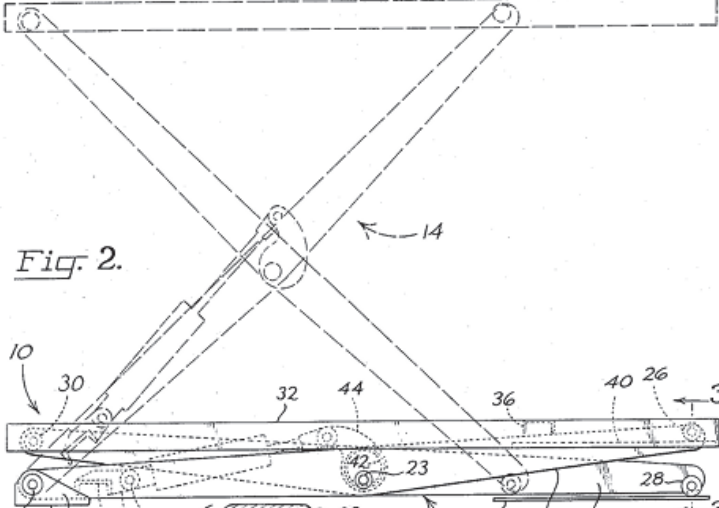
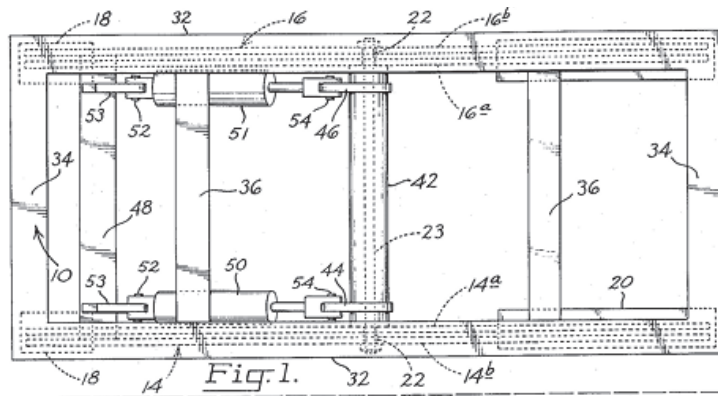

14

“Upward movement of the platform is produced by actuation of some power-operated means, such as an extensible ram. A more specific object of this invention is to provide an improved lift mechanism, featuring novel structure incorporating an extensible means, such as a ram, in the mechanism, whereby a relatively large amount of upward extension is possible with a relatively short ram.” Larsen 1:29-36

27. Modern lift tables are now very common and are used in many industrial applications. Some of these devices are designed to lift as much as 3 Tons. Two of these types of devices are shown below:

¹⁴ US 3,246,876 to Charles Larsen Figures 1-3



15



16

28. I note that each of the scissor lifts above also show the use of a pair of pivot arms and further a pair of fluid power cylinders to raise and lower the lift table as opposed to a single set.

¹⁵ <https://www.fortranmachinery.com/upload/6692/1-ton-fixed-roller-type-lifting-table_327552.jpg> accessed Jan 2, 2025

¹⁶ <https://en.wikipedia.org/wiki/Lift_table#/media/File:TL_2000_scissor_lift.jpg> accessed Jan 2, 2025

This is typical and customary in the design of scissor lift linkages. US 2004/0040480 filed in 2002 by Sunny Hwang demonstrates incorporating scissor lift linkages into ordinary office desks as shown below:

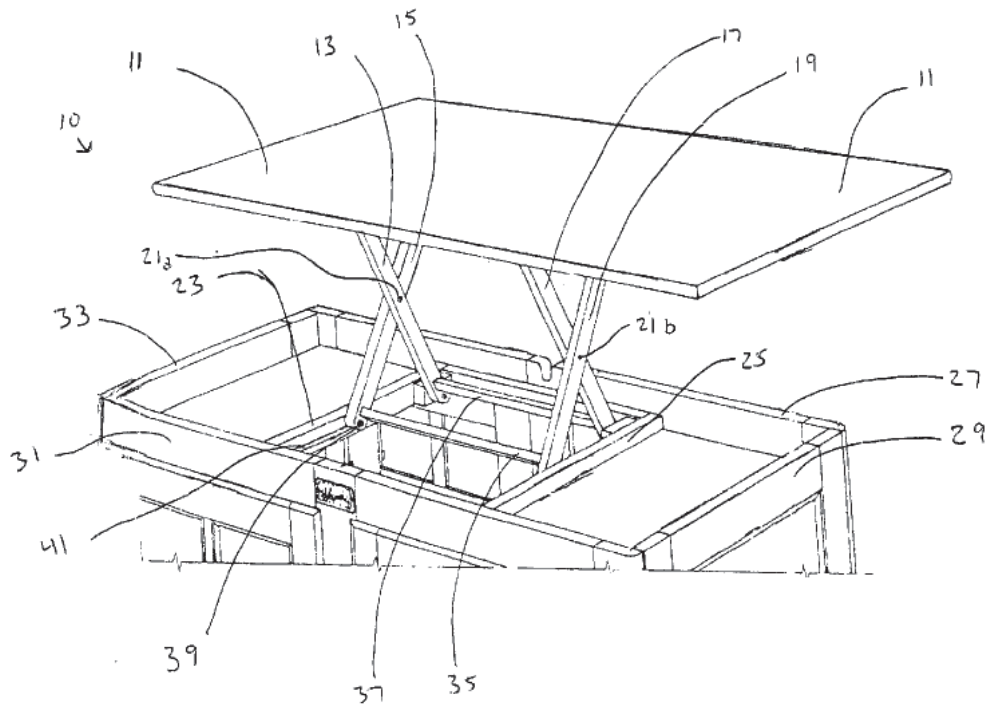

17

29. Many different office desktop scissor mechanisms have been on the market as early as 2014. The product below was listed on the Applied Ergonomics site on August 10, 2014 as evidenced by the referenced link below. This early desktop scissor product enabled the user to raise and lower their keyboard for sitting or standing.

¹⁷ US 20,040,040,480 Hwang



18

30. US 7,950,338 by Ole Falk Smed filed in 2008 show a very similar device.

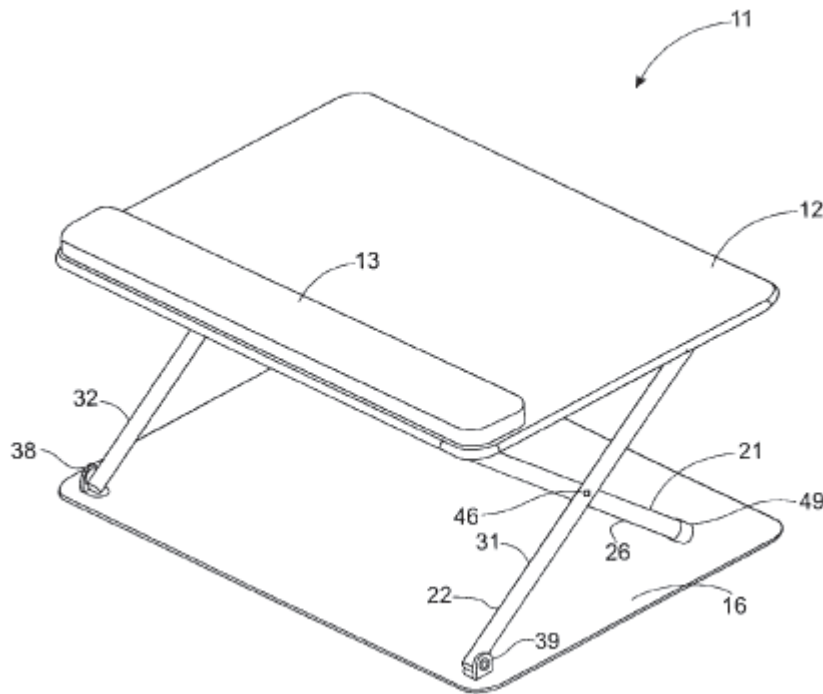

19

31. As shown above, the Smed device shows a platform element 13 on top of the scissor lift platform. This is an ordinary and expectable element of design or even use. A scissor lift

¹⁸ <<https://web.archive.org/web/20140810113449/http://www.appliedergonomics.com/articulating-keyboard-tray-mouse-systems/>> accessed Jan 2, 2025

¹⁹ US 7,950,338 Smed

platform is generally intended to lift something up to an elevated height. It would be useless if the scissor lift platform was just set at a particular height and didn't support anything on top of it.

32. US patent application 2014/0144352 by Christopher John Roberts (hereafter "Roberts") was filed in 2013 and shows another design for a scissor lift based office desktop system. As shown below, this system shows an ordinary computer screen and keyboard being supported at two different heights for ordinary office work use.

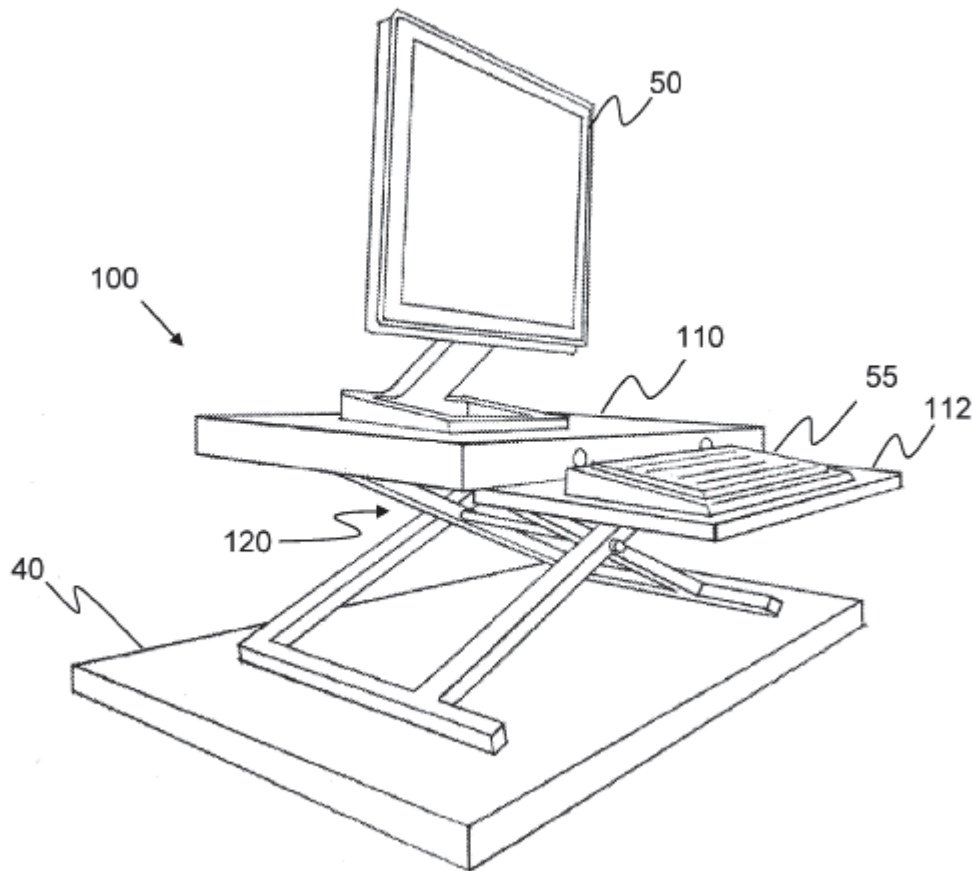

20

33. The scissor lift platform shown above, uses ordinary coil springs to assist in the lifting of the platform.²¹ An ordinary designer will understand that spring selection could use all manner of springs such as coil springs, gas springs, leaf springs, torsion springs, and the like. When

²⁰ US 20,140,144,352 Roberts

²¹ US 20,140,144,352 Roberts [0013]

choosing the type of spring, the use of a coil spring presents certain advantages over that of a gas spring as a traditional coil spring has a force that varies with extension more so than a typical gas spring. This allows the spring force to be more closely matched with the changing mechanical advantage of the scissor linkage itself. Combined with a locking mechanism (which Roberts also teaches²²) a scissor lift mechanism for ordinary office work is taught which has a lift-assist spring and which can be set at a variety of vertical positions.

XI. INVALIDITY CHARTS

34. I have performed an invalidity analysis on the Asserted Claims of the present matter. These charts demonstrate how the Asserted Claims of the Asserted Patent are invalid for being obvious in view of the prior art. It is my opinion that the Asserted Patent should never have been allowed to issue because it does not contribute anything inventive to the field of desk and platform design. The invalidity charts are attached to my declaration as Exhibits 1007-1010.

XII. SECONDARY CONSIDERATIONS OF NONOBVIOUSNESS

35. I understand that secondary considerations of non-obviousness are relevant to the validity analysis of a challenged patent. I understand that secondary considerations may include things such as long-felt but unfulfilled need for the claimed invention, failure of others where the claimed invention succeeds, commercial success of the claimed invention, praise of the claimed invention by others in the field, unexpected results achieved by the invention, the taking of licenses under the patent by others, expressions of surprise by experts and those skilled in the art of the making of the claimed invention, and whether the patentee proceeded contrary to the conventional wisdom of the prior art. I further understand that a claim of secondary

²² US 20,140,144,352 Roberts [0024]

considerations of non-obviousness must be substantiated by a nexus to the specific allegedly inventive features.

36. At the present time, I am unaware of any secondary considerations of non-obviousness having been asserted. Should such assertions be made in the future, I reserve the right to review, respond, and as appropriate, rebut such assertions. As discussed previously, it is my opinion that the claimed invention is not an invention at all. Rather, it is the ordinary combination of well-known design elements in well-known ways, producing highly predictable and non-surprising results. Scissor lift mechanisms that use a piston and cylinder style actuator, such as a gas spring, are well known and replete throughout the prior art. I am unaware of any failed attempts by others to produce an apparatus similar to the alleged invention. To the extent that the claimed invention took more than a single prototype to develop, this would reflect poorly on the experience and knowledge of the designer more than it would on the technical challenge (or lack thereof) presented by the alleged invention.

XIII. CONCLUSION

37. For at least the reasons set forth herein, it is my opinion that US 11,849,843 is invalid as it is obvious in view of the prior art.

38. I hereby declare under penalty of perjury that all statements made herein of my own knowledge are true and that all statements made on information and belief are believed to be true. I understand that willfully false statements and the like are punishable by fine, imprisonment, or both under 18 U.S.C § 1001.

Executed on January 14, 2025



By: Nathan Macdonald, P.E., CSP