



US012193569B1

(12) **United States Patent**  
**Poniatowski**

(10) **Patent No.:** **US 12,193,569 B1**  
(45) **Date of Patent:** **\*Jan. 14, 2025**

(54) **DESKTOP WORKSPACE THAT ADJUSTS VERTICALLY**

2021/0364; A47B 2021/0335; A47B 3/00;  
A47B 61/00; A47B 3/02; A47B 3/0809;  
A47B 3/0815; A47B 2003/025

(71) Applicant: **Office Kick, Inc.**, Boulder, CO (US)

(Continued)

(72) Inventor: **Nathan Mark Poniatowski**, St. Petersburg, FL (US)

(56) **References Cited**

U.S. PATENT DOCUMENTS

(73) Assignee: **Office Kick, Inc.**, Boulder, CO (US)

200,057 A 2/1878 Hart  
317,468 A 5/1885 Morstatt

(\*) Notice: Subject to any disclaimer, the term of this patent is extended or adjusted under 35 U.S.C. 154(b) by 0 days.

(Continued)

This patent is subject to a terminal disclaimer.

FOREIGN PATENT DOCUMENTS

AU 5691386 A 11/1986  
AU 580874 B2 2/1989

(Continued)

(21) Appl. No.: **18/648,253**

OTHER PUBLICATIONS

(22) Filed: **Apr. 26, 2024**

"Easylift Gas Springs: Technical Information," Web page, Aug. 24, 2008, retrieved from Internet Archive Wayback Machine on Aug. 29, 2022.

(Continued)

**Related U.S. Application Data**

(60) Continuation of application No. 18/481,082, filed on Oct. 4, 2023, which is a continuation of application (Continued)

*Primary Examiner* — Janet M Wilkens  
(74) *Attorney, Agent, or Firm* — Lund IP, PLLC

(51) **Int. Cl.**  
*A47B 9/16* (2006.01)  
*A47B 21/02* (2006.01)

(Continued)

(57) **ABSTRACT**  
A desktop workspace that adjusts vertically includes a work surface platform, a base configured to sit on an existing platform, such as a desk, a height adjustable mechanism including at least one set of arms that connect at a pivot point(s) creating a scissoring motion to raise and lower the said work surface platform to various heights. A locking and unlocking mechanism may connect to the height adjustable mechanism. In some cases, the apparatus includes an adjustable mechanism to support items such as a keyboard. In some cases, the apparatus includes elements to raise items such as a monitor to an additional height.

(52) **U.S. Cl.**  
CPC ..... *A47B 9/16* (2013.01); *A47B 21/02* (2013.01); *A47B 21/0314* (2013.01); *A47B 21/04* (2013.01); *A47B 2021/0335* (2013.01)

(58) **Field of Classification Search**  
CPC ..... A47B 1/03; A47B 21/0314; A47B 21/00; A47B 21/02; A47B 21/03; A47B 21/04; A47B 9/16; A47B 2021/0321; A47B

**18 Claims, 28 Drawing Sheets**

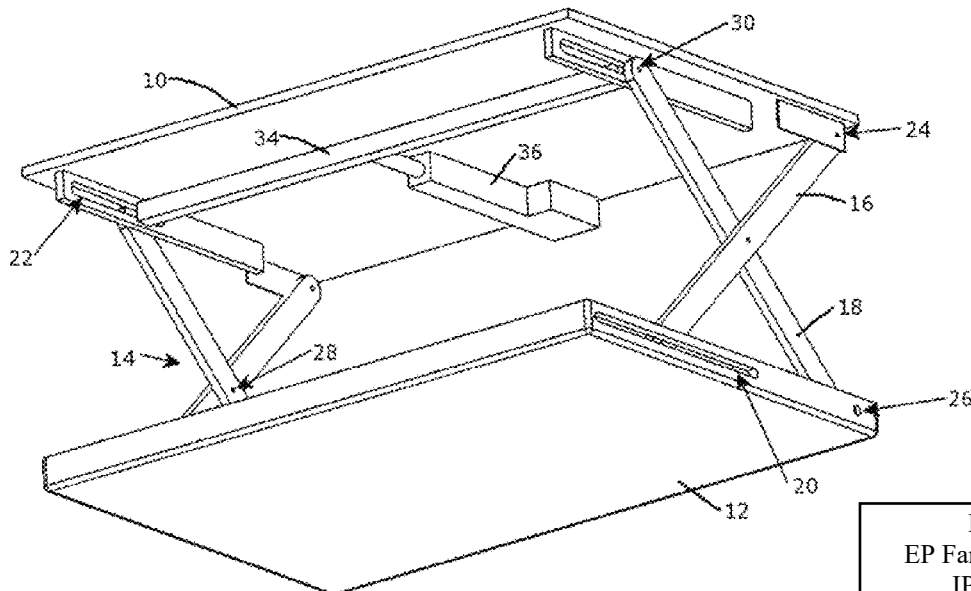

Exhibit 2004  
EP Family v Office Kick  
IPR2025-00471

**Related U.S. Application Data**

No. 17/985,137, filed on Nov. 10, 2022, now Pat. No. 11,910,926, which is a continuation of application No. 17/493,812, filed on Oct. 4, 2021, now Pat. No. 11,944,196, which is a continuation of application No. 16/785,647, filed on Feb. 9, 2020, now Pat. No. 11,134,773, which is a continuation of application No. 16/372,334, filed on Apr. 1, 2019, now Pat. No. 10,575,630, which is a division of application No. 15/628,558, filed on Jun. 20, 2017, now Pat. No. 10,244,861, which is a division of application No. 15/004,926, filed on Jan. 23, 2016, now abandoned.

(60) Provisional application No. 62/107,380, filed on Jan. 24, 2015.

(51) **Int. Cl.**

*A47B 21/03* (2006.01)  
*A47B 21/04* (2006.01)

(58) **Field of Classification Search**

USPC ..... 312/208.1, 223.3; 248/421, 562, 588, 248/585, 431, 432, 439; 108/147, 144.11, 108/145, 93, 96, 116–118.12, 43.138, 108/50.1, 5.2, 28

See application file for complete search history.

(56) **References Cited**

U.S. PATENT DOCUMENTS

606,845 A 7/1898 Simmons  
 835,247 A 11/1906 Morgan  
 1,217,772 A 2/1917 Kade  
 1,318,564 A 10/1919 Jenkins  
 2,225,243 A 12/1940 Zottel  
 2,260,695 A 10/1941 Clyde  
 2,692,807 A 10/1954 Fred  
 2,843,418 A 7/1958 Gray  
 2,916,340 A 12/1959 Jackson  
 2,937,003 A 5/1960 Croll  
 3,092,918 A 6/1963 Haeussermann et al.  
 3,110,476 A 11/1963 Farris  
 3,152,833 A 10/1964 Creveling et al.  
 3,282,566 A 11/1966 Clarke  
 3,295,800 A 1/1967 Karl-Erik et al.  
 3,404,791 A 10/1968 Roy  
 3,444,830 A 5/1969 Doetsch  
 3,727,245 A 4/1973 Gerth  
 3,823,915 A 7/1974 Koehler  
 3,826,457 A 7/1974 De  
 4,072,288 A 2/1978 Wirges et al.  
 4,097,941 A 7/1978 Merkel  
 4,221,280 A 9/1980 Richards  
 4,249,749 A 2/1981 Collier  
 4,382,573 A 5/1983 Aondetto  
 4,403,680 A 9/1983 Hillesheimer  
 4,433,759 A 2/1984 Ichinose  
 4,448,386 A 5/1984 Moorhouse et al.  
 4,449,262 A 5/1984 Jahsman et al.  
 4,534,544 A 8/1985 Heide  
 4,549,720 A 10/1985 Bergenwall  
 4,558,648 A 12/1985 Franklin et al.  
 4,558,847 A 12/1985 Coates  
 4,574,785 A 3/1986 Yamamoto  
 4,577,821 A 3/1986 Edmo et al.  
 4,611,823 A 9/1986 Haas  
 4,625,657 A 12/1986 Little et al.  
 4,640,488 A 2/1987 Sakamoto  
 4,659,052 A 4/1987 Nagata  
 4,702,454 A 10/1987 Izumida  
 4,709,972 A 12/1987 LaBudde et al.  
 4,717,112 A 1/1988 Pirkle  
 4,741,512 A 5/1988 Elkuch et al.

4,753,419 A 6/1988 Johansson  
 4,826,123 A 5/1989 Hannah et al.  
 4,843,978 A 7/1989 Schmidt et al.  
 D302,893 S 8/1989 Wakefield  
 4,899,987 A 2/1990 Craig  
 4,909,159 A 3/1990 Gonsoulin  
 D308,537 S 6/1990 Clark  
 4,941,641 A 7/1990 Granzow et al.  
 4,967,672 A 11/1990 Leather  
 4,995,130 A 2/1991 Hahn et al.  
 5,037,163 A 8/1991 Hatcher  
 5,048,784 A 9/1991 Schwartz et al.  
 5,074,000 A 12/1991 Soltani et al.  
 5,211,367 A 5/1993 Musculus  
 5,251,864 A 10/1993 Itou  
 5,257,767 A 11/1993 McConnell  
 5,294,087 A 3/1994 Drabczyk et al.  
 5,400,720 A 3/1995 Stevens  
 5,460,460 A 10/1995 Alexander  
 5,580,027 A 12/1996 Brodersen  
 5,588,377 A 12/1996 Fahmian  
 5,588,727 A 12/1996 D'Agaro et al.  
 5,626,323 A 5/1997 Lechman et al.  
 5,632,209 A 5/1997 Sakakibara  
 5,694,864 A 12/1997 Langewellpott  
 5,695,173 A 12/1997 Ochoa et al.  
 5,722,513 A 3/1998 Rowan et al.  
 5,729,430 A 3/1998 Johnson  
 5,765,797 A 6/1998 Greene et al.  
 5,823,487 A 10/1998 Kirchhoff et al.  
 5,829,948 A 11/1998 Becklund  
 5,836,562 A 11/1998 Danzyger et al.  
 5,895,020 A 4/1999 Danzyger et al.  
 5,926,876 A 7/1999 Haigh et al.  
 5,957,426 A 9/1999 Brodersen  
 6,076,785 A 6/2000 Oddsen, Jr.  
 6,098,961 A 8/2000 Gionet  
 6,135,546 A 10/2000 Demtchouk  
 6,148,739 A 11/2000 Martin  
 6,176,456 B1 1/2001 Wisniewski  
 6,179,261 B1 1/2001 Lin  
 6,220,558 B1 4/2001 Broder et al.  
 6,269,753 B1 8/2001 Roddan  
 6,273,382 B1 8/2001 Pemberton  
 6,381,335 B2 4/2002 Juszkiewicz et al.  
 6,488,248 B1 12/2002 Watt et al.  
 6,516,478 B2 2/2003 Cook et al.  
 6,533,229 B1 3/2003 Hung  
 6,533,479 B2 3/2003 Kochanski  
 6,550,740 B1 4/2003 Burer  
 6,672,430 B2 1/2004 Boucher et al.  
 6,701,853 B1 3/2004 Hwang  
 6,702,372 B2 3/2004 Tholkes et al.  
 6,722,618 B1 4/2004 Wu  
 6,742,768 B2 6/2004 Alba  
 6,792,876 B2 9/2004 Lin  
 6,857,493 B2 2/2005 Shupp et al.  
 6,938,866 B2 9/2005 Kirchhoff  
 7,048,236 B2 5/2006 Benden et al.  
 7,188,813 B2 3/2007 Kollar  
 7,204,193 B2 4/2007 Scherrer et al.  
 7,207,629 B2 4/2007 Goetz et al.  
 7,246,784 B1 7/2007 Lopez  
 7,568,675 B2 8/2009 Catton  
 7,575,205 B2 8/2009 Kirchhoff  
 7,677,518 B2 3/2010 Chouinard et al.  
 D622,350 S 8/2010 Gramegna et al.  
 7,793,597 B2 9/2010 Bart et al.  
 7,841,570 B2 11/2010 Mileos et al.  
 7,845,665 B2 12/2010 Borisoff  
 7,946,551 B1 5/2011 Cvek  
 7,950,338 B2 5/2011 Smed  
 7,988,232 B2 8/2011 Weber et al.  
 8,015,638 B2 9/2011 Shimada et al.  
 8,132,518 B2 3/2012 Kim et al.  
 8,303,062 B2 11/2012 Zanelli  
 8,469,152 B2 6/2013 Olsen et al.  
 8,490,933 B2 7/2013 Papic et al.  
 8,544,391 B2 10/2013 Knox et al.

(56)		References Cited			
		U.S. PATENT DOCUMENTS			
8,671,853	B2	3/2014	Flaherty	11,864,654	B1
8,684,339	B2	4/2014	Deml et al.	11,910,926	B1
8,800,976	B2	8/2014	Bethina et al.	11,925,264	B1
8,931,750	B2	1/2015	Kohl et al.	11,944,196	B1
8,950,343	B2	2/2015	Huang	11,950,699	B1
9,049,923	B1	6/2015	Delagey et al.	11,980,289	B1
9,055,810	B2	6/2015	Flaherty	12,082,695	B1
9,113,703	B2	8/2015	Flaherty	12,082,696	B1
9,133,974	B2	9/2015	Tholkes et al.	12,102,229	B1
9,133,976	B2	9/2015	Lin et al.	12,121,149	B1
9,232,855	B2	1/2016	Ergun et al.	2003/0042380	A1
9,326,598	B1	5/2016	West et al.	2003/0213415	A1
9,440,559	B2	9/2016	Gundall et al.	2004/0035332	A1
9,480,332	B2	11/2016	Han	2004/0040480	A1
9,504,316	B1	11/2016	Streicher et al.	2005/0029849	A1
9,554,644	B2	1/2017	Flaherty et al.	2005/0120922	A1
9,668,572	B2	6/2017	Ergun et al.	2007/0001077	A1
9,681,746	B1	6/2017	Chen	2007/0080564	A1
9,809,136	B2	11/2017	Haller et al.	2007/0266912	A1
9,815,672	B2	11/2017	Baudermann	2007/0295882	A1
9,854,904	B2	1/2018	Getz	2008/0000393	A1
9,955,780	B2	5/2018	Koch	2009/0090832	A1
9,961,991	B1	5/2018	Chen	2009/0145336	A1
9,981,571	B2	5/2018	Garing	2009/0146389	A1
9,993,068	B2	6/2018	Lin et al.	2009/0200437	A1
10,018,298	B2	7/2018	Goldish et al.	2010/0242174	A1
10,023,355	B2	7/2018	Taylor et al.	2010/0257671	A1
D830,739	S	10/2018	Min	2011/0001033	A1
10,114,352	B2	10/2018	Matlin	2011/0024958	A1
D832,623	S	11/2018	Flaherty et al.	2011/0024958	A1
10,123,613	B2	11/2018	Hall et al.	2012/0060291	A1
10,159,336	B2	12/2018	Liao et al.	2012/0097822	A1
D841,014	S	2/2019	Laudadio et al.	2012/0188302	A1
D845,037	S	4/2019	Min	2013/0145972	A1
D845,678	S	4/2019	Laudadio et al.	2013/0193392	A1
10,244,861	B1	4/2019	Poniatowski	2013/0199420	A1
10,258,148	B1	4/2019	Donner et al.	2013/0340655	A1
10,258,149	B2	4/2019	Zhong	2014/0041554	A1
10,264,877	B2	4/2019	Hu et al.	2014/0144352	A1
10,306,977	B2	6/2019	Wong	2014/0158026	A1
D854,775	S	7/2019	Chang et al.	2014/0248114	A1
10,405,647	B2	9/2019	Laudadio et al.	2014/0339747	A1
10,413,055	B2	9/2019	Laudadio et al.	2014/0360411	A1
D862,936	S	10/2019	Laudadio et al.	2015/0028787	A1
10,485,336	B1	11/2019	Laudadio et al.	2015/0216296	A1
D870,490	S	12/2019	Hu	2015/0231992	A1
10,499,730	B2	12/2019	Kim et al.	2015/0232005	A1
10,517,390	B2	12/2019	Xiang et al.	2015/0274038	A1
10,524,565	B2	1/2020	Ergun et al.	2015/0289641	A1
10,542,817	B2	1/2020	Swartz et al.	2015/0368082	A1
10,544,019	B2	1/2020	Kochie et al.	2015/0375896	A1
10,568,416	B1	2/2020	Poniatowski	2016/0051042	A1
10,575,630	B1	3/2020	Poniatowski	2016/0060084	A1
D901,959	S	11/2020	Chang	2016/0106205	A1
10,849,424	B2	12/2020	Laudadio et al.	2016/0170402	A1
10,869,549	B2	12/2020	Xiang et al.	2016/0249737	A1
10,893,748	B1	1/2021	Poniatowski	2016/0258573	A1
11,058,217	B2	7/2021	Laudadio et al.	2016/0260019	A1
11,083,282	B1	8/2021	Liu	2016/0260019	A1
11,134,773	B1	10/2021	Poniatowski	2016/0309889	A1
11,134,774	B1	10/2021	Poniatowski	2016/0338486	A1
11,140,977	B1	10/2021	Poniatowski	2016/0353880	A1
11,147,366	B1	10/2021	Poniatowski	2017/0071332	A1
11,160,367	B1	11/2021	Poniatowski	2017/0174486	A1
11,219,307	B2	1/2022	Laudadio et al.	2017/0196351	A1
11,388,989	B1	7/2022	Poniatowski	2017/0354245	A1
11,388,991	B1	7/2022	Poniatowski	2017/0360192	A1
11,395,544	B1	7/2022	Poniatowski	2018/0008037	A1
11,464,325	B1	10/2022	Poniatowski	2018/0055214	A1
11,470,959	B1	10/2022	Poniatowski	2018/0103752	A1
11,717,080	B2	8/2023	Laudadio et al.	2018/0125227	A1
11,771,218	B2	10/2023	Laudadio et al.	2018/0160799	A1
11,800,927	B1	10/2023	Poniatowski	2018/0177289	A1
11,849,843	B1	12/2023	Poniatowski	2018/0213929	A1
11,857,073	B1	1/2024	Poniatowski	2018/0255919	A1
				2018/0279770	A1
				2018/0360208	A1
				2019/0110588	A1
				2019/0183239	A1
				2019/0269237	A1
				1/2024	Poniatowski
				2/2024	Poniatowski
				3/2024	Poniatowski
				4/2024	Poniatowski
				4/2024	Poniatowski
				5/2024	Poniatowski
				9/2024	Poniatowski
				9/2024	Poniatowski
				10/2024	Poniatowski
				10/2024	Poniatowski
				3/2003	Hagglund et al.
				11/2003	Ross et al.
				2/2004	Lin
				3/2004	Hwang
				2/2005	Goetz et al.
				6/2005	Brooks
				1/2007	Kirchhoff
				4/2007	Chen
				11/2007	Swain
				12/2007	Catton
				1/2008	Wilson et al.
				4/2009	Mileos et al.
				6/2009	Kenny
				6/2009	Borisoff
				8/2009	Smed
				9/2010	Morrison et al.
				10/2010	Shimada et al.
				1/2011	Kohl et al.
				2/2011	Deml et al.
				3/2012	Gamman et al.
				4/2012	Hammarstiö
				7/2012	Zanelli
				6/2013	Knox et al.
				8/2013	McGinn
				8/2013	Hjelm
				12/2013	Flaherty
				2/2014	Huang
				5/2014	Roberts
				6/2014	Flaherty
				9/2014	Sawyer
				11/2014	Bethina et al.
				12/2014	Hatter
				1/2015	Sekine et al.
				8/2015	Mitchell
				8/2015	Gundall et al.
				8/2015	Haller et al.
				10/2015	Garing
				10/2015	Ergun et al.
				12/2015	Davis et al.
				12/2015	Taylor et al.
				2/2016	Koch
				3/2016	Baudermann
				4/2016	Hall et al.
				6/2016	Lindström
				9/2016	Han
				9/2016	Goldish et al.
				9/2016	Ruiz et al.
				10/2016	Lin et al.
				11/2016	Martin
				12/2016	Sigal et al.
				3/2017	Herring et al.
				6/2017	Kochie et al.
				7/2017	Failing
				12/2017	Martin et al.
				12/2017	Hu
				1/2018	Laudadio
				3/2018	Kim et al.
				4/2018	Zhong
				5/2018	Xiang et al.
				6/2018	Westergård et al.
				6/2018	Chen
				8/2018	Ergun et al.
				9/2018	Swartz et al.
				10/2018	Crowe et al.
				12/2018	Liao et al.
				4/2019	Wong
				6/2019	Semmelrath et al.
				9/2019	Zhu

(56)

References Cited

U.S. PATENT DOCUMENTS

2020/0029685 A1 1/2020 Du et al.  
 2020/0107633 A1 4/2020 Kang  
 2023/0329430 A1 10/2023 Laudadio et al.

FOREIGN PATENT DOCUMENTS

AU 2014216002 A1 3/2015  
 CA 2814945 C 4/2019  
 CN 1142343 A 2/1997  
 CN 2637251 Y 9/2004  
 CN 2781893 Y 5/2006  
 CN 201657970 U 12/2010  
 CN 102599728 A 7/2012  
 CN 202681005 U 1/2013  
 CN 202681013 U 1/2013  
 CN 202874336 U 4/2013  
 CN 101711220 B 11/2013  
 CN 203333240 U 12/2013  
 CN 103653780 A 3/2014  
 CN 203934825 U 11/2014  
 CN 204541230 U 8/2015  
 CN 105124920 A 12/2015  
 CN 204949970 U 1/2016  
 CN 104692286 B 4/2017  
 CN 104540707 B 5/2017  
 CN 107048694 A 8/2017  
 CN 107048695 A 8/2017  
 CN 107212587 A 9/2017  
 CN 107744256 A 3/2018  
 CN 107756350 A 3/2018  
 CN 107912868 A 4/2018  
 CN 207186305 U 4/2018  
 CN 109008216 A 12/2018  
 CN 208403596 U 1/2019  
 CN 110840072 A 2/2020  
 CN 108024625 B 8/2021  
 DE 2851555 A1 6/1980  
 DE 8606822 U1 8/1991  
 DE 9302967 U1 4/1993  
 DE 4424564 A1 1/1996  
 DE 29515642 U1 1/1996  
 DE 69111809 T2 4/1996  
 DE 19526596 A1 12/2004  
 DE 102013008020 A1 11/2014  
 DE 202016101126 U1 6/2016  
 EP 0342779 B1 5/1993  
 EP 0531385 B1 8/1995  
 EP 0448340 B1 2/1996  
 EP 0613852 B1 11/1997  
 EP 2745733 A1 6/2014

EP 3092918 A1 11/2016  
 FR 2252835 A1 6/1975  
 FR 2637165 A1 4/1990  
 FR 2894794 A1 6/2007  
 FR 3028735 A1 5/2016  
 JP 2012030022 A 2/2012  
 JP 5861051 B2 2/2016  
 JP 2017045506 A 3/2017  
 KR 100802663 B1 2/2008  
 KR 20140004886 U 9/2014  
 KR 200479292 Y1 1/2016  
 KR 20160074221 A 6/2016  
 KR 101635611 B1 7/2016  
 KR 101747132 B1 6/2017  
 KR 101969133 B1 8/2019  
 NL 1011051 C2 7/2000  
 NL 2000346 C2 5/2008  
 TW 1531523 B 5/2016  
 WO 8304168 A1 12/1983  
 WO 8606053 A1 10/1986  
 WO 1986006054 A1 10/1986  
 WO 1988005759 A1 8/1988  
 WO 1991011979 A1 8/1991  
 WO 1991017906 A1 11/1991  
 WO 2008002373 A2 1/2008  
 WO 2014027010 A1 2/2014  
 WO 2014180572 A1 11/2014  
 WO 2015160825 A2 10/2015  
 WO 2016129971 A1 8/2016  
 WO 2016187212 A1 11/2016  
 WO 2016200318 A1 12/2016  
 WO 2017045506 A1 3/2017  
 WO 2017053200 A1 3/2017  
 WO 2018093007 A1 5/2018  
 WO 2019001506 A1 1/2019  
 WO 2019001507 A1 1/2019

OTHER PUBLICATIONS

Adjustable Desk: Varidesk, <http://www.varidesk.com>, United States of America, Mar. 30, 2013.  
 Ergotron, <http://www.ergotron.com>, United States of America, Sep. 29, 2014.  
 Levine, James A. "Sitting down is Killing you! Heart disease, obesity, depression and crumbling bones—a terrifying new book by a top doctor reveals they are all linked to the hours we spend in chairs" Daily Mail Online, Jul. 26, 2014, 9 pages [online], [retrieved on Jun. 30, 2017]. Retrieved from the Internet at: <http://www.dailymail.co.uk/news/article-2706317>.  
 Lohr, Steve, Taking a Stand for Office Ergonomics, Dec. 1, 2012, New York Times, United States, retrieved from <http://www.nytimes.com/2012/12/02/business/stand-up-desks-gaining-favor-in-the-workplace.html> on Aug. 29, 2022.

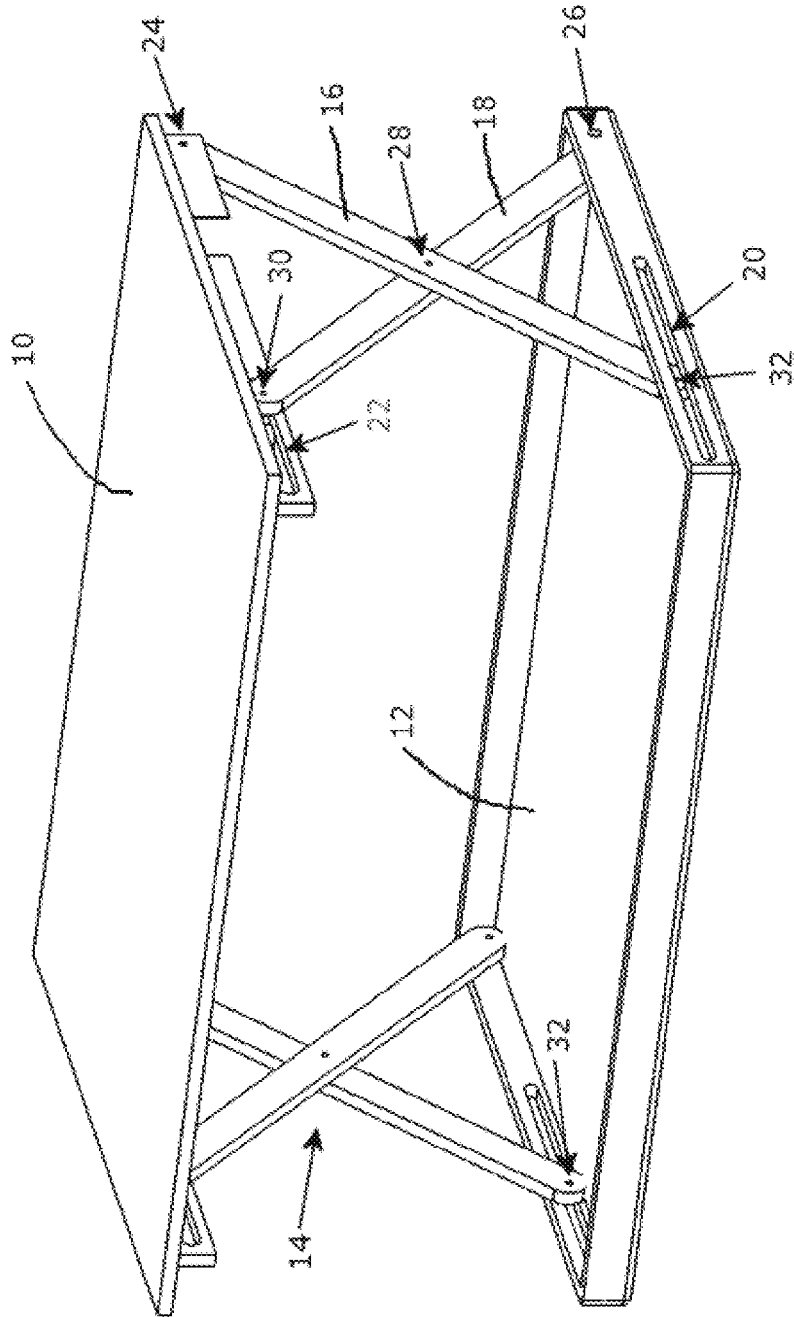

FIG. 1

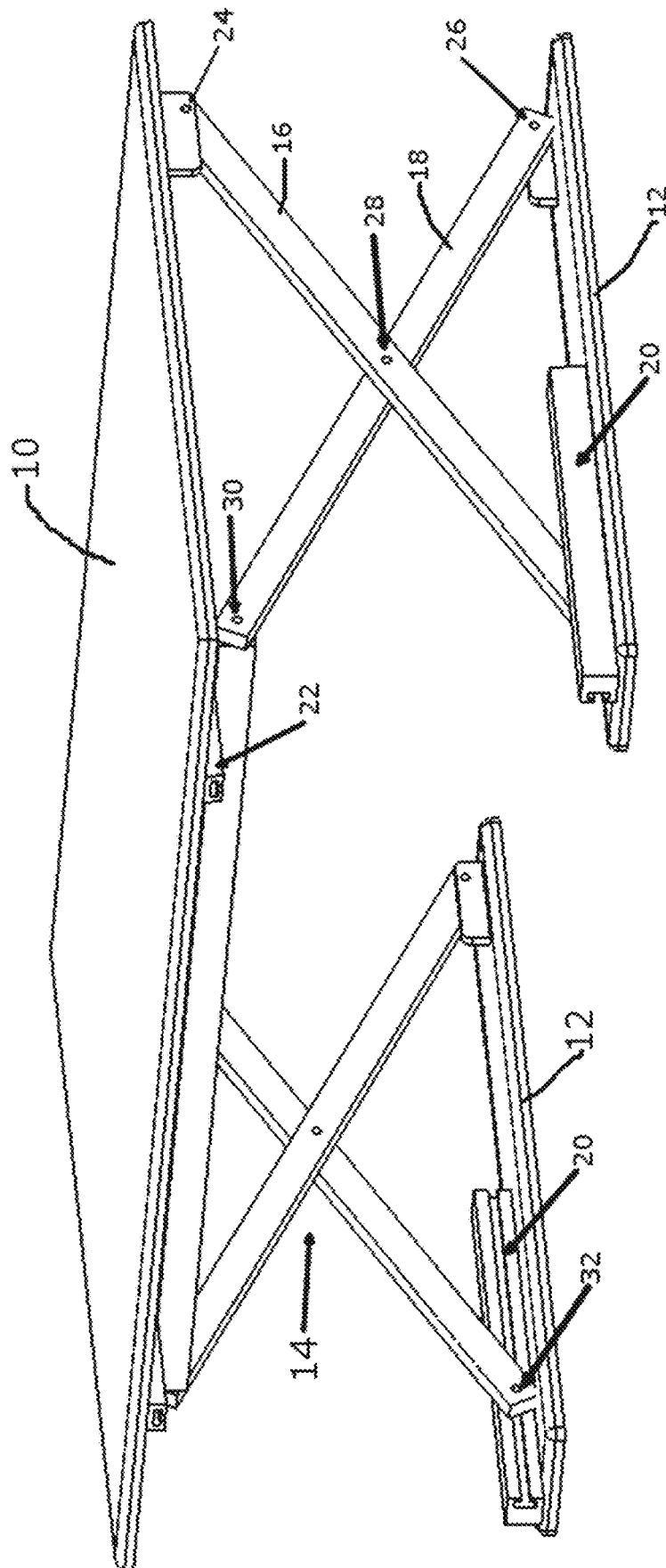

FIG. 1B

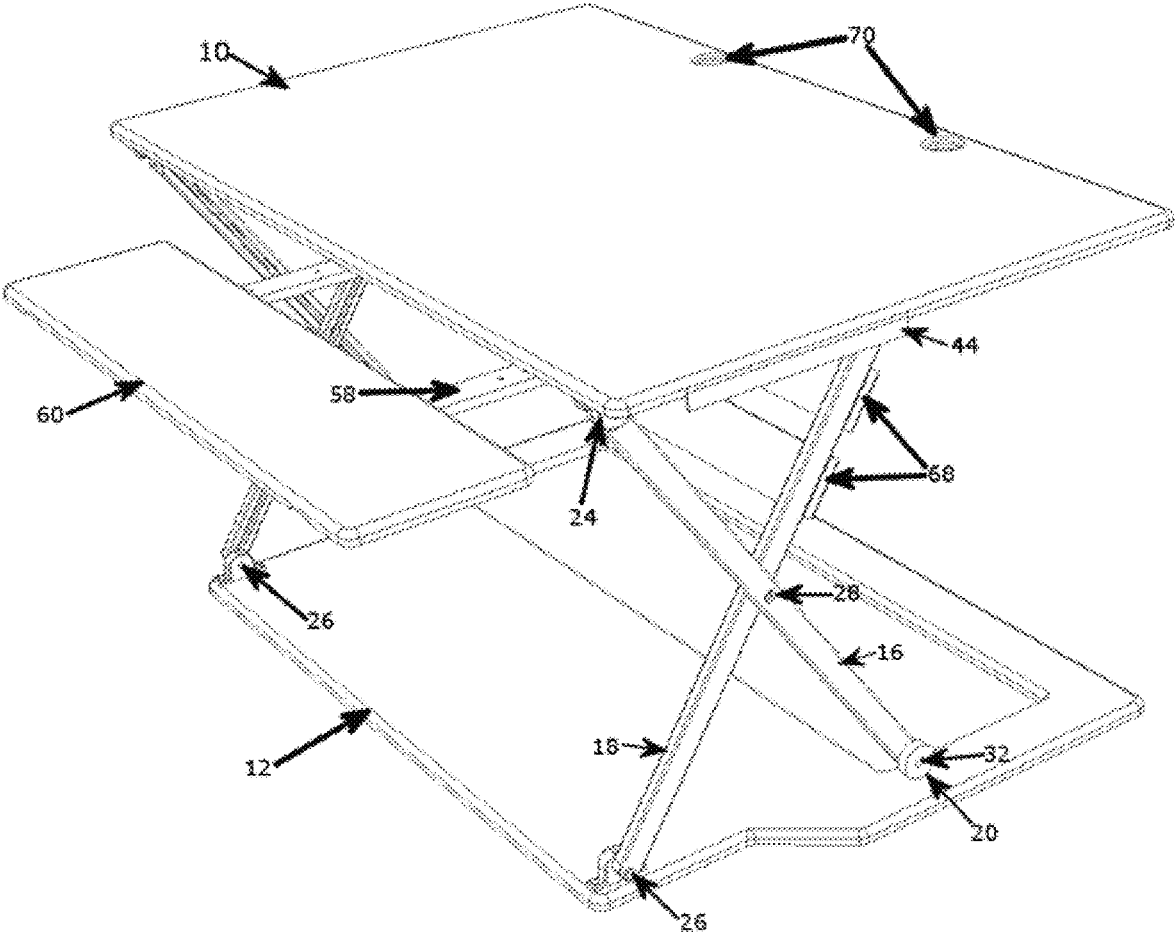
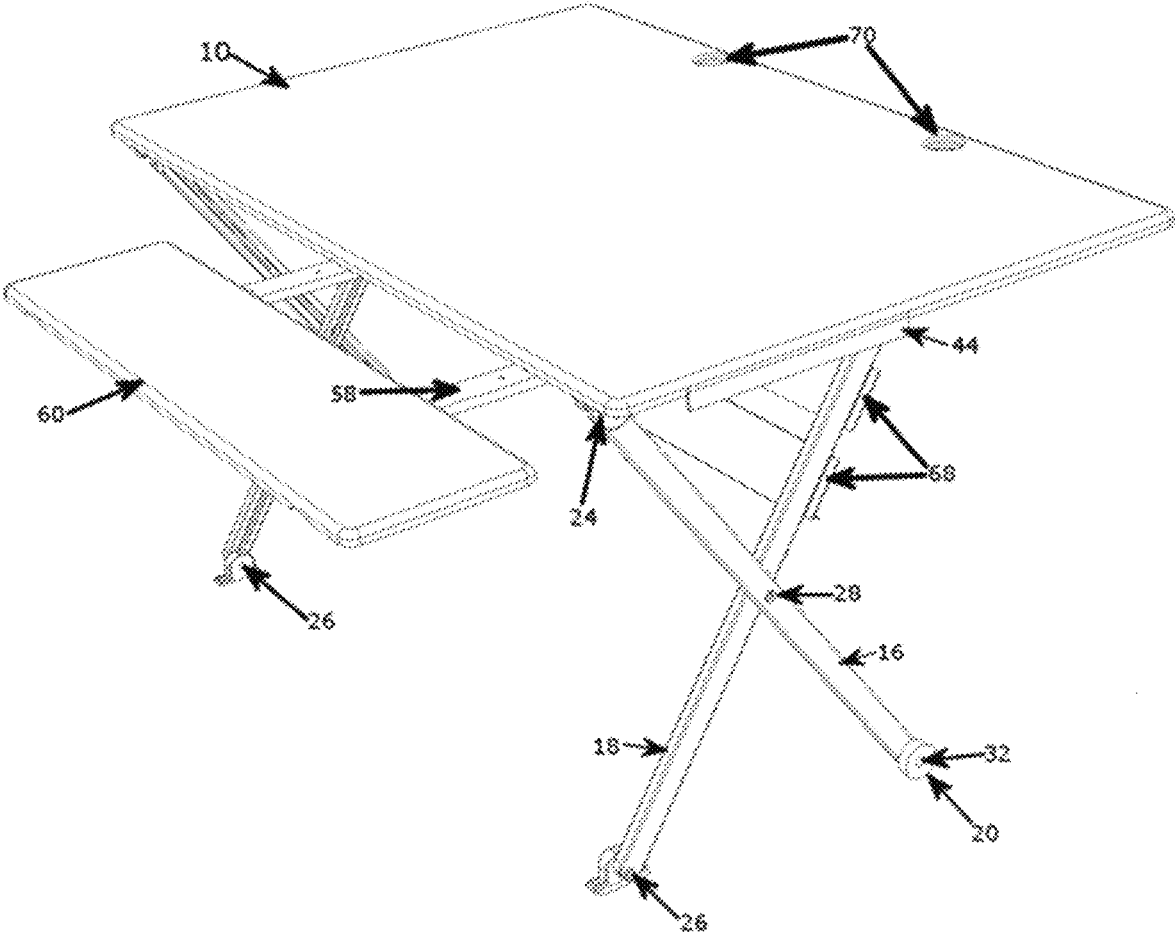

FIG. 1C



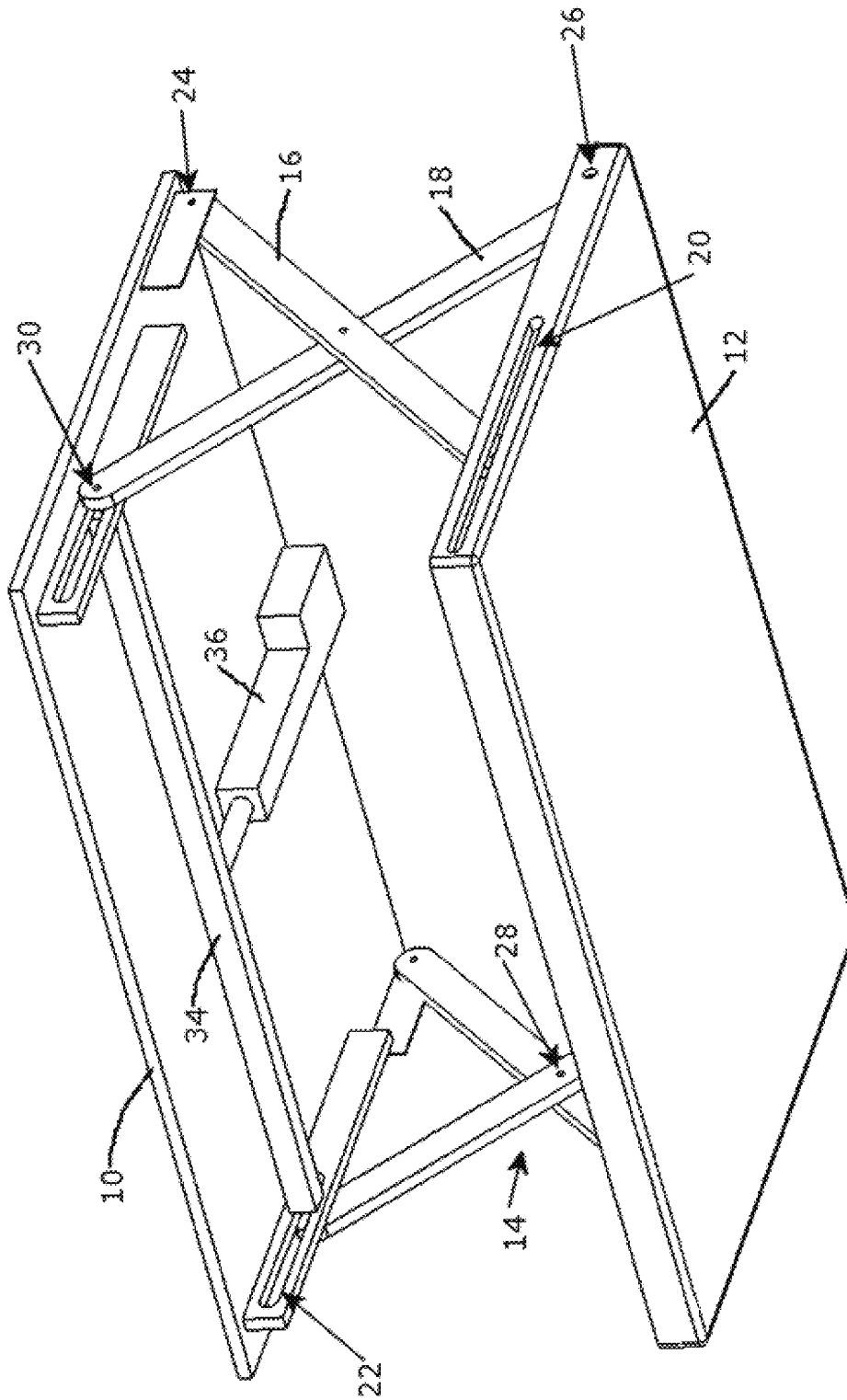

FIG. 2

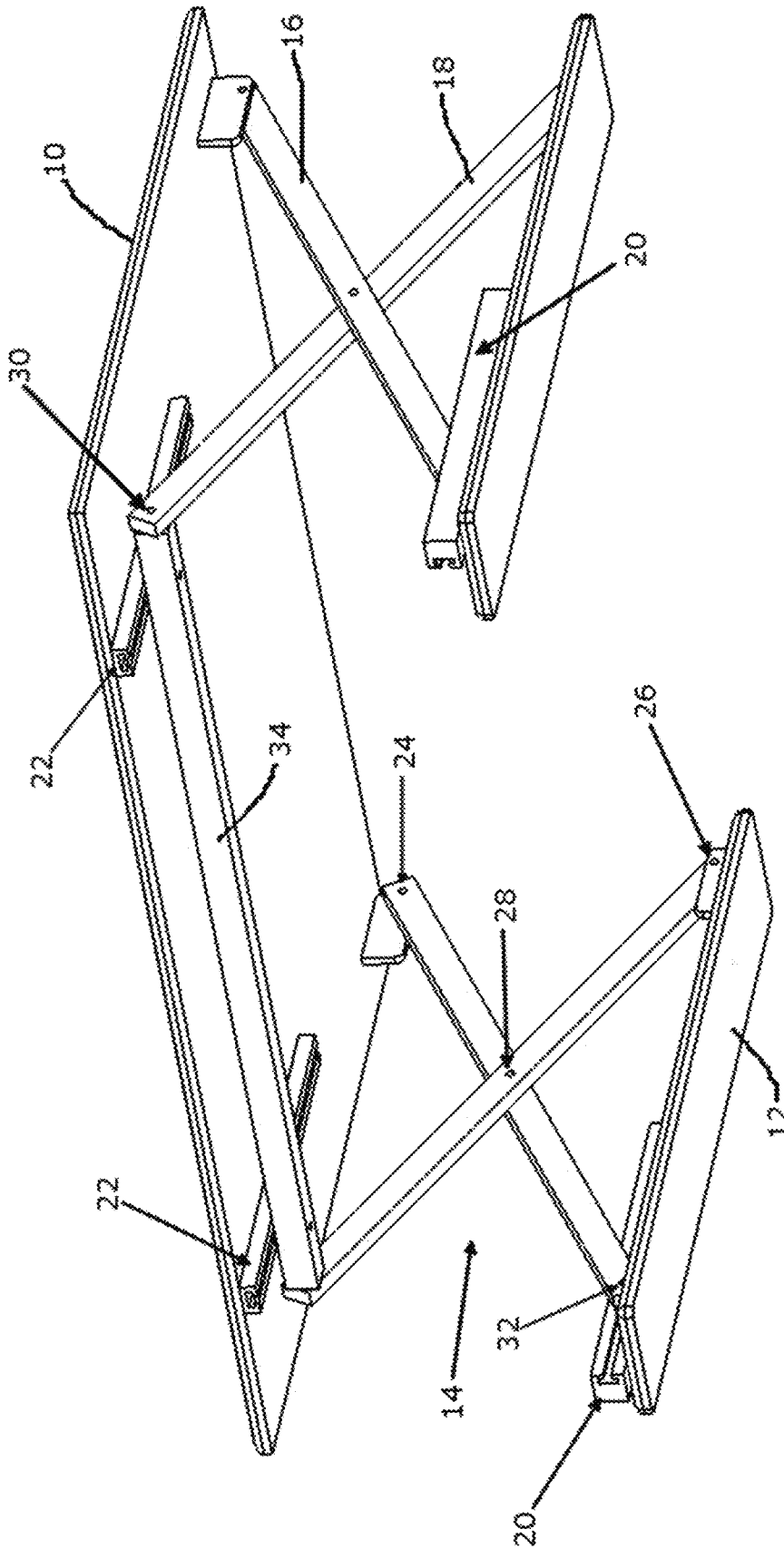

FIG. 2B

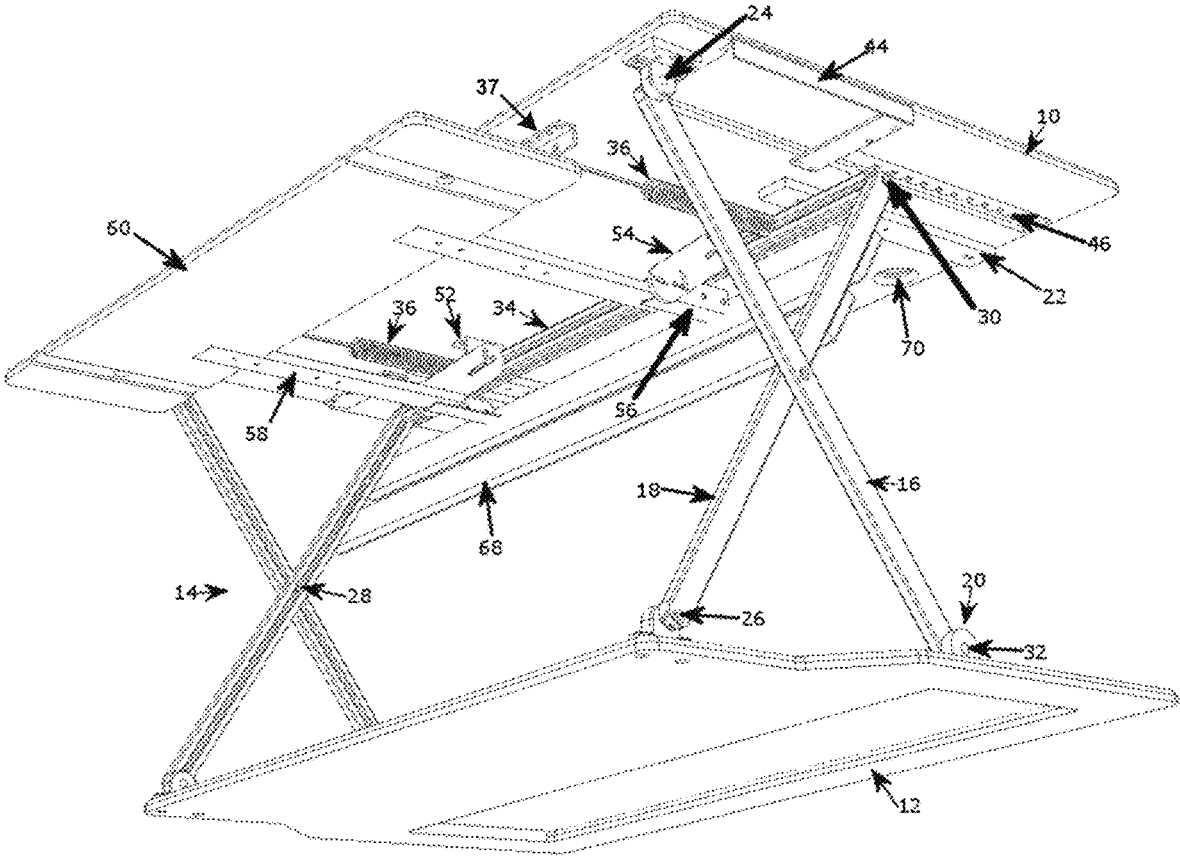

FIG. 2C

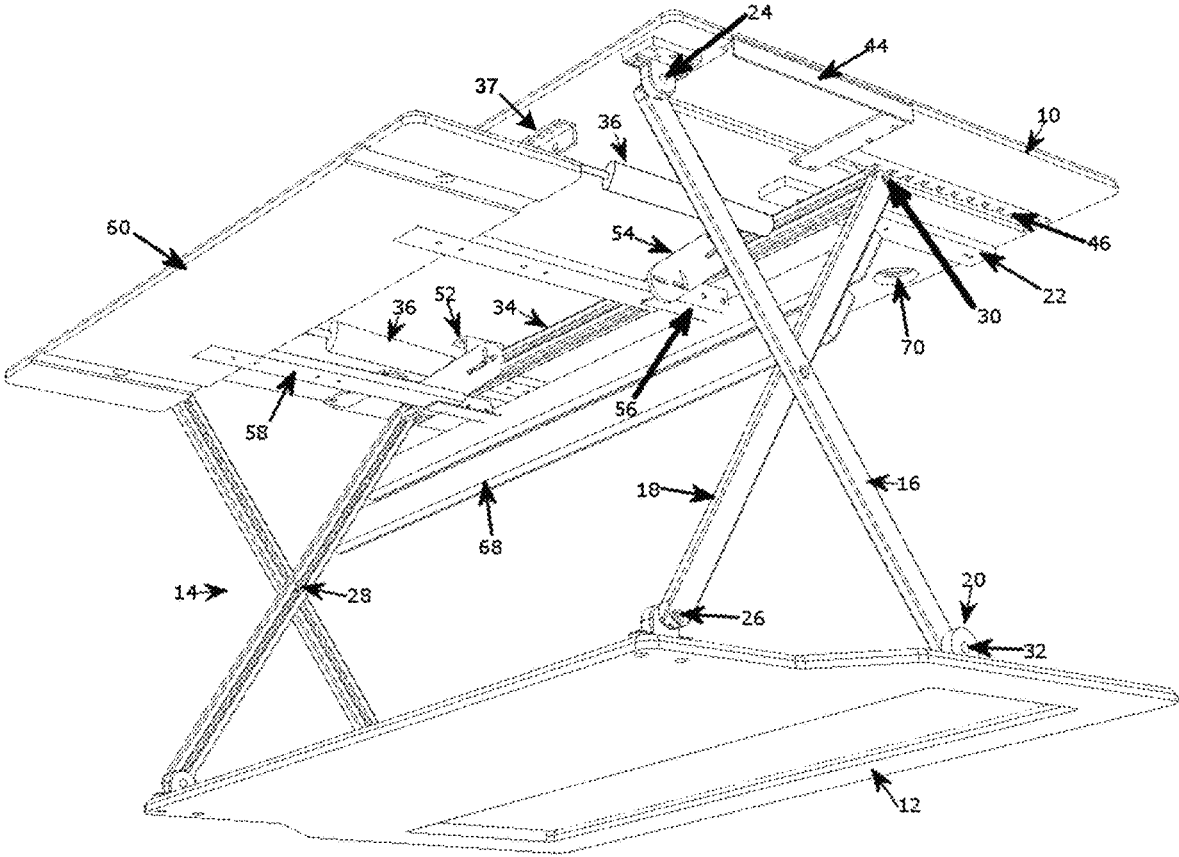

FIG. 2D

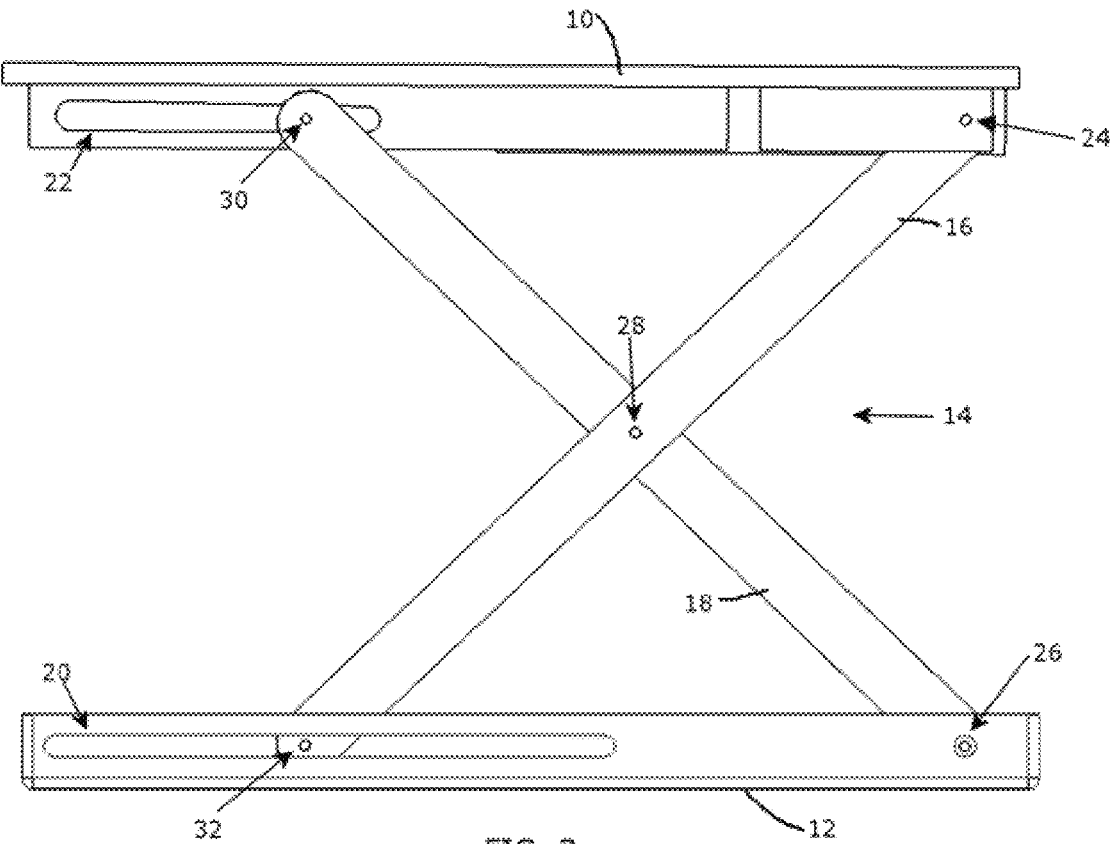

FIG. 3

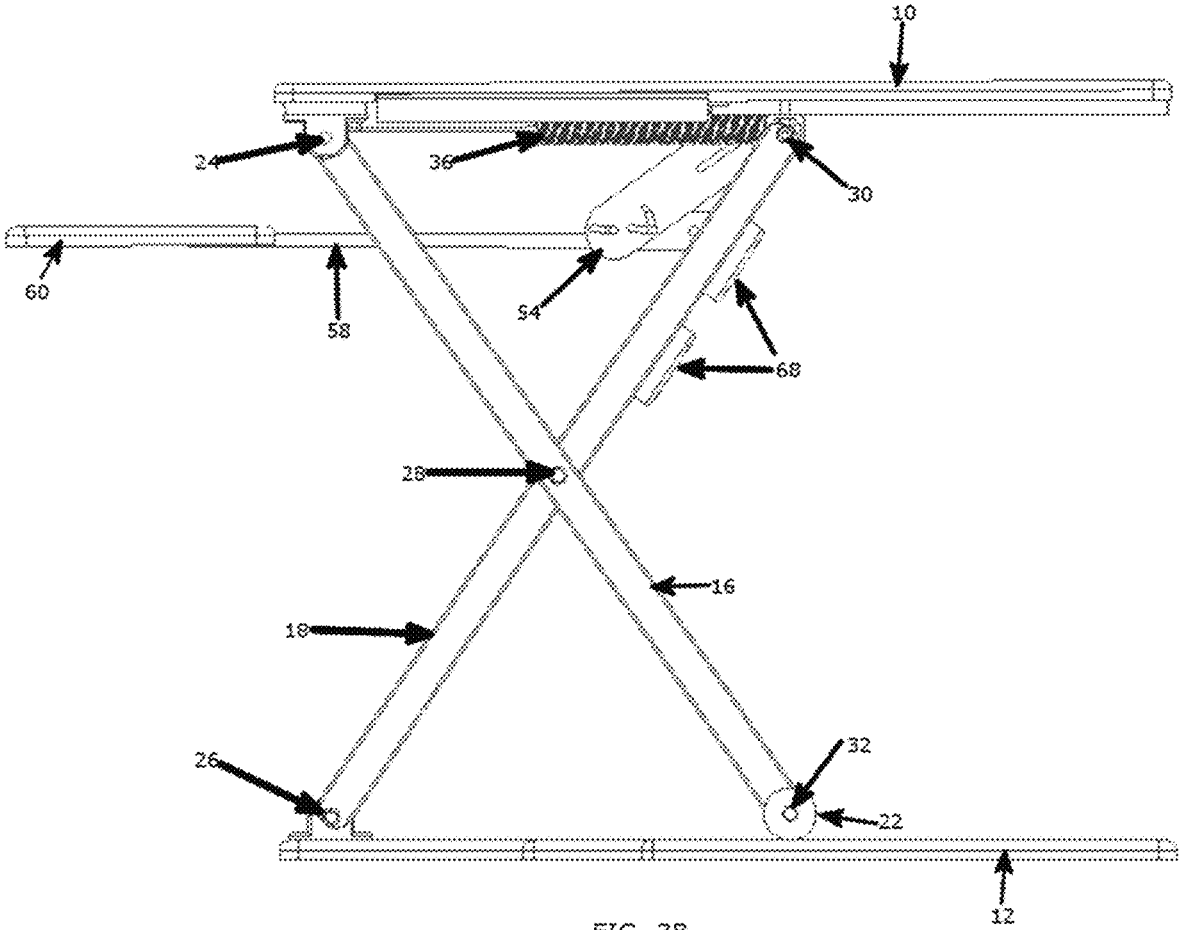

FIG. 3B

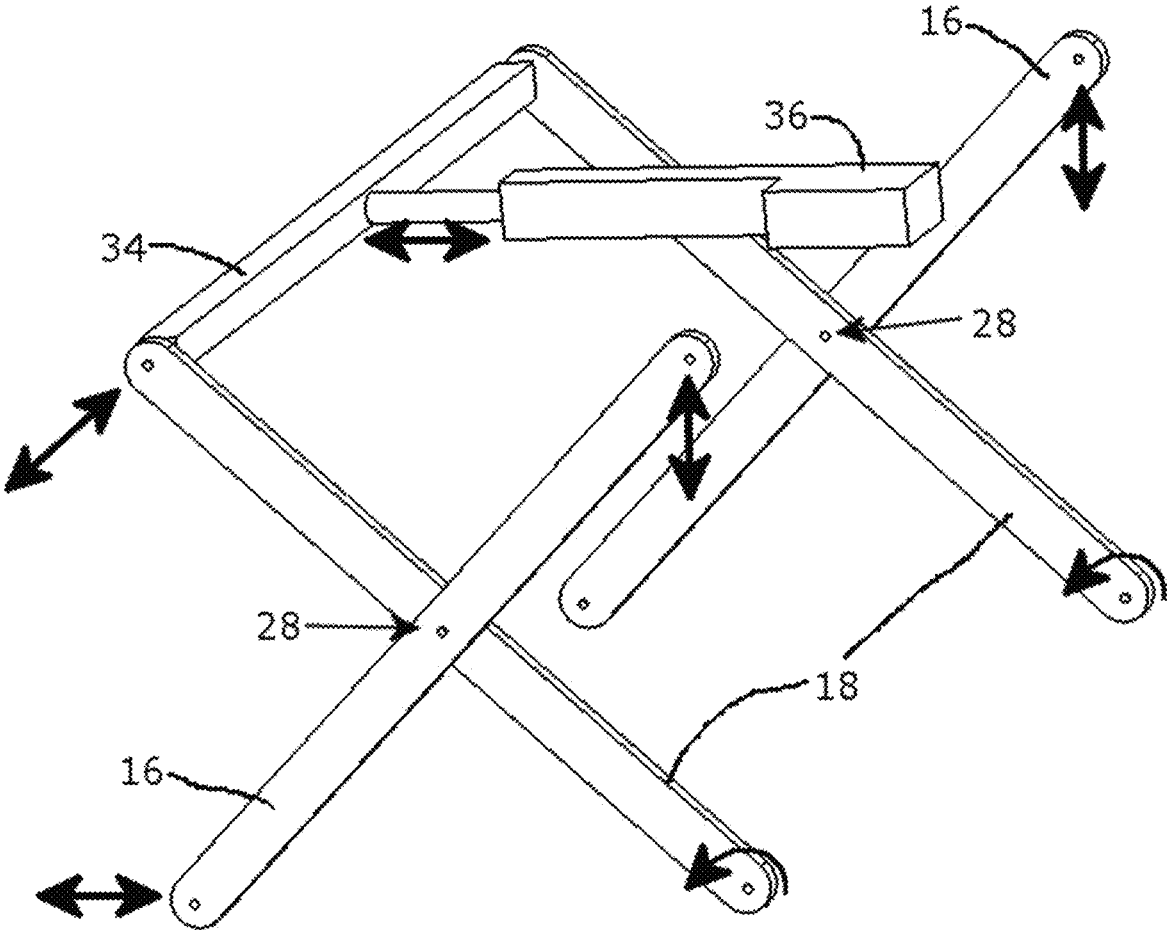

FIG. 4

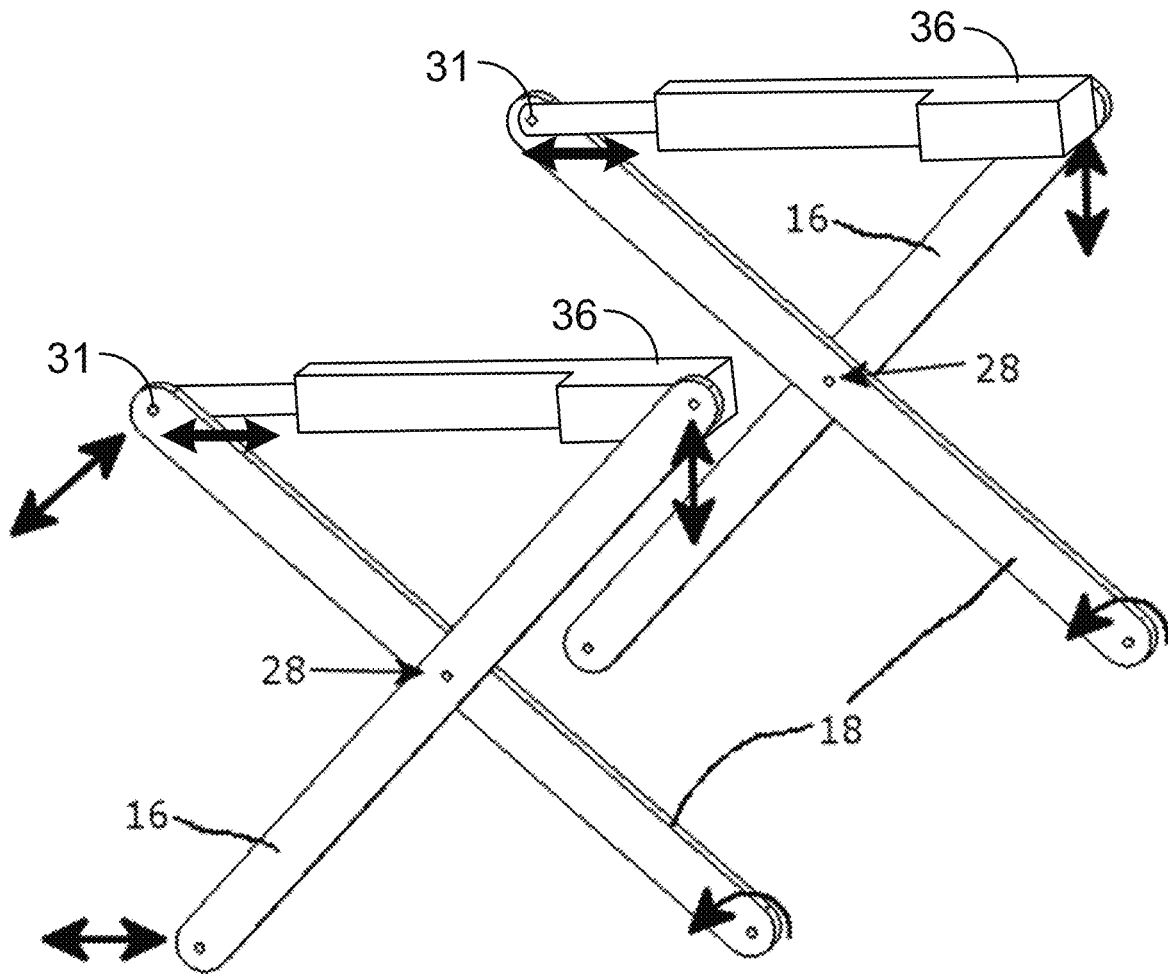

FIG. 4B

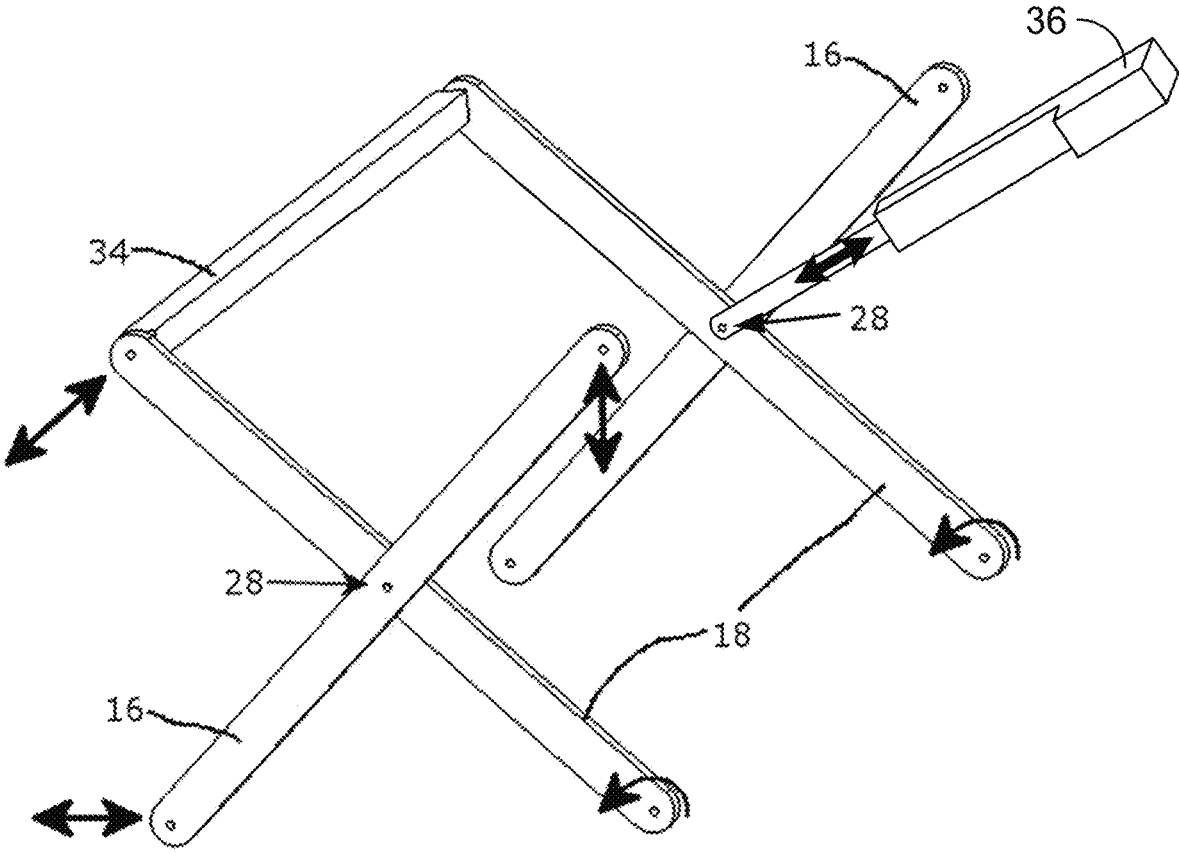

FIG. 4C

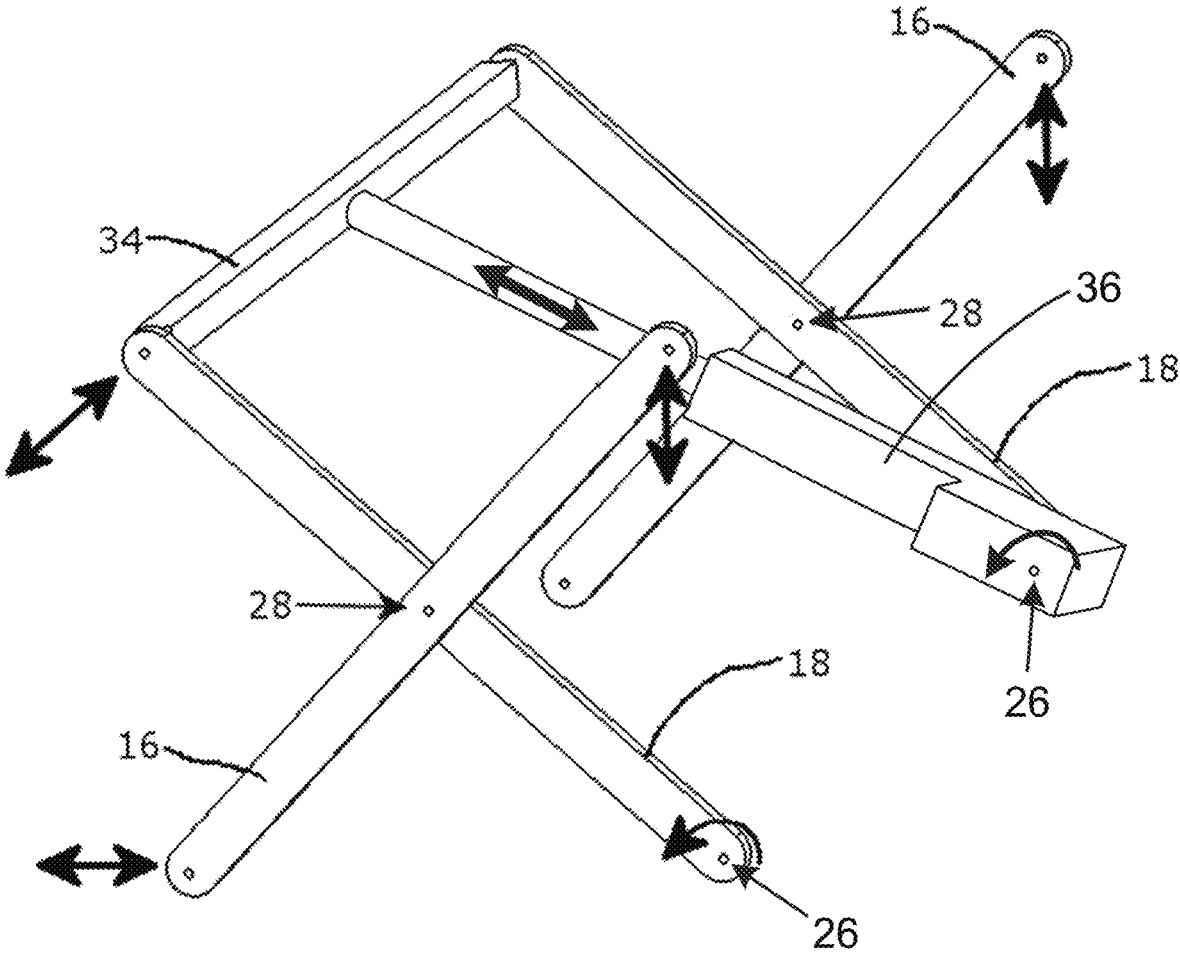

FIG. 4D

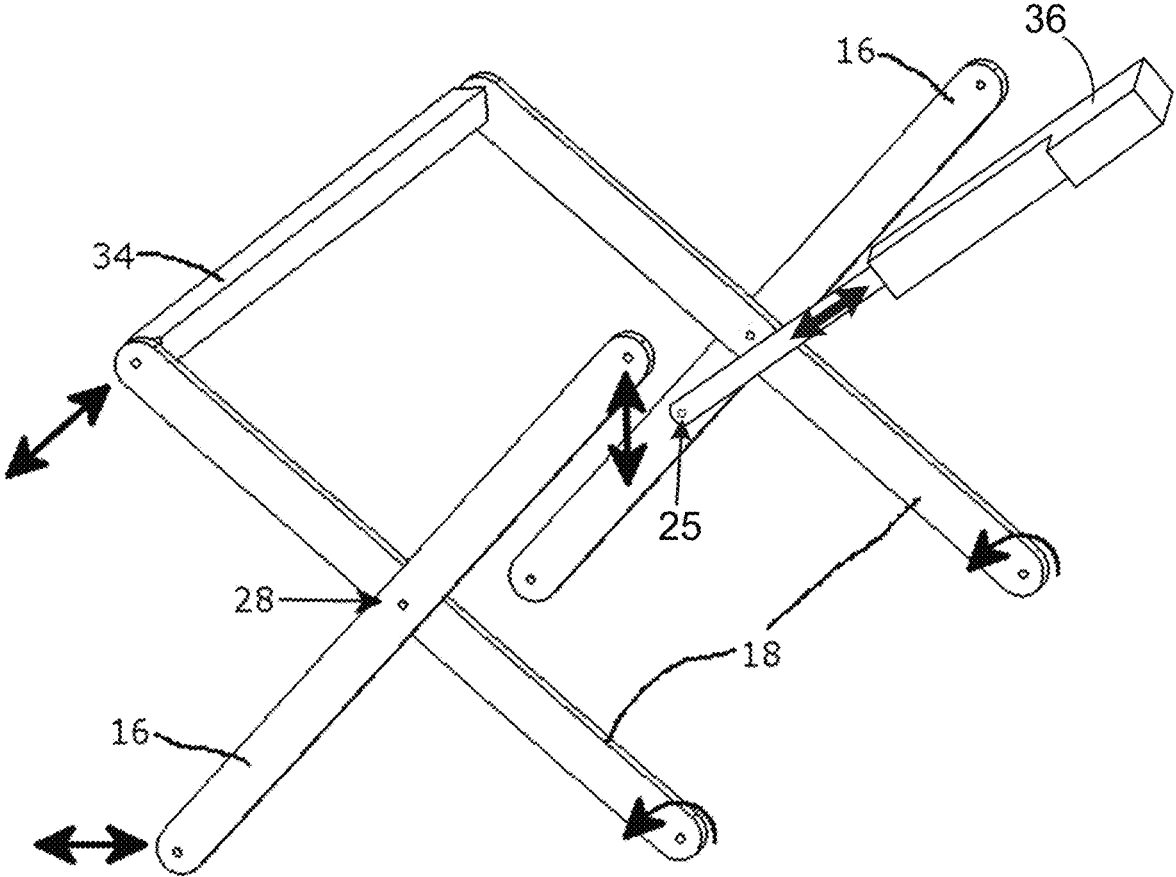

FIG. 4E

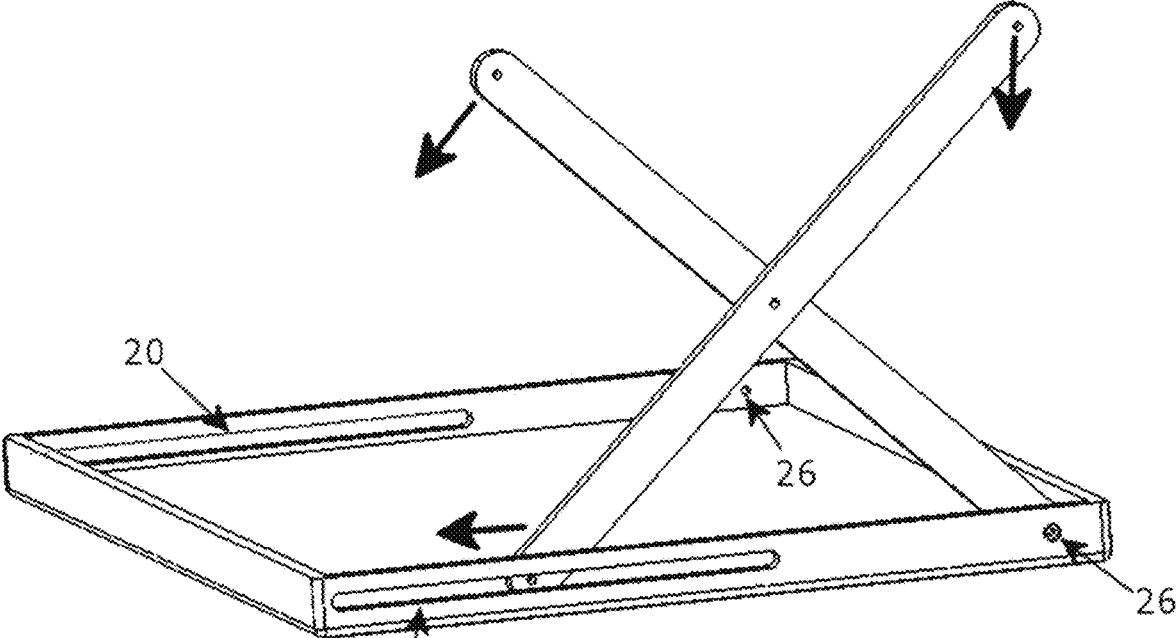

FIG. 5

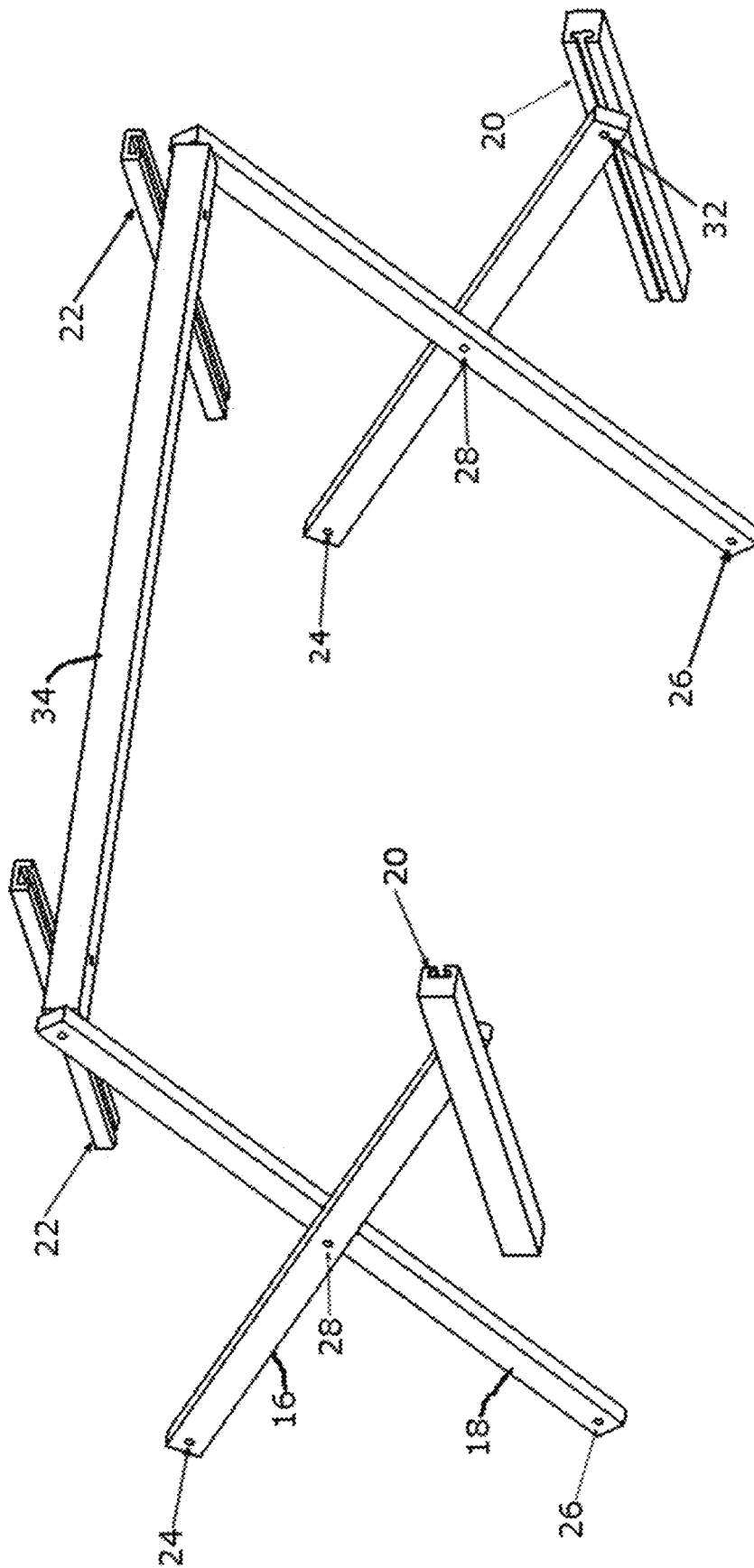

FIG. 5B

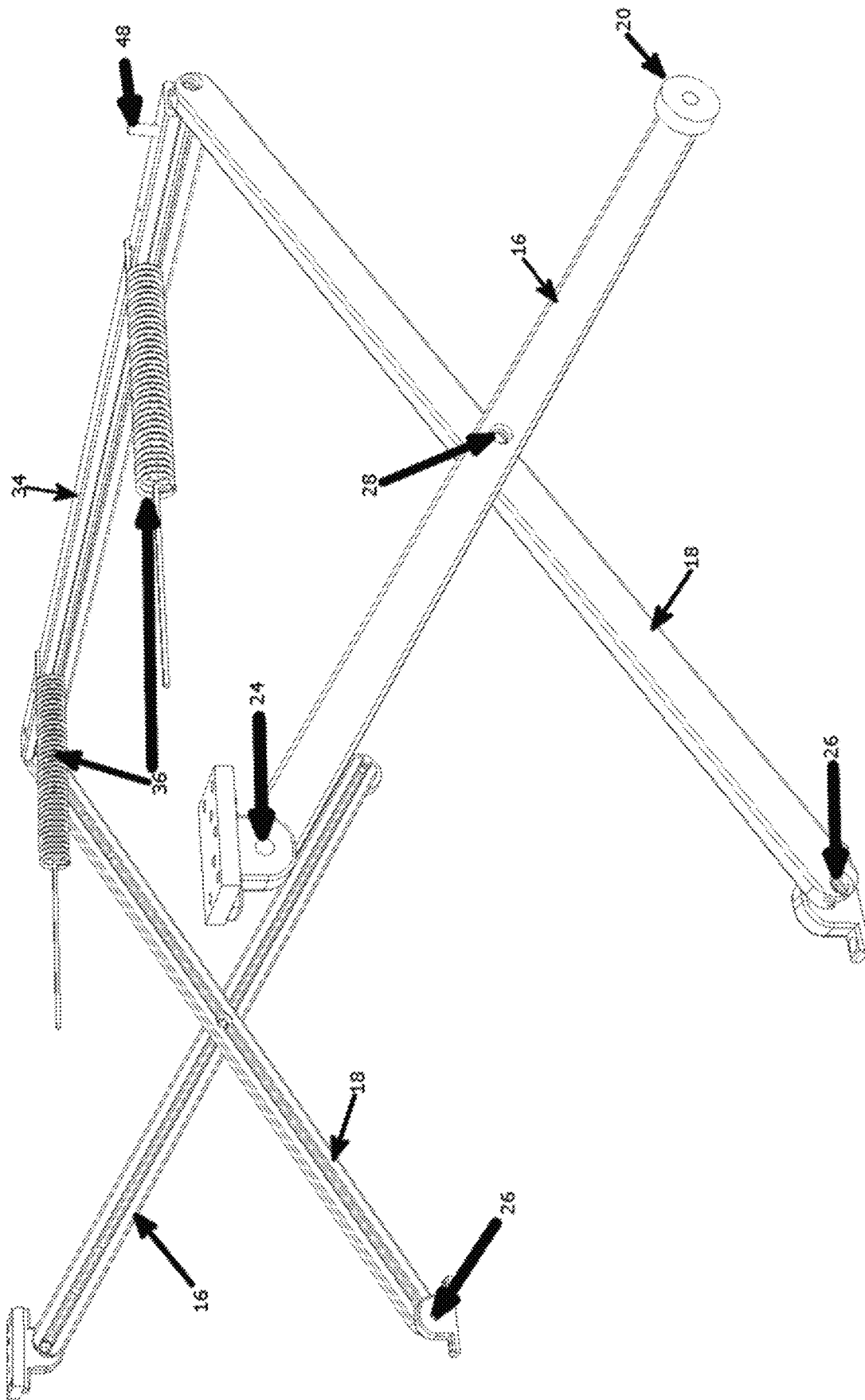

FIG. 5C

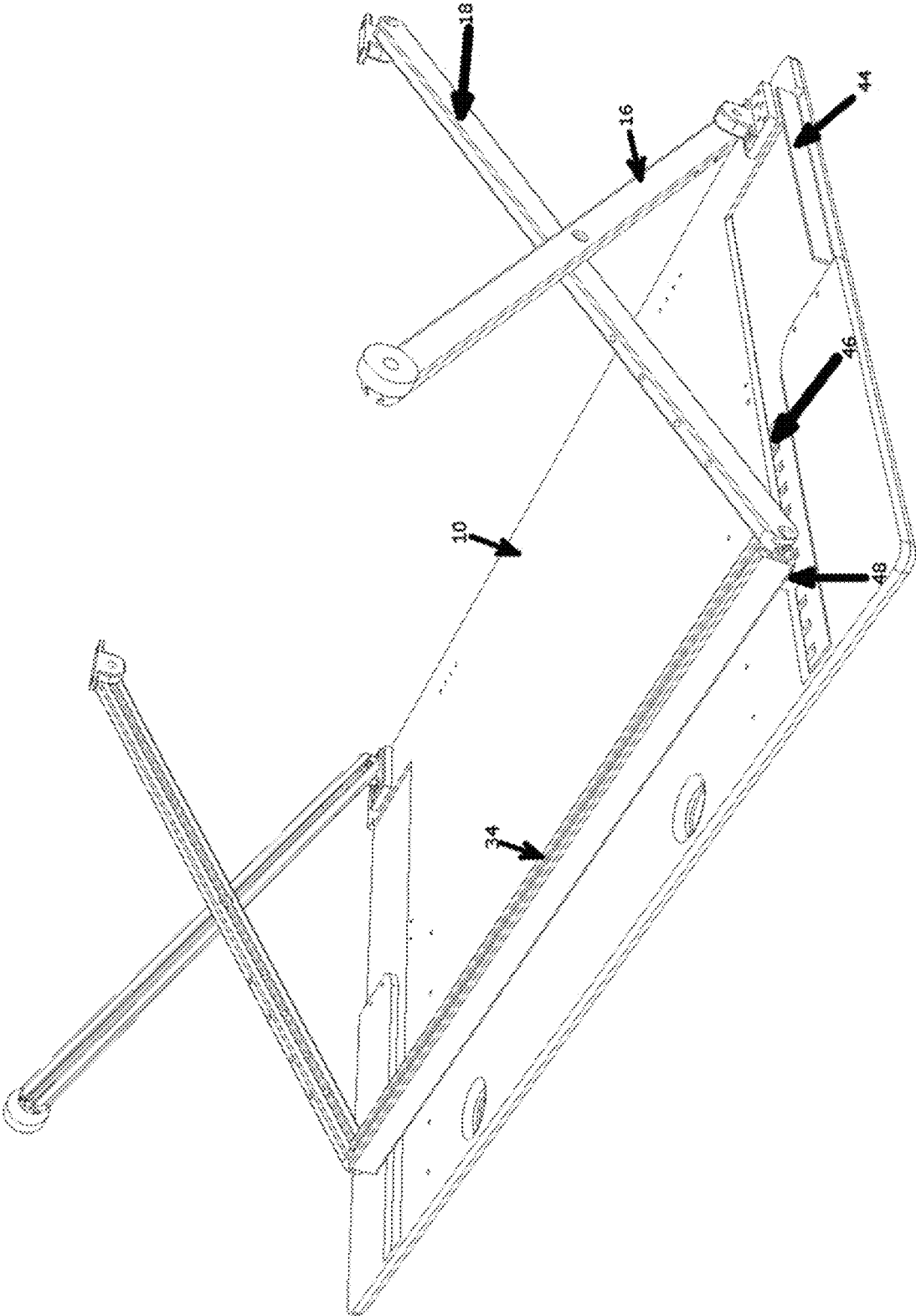

FIG. 5D

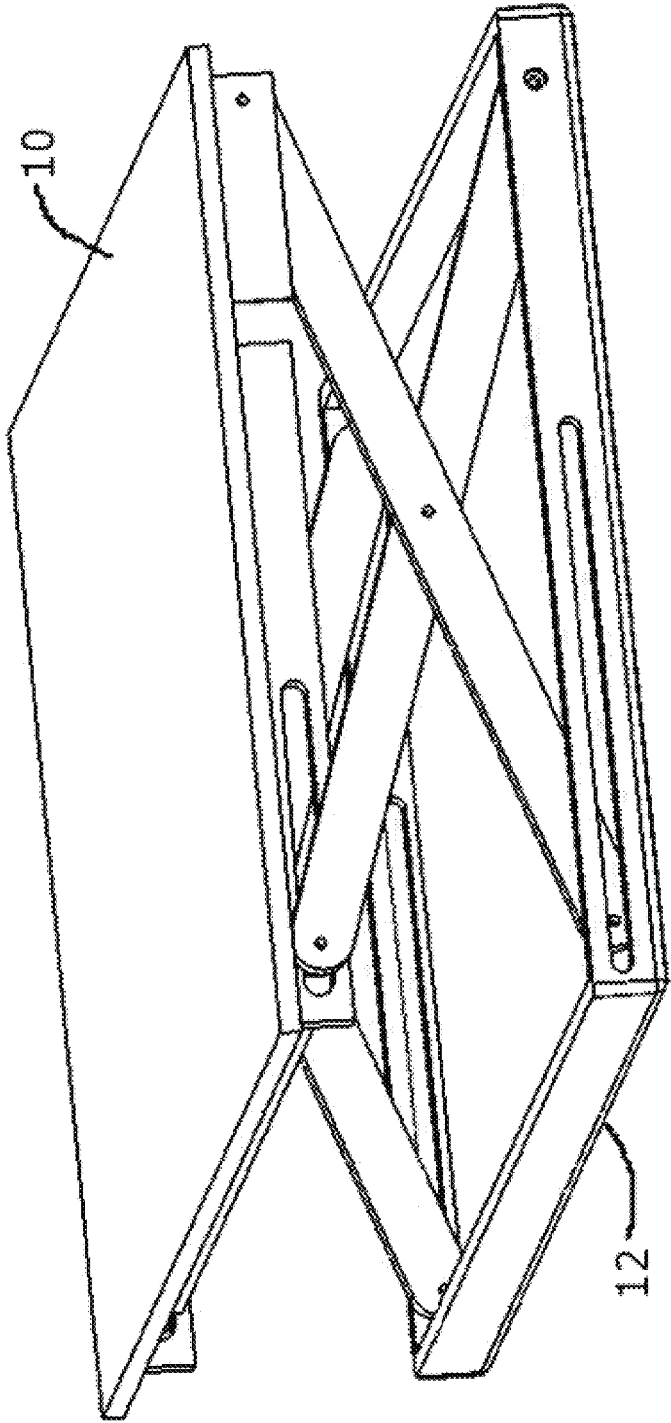

FIG. 6

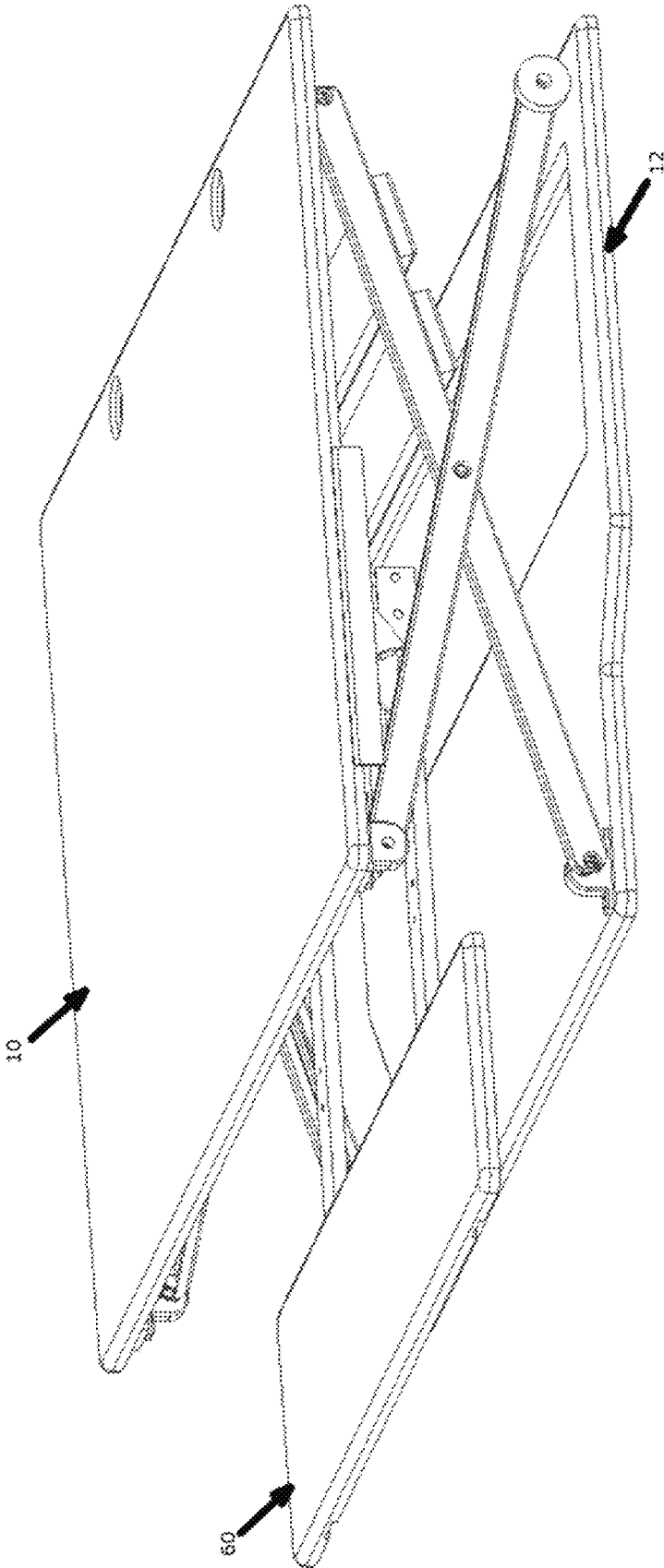

FIG. 68

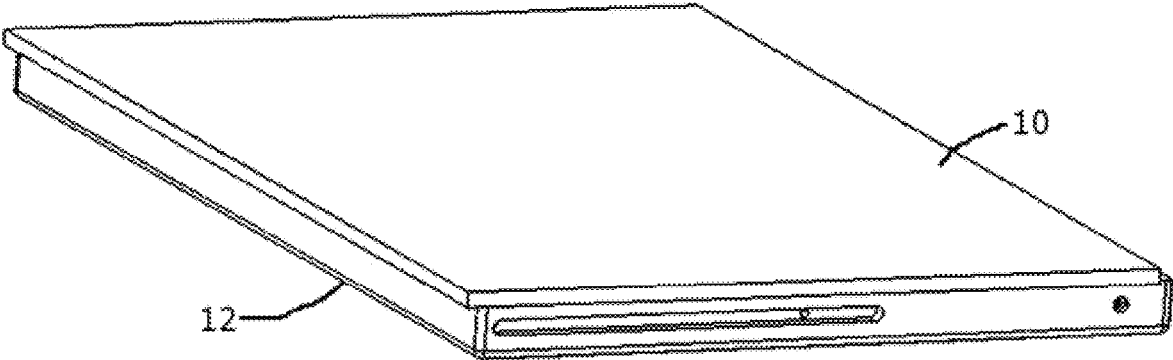

FIG. 7

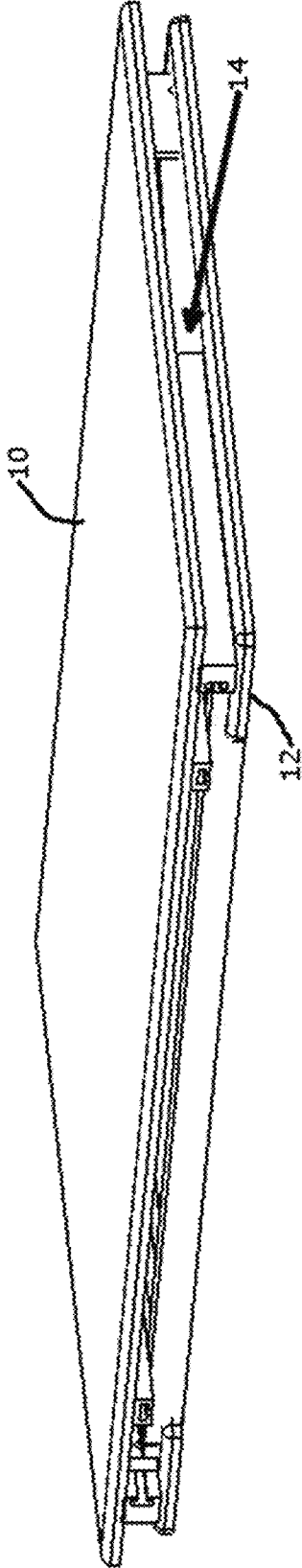

FIG. 7B

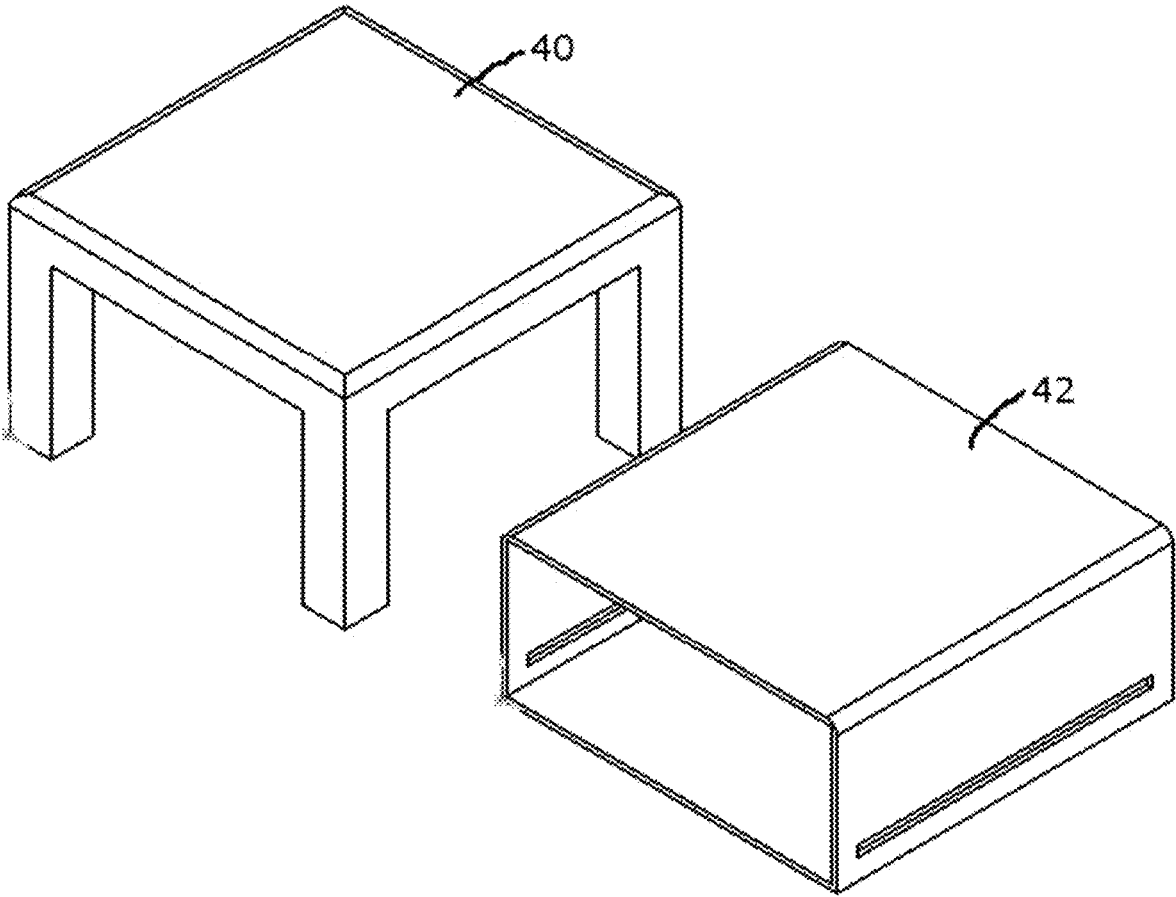

FIG. 8

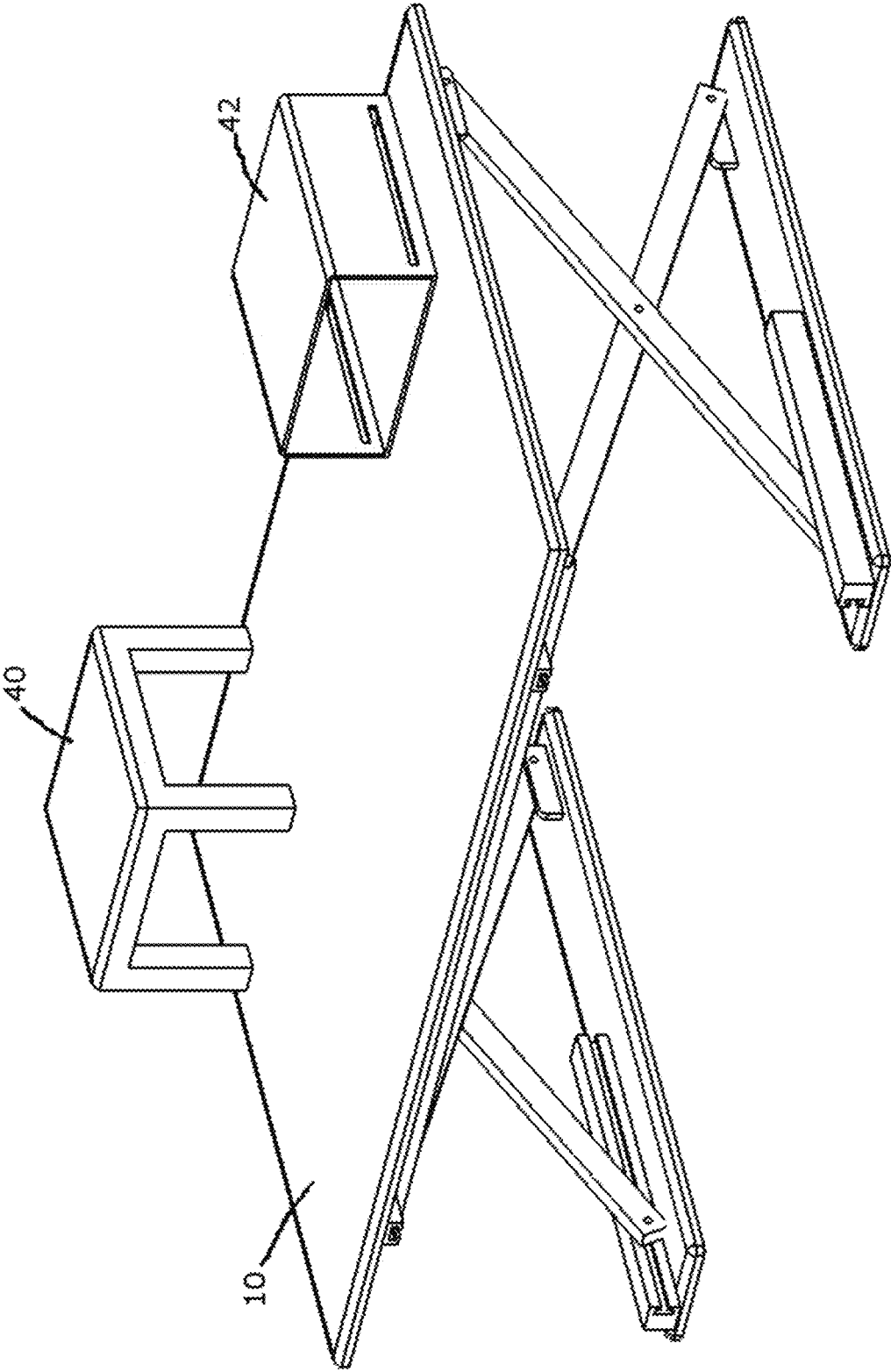

FIG. 9

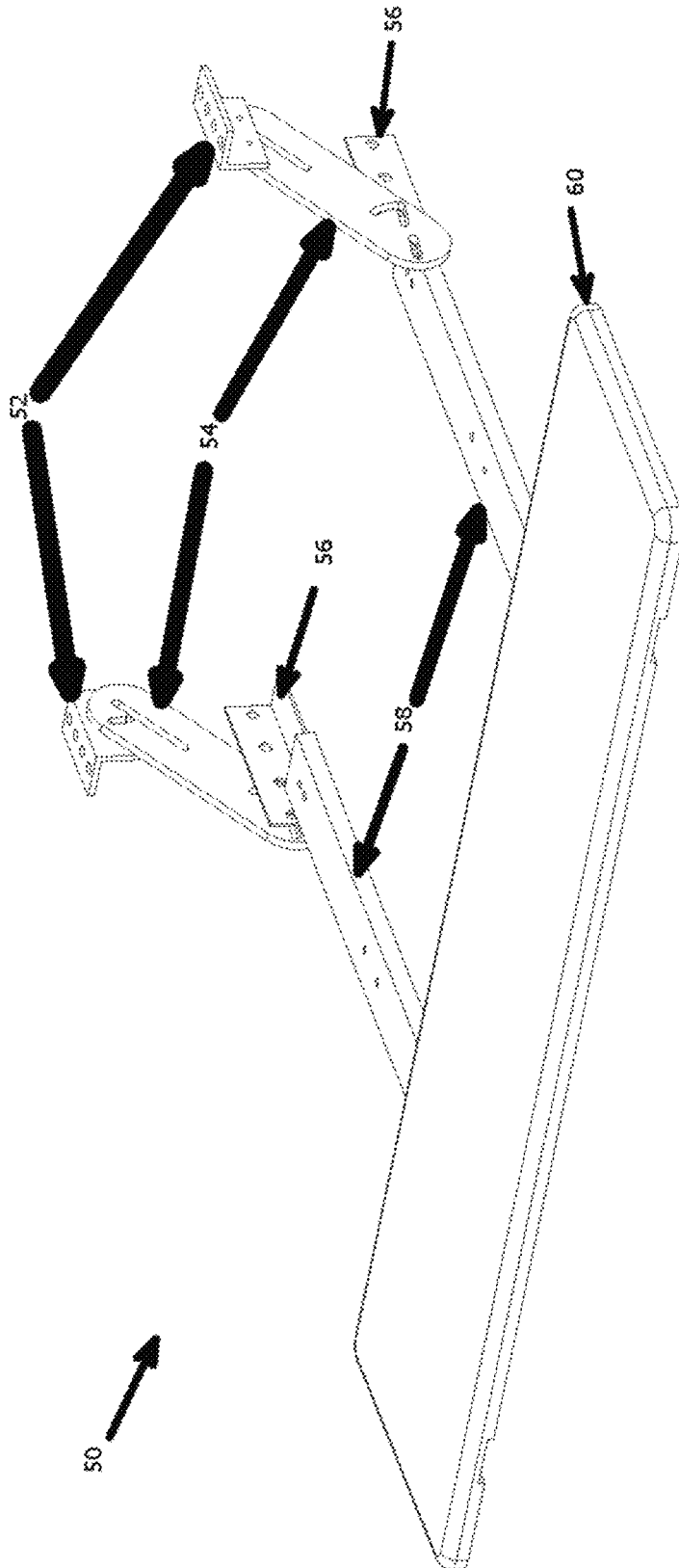

FIG. 10

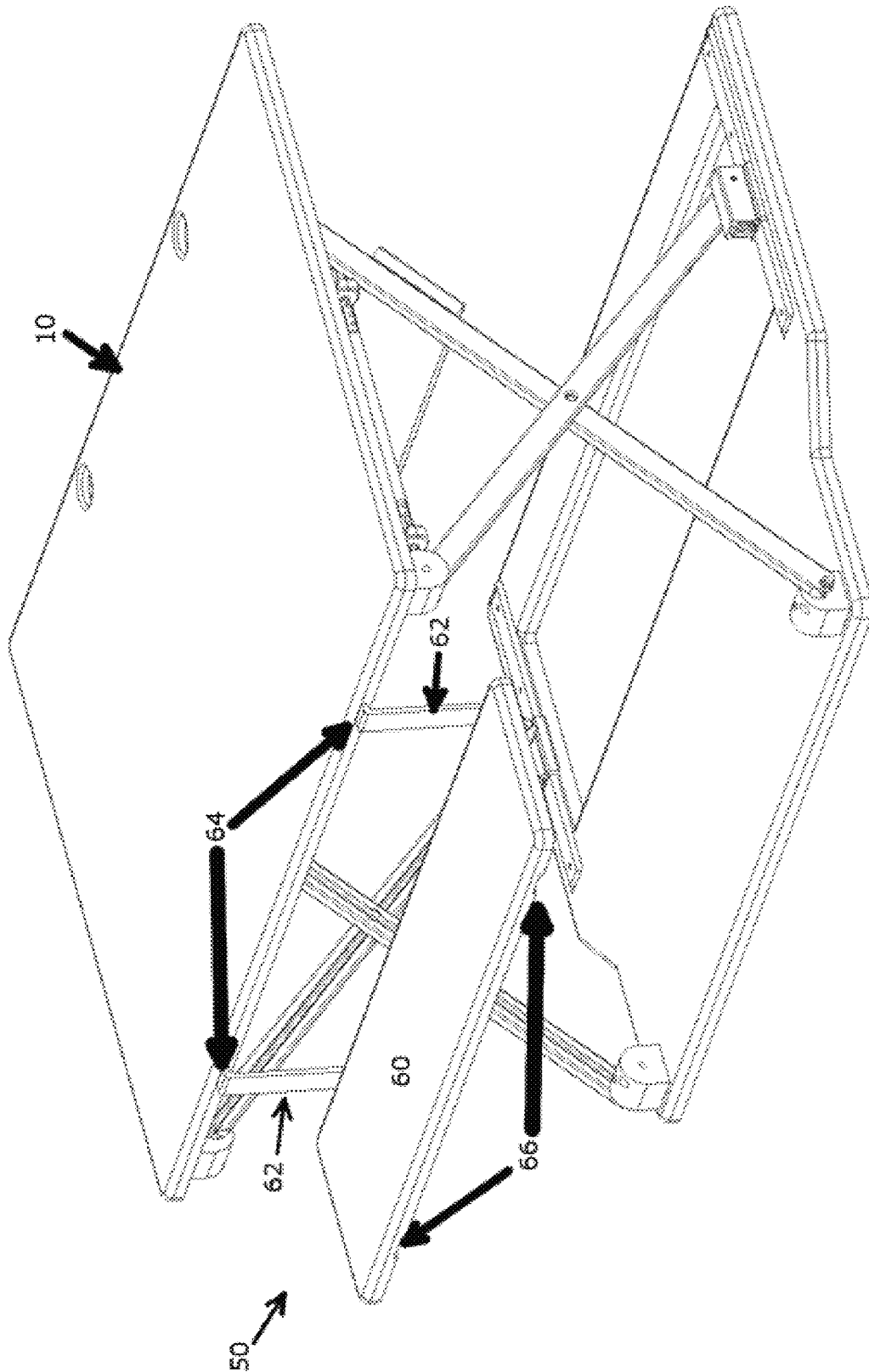

FIG. 10B

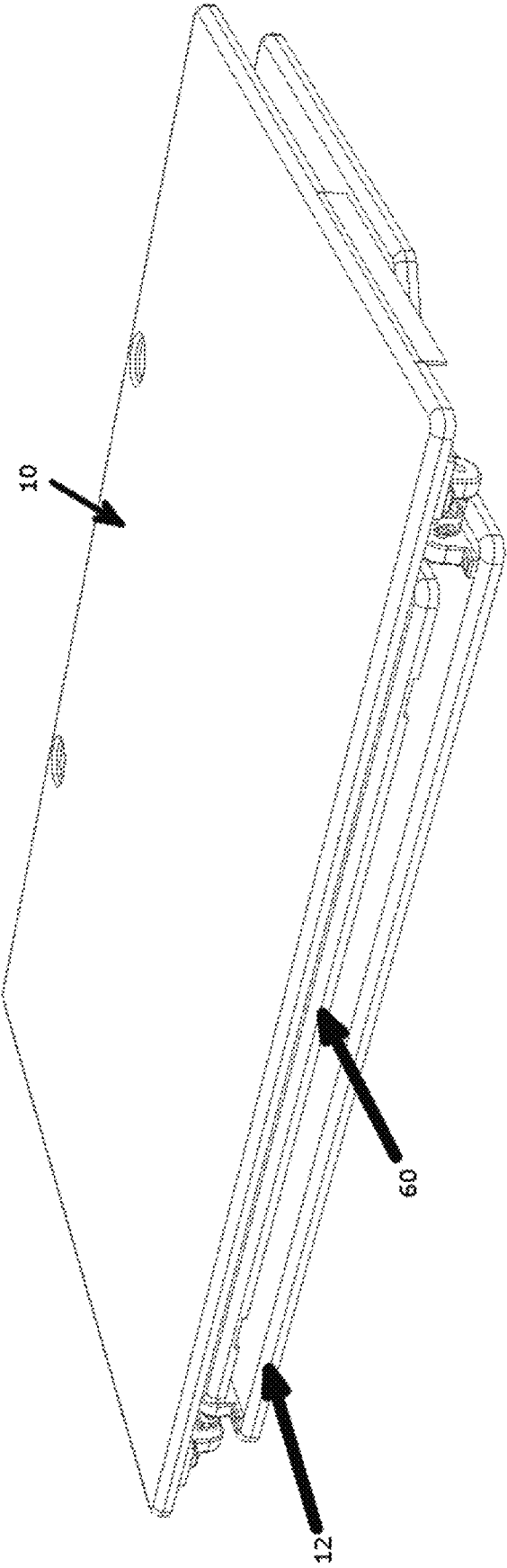

FIG. 10C

1

**DESKTOP WORKSPACE THAT ADJUSTS VERTICALLY****CROSS REFERENCE TO RELATED APPLICATIONS**

This application is a continuation application of U.S. patent application Ser. No. 18/481,082, titled DESKTOP WORKSPACE THAT ADJUSTS VERTICALLY, filed Oct. 4, 2023, which is a continuation application of U.S. patent application Ser. No. 17/985,137, titled DESKTOP WORKSPACE THAT ADJUSTS VERTICALLY, issued as U.S. Pat. No. 11,910,926 on Feb. 27, 2024, which is a continuation application of U.S. patent application Ser. No. 17/493,812, titled DESKTOP WORKSPACE THAT ADJUSTS VERTICALLY, issued as U.S. Pat. No. 11,944,196 on Apr. 2, 2024, 2024, which is a continuation application of U.S. patent application Ser. No. 16/785,647, titled DESKTOP WORKSPACE THAT ADJUSTS VERTICALLY, issued as U.S. Pat. No. 11,134,773 on Oct. 5, 2021, which is a continuation application of U.S. patent application Ser. No. 16/372,334, titled DESKTOP WORKSPACE THAT ADJUSTS VERTICALLY, issued as U.S. Pat. No. 10,575,630 on Mar. 3, 2020, which is a divisional application of Ser. No. 15/628,558, titled DESKTOP WORKSPACE THAT ADJUSTS VERTICALLY, issued as U.S. Pat. No. 10,244,861 on Apr. 2, 2019, which is a divisional application of U.S. patent application Ser. No. 15/004,926, titled DESKTOP WORKSPACE THAT ADJUSTS VERTICALLY, filed Jan. 23, 2016, now abandoned, which claims the benefit of U.S. Provisional Patent Application No. 62/107,380, titled DESKTOP WORKSPACE THAT ADJUSTS VERTICALLY, filed Jan. 24, 2015. The entire contents of each of these related applications is incorporated by reference herein.

**TECHNICAL FIELD**

This disclosure relates to a desktop workspace platform that adjusts up and down vertically.

**BACKGROUND**

In recent years studies have been conducted to show the health benefits of not sitting or standing for prolonged periods of time. It has been shown that sitting for long periods of time, day after day, increases the rate of all-cause mortality. It has even been said that sitting is the new smoking. A healthier work environment could be achieved by standing a portion of your day that you typically spend sitting. A combination of standing and sitting can reduce your risk of obesity, diabetes, cardiovascular disease and cancer.

There are many different types of work surfaces today. Most of these are stationary, in that they do not adjust in height. In recent years, entire desks that adjust in height have become more common. Most people already have a stationary desk, so purchasing an entire new desk may be unreasonable for some.

**SUMMARY**

There are a few adjustable desk platforms that sit on an existing desk, however, designs of such products have left much room for improvement. Some notable areas for improvement include, but are not limited to; the need for straight vertical motion of the desktop platform where the

2

work surface does not protrude out toward the operator when elevated, a motorized adjustable height mechanism or other motor assisted system, a holding or locking mechanism that does not limit the work surface to only preset heights, a higher maximum adjustable height to satisfy taller users, improved load distribution, improved design, improved appearance, increased load capacity, and a more compact design once in a lowered position.

A desktop workspace that adjusts vertically includes a work surface platform that acts as a work surface platform. A height adjustment mechanism allows the work surface platform to raise and lower to the desired height of the operator. This desktop workspace includes at least one set of arms as part of the height adjustment mechanism that utilizes a scissor motion to move the work surface platform up and down.

In one example, a desktop workspace that adjusts vertically is comprised of a work surface platform; a base configured to sit on an existing platform such as a desk; a height adjustable mechanism including at least one set of arms that connect at a pivot point creating a scissoring motion as part of the method to raise and lower the said work surface platform to various heights.

**BRIEF DESCRIPTION OF THE DRAWINGS**

FIG. 1 is a perspective view of an example adjustable desk including a work surface platform, base, and height adjustment mechanism.

FIG. 1B is a perspective view of an example adjustable desk including a work surface platform, base, and height adjustment mechanism, with alternative sliding mechanisms.

FIG. 1C is a perspective view of an example adjustable desk with alternative sliding mechanisms that incorporate rolling wheels, and a keyboard tray mechanism.

FIG. 1D is a perspective view of an example adjustable desk with alternative sliding mechanisms that incorporate rolling wheels, and a keyboard tray mechanism as shown in FIG. 1C, but without a base.

FIG. 2 is a perspective view from another angle of an example adjustable desk including a work surface platform, base, and height adjustment mechanism.

FIG. 2B is a perspective view from another angle of an example adjustable desk including a work surface platform, base, and height adjustment mechanism, with alternative sliding mechanisms.

FIG. 2C is a perspective view from another angle of an example adjustable desk with alternative sliding mechanisms that incorporate rolling wheels and a keyboard tray mechanism.

FIG. 2D is a perspective view an example adjustable desk with the alternative sliding mechanisms that incorporates rolling wheels and a keyboard tray mechanism as shown in FIG. 2C, but with gas springs rather than coil springs.

FIG. 3 is a side view of an example adjustable desk including a work surface platform, base, and height adjustment mechanism.

FIG. 3B is a side view of an example adjustable desk including a work surface platform, base, height adjustment mechanism, alternative sliding mechanisms, and a keyboard tray mechanism.

FIG. 4 is a perspective view of an example height adjustment mechanism from FIG. 1.

FIG. 4B is a perspective view of an example height adjustment mechanism as shown in FIG. 4, but without a cross beam.

3

FIG. 4C is a perspective view of an alternative height adjustment mechanism to that shown in FIG. 4.

FIG. 4D is a perspective view of an alternative height adjustment mechanism to that shown in FIG. 4.

FIG. 4E is a perspective view of an alternative height adjustment mechanism to that shown in FIG. 4.

FIG. 5 is a perspective view of parts of an example adjustable desk including sliding mechanism locations and pivot points of this disclosure from FIG. 1.

FIG. 5B is a perspective view of parts of an example of a height adjustment mechanism of this disclosure from FIGS. 1 and 1B with alternative sliding mechanisms.

FIG. 5C is a perspective view of parts of an example of a height adjustment mechanism from FIGS. 1 and 1B with alternative sliding mechanisms.

FIG. 5D is a perspective view of parts of an example of a height adjustment mechanism and locking mechanism from FIG. 1C.

FIG. 6 is a perspective view of an example adjustable desk wherein the work surface platform is in a partially raised state.

FIG. 6B is a perspective view of an example adjustable desk where the work surface platform is in a partially raised state with an example keyboard tray mechanism.

FIG. 7 is a perspective view of an example adjustable desk in a very compact state, with the work surface platform in a completely lowered position.

FIG. 7B is a perspective view of an example adjustable desk in a very compact state, with the work surface platform in a completely lowered position, with alternative sliding mechanisms.

FIG. 8 is a perspective view of example elements intended to additionally raise the height of monitors or other items.

FIG. 9 is a perspective view of an example adjustable desk with monitor raising elements resting on top of the work surface platform.

FIG. 10 is a perspective view of parts of an example of a keyboard tray mechanism.

FIG. 10B is a perspective view of an example adjustable desk with an alternative keyboard tray mechanism attached.

FIG. 10C is a perspective view of an example adjustable desk with keyboard tray mechanism attached and in a closed position.

#### DETAILED DESCRIPTION

The Desktop Workspace That Adjusts Vertically, also referred to as the “desktop workspace” in this document, includes a device and a method to raise and lower a platform that is part of the device. An exemplary use of the device is a work surface such as a desk, which can be moved to a desired vertical position. For example, the platform could hold objects such as a laptop, monitor, tablet, keyboard, mouse, and other desk items such as a stapler. The Desktop Workspace That Adjusts Vertically may include ancillary devices such as a monitor raiser, an external keyboard holder, mouse holder, cable organizer, or other devices. The platform raises vertically without protruding out along the horizontal plane, keeping the individual using the device from having to step backward to use the work surface platform when it is in a raised position. This configuration allows the operator to utilize the work surface platform at various heights. The examples and description suggest the device is used for supporting typical desktop objects, but the scope of this disclosure is intended to support other objects and to be used in other applications.

4

The Desktop Workspace That Adjusts Vertically can be placed on an existing surface to provide a variable height working area that is adjusted by the operator. The Desktop Workspace That Adjusts Vertically includes at least one set of two arms that connect along their lengths at a pivot point, allowing a scissoring motion, which is part of the method for raising and lowering the work surface platform. When raised, the work surface platform raises in a substantially straight motion so that it stays in-line with the base. An element or mechanism such as a spring or motor is configured to provide a force to assist in the elevation of the work surface platform. A locking mechanism is configured to secure the work surface platform at a given height.

The Desktop Workspace That Adjusts Vertically includes a height adjustment mechanism configured to assist in raising the work surface platform parallel to the surface it sits on, without moving back and forth or left to right; keeping the individual using the device from having to move backward to use the work surface platform when it is in a raised position. The height adjustment mechanism(s) may include items such as springs, gas springs, shock absorbers, an electric motor(s), or a linear actuator(s).

The Desktop Workspace That Adjusts Vertically is directed to help individuals from sitting or standing for prolonged periods of time while they work. Studies have shown that sitting or standing for long periods of time can be detrimental to one’s health.

The Desktop Workspace That Adjusts Vertically is designed to assist individuals to be more alert and productive as they work. Studies show that moving from a sitting to standing position and vice versa help the human body to be more awake and alert.

FIGS. 1, 1B, 1C, 2, 2B, 2C, 6, 7, 7B, 9, and 10C show examples of The Desktop Workspace That Adjusts Vertically an assembled state. As shown, the desktop workspace includes a work surface platform 10, a base 12, and a height adjustment mechanism 14 residing between the work surface platform 10 and base 12. The examples show that platform 10 is a work surface platform that supports desk items; for example, monitors, tablets, Computers, notebooks, and other objects. The height adjustment example 14 includes at least one set of two arms 16 & 18. Arms 16 & 18 are connected at some point along their shafts at pivot point 28. These pivoting arms connect at pivot points 24 and 26 on one end and slide along a sliding mechanism 20 or 22 at pivot and sliding point 30 or 32. The arms pivot at 28, arm 16 slides along 20 and arm 18 slides along 22, creating a scissor motion to allow the work surface platform 10 to move up and down. This example with the pivoting arms moving in the scissor motion is the basis of the height adjustment mechanism 14. Base 12 is the base that the height adjustment mechanism 14 connects to. Base 12 consists of one piece of material or multiple pieces of material. FIG. 1 portrays base 12 as one piece, while FIG. 1B portrays base 12 as two pieces, and FIG. 1C portrays base 12 as one piece with portions removed.

Base 12 is connected to pivot point 26 and sliding mechanism 20. Sliding mechanisms 20 and 22 could also be directly connected to the arm(s) in the form of a slider or wheel, as portrayed in FIG. 1C. The example in FIGS. 1 and 2 shows the present sliding mechanisms 20 and 22 as a groove cut through the wall of the supporting material. FIGS. 1B and 2B show another design of the present sliding mechanisms 20 and 22 as channel or track. FIGS. 1C and 2C show yet another design of the present sliding mechanisms 20 and 22 as a rolling device such as a wheel or bearing. All three are methods to illustrate that there is more than one

5

possible way to accomplish the intended sliding motion. Arm 16 attaches to the sliding mechanism 20 at point 32. Arm 16 moves back and forth along sliding mechanism 20 as part of the scissor motion used to obtain change in height of the work surface platform 10. The sliding action that sliding mechanisms 20 and 22 assist could be accomplished through means other than the illustrated examples, for example, a track system, roller wheel system, or some other means could be used to allow arm 16 and 18 to move in a back and forth motion. This disclosure is not intended to limit the means of the sliding motion, but to establish the fact that the sliding motion is part of the function of the adjustable height mechanism. The mentioned sliding motion is part of the overall scissor motion that is created by the design to vertically raise the work surface platform 10.

Pivot point 26 is the element that attaches the base 12 to arm 18. The examples in FIGS. 1 and 2 shows pivot 26 as being part of the wall of the base, and FIGS. 1B, 1C, 2B, and 2C shows pivot 26 as being a bracket or similar connected to base 12; pivot 26 could be located further in towards the center of base 12 and could be created as a stand-alone element such as a bracket or similar device. Pivot 26 is to be understood as a connection between base 12 and arm 18, and to be a pivot point that allows arm 18 to rotate as part of the scissor motion of height adjustment mechanism 14.

In some examples, the desktop workspace could exclude base 12, as shown in FIG. 1D. In such examples, height adjustment mechanism 14 connects directly to the desk or surface that the desktop workspace that adjusts vertically is sitting on. The lower portion of arm 18 connects directly to the surface with a pivot point similar to element 26. The lower portion of arm 16 connects to the surface and be guided to slide in a similar motion with an independent sliding mechanism such as, but not limited to, a track, channel, wheel, rail, or slot.

FIG. 4 shows an example of part of height adjustment mechanism 14, which assists in the vertical motion achieved to move the work surface platform 10 up and down in a smooth motion. Height adjustment 14 is designed so that it creates a vertical motion without any lateral or protruding motion side to side. Said another way, the scissor motion that height adjustment 14 creates allows work surface platform 10 to stay in alignment with base 12 as it raises or lowers. This alignment is intended, however some examples could include a method that does not align element 10 and 12 as raised and lowered.

Height adjustment mechanism 14 consists of one or more pairs of pivot arms 16 & 18, which have a pivoting point 28 at some point along their axis. Height adjustment mechanism 14 could also include a design where arms 16 & 18 do not actually connect at pivot point 28, but still provide a similar motion. Arm 16 connects at pivot element 24, and at point 32 which slide along sliding element 20. Similarly, arm 18 connects at pivot element 26 and at pivot point 30, which slides along sliding element 22. Height adjustment mechanism 14 also includes components that make the disclosure more rigid, such as cross beam supports labeled as element 68 in FIGS. 1C and 2C. Pivot arms, pivot points, and sliding elements are designed to fit compactly together when the desktop workspace is in a lowered position, as can be seen in FIGS. 7, 7B, and 10C. All elements align side-by-side in such a manner that when fully lowered the desktop workspace is very compact, looks sleek, and takes up minimal vertical space. The desktop workspace accomplishes such a compact state by having element 20 and 24 outside arm 16, which is outside arm 18, which is outside element 22. This arrangement of elements allows the ele-

6

ments' to not overlap when desktop workspace that adjusts vertically is in a fully lowered position providing a substantially compact state. The desktop workspace is not limited to specific elements or locations of elements to achieve the height adjustment motion that results in a compact design where elements do not overlap.

The illustrated examples of FIGS. 1 and 1B suggests that pivot points 26 and 24 are located in the back of desktop workspace, and that sliding mechanisms 20 and 22 are located in the front. The illustrated examples of FIG. 1C suggests that pivot points 26 and 24 are located in the front of the desktop workspace and that sliding mechanisms 20 and 22 are located in the back. Some examples include a design where the pivot points and sliding mechanisms are at opposite sides, or some combination of both.

As can be seen in FIGS. 2, 2B, 2C, 4, 5B, and 5C pivoting arms, are attached to a cross beam 34. Cross beam 34 assists in stabilizing the invention and assist all elements of the height adjustment mechanism to move in concert when a force is applied. The force can be applied from various methods and on various points of cross beam 34, pivot arms 16 & 18, pivot elements 26 & 24, or sliding mechanisms 20 or 22. FIG. 4D is a perspective view of an example height adjustment mechanism as shown in FIG. 4, but with element 36 connected on a point of cross beam 34 to one of pivot elements 26. FIG. 4E is a perspective view of an example height adjustment mechanism as shown in FIG. 4, but with element 36 connected to one of pivot arms 16 via an arm pivot 25. Some examples include a design where element 34 does not span across the mechanism connecting all or some of the arms.

FIG. 4 shows the force being applied by element 36 to cross beam 34. Element 36 can apply a pushing and pulling force to cross beam 36, which causes pivot arms 16 and 18 to move in a scissor motion. The example is intended to suggest that element 36, which applies force to height adjustment mechanism 14, can be a variety of different mechanisms, elements, or represent manual human force. For example, the force that element 36 provides could come from; a linear actuator, AC or DC motor, human force, gravity, springs, other objects with kinetic energy, or another source of force. For example, FIG. 4 illustrates element 36 as a linear actuator, while FIG. 5C illustrates element 36 as a pair of springs.

The combination of height adjustment mechanism 14 and a force represented by element 36, create the scissor motion that moves the work surface platform vertically up and down. Examples portrayed in FIGS. 4, and 5 show the scissor motion of height adjustment mechanism 14.

Examples can utilize element 36 or similar element in a different location; for example, the element could attach directly to arms 16 or 18, or to one of the pivot points, instead of to element 34. Some examples may not include element 34 or the like, where such a crossbeam or connection is not deemed necessary. FIG. 4B is a perspective view of an example height adjustment mechanism as shown in FIG. 4, but without a cross beam 34. In FIG. 4B, elements 36 attach directly to arms 18 through arm pivot points 31, instead of to element 34. FIG. 4C is a perspective view of an example height adjustment mechanism as shown in FIG. 4, but with element 36 connected to one of the scissoring pivot points 28 instead of to cross beam 34.

Examples in FIGS. 4, and 5 include arrows that show some of the possible motions of mechanism 14. Pivot arms are connected to one another at pivot point 28. As one end of arm 16 moves along sliding mechanism 20, the other end of the arm moves up or down vertically. When arm 18 pivots

at point **26**, the other end of the arm slides along sliding mechanism **22**, which can be seen in FIGS. **2**, **2B**, and **2C** and moves up and down vertically.

The height adjustment mechanism moves vertically and is held or locked into position at various heights. Examples of the height adjustment mechanism use various methods to lock or hold in place. For example, element **36** acts as the locking device, or the locking device can be included in sliding mechanism(s) **20** & **22**, or the locking device can be included in pivot point(s) **26** and **24**, or the locking mechanism could entail another element not mentioned. FIG. **5D** portrays a locking device that could include element **34** or other element engaging with element **44**. Pins or other element, portrayed as element **48**, engage with teeth or other element, portrayed as element **46** to lock the height adjustment mechanism in a desired position. The locking element can include, but not limited to, a linear actuator, a motor, applied pressure, locking teeth, or some other method to prevent arms **16** and **18** from moving, so that work surface platform **10** does not change vertical height. Applications utilizing a linear actuator or similar can allow the operator to adjust the height without the limitations of preset heights that some locking mechanisms only provide. Instead of preset heights created by an element with features such as preset holes, the linear actuator or something similar would allow the operator to set the height limit by stopping the linear actuator or similar at any point the operator chooses. The desktop workspace includes a locking mechanism that maintains the vertical position of surface **10**; the examples are not limited to specific elements to achieve the height locking function.

Examples include a means to unlock the device so that the work surface platform **10** can change height. Examples can include, but not limited to, a button(s) to control a motor or the like, a handle that the user pulls on to unlock the device, or another device that unlocks the locking device. FIG. **5D** portrays an example of a locking mechanism where element **44** acts as a handle that once pressure is applied to can both lock and unlock the height adjustment mechanism by engaging or disengaging the teeth, element **46** or similar to pin, element **48** or similar. Unlocking elements are suggested, however, examples are not limited to specific elements to achieve the unlocking function.

The example shows sliding element(s) **22** and pivot element(s) **24** connect the height adjustment mechanism **14** to the work surface platform **10**. The example allows for the work surface platform to be raised and lowered, as well as locked into the desired position of the individual using the desktop workspace. This allows the user to utilize the desktop workspace that adjusts vertically while in a seated position or a standing position.

FIG. **8** portrays the current design of elements **40** and **42**, which could be used to elevate a monitor, laptop, or other items to a level higher than that of work surface platform **10**. Additionally raising a monitor can create a more comfortable and healthier work space for the operator by bringing their screen(s) to a position closer to eye level. FIG. **9** shows elements **40** and **42** sitting on work surface platform **10**. Elements **40** and **42** are presently designed to be able to sit anywhere on surface **10**. Examples are not intended to limit the design of elements **40** and **42**. Elements **40** and **42** are intended to represent a method in which a monitor(s) can be elevated to height higher than if it were sitting on work surface platform **10**. It is to be understood that element **40** or **42** could be designed differently and still accomplish its function to raise the height of a monitor(s) or other items.

FIGS. **10**, and **10B** show an example of part of keyboard tray mechanism **50**, which provides a platform for the user to place items such as a keyboard, mouse, or other items on. Keyboard mechanism **50** is configured move to a position that is in an outward and lowered position with respect to surface **10**. Such a position can provide a more ergonomic location of the keyboard and mouse for the user. Some examples include a design where the keyboard tray can be removed, adjusted, or designed so that it extends out when is in use and is compactly stored under surface **10** when not in use.

FIGS. **10** and **10C** show an example of Keyboard tray **50** where it is configured to move underneath and flush with surface **10** to allow this disclosure to maintain its compact state once in a closed position. Bracket **52** connects to channel plate component **54**, which connects to bracket **56**, which connect to slider **58**, which connect to keyboard platform **60**. When the user applies an inward and upward force to platform **60**, channeled plate component **54** and slider **58** allow the keyboard tray mechanism to move to a position that is compactly positioned underneath platform **10** as portrayed in FIG. **10C**. Conversely, when an outward and downward force is applied to platform **10**, elements **52**, **54**, **56**, and **58** allow mechanism **50** to be in an out and down position as portrayed in FIGS. **1C** and **2C**. Said more specifically, plate **54** contains channels or grooves that guide brackets **52** and **54** connect to with pins, screws, or similar. When the user pulls or pushes up, down, in, or out on the platform **60**, the channels or grooves in plate **54** along with the sliding motion of slider **58** guide the platform to either rest in an outward state for typing or tucked away under the work surface platform **10**.

FIG. **10B** shows an example of keyboard tray mechanism **50** that attach to platform **10**. Bracket **62** attaches to platform **10** at element **64** and keyboard platform **60** at element **66**. Element **64** and **66** consists of a channel, bracket, or other means to attach bracket **62** to both platform **10** and platform **60**.

Elements for keyboard tray mechanism **50** are suggested, however, examples are not limited to specific elements to achieve the function of the keyboard tray mechanism.

The intention of the different examples discussed is not intended to limit the scope of this disclosure. The description and terminology is not intended to limit the scope and applicability of this disclosure. It should be understood that other terminology, parts, components, and layouts could be used that would still embody the intentions of this disclosure. Individuals skilled in the art will recognize that examples described have suitable alternatives. It is also noted that the examples are not limited to specific construction materials, and that various suitable materials exist for the elements of this disclosure.

What is claimed is:

1. A desktop workspace that adjusts vertically, comprising:

a work surface platform;  
a base configured to sit on an existing platform;  
a height adjustment mechanism connecting the work surface platform and the base, the height adjustment mechanism including:

a set of pivot arms including a base pivot arm pivotably connected to the base and a platform pivot arm pivotably connected to the work surface platform, the base pivot arm pivotably connected to the platform pivot arm to provide a scissoring motion when raising and lowering the work surface platform to various heights;

9

- a first sliding mechanism on an end of the platform pivot arm between the end of the platform pivot arm and the base; and
- a second sliding mechanism on an end of the base pivot arm between the end of the base pivot arm and the work surface platform; and
- a force applying mechanism attached to the height adjustment mechanism to provide a force to assist in elevation of the work surface platform,
- wherein the force applying mechanism is a spring that acts as a locking device that holds the work surface platform at various heights above the base,
- wherein the force applying mechanism is adjacent an underside of the work surface platform and extends between an underside of the work surface platform and the height adjustment mechanism along a direction generally parallel to a work surface of the work surface platform.
2. The desktop workspace of claim 1, wherein the base pivot arm is a first base pivot arm, the height adjustment mechanism further comprising:
- a second base pivot arm; and
  - an element that connects the first base pivot arm to the second base pivot arm,
- wherein the force applying mechanism is attached to the element.
3. The desktop workspace of claim 2, wherein the element is attached on the same side of the base pivot arm as the second sliding mechanism relative to the pivot connection between the base pivot arm and the platform pivot arm.
4. The desktop workspace of claim 2, wherein the element includes a cross beam.
5. The desktop workspace of claim 1, wherein the platform pivot arm is a first platform pivot arm, the height adjustment mechanism further comprising a second platform pivot arm.
6. The desktop workspace of claim 1, wherein the scissoring motion when raising and lowering the work surface platform to various heights of the height adjustment mechanism moves the work surface platform parallel to the existing platform.
7. The desktop workspace of claim 6, wherein the scissoring motion when raising and lowering the work surface platform to various heights of the height adjustment mechanism moves the work surface platform without moving back and forth or left to right.
8. The desktop workspace of claim 1, further comprising a keyboard platform that protrudes out, down, and parallel to the work surface platform.
9. The desktop workspace of claim 8, further comprising a keyboard tray mechanism configured to hold the keyboard platform in the position that protrudes out, down, and parallel to the work surface platform and to allow the keyboard platform to be stored under the work surface platform.
10. The desktop workspace of claim 1, wherein the locking device includes a user-operated handle for controlling the locking device.
11. The desktop workspace of claim 1, further comprising a keyboard holder.
12. The desktop workspace of claim 1, wherein the force applying mechanism is configured to apply pushing and pulling forces to move the set of pivot arms in the scissoring motion.

10

13. The desktop workspace of claim 1, wherein the force to assist in elevation of the work surface platform extends along the direction generally parallel to the work surface of the work surface platform.
14. The desktop workspace of claim 1, wherein the force applying mechanism acts as a locking device that holds the work surface platform at any various height above the base chosen by a user.
15. A desktop workspace that adjusts vertically, comprising:
- a work surface platform;
  - a base configured to sit on an existing platform;
  - a height adjustment mechanism connecting the work surface platform and the base, the height adjustment mechanism including:
    - a set of pivot arms including a base pivot arm pivotably connected to the base and a platform pivot arm pivotably connected to the work surface platform, the base pivot arm pivotably connected to the platform pivot arm to provide a scissoring motion when raising and lowering the work surface platform to various heights;
    - a first sliding mechanism on an end of the platform pivot arm between the end of the platform pivot arm and the base; and
    - a second sliding mechanism on an end of the base pivot arm between the end of the base pivot arm and the work surface platform;
  - a force applying mechanism attached to the height adjustment mechanism to provide a force to assist in elevation of the work surface platform,
- wherein the force applying mechanism is adjacent an underside of the work surface platform and extends between an underside of the work surface platform and the height adjustment mechanism along a direction generally parallel to a work surface of the work surface platform; and
- a locking device that holds the work surface platform at various heights above the base,
- wherein the locking device includes a handle that a user pulls on to unlock the locking device.
16. A desktop workspace that adjusts vertically, comprising:
- a work surface platform;
  - a base configured to sit on an existing platform;
  - a height adjustment mechanism connecting the work surface platform and the base, the height adjustment mechanism including:
    - a set of pivot arms including a base pivot arm pivotably connected to the base and a platform pivot arm pivotably connected to the work surface platform, the base pivot arm pivotably connected to the platform pivot arm to provide a scissoring motion when raising and lowering the work surface platform to various heights;
    - a first sliding mechanism on an end of the platform pivot arm between the end of the platform pivot arm and the base; and
    - a second sliding mechanism on an end of the base pivot arm between the end of the base pivot arm and the work surface platform; and
  - a force applying mechanism attached to the height adjustment mechanism to provide a force to assist in elevation of the work surface platform,
- wherein the force applying mechanism comprises a motorized linear actuator,

11

wherein the force applying mechanism is adjacent an underside of the work surface platform and extends between an underside of the work surface platform and the height adjustment mechanism along a direction generally parallel to a work surface of the work surface platform.

17. A desktop workspace that adjusts vertically, comprising:

- a work surface platform;
  - a base configured to sit on an existing platform;
  - a height adjustment mechanism connecting the work surface platform and the base, the height adjustment mechanism including:
    - a set of pivot arms including a base pivot arm pivotably connected to the base and a platform pivot arm pivotably connected to the work surface platform, the base pivot arm pivotably connected to the platform pivot arm to provide a scissoring motion when raising and lowering the work surface platform to various heights;
    - a first sliding mechanism on an end of the platform pivot arm between the end of the platform pivot arm and the base; and
    - a second sliding mechanism on an end of the base pivot arm between the end of the base pivot arm and the work surface platform; and
  - a force applying mechanism attached to the height adjustment mechanism to provide a force to assist in elevation of the work surface platform,
- wherein the force applying mechanism comprises a motor,
- wherein the force applying mechanism is adjacent an underside of the work surface platform and extends between an underside of the work surface platform and the height adjustment mechanism along a direction generally parallel to a work surface of the work surface platform.

12

18. A desktop workspace that adjusts vertically, comprising:

- a work surface platform;
  - a base configured to sit on an existing platform;
  - a height adjustment mechanism connecting the work surface platform and the base, the height adjustment mechanism including:
    - a set of pivot arms including a base pivot arm pivotably connected to the base and a platform pivot arm pivotably connected to the work surface platform, the base pivot arm pivotably connected to the platform pivot arm to provide a scissoring motion when raising and lowering the work surface platform to various heights;
    - a first sliding mechanism on an end of the platform pivot arm between the end of the platform pivot arm and the base; and
    - a second sliding mechanism on an end of the base pivot arm between the end of the base pivot arm and the work surface platform; and
  - a force applying mechanism attached to the height adjustment mechanism to provide a force to assist in elevation of the work surface platform,
- wherein the force applying mechanism is adjacent an underside of the work surface platform and extends between an underside of the work surface platform and the height adjustment mechanism along a direction generally parallel to a work surface of the work surface platform,
- wherein the force applying mechanism, the set of pivot arms, the base pivot arm connection to the base, and the platform pivot arm connection to the platform are positioned side-by-side when the desktop workspace is in a fully lowered position.

\* \* \* \* \*