



US007664501B2

(12) **United States Patent**
Dutta et al.

(10) **Patent No.:** **US 7,664,501 B2**
(45) **Date of Patent:** **Feb. 16, 2010**

(54) **SEAMLESS HANDOFF ACROSS
HETEROGENEOUS ACCESS NETWORKS
USING A HANDOFF CONTROLLER IN A
SERVICE CONTROL POINT**

(58) **Field of Classification Search** 455/436,
455/428, 422.1, 442, 456.5, 426.2, 445; 370/352,
370/493, 331
See application file for complete search history.

(76) Inventors: **Ashutosh Dutta**, 349 Greenfield Rd.,
Bridgewater, NJ (US) 08807; **Subir Das**,
3500 Barrett Dr., Apt #16E, Kendall
Park, NJ (US) 08824; **Donald R.
Lukacs**, 56 Washington St., Apt. B, Red
Bank, NJ (US) 07701; **Tao Zhang**, 247
Harmon Ave., Fort Lee, NJ (US) 07024;
David C. Shrader, 304 W. 18th St., #1,
New York, NY (US) 10011; **Raquel
Morera Sempere**, 30 Cattano Ave., Apt.
424, Morristown, NJ (US) 07960;
Stephanie Demers, 110 Barchester Way,
Westfield, NJ (US) 07090; **Bryan J.
Lyles**, 442 Route 202-206 North, #468,
Bedminster, NJ (US) 07923; **James
Alfieri**, 26 Midland Dr., Palmer
Township, PA (US) 18045

(56) **References Cited**
U.S. PATENT DOCUMENTS
6,662,017 B2 12/2003 McCann et al.

(Continued)

FOREIGN PATENT DOCUMENTS
WO 2006125085 A3 11/2006

OTHER PUBLICATIONS

Appiah, Charles N.; PCT Search Report; Jul. 2008.

Primary Examiner—Charles N Appiah

Assistant Examiner—Michael T Vu

(74) *Attorney, Agent, or Firm*—Fitch Even Tabin & Flannery

(*) Notice: Subject to any disclaimer, the term of this
patent is extended or adjusted under 35
U.S.C. 154(b) by 228 days.

(21) Appl. No.: **11/436,742**

(57) **ABSTRACT**

(22) Filed: **May 18, 2006**

(65) **Prior Publication Data**

US 2006/0276192 A1 Dec. 7, 2006

Related U.S. Application Data

(60) Provisional application No. 60/682,276, filed on May
18, 2005, provisional application No. 60/714,625,
filed on Sep. 7, 2005.

(51) **Int. Cl.**
H04Q 7/20 (2006.01)

(52) **U.S. Cl.** **455/436; 455/445; 455/456.5;**
370/331

In a telecommunications network in which a mobile handset is capable of communicating in both an IP domain and a non-IP domain, the handoff of an existing communications session between the mobile handset and a fixed user is facilitated by a handoff controller implemented in a service control point. The handoff controller implements different handoff methods depending on the status of the fixed user and the transition of the mobile user. Additionally 802.21 Media Independent Handover Function in conjunction with SIP is used to facilitate handover between IP and Non-IP points in the system.

28 Claims, 19 Drawing Sheets

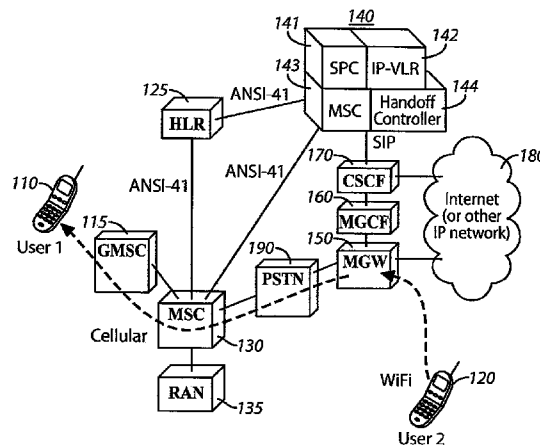

US 7,664,501 B2

Page 2

U.S. PATENT DOCUMENTS								
6,944,150	B1 *	9/2005	McConnell et al.	370/352	2006/0046714	A1 *	3/2006 Kalavade	455/428
6,999,770	B2 *	2/2006	Hirsbrunner et al.	455/445	2006/0116127	A1 *	6/2006 Wilhoite et al.	455/442
7,031,280	B2 *	4/2006	Segal	370/331	2006/0121916	A1 *	6/2006 Aborn et al.	455/456.5

* cited by examiner

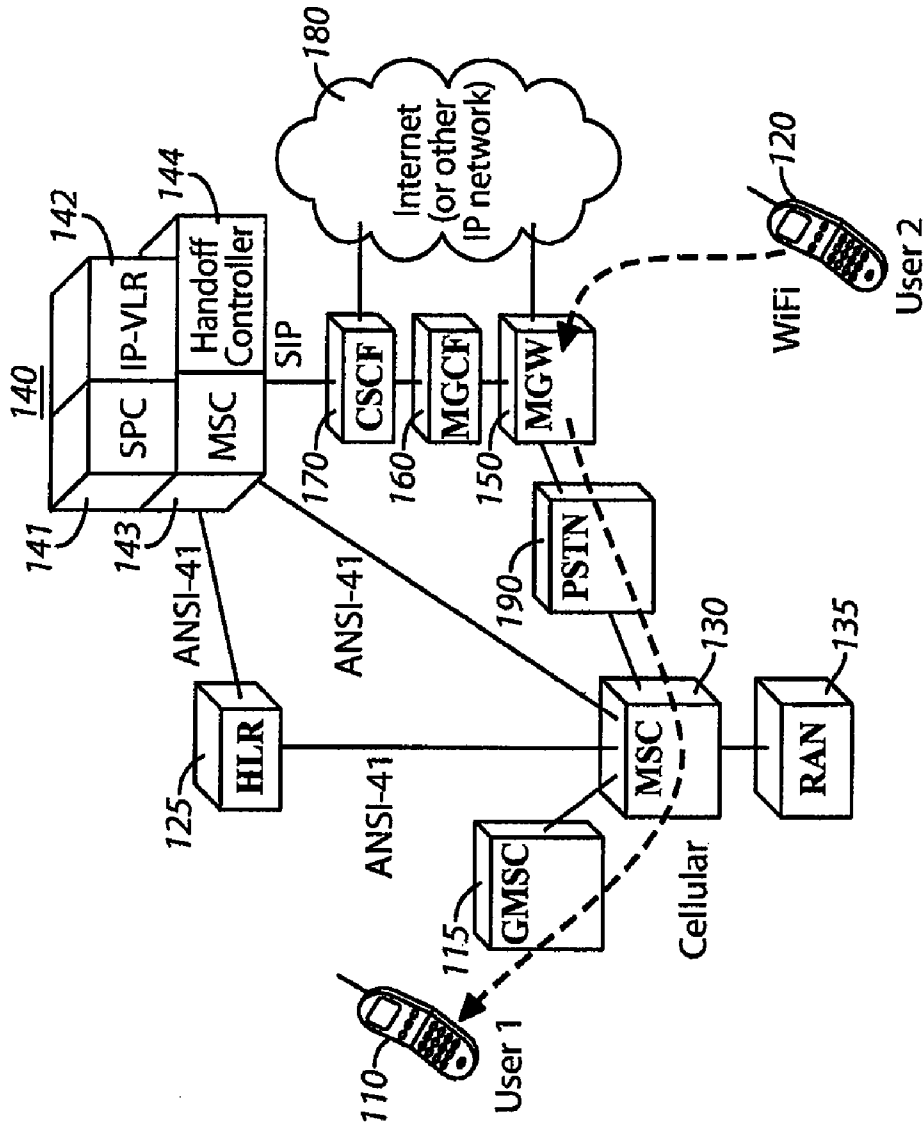

FIG. 1

Scenario	Fixed User	Handoff	Handback
1	IP	IP → CDMA	CDMA → IP
2	IP	CDMA → IP	IP → CDMA
3	CDMA/PSTN	CDMA → IP	IP → CDMA
4	CDMA/PSTN	IP → CDMA	CDMA → IP

210
220
230
240

FIG. 2

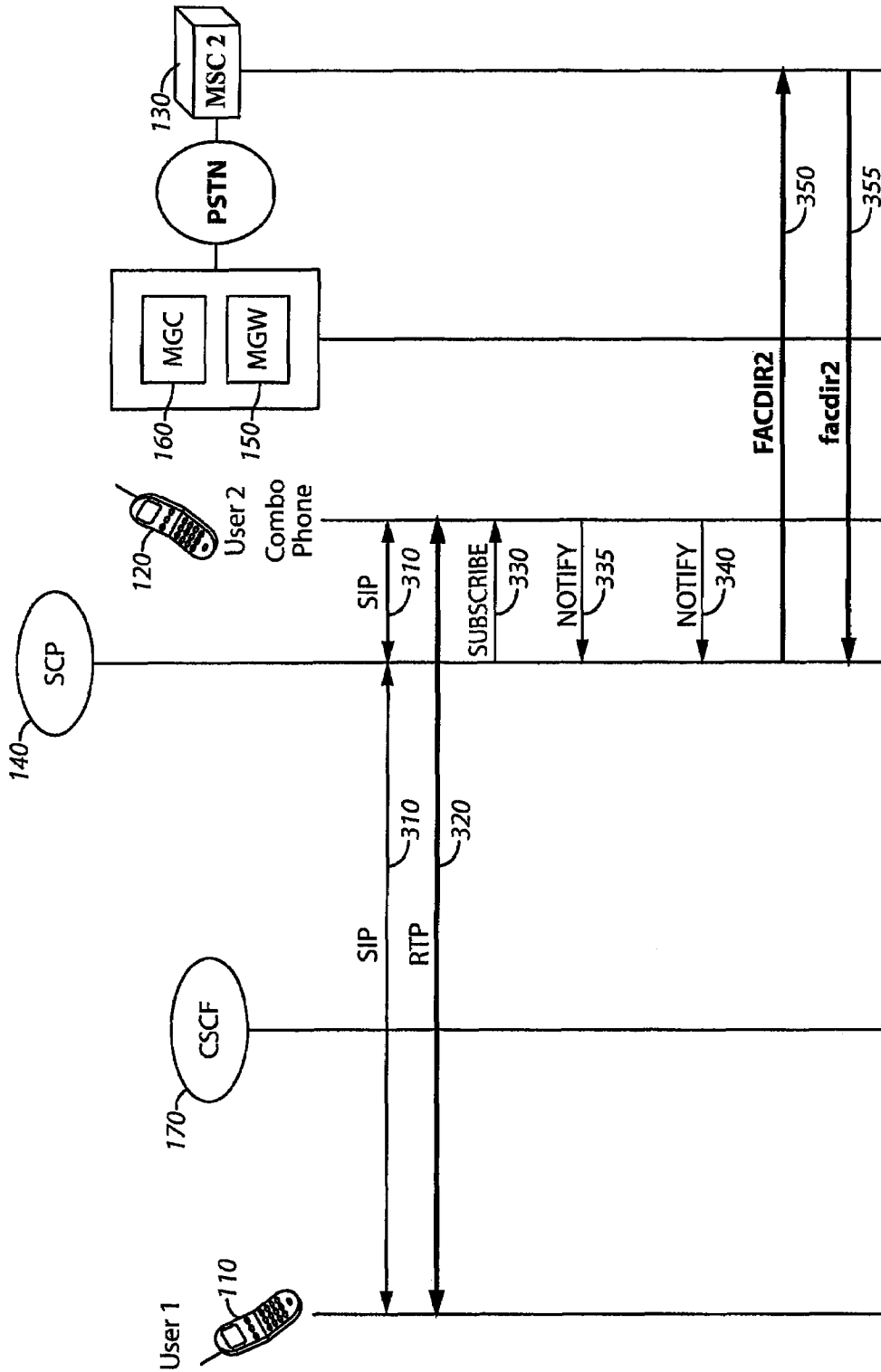

FIG. 3A

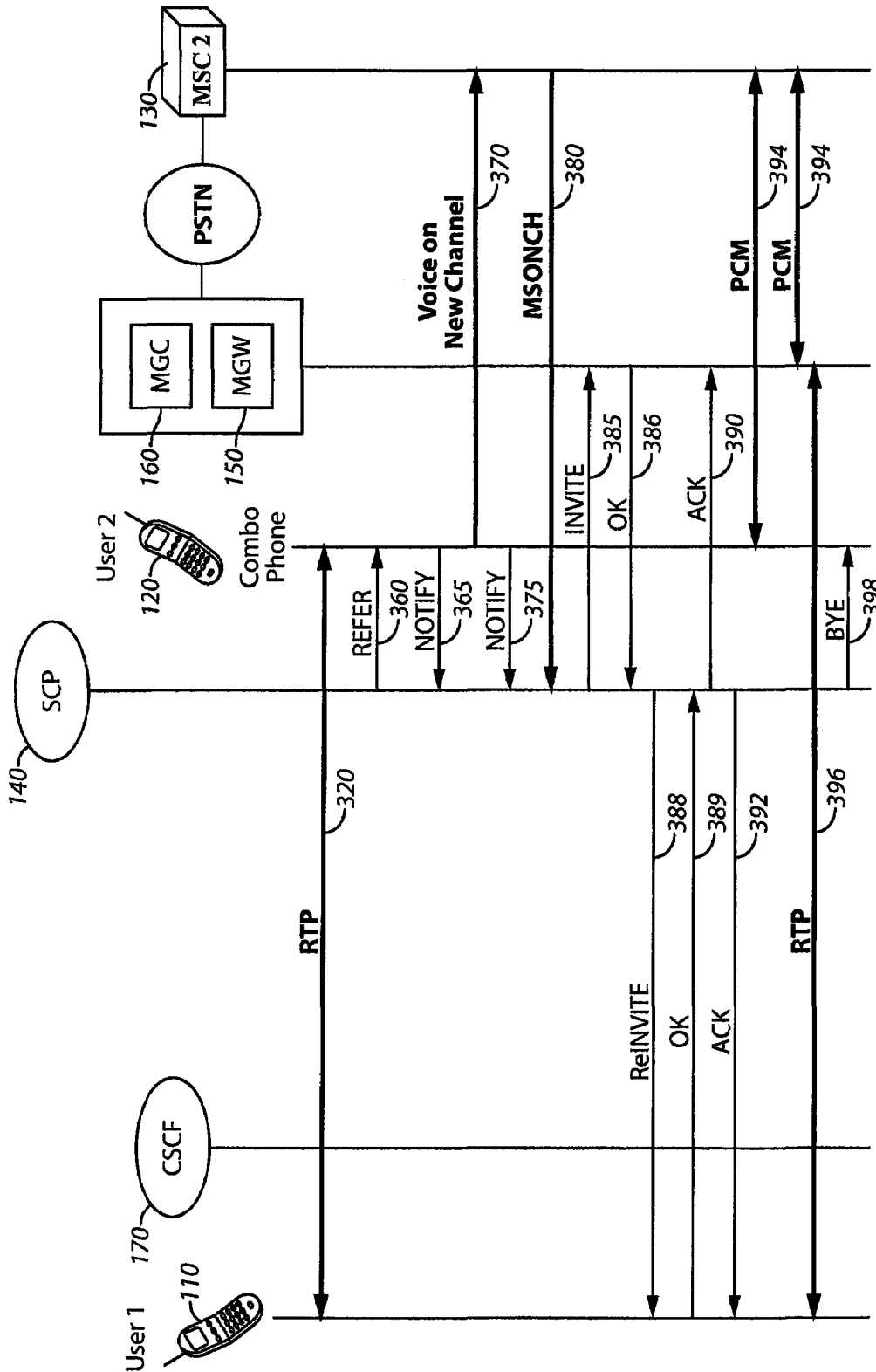

FIG. 3B

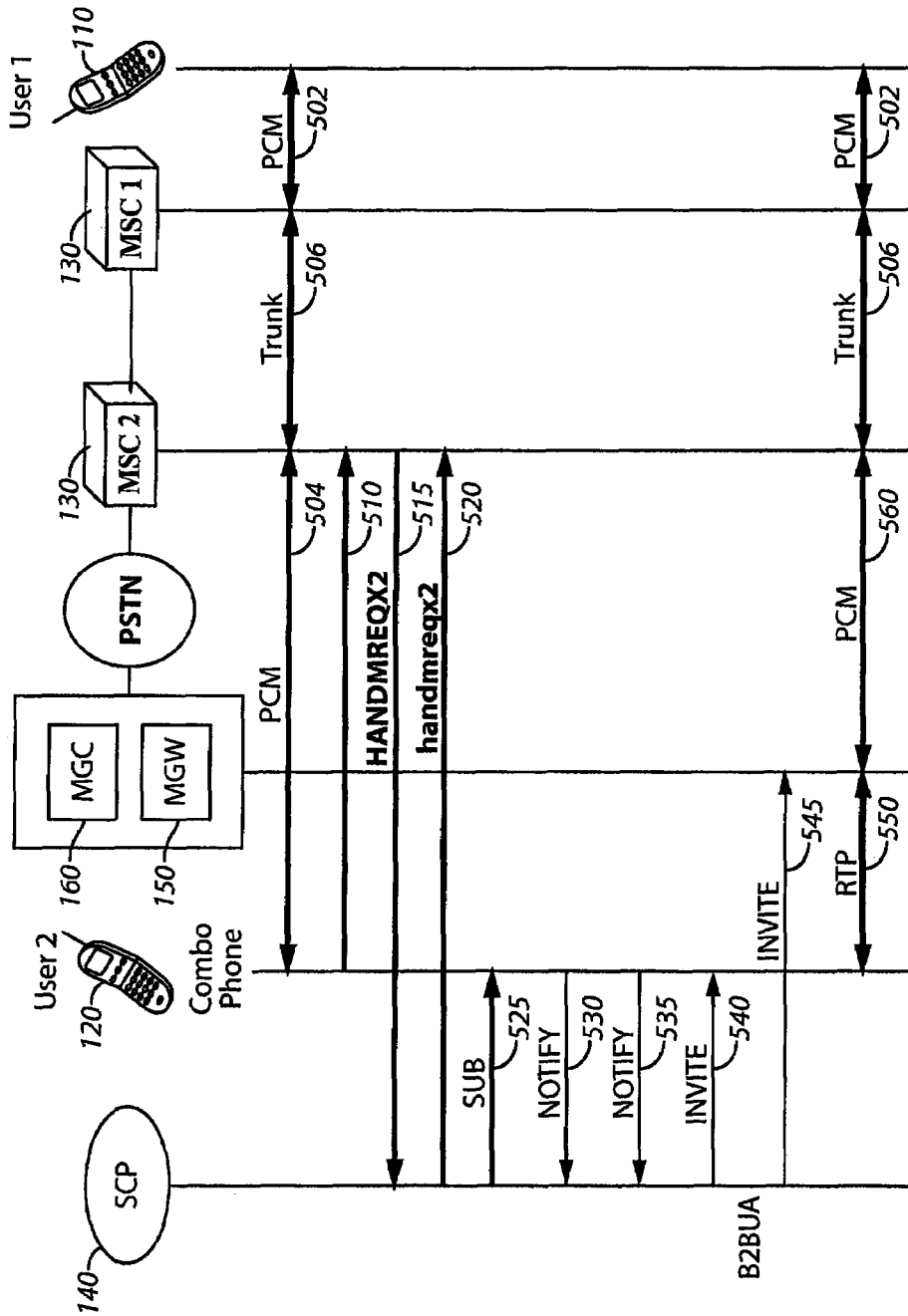

FIG. 5

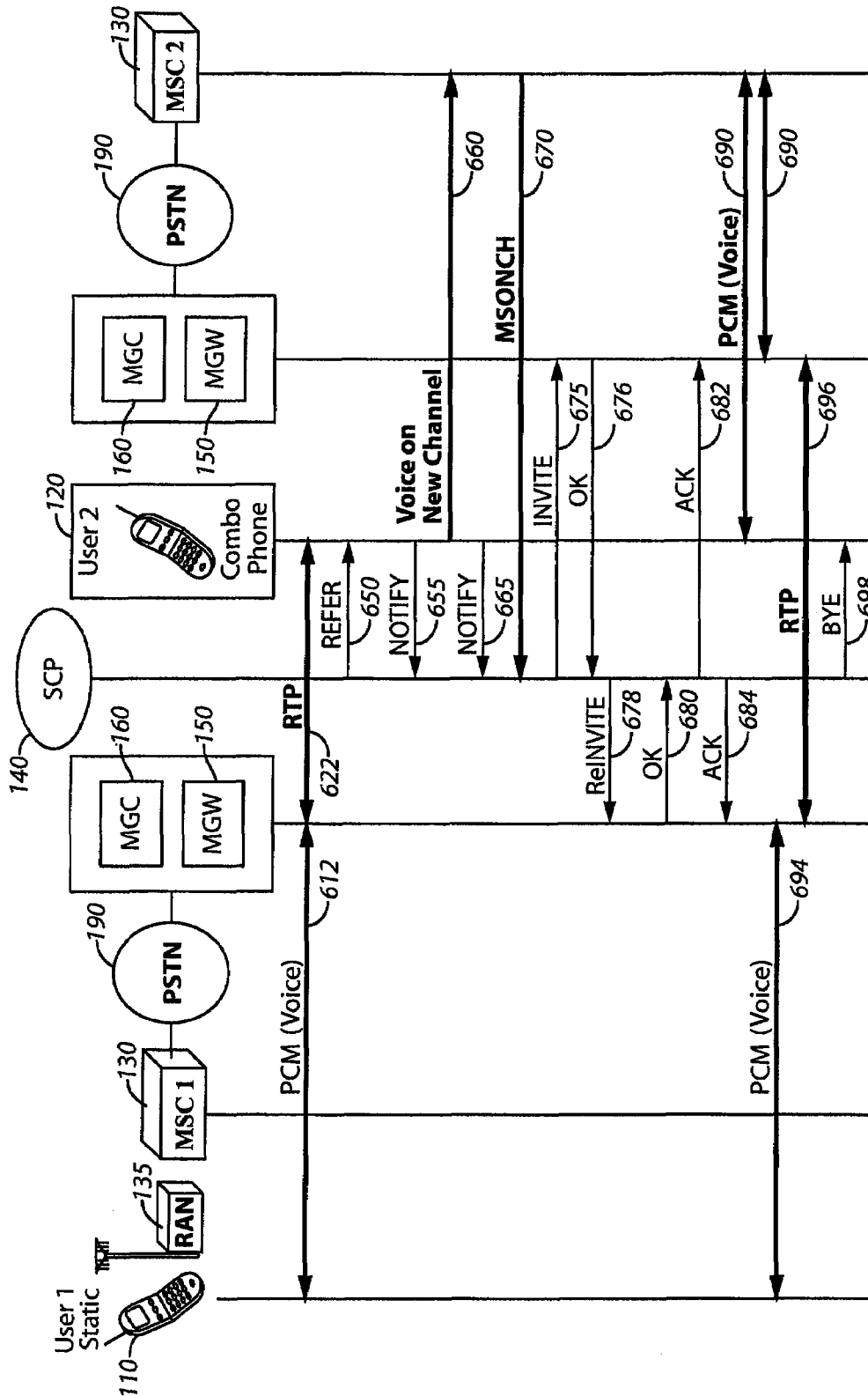

FIG. 6B

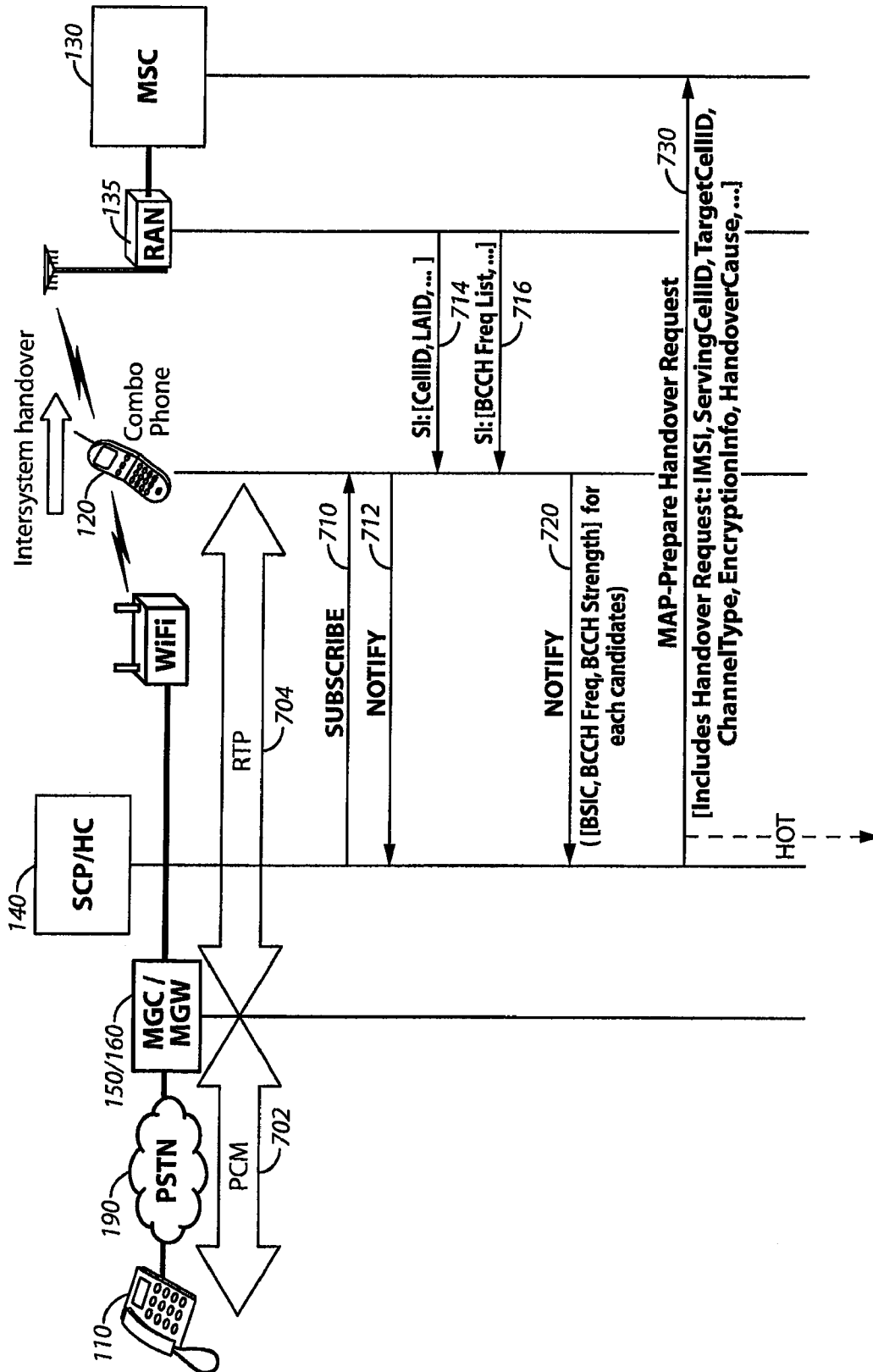

FIG. 7A

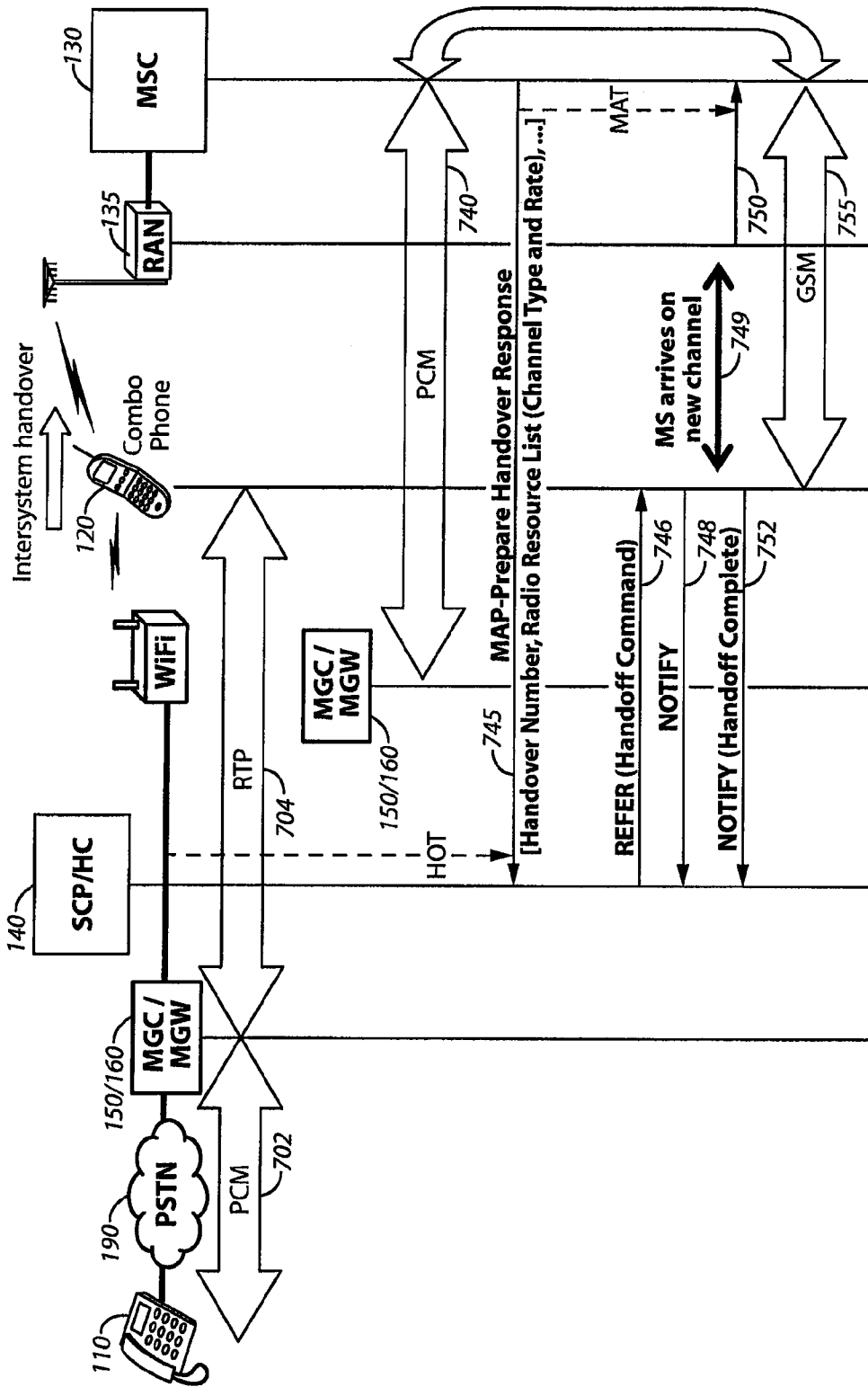

FIG. 7B

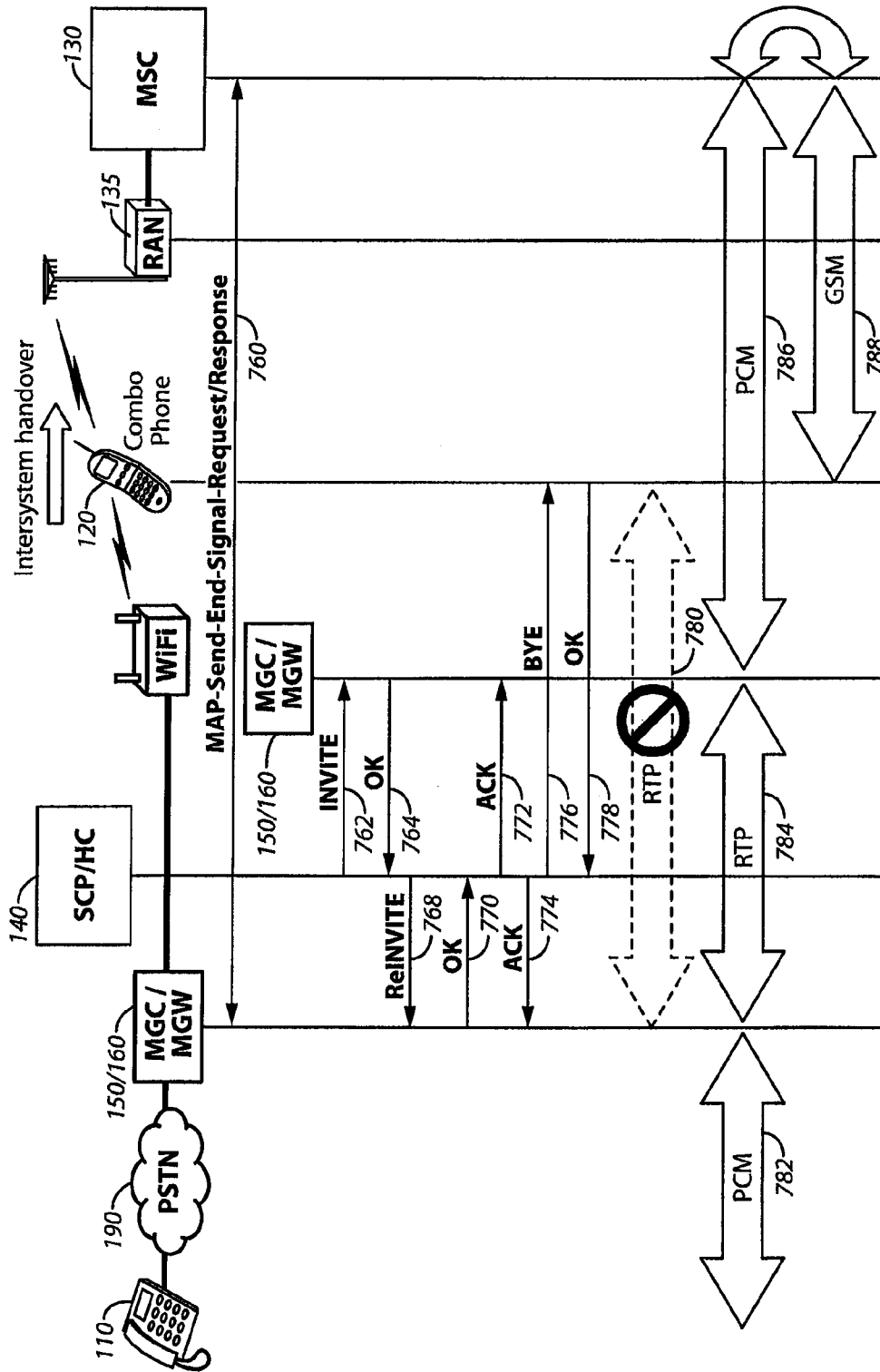

FIG. 7C

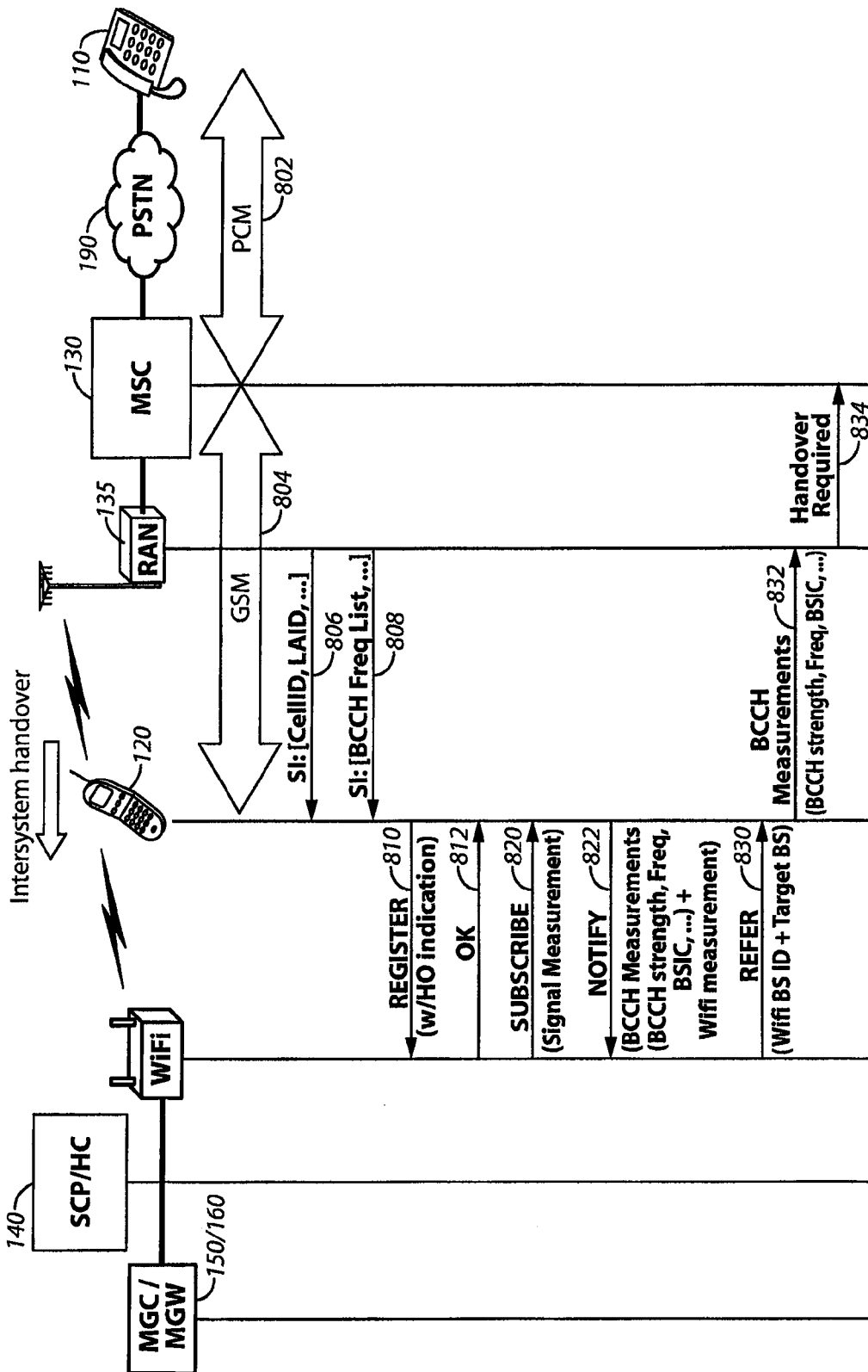

FIG. 8A

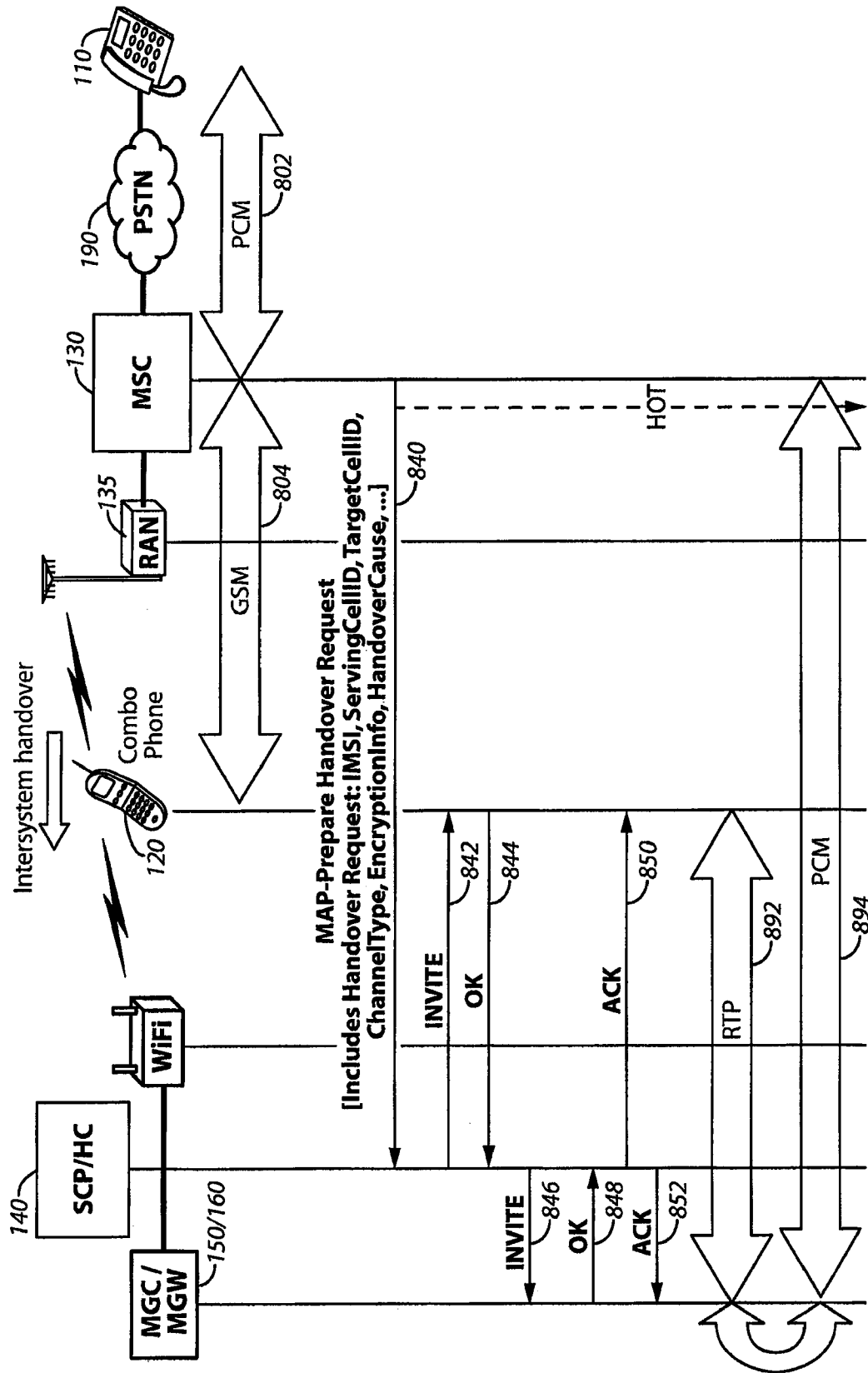

FIG. 8B

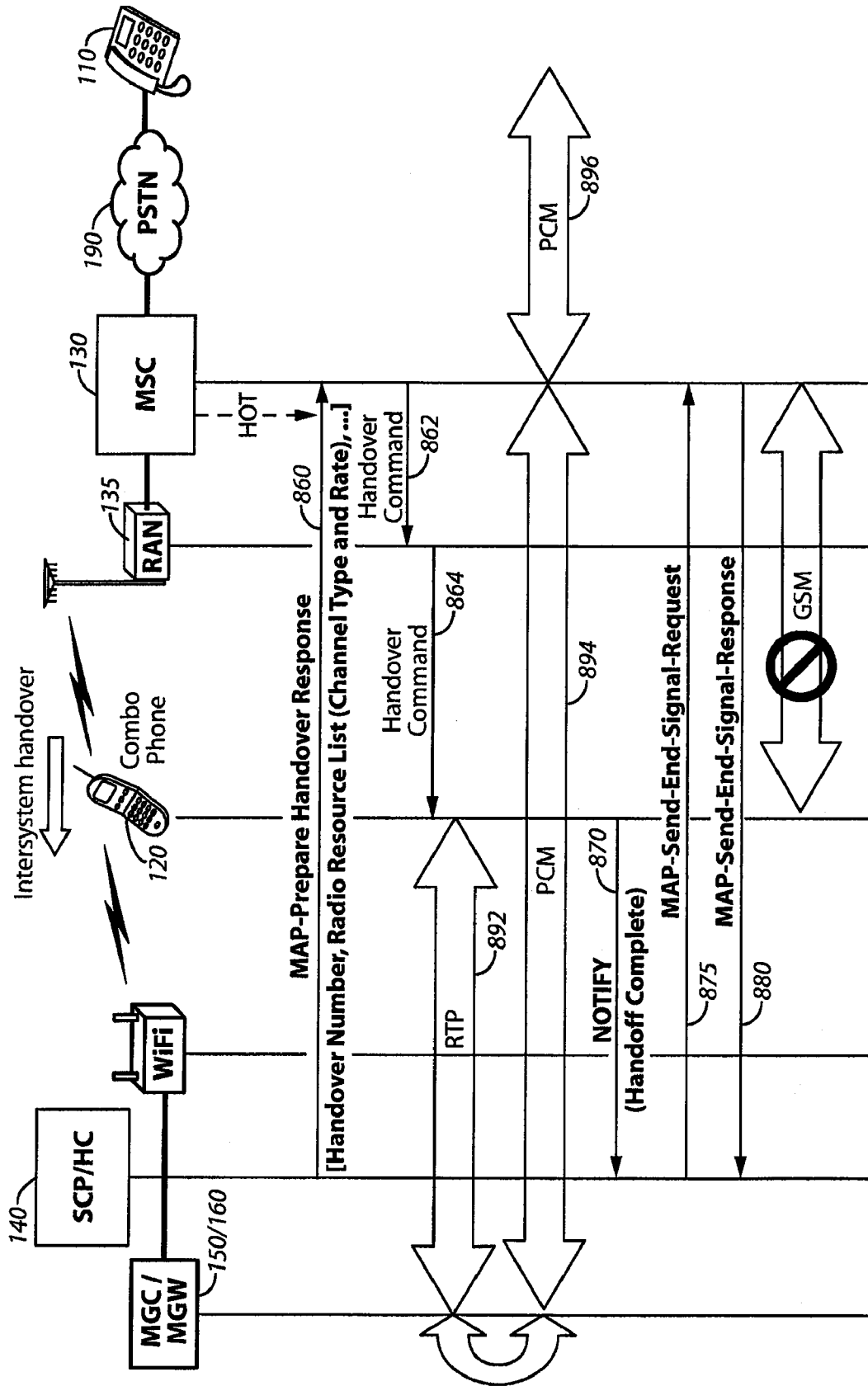

FIG. 8C

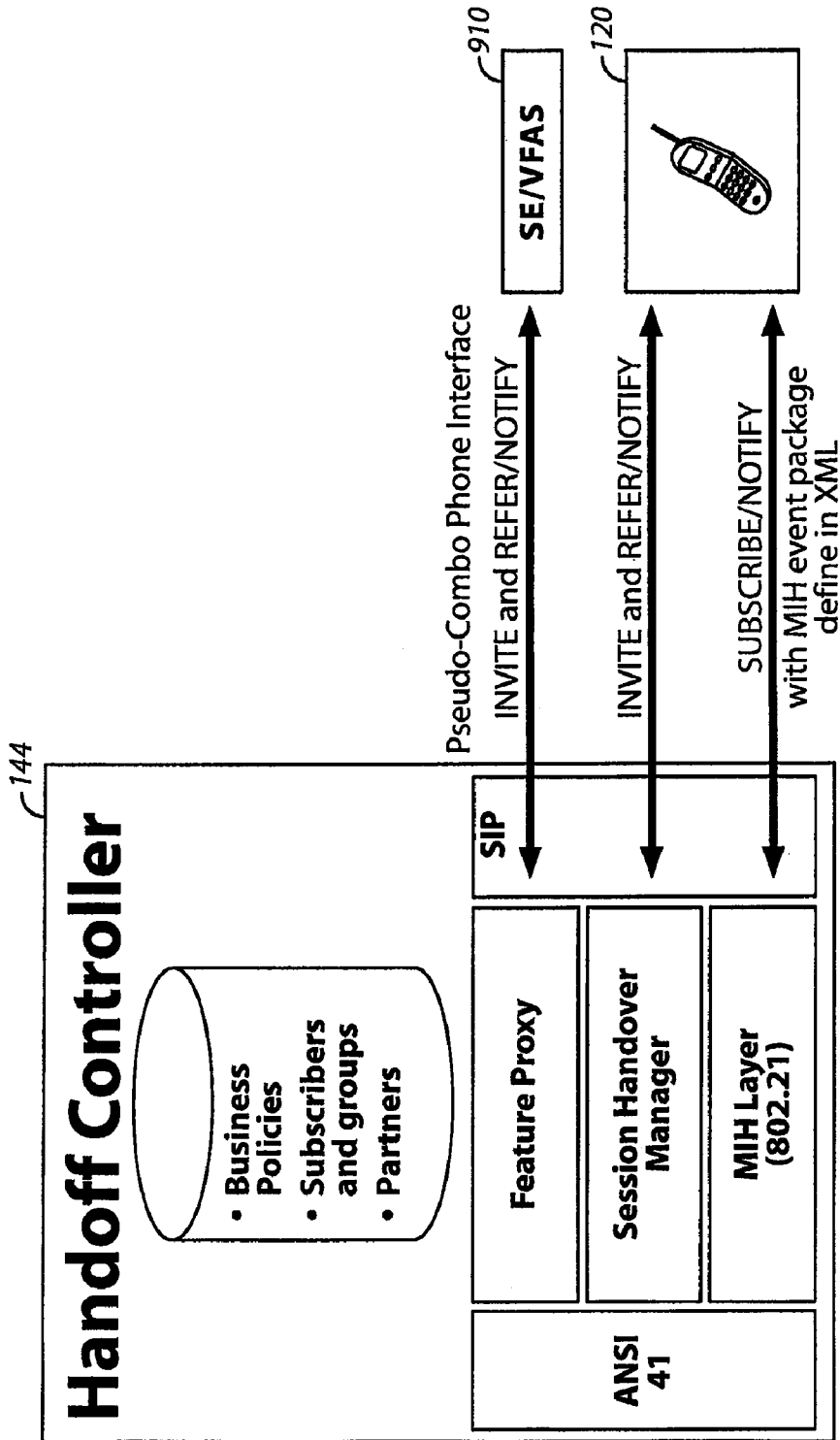

FIG. 9

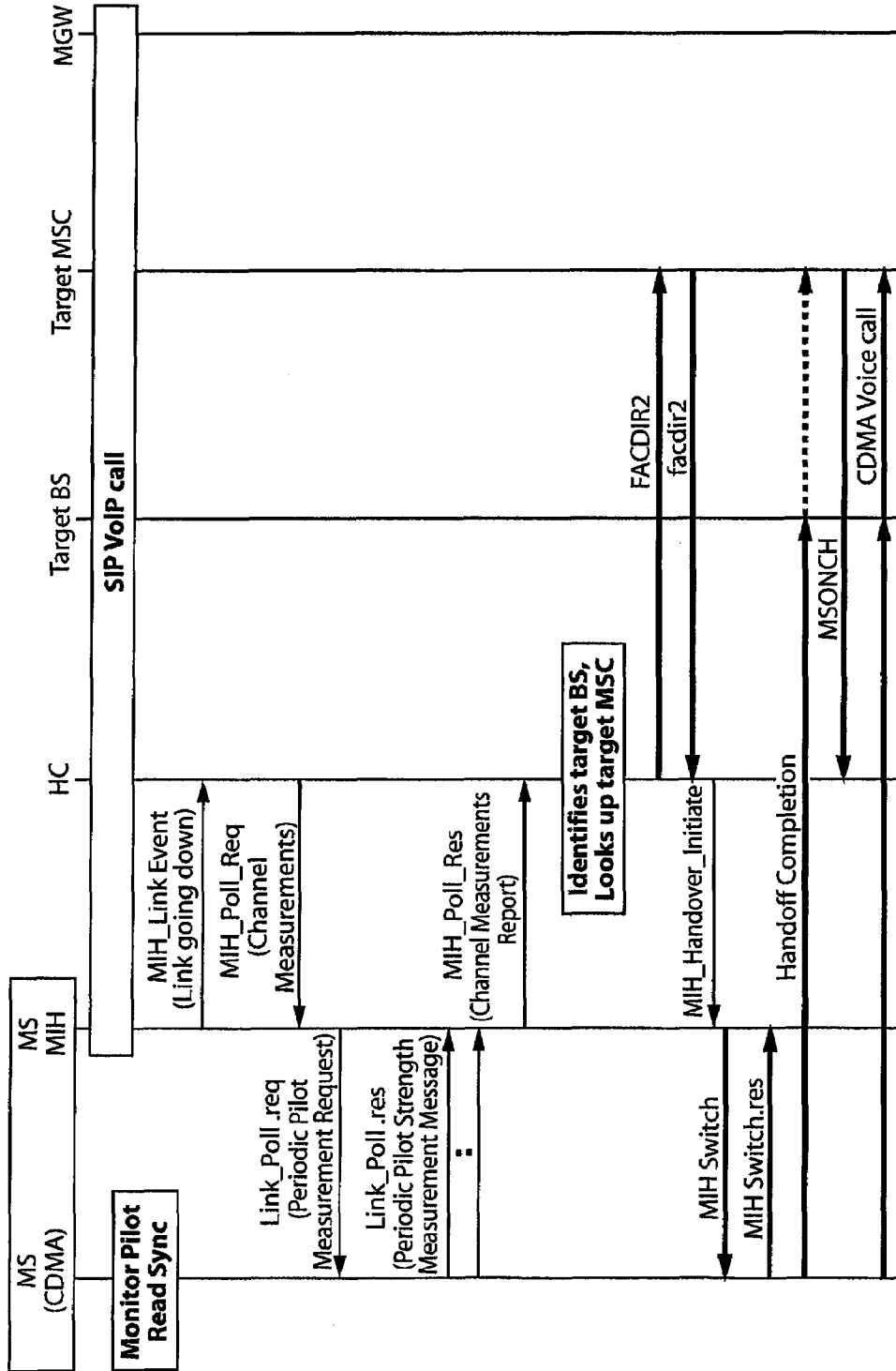

FIG. 10

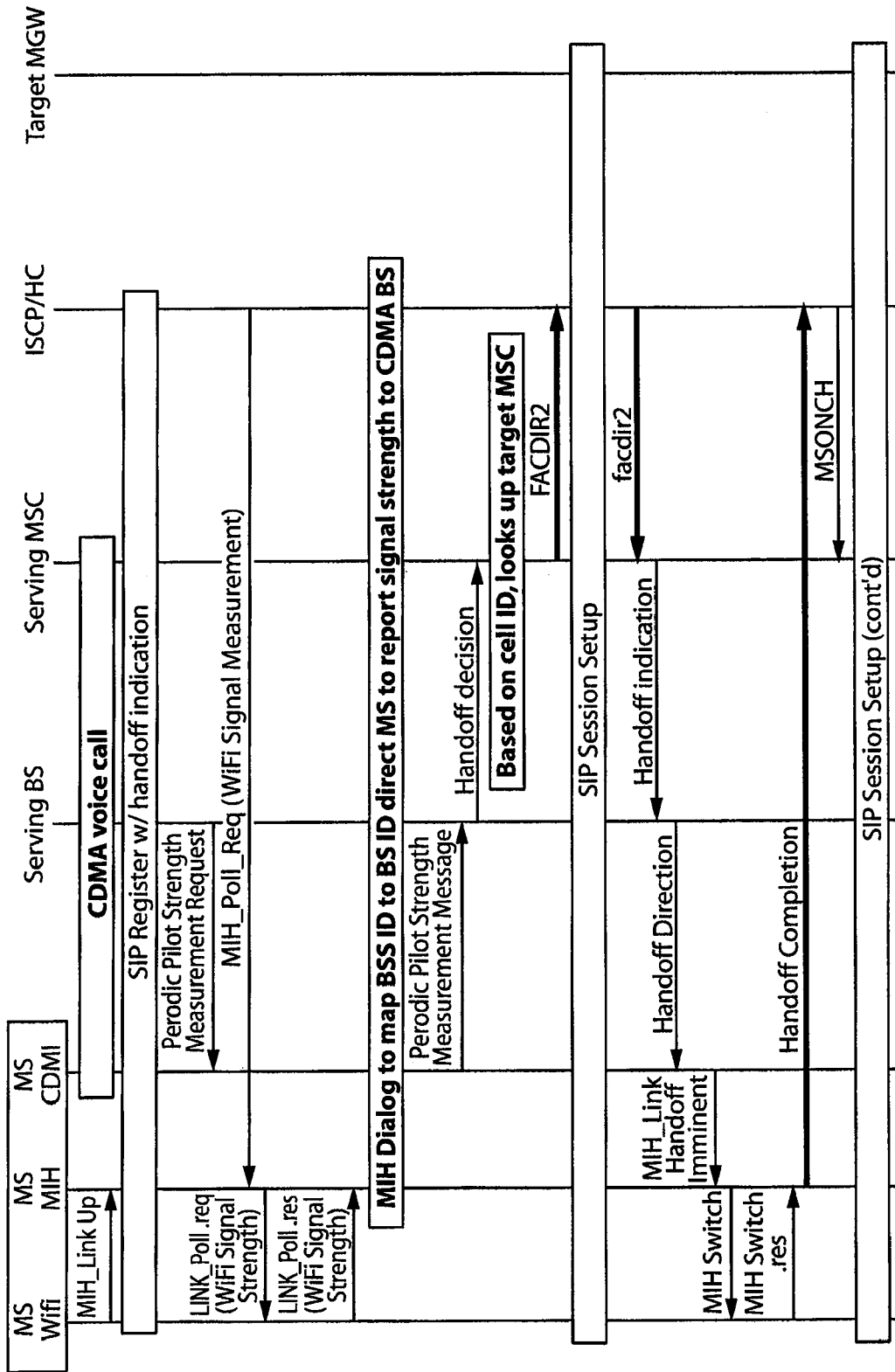

FIG. 11

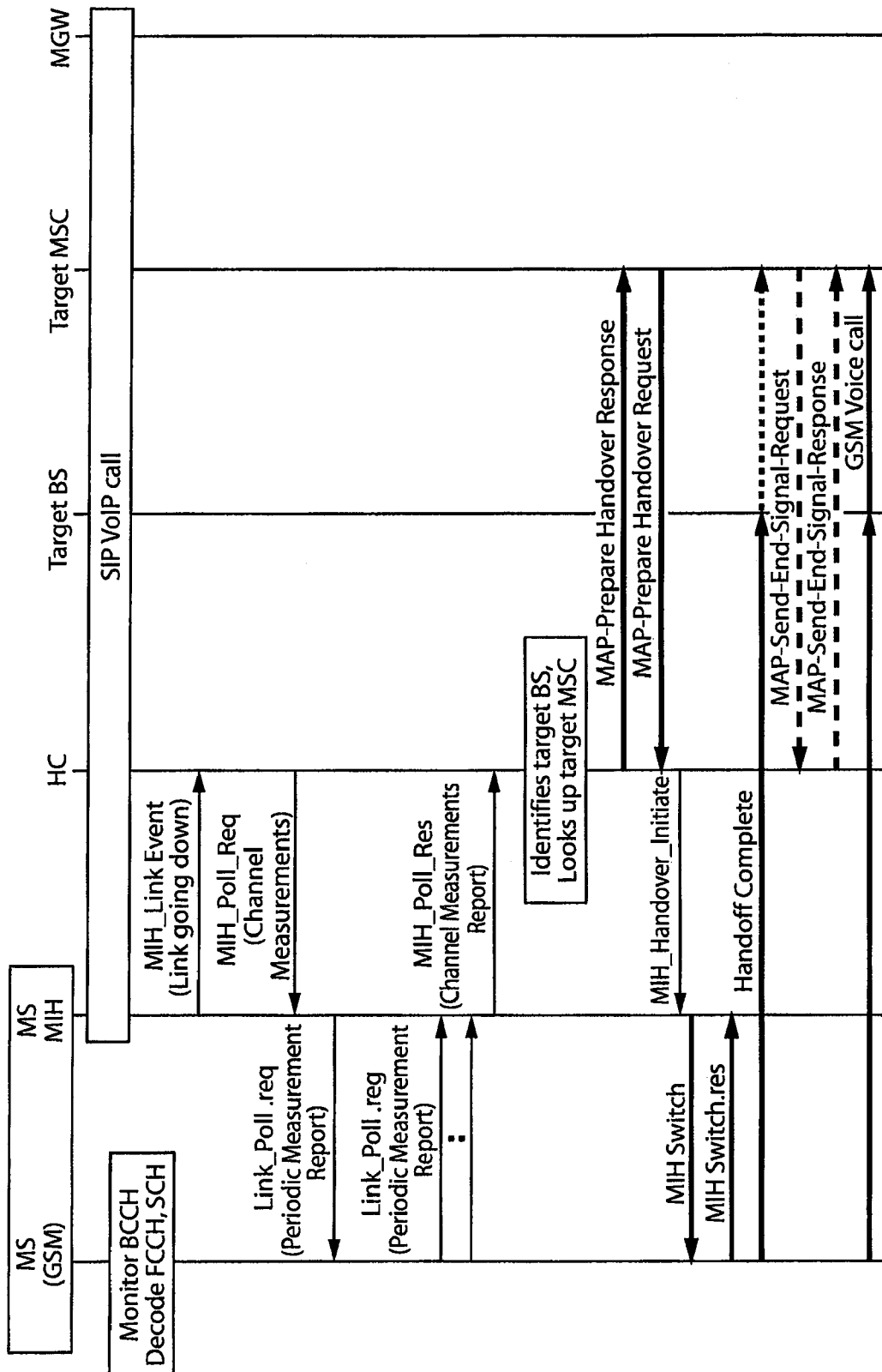

FIG. 12

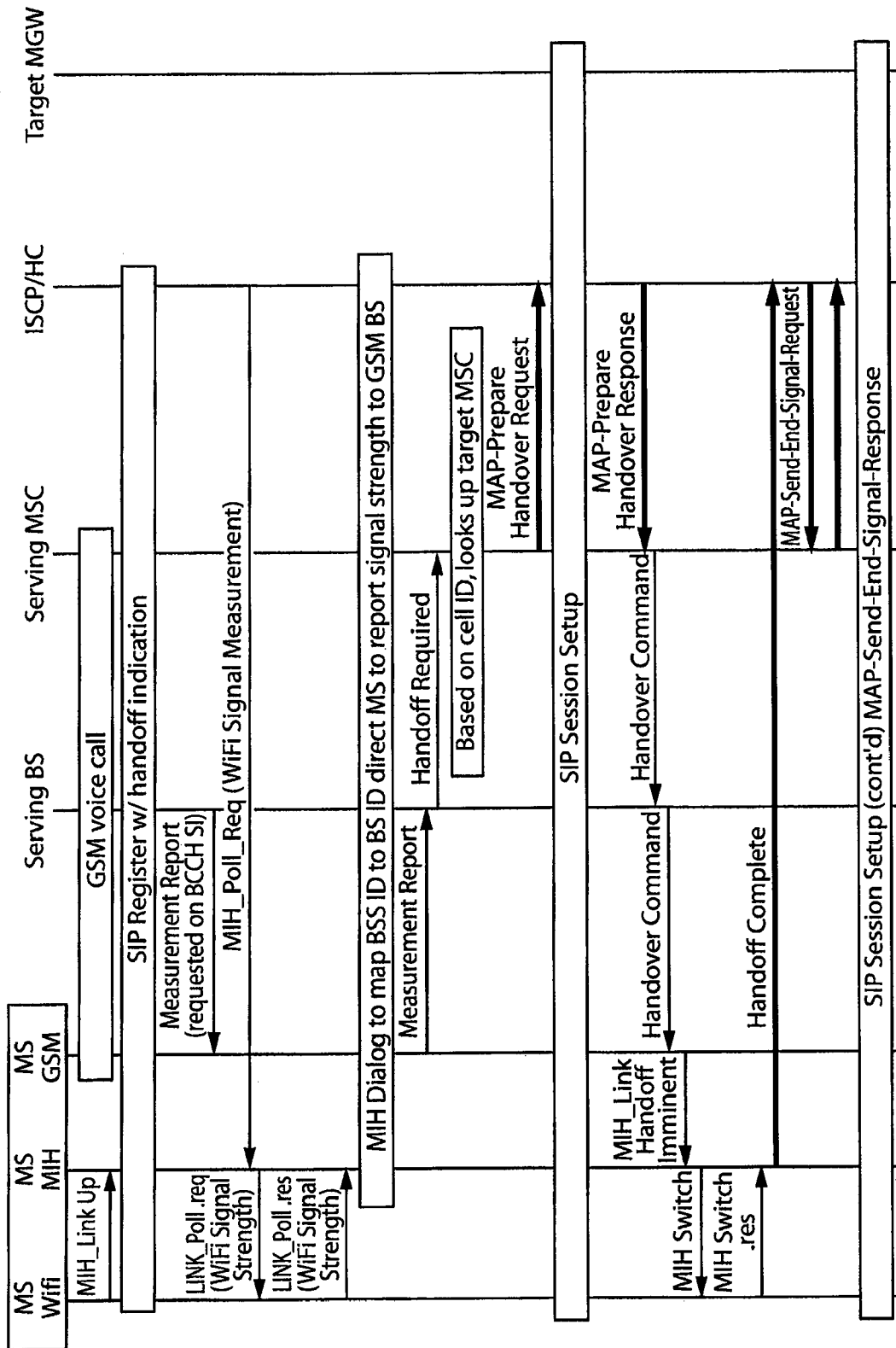

FIG. 13

**SEAMLESS HANDOFF ACROSS
HETEROGENEOUS ACCESS NETWORKS
USING A HANDOFF CONTROLLER IN A
SERVICE CONTROL POINT**

CROSS-REFERENCE TO RELATED
APPLICATIONS

This application claims the benefit of U.S. Provisional Patent Application No. 60/682,276 filed on May 18, 2005 and U.S. Provisional Patent Application No. 60/714,625, filed on Sep. 7, 2005, the disclosures of which are hereby incorporated herein by reference.

FIELD OF THE INVENTION

This invention relates generally to the handoff of a communication session with a mobile user as the mobile user moves from one type of access network to another, such as moving from a Wireless Fidelity (WiFi) or WiMAX network to a standard mobile cellular network such as CDMA or GSM networks. More specifically, this invention relates to a method and mechanism using a service control point ("SCP") implementing a handover controller in order to provide seamless handoff to a mobile user using a "combo-phone" (e.g., a phone capable of operating in both a WiFi or WIMAX network and a CDMA or GSM network) as the user moves across such heterogeneous access networks in both the Internet Protocol ("IP") and non-IP domains.

BACKGROUND OF THE INVENTION

A number of different mobile access networks have been developed and are deployed around the world. Around the world, the primary mobile access networks for cellular telephony are based on one of two families of standard communications protocols: Code Division Multiple Access ("CDMA") and Global System for Mobile Communications ("GSM"). Cellular networks operating in one of these two standards provide telecommunication services to the users of mobile handsets or "cell-phones" in most countries in the world. Cellphones that operate on one or both of these types of networks are well-know in the art.

WiFi is another type of mobile access network that has been implemented in the IP domain. In WiFi networks, access points or "hot-spots" provide user of mobile computers, PDA's and WiFi compatible telephony handsets with the ability to connect to the Internet and communicate with other users using data transfers such as e-mail or instant messaging ("IM") or voice over IP ("VoIP") protocols. WiFi began as a method and system for enabling users to create wireless local area networks ("wireless LAN") in order to wirelessly communicate with one another such as computers within a home or office. The most widely used wireless LAN technology is based on the IEEE 802.11 protocol which is known as WiFi. WiFi has increasingly become a method for mobile users to communicate with the Internet and make and receive VoIP calls. There are various versions of the IEEE 802.11 protocol in use, such as 802.11(a), 802.11(b) and 802.11(g). WiFi can transmit data up to approximately 320 feet indoors and 400 feet outdoors at speeds up to 54 million bits per second ("mbps").

Worldwide Interoperability for Microwave Access ("WiMax") is a more recent wireless LAN communication protocol known as 802.16. WiMax can transmit data up to approximately 70 mbps with a radius of approximately 30 miles. With such a communication radius a user could travel

a significant distance and remain within reach of the access point and far fewer nodes would be needed to provide mobile communications to a user over a large area.

Recently, it has been proposed to have mobile handsets or cellphones that can operate in both the traditional cellular networks based on the various CDMA and GSM standards while also enabling a user to communicate with the Internet and place VoIP calls through WiFi and/or WiMax access points. As ubiquitous access becomes more prevalent, a mobile user equipped with a terminal or handset with multi-mode capabilities can move between heterogeneous access networks such as Bluetooth, 802.11X, WiMax, CDMA1XRTT, IPv6 and cellular (CDMA, GSM) networks. As the mobile moves between networks, the signaling and radio access networks will be different in each access network. While there has been some prior work to take care of seamless handoff when a user moves between two IP networks with different access technologies, there has been little work on providing a seamless handoff when a mobile moves between IP and non-IP networks involving different radio access networks. For example a user may be equipped with a "combo-phone" that can be connected to both 802.11 type IP networks and non-IP cellular networks such as CDMA or GSM. Based on user's preference and position (e.g., at home or in the car), a combo-phone can actively communicate via either interface. However it is a key challenge to handover the existing session seamlessly from one interface to another interface as the mobile moves in and out of the network of a specific kind.

Different access technologies have different mechanisms to attach to each different access network. Each network needs certain specific ways to obtain network resources (e.g., configuration parameters) and it takes different amounts of time to provide such network resources. It is not always possible to pre-configure all network information. Security requirements such as authentication of users are different for different access networks. Intra-technology mobility management and/or roaming vary between access networks. Supporting seamless mobility between heterogeneous networks is a challenging task since each access network may have different mobility, Quality of Service (QoS) and security requirements. Moreover, interactive applications such as VoIP and streaming media have stringent performance requirements on end-to-end delay and packet loss. The handover process places additional stress on these performance criteria by introducing delays due to discovery, configuration and binding update procedures associated with mobility events. Performance can also be tied to the specific access networks and protocols that are used for network access. Movement between two different administrative domains raise additional challenges since a mobile handset will need to re-establish authentication and authorization in the new domain.

Currently there are several initiatives to optimize mobility across heterogeneous networks. The MOBOPTS working group within the Internet Research Task Force (IRTF) and the Detecting Network Attachment (DNA) group within the Internet Engineering Task Force (IETF) are investing ways to support handover by using appropriate triggers from the lower layers. These initiatives deal only with issues of mobility between IP networks and do not provide solutions for mobility between heterogeneous (e.g., IP and Non-IP) networks.

The IEEE 802.21 working group has created a framework that defines a Media Independent Handover Function (MIHF) to facilitate the handover across heterogeneous access networks and help mobile users to experience better perfor-

mance during seamless handover. This MIHF provides assistance to underlying mobility management approaches by allowing information about neighboring networks, link specific events and commands that are necessary during the handover process. The goal of IEEE 802.21 is to facilitate mobility management protocols such that the following handover requirements are fulfilled. One goal of IEEE 802.21 is to provide service continuity thereby minimizing the data loss and break time without user intervention. IEEE 802.21 supports applications of different tolerance characteristics. IEEE 802.21 provides a means of obtaining QoS information of the neighboring network. IEEE 802.21 provides a means of network discovery and selection. Network information could include information such as link type, link identifier, link availability, link quality. Selection of an appropriate handoff network can be based on required QoS, cost, user preference, etc. Power management can be accomplished by providing real-time link status. IEEE 802.21 does not provide a complete handover solution, but rather, is only a means to assist handover implementations.

The MIHF of 802.21 provides abstracted services to higher layers by means of a unified interface. This unified interface exposes service primitives that are independent of the access technology. The MIHF can communicate with access specific lower layer Media Access Control ("MAC") and Physical Layer ("PHY") components including those using IEEE 802.16, 802.11 and cellular protocols. The MIHF defines three different services: Media Independent Event Service (MIES), Media Independent Command Service (MICS) and Media Independent Information Service (MIIS).

Media Independent Event Service provides services to the upper layers by reporting both local and remote events. Local events take place within a client whereas remote events take place in the network. The event model works according to a subscription and notification procedure. An MIH user (typically upper layer protocols) registers to the lower layers for a certain set of events and is notified as those events take place. In the case of local events, information propagates upward from the MAC layer to the MIH layer and then to the upper layers. In the case of remote events, information may propagate from the MIH or Layer 3 Mobility Protocol (L3MP) in one stack to the MIH or L3MP in a remote stack. Some of the common events defined include "Link Up", "Link Down", "Link Parameters Change", "Link Going Down", "L2 Handover Imminent" among others. As the upper layer is notified about certain events it makes use of the command service to control links to switch over to a new point of attachment.

Media Independent Command Service (MICS) provides higher layers with MICS primitives to control the function of the lower layers. MICS commands are used to gather information about the status of the links, as well as to execute higher layer mobility and connectivity decisions from the lower layers. MIH commands can be both local and remote. Some examples of MICS commands are MIH Poll, MIH Scan, MIH Configure and MIH Switch. The commands instruct an MIH device to poll connected links to learn their most recent status, to scan for newly discovered links, to configure new links and to switch between available links.

Media Independent Information Service defines information elements and corresponding query-response mechanism to allow an MIHF entity to discover and obtain information relating to nearby networks. The MIIS provides access to both static and dynamic information, including the names and providers of neighboring networks as well as channel information, MAC addresses, security information and other information about higher layer services helpful to handover decisions. This information can be made available via both

lower and upper layers. In some cases certain layer 2 information may not be available or sufficient to make intelligent handover decisions. In such scenarios, higher-layer services may be consulted to assist in the mobility decision-making process. The MIIS specifies a common way of representing information by using standard formats such as XML (external markup Language) and TLV (Type-Length-Value). Having a higher layer mechanism to obtain the information about the neighboring networks of different access technologies alleviates the need for a specific access-dependent discovery method.

It is, therefore, desirable to provide a method and mechanism for providing a seamless handoff when a mobile user using a mobile handset moves from an IP network such as a WiFi network to a non-IP cellular network such as a CDMA or GSM network, or vice versa.

It is desirable to address the issues of differing attachment mechanisms, allocation of network resources, timing, security and roaming when a mobile user transfers from using an IP network to a non-IP network or vice versa thereby avoiding packet loss.

It is desirable to take advantage of the MIHF of the emerging IEEE 802.21 standard in order to implement seamless handoff between heterogeneous networks.

SUMMARY OF THE INVENTION

This present invention has come up with solution for seamless mobility in four different scenarios. These scenarios are based on the type of movement of the user and the position of the corresponding user the mobile is communicating with. In contrast to prior art solutions that handle handoffs between IP networks, handoffs between IP and non-IP (cellular) networks involve more complex flows, involve more interaction between networking elements and require different handoff algorithms. The present invention proposes flows involving Session Initiation Protocol ("SIP") to ANSI-41 and SIP to GSM mappings that will help provide the seamless handoff. Although applied explicitly herein as using WiFi to be the RAN (Radio Access Network) for IP networks, the RAN can always be other broadband connection such as WiMAX. The method also proposes the use of primitives defined in the 802.21 standards to take care of handoff between IP and Non-IP networks, while 802.21 standards do not mandate this type of handoff. The present method is mobile assisted but network controlled. A mobile handset that is likely to move can send the handover imminent signal to the SCP (Service Control Point) which, in turn, will control the handoff by setting up the communication between other networking elements in the network such as serving MSC (Mobile Switching Center) and target MSC. A combination of the SCP 140 and the Media Gateway Control ("MGC") and Media Gateway ("MGW") is the "WiFi MSC" that can act like a serving MSC or target MSC based on the mobile's movement pattern (i.e., IP to Cell or Cell to IP). Certain ANSI-41 or GSM-related information is carried as part of SIP signaling. Standard SIP messages such as REFER, INVITE, SUBSCRIBE, NOTIFY, a SIP Proxy, and B2BUA are used. These messages carry the information related to IEEE 802.21 primitives, ANSI-41 and GSM-related information in the body of these messages. The event notification package between the mobile and the SCP 140 are taken advantage of to assist the handoff from an IP network to a cellular network, and vice versa.

A method for using a handoff controller in the network for handing off a communication session of a mobile user from a first network to and a second network wherein the first network is either an IP network or a cellular network and the

5

second network is the respective other type and wherein a mobile handset operated by the mobile user is in communication with a handset operated by a fixed user is provided. The handoff controller sends messages to the mobile handset instructing the mobile handset to monitor one or more predetermined characteristics of the air interface between the mobile user and the first network. The mobile handset responds to the handoff controller when one or more predetermined characteristics have been met. The handoff controller then collects information regarding the available connection points in the second network and determines the identification of a connection point in the second network. Messages are sent from the handoff controller to the mobile handset identifying the connection point in the second network and a communication session between the mobile user of the mobile handset in the second network is established (the mobile user of the mobile handset and the fixed user). The handoff controller can reside in the SCP.

BRIEF DESCRIPTION OF THE DRAWING

FIG. 1 depicts the network architecture of a telecommunication system in which the present invention is implemented.

FIG. 2 is a diagram depicting the various handover scenarios.

FIGS. 3A and 3B are diagrams depicting handoff flow in scenario 1 wherein the fixed user is in the IP domain and the mobile user transitions from the IP domain to the cellular domain.

FIG. 4 is a diagram depicting handoff flow in scenario 2 wherein the fixed user is in the IP domain and the mobile user transitions from the cellular domain to the IP domain.

FIG. 5 is a diagram depicting handoff flow in scenario 3 wherein the fixed user is in the cellular domain and the mobile user transitions from the cellular domain to the IP domain.

FIGS. 6A and 6B are diagrams depicting handoff flow in scenario 4 wherein the fixed user is in the cellular domain and the mobile user transitions from the IP domain to the cellular domain.

FIGS. 7A-C are diagrams depicting handoff flow wherein the mobile handset transitions from the IP domain to a GSM-based cellular domain while the other user remains fixed.

FIGS. 8A-C are diagrams depicting handoff flow wherein the mobile handset transitions from a GSM-based cellular domain to an IP domain while the other user remains fixed.

FIG. 9 is a functional diagram of the handoff controller and the SIP interface to the combo-phone mobile handset.

FIG. 10 is a diagram depicting the use of 802.21 primitives in the transition from the IP domain to the CDMA cellular domain.

FIG. 11 is a diagram depicting the use of 802.21 primitives in the transition from the CDMA cellular domain to the IP domain.

FIG. 12 is a diagram depicting the use of 802.21 primitives in the transition from the IP domain to the GSM cellular domain.

FIG. 13 is a diagram depicting the use of 802.21 primitives in the transition from the GSM cellular domain to the IP domain.

DETAILED DESCRIPTION OF THE INVENTION

FIG. 1 depicts the architecture of a telecommunication system for use in accordance with the method of the present invention. User 1 is referred to as the "fixed" or "static" user, i.e., the user that is not currently transitioning from an IP to a non-IP network. User 1 could be connected to the network via

6

a wireline or wireless connection in either the IP domain (i.e., DSL, WiFi, WiMAX, Cable modem) or non-IP domain (i.e., PSTN, CDMA cellular, GSM cellular etc.). User 1 may be connected via a Mobile Switching Center ("MSC") which could be connected to a Gateway MSC ("GMSC") 115. Radio Access Networks 135 are also part of the cellular network providing the final wireless link between and MSC 130 and the handset 110 used by User 1. User 2 is the mobile user that will be transitioning between IP and non-IP networks in the examples below. User 2 and associated mobile handset 120, also referred to as a "combo-phone," may be connected via an IP connection such as WiFi, WiMAX or other wireless IP protocol. Additionally the combo-phone also has an interface that can be used to connect to a CDMA or GSM network. The combo-phone thus has the ability to switch back and forth between cellular network and IP network. Such a connection would be routed through the Media Gateway ("MGW") 150 via the Public Switched Telephone Network ("PSTN") 190 to an MSC 130. Media Gateway Control Function ("MGCF" or "MGC") 160 is closely related to the Media Gateway and together provide the interface between IP and non-IP networks. Call Session Control Function ("CSCF") 170 is a well-known component of IP networks such as IMS (IP Multimedia Subsystem) of 3rd Generation Partnership Project ("3GPP") networks and its function remains unchanged in the present invention. Internet 180 is the ubiquitous packet switched network of routers or other similar IP network whether operating in IPv4, IPv6 or other protocol.

Service Control Point ("SCP") 140 is call control software and associated servers and other hardware that implements the following functions: SCP 140 implements the functionality of a standard Service Control Point 141 such as that provided by the Telcordia® SCP. Additionally, the SCP 140 includes a Handoff (or handover) Controller 144 which is further described below and in FIG. 9. SCP 140 also may include an Internet Protocol-Vesting Location Register ("IP-VLR") which is needed to maintain a record for IP mobility purposes. SCP 140 also contains a virtual MSC 143 which acts as a target or serving MSC in the various mobility scenarios described below. The MSC 143 is in communication with Home Location Register ("HLR") 125 which is in communication with actual MSC such as MSC 130.

Referring to FIG. 2, the present invention provides for a method and mechanism to provide seamless mobility in four different scenarios. These scenarios are based on the type of movement of the user and the position of the corresponding user with whom the mobile is communicating. In the first two scenarios the fixed user is operating in an IP network and may be connected via WiFi, WiMax, DSL, cable modem or some other type of IP access network and node. In the first scenario the mobile user is transitioning from being connected to an IP network to a cellular network ("Scenario 1") 210. In the second scenario the mobile user is moving from the CDMA domain to an IP domain ("Scenario 2") 220. In the other two scenarios the fixed user is connected to a cellular network such as a CDMA or GSM network or the PSTN. The fixed user may also be the mobile user in a future handoff and in a special scenario both users could be mobile. In scenario three the mobile user is moving from a cellular network to an IP network ("Scenario 3") 230. In scenario 4 the mobile user is moving from an IP network to a cellular while the fixed user is attached to a cellular network ("Scenario 4") 240. Each of the scenarios will now be described one at a time.

FIGS. 3A and 3B depict Scenario 1. In Scenario 1 the fixed user (User 1) and the mobile user (User 2) have initiated a standard Real-time Transport Protocol ("RTP") session using standard Session Initiation Protocol ("SIP") messaging at

step 310. User 1 and User 2 then communicate with one another using RTP at step 320. At step 330 SCP 140 sends a SIP SUBSCRIBE message to the mobile handset 120 of user 2 to prompt User 2 to notify the SCP 140 when a certain event occurs; for example, when the signal-to-noise ratio for the WiFi radio interface falls below a certain predetermined threshold number. Prior to the use of SIP SUBSCRIBE message here and elsewhere in this specification, the mobile handset has sent a SIP REGISTER message to the SCP 140 to make itself known to the SCP 140 and its current location. The use of these SIP REGISTER messages is not shown but is assumed in all appropriate cases. User 2 acknowledges the inquiry from the SCP 140 with a SIP NOTIFY message at step 335. When User 2 identifies that the predetermined event has occurred, User 2 sends a SIP NOTIFY message to SCP 140 at step 340. SCP 140 then selects the target MSC which will be used to service User 2. At step 350 the SCP 140 notifies the selected target MSC (“MSC 2”) using an ANSI-41 FACDIR2 message described in greater detail below. MSC 2 acknowledges the selection and includes channel information by returning a “facdir2” response message at step 355.

FIG. 3B depicts the continuation of the handoff process for Scenario 1. Existing RTP session 320 exists between User 1 and User 2. At step 360 SCP 140 sends a SIP REFER message to the mobile handset 120 used by User 2 which is the handoff order. The mobile handset used by User 2 acknowledges receipt of the handoff order by returning a SIP NOTIFY message to the SCP 140 at step 365. At step 370 the mobile handset 120 of User 2 sends an ANSI-41 “voice on new channel” message to the target MSC; i.e., MSC 2. At step 375 User 2 also sends a SIP NOTIFY message to SCP 140 notifying the SCP 140 that User 2 has alerted MSC 2 to the handoff. MSC 2 130 then sends an ANSI-41 MSONCH message to the SCP 140 at step 380. SCP 140 sends a SIP INVITE message to the MGW/MGC 150/160 at step 385 that requests permission to initiate an RTP session between User 1 and the MGW 150. At step 386 the MGW/MGC 150/160 returns a SIP OK message to the SCP 140 if it agrees to the session. At step 388, the SCP 140 sends a SIP ReINVITE message to User 1 to re-initiate the RTP session. User 1 sends a SIP OK message back to the SCP 140 at step 389. The SCP 140 then sends SIP ACK (“ACKNOWLEDGE”) message to both the MGW 150 and User 1 at steps 390 and 392 respectively, in order to complete the initiation of the RTP session between User 1 and the MGW 150. At step 394 User 2 now communicates with the MGW 150 through MSC 2 and the PSTN using Pulse Code Modulation (“PCM”). User 1 communicates with the MGW 150 through the SIP initiated RTP session at step 396. Thus, the transfer of User 2 from the original IP-based network in which it was communicating directly with User 1 in an RTP session to a cellular network in which it communicates with an CDMA-based MSC is complete. The SCP 140 then sends a SIP BYE message to User 2 and the handoff is complete.

Communication between User 1 and User 2 now occurs in the following manner. User 2 is in wireless communication with a base station (“BS”) forming part of a RAN connected to MSC 2 which is connected through the PSTN to the MGW 150. The MGW 150 is in an RTP session with User 1. MGW 150 is responsible for translating the RTP-based session into a PCM-based signal for transfer to User 2 and vice versa.

In Scenario 2 depicted in FIG. 4, User 1 remains in the IP domain connected to the Internet via a WiFi, WiMAX, DSL or other type of IP-based connection. User 2 is transferring from the cellular domain to the IP domain. The original call is set-up using a SIP initiated (step 402) RTP session (406) between the MGW 150 and User 1 and an ISUP initiated (step

404) PCM-based session (408) between User 2 and the MGW 150 through MSC 1 which is the serving MSC. MSC 1 sends an ANSI-41 HANDMREQX message to SCP 140 serving MSC 1 at step 410 in order to initiate the handoff. SCP 140 responds to MSC 1 with an ANSI-41 “handmreqx” message at step 415. MSC 1 selects the target MSC (i.e., the location of the Internet connection to which it will be connected) and notifies the SCP 140 of this through an ANSI-41 HANDBACK message at step 420. At step 425 the SCP 140 returns an ANSI-41 “handback” message to the MSC 1. At step 430 the SCP 140 sends a SIP SUBSCRIBE message to the mobile handset of User 2 in order to instruct the mobile handset to monitor the quality of its air interface with the RAN connected to the MSC. User 2 responds with a SIP NOTIFY message at step 435. The mobile handset of User 2 monitors the characteristics of the call and upon one or more parameters reaching a predetermined threshold, User 2 sends a SIP NOTIFY message to the SCP 140 at step 440. In response, the SCP sends a SIP INVITE message to User 2 at step 445 in order to initiate an RTP session between User 2 and User 1. User 2 responds with SIP OK message at step 450. At step 455 SCP 140 sends a SIP ReINVITE message to User 1 and User 1 responds with a SIP OK message at step 460. At step 470 the RTP session between User 1 and User 2 has been established. At step 480 the SCP sends a SIP BYE message to the MGW 150 notifying the MGW that the handoff has been completed and the MGW 150 can release the call session.

Referring to FIG. 5, the handoff flow for Scenario 3 can be seen. In Scenario 3 User 1 remains statically connected via a PCM cellular interface to MSC 1 (502) initiated in the well-known manner. User 2 transfers from a PCM-based connection with MSC 2 (504) to an RTP-based session with the MGW 150. In the original cellular call MSC 1 and MSC 2 are connected via a trunk line (506). At step 510 User 2 sends an IS-95/IS-2000 measurement report (R-CQICH) to MSC 2 notifying MSC 2 of the target MSC with which it may communicate after handoff. The target MSC in this case is the virtual MSC; i.e., the MGW 150. At step 515 MSC 2 sends an ANSI-41 “HANDMREQX2” in order to request the handover. SCP 140 returns an ANSI-41 “handmreqx2” to MSC 2 at step 520. SCP 140 then begins the process of initiating an RTP session between User 2 and the MGW 150 by sending a SIP SUBSCRIBE message to the mobile handset of User 2 at step 525. At step 530 User 2 sends a SIP NOTIFY message to the SCP 140. User 2 monitors the air interface and when the interface between it and the base station connected to MSC 2 deteriorates below a certain predetermined threshold it send a SIP NOTIFY message to SCP 140 at step 535. At step 540 the SCP 140 sends a SIP INVITE message to User 2 requesting the initiation of a RTP session between it and the MGW 150. At step 545 a similar INVITE request is sent from the SCP 140 to the MGW 150 requesting the initiation of a RTP session between the MGW 150 and User 2. At step 550 the RTP session has been established. The communication session between User 1 and User 2 now occurs along the following path. User 1 continues to communicate with MSC 1 through a PCM cellular call 502. MSC 1 continues to communicate with MSC 2 through trunk line 506. MSC 2 communicated with the MGW 150 through the PSTN in a PCM session 560. The final link between User 1 and User 2 is the RTP-based IP session 550 between the MGW 150 and User 2 through the WiFi, WiMAX, or other IP connection to which User 2 is connected.

FIGS. 6A and 6B depict the handoff flow when User 2 transitions from an IP network to a cellular network while User 1 remains statically connected to a cellular network. The original call is originated by ISUP commands 610 between

User 1, MSC 1 and the MGW 150 which sets up a PCM-based call between these elements at 612. SIP commands 620 between SCP 140 and the MGW 150 and User 2 initiates an RTP-based session 622 between User 2 and MGW 150. In order to initiate the transition, SCP 140 sends a SIP SUB-SCRIBE message to the mobile handset of User 2 at step 630 requesting User 2 to monitor the air interface characteristics of its WiFi connection. At step 635 User 2 sends a SIP NOTIFY message to SCP 140 notifying the SCP 140 that it is monitoring the air interface characteristics of its connection to the WiFi or WiMAX access point to which it is connected. Once a predetermined air interface characteristic such as signal-to-noise ratio is detected, User 2 sends a SIP NOTIFY message to the SCP 140 at step 640 to notify the SCP 140 that the handoff should begin. SCP 140 then sends an ANSI-41 "FACDIR2" message to the target MSC (MSC 2) which will be used to communicate with User 2. Target MSC 2 returns an ANSI-41 "facdir2" message to SCP 140.

Call flow for Scenario 4 continues in FIG. 6B where the original call is denoted by the PCM-based session 612 between the MGW 150 and User 1 through MSC 1/PSTN and the RTP-based session 622 between the MGW 150 and User 2. At step 650 the SCP 140 sends a SIP REFER message to User 2 providing the handoff order to User 2. User 2 returns a SIP NOTIFY message to the SCP 140 at step 655. At step 660 User 2 sends an ANSI-41 based "Voice on New Channel" command to MSC 2 alerting MSC 2 that it would like to initiate cellular service through MSC 2. User 2 also sends a SIP NOTIFY command to SCP 140 at step 665 in order to notify SCP 140 that it has initiated service with MSC 2. MSC 2 sends an ANSI-41 MSONCH (MS ON CHANNEL) command to SCP 140 at step 670 thereby notifying the SCP 140 that MSC 2 is now communicating with User 2. SCP 140 must now set up an RTP session between the MGW 150 in communication with MSC 1 and the MGW 150 in communication with MSC 2. At step 675 SCP 140 sends a SIP INVITE message to the MGW 150 in communication with MSC 2/User 2 and that MGW 150 sends a SIP OK message in return at step 676. At step 678 SCP 140 sends a SIP ReINVITE message to the MGW 150 in communication with MSC 1/User 1 and that MGW 150 returns a SIP OK message at step 680. At steps 682 and 684 the SCP 140 sends a SIP ACKNOWLEDGE message to each of the MGWs, thereby respectively establishing an RTP-based session between the two MGWs. With the session now transferred, communication between User 1 and User 2 occurs through a PCM-based session 690 between User 2 and its MGW 150 through MSC 2 continuing in an RTP session 696 between the MGW 150 in communication with User 2 and the MGW 150 in communication with User 1 and finally from the MGW 150 in communication with User 1 through a PCM-based session 694 from that MGW 150 to User 1 through MSC 1. Upon completion of the handoff SCP 140 sends a BYE message to User 2 at step 698.

The above handoff flows are used in systems in which the users are operating mobile handsets in a CDMA-based cellular network. FIGS. 7A-C and 8A-C depict the handoff flow for the transition of a mobile user using a combo-phone in both IP and GSM-based cellular networks. In FIG. 7A User 1 110 is the fixed user connected to the network through the PSTN or a GSM-based cellular network. User 2 120 is originally connected via an IP domain WiFi access point and is transitioning to a non-IP based GSM network. The original call is consists of a PCM-based session 702 between fixed User 1 and the MGW 150 through the PSTN while User 2 is connected via an RTP session 704 between the mobile handset of User 2 through the WiFi access point and the MGW

150. The handover process begins when the handover controller implemented in SCP 140 which at step 710 sends a SIP SUBSCRIBE message to User 2 requesting the mobile handset of User 2 to send notification if certain predetermined handover conditions are met. The mobile handset of User 2 sends a SIP NOTIFY message back to the SCP 140 at step 712 acknowledging receipt of the instruction. The mobile handset of User 2 obtains GSM neighbor information and gathers GSM signal measurement information from BCCH ("Broadcast Control Channel") signals using SI commands SI:[CellID, LAID . . .] 714 and SI:[BCCH Freq List, . . .] 716. Once the mobile handset of User 2 detects the predetermined handover condition the mobile handset sends a SIP NOTIFY message to the SCP 140 at step 720 including the BSIC ("Base Station Identity Code"), BCCH Frequency, BCCH Strength for each candidate GSM cellular base station.

Using the information from the SIP NOTIFY message send at step 720 the handover controller implemented in the SCP 140 uses candidate information to select a target CellID), uses cellID to determine the target MSCID and determines the idle circuit to target MSCID. The SCP 140 then sends a MAP-Prepare Handover Request message at step 730 to the target MSC 130 for the selected cell that includes the IMSI ("International Mobile Subscriber Identity"); ServingCellID; TargetCellID; Channel Type; EncryptionInfo; Handover Cause, . . . Referring to FIG. 7B, the target MSC 130 then begins communicating with the MGW 150 in which it is in communication in a PCM-based session at 740. The target MSC 130 then sends a MAP-Prepare Handover Response message back to the SCP 140 at step 745 that includes the handover number, radio resource list (channel type and rate), . . . The SCP 140 then sends a SIP REFER command to the mobile handset of User 2 at step 746 providing the handoff command to the device. At step 748 the mobile handset of User 2 responds to the SCP 140 with a SIP NOTIFY message. The mobile handset then begins communicating with the base station associated with the target MSC 130 on the new channel at 749/750. The mobile handset then sends a SIP NOTIFY message to the SCP 140 notifying the SCP 140 that the handoff of it from the IP domain to the non-IP domain is complete. The mobile Handset of User 2 is now communicating in the GSM domain 755.

Referring to FIG. 7C, the handoff continues with the initiation of an RTP session between the MGW 150 in communication with User 1 and the MGW 150 in connection with User 2. A MAP-Send-End-Signal-Request/Response is sent between the target MSC 130 communicating with the mobile handset of User 2 and the MGW 150 in communication with User 1 at step 760. To accomplish this a SIP INVITE command it sent from the SCP 140 to the MGW 150 in communication with User 2 at step 762 which responds with a SIP OK message back to the SCP 140 at step 764. The SCP 140 also sends a SIP Re-INVITE message to the MGW 150 in communication with User 1 at step 768 which responds with a SIP OK message at step 770. SCP 140 sends SIP ACK message to both MGW's at steps 772 and 774 respectively. At step 776 the SCP 140 releases the mobile handset with a SIP BYE message and the mobile handset responds with a SIP OK message at step 778. Thus, the RTP session 780 between the mobile handset of User 2 and the MGW 150 in communication with User 1 is terminated and an RTP session 784 between the two media gateways has been established. Call flow now exists from User 1 over a PCM-based session with its MGW 150 at 782 continuing through an RTP session between the respective MGWs at 784. Call flow continues from the MGW 150 to the target MSC 130 through PCM based session 786 and then from the target MSC 130 to the

11

mobile handset of User 2 using GSM based session 788. Handoff is complete and the call continues through this pathway.

Referring to FIG. 8A, User 1 is connected to the PSTN 190 through a PCM-based call session 802. The PSTN 190 is connected to the serving MSC 130 for the mobile handset of User 2 which is in communication with the handset through a standard GSM-based session 804. User 2 is likely to transition from the GSM-based call to an RTP-based call in the IP domain by connecting to a local WiFi access point. The mobile handset of User 2 obtains GSM neighbor information and gathers GSM signal measurement information from BCCH signals using the SI:[CellID, LAID, . . .] and SI:[BCCH Freq list, . . .] at steps 806 and 808 respectively. At step 810 the mobile handset sends a SIP REGISTER message with handoff indication and WiFi BSSID to the SCP 140 after it has detected a WiFi access point and has established an association with the WiFi network and associated VPN or other IP network. At step 812 the SCP 140 returns a SIP OK message to the mobile handset of User 2. At step 820 the SCP 140 sends a SIP SUBSCRIBE message to the mobile handset requesting the mobile handset of User 2 provide information on WiFi signal measurements. At step 822 the mobile handset of User 2 sends a SIP NOTIFY message to the SCP 140 including BCCH measurements, BCCH strength, FREQ, BSIC and WiFi measurements. The SCP 140 controller assigns WiFi BS ID that correlates to target WiFi BSSID and forwards this to the mobile handset of User 2 using a SIP REFER message at step 830. The mobile handset of User 2 then forwards the WiFi BS ID pilot strength measurements, including the WiFi BS ID as the most desirable target BS, to the RAN 135 and MSC 130 at steps 832 and 834.

Referring to FIG. 8B, the MSC 130 uses the information regarding the handoff candidate to select the target cellID; in this case the WiFi BS ID. The MSC 130 uses the cellID to determine the target MSC ID which in this case will be the handover controller "MSC". Additionally, the MSC 130 determines the idle circuited to target MSCID which corresponds to the handover controller MSC. This information is then forwarded and sent to the SCP 140 handover controller in the form of a MAP-Prepare Handover Request message at step 840. The MAP-Prepare Handover Request message includes the Handover Request; IMSI, ServingCellID, TargetCellID, ChannelType, EncryptionInfo, Handover-cause, At step 842 the SCP 140 begins initiation of an RTP session between the mobile handset of User 2 and the associated MGW 150 using a SIP INVITE message sent to the mobile handset at step 842 which responds with a SIP OK message at step 844. At step 846 the SCP 140 sends a SIP INVITE message to the MGW 150 which responds with a SIP OK message at step 848. SCP 140 then acknowledges initiation of the RTP session 892 with SIP ACK messages sent to the mobile handset of User 2 and the MGW 150 at steps 850 and 852 respectively.

Referring to FIG. 8C, the SCP 140 sends a MAP-Prepare Handover Response message containing information including the Handover Number and the Radio Resource List (channel type and rate) to the MSC 130 at step 860. The MSC 130 then sends a handover command to the RAN 135 at 862 which forwards it to the mobile handset at step 864 which then switches to the SIP session. Information now flows from the mobile handset of User 2 to the MGW 150 via an RTP session 892. The MGW 150 then communicated with the MSC 130 via a PCM session 894 and the MSC 130 communicates with User 1 via PCM through the PSTN 190 at 896. At step 870 the mobile handset sends a SIP NOTIFY message to the SCP 140 notifying the SCP 140 that the handoff is complete. At steps

12

875 and 880 the SCP 140 and the MSC 130 trade MAP-Send-End-Signal-Request and MAP-Send-End-Signal-Response messages to signal the completion of the handover and terminate the GSM-based session.

SCP 140 can either keep call state information or the system can be implemented so that call state information is not kept in the SCP 140. Handoff Controller of SCP 140 must direct that an initial connection be transformed into a new connection in response to a handoff.

FIG. 9 depicts the Handoff Controller 144 and its SIP interfaced to the mobile handset 120 SE/VFAS 910 is Voice Feature Application Server that is part of ISCP. The Handoff Controller 144 resides in the SCP 140 and executes media-independent policies and business rules in order to determine the appropriate time for handoff. The Handoff Controller 144 adapts between various protocols and access technology requirements and interacts with legacy infrastructure such as GSM or CDMA. Handoff Controller 144 is also able to generate usage records for billing purposes. The Handoff Controller 144 includes an ANSI 41 interface, a SIP interface and three internal layers: the feature proxy, the session handover manager and the MIH Layer (IEEE 802.21). In the mobile handset there is also an MIH layer and two radio interfaces—either CMDA or GSM and WiFi or WiMAX. The mobile handset should be capable of monitoring both wireless networks. It must also be capable of sending events to the Handoff Controller 144. The mobile handset can request handovers and may also provide for user input to "force" a handover. The MIH layer implements the use of 802.21 primitives in SIP messages as further described in FIGS. 10 and 11 for CDMA implementations and in FIGS. 12 and 13 for GSM implementations.

ANSI-41 is used to support the handoff from CDMA to WiFi/WiMAX and vice versa. ANSI-41 messages provide coordination of cell identification between neighboring MSCs. ANSI-41 messages use Serving/Target cell identifiers (IDs) to coordinate handoff. ServingCellID and TargetCellID used in FacilitiesDirective2, HandoffBack2, Handoff-ToThird2 INVOKE.

ANSI-41 also provides coordination of inter-MSC facility identification between neighboring MSCs. ANSI-41 assumes dedicated trunks for intersystem handoff. ANSI-41 messages use Circuit IDs to coordinate handoff. InterMSCCircuit is used in FacilitiesDirective2, HandoffBack2, Handoff-ToThird2 INVOKE. Dedicated trunks are required between Media Gateway (MGW) and Serving MSC and Target MSC for proper handoff. There is a need to maintain trunk status information to assign available trunk circuit for handoff. ANSI-41 defines Blocking, Unblocking, ResetCircuit, TrunkTest, and TrunkTestDisconnect operations for inter-MSC circuit management.

ANSI-41 operations used in a handoff forward are: HandoffMeasurementRequest(2); FacilityDirective(2); MSCOn-Channel; and InterSystemAnswer. HandoffMeasurementRequest(2) is sent from the serving MSC to the candidate MSC to request measurement data regarding signal quality level of any specific channel. FacilityDirective (2) is sent from the serving MSC to the Target MSC to request handoff forward. The FacilityDirective(2) ("FACDIR2") message contains a number of mandatory parameters: MIN based on known MS information; ESN based on known MS information; BillingID which is populated based on the BillingID assigned to the current call (potential Segment Count increment); InterMSCCircuitID which the HC selects an idle circuit between itself and the target MSC; InterSwitchCount which the HC calculates (i.e., set to 1 if anchor MSC, else increments prior value); ServingCellID which is the ID of the

13

current cell in the serving MSC. This parameter may be used by the target MSC as the mechanism to determine which MSC is currently serving the MS. Based on the above, the Hand Controller 144 can populate a common (pre-defined) value for the ServingCellID whenever it invokes handoff procedures. This specific value needs to be configured in all potential target MSCs and used to map back to the “MSC” as provided by the SCP/HC.

The FacilityDirective(2) message contains a number of optional parameters. CDMA-based procedures fro handoff support the following parameters. HandoffReason indicates the reasons for the handoff. HandoffState indicates that MS is currently involved in a call that is in an “awaiting answer” or “alerting state” and supports ISAnswer treatment. ConfidentialityModes indicates status of Voice Privacy and Signaling Message Encryption features and whether these features are desired after handoff. SignalMessageEncryptionKey is included for Voice Privacy an Signaling Message Encryption features, CDMA_CallMode indicates what channel types are acceptable (CDMA, AMPS and/or NAMPS). CDMA_ChannelData provides information related to the current CDMA traffic channel that is in use (frame offset, channel number, band class, long code mask). CDMA_MobileProtocolRevision is based on “CDMA MOB_P_REV” information. CDMA_PrivateLongCodeMask is used in conjunction with the Voice Privacy feature. CDMA_ServingOneWayDelay is the estimated one-way delay from MS to serving BS in units of 100 nanoseconds and is convertible to an estimated distance. CDMA_StationClassmark includes MS power class, analog transmission, slotted mode indicator and dual-mode indicators. CDMA_TargetMAHOList is included for mobile-assisted HO and provides a set of TargetCellID/CDMA_PilotStrength/CDMA_TargetOneWayDelay information. CDMA_TargetMeasurementList is included if MAHO is not used and provides a set of TargetCellIP/CDMA_PilotStrength/CDMA_TargetOneWayDelay information. MSLocation provides the latitude and longitude resolution information for the MS.

MSCOnChannel is sent from the Target MSC to the Serving MSC to indicate that the Mobile Handset was detected on the new channel. InterSystemAnswer is sent from the target MSC to the serving MSC to indicate that the MS-terminated call was answered. In addition the InterSystem Answer command is also sent from the serving MSC to the Target MSC to indicate that the MSC-originated call was answered.

With regard to handoff backward and path minimization the following ANSI-41 operations are used. HandoffBack(2) is send from the serving MSC to the target MSC to request that a call be handed back to the target MSC. The Facilities-Release operation is sent from the target MSC to the serving MSC to request that allocated resources for a call segment be released. The HandOffToThird(2) operation is end from the serving MSC to the anchor MSC to request path minimization.

Other ANSI-41 Operations that have applicability to the present invention include the AuthenticationDirectiveForward, InformationForward, FlashRequest, SMSDeliveryBackward, SMSDeliveryForward, IntersystemPage(2) and IntersystemSetup. The AuthenticationDirectiveForward operation supports unique challenges (post-handoff) send from the anchor MSC to the serving MSC. The Information-Forward operation allows the MWN or CE alert to be passed down the handoff chain from the anchor MSC to the serving MSC. The FlashRequest operation allows a flash indication to be sent from the serving MSC to the anchor MSD. The SMS-DeliveryBackward and SMSDeliveryForward operations support SMS origination and termination under handoff con-

14

ditions. The IntersystemPage(2) and InterSystemSetup operations support call delivery in border cell situations.

In ASI-41, mid-call features that are invoked when a call has been handed-off are handled by the Anchor MSC, not the new serving MSC. In ANSI-41, a FLASHREQ command is used to pass information regarding mid-call events from the serving MSC to the anchor MSC.

When a call is handed off from WiFi to CDMA, the mobile handset operates as normal in CDMA mode and the MSC sends a FLASHREQ to the Handover Controller. The Handover Controller implements a pseudo-combo phone SIP interface and translates the received flash request into appropriate SIP signaling messages, i.e. flash hook causes the Handover Controller to put the call on hold using Third Party Call Control (“3PCC”) signaling to the MGC and the remote party.

When a call is handed off from CDMA to WiFi/WiMAX, then the handset must emulate the CDMA operation. Specifically, when the handset is in the “handoff mode,” the Handover Controller will invoke the SUBSCRIBE/NOTIFY with Key Press Markup Language (“KPML”) event package to monitor the handset for flash hook with digits dialed. The mobile handset will deliver flash requests using NOTIFY rather than actually attempting to implement the feature as in “normal mode”. Handover Controller will receive NOTIFY and translate the received signals into FLASHREQ and send to them to the anchor MSC.

Mobile Handset 120 should have the following capabilities. Mobile Handset should support MIH to interact with two radio layers (Layer1 and Layer2). Mobile Handset should measure the pilots and report measurement to MIH rather than transmitting. Mobile Handset should establish a virtual private network (VPN) to exchange SIP signaling while on a CDMA call. When receiving the Handoff message though MIH, it should move to a normal state of transmission. When forcing a hard handoff from CDMA to WiFi, the Mobile Handset should be able to support the SUBSCRIBE/NOTIFY mechanism required by the MIES. For feature operation the Mobile Handset should be able to support a “handoff mode” of operation for Registration and Feature Operation.

The above-described embodiments of our invention are intended to be illustrative only. Numerous other embodiments may be devised by those skilled in the art without departing from the spirit and scope of the present invention.

We claim:

1. A method for using a handoff controller for handing off a communication session of a first communication device from a first network to a second network, wherein the first network is one of an Internet Protocol (IP) network and a cellular network and the second network is a different one of the IP network and the cellular network as compared to the first network, and wherein the first communication device is in communication with a second communication device, the method comprising:

55 sending a Session Initiation Protocol (SIP) message from the handoff controller to the first communication device instructing the first communication device to monitor at least one predetermined characteristic of an interface between the first communication device and the first network;

60 receiving at the handoff controller an SIP message from the first communication device when a value associated with the at least one predetermined characteristic has been met to provide a received SIP message;

65 receiving at the handoff controller network information regarding available connection points in the second network;

15

determining in the handoff controller, based on the received SIP message and the network information, one of the available connection points in the second network to which the first communication device shall be connected;

5 sending a further SIP message from the handoff controller to the first communication device identifying the one of the available connection points in the second network; and

effecting, by the handoff controller, a seamless handoff of the first communication device from the first network to the second network via the identified one of the available connection points so as to allow continued communication between the first communication device and the second communication device;

10 wherein the SIP messages contain 802.21 Media Independent Handover Function (MIHF) service primitives, with the handoff controller performing the steps as a function, at least in part, of the 802.21 MIHF service primitives.

15 **2.** The method for using a handoff controller as claimed in claim 1, wherein the handoff controller is configured to utilize an 802.21 MIH layer to process the 802.21 MIHF service primitives.

3. The method for using a handoff controller as claimed in claim 1, wherein the 802.21 MIHF service primitives are independent of protocols and access technologies associated with IP networks and cellular networks and IP components and cellular components.

4. The method for using a handoff controller as claimed in claim 1, wherein effecting a seamless handoff includes establishing a Real-time Transport Protocol (RTP) session through SIP messaging.

5. The method for using a handoff controller as claimed in claim 1, wherein the first communication device is capable of operating in both the IP network and the cellular network.

6. The method for using a handoff controller as claimed in claim 1, wherein the cellular network is one of a Code Division Multiple Access (CDMA) network and a Global System for Mobile Communications (GSM) network.

7. The method for using a handoff controller as claimed in claim 1, wherein the handoff controller resides in a Service Control Point (SCP).

8. The method for using a handoff controller as claimed in claim 1, further comprising generating usage records, via the handoff controller, for the first communication device regarding transition of the first communication device between networks for billing purposes.

9. A method for using a first communication device in connection with a handoff of a communication session of the first communication device from a first network to a second network, wherein the first network is one of an Internet Protocol (IP) network and a cellular network and the second network is a different one of the IP network and the cellular network as compared to the first network, and wherein the first communication device is in communication with a second communication device, the method comprising:

receiving at the first communication device a Session Initiation Protocol (SIP) message from a handoff controller instructing the first communication device to monitor at least one predetermined characteristic of an interface between the first communication device and the first network;

60 sending an SIP message from the first communication device to the handoff controller when a value associated with the at least one predetermined characteristic has been met;

65

16

receiving at the first communication device a further SIP message from the handoff controller identifying one available connection point in the second network, wherein the identified one available connection point is determined by the handoff controller based on the SIP message and additional network information the handoff controller receives which contain information regarding available connection points in the second network; and

5 effecting, through the first communication device, a seamless handoff of the first communication device from the first network to the second network via the identified one of the available connection points so as to allow continued communication between the first communication device and the second communication device; and

10 wherein the SIP messages contain 802.21 Media Independent Handover Function (MIHF) service primitives, with the first communication device performing the steps as a function, at least in part, of the 802.21 MIHF service primitives.

10. The method for using a first communication device as claimed in claim 9, wherein the first communication device supports use of the 802.21 MIHF service primitives.

11. The method for using a first communication device as claimed in claim 9, wherein the 802.21 MIHF service primitives are independent of protocols and access technologies associated with IP networks and cellular networks and IP components and cellular components.

12. The method for using a first communication device as claimed in claim 9, wherein effecting a seamless handoff includes establishing a Real-time Transport Protocol (RTP) session through SIP messaging.

13. The method for using a first communication device as claimed in claim 9, wherein the first communication device is capable of operating in both the IP network and the cellular network.

14. The method for using a first communication device as claimed in claim 9, wherein the cellular network is one of a Code Division Multiple Access (CDMA) network and a Global System for Mobile Communications (GSM) network.

15. An apparatus comprising a handoff controller for handing off a communication session of a first communication device from a first network to a second network, wherein the first network is one of an Internet Protocol (IP) network and a cellular network and the second network is a different one of the IP network and the cellular network as compared to the first network, and wherein the first communication device is in communication with a second communication device, the handoff controller comprising:

a Session Initiation Protocol (SIP) interface configured to send and receive SIP messages;

an 802.21 Media Independent Handover (MIH) processing part configured to process 802.21 Media Independent Handover Function (MIHF) service primitives; and

55 a session handover manager configured to effect the handing off of the communication session of the first communication device from the first network to the second network by:

sending an SIP message to the first communication device instructing the first communication device to monitor at least one predetermined characteristic of an interface between the first communication device and the first network;

receiving an SIP message from the first communication device when a value associated with the at least one predetermined characteristic has been met to provide a received SIP message;

17

receiving network information regarding available connection points in the second network;
determining, based on the received SIP message and the network information, one of the available connection points in the second network to which the first communication device shall be connected;
5 sending a further SIP message to the first communication device identifying the one of the available connection points in the second network; and
effecting a seamless handoff of the first communication device from the first network to the second network via the identified one of the available connection points so as to allow continued communication between the first communication device and the second communication device;
15 wherein the SIP messages contain 802.21 MIHF service primitives, with the session handover manager performing, at least in part, as a function of the 802.21 MIHF service primitives.

16. The apparatus comprising a handoff controller as claimed in claim 15, wherein the 802.21 MIHF service primitives are independent of protocols and access technologies associated with IP networks and cellular networks and IP components and cellular components.

17. The apparatus comprising a handoff controller as claimed in claim 15, wherein effecting a seamless handoff includes establishing a Real-time Transport Protocol (RTP) session through SIP messaging.

18. The apparatus comprising a handoff controller as claimed in claim 15, wherein the cellular network is one of a Code Division Multiple Access (CDMA) network and a Global System for Mobile Communications (GSM) network.

19. The apparatus comprising a handoff controller as claimed in claim 15, wherein the handoff controller resides in a Service Control Point (SCP).

20. The apparatus comprising a handoff controller as claimed in claim 15, wherein the handoff controller may be configured to generate usage records for the first communication device regarding transition of the first communication device between networks for billing purposes.

21. A tangible computer-readable medium having stored thereon computer-executable instructions that, if executed by a computing device, cause the computing device to perform a method for handing off a communication session of a first communication device from a first network to a second network, wherein the first network is one of an Internet Protocol (IP) network and a cellular network and the second network is a different one of the IP network and the cellular network as compared to the first network, and wherein the first communication device is in communication with a second communication device, the method comprising:

sending a Session Initiation Protocol (SIP) message from the computing device to the first communication device instructing the first communication device to monitor at least one predetermined characteristic of an interface between the first communication device and the first network;

18

receiving at the computing device an SIP message from the first communication device when a value associated with the at least one predetermined characteristic has been met to provide a received SIP message;
5 receiving at the computing device network information regarding available connection points in the second network;
determining in the computing device, based on the received SIP message and the network information, one of the available connection points in the second network to which the first communication device shall be connected;
sending a further SIP message from the computing device to the first communication device identifying the one of the available connection points in the second network; and
effecting, by the computing device, a seamless handoff of the first communication device from the first network to the second network via the identified one of the available connection points so as to allow continued communication between the first communication device and the second communication device;
wherein the SIP messages contain 802.21 Media Independent Handover Function (MIHF) service primitives, with the computing device performing the steps as a function, at least in part, of the 802.21 MIHF service primitives.

22. The tangible computer-readable medium as claimed in claim 21, wherein the computing device is configured to utilize an 802.21 MIH layer to process the 802.21 MIHF service primitives.

23. The tangible computer-readable medium as claimed in claim 21, wherein the 802.21 MIHF service primitives are independent of protocols and access technologies associated with IP networks and cellular networks and IP components and cellular components.

24. The tangible computer-readable medium as claimed in claim 21, wherein effecting a seamless handoff includes establishing a Real-time Transport Protocol (RTP) session through SIP messaging.

25. The tangible computer-readable medium as claimed in claim 21, wherein the first communication device is capable of operating in both the IP network and the cellular network.

26. The tangible computer-readable medium as claimed in claim 21, wherein the cellular network is one of a Code Division Multiple Access (CDMA) network and a Global System for Mobile Communications (GSM) network.

27. The tangible computer-readable medium as claimed in claim 21, wherein the computing device resides in a Service Control Point (SCP).

28. The tangible computer-readable medium as claimed in claim 21, further comprising instructions that, if executed by the computing device, cause the computing device to perform generating usage records for the first communication device regarding transition of the first communication device between networks for billing purposes.

* * * * *

UNITED STATES PATENT AND TRADEMARK OFFICE
CERTIFICATE OF CORRECTION

PATENT NO. : 7,664,501 B2
APPLICATION NO. : 11/436742
DATED : February 16, 2010
INVENTOR(S) : Dutta et al.

Page 1 of 1

It is certified that error appears in the above-identified patent and that said Letters Patent is hereby corrected as shown below:

On the Title Page:

The first or sole Notice should read --

Subject to any disclaimer, the term of this patent is extended or adjusted under 35 U.S.C. 154(b) by 502 days.

Signed and Sealed this

Thirtieth Day of November, 2010

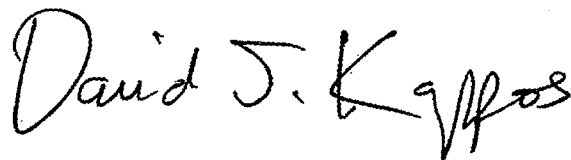
A handwritten signature in black ink that reads "David J. Kappos". The signature is written in a cursive, slightly slanted style.

David J. Kappos
Director of the United States Patent and Trademark Office