

17175 U.S. PTO
010604

Under the Paperwork Reduction Act of 1995, no persons are required to respond to a collection of information unless it displays a valid OMB control number.

PROVISIONAL APPLICATION FOR PATENT COVER SHEET

This is a request for filing a PROVISIONAL APPLICATION FOR PATENT under 37 CFR 1.53(c).

Express Mail Label No. ER 315443706 US

INVENTOR(S)					
Given Name (first and middle [if any])		Family Name or Surname		Residence (City and either State or Foreign Country)	
MUN KEUNG		LEUNG		REDWOOD CITY CALIFORNIA	
Additional inventors are being named on the <u>0</u> separately numbered sheets attached hereto					
TITLE OF THE INVENTION (500 characters max)					
Radiotelephone with Automatic Switching between Cellular and Wi-Fi Networks Using Wi-Fi Signal Strength Values					
Direct all correspondence to: CORRESPONDENCE ADDRESS					
<input type="checkbox"/> Customer Number: 					
OR					
<input checked="" type="checkbox"/> Firm or Individual Name		IC CORP			
Address		3175 ARCOLA CT			
Address					
City		SAN JOSE		State	CA
Country		U.S.A.		Zip	95148
		Telephone	(408) 482-1695	Fax	
ENCLOSED APPLICATION PARTS (check all that apply)					
<input checked="" type="checkbox"/> Specification Number of Pages <u>6</u>		<input type="checkbox"/> CD(s), Number _____			
<input checked="" type="checkbox"/> Drawing(s) Number of Sheets <u>1</u>		<input type="checkbox"/> Other (specify) _____			
<input type="checkbox"/> Application Date Sheet. See 37 CFR 1.76					
METHOD OF PAYMENT OF FILING FEES FOR THIS PROVISIONAL APPLICATION FOR PATENT					
<input checked="" type="checkbox"/> Applicant claims small entity status. See 37 CFR 1.27.				FILING FEE Amount (\$)	
<input type="checkbox"/> A check or money order is enclosed to cover the filing fees.				80.00	
<input type="checkbox"/> The Director is hereby authorized to charge filing fees or credit any overpayment to Deposit Account Number: _____					
<input checked="" type="checkbox"/> Payment by credit card. Form PTO-2038 is attached.					
The invention was made by an agency of the United States Government or under a contract with an agency of the United States Government.					
<input checked="" type="checkbox"/> No.					
<input type="checkbox"/> Yes, the name of the U.S. Government agency and the Government contract number are: _____					

15435 U.S. PTO
60/534466

010604

[Page 1 of 2]

Respectfully submitted,

Date 1/05/2004

SIGNATURE Mun Leung

REGISTRATION NO. _____
(if appropriate)

TYPED or PRINTED NAME MUN KEUNG LEUNG

Docket Number: _____

TELEPHONE (650) 592-1602

USE ONLY FOR FILING A PROVISIONAL APPLICATION FOR PATENT

This collection of information is required by 37 CFR 1.51. The information is required to obtain or retain a benefit by the public which is to file (and by the USPTO to process) an application. Confidentiality is governed by 35 U.S.C. 122 and 37 CFR 1.14. This collection is estimated to take 8 hours to complete, including gathering, preparing, and submitting the completed application form to the USPTO. Time will vary depending upon the individual case. Any comments on the amount of time you require to complete this form and/or suggestions for reducing this burden, should be sent to the Chief Information Officer, U.S. Patent and Trademark Office, U.S. Department of Commerce, P.O. Box 1450, Alexandria, VA 22313-1450. DO NOT SEND FEES OR COMPLETED FORMS TO THIS ADDRESS. SEND TO: Mail Stop Provisional Application, Commissioner for Patents, P.O. Box 1450, Alexandria, VA 22313-1450.

If you need assistance in completing the form, call 1-800-PTO-9199 and select option 2.

Samsung Ex. 1008
Samsung v. Vasu
IPR2025-00447
Page 00001

Provisional Patent Application of

Mun Keung Leung

For

5 TITLE OF INVENTION: Radiotelephone with Automatic Switching between Cellular
and Wi-Fi Networks Using Wi-Fi Signal Strength Values

CROSS-REFERENCE TO RELATED APPLICATIONS: None.

FEDERALLY SPONSORED RESEARCH: None.

SEQUENCE LISTING: None.

10

BACKGROUND OF THE INVENTION

This invention relates to the field of radiotelephone for wireless voice communications. The types of radiotelephone that considered in this application are cellular phone and wireless fidelity (Wi-Fi) phone. The current state of art of a cellular
15 phone is for voice communications in cellular networks only. Similarly, a Wi-Fi phone only works in Wi-Fi networks. This implies that a phone designed for cellular networks does not work in the Wi-Fi networks, or vice versa. This invention presents a radiotelephone that can be used for voice communications in both types of networks, i.e., cellular and Wi-Fi. The radiotelephone comprises of a cellular phone module, a Wi-
20 Fi phone module and a switching component. The cellular phone module enables the radiotelephone to be used in a cellular network for voice communications. While, the Wi-Fi phone module facilitates the voice communications in a Wi-Fi network. The switching component includes the following sub-units: a Wi-Fi signal strength monitor, a timer unit and a network switch unit. The interactions among these sub-units enable
25 the radiotelephone to switch between cellular and Wi-Fi networks automatically during voice communications.

SUMMARY OF THE INVENTION

The invention, a radiotelephone equipped with a cellular phone module and a Wi-Fi phone module can be used in voice communications in both cellular and Wi-Fi networks. It works as any current state of art cellular phone in a cellular network and also functions as any current state of art Wi-Fi phone in a Wi-Fi network. Furthermore, this radiotelephone is equipped with a switching component, which includes a Wi-Fi signal strength monitor, a timer unit and a network switch unit. By monitoring the received Wi-Fi signal strength, the switching component of this radiotelephone can switch an on-going voice communication automatically to different types of networks, either from cellular to Wi-Fi or vice versa.

For switching an on-going voice communication from a cellular network to a Wi-Fi network, the switching component activates the network switching by detecting the increase in Wi-Fi signal strength and measuring the duration for such increase. An audio alert signal is also generated during the actual switching of networks.

On the other hand, for switching from a Wi-Fi network to a cellular network, the switching component activates this type of network switching by detecting the decrease in Wi-Fi signal strength and measuring the duration for such decrease. Similar to the previous case, an audio alert signal is also generated during the actual switching of networks.

A technical advantage of the present invention is that it enables a phone user to use one radiotelephone for voice communications in both cellular and Wi-Fi networks.

Yet another technical advantage of the disclosed invention is the ability to switch between a cellular network and a Wi-Fi network automatically. It also generates an audio alert signal to indicate the switching of networks.

BRIEF DESCRIPTION OF THE DRAWINGS

FIG. 1 depicts the block diagram of a radiotelephone phone with automatic switching between cellular and Wi-Fi networks.

DETAILED DESCRIPTION OF THE INVENTION

FIG. 1 illustrates the invention of a radiotelephone with automatic switching between cellular and Wi-Fi networks. It comprises of the following components: a cellular phone module 3 with a cellular antenna 1, a Wi-Fi phone module 4 with a Wi-Fi antenna 2, an audio amplifier 5, a network switch unit 6, a timer unit 7, a Wi-Fi signal strength monitor 8, a microphone 20 and a speaker 21.

For switching from a cellular network to a Wi-Fi network, Wi-Fi signal strength monitor 8 checks the received Wi-Fi signal strength from the Wi-Fi antenna 2 via the connection 9. If the signal strength is greater than a preset threshold value, V_{sth} , Wi-Fi signal strength monitor 8 activates the timer unit 7 via the connection 10 and sends a network-switching signal to the network switch unit 6 via the connection 12. Network switch unit 6 passes switching signals to the cellular phone module 3 via the connection 15 and to the Wi-Fi phone module 4 via the connection 13. Both phone modules start their corresponding switching procedures. At the same moment, Timer unit 7 starts to record the duration that the received Wi-Fi signal is greater than the threshold value, V_{sth} . If the duration is greater than a preset value D_{ps} , the timer unit 7 sends a cellular tear down signal and a Wi-Fi link up signal to the network switch unit 6 via the connection 11. Upon receiving these signals, network switch unit 6 sends the tear down signal to the cellular phone module 3 via the connection 15 and the link up signal to the Wi-Fi phone module 4 via the connection 13. It also signals the audio amplifier 5, via the connection 14, to generate an audio alert signal that will be reproduced by the speaker 21, which is coupled to the audio amplifier 5 via the connection 19. This alert tone is to notify the phone user of a network switch from cellular to Wi-Fi. When the cellular phone module 3 receives the tear down signal, it terminates the connection to the cellular network and switches off the connection 17 to the audio amplifier 5. At the same time, Wi-Fi phone module 4 activates the connection to Wi-Fi network and switches on the connection 16 for passing voice signal to the audio amplifier 5. The phone conversation is continued though the loudspeaker 21 with connection 19 and the microphone 20 with connection 18.

For switching from a Wi-Fi network to a cellular network, Wi-Fi signal strength monitor 8 checks the received Wi-Fi signal strength from the antenna 2 via the connection 9. If the signal strength is less than a preset value, V_{ps1} , Wi-Fi signal strength monitor 8 activates the timer unit 7 via the connection 10 and sends a network-switching signal to the network switch unit 6 via the connection 12. Network switch unit 6 passes switching signals to the cellular phone module 3 via the connection 15 and to the Wi-Fi phone module 4 via the connection 13. Both phone modules start their corresponding switching procedures. At the same moment, Timer unit 7 starts to record the duration that the received Wi-Fi signal is less than the threshold value, V_{ps1} . If the duration is greater than a preset value D_{ps1} , the timer unit 7 sends a Wi-Fi tear down signal and a cellular link up signal to the network switch unit 6 via the connection 11. Upon receiving these signals, Network switch unit 6 sends the link up signal to the cellular phone module 3 via the connection 15 and the tear down signal to the Wi-Fi phone module 4 via the connection 13. It also signals the audio amplifier 5, via the connection 14, to generate an audio alert signal that will be reproduced by the speaker 21, which is coupled to the audio amplifier 5 via the connection 19. This alert tone is to notify the phone user of a network switch from Wi-Fi to cellular. When the Wi-Fi phone module 4 receives the tear down signal, it stops the connection to the Wi-Fi network and switches off the connection 16 to the audio amplifier 5. At the same time, Cellular phone module 3 activates the connection to cellular network and switches on the connection 17 for passing voice signal to the audio amplifier 5. The phone conversation is continued though the loudspeaker 21 with connection 19 and the microphone 20 with connection 18.

CLAIMS

1. A radiotelephone equipped with a cellular phone module and a Wi-Fi phone module means for supporting voice communications in a wireless manner.
2. The radiotelephone of claim 1 wherein the cellular phone module means for voice communications over cellular networks.

3. The radiotelephone of claim 1 wherein the Wi-Fi phone module means for voice communications over Wi-Fi networks.
4. The radiotelephone of claim 1 wherein the network switch unit means for switching voice communications between a cellular network and a Wi-Fi network.
5. The radiotelephone of claim 1 wherein the Wi-Fi signal strength monitor means for measuring the received Wi-Fi signal strength via the Wi-Fi phone module antenna.
6. The radiotelephone of claim 5 wherein the network switch unit uses measured Wi-Fi signal strength as the trigger for initiating the network switching procedures.
7. The radiotelephone of claim 1 wherein the timer unit means for determining the duration for the radiotelephone has to wait before switching to a Wi-Fi network from a cellular network for voice communications.
8. The radiotelephone of claim 7 wherein the timer unit triggers the final network switching from a cellular network to a Wi-Fi network for voice communications.
9. The radiotelephone of claim 1 wherein the timer unit means for determining the duration for this radiotelephone has to wait before switching to a cellular network from a Wi-Fi network for voice communications.
10. The radiotelephone of claim 9 wherein the timer unit triggers the final network switching from a Wi-Fi network to a cellular network for voice communications.
11. The radiotelephone of claim 1 uses an audio alert signal to indicate the switching between a cellular network and a Wi-Fi network.

ABSTRACT

A radiotelephone equipped with a cellular phone module and a Wi-Fi phone module supports voice communications with automatic switching between a cellular network and a Wi-Fi network. It has the similar voice communication performance as any
5 current state of the art cellular phone and Wi-Fi phone in a cellular network and Wi-Fi network respectively. To facilitate automatic switching between a cellular network and a Wi-Fi network, this radiotelephone contains a Wi-Fi signal strength monitor, a timer and a network switch unit. Based on the received Wi-Fi signal strength, the Wi-Fi signal strength monitor passes a network-switching signal to the network switch unit. Upon
10 receiving the switching signal, the network switch unit initiates the network switching procedures in both cellular and Wi-Fi phone modules. The actual switching occurs when the timer unit sends the tear down/link up signal to the network switch unit. The timer unit only issues the tear down/link up signal when the measured Wi-Fi signal strength meets the signal threshold values for a preset time duration. An audio alert
15 signal is also generated and reproduced by the speaker during the actual switching.

FIG. 1

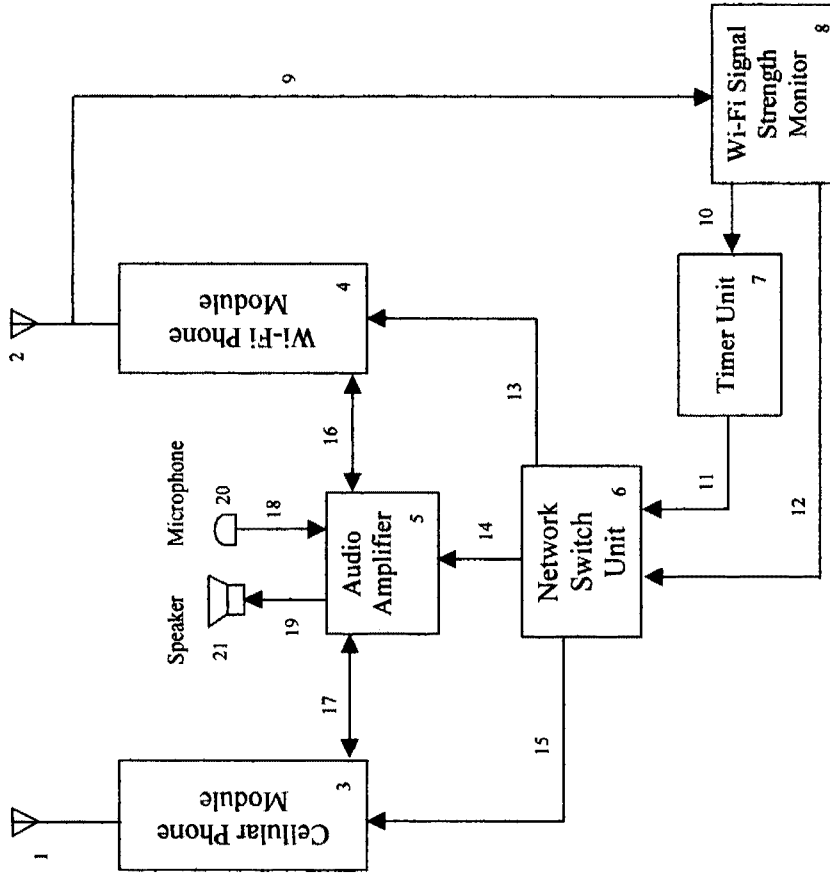

PATENT APPLICATION SERIAL NO. _____

U.S. DEPARTMENT OF COMMERCE
PATENT AND TRADEMARK OFFICE
FEE RECORD SHEET

01/09/2004 WABDELRI 00000130 60534466

01 FC:2005

80.00 DP

PTO-1556
(5/87)