

A Review of DOE/NETL's Mercury Control Technology R&D Program for Coal-Fired Power Plants

Thomas J. Feeley, III¹, James Murphy², Jeffrey Hoffmann², and Scott A. Renninger¹

¹ U.S. Department of Energy, National Energy Technology Laboratory

² Science Applications International Corporation

Abstract

Mercury exists in trace amounts in coal. In the United States, coal-fired power plants emit about 48 tons of mercury and are the largest point source of emissions. The U.S. Environmental Protection Agency has determined the need to control mercury emissions from power plants. In addition, several legislative proposals have been introduced in the 108th Congress to reduce mercury emissions from the electric-utility sector.

Recognizing the potential for mercury regulations, the U.S. Department of Energy/National Energy Technology Laboratory (DOE/NETL) has been carrying out a comprehensive mercury research and development (R&D) program since the early 1990s. Working collaboratively with industry, academia, and EPA, DOE/NETL has helped to advance the understanding of the formation, distribution, and capture of mercury. However, uncertainty remains, particularly related to the overall cost and effectiveness of controlling mercury from a diverse population of coal-fired boilers, as well as the ultimate fate of mercury once it is removed from the flue gas.

This paper provides a summary of the status of DOE/NETL's mercury R&D program, with a focus on the development of advanced emission control technology. The paper also briefly describes research directed at the characterization of mercury in coal utilization by-products (e.g., fly ash) and the transport and transformation of mercury in power plant plumes.

Executive Summary

Mercury exists in trace amounts in fossil fuels (e.g., natural gas, oil, and coal), vegetation, crustal material, and waste products. Through combustion or natural processes, mercury vapor can be released to the atmosphere, where it can drift for a year or more, spreading with air currents over vast regions of the globe. In 1995, an estimated 5,500 tons of mercury was emitted globally from both natural and anthropogenic sources. Coal-fired power plants in the U.S. contributed less than 1 percent of the total. Research indicates that mercury poses both human health and environmental risks, and fish consumption is the primary pathway for human and wildlife exposure.

Mercury emissions have fallen in the United States during the 1990s. In 1993, yearly emissions totaled about 242 tons. By the end of the decade, emissions had declined to less than 160 tons per year. Emissions are expected to continue to fall due to a phasing out of mercury in

commercial products and restrictions placed on emissions from municipal waste combustion and medical waste incineration.

Coal-fired power plants emit an estimated 48 tons of mercury annually, or about one-third of the total U.S. anthropogenic mercury emissions. While mercury emissions from other industrial sectors are being regulated, controls have not yet been placed on electric-utility boilers. However, the U.S. Environmental Protection Agency (EPA) in December 2000 determined a need to regulate mercury emissions from coal-fired power plants because of the “plausible link” between emissions of mercury from these plants and the bioaccumulation of mercury in fish. As a result, EPA has begun development of a maximum achievable control technology (MACT) standard to regulate mercury emissions of power plants. The final MACT regulation is to be issued by December 2004 and compliance would be required by December 2007. Parallel to the MACT process, President Bush introduced the Clear Skies Initiative in February 2002 that would call for a phased-in reduction in mercury from power plants beginning in 2010 and that has been embodied in the Clear Skies Act of 2003. Several other multi-pollutant control legislative bills have been introduced in the 108th session of Congress calling for the regulation of coal-fired power plant mercury emissions.

The challenges of removing mercury from a diverse fleet of more than 300 Gigawatts of coal-fired generating capacity are many. Complicating factors include the type of coal being fired, the design of the boiler and combustion system, the type of downstream conventional control equipment in place, the chemical form of the mercury, the properties of the fly ash, and the relatively low concentration of mercury in flue gas. Today, there is no commercially available technology that can consistently and cost-effectively capture mercury from coal-based power plants.

In response to these challenges, the U.S. Department of Energy/National Energy Technology Laboratory (DOE/NETL) has been carrying out a comprehensive, integrated research and development (R&D) program since the early 1990s to develop low-cost mercury control technologies for coal-fired power plants. Early efforts were directed at characterizing power plant mercury emissions and on laboratory and bench-scale control technology development. The current program is directed at full-scale field-testing of mercury control technologies as well as continued bench- and pilot-scale development of a number of novel control concepts. Field-testing of sorbent injection at four coal-fired power plants and testing at two plants of a proprietary liquid reagent to enhance mercury capture in wet flue gas desulfurization systems have recently been completed. A second phase of longer-term field-testing will be initiated in 2003.

The bench and pilot-scale research includes alternative sorbent technologies, oxidation systems, and methods to enhance mercury capture with conventional particulate, SO₂, and NO_x control equipment. The program also involves fundamental and computational science, an evaluation of the fate of mercury in coal utilization by-products (e.g., fly ash), and the study of the emission, transport, and transformation of mercury in power-plant plumes. As such, the program provides high-quality scientific and technical information on present and emerging environmental issues for use in regulatory and policy decision making.

While our understanding of the formation, distribution, and capture of mercury from electric-utility boilers has evolved, further research is needed in order to allow the Nation’s electric utilities to respond to future mercury regulations in a cost-effective manner. DOE/NETL will

continue its partnership with industry and academia to further the development of advanced mercury control technology and to provide the scientific and technical knowledge needed to help formulate sound regulatory policy.

Background

Emissions of Mercury in the Environment

Mercury exists in trace amounts in coal, waste, and other materials. When these materials burn, mercury is released into the air. In addition to new anthropogenic (man-made) releases, mercury deposited from past anthropogenic releases is re-emitted, contributing significantly to the annual mercury emission pool. In 1995, an estimated 5,500 tons of mercury was emitted globally.¹ Natural sources contribute an estimated 25% to that total. Natural sources include releases from volcanic eruptions, forest fires, and the natural degassing of mercury mineral deposits.

The fraction of 1995 annual global emissions due to U.S. anthropogenic sources was about 3%, or 158 tons. The primary sources of new U.S. anthropogenic releases are burning fossil fuel and waste, processing metals and ores, and producing chlor-alkali. As shown in Figure 1, coal-fired power plants contributed approximately one-third of the total U.S. anthropogenic mercury emissions in 1995. However, U.S. coal-fired power plants contribute only a small fraction, about 1%, of the total worldwide emissions of mercury.

Figure 1 - Source Contributions to 1995 Total U.S. Anthropogenic Mercury Emissions¹

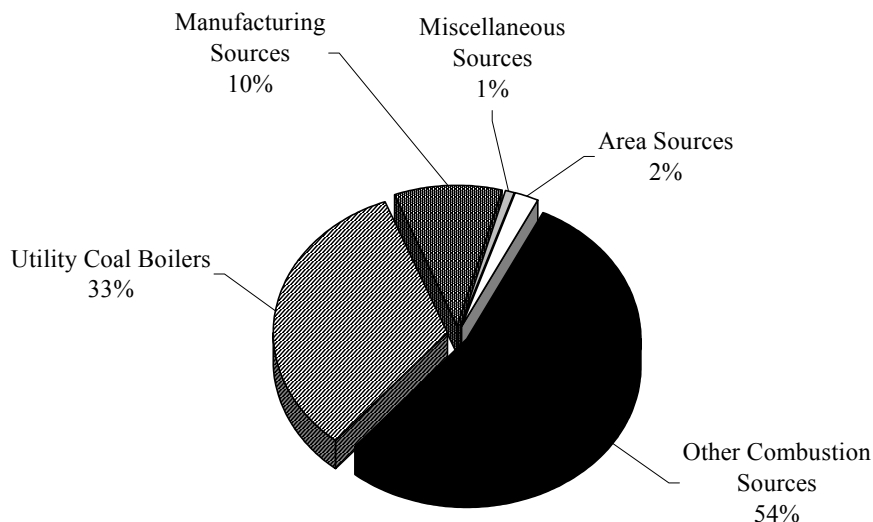

Over the past decade, U.S. anthropogenic mercury emissions from non-power-plant sources have demonstrated significant decline. Many reasons lead to the ongoing reduction, including the following:

- The use of mercury in manufactured products such as batteries, fungicides, and paints has been reduced.

- Municipal-waste and hazardous-waste combustors, and medical waste incinerators have been required to control mercury emissions by the EPA. Final Federal regulations reducing mercury emissions by 90% from municipal waste combustors and by 94% from medical waste incinerators were issued in 1995 and 1997, respectively. In 1998, mercury emissions from hazardous waste combustion facilities were also regulated.
- The number of operating chlor-alkali plants has declined from about twenty in 1990 to twelve in 2000. Those still operating have reduced their mercury use.

Mercury vapors can drift in the atmosphere for long periods. They can spread on air currents over vast regions of the globe or wash out quickly depending on their speciation. The speciation, or chemical form, that mercury takes within the atmosphere is thought to play a significant role in the deposition patterns. The oxidized and particulate-bound fractions are believed to dominate regional wet deposition, and the elemental fraction contributes to the global pool and subsequent long-range transport of mercury.

The behavior of mercury in the environment is complex and not completely understood. Most of the mercury in the atmosphere is believed to be elemental mercury vapor that can circulate for several months to a year and maybe longer.² The dispersion and subsequent deposition of atmospheric mercury can occur locally, primarily when bound to airborne particles or through wet deposition, but a significant portion can be transported thousands of miles from the source. Transformation between the gas-phase forms (oxidized and elemental) is believed to occur in the atmosphere under some circumstances, including in the plume directly exiting the source's stack. However, the extent and specific conditions facilitating the transformation have yet to be determined.

Simulations of long-range transport of mercury have approximated that only one-third of U.S. anthropogenic emissions (about 52 tons in 1995) are deposited within the lower contiguous 48 states. Mercury deposition in the same area from the global pool has been estimated at an additional 35 tons for 1995. The total estimate for mercury deposition in 1995 was approximately 87 tons.¹

U.S. Coal-Fired Power Plant Emissions

In 1999-2000, EPA carried out an Information Collection Request (ICR) to update the mercury emission inventory for U.S. coal-fired power plants. The emission estimate was based on the reported mercury content of the as-fired fuel from over 1,100 boilers. Based on the ICR, coal-fired electric-utility boilers emitted about 48 tons of mercury in 1999, or about one-third of total annual anthropogenic mercury emissions, and represent the largest single source of unregulated mercury emissions in the United States.

The ICR also included speciated mercury data from 79 of the units that participated. The data indicates that the speciation of mercury exiting the stack of individual coal-fired boilers is primarily gas-phase oxidized or gas-phase elemental mercury, but some particulate bound mercury is also present. Figure 2 presents the individual fractional contribution of 1999 speciated mercury emissions from coal-fired power plants.

Figure 2 - Speciated Fractions of 1999 Aggregate Coal-Fired Emissions³

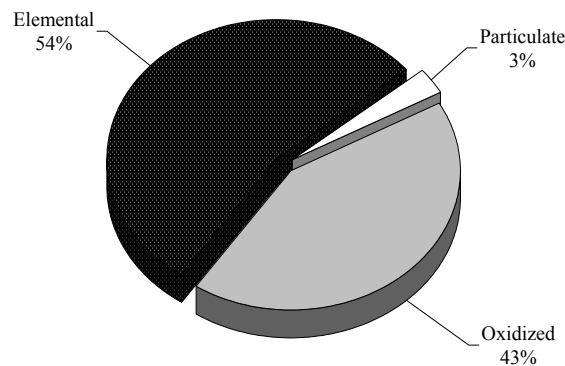

For the same 79 boilers, the ICR database also provides information on the control of mercury across existing air pollution control devices (APCD) for removing nitrogen oxide (NO_x), sulfur dioxide (SO₂), and particulate matter (PM). The capture of mercury across existing APCDs can vary significantly based on coal properties, fly ash properties including unburned carbon, specific APCD configurations, and other factors. ICR data indicates that for pulverized coal (PC) units (the predominant technology currently used for electricity generation) the greatest co-benefit mercury control is realized for bituminous-fired units equipped with a fabric-filter baghouse (FF) for PM control and either wet flue gas desulfurization (FGD) or spray dryer absorber (SDA) for SO₂ control. The worst performing bituminous-fired PC units were equipped only with a hot-side electrostatic precipitator (ESP).

Figure 3 - Mercury Capture Across Cold Side ESP, ICR Raw Data

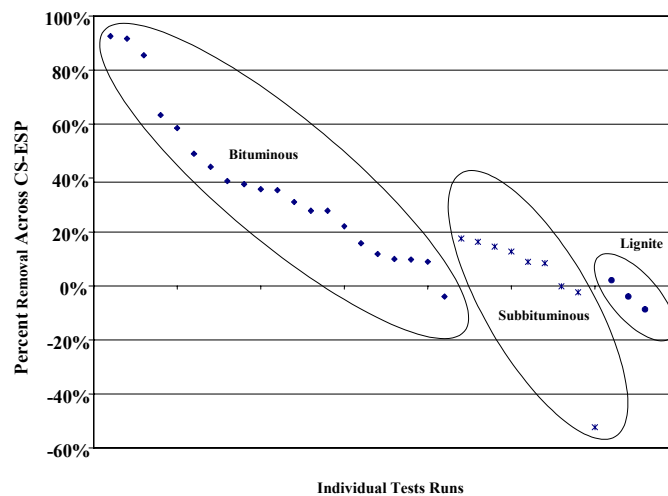

Perhaps one of the most significant findings of the ICR is the fact that units burning subbituminous and lignite coals frequently demonstrated significantly worse mercury capture than a similarly equipped bituminous-fired unit. For example, Figure 3 above presents the percent mercury removal for bituminous, lignite, and subbituminous coal-fired plants with cold-side ESPs that were tested as part of the ICR.

One possible cause of this large variation in mercury capture is that the speciation of mercury in power plant flue gas can vary significantly from plant to plant depending on coal properties and combustion conditions. Figure 4 presents the average coal chloride content for bituminous, lignite, and subbituminous coals as reported in the ICR database. EPA's analysis of the ICR data indicates that plants that burn bituminous coal typically have higher levels of oxidized mercury than plants that burn lignite or subbituminous coal, possibly due to the higher chlorine and/or sulfur content of bituminous coal. For example, the plants burning bituminous coal equipped with a cold-side ESP averaged only 7% elemental mercury at the inlet to the ESP, while plants burning subbituminous coal equipped with a cold-side ESP averaged 70% elemental mercury.⁴ The higher chlorine content may not only affect speciation, but may also help promote the adsorption of elemental mercury onto the surface of activated carbon or fly ash.

Figure 4 - Average Coal Chloride Content of Fuels Burned in 1999⁴

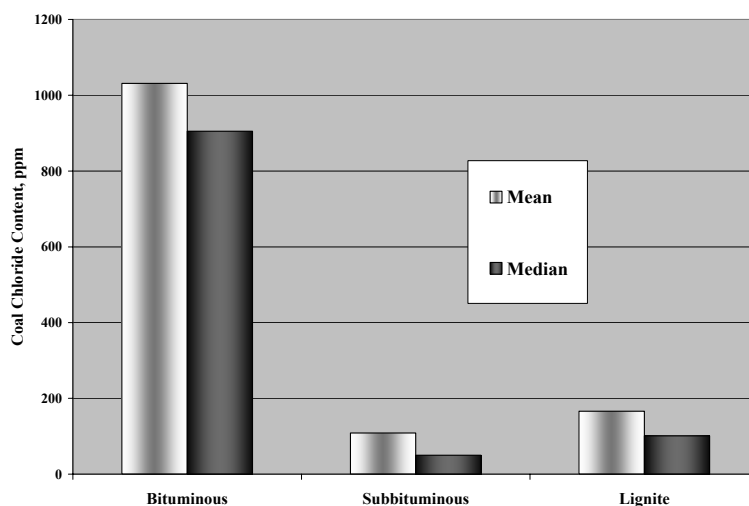

While oxidized and particulate mercury can be effectively captured in some conventional APCDs, such as an ESP, FF, or FGD system, elemental mercury is not as readily captured. The oxidized mercury may be more readily adsorbed onto fly ash particles and collected along with the ash in either an ESP or FF. Also, because the most likely form of oxidized mercury present in the flue gas, mercuric chloride (HgCl_2), is water-soluble, it is more readily absorbed in the scrubbing slurry of plants equipped with wet FGD systems compared to elemental mercury, which is not water-soluble. Therefore, methods to further increase the oxidation of elemental mercury to enhance its capture in existing APCD could be a cost-effective compliance strategy, particularly for coal-fired power plants equipped with wet FGD systems.

Also included in the ICR data was performance information related to mercury capture for less prevalent coal-fired technologies such as cyclone and stoker units, fluidized bed combustion (FBC) units, and integrated gasification combined cycle (IGCC) units. Additionally, data was collected from units burning waste coal, units burning a variety of fuel blends (including blends of different coal ranks), and units co-firing with petcoke.

Data from the ICR campaign has provided a wealth of information that has yet to be fully analyzed. Included within the data are measurements and performance characteristics of all units that were required to participate. Estimates of mercury control across existing devices at individual units demonstrated significant variability both for similar units as well as at a single

unit. Additionally, using EPA's method of grouping similar units together into bins, the ICR data provides for a range of mercury capture performance for different plant configurations, ranging from nearly 100% capture (waste bituminous fired FBC unit equipped with an FF) to 0% capture (lignite-fired PC unit equipped with a cold-side ESP and an FF). In several cases, the ICR data indicates mercury evolution across existing APCDs. Recent testing seems to indicate that the observed mercury evolution may be an actual phenomenon under some circumstances, perhaps due to re-emission of captured mercury. However, at times the evolution may also be a testing artifact due to difficulties with flue gas sampling and/or the analysis method used.

Although the mercury ICR was a significant undertaking and has generated a tremendous amount of useful data, many uncertainties must still be resolved. Several problematic issues associated with the available data make it difficult to garner agreement on the mercury capture performance of existing APCDs. For example, mercury concentrations in power plant flue gas are extremely low, on the order of several parts per billion, which is at the lower limit of what can accurately be measured using current technology. In many cases, speciated testing results reported by EPA were below the testing limit. Furthermore, in some cases observed mercury capture based on stack flue gas concentrations relative to the mercury content of the fuel input do not agree with mercury capture calculated based on flue gas measurements across the control devices sampled for the same dataset. Additionally, although multiple sampling was conducted at each site, the significant variability observed at some individual sites (as well as significant variability observed at similar sites expected to perform equally well) demonstrates that the scientific community has yet to clearly understand the behavior of mercury in power plant flue gas. Finally, the enormous variation of existing coal-fired power plant configurations, as well as the day-to-day variability of the operation of a single unit, raises a question: does the available data (essentially a few snapshots in time) adequately characterize the long-term performance of the existing fleet?

The interpretation of the available data continues today, and EPA has issued several attempts to accurately quantify performance estimates based on the ICR data. While EPA continues to audit and refine the ICR data, periodically making that data available to the public, other organizations including DOE/NETL and the Electric Power Research Institute (EPRI) are conducting independent analysis of the ICR data. EPRI has proposed a correlation between mercury capture and trace-coal constituents such as chloride, sulfur, and calcium. The algorithms developed by EPRI provide support for the observed performance differences related to coal rank because bituminous coals typically have higher chlorine content and lower calcium content than western subbituminous and lignite coals. However, some variables were not included in the detailed ICR testing data, most notably unburned carbon in fly ash, which can have a significant effect on mercury capture in particulate control devices.

Power Plant Mercury Emission Regulations

While many uncertainties remain, the scientific community generally agrees that a) mercury in elevated concentrations is a human health and environmental problem, and b) fish consumption is the primary pathway for human and wildlife exposure. Because of the potential health effects of mercury, Congress included a requirement in the 1990 amendments to the Clean Air Act (CAA) that EPA conduct a study of the emission of mercury and other hazardous air pollutants (HAPs) from utility boilers.

The study resulted in the 1997 *Mercury Study Report to Congress* and the 1998 *Study of Hazardous Air Pollutant Emissions from Electric Utility Steam Generating Units -- Final Report to Congress*. The first report identified coal-fired power plants as the largest source of anthropogenic mercury emissions in the United States. The second concluded that mercury from coal-fired utilities was the HAP (singled out from the 189 substances) of "greatest potential concern" to the environment and human health, thus meriting additional research and monitoring.

In 1999/2000, data was gathered during EPA's Mercury ICR to refine the mercury emission inventory from coal-fired plants and ascertain the mercury control capabilities of existing emission control technologies. Then, in June 2000, the National Academy of Sciences (NAS) released an independent evaluation of mercury health impacts, validating EPA's reference dose for mercury. Finally, on December 14, 2000, EPA determined the need to regulate mercury emissions from coal-fired utilities due to the finding of a "plausible link" between emissions of mercury from power plants and the bioaccumulation of methylmercury in fish.

At the present time, EPA is moving forward with developing MACT regulations for mercury under the CAA's Section 112 – National Emission Standards for Hazardous Air Pollutants. MACT standards are based on the average emission level achieved by the best performing 12% of existing sources, organized by category of industrial sources for which EPA has available data. Once promulgated, HAP reduction requirements are applicable to all sources defined by the MACT standard.

The MACT schedule requires EPA to propose standards for mercury emissions (and any other air toxics deemed necessary) from coal- and oil-fired power plants in December 2003. A final standard is to be issued one year later (December 2004), and compliance is required within three years after regulations become effective (December 2007).

Proposed Multi-pollutant Legislation

In the past several years, Congress has introduced legislation for multiple pollutant control that would limit emissions of SO₂ and NO_x, mercury, and in some cases CO₂ from electric power plants. While the Administration's current position is that the United States will neither participate in the Kyoto Protocol nor require mandatory CO₂ source emission reductions, the expressed interest in multipollutant legislation indicates foreseeable regulatory changes for utility power producers.

The May 17, 2001, National Energy Policy Report recommended the President direct the EPA to work with Congress to develop multipollutant control legislation "that would establish a flexible, market-based program to significantly reduce and cap emissions of SO₂, NO_x, and mercury from electric power generators." Subsequently, on February 14, 2002, the Bush Administration announced its Clear Skies Initiative (CSI) multipollutant control proposal. The proposal would require significant emission reductions of SO₂, NO_x, and mercury through an allowance-based cap-and-trade program. More specifically, CSI calls for a two-phase reduction in mercury emissions below 1999 baseline levels (48 tons) with an approximately 45% reduction beginning in 2010 and a 70% reduction beginning in 2018.

Legislation to adopt CSI as an amendment to the CAA was introduced in both the House and Senate as the Clear Skies Act of 2002 during the 107th Session of Congress. While the bill was not passed, it was reintroduced as the Clear Skies Act of 2003 in the 108th session in February 2003. The Clear Skies Act of 2003 was offered in the House as H.R.999 by Representatives Joe Barton (R-TX) and Billy Tauzin (R-LA) and in the Senate as S.485 by Senators James Inhofe (R-OK) and George Voinovich (R-OH). In addition to the Clear Skies Act, alternative CAA amendments have also been introduced in the 108th Congress. Of those alternatives, the two that have received the most attention are the following:

- S. 366 - The Clean Power Act of 2003 (Sen. Jeffords, I-NH)
- S. 843 - The Clean Air Planning Act of 2003 (Sen. Carper, D-DE)

While the three legislative proposals would all address mercury, they are significantly different on matters such as compliance methods, targets, deadlines, and regional definitions. Additionally, both the Clean Power Act and the Clean Air Planning Act regulate CO₂ to some degree. Table 1 provides a summary of annual mercury emissions under each proposed Act.

Table 1 - Summary of U.S. Mercury Emission Caps Under Proposed Multi-Pollutant Legislation Introduced in the 108th Congress

	2009	2010	2013	2018
Clear Skies Act of 2003		26 tons		15 tons
Clean Air Planning Act of 2003	24 tons		10 tons	
Clean Power Act of 2003	5 tons			

Additionally, except for the Clean Power Act, the proposed legislation provides for a market-based allowance trading system for mercury, similar to the current Acid Rain SO₂ program. While the Clear Skies Act allows for full trading of mercury emissions, the Clean Air Planning Act includes a partial trading program for mercury supplemental to mandatory reductions at individual affected units. The Clean Power Act requires mandatory source reductions and also includes provisions for the development of regulations pertaining to the disposal and utilization of the by-products of coal combustion, prohibiting some current reuse applications.

Mercury Control Issues for Coal-Fired Power Plants

While the regulatory mechanism and exact mercury standard have yet to be determined, it is almost certain that mercury regulations for coal-fired utility boilers will be promulgated. The current regulatory mechanism, MACT, will likely require baseline control limits derived from mercury reduction co-benefits resulting from APCD installed for the control of non-mercury pollutants. Because MACT is required at all affected sources, specific compliance options may require significant capital investment and/or high associated operating costs. Even under a cap-and-trade regulation proposed by some of the multi-pollutant bills, some coal-fired units will more than likely require additional mercury-specific control beyond their current configuration.

Currently, no single technology can cost-effectively provide add-on mercury control for all generating configurations or all fuel types. Early estimates of the cost of mercury control were

as high as \$70,000 per pound of mercury captured. Activated carbon injection (ACI) as a sorbent to capture flue gas mercury has shown the most promise as a near-term mercury control technology. Even so, the application of ACI for mercury capture at coal-fired utility boilers is still in its early stages, and the effectiveness of ACI for mercury capture under varied conditions (e.g., fuel properties, flue-gas temperature, and trace-gas constituents such as chlorine, sulfur, NO_x, and calcium) is still being investigated. Furthermore, the effect of long-term use of ACI (or any other injected sorbent or additive) on plant operations has yet to be determined, and it is likely that some degradation in the performance of downstream equipment, primarily particulate collection devices, may occur. In addition, for utilities that sell their ash, increase in carbon content (or the addition of other chemical compounds) may negatively affect their ability to market the product, and they may incur additional disposal costs. Full-scale testing of activated carbon at one site resulted in unacceptable carbon in ash levels for resale during the entire test period.

Another issue is the impact that increased mercury in coal by-products (e.g., fly ash) may have on disposal requirements under the Resource Conservation and Recovery Act (RCRA). There is the potential that increased partitioning of gas-phase mercury to the solid by-products could result in EPA revisiting the current exemption (the Bevill Exemption) of coal utilization by-products (CUBs) from regulation as hazardous waste. In 2001, more than 121 million tons of CUBs were generated. The costs of managing even a portion of those by-products as hazardous wastes would be significant.

Furthermore, issues pertaining to the uncertainty and variability of the currently accepted testing method, the Ontario-Hydro method, as well as necessary performance and reliability improvements of continuous and semi-continuous mercury emission monitors (CEMs and S-CEMs) need to be resolved before those methods can be reliably implemented as regulatory compliance tools.

DOE/NETL Innovations for Existing Plants Program

A comprehensive, integrated environmental research and development (R&D) program is being carried out under the DOE Office of Fossil Energy's Innovations for Existing Plants (IEP) program. The program, which is managed by DOE/NETL, encompasses both in-house and contracted research on advanced, low-cost environmental control systems and ancillary science and technologies that can help the existing fleet of coal-based power plants meet current and future environmental requirements. The program also provides high-quality scientific information on present and emerging environmental issues for use in regulatory and policy decision making. The research directly supports the Administration's CSI and the May 2001 National Energy Policy recommendations concerning the environmental performance of coal-based power systems.

The IEP portfolio includes bench-scale through field-scale R&D related to the control of mercury, NO_x, particulate matter, and acid gas emissions from power plants, as well as research in the area of ambient air quality, atmospheric chemistry, and solid by-products. Furthermore, the program recognizes the importance of emerging water-related issues and their relationship with reliable and efficient power plant operations. Partnership and collaboration with industry,

Federal and state agencies, research organizations, academia, and non-government organizations are key to the success of the program.

Mercury Control Technology R&D Activities

The challenges of removing mercury from the flue gas of a coal-fired electric utility boiler are many. DOE/NETL, in collaboration with EPRI, industry, academia, and EPA, has made much progress over the past decade in advancing the understanding of the formation, emission, and capture of mercury from power plants. However, technology to cost-effectively reduce mercury emissions from coal-fired power plants is not yet commercially available.

The mercury control technology component of the IEP program is directed at development of a broad suite of low-cost control options to respond to future regulatory decisions, while maintaining a portfolio of supporting research. In Fiscal Year 2003 (October 1, 2002 to September 30, 2003) over \$13 million of the IEP's program's total \$22.2 million budget will be spent on mercury research focused on both near and longer term goals. The near-term goal is to develop mercury control technologies that can achieve 50 to 70% mercury capture at three-quarters or less than current estimated costs for powdered activated carbon injection.^a Those technologies would be available for commercial demonstration by 2005 for bituminous plants and 2007 for lignite and subbituminous coal plants. The longer-term goal is to develop advanced mercury control technologies to achieve 90% or greater capture at one-half to three-quarters the cost of existing technology and that would be available for commercial demonstration by 2010.

In September 2000, DOE/NETL awarded funding for full-scale testing of two approaches to mercury control – activated carbon injection and wet FGD enhancement -- that could meet the IEP short-term goal. In June 2001, additional funding was provided for six bench- and pilot-scale projects focused on developing novel concepts for mercury control that could meet the IEP long-term goal. The IEP program also includes fundamental research to better understand the speciation of mercury in power-plant plumes, as well as the ultimate fate of mercury in coal by-products. In addition, six new mercury projects will be initiated in 2003. Finally, DOE/NETL also participates with the University of North Dakota's Energy & Environmental Research Center (UNDEERC) in a jointly sponsored research program that includes several mercury control technology projects.

In 2003 DOE/NETL will issue a new competitive solicitation to conduct a second phase of full-scale mercury control technology field testing. The scope of this solicitation is to conduct longer-term (one to six months) field testing of advanced mercury control technologies over a broader range of coal type (with a particular focus on low-rank coals) and APCD configurations (e.g., smaller ESPs). The overall goal of the solicitation is to provide cost and performance data to facilitate the design and operation of commercial demonstration projects.

^a Baseline cost estimates for PAC technology are in the range of \$50,000 to \$70,000 per pound mercury removal.

Mercury Control Technology R&D Projects

Large-Scale Field-Testing of Sorbent Injection Technology

Laboratory-, bench-, and pilot-scale studies have shown that sorbent (e.g., activated carbon) injection could be an effective approach for the control of mercury emissions from coal-fired power plants. These studies also suggested that lowering the flue gas temperature using water-spray cooling might aid mercury adsorption and reduce sorbent injection requirements. To more fully evaluate the potential of sorbent injection as a mercury control option, large-scale field-testing was conducted in 2001-2002.

ADA Environmental Solutions (ADA-ES) evaluated the effectiveness of powdered activated carbon (PAC) injection at four coal-fired electric utility boilers. Participants in the program included EPRI, EPA, Alabama Power Company, PG&E National Energy Group, and We Energies (subsidiary of Wisconsin Energy), along with several others. Testing was carried out sequentially at the four host sites described in Table 2.

Table 2 - Description of Plants for Sorbent Injection Testing

Utility Company	Plant	Coal Rank	APCD Configuration	Test Completed
Alabama Power	E.C. Gaston	Low sulfur bituminous	Hot-side ESP and COHPAC	April 2001
We Energies	Pleasant Prairie	Powder River Basin	Cold-side ESP	November 2001
PG&E	Brayton Point	Low sulfur bituminous	Cold-side ESP	August 2002
PG&E	Salem Harbor	Low sulfur bituminous	Cold-side ESP and SNCR	November 2002

The PAC injection system used for the tests consisted of a bulk storage silo and dual pneumatic conveying equipment rated at 750 lb/hr. The PAC is blown into the flue gas duct through a group of injection lances located upstream of the existing particulate control device. The testing at each plant included parametric tests using several commercially available PAC products at various feed rates and operating conditions followed by a one- to two-week, long-term test with a PAC selected from the parametric testing. Figure 5 presents an overall comparison of the mercury removal versus carbon injection rate for the testing at Gaston, Pleasant Prairie, and Brayton Point (Brayton Point data is preliminary).

The following is a brief summary of the test results:

- E.C. Gaston: Testing was completed in April 2001. There was no measurable performance difference between several PACs used during the parametric testing. Norit's Darco FGD activated carbon was used for the nine-day long-term testing. Average compact hybrid particulate collector (COHPAC) inlet mercury concentration

was approximately 11 $\mu\text{g}/\text{dncm}^b$, and 40% of it was elemental. Mercury capture based on three Ontario Hydro tests averaged from 87 to 90% with a carbon injection rate of 1.5 lbs/MMacf. However, the mercury S-CEM data indicated an average capture of 78% that

Figure 5 - PAC Injection Test Results

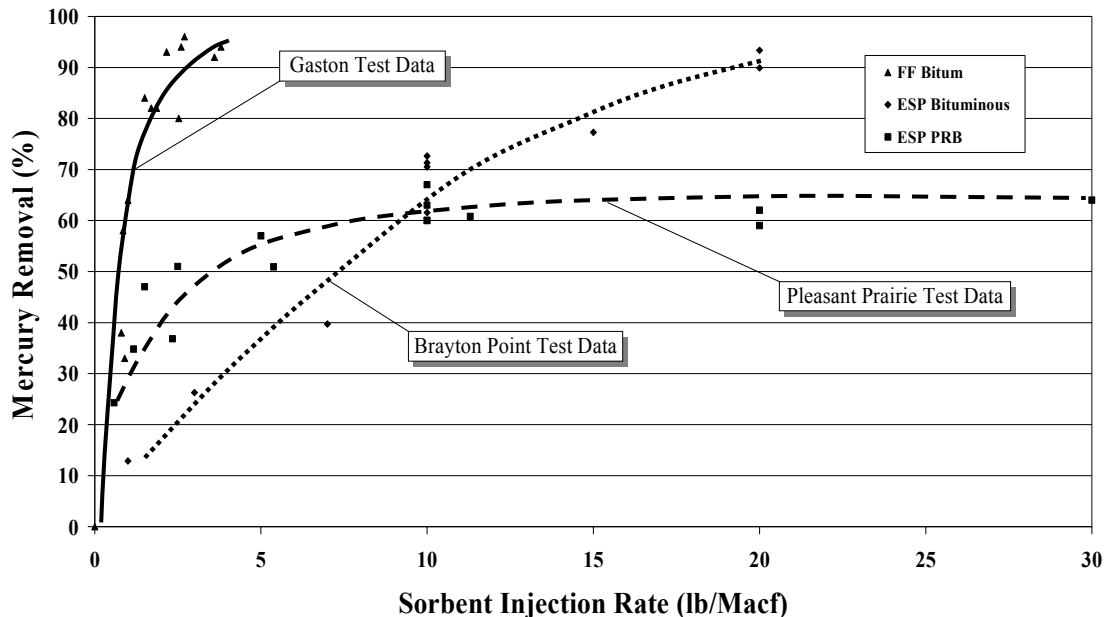

varied from 36% to 90%. The variation in capture efficiency was attributed to changing coal and operating conditions. For example, the COHPAC inlet mercury concentration ranged from approximately 5 to 20 $\mu\text{g}/\text{dncm}$. There was no improvement in mercury capture using the spray-cooling system. An undesired side effect of carbon injection was an increase in the required cleaning frequency of the COHPAC baghouse. Additional testing over longer periods is needed to determine the impact of carbon injection on fabric filter bag life and particulate collection efficiency.⁵

- Pleasant Prairie: Testing was completed in November 2001. Similar to the tests at E.C. Gaston, there was no measurable performance difference between several PACs used during the parametric testing. Norit's Darco FGD activated carbon was used during the three 5-day long-term tests at feed rates of 1.6, 3.7, and 11.3 lb/MMacf. Mercury capture averaged approximately 46%, 57%, and 73%, respectively. Average ESP inlet mercury concentration was approximately 17 $\mu\text{g}/\text{dncm}$, and 85% of it was elemental. During the test period, the carbon injection did not deteriorate ESP performance. However, the ESP at Pleasant Prairie is relatively large (468 SCA) and additional testing needs to be

^b The conventional units of measure used for flue gas mercury concentration is either micrograms per dry standard cubic meter ($\mu\text{g}/\text{dscm}$) or micrograms per dry normal cubic meter ($\mu\text{g}/\text{dncm}$). Both the dscm and dncm measurements are based on standard gas conditions of 0% moisture, 20°C, and one atmosphere pressure. However, a dscm measurement is based on the actual flue gas oxygen concentration while a dncm measurement is corrected to a normal 3% oxygen concentration. Both measurements can be converted to an emission rate of lb/TBtu using the EPA Method 19 F Factor calculation. For example, a mercury concentration of 10 $\mu\text{g}/\text{dncm}$ is equivalent to an emission rate of approximately 7.1 lb/TBtu using the standard F Factor of 9780 dscf/10⁶ Btu for bituminous coal.

conducted on other units with smaller ESPs to evaluate possible degradation of particulate collection efficiency. There was no improvement in mercury capture using the spray cooling system.

A major concern with the PAC injection testing at Pleasant Prairie was that the higher carbon content rendered the fly ash unacceptable for marketing as a concrete additive. This contamination of the fly ash would not only result in lost sales revenue, but would also require additional cost to dispose of the material. Therefore, a comprehensive evaluation of the balance-of-plant impacts needs to be incorporated in any cost analysis of the PAC injection control technology.⁶

- Brayton Point: Testing at the Brayton Point plant was completed in August 2002. However, test results have not yet been published.
- Salem Harbor: Testing at the Salem Harbor plant was completed in November 2002. However, test results have not yet been published.

Large-Scale Field-Testing of Enhanced Mercury Control in Wet FGD

Previous bench- and pilot-scale testing indicated that oxidized mercury can be effectively captured in coal-fired power plants equipped with wet FGD systems. There is also evidence that a portion of the oxidized mercury can be reduced to elemental mercury within the wet FGD system and emitted out the stack. A method to prevent the reduction of oxidized mercury to elemental mercury would enhance the overall mercury capture across the wet FGD system.

In 2001, Babcock & Wilcox and McDermott Technology, Inc. (B&W/MTI) carried out full-scale field testing of a proprietary liquid reagent to enhance mercury capture in coal-fired power plants equipped with wet FGD systems. The B&W/MTI project team included the Ohio Coal Development Office, Michigan South Central Power Agency (MSCPA), and Cinergy.

The field testing was conducted at two power plants, MSCPA's 60 MW Endicott Station in Litchfield, Michigan and Cinergy's 1300 MW Zimmer Station in Moscow, Ohio. Both plants burn Ohio high-sulfur bituminous coal and use cold-side ESPs for particulate control. The Endicott Station utilizes a limestone wet FGD system with in-situ forced oxidation; while the Zimmer Station utilizes a magnesium enhanced lime wet FGD system with ex-situ forced oxidation. The reagent feed equipment consisted of a tanker truck for storage and a skid-mounted feed system with two metering pumps and associated controls. As discussed below, the test results were mixed and further study and evaluation is necessary prior to commercialization of the process.

Three phases of testing were conducted at Endicott. A series of eight parametric tests was conducted at various reagent feed rates ranging from no injection (baseline) to 3 gallons per hour (gph). The 16-day verification testing was conducted to demonstrate consistent day-to-day performance using a constant reagent feed rate of 1 gph at full load. A subsequent four-month test demonstrated there were no long-term deleterious effects on the FGD operation. Testing at Endicott demonstrated the reagent was able to suppress mercury reduction across the wet FGD system. There was no increase in elemental mercury emissions during reagent usage compared

to the baseline increase of over 40%. As a result, total mercury removal averaged 76% during the two-week verification testing compared to the baseline removal of approximately 60%. There was no significant change in the level of oxidized mercury removal which averaged over 90% both with and without reagent usage. A summary of the two-week verification test results is presented in Table 3. Results for the four-month long-term testing were similar with a total mercury removal average of 79% and no increase in elemental mercury emissions. It should be noted that Endicott burns up to four different Ohio coals which resulted in daily average inlet mercury concentrations that ranged from 17 to 27 µg/dscm during the two week verification tests.⁷

Table 3 - Endicott Verification Test Results

Mercury Species	Wet FGD Mercury Removal	
	Baseline	Reagent
Total	~ 60%	76%
Oxidized	~ 90%	93%
Elemental	~ (40%)	20%

Testing at Zimmer included 15 days of verification testing at a reagent feed rate of approximately 27 gph at full load. The reagent testing at Zimmer did not achieve the desired effect. Reduction of oxidized mercury to elemental mercury continued across the wet FGD system during reagent usage. Elemental mercury increased by 41% across the wet FGD system during reagent usage compared to the baseline increase of approximately 20%. There was no significant effect on total mercury removal, which averaged 51% during the two-week verification testing compared to a baseline removal of approximately 45%. The reagent had no significant impact on the level of oxidized mercury removal, which averaged 87% during reagent injection.

A summary of the verification test results is presented in Table 4. No long-term testing was conducted at Zimmer. Possible explanations for the poor results at Zimmer include the much higher sulfite concentration and lower liquid-to-gas ratio in the magnesium enhanced lime wet FGD system, which may have impeded the reagent performance. Similar to Endicott, the Zimmer daily average inlet mercury concentrations varied significantly and ranged from 15 to 34 µg/dscm during the two week verification tests.⁷

Table 4 - Zimmer Verification Test Results

Mercury Species	Wet FGD Mercury Removal	
	Baseline	Reagent
Total	~ 45%	51%
Oxidized	~ 90%	87%
Elemental	~ (20%)	(41%)

The testing at Endicott and Zimmer also included an evaluation of the mercury concentration in the various by-product streams. One of the most significant findings from the test program was that the mercury in the wet FGD waste slurry from both plants was associated primarily with the fines and not bound to the gypsum particles. Therefore, it may be possible to use particle separation techniques to minimize potential mercury contamination of the gypsum.⁷

Pilot Plant Study of Low-Temperature Mercury Capture with an ESP

CONSOL Energy is conducting pilot-scale testing to evaluate the effect of flue gas temperature on mercury capture in plants equipped with ESPs. The project team includes Allegheny Energy, Alstom Power Inc., Environmental Elements Corp., and Carmeuse North America. The pilot-scale testing will be completed in March 2004.

Based on results of the EPA's 1999 mercury ICR, it was determined that existing ESP's are capable of capturing some portion of the mercury in the combustion flue gases. Even so, the mercury capture efficiency of ESPs varies widely from plant-to-plant and is likely not sufficient to meet future EPA regulatory control requirements. Previous research conducted by CONSOL demonstrated that fly ash particles in power plant combustion flue gas can adsorb a significant portion of the mercury if the gas is cooled below typical exhaust temperatures, e.g., from 300° to 200°F. However, operating at reduced flue gas temperatures also results in the condensation of sulfur trioxide (SO₃) that can lead to serious equipment and duct corrosion problems downstream of the air preheater. In order to address the corrosion problem, CONSOL is using an alkaline sorbent injection system to reduce the flue gas SO₃ concentration by approximately 80% to allow for plant operation at the lower flue gas temperatures. The pilot-scale testing is necessary to demonstrate the long-term effectiveness of this control strategy.

Figure 6 - CONSOL Pilot Plant Schematic

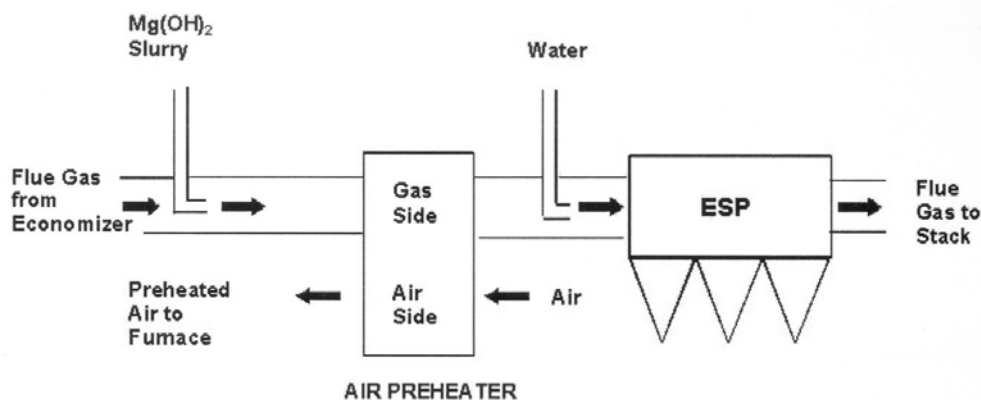

The pilot-scale testing will be carried out at Allegheny Energy's 288 MW Mitchell Power Station, Unit No. 3, located south of Pittsburgh in Courtney, Pennsylvania. The tested unit burns a medium-high sulfur, eastern bituminous coal. The pilot plant consists of an air preheater to lower flue gas temperature, a water-spray cooling system as an optional method to lower flue gas temperature, an ESP to collect the mercury along with the fly ash, and an alkaline sorbent (magnesium hydroxide) injection system to control sulfuric acid condensation. Figure 6 above is a simple schematic diagram of the CONSOL pilot-plant equipment.

The pilot-scale system will treat a 16,500 lb/hr flue gas slipstream taken upstream of the plant's air pre-heater. Mercury capture will be measured across the ESP, and air pre-heater outlet flue gas temperatures will be controlled between 220° to 320°F.

Assessment of Low Cost Novel Mercury Sorbents

Apogee Scientific is conducting pilot testing to assess the mercury capture performance of novel sorbents. Such sorbents could be used as an alternative to commercially available activated carbons in order to enhance performance and reduce operating costs for carbon injection mercury control systems. The project team includes EPRI, URS, Illinois State Geological Survey, ADA Environmental Solutions, Physical Sciences Inc., We Energies, and Midwest Generation. Pilot-scale testing is scheduled for completion in early 2003 and a final report issued by August 2003.

Activated carbon injection (ACI) holds promise as an effective approach to control mercury emissions from coal-fired power plants. Because activated carbon is the largest cost component of ACI systems, the development of alternative lower cost sorbents could significantly reduce the cost of mercury control. This project will assess the mercury capture performance of several low-cost novel mercury sorbents using an actual flue gas slipstream in a small-scale pilot plant equipped with an ESP and baghouse.

The pilot testing is being conducted at two power plants. The Midwest Generation Powerton Generating Station is located in Pekin, Illinois, and burns a Powder River Basin subbituminous coal. The We Energies Valley Plant is located in Milwaukee, Wisconsin, and burns a low-sulfur bituminous coal. The sorbents being tested include activated carbon samples from coal, biomass, and tires; char sorbents made from coal; fly ash-derived sorbents; and zeolite sorbents. Initially, bench-scale laboratory tests were conducted on 46 different sorbents using simulated bituminous coal flue gas and 29 sorbents using simulated PRB coal flue gas. Based on results from the bench-scale testing, 17 sorbents for bituminous applications and eight sorbents for PRB applications were selected for additional fixed-bed testing using actual flue gas slipstreams at the two plants. The fixed-bed testing at the plants will lead to the final selection of sorbents for testing in a small-scale pilot ESP and baghouse.

The Powerton small-scale pilot testing was completed in July 2002 and included experimental sorbents produced from corn, oil soot, waste tires, fly ash, two commercially available carbons made from lignite coal, and an iodine-impregnated sorbent. The small-scale pilot testing at the Valley Plant started in December 2002 and will be completed by the first quarter 2003.

Mercury Control with the Advanced Hybrid Particulate Collector

UNDEERC is conducting bench-scale testing, small pilot-scale testing, and large pilot-scale field demonstration testing to evaluate the mercury control performance of sorbent injection used in conjunction with the Advanced Hybrid Particulate Collector (AHPC). The project team includes W.L. Gore & Associates and Otter Tail Power Company. The bench-scale and small pilot-scale testing were completed in March and June 2002, respectively. The long-term field demonstration pilot-plant testing is scheduled to be completed by the spring of 2003. This project represents a continuation in the development of the AHPC, which is a combination ESP and fabric filter baghouse (FF) system designed to optimize fine particulate collection. Figure 7 shows the general design arrangement of the system.

While sorbent injection used in conjunction with conventional ESPs and FFs is being demonstrated to be effective for mercury capture, the AHPC may be capable of equivalent or better performance at lower sorbent feed rates. Bench-scale and small pilot-scale testing is being conducted at UNDEERC. Large pilot-scale testing is being conducted at Otter Tail Power Company's 450 MW Big Stone Plant located in Big Stone City, South Dakota. The plant burns Powder River Basin subbituminous coal. The bench-scale testing will evaluate mercury capture effectiveness of activated carbon sorbents under varying SO₂ and NO_x flue gas concentrations using both simulated and real flue gas. The small pilot-scale testing will use the 200 acfm UNDEERC particulate test combustor. The goal of the pilot-scale testing is to compare the mercury capture effectiveness, with and without sorbent addition, of a pulse-jet baghouse to that of the AHPC for both an eastern bituminous and a western subbituminous coal. Large pilot-scale testing will use the 9,000 acfm (2.5 MW) AHPC pilot plant previously installed for particulate control demonstration at the Big Stone Plant. A pilot-scale sorbent injection system is being added to the AHPC pilot plant for the mercury control testing using Norit's Darco FGD activated carbon.

Figure 7 - AHPC Design Configuration

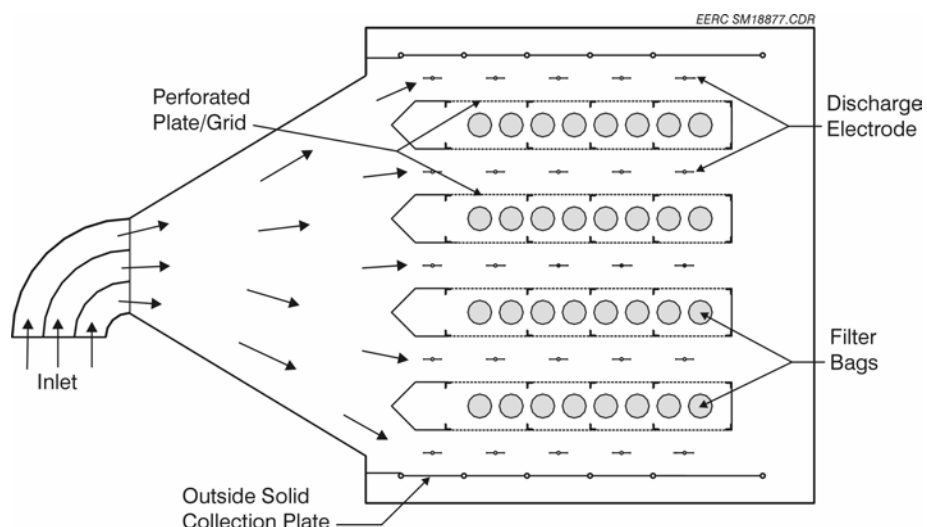

Results from the November 2001 five-day AHPC large pilot-scale testing indicated 91 to 97% total mercury collection efficiency with a sorbent feed rate of 1.5 lb/million acf^c compared to a baseline (no sorbent) mercury collection efficiency of 49%. The relatively high mercury removal rates are somewhat unexpected for low-rank coals and may have occurred due to atypical flue gas speciation. Average inlet mercury speciation during the testing was 55.4% particulate, 38.1% oxidized, and only 6.4% elemental. This is not considered typical for Powder River Basin subbituminous coals, which normally have much higher fractions of elemental mercury. Subsequent analysis showed that the high proportion of particulate and oxidized

^c The 1.5 lb/million acf PAC injection rate is equivalent to that used by ADA-ES during the E.C. Gaston testing with the COHPAC fabric filter where mercury capture averaged from 87 to 90%. However, caution should be exercised in comparing results since the Gaston fuel (low sulfur bituminous) and minimal baseline mercury capture are different from the Big Stone Plant.

mercury may have been related to unexpectedly high levels of chlorine in the flue gas, perhaps due to co-combustion of scrap tires in the Big Stone boiler during the November 2001 test period. A different Powder River Basin coal (Belle Ayr) was used during a second AHPC field demonstration testing in August 2002 and results of these tests are currently being evaluated.⁸

Mercury Removal with the ECO Multipollutant Control Technology

Powerspan Corporation is conducting pilot-scale field-testing to optimize the mercury control performance of the electro-catalytic oxidation (ECO) process multipollutant control technology. The testing is scheduled to be complete by September 2003 and a final report will be issued by March 2004. The technology is a non-thermal, plasma-based multipollutant control concept designed for the simultaneous removal of SO₂, NO_x, and fine particulate emissions from the combustion flue gas of coal-fired boilers. The ECO process includes a dielectric barrier discharge (DBD) reactor to oxidize SO₂, NO_x, and mercury for subsequent removal in an ammonia-based reagent wet FGD system, which produces ammonium sulfate/nitrate fertilizer as a by-product. Fine particulate and aerosols are captured in a wet ESP. Figure 8 shows a simplified flow schematic of the ECO process. Previous pilot-plant testing suggests that the ECO process has the potential for significant mercury removal because the DBD reactor converts the elemental mercury to oxidized mercury as mercuric oxide. The oxidized mercury can then be efficiently captured in the wet FGD absorber.

Figure 8 - ECO Process Flow Schematic

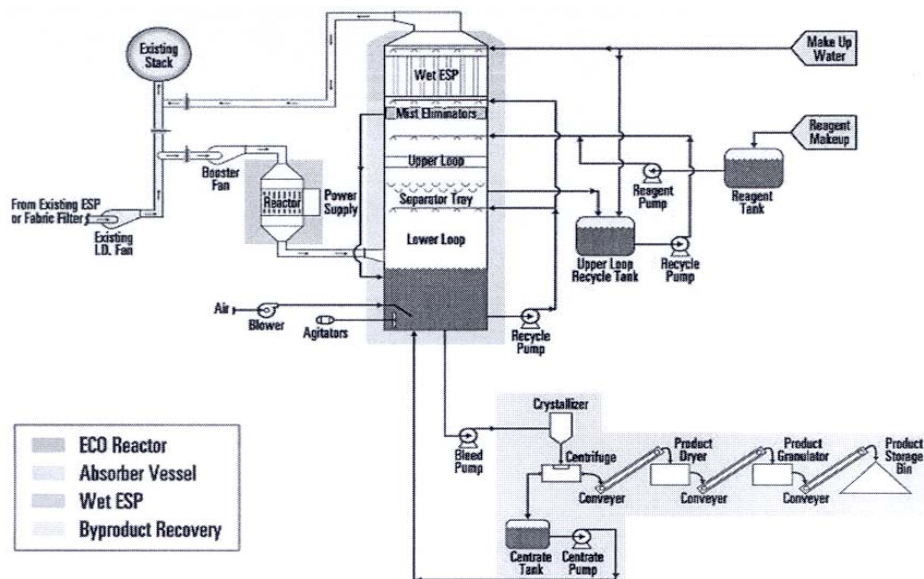

The pilot-scale field-testing is being conducted at FirstEnergy’s R.E. Burger Plant located in Shadyside, Ohio. The plant burns eastern bituminous coal. The testing will use a 3,000 scfm flue gas slip-stream pilot-scale ECO system previously installed for a field test of the process. (Note: A large full-scale 50 MW commercial ECO system is under construction at the R.E. Burger Plant and is expected to be ready for operation by mid-2003.) In addition, an activated carbon filtration system is being developed and installed for removal of the captured mercury

from the wet FGD discharge liquid product stream prior to crystallization of the ammonium sulfate and nitrate by-products.

Preliminary Ontario Hydro method test measurements in May 2002 resulted in an average mercury removal of 88% across the ECO pilot plant. While particulate and oxidized mercury removal exceeded 95%, there was some apparent reduction of oxidized mercury to elemental mercury within the wet FGD system.⁹

Testing of Mercury Control with Calcium-Based Sorbents and Oxidizing Agents

The Southern Research Institute (SRI) is conducting bench-scale and pilot-scale testing to assess the mercury capture performance of calcium-based sorbents and oxidizing agents. Development of calcium-based products could be used as an alternative to commercially available activated carbons in order to enhance performance and reduce operating costs for carbon injection mercury control systems used at coal-fired power plants. The project team includes ARCADIS G&M. The test program consists of numerous pilot-plant runs over a three-year project period, which began in September 2001 and will end in September 2004.

Working with the EPA, ARCADIS has developed two proprietary calcium-based sorbents that could provide for the simultaneous removal of both mercury and SO₂ from coal-fired power plants. One sorbent consists of a hydrated lime, Ca(OH)₂, with an oxidant and the other sorbent consists of a silica-modified calcium, CaSiO₃, with an oxidant. The oxidant is intended to enhance overall sorbent mercury capture by oxidizing gas-phase elemental mercury. SRI is testing the calcium-based sorbents at its Combustion Research Facility located in Birmingham, Alabama, using a 1 MW (1150 scfm) pilot plant. The sorbents are being tested on a variety of coal types and flue gas conditions. The pilot plant sorbent injection system includes a downstream water injection cooling system followed by a fabric filter baghouse for particulate and mercury capture. Initial pilot-scale testing is using a high-volatile, low-sulfur bituminous coal.

The initial pilot-scale testing of the two proprietary sorbents showed both to be ineffective in enhancing the oxidation and capture of elemental mercury and achieved overall mercury removal of only 25 to 50%. Follow-up testing with an ordinary hydrated lime sorbent without the oxidant was able to remove 80 to 90% of the mercury. Capture occurred primarily across the sorbent dust cake collecting on the baghouse filter bags. Subsequent bench-scale testing by ARCADIS indicated the two proprietary sorbents would be more effective in mercury removal with injection at a higher flue gas temperature (i.e. without the water injection cooling) and lower NO_x concentration compared to the initial pilot-plant test conditions. Additional pilot-scale testing will evaluate the sorbent performance with limited or no flue gas cooling and lower concentrations of NO_x and SO₂.¹⁰

Pilot Testing of Mercury Oxidation Catalysts

URS Corporation is conducting pilot testing to evaluate the performance of several catalyst materials to promote the oxidation of elemental mercury in the combustion flue gas. Increasing gas-phase oxidized mercury would enhance overall mercury capture in plants equipped with wet FGD systems. In addition to DOE/NETL and URS, the project team includes EPRI, Great River

Energy (GRE), City Public Service (CPS) of San Antonio, and the North Dakota Industrial Commission. Pilot testing began in October 2002 and will be completed in August 2004.

As discussed previously, oxidized mercury can be effectively captured in coal-fired power plants equipped with wet FGD systems. Therefore, a method to convert the elemental mercury to oxidized mercury in the flue gas would enhance overall mercury capture. A previous DOE/NETL project evaluated several catalyst materials in small, fixed sand-bed reactors that were effective in the oxidation of elemental mercury. This pilot project is necessary to demonstrate the long-term effectiveness of those catalysts on honeycomb substrates that could be used in full-scale commercial applications.

The pilot testing is being conducted at two power plants. The GRE Coal Creek Station is located north of Bismarck, North Dakota, and burns North Dakota lignite. The CPS J.K. Spruce Plant is located in San Antonio, Texas, and burns a Powder River Basin subbituminous fuel. The four catalysts being tested are 1) Pd #1, a commercial palladium catalyst; 2) SCR, a Siemens commercial NOx catalyst using titanium-vanadium; 3) Carbon #6, a tire-derived activated carbon; and 4) SBA #5, an active fly ash. Each of the four catalysts are contained on honeycomb design alumina substrates and mounted in separate 40-inch cube test chambers supplied with approximately a 2,000 acfm flue gas slipstream taken downstream of the plant's particulate control device. The GRE Coal Creek Station pilot testing began in October 2002 and the CPS J.K. Spruce Plant is scheduled to begin in the first quarter 2003. The testing at each plant is scheduled for 14 months.¹¹

Figure 9 - Apparent Loss of Catalyst Activity at Coal Creek.

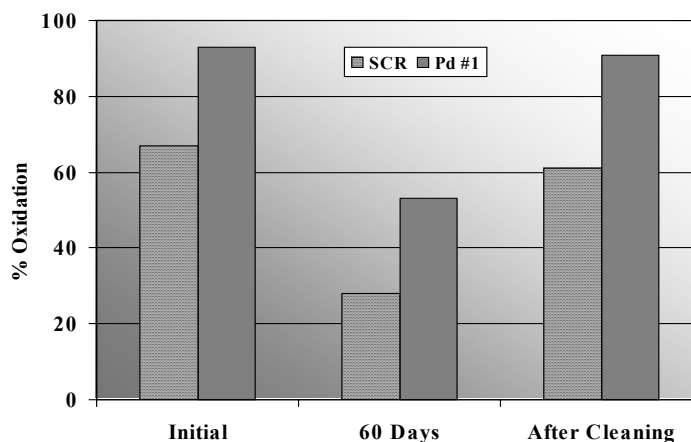

The Coal Creek pilot testing began in October 2002 with the Pd #1 and SCR catalysts. The Carbon #6 and SBA #5 catalysts were not available in October due to manufacturing delays. Testing of the Carbon #6 catalyst began in December 2002 and the SBA #5 catalyst testing was scheduled to begin in March 2003. Preliminary results from the first two months' testing of the Pd #1 and SCR catalysts are shown in Figure 9 above. Initial testing of both catalysts demonstrated some degree of improved mercury oxidation, although the oxidation had decreased over time. The oxidation of elemental mercury across Pd #1 dropped from approximately 95% to 65% after 60 days in service. The oxidation of elemental mercury across the SCR catalyst

dropped from approximately 65% to 30% after 60 days in service. Subsequent inspection of the two catalysts indicated that a buildup of fly ash in the pilot test chamber likely caused the drop in oxidation rather than a loss of catalyst activity since mercury oxidation was restored after cleaning.¹²

Evaluation of Mercury Speciation at Plants Using SCR and SNCR NOx Control Technologies

With support from DOE/NETL, EPRI, and EPA, UNDEERC is carrying out mercury measurements at several coal-fired power plants equipped with selective catalytic reduction (SCR) or selective non-catalytic reduction (SNCR) NOx control technologies. Specifically, UNDEERC will determine the effect SCR and SNCR have on the speciation of mercury in the combustion flue gas and resultant enhancement of mercury captured in downstream pollution control equipment. Numerous electric utility companies have provided host sites for the testing. Testing was performed in 2001-2002 and additional testing will be conducted in 2003. A final report for the 2001 field- testing was issued in December 2002.

Prior UNDEERC pilot-scale testing indicated that the catalyst and/or ammonia reagent associated with SCR and SNCR might convert some of the elemental mercury to oxidized and particulate mercury in the flue gas. As discussed previously, increasing the levels of oxidized and particulate mercury can improve overall mercury capture in a plant's conventional pollution control equipment, such as an ESP, a baghouse, or an FGD system. The purpose of the testing is to evaluate the extent of this effect in operating coal-fired boilers.

The initial 2001 field-testing was conducted at six coal-fired power plants. Four of the plants are equipped with SCR controls, one plant uses SNCR control, and one plant uses ammonia and sulfur trioxide for ash conditioning to improve particulate control. Field-testing was also conducted in 2002 at two of the 2001 SCR equipped plants and two additional plants with SCRs. An additional plant burning a Powder River Basin coal with an SCR is scheduled for testing in 2003. The field-testing included the use of both the manual Ontario Hydro method and SCEM's to measure the speciated mercury concentrations at the inlet and outlet of the SCRs to determine changes in the level of oxidized mercury.

Table 5 - SCR Mercury Speciation Results

	% Oxidized Mercury			
Plant Site	S1	S2	S3	S4
SCR Inlet	8%	48%	55%	9%
SCR Outlet	18%	91%	65%	80%

The results from the 2001 field-testing are mixed and demonstrate that, while oxidation of mercury across SCR systems can occur, the oxidation is a complex process that may be dependent on several variables such as coal properties, furnace combustion conditions, and SCR

catalyst factors including type, sizing, and age. Table 5 above presents a summary of the speciation data for the four plants with SCR.

Significant oxidation was shown to occur across the SCR for two of the four plants (S2 and S4). Of the two plants that did not show significant oxidation across the SCR, one burned Powder River Basin coal in a cyclone furnace (S1) and the other had a relatively small SCR (S3).^d Also, it appears that the SCR catalyst, rather than the ammonia, enhances the mercury oxidation. Testing at three of the four plants with SCR and two plants using SNCR and flue gas conditioning indicated that the ammonia injection did not significantly improve mercury oxidation. Interestingly, during operation of the Site S3 SCR without ammonia feed, the oxidized mercury further increased from 64% to 82% at the SCR outlet. Results from the 2002 field-testing have not yet been evaluated.¹³

Evaluation of Mercury Control Technologies for Utilities Burning Lignite Coal

UNDEERC is conducting a three-year, two-phase project to develop and test sorbent injection mercury control technologies for utilities that burn lignite coal. The project team includes EPRI and several electric utilities that operate lignite-fired plants. The first phase of the project, scheduled for 2002-2003, is to conduct bench-scale and pilot-scale evaluation for screening of potential sorbents. The second phase of the project, scheduled for 2003-2004, is to conduct full-scale field tests of the selected sorbents at a lignite-fired power plant.^e

The combustion flue gas of lignite-fired power plants primarily contains elemental mercury and therefore results in minimal mercury capture across the existing air pollution control equipment. Therefore, potential sorbents must be evaluated to develop a cost-effective sorbent injection control technology applicable to lignite-fired plants.

The bench- and pilot-scale testing is being conducted at UNDEERC. Initial bench-scale laboratory tests were conducted on 11 different sorbents using a fixed-bed reactor and simulated lignite coal combustion flue gas. In addition to commercially available activated carbons, several high-sodium lignite coals were used to produce activated carbons. An ARCADIS calcium silicate sorbent was also included in the bench-scale testing. The pilot-scale testing uses the 200 acfm UNDEERC particulate test combustor and is being conducted to compare the sorbent mercury capture effectiveness of an ESP, fabric filter, and the UNDEERC advanced hybrid particulate collector (AHPC). The pilot-scale testing is being conducted using two different lignite coals (Luscar and Freedom).

Test results indicated that the inactivated sorbents and calcium silicate were not effective. Based on the results of the bench-scale testing, the NORIT FGD and Luscar char-derived sorbents were selected for further pilot-scale testing. Results from the pilot-scale testing are currently being evaluated. An important lesson learned from the bench-scale testing is that mercury capture for carbon sorbents can be highly dependent on carbon activation temperatures. Under these test conditions, the carbon sorbents activated at 800°C performed significantly better than the same carbon sorbents activated at 750°C. The bench-scale testing also demonstrated the importance of hydrogen chloride in the flue gas, which apparently conditions the sorbents.¹⁴

^d The SCR space velocity at S3 is approximately 3900 hr⁻¹ compared to 1800 to 2300 hr⁻¹ for the other sites.

^e Saskatchewan Power has expressed interest in hosting the Phase II demonstration at the Poplar River Power Plant.

Mercury Control with the Advanced ElectroCore Particulate Collector

Under its particulate control program DOE/NETL is sponsoring the pilot-scale development of LSR Technologies' particulate control technology known as ElectroCore. In addition to DOE/NETL and LSR, the project team includes EPRI, EPA, and Alabama Power Company (Southern Company Services). The pilot-scale testing was conducted from November 2001 through February 2002. A final report on the mercury testing phase of the project is not yet available.

The ElectroCore is an electrically enhanced mechanical separator designed to be retrofitted downstream of an existing ESP to optimize fine particulate collection. The ElectroCore process first pre-charges the ash particles and then uses combined electrical and centrifugal forces to separate the flue gas into "dirty" and "clean" gas streams. The centrifugal particulate separation is achieved using cylindrical separators with a tangential inlet, a tangential dirty gas outlet, and a dual axial clean gas outlet. A schematic of a single cylindrical separator is shown in Figure 10. The centrifugal separation is enhanced by a centrally located electrode within the separator. The electrode is charged with the same polarity as the ash particles thereby further driving the particles to the dirty gas outlet. The dirty gas stream can either be re-circulated to the inlet of the upstream ESP or diverted to a polishing ESP or FF.

Figure 10 - Schematic of ElectroCore Cylindrical Separator.

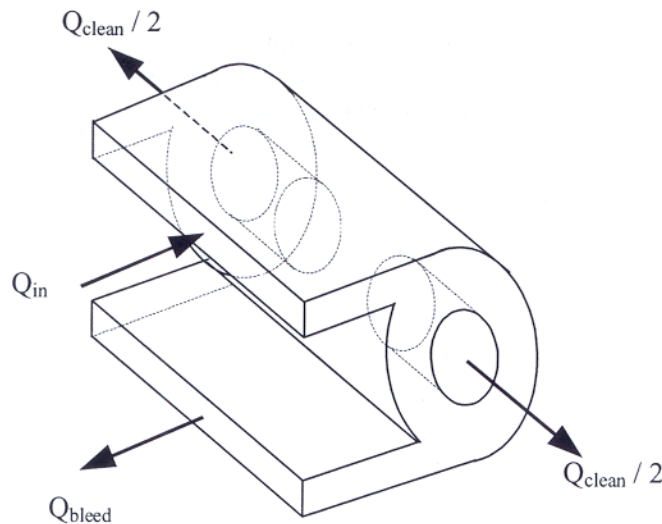

The pilot-scale testing was conducted at Alabama Power Company's E.C. Gaston Unit No. 4 located in Wilsonville, Alabama. The plant burns a Powder River Basin subbituminous coal. The 5,000 acfm pilot plant consists of a dry scrubber, water-cooled pre-charger, and advanced ElectroCore module. In addition to particulate removal, the mercury removal performance of the ElectroCore process was evaluated in conjunction with PAC injection. Preliminary test results indicate the ElectroCore process captures approximately 90% of the total mercury at a PAC injection rate of 7 lb/MMacf.¹⁵

In-House Mercury Control Technology R&D

An important component of DOE/NETL's mercury research program is its in-house R&D activities. Laboratory experimentation, modeling, and pilot-scale testing is being carried out in support of the overall goal of developing low-cost mercury control technology. In the laboratory-scale work, novel sorbents and techniques for the removal of mercury from flue gas are being investigated using a small packed-bed reactor. The reactor system is used to screen sorbents for their capability to remove mercury from gas streams, including both flue gas and fuel gas conditions. The capacities of these novel sorbents are determined as a function of gas composition and temperature and are compared to results with commercially available activated carbons.

In the pilot-scale work, a 500 pound-per-hour pulverized coal-fired combustion system that includes a furnace, air pre-heater, spray dryer, ductwork, and a pulse-jet fabric filter has been characterized with respect to the distribution and fate of hazardous air pollutants in flue gas, with an emphasis on mercury. Investigations with this unit have entailed evaluation of various activated carbons and novel sorbents, as well as comparisons of various sampling techniques for the determination of total and speciated forms of mercury while burning a low-sulfur bituminous coal. The most recent testing has included the use of a novel probe device, developed by Apogee Scientific, Inc., for measuring vapor-phase mercury in the presence of fly ash and/or an active mercury sorbent to determine in-duct removals. The sorbent injection tests have been expanded to include flue gas, and the resulting mercury speciation, from the combustion of a subbituminous PRB coal. In order to provide insight into the data obtained from the pilot-scale system, a two-stage mathematical model using powdered activated carbon has been developed. The model accounts for mercury removal in the ductwork with additional removal in the particulate collection device (baghouse).

As a result of the research described above, the following two novel DOE/NETL processes show promise as cost effective methods for mercury control.

In-Situ Sorbent Removal of Mercury: The THIEF Process

The THIEF process (U.S. Patent No. 6,521,021) removes mercury from coal combustion flue gas by adsorption/absorption onto thermally activated sorbent produced in-situ. The sorbent consists of semi-combusted coal, which is extracted from the furnace and then injected into the flue gas downstream of the air preheater. The thermally activated sorbent reacts with the mercury and is removed from the flue gas by the downstream particulate control device. The in-situ produced sorbent is not as reactive as commercially available activated carbon, but pilot-scale testing indicates that mercury removal efficiencies of up to 70% are achievable. Table 6 shows the test results for various sorbent injection feed rates using Evergreen low-sulfur bituminous coal.¹⁶ Continued testing of the THIEF process will be carried out in the 500-lb/hr combustor while burning different coals (i.e. PRB coal).

Table 6 - THIEF Sorbent Injection Test Results

Test	Average Inlet Mercury Concentration, $\mu\text{g}/\text{dncm}$	Sorbent-to-Mercury Injection Ratio, g/g	Mercury Removal, %
Test 1: Baseline	11.0	0	18.0
Test 1: Evergreen	11.4	17,500	60.2
Test 2: Baseline	8.6	0	16.0
Test 2: Evergreen	8.7	10,500	26.8
Test 2: Evergreen	9.4	23,500	62.8
Test 2: Evergreen	6.8	51,600	76.4

Photochemical Removal of Mercury: The GP-254 Process

A new method that may enhance mercury removal from coal-fired power plant combustion flue gas in existing air pollution control devices has been developed at DOE/NETL. Dubbed the GP-254 process (U.S. patent pending), the system uses 253.7-nm ultraviolet radiation and simple equipment similar to that used in water treatment plants for the eradication of microbes. Irradiation with 253.7-nm light can induce many components of flue gas to react with elemental mercury and subsequently cause an increase in the fraction of oxidized mercury. The oxidized mercury species can then be captured near the radiation zone or in downstream particulate control or wet FGD pollution control equipment. Small-scale laboratory testing using simulated flue gases have been used to demonstrate the process. A preliminary cost analysis suggests that annual operating costs for the GP-254 process could compete with activated carbon injection systems.¹⁷

Computational Fluid Dynamics Modeling

A Computational Fluid Dynamics (CFD) modeling effort was initiated in 2002 by DOE/NETL's in-house staff to develop additional insight into effective control strategies for mercury. Models for mercury speciation and adsorption are being integrated into a CFD framework to help predict the in-flight capture of mercury from flue gases. The gas/particle flow simulations predict the residence time and temperature history of the sorbent particles and provide input for mercury adsorption models. A range of laboratory through utility-scale data will be used to validate the models.

Impact of Mercury Capture on Coal Utilization By-Products

There is a concern that the mercury captured in coal utilization by-products (CUBs), such as fly ash and FGD solids, could be re-emitted into the environment during either disposal or utilization. DOE/NETL is sponsoring a number of projects that focus on an evaluation of the potential leaching and volatilization of mercury and other trace metals from coal by-products.

CONSOL Energy is conducting an extensive evaluation of the CUBs from 14 coal-fired power plants. The plants represent a range of coal ranks and APCD configurations. The evaluation includes leaching and volatilization tests of bottom ash, fly ash, wet and dry FGD scrubber solids, and products from activated carbon injection tests. Testing is also being conducted on products made from CUBs such as cement, gypsum wallboard, and manufactured aggregates. Preliminary results indicate that at most a minimal amount of mercury is leached from the CUBs with less than 1 ppb of mercury detected in all of the leachate samples. Results from the volatilization testing are not yet available.¹⁸

UNDEERC is carrying out an evaluation of the potential release of mercury and other air toxic elements associated with the disposal and commercial use of coal utilization by-products. Laboratory and field-testing will be conducted on various ash and FGD CUBs from conventional and advanced pollution control systems. CUBs from bituminous, subbituminous, and lignite fuels will be included in the evaluation. The potential release mechanisms to be evaluated include leaching, vaporization at ambient and elevated temperature, and biologically induced releases. The three-year project will be completed by December 2005.

EPRI is conducting a three-year investigation of the potential for groundwater impacts of arsenic, selenium, and mercury leaching from CUBs. Leachate sampling and testing will be conducted at approximately 25 active or closed CUB disposal sites. Three of the disposal sites will be selected for more detailed field investigations of arsenic and selenium leaching and attenuation. The project is scheduled for completion by September 2005.

DOE/NETL also conducts in-house R&D on the potential impacts of mercury and other metals on the utilization and disposal of CUBs. The overall goal of the in-house research effort is provide an unbiased source of data on the environmental implications of coal by-products and to develop new applications to promote diversified utilization. The in-house group is conducting extensive long-term leaching tests to quantify the release of mercury and other heavy metals from a random population of CUBs. Based on the long-term results, a short-term leaching test will be developed and validated that can be used by industry and state regulatory agencies to inexpensively design appropriate coal by-product management strategies.

In addition, DOE/NETL sponsors the Combustion By-Products Recycling Consortium (CBRC) that conducts research “to promote the beneficial recycling of coal combustion by-products through scientific research for the protection of the environment.” The CBRC projects include evaluation of the environmental impacts of mercury as well as other hazardous pollutants that may be present in trace quantities in CUBs.

Transport and Fate of Mercury Emissions from Coal-Fired Power Plants

The majority of DOE/NETL mercury research is directed at the development of control technologies and evaluation of the environmental impact of captured mercury in CUBs. However, DOE/NETL is also sponsoring research to evaluate the transport and fate of mercury emissions from coal-fired power plants. For example, DOE/NETL is supporting a wet deposition monitor located near Holbrook, Greene County, Pennsylvania as part of the national Mercury Deposition Network. The proportions of elemental and oxidized species of mercury emissions from coal-fired power plants may influence the relative location of their potential environmental impact. Gaseous elemental mercury is relatively unreactive and can persist in the atmosphere for periods of months to years before returning to the surface environment. However, gaseous oxidized mercury is more reactive and likely to return to the surface environment locally or regionally via wet or dry deposition. The speciation of mercury emissions from coal-fired power plants may prove important in the policy debate concerning the role of plant-by-plant mercury reductions versus national or regional emission cap and trade programs. Based on estimates derived from the EPA ICR data, the average mercury speciation for coal-fired power plants is 3% particulate-bound, 54% elemental and 43% oxidized as measured in the stack.³ However, atmospheric reactions might occur after release from the stack that alters the proportion of elemental and oxidized mercury species. If oxidized mercury is reduced to elemental mercury within the stack plume, there should be less concern with local “hot spots” of mercury deposition and perhaps less environmental objections to a mercury emissions trading program.

DOE/NETL and EPRI are co-sponsoring two projects to characterize the speciation of mercury in the stack plumes of coal-fired power plants. The two plants being tested are Southern Company’s Bowen Plant and We Energies’ Pleasant Prairie Plant. The Bowen Plant testing was completed in October 2002 and the Pleasant Prairie testing is scheduled to be completed in May 2003. Results of the Bowen Plant testing are not yet available.

The tests, which will be performed by UNDEERC, include simultaneous mercury measurements in the stack and stack plume using aircraft and/or balloon-borne instruments. The in-stack and stack plume measurements will be compared to determine whether the speciation of mercury changes as it is transported downwind in the plume. Previous analysis of mercury concentrations measured at an ambient monitor located about 15 km south of the Bowen Plant suggested that a significant portion of Bowen’s oxidized mercury stack emissions may have been reduced to elemental mercury while being transported to the monitoring site.

In addition to the in-stack and stack plume mercury measurements, a plume dilution sampling device is being used in an attempt to simulate the cooling and dilution processes that occur in the stack plume. If results of the plume dilution sampling device are comparable to the stack plume measurements it could be used to estimate the mercury speciation changes for other plants.

New DOE/NETL Mercury Control Technology R&D Projects

Several new mercury control technology R&D projects will be initiated in 2003:

- ADA-ES will conduct a one-year long-term performance evaluation of the impact of powdered activated carbon injection on the COHPAC fabric filter particulate collection system at Alabama Power's E.C. Gaston Plant. As discussed above, ADA-ES conducted a successful two-week demonstration of PAC injection at Gaston in April 2001. The objective of this project is to evaluate the long-term effects of PAC injection on mercury capture and COHPAC performance. Of particular concern during PAC injection is the increased cleaning frequency of the COHPAC which could adversely affect filter bag life. The long-term testing will include six-month PAC injection with the existing COHPAC filter bags and six-month PAC injection with new high-permeation filter bags. Testing is scheduled to begin in March 2003.
- General Electric Energy and Environmental Research Corporation (GE EER) will conduct a two-year field evaluation using a combination of overfire air (OFA) and coal reburn to achieve multi-pollutant control of both NO_x and mercury. The field-testing will be conducted at Western Kentucky Energy's RD Green Power Station, which burns a blend of Illinois bituminous coal and petroleum coke. Field measurements of fly ash properties and mercury removal across the ESP will be taken on Unit No. 1 after installation of an OFA and coal reburn system for NO_x control. Data from the Unit No. 1 field testing will be used to optimize the design of the NO_x control system for mercury removal using a 300 KW pilot-scale combustor at GE EER's test facility. Results from the pilot-scale testing will be used for the design of the OFA and coal reburn system to be installed on RD Green Unit No. 2. Mercury removal performance will then be tested on Unit No. 2 after installation of the optimized NO_x control system.
- CONSOL will conduct mercury speciation field-testing at ten bituminous coal-fired power plants equipped with both SCR and FGD systems. The objective of the study is to measure the level of mercury oxidation across the SCR and subsequent removal in the downstream FGD system. The 27-month long program will include testing at five plants equipped with an SCR and wet limestone FGD, three plants with an SCR and wet lime FGD, and two plants with an SCR and dry lime FGD.
- Reaction Engineering will conduct a six-month-long pilot-scale mercury speciation test for several NO_x SCR catalysts using a flue gas slipstream at AEP's Rockport Power Plant, which burns a subbituminous Powder River Basin coal. Parametric testing will evaluate the effect of space velocity (residence time) and ammonia feed rate on mercury oxidation across the SCR catalysts.

Summary

The DOE/NETL mercury control technology research program has helped to advance the understanding of the formation, distribution, and capture of mercury from coal-fired power plants. Some general observations can be drawn from the results of the mercury control technology research that has been carried out to date:

- (1) Coal properties, such as chlorine content, can impact the potential mercury capture performance of various mercury control technologies.
- (2) Mercury capture with PAC injection has been successfully demonstrated in short-term applications. However, the range of effectiveness depends on coal type and plant configuration. More long-term evaluation is necessary to determine realistic cost and performance estimates for various plant arrangements.
- (3) The co-benefit capture of oxidized mercury by wet FGD systems has been successfully demonstrated. However, potential reduction of a portion of the oxidized mercury to elemental mercury within the wet FGD absorber may reduce overall capture in some applications.
- (4) Although mercury oxidation across NO_x SCR has been demonstrated, it appears to be highly variable depending on coal properties and SCR catalyst factors including type, sizing, and age.
- (5) For all of the mercury control technologies, uncertainties remain regarding the capture effectiveness with various coal-rank and existing pollution control device configurations, balance-of-plant impacts, and by-product use and disposal.
- (6) The accuracy and precision of mercury measurements using both the manual wet chemistry Ontario Hydro method and several different mercury CEMs have demonstrated significant variability and complicate drawing conclusions from the limited field-testing conducted to date.
- (7) Although improvements are being made, mercury CEMs have not yet demonstrated long-term reliability necessary for use as regulatory compliance tools.
- (8) Significant variability in mercury capture co-benefits of existing APCD has been observed at similar units as well as at individual units tested at different times.

Conclusion

While our knowledge of the formation, distribution, and capture of mercury from coal-fired power plants has greatly advanced over the past decade, many uncertainties and challenges remain. Moreover, there are no commercial technologies available today to effectively remove mercury from the diverse population of coal-fired power plant currently in operation. Therefore, as the Nation moves toward regulating mercury emissions from the electric-utility sector, it is critical that research continues to address these challenges.

In response, DOE/NETL is continuing to partner with industry and other key stakeholders in carrying out a comprehensive mercury control technology R&D program. This effort is being carried out through both extramural and in-house research focused on (1) enhancing the capture of mercury across existing APCDs, and (2) developing novel standalone control concepts to achieve high levels of mercury removal at costs considerably lower than current technology. In

addition, the program includes more fundamental research directed at understanding the fate of mercury in the by-products from coal combustion, such as fly ash and scrubber solids, as well the emission, transformation, and transport of mercury from coal-based power systems.

DOE/NETL is committed to continue its comprehensive mercury control technology research program to improve performance and reduce costs to enable the existing fleet of coal-fired power plants to reliably and cost effectively comply with future mercury control regulations, while also providing the scientific and technical knowledge needed to help craft sound regulatory policy.

Acknowledgments

This report would not have been possible without the efforts of the DOE/NETL project managers and researchers who provided valuable technical input. The authors would like to acknowledge the contribution of Lynn Brickett, Bill Aljoe, Bruce Lani, Jose Figuera, Bob Patton, Barbara Carney, Peter Botros, Swenam Lee, Evan Granite, Henry Pennline, and Bill O'Dowd. The authors further acknowledge the support and input provided by Doug Carter and Denny Smith from DOE's Office of Fossil Energy.

References

¹ U.S. EPA *Mercury Study Report to Congress*, EPA-452/R-97-003, December 1997.

² United Nations Environment Programme (UNEP), *Global Mercury Assessment*, UNEP Chemicals, Geneva, Switzerland, December 2002.

³ Research Triangle Institute. National Mercury Emission Inventory Database, June 2001.

⁴ U.S. EPA *Control of Mercury Emissions from Coal-Fired Electric Utility Boilers: Interim Report Including Errata Dated 3-21-02*, EPA-600/R-01-109, April 2002.

⁵ Bustard, C. Jean; Durham, Michael; Lindsey, Charles; Starns, Travis; Baldrey, Ken; Martin, Cameron; Schlager, Richard; Sjostrom, Sharon; Slye, Rick; Monroe, Larry; Miller, Richard; Chang, Ramsey Full-Scale Evaluation of Mercury Control with Sorbent Injection and COHPAC at Alabama Power E.C. Gaston. Presented at the A&WMA Specialty Conference on Mercury Emissions: Fate, Effects, and Control and the US EPA/DOE/EPRI Combined Power Plant Air Pollutant Control Symposium: Mega Symposium, Chicago, IL, August 2001.

⁶ Bustard, Jean; Durham, Mike; Starns, Travis; Lindsey, Charles; Martin, Cameron; Schlager, Richard; Baldrey, Ken Full-Scale Evaluation of Sorbent Injection for Mercury Control on Coal-Fired Power Plants. In *Proceedings of Air Quality III: Mercury, Trace Elements, and Particulate Matter Conference*; Arlington, VA, September 9-12, 2002.

⁷ Babcock & Wilcox Company and McDermott Technology, Inc. Full-Scale Testing of Enhanced Mercury Control Technologies for Wet FGD Systems. Final report to the U.S. Department of Energy under Contract No. DE-FC26-00NT41006, August 30, 2002.

⁸ Miller, Stanley; Zhuang, Ye; Rinschler, Craig; Gebert, Rich; Davis, Dwight; Swanson, William Mercury Control with the Advanced Hybrid. In *Proceedings of Air Quality III: Mercury, Trace Elements, and Particulate Matter Conference*; Arlington, VA, September 9-12, 2002.

⁹ McLarnon, Christopher Mercury Removal in a Multi-Pollutant Control Technology for Utility Boilers. In *Proceedings of Air Quality III: Mercury, Trace Elements, and Particulate Matter Conference*; Arlington, VA, September 9-12, 2002.

¹⁰ Southern Research Institute Mercury Control with Calcium-Based Sorbents and Oxidizing Agents. Progress report to the U.S. Department of Energy under Contract No. DE-FC26-01NT41183, June 2002.

¹¹ Blythe, Gary; Richardson, Carl; Rhudy, Richard Pilot Evaluation of the Catalytic Oxidation of Mercury for Enhanced Removal in Wet FGD Systems. In *Proceedings of Air Quality III: Mercury, Trace Elements, and Particulate Matter Conference*; Arlington, VA, September 9-12, 2002.

¹² URS Corporation Pilot Testing of Mercury Oxidation Catalysts for Upstream of Wet FGD Systems. Progress report to the U.S. Department of Energy under Contract No. DE-FC26-01NT41185, January 21, 2003.

¹³ EPRI. *Power Plant Evaluation of the Effect of Selective Catalytic Reduction in Mercury*; EPRI Report No. 1005400; December 2002.

¹⁴ UNDEERC Mercury Control Technologies for Utilities Burning Lignite Coal. Progress report to the U.S. Department of Energy under Contract No. DE-FC26-98FT40321, August 2002.

¹⁵ Altman, Ralph; Easom, Bruce; Harrison, Wallace Results of ElectroCore Pilot Testing at E.C. Gaston Steam Plant. In *Proceedings of Air Quality III: Mercury, Trace Elements, and Particulate Matter Conference*; Arlington, VA, September 9-12, 2002.

¹⁶ Pennline, H.W.; Granite, E.J.; Freeman, R.A.; Hargis, R.A.; O'Dowd, W.J. A Technique to Control Mercury From Flue Gas. Presented at the AIChE Annual Meeting, Indianapolis, IN, November 2002.

¹⁷ Granite, Evan; Pennline, Henry Photochemical Removal of Mercury from Flue Gas. *Industrial & Engineering Chemistry Research*, October 2002.

¹⁸ Withum, Jeffrey; Schwalb, Allyson; Statnick, Robert Characterization of Coal Combustion By-Products for the Re-Evolution of Mercury into Ecosystems. In *Proceedings of Air Quality III: Mercury, Trace Elements, and Particulate Matter Conference*; Arlington, VA, September 9-12, 2002.