



US006745061B1

(12) **United States Patent**
Hicks et al.

(10) **Patent No.:** **US 6,745,061 B1**
(45) **Date of Patent:** **Jun. 1, 2004**

- (54) **DISPOSABLE OXIMETRY SENSOR**
- (75) **Inventors:** **Christopher Hicks**, Boulder, CO (US);
Norma M. Prince, Lyons, CO (US)
- (73) **Assignee:** **Datex-Ohmeda, Inc.**, Madison, WI (US)
- (*) **Notice:** Subject to any disclaimer, the term of this patent is extended or adjusted under 35 U.S.C. 154(b) by 0 days.

5,671,529 A	9/1997	Nelson	29/825
5,678,544 A	10/1997	DeLonzor et al.	
5,782,757 A *	7/1998	Diab et al.	600/323
RE36,000 E	12/1998	Swedlow et al.	
5,913,819 A	6/1999	Taylor et al.	600/323
6,014,576 A	1/2000	Raley	600/344
6,073,038 A	6/2000	Wang et al.	600/323

* cited by examiner

Primary Examiner—Eric F. Winakur
(74) *Attorney, Agent, or Firm*—Marsh Fischmann & Breyfogle LLP

- (21) **Appl. No.:** **10/225,940**
- (22) **Filed:** **Aug. 21, 2002**
- (51) **Int. Cl.⁷** **A61B 5/00**
- (52) **U.S. Cl.** **600/344; 600/323**
- (58) **Field of Search** **600/310, 322, 600/323, 340, 344**

(57) **ABSTRACT**

The invention is directed to a disposable oximetry sensor having an integrally formed connector. In one aspect, the sensor includes a clear flexible substrate on which a light emitter and/or light detector (collectively active component (s)) are mounted to allow those components to emit/detect light though the clear substrate and a second patient-side surface of that substrate. The clear substrate will generally contain one or more electrically conductive traces, preferably formed through a printing process, for interconnection to the active components. In this regard, the clear substrate acts as the electrical connector and lens structure for the active components reducing the overall part count for the sensor's assembly. Additional materials/layers may be added to the sensor including an adhesive layer, a compressible material layer, a light blocking layer, and/or a heat sink for thermal management. Generally, any additional layers/materials applied the patient-side of the clear substrate will be substantially transparent to allow light curing of adhesives utilized to connect components to the sensor though the patient-side surface of the sensor during production.

- (56) **References Cited**
- U.S. PATENT DOCUMENTS**
- 4,825,872 A 5/1989 Tan et al.
- 4,830,014 A 5/1989 Goodman et al.
- 4,865,038 A 9/1989 Rich et al.
- 4,964,408 A 10/1990 Hink et al.
- 5,041,187 A 8/1991 Hink et al.
- 5,237,994 A 8/1993 Goldberger
- 5,246,003 A 9/1993 DeLonzor
- 5,249,576 A 10/1993 Goldberger et al.
- 5,263,244 A 11/1993 Centa et al.
- 5,425,360 A 6/1995 Nelson
- 5,427,093 A * 6/1995 Ogawa et al. 600/323
- 5,452,717 A 9/1995 Branigan et al.
- 5,469,845 A 11/1995 DeLonzor et al.
- 5,520,177 A 5/1996 Ogawa et al.

34 Claims, 13 Drawing Sheets

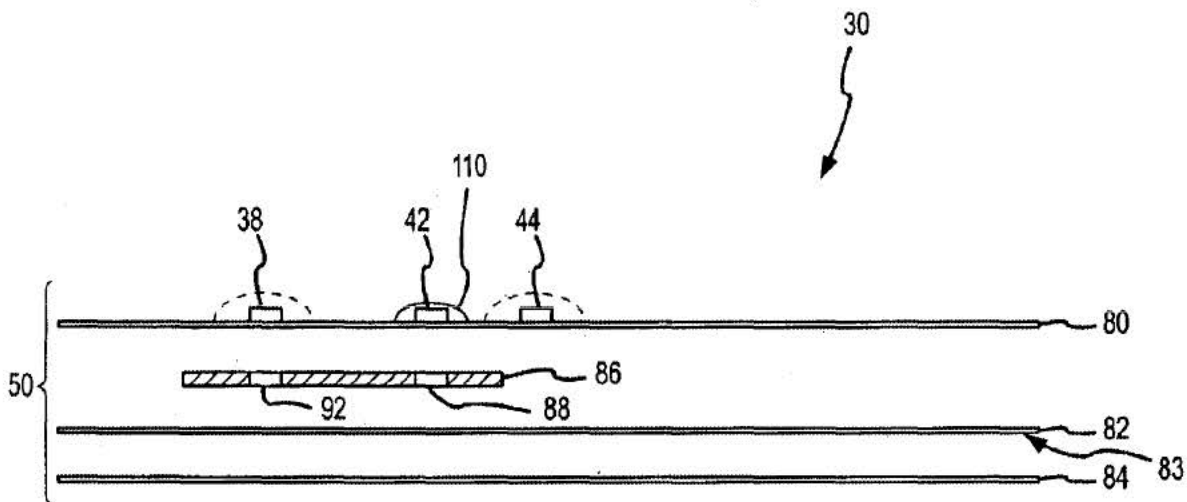

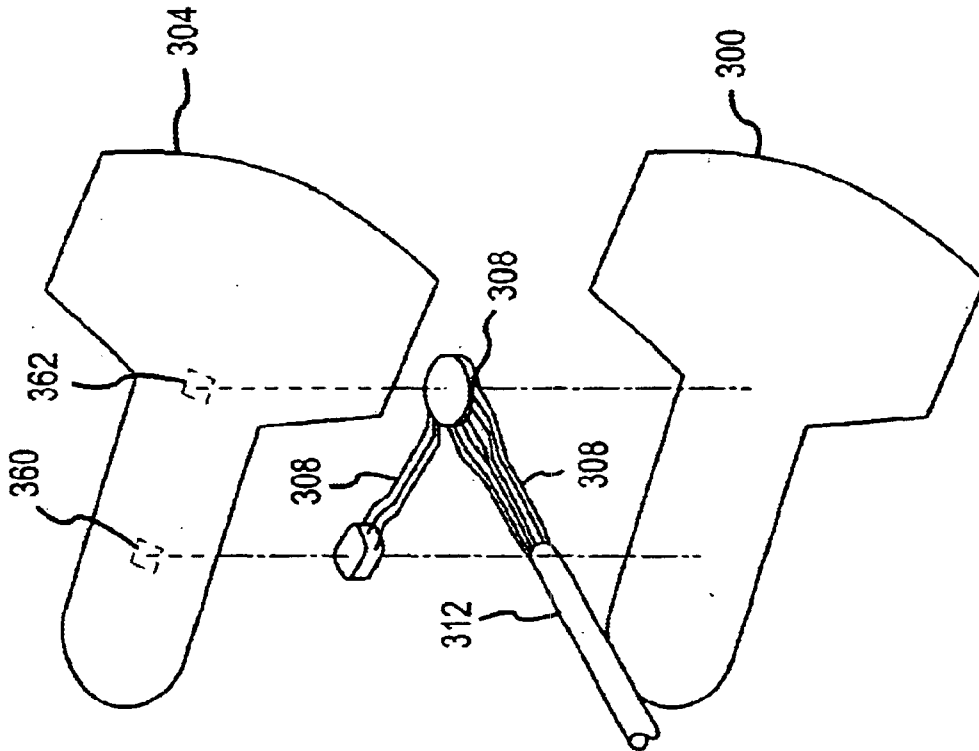

(PRIOR ART)
FIG. 1

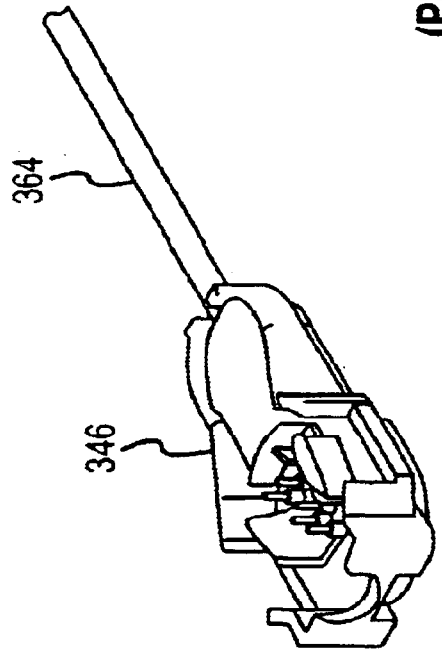

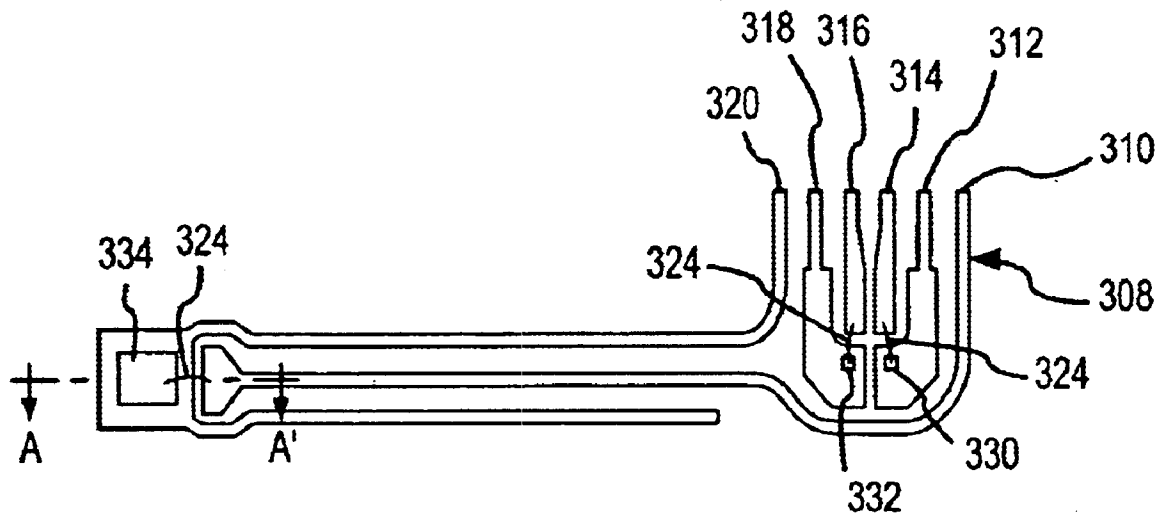

(PRIOR ART)
FIG.2

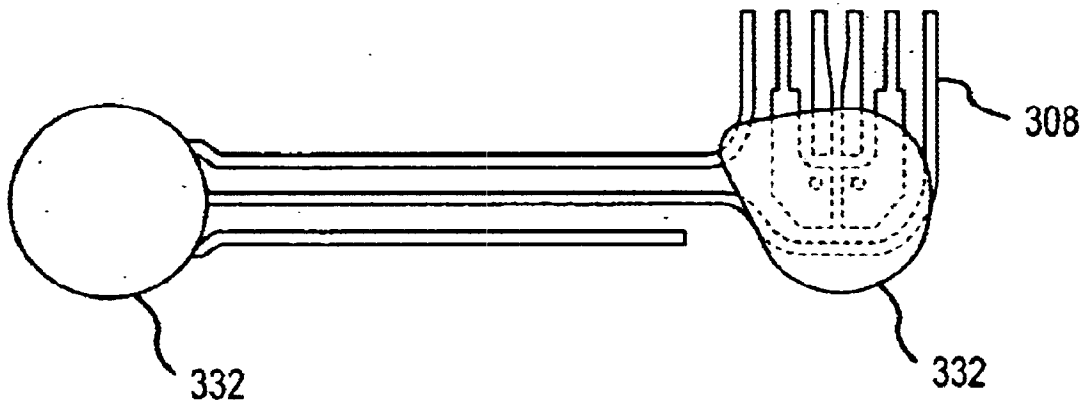

(PRIOR ART)
FIG.4

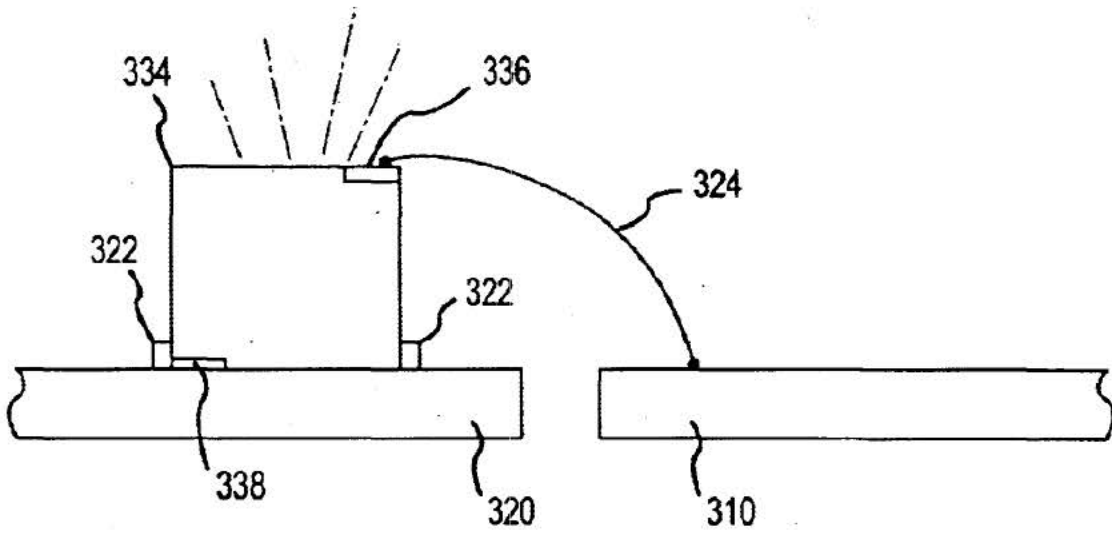

(PRIOR ART)

FIG.3

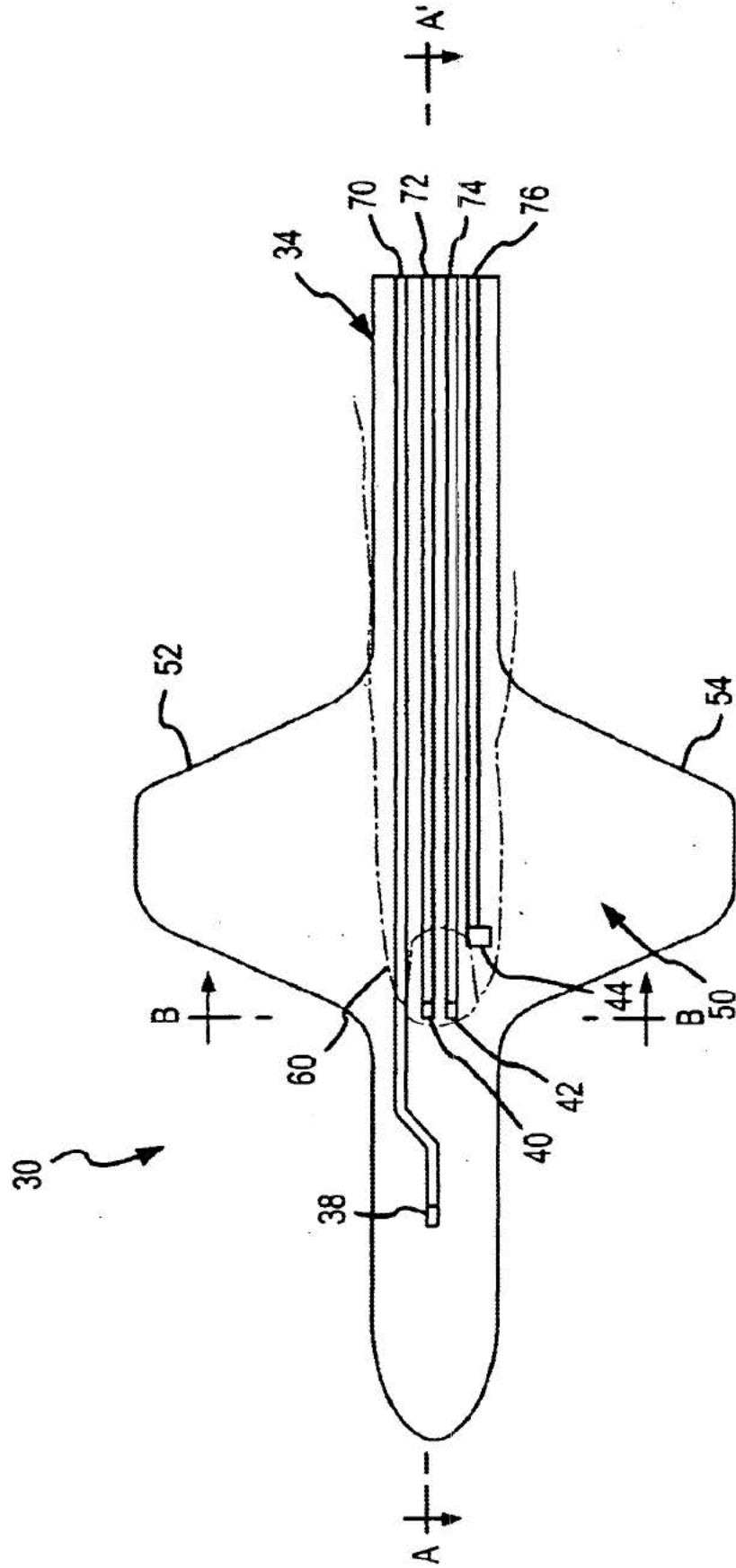

FIG. 5

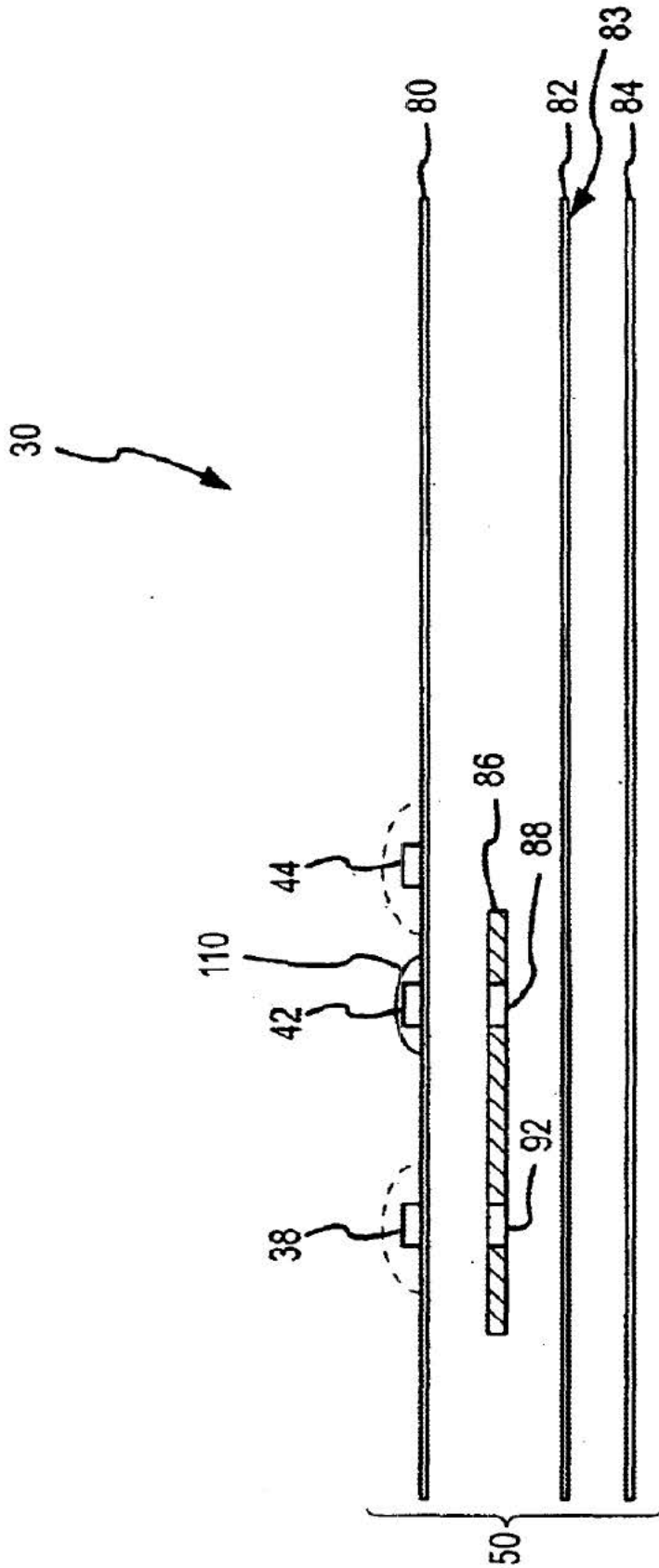

FIG. 6

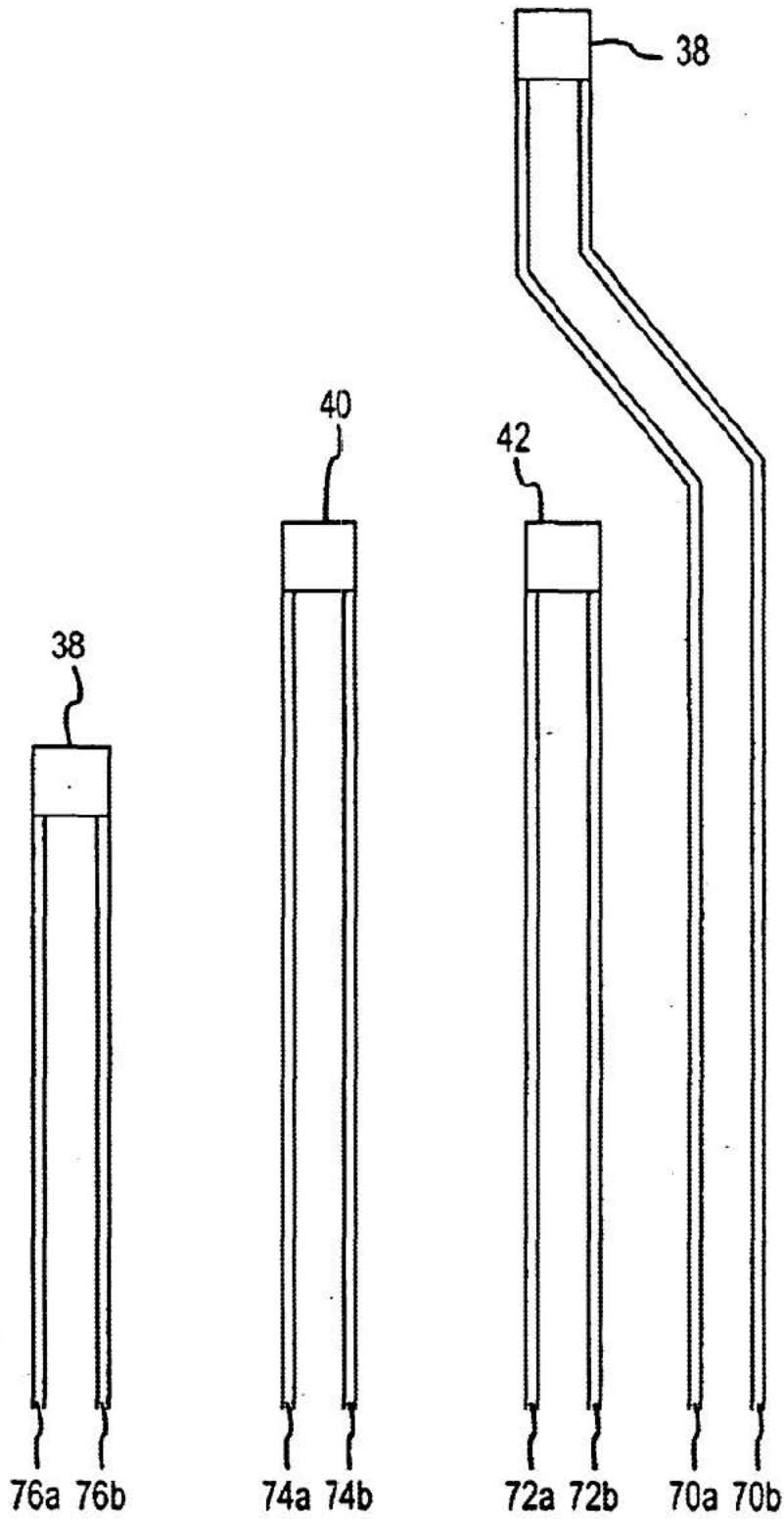

FIG. 7

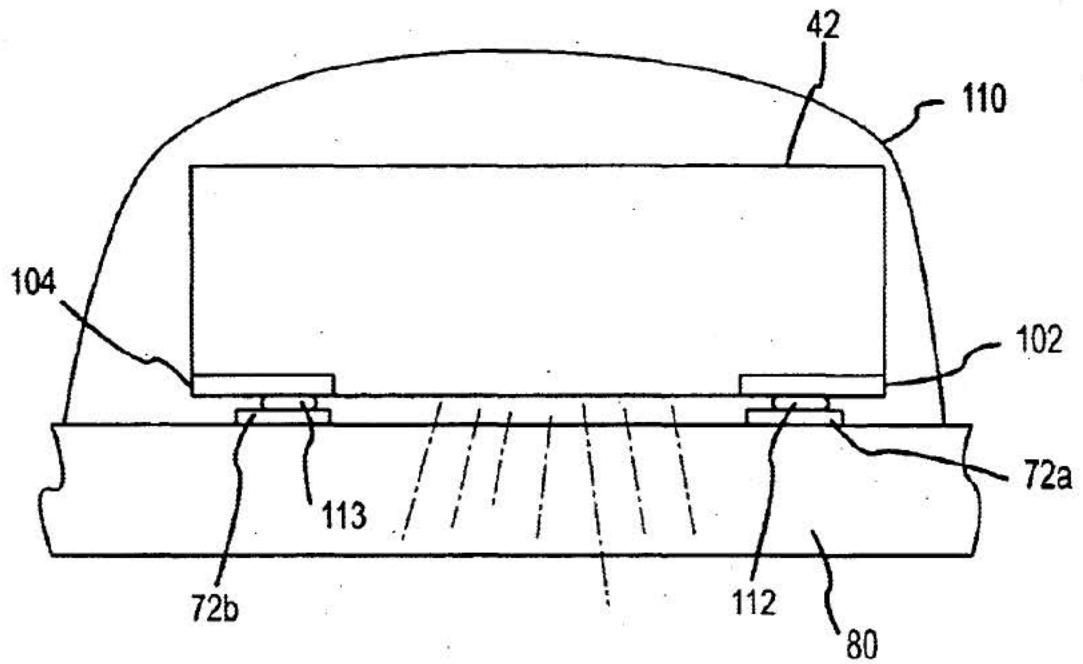

FIG. 8a

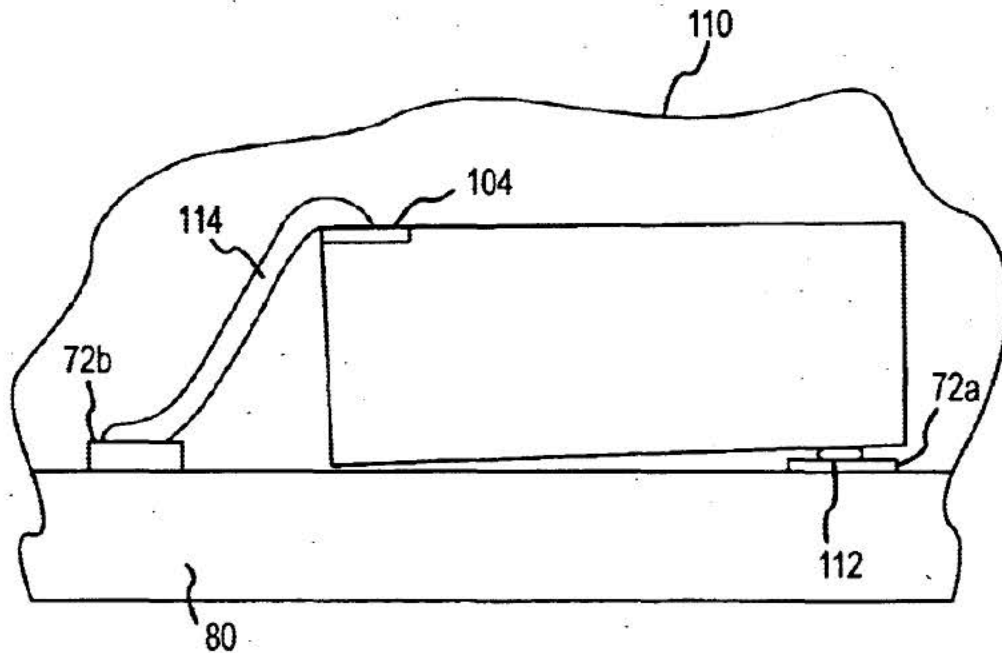

FIG. 8b

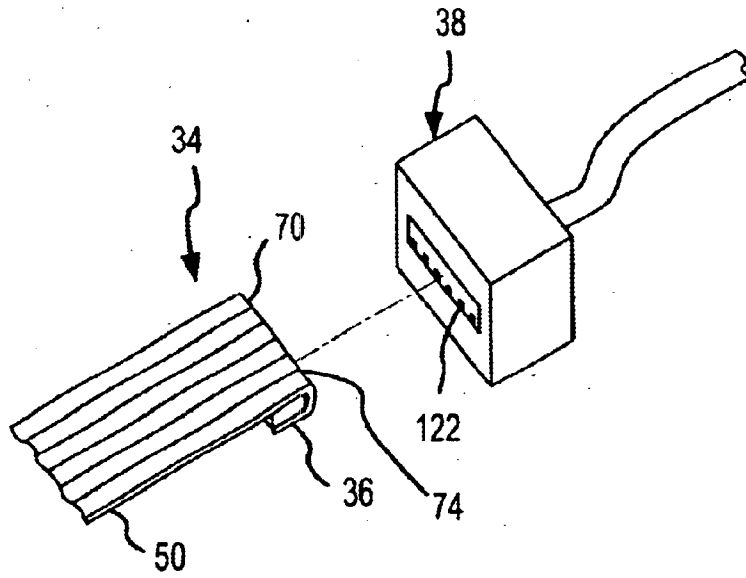

FIG. 9

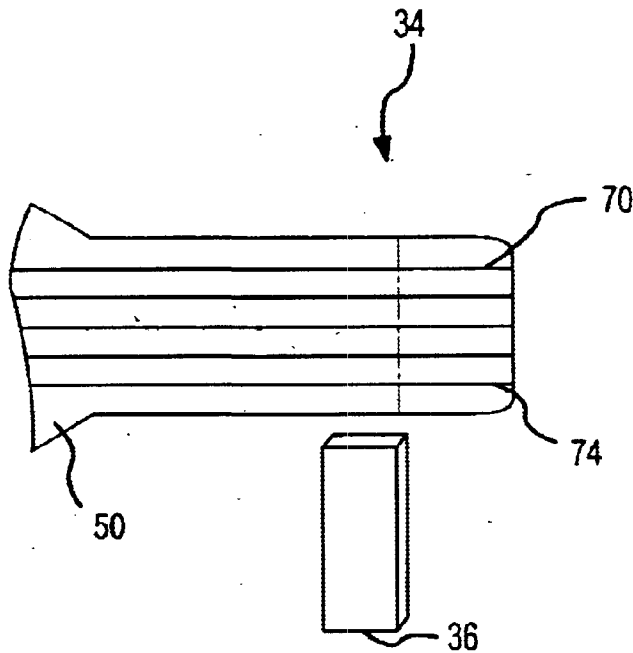

FIG. 10

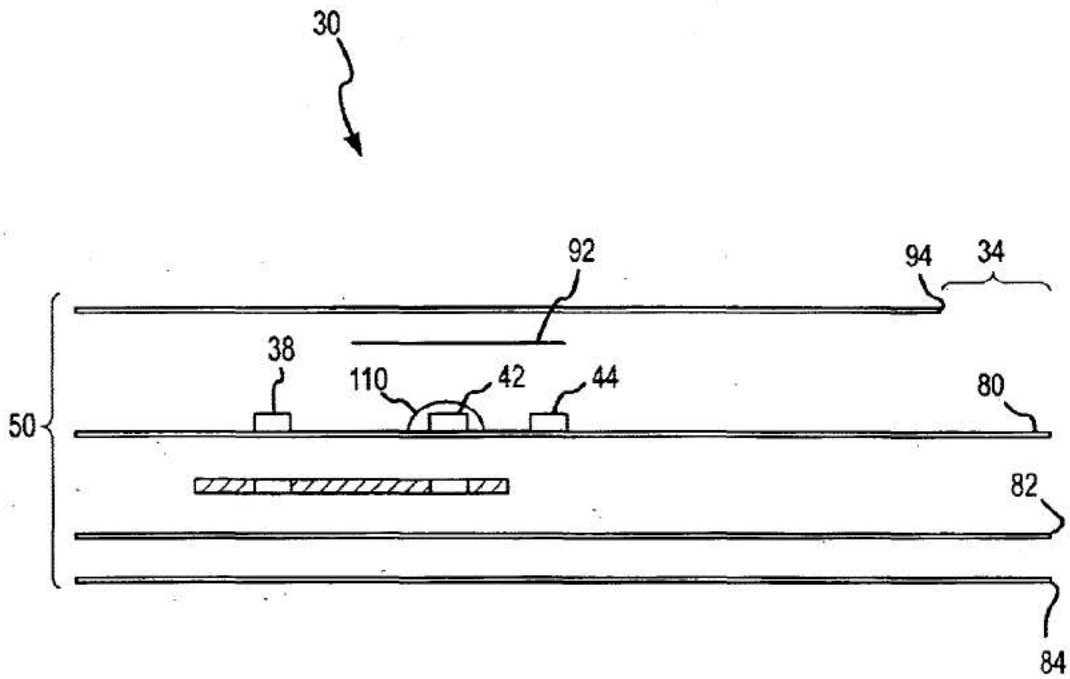

FIG.11

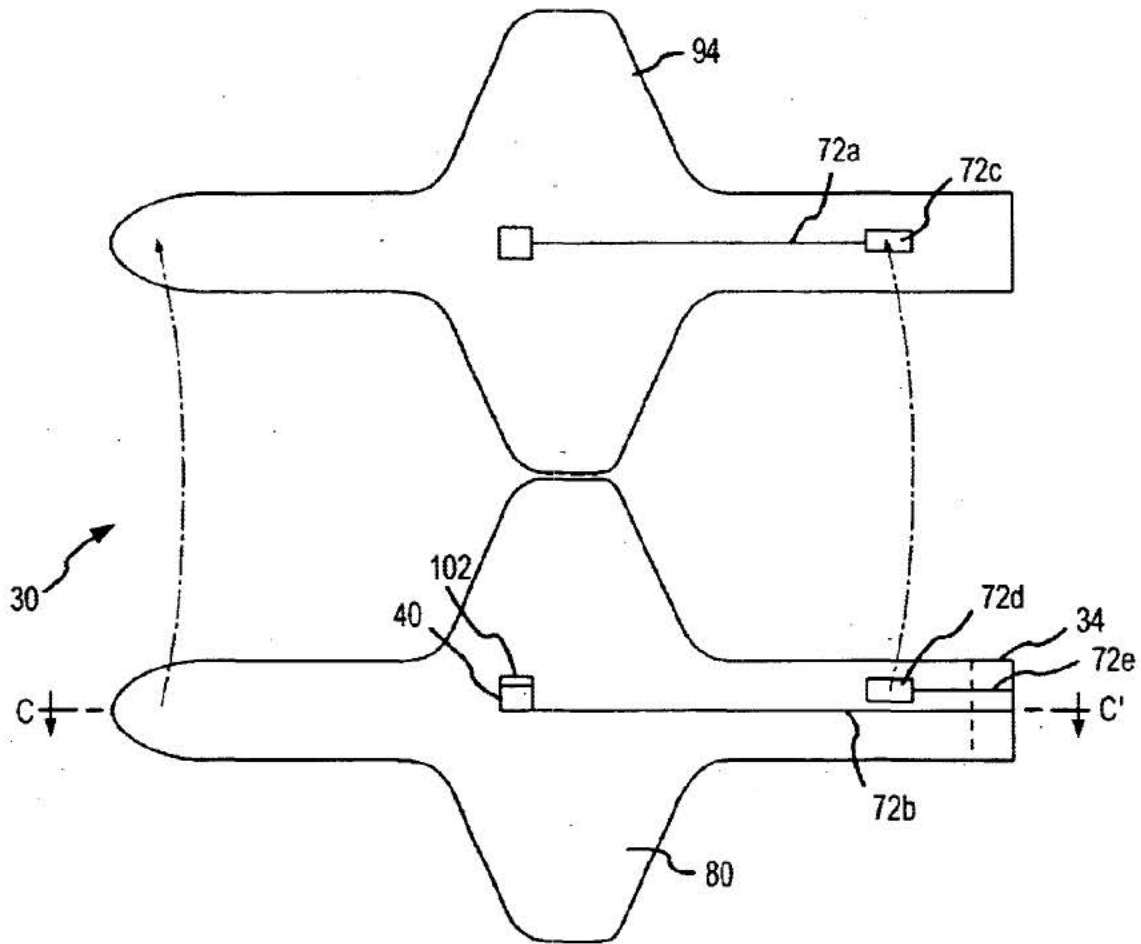

FIG. 12

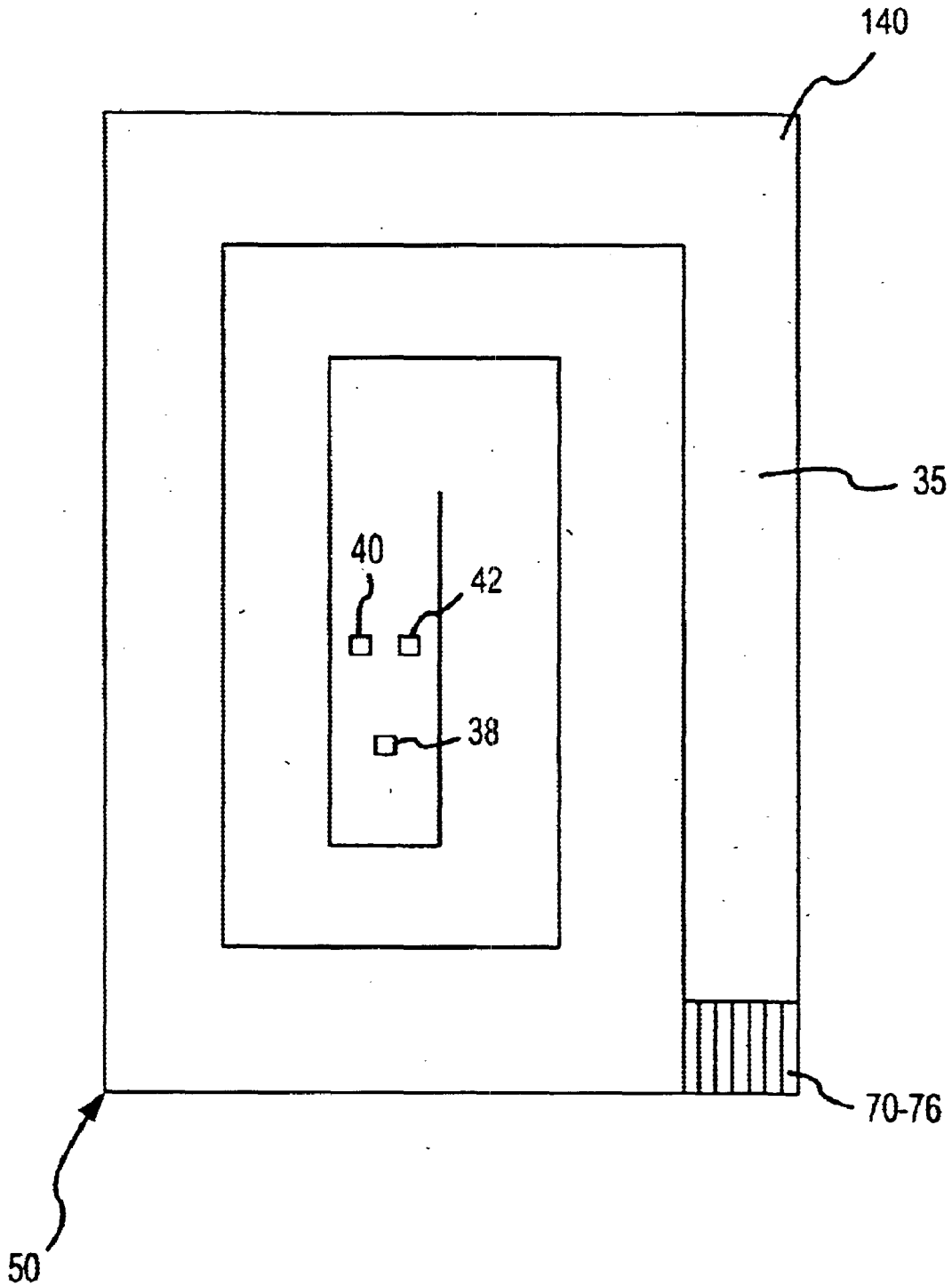

FIG. 13

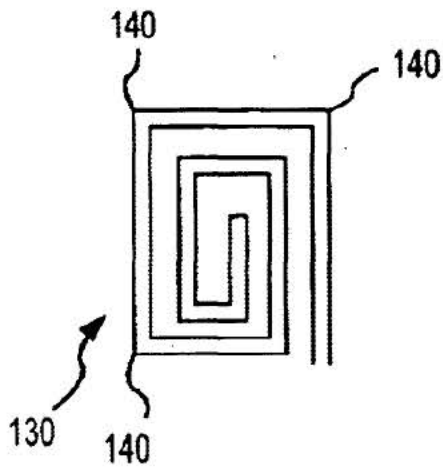

FIG. 14a

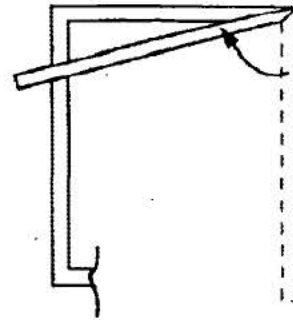

FIG. 14b

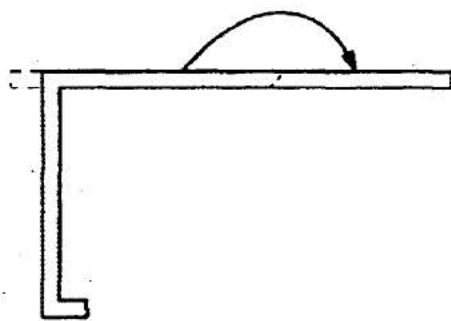

FIG. 14c

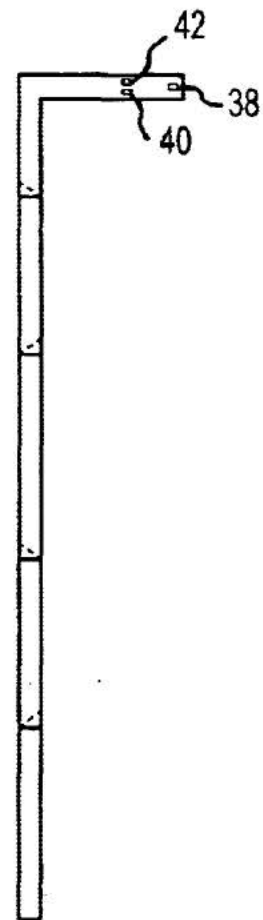

FIG. 14d

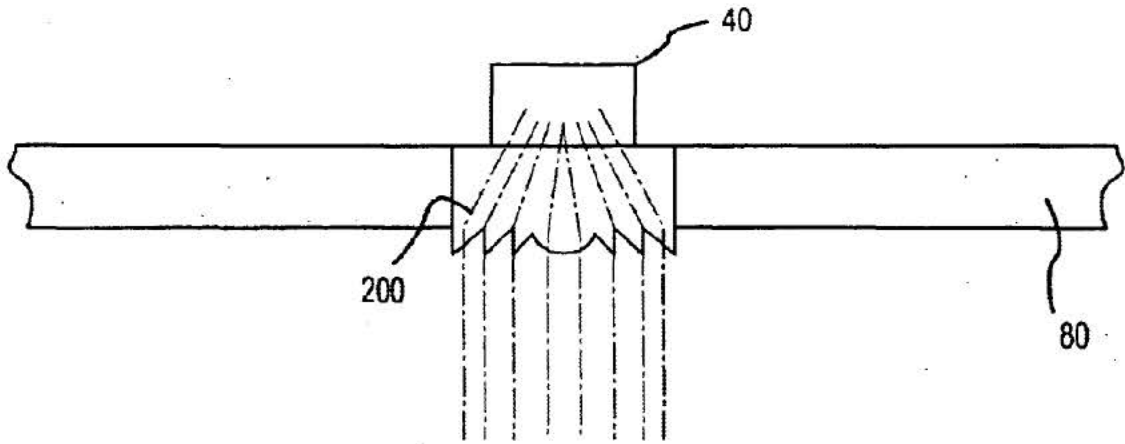

FIG.15

DISPOSABLE OXIMETRY SENSOR**FIELD OF THE INVENTION**

The present invention is generally directed to photopl- 5
ethysmographic measurement instruments, and more specifically to disposable pulse oximetry sensors.

BACKGROUND

A common technique used to monitor blood oxygen levels 10
is pulse oximetry. In this regard, it is known that the light transmissivity and color of blood is a function of the oxygen saturation of the heme in the blood's hemoglobin. For example, heme that is saturated with oxygen appears bright 15
red because saturated heme is relatively permeable to red light. In contrast, heme that is deoxygenated appears dark and bluish as it is less permeable to red light. A pulse oximeter system measures the oxygen content of arterial blood by utilizing a pulse oximetry sensor to first illuminate 20
the blood with, for example, red and infrared radiation and determine the corresponding amounts of red and infrared radiation that are absorbed by the heme in the blood. In turn, such light absorption amounts may be employed by a pulse oximetry monitor in conjunction with known calibration information to determine blood oxygen levels. 25

Pulse oximetry sensors generally include one or more light emitters, a detector(s), and a means for holding these components relative to a patient's tissue. These sensors may generally be classified as reusable or disposable. Reusable 30
sensors typically are more intricate and designed for multiple uses on multiple patients. In this regard, reusable sensors generally must be cleaned between use on different patients. Disposable sensors are typically simplified sensors that are used for a predetermined period on a single patient and discarded. Accordingly, disposable sensors may in some instances be more desirable than their reusable counterparts. 35

SUMMARY OF THE INVENTION

Accordingly, one object of the present invention is to 40
provide a disposable pulse oximetry sensor that has a reduced part count and it therefore easily produced.

Another objective of the present invention is to provide a pulse oximetry sensor that lends itself to production through an automated process. 45

A further objective of the present invention is to provide a disposable sensor that is economical to manufacture and use while providing required sensor performance.

The inventors of the present invention have recognized the increased need for the use of disposable medical sensors and in particular disposable pulse oximetry sensors. This increased need arises due to, inter alia, concerns in properly cleaning medical instruments between uses of communicable diseases, such as AIDS and Hepatitis B. In this regard, patients as well as hospitals may prefer using new medical 55
instruments, that is, medical instruments that have not been used previously. Additionally, the inventors have recognized that although reusable pulse oximetry sensors tend to initially be more expensive, their ability to be reused may lower their per-use cost below that of disposable pulse oximetry sensors currently existing, leaving hospitals and patients torn between their preferences and the financial realities of the health care system. Accordingly, the inventors have devised a reduced part count pulse oximetry sensor that is easily produced resulting in a disposable pulse 65
oximetry sensor that is cost effective on a per-use basis in comparison with reusable pulse oximetry sensors.

One or more of the above objectives and additional advantages are indeed realized by the present invention where, in one aspect, a pulse oximetry sensor having an integrally formed connector is provided. The sensor includes a substantially clear flexible substrate that may be con- 5
formed about a portion of a patient's tissue, such as a finger. This flexible clear substrate may be formed from any material that provides the desired flexibility and is substantially transparent, allowing for emitting and detecting light signals through this clear substrate. A particularly apt sub- 10
strate may be made from a polymer thick film (PTF) such as polyester. Mounted on a top surface of the clear flexible substrate is at least one active pulse oximetry component. That is, at least one light emitter, such as a light emitting diode, and/or a light detector, such as a photodiode. 15
Particularly, these active components are mounted on the top surface of the clear substrate such that they emit/detect light through the clear substrate and its bottom surface. In this regard, the clear substrate acts as a lens covering the active surfaces of the light emitter and/or light detector and reducing the overall part count required for the pulse oximetry sensor. Further, as noted, the sensor has an integrally formed connector that allows the flexible substrate to be intercon- 20
nected to, for example, an electrical pin connector connected to a pulse oximetry monitor. 25

Various refinements exist of the features noted in relation to the subject first aspect of the present invention. Further features may also be incorporated into the subject first aspect of the present invention as well. These refinements and additional features may exist individually or in any combination. For example, the bottom surface of the clear flexible substrate (i.e., the patient side of the sensor) may contain an adhesive and/or a release liner covering the adhesive for selectively securing the sensor to a patient's tissue. 30
Additionally, a compressible material layer may be disposed on the patient side surface of the flexible sensor for increased patient comfort. Preferably, any compressible material layer utilized will contain apertures aligned with each light emitter and/or light detector mounted on the top side of the clear flexible substrate, allowing light to be emitted and/or 35
detected through these apertures free from interference. Further, the flexible sensor may contain a light blocking layer applied to the top surface of the clear flexible substrate to minimize the effect of ambient light sources upon the sensor. This light blocking layer may include a separate 40
substrate interconnected to the clear flexible substrate or some sort of opaque coating applied to the top surface of the clear flexible substrate. 45

Regardless of which additional features the sensor utilizes, in a one embodiment, all materials applied to the bottom surface (i.e., patient side) of the clear flexible substrate contain a substantially clear portion aligned with the active pulse oximetry components. As will be appreciated, this provides for increased light transfer between a light emitter and/or detector upon application to an appendage as well as allowing for the utilization of light (e.g., ultra violet (UV) light or high intensity visible light) to cure various light-curable adhesives that may be used to mount one or more of the components to the clear flexible substrate during 50
manufacture. For example, the light emitter and/or detector may be encapsulated on top of the clear substrate using a light-curable clear adhesive to stabilize the emitter/detector as well as provide increased focusing of light into or from the clear substrate. Light may be applied through these layers and the bottom surface of the clear substrate to cure the adhesive(s). In a further embodiment, all the materials applied to the bottom surface of the clear substrate will be 55

3

at least partially transparent materials to allow light curable adhesives to be utilized in laminating the various materials together. In addition, or alternatively, thermal and/or mechanical pressure may be utilized to initiate or complete the cure of adhesives as well as thermally bond (i.e., laminate) one or more of the various material layers together.

In a second aspect of the present invention, a pulse oximetry sensor is provided comprising a substantially clear flexible substrate that may be conformed about a patient's tissue having, mounted on its top surface, at least one active pulse oximetry component. Again these active components (i.e., light emitter and/or light detector) are mounted on the clear substrate's top surface such that they emit/detect light through the clear substrate and its bottom surface. Further, the sensor includes at least one electrically conductive trace formed on the clear flexible substrate. The electrically conductive trace(s) is formed on the same surface (i.e., top surface) on which the emitters/detectors are mounted and provides an electrical connection between the integrally formed connector and the active components. This trace may be formed of any appropriate conductive material so long as it allows the substrate to freely flex. Examples of appropriate materials include thin metallic foils (e.g., 0.001 in) that may be stamped onto and/or melted into the clear substrate and conductive inks that may be printed onto the clear substrate.

Light emitters and detectors typically include a semiconductor die that contains first and second electrical contact pads that must be electrically interconnected with a power source to function. In this regard the light emitter and/or detector will be electrically interconnected to at least one electronically conductive trace. That is the emitter/detector may be mounted such that it electrically contacts the conductive trace using, for example, a conductive epoxy to attach an electrical contact pad on the emitter/detector to one or more electrically conductive traces.

Various refinements exist of the features in relation to the subject second aspect of the present invention. For example, the clear flexible substrate may have a plurality of electrical conductive traces formed on the surface containing the emitter and/or detector. In this regard, the active components (i.e., emitter and detector) may each be electrically interconnected to first and second electrical traces. That is, each active component may be electrically interconnected to "out" and "return" legs of what forms an electrical circuit when the sensor is connected to a pulse oximetry monitor. Further, the subject second aspect of the present invention may utilize any additional components interconnected to the flexible substrate such as those discussed above in reference to the first aspect of the present invention. Again, any additional components interconnected to the bottom surface of the subject second aspect of the present invention will preferably be at least partially transparent to realize the above described benefits.

In one embodiment of the second aspect of the present invention, the conductive traces are formed on the clear flexible substrate using a conductive ink, such as a silver epoxy, that is deposited onto the clear substrate. In this regard, the conductive traces may be deposited on the clear flexible substrate using a printing process such as, but not limited to, inkjet printing, screen printing, or pad printing. As will be appreciated, the use of ink printing allows for formation of conductive traces on the clear flexible substrate in a simplified manner in comparison to the utilization of, for example, chemical etching of a conductive surface such as copper, the use of a stamped lead frame, and/or the use of discrete wire conductors.

4

In a related aspect of the present invention, a pulse oximetry sensor is provided having a clear flexible substrate with at least one electrically conductive trace formed thereon and at least one light emitter electrically interconnected to one or more of those traces. The sensor further includes a thermal element adapted to transfer thermal energy away from the light emitter. As will be appreciated, when the light emitter is active (i.e., emitting light) the light emitter and the clear substrate to which it is mounted may become uncomfortably warm. This is especially evident where conductive ink traces are utilized on the clear flexible substrate, as conductive ink traces may not have enough thermal mass to effectively transfer heat away from the light emitter. Accordingly, undue heat build up around the light emitter may result in patient discomfort and/or tissue damage. Though in the present invention the thermal element is utilized to counteract the reduced thermal mass resulting from use of printed conductive traces, it will be appreciated that a thermal element may also be utilized with any pulse oximetry sensor to reduce potentially damaging heat concentrations. The thermal element may be formed of any material having high thermal conductivity such as, but not limited to, a copper sheet or washer that is thermally connected to the light emitter. In any case, the thermal element acts as a heat sink operable to draw heat away from the light emitter and dissipate that heat over an increased area to prevent excessive heat build up in a single area adjacent to a patient's tissue.

A related aspect of the present invention provides a sensor utilizing a clear flexible substrate on which a light emitter and/or detector is mounted for emitting/detecting light through the clear flexible substrate. This sensor further incorporates an insulative layer in a face-to-face relationship with at least a portion of a patient side surface (i.e., the bottom surface of the clear substrate) for creating a temperature differential between a patient's tissue and the bottom surface of the clear flexible substrate. As noted above, sensor active components and, in particular, the light emitting components may become uncomfortably warm during normal usage. In this regard, the insulative layer may be disposed on the bottom surface of the clear flexible substrate to provide a thermal buffer or "stand-off" between a patient's tissue and the bottom surface of the clear substrate.

In one embodiment, this insulative layer will contain apertures aligned with each of the active components mounted on the top surface of the clear flexible substrate. This arrangement allows the active components to emit/detect light free from interference. In a further embodiment utilizing the insulative layer, a substantially clear interconnecting layer will be interconnected to patient side surface of the insulative layer allowing the apertures within the insulative layer to be sandwiched between the clear interconnecting layer and the patient surface of the clear substrate. As will be appreciated, this produces an air pocket of "dead" air space between the patient's tissue and the bottom surface of the clear substrate, further reducing the possibility of undue heat build up against a patient's tissue. This pocket is preferably sealed to prevent the pocket deflation when the sensor is applied to the patient's tissue. Adhesives and/or thermal bonding of the various layers may be utilized to producing a sealed pocket.

In a further related aspect of the present invention, the flexible pulse oximetry sensor utilizes a first substrate having a top surface with one or more electrically conductive traces formed thereon and a second flexible substrate having a bottom surface with one or more electrical conductive

5

traces formed thereon. In this embodiment, one or more active sensor components (i.e. light emitters/detectors) are physically and electronically mounted to one of the substrates as well as being electrically interconnected to a conductive trace on the second flexible substrate. In this regard, the first and second flexible substrates may be disposed in a face-to-face relationship where the top and bottom surfaces containing the electrically conductive traces are disposed towards one another. As will be appreciated, this provides a sensor where the electrical traces, such as printed conductive ink traces, as well as the active sensor components are sandwiched between the first and second substrates and are thereby protected from the environment.

One or more of the above noted objectives and advantages may also be realized by an inventive method for forming a pulse oximetry sensor. The inventive method includes the steps of mounting onto the top surface of a substantially clear substrate, a light emitter for emitting light through the bottom surface of the substrate and/or a light detector for detecting light through the bottom surface of the substrate. The step of mounting may further include the step of electrically connecting the emitter/detector to one or more electrical traces associated with the clear substrate using, for example, a conductive epoxy. The mounting step may also include encapsulating the emitter/detector with a clear adhesive for increasing the light focusing capabilities of that component. The method further includes the step of applying light through the bottom surface of the clear substrate to at least partially cure one or more light-curable adhesives used for mounting emitters/detectors to the clear substrate.

A method is also provided for producing a flexible sensor having an integrally formed cord as well as an integrally formed connector. The process includes the steps of depositing at least one electrically conductive trace between first and second points on the surface of a flexible substrate sheet, which may be a clear flexible substrate. In order to produce an integrally formed cord having a length greater than that of the longest edge of the flexible substrate sheet, these traces are formed in a concentric pattern, continuously winding about a first point and gradually approaching a second point. For example, a first point may be located near the middle of a substantially square substrate sheet while the second point is located at one of the corners of the substrate sheet. The electrical traces connect the first and second points by winding about the first point in, for example, a circular or rectangular spiral pattern until they reach the second point. In one embodiment, the electrically conductive traces are formed between the first and second points on the substrate sheet using a conductive ink printing processes. Additionally, at least one light emitter and/or light detector are mounted on the flexible substrate and are electrically interconnected the conductive traces. Preferably, these emitters/detectors are mounted at the end of a trace to maximize the resulting length of the cord. Finally, the flexible substrate is cut between concentric windings of the electrical trace between the first and second points to form a flexible concentric strip having at least one electrically conductive trace between its first and second ends. This flexible concentric strip is then straightened to provide a flexible sensor having an integrally formed cord.

BRIEF DESCRIPTION OF THE DRAWINGS

FIG. 1 shows an exploded perspective view of a prior art pulse oximetry sensor;

FIG. 2 shows a plan view of the metallic lead frame utilized with the pulse oximetry sensor of FIG. 1;

6

FIG. 3 shows a cross sectional view of a photodetector attached to the lead frame of FIG. 2 taken along section lines A-A';

FIG. 4 shows a plan view of the metallic lead frame of FIG. 2 utilizing an adhesive encapsulant to stabilize the active components;

FIG. 5 shows a top plan view of a disposable sensor in accordance with the present invention;

FIG. 6 shows a cross sectional view of the layers making up the disposable sensor of FIG. 5 taken along section lines A-A';

FIG. 7 shows a plan view of one embodiment of the electrically conductive traces formed on the top surface of the sensor of FIG. 5;

FIG. 8a shows a cross sectional view of one of the active components interconnected to the top surface of the disposable sensor of FIG. 5 taken along section lines B-B';

FIG. 8b shows a cross sectional view of an alternate connection one of the active components interconnected to the top surface of the disposable sensor of FIG. 5 taken along section lines B-B';

FIG. 9 shows a perspective view of one embodiment the integral connector of the disposable sensor of FIG. 5;

FIG. 10 shows a stiffener utilized with the integral connector of FIG. 9;

FIG. 11 shows a cross sectional view of an alternate combination of layers making up the disposable sensor of FIG. 5 taken along section lines A-A', wherein said sensor includes a thermal element;

FIG. 12 shows a plan view of a flexible sensor in accordance with the present invention that utilizes two flexible substrates having electrically conductive traces formed thereon;

FIG. 13 shows a plan view of a flexible sensor of the present invention having an integrally formed cord;

FIGS. 14a-d shows a process for straightening the cord of the flexible sensor of FIG. 13;

FIG. 15 shows a fresnel lens that may be incorporated into the clear substrate of any of the above embodiments of the sensor.

DETAILED DESCRIPTION

FIGS. 1-4 illustrate one embodiment of a prior art flexible oximetry sensor. FIG. 1 shows an exploded view of the sensor assembly 350. Included within the assembly 350 are upper and lower flexible members 304 and 300, respectively. These members 300, 304 are thermally bonded to one another sandwiching a leadframe 308 between their inside surfaces. This leadframe 308 contains active components (i.e., LEDs and a photodetector) for use in oximetry measurements, as will be more fully discussed in reference to FIG. 2. As will be appreciated, at least one of the flexible members 300 and 304 contains apertures 360, 362 aligned with the active components to allow a line of sight to exist between these active components and to a patient's tissue upon sensor application. The sensor assembly 350 also contains a pin connector 346 interconnected to a cable 364 that is soldered to the leadframe 308. The pin connector 346 is used to connect sensor assembly 350 to an oximetry monitor (not shown).

FIG. 2 shows a close-up view of the leadframe 308. The leadframe 308 is preferably composed of the conducting material, such as copper, and is preformed (e.g., stamp pressed or chemically etched) into a shape and size for use

with the upper and lower flexible members **304** and **300**. The lead frame contains a plurality of conductive traces **310–320** for conducting electrical signals through the sensor's active components **330–334**. In particular the active components include LEDs **330**, **332** and photodetector **334**. These components **330–334** are each electrically interconnected to two of the traces to form an electrical circuit there through. FIG. 3 shows a side view of the interconnection of the photodetector **334** to the leadframe **308** along section lines A–A'. It will be appreciated that the LED's **330** and **332** are interconnected in a substantially identical manner albeit to different electrical traces. As shown, the photodetector **334** contains first and second contact pads **336** and **338** located on its top and bottom surfaces, respectively. The bottom contact pad **338** as well as the photodetector **334** is interconnected to trace **320** by a conductive adhesive bond **322**. In this regard, a drop of the conductive adhesive may be placed on the surface of the trace **320** after which the photodetector **334** is pressed into the conductive adhesive thereby creating an electrical interconnection between the bottom contact pad **338** and the trace **320**. The conductive adhesive is then cured using, for example, heat. All the active components **330–334** are mounted directly to a trace **312**, **318**, and **320** which has a width greater than the respective component **330–330** mounted thereon. Accordingly, the emitting and detecting surfaces of the components **330–334** are necessarily mounted such that they emit/detect in a direction other than the direction of the trace on which they are mounted. As shown in FIG. 3, the photodetector's active surface is located on its top surface. Likewise, the active surfaces of the LEDs **330** and **332** are mounted to emit from their top surfaces, however, it will be appreciated that the LEDs **330**, **332** also emit a substantial portion of light through their side surfaces. To complete the electrical circuit through the photodetector **334** the top contact pad **336** is interconnected to a second electrical trace **310**. This connection is made using a ductile connector wire **324** (e.g., gold) that is wire bonded to the top contact pad **336**, routed to the second electrical trace **310**, and wire bonded to the second trace **310**.

The ductile wire connector **324** is made of a small gauge wire. Additionally, the individual traces **310–320** must remain electrically isolated from one another to prevent electrical shorting there between. Therefore, in order to stabilize the wire connector **324** and isolate the traces **310–320** a clear nonconductive adhesive is utilized to encapsulate the active components **330–334** and portions of the traces **310–320**. That is, a first adhesive drop **332** encapsulates the LEDs **330**, **332** and a portion of all the traces **310–320** while a second adhesive drop **332** encapsulates the photodetector **334** and traces **320** and **310**. These adhesive drops **332** are cured using UV light, light and/or heat to form clear solids which provide structural stability for the sensor **350** as well as lenses to help direct light emitted or received by the active components **330–334**.

As will be appreciated, the prior art sensor **350** requires the forming of a conductive lead frame **308**, application of active components **330–334** using a conductive adhesive, curing of the conductive adhesive, wire bonding, application and curing of clear adhesive bubbles to stabilize the sensor assembly **350**, soldering the lead frame **308** to a pin connector **346** and finally sandwiching the lead frame assembly between the upper and lower flexible members **300** and **304**.

FIG. 5 shows a top view of one embodiment of a low cost oximeter sensor assembly **30** having an integral connector **34**, in accordance with the present invention. Generally, the sensor **30** is formed having a flexible sheet-like laminate **50**

structure which includes first and second opposing wings **52**, **54**, as well as a finger-tip projection **56** oriented between and projecting perpendicular to the wings **52**, **54**. The wings **52**, **54**, along with the finger-tip projection **56**, are used for flexibly wrapping the sensor **30** about a finger **60** (shown in phantom) such that one or more LED's **40**, **42** are disposed on a first surface of the finger and a photodetector **38** is disposed on an opposing surface of the finger. It will be noted that the sensor **30** may be differently shaped for use with other patient extremities. The top "non-patient" side of the laminate structure **50** further contains a plurality of electrically conductive traces **70**, **72**, **74**, **76**. These traces **70**, **72**, **74**, **76** electrically interconnect the active sensor components **38–44** to an electric power source and monitor (not shown). In particular, the sensor **30** contains a photodetector **38** interconnected to trace **70** and two light emitting diodes (LEDs) **40**, **42** interconnected to traces **72** and **74**, respectively. Additionally, the sensor **30** contains an identification means **44** interconnected to trace **76**. This identification means **44** may be any component or combination of components. For example, the identification means **44** may comprise one or more passive and/or active electrical components (e.g., resistors, diodes, zener diodes, etc.) or memory device (e.g., a programmable integrated chip, etc.) used to provide some sort of sensor **30** identification information. IN turn, upon reading the identification means **44**, an oximetry monitor (not shown) may apply appropriate calibration values related to, for example, the center wavelengths of the LEDs **40**, **42** for a particular sensor **30**. The active components **38–44** may be encapsulated with a clear drop **110** of adhesive (as shown in phantom lines surrounding the active components **38–44**) to provide structural stability and improved optical characteristics, as will be discussed herein. FIG. 6 shows an exploded cross sectional view along projection line A–A' of the sensor **30** shown in FIG. 5. Identical components in FIGS. 5 and 6 are identified with the same reference numbers. FIG. 6 shows the different layers utilized to form the flexible substance of the present embodiment of the "laminate" sensor **30** of the present invention. Included in the laminate's layers are a clear substrate **80**, an interconnecting layer **82** with a patient side adhesive surface **83** and a clear release liner **84** in face-to-face contact with the adhesive surface **83**. A foam layer **86** is also disposed between a portion of the clear substrate layer **80** and the interconnecting layer **82**. This foam layer **86** provides for increased patient comfort by providing cushioning and a thermal barrier between the patient's tissue and the LED's **40**, **42** (LED **40** is disposed directly behind LED **42** and, therefore, not shown directly in this view), as will be more fully discussed herein. Each of the laminate's layers **80–86** are flexible such that the sensor **30** is able to conform to a patient's tissue and hold the LED's **40**, **42** and the photodetector **38** relative to the tissue. Further, the interconnecting layer **82** and clear substrate **80** are made of the same/similar material, such as polyester, polyethylene, polypropylene, or polyamide so that during manufacture of the sensor **30**, the clear substrate **80** and interconnecting layer **82** may be thermally bonded to one another using heat and pressure. Thermal bonding eliminates the need of a separate adhesive for attaching the clear substrate **80** and interconnecting layer **82** and also provides a method for securely holding the foam layer **86** in place (i.e., sandwiching the foam between the layers). Additionally, the heat form the thermal bonding step may be utilized to cure adhesives utilized to attach various components to the sensor **30**. The foam layer **86** may be made of material similar to the clear substrate **80** and interconnecting layer **82** such that the foam

layer **86** at least partially bonds to these layers **80**, **82** during manufacture. The release liner **84** is made of a dissimilar material to prevent it from bonding to the interconnecting layer **82**, thereby allowing it to remain removable prior to sensor application.

The release liner **84**, the interconnecting layer **82**, the foam layer **86** and the clear substrate layer **80** are formed of materials that are substantially transparent to ultraviolet (UV) light. This allows UV light to pass through these layers **80–86** such that any adhesives used to attach the LEDs **40**, **42** and photodetector **38** to the electrical traces **70–76** and/or to the clear substrate **80** (i.e., adhesive drop **110**) may be cured with light (i.e., UV or visible depending on the adhesives) applied through the bottom of the flexible substrate **50** at or near the end of the manufacturing process. The foam layer **86** contains a plurality of apertures **88–92** (Aperture **90** is aligned with LED **4** in FIG. **6** and is therefore not shown) aligned with the active components **38–44**, thus allowing UV/light to access those components **38–44** for curing purposes. Further, the foam layer **86** is partially transparent, allowing a predetermined portion of light to pass through for curing and/or monitoring purposes. In the present embodiment, where there is no light blocking layer on the top side of the laminate **50**, the use of substantially UV transparent materials allows for curing any adhesives with UV/light sources from either side of the sensor **30**. This is especially important in other embodiments where a light blocking layer is applied to the flexible substrate **50** top surface, as will be more fully discussed herein. Alternately, thermal energy used to bond the laminate layers **50** may also be utilized to cure the adhesives used to bond the electrical components **38–44** to the sensor **50**.

As noted, the clear substrate **80** is formed of a polymer thick film such as polyester, polyethylene, polypropylene, or polyamide. The clear substrate **80** provides a mounting surface for the LED's **40**, **42** and photodetector **38**. In this regard, these components are mounted in contact with the clear substrate **80** such that the clear substrate **80** acts at least partially as a lens, eliminating the need of separately formed lens structures for the sensor **30**. However, it will be appreciated that the drops **110** of clear adhesive may also provide some focusing function for the LEDs **40**, **42**. That is, the adhesive drops **110** may reflect light emitted through, for example, side surfaces of the LEDs **40**, **42** through the clear substrate **80**.

The foam layer **86**, as noted, contains three apertures **88–92**, one for each of the LEDs **40**, **42** and one for the photodetector **38**. Accordingly, these apertures **88–92** are aligned with the LEDs **40**, **42** and photodetector **38** upon assembly such that a clear line of sight exists between the LEDs **40**, **42** and photodiode **38** when the sensor **30** is applied to the patient's finger **60**. The LED apertures **88**, **90** provide an additional benefit in that they create a trapped air pocket between the bottom surface of the clear substrate layer **80** and the interconnecting layer **82**. During operation of the sensor **30**, the LEDs **42**, **40** produce heat which may cause the clear substrate **80** to become uncomfortably warm. Sensors utilizing copper lead frames, or copper traces formed using conventional printed board technology generally provide enough of a "heat sink" to conduct excess heat away from the LED area, preventing undue heat build up. However, in the present invention, where the traces **70–76** are formed using conductive ink, heat dissipation can become problematic. In this regard, the air pocket formed by the foam layer apertures **88**, the clear substrate **80** and the interconnecting layer **82**, creates a thermally insulative buffer between the patient's finger **60** and the clear substrate

80. This buffer eliminates or substantially reduces the potential for tissue damage. As will be appreciated, this air pocket may be airtight. That, is the pocket may be sealed when the clear substrate **80** and interconnecting layer **82** are thermally bonded together.

FIG. **7** shows a close up view of electrical traces of **70–76** and the electrical components **38**, **40**, **42** and **44** attached thereto. As shown, each trace **70–76** includes two substantially parallel electrically conductive paths a and b, which are electrically insulated from one another. The first half of these electrical paths (**70a–76a**) form "out" legs of electrical circuits and the second parallel paths (**72b–76b**) form the "return" legs of the electrical circuits once the sensor's active components **38–44** are interconnected to their respective traces **70–76**. The traces **70–76** of the present embodiment are formed on the top surface of the clear substrate **80** using a conductive ink (e.g., epoxy with silver). This conductive ink may be deposited on the clear substrate **80** using any of a number of known ink deposition techniques such as silk screening, pad printing or inkjet printing. During the ink deposition process, the remainder of the surface of the clear substrate **80** not covered by the conductive traces **70–76** (and not to be covered by the LED **40**, **42** or Photodetector **38**) may also be covered by an opaque nonconductive ink. That is, the non-patient side of the clear substrate **80** may be "painted" to provide a light blocking shield for the sensor **30**. Finally, any sensor identification marks may also be printed on the sensor during the ink deposition process(es). Alternatively, the traces **70–76** may include metallic conductors formed on the clear substrate using conventional printed board technology or hot foil stamping. The use of copper/metallic traces may allow for conducting heat away from the LEDs **40** during sensor operation. In addition, the metallic traces may provide for additional light reflection, providing increased signal transfer through the patient's finger **60**.

FIGS. **8a** and **8b** illustrate alternate embodiments for attaching the LEDs **40**, **44**, photodetector **38** and identification means **44** to the traces **70–76** on the clear substrate **80**. In particular, FIGS. **8a** and **8b** show a cross sectional view along projection line B–B' of the sensor **30** shown in FIG. **1**. Though FIGS. **8a** and **8b** describe the attachment of LED **42** to electrical trace **72**, it is to be understood that any or all of the active components **33–44** of the sensor **30** contain similar structures and may be interconnected to their respective traces **70–76** in a substantially identical manner. As shown in both FIGS. **8a** and **8b**, LED **42** contains a first electrical contact pad **102** and a second electrical contact pad **104**. These electrical contact pads **102**, **104** are interconnected with the out leg **72a** and return leg **72b** of electrical trace **72**. In accordance with the present invention, the LED **42** is mounted such that it emits light through the clear substrate **80** which, in turn, acts as a lens for the LED **42**.

In FIG. **8a**, LED **42** is shown as a "flip chip" having both electrical contact pads **102**, **104** located on the same surface of the LED **42**. Further, the first and second electrical contact pads **102**, **104** are located on the same surface as the LED's light emitting surface. In this regard, the electrical contact pads **102**, **104** are easily interconnected to the out and return legs **72a** and **72b** on the clear substrate **80** using an electrically conductive adhesive to form conductive bonds **112**, **113** between the trace legs **72a**, **72b** and the contact pads **102**, **104**.

FIG. **8b** illustrates an alternative embodiment for use when LED **42** contains first and second electrical contact pads **102**, **104** oriented on opposing faces of the LED **42**. In this arrangement, a bead of the conductive adhesive is used

to interconnect the top electrical contact pad **104** to the return leg **72b** of the trace **72**. That is, the electrically conductive adhesive is used to create an electrical conduit **114**. The bottom contact pad **102** is again directly interconnected to the out leg **72a** of the electrical trace **72** using a conductive bond **112**. As will be appreciated, in both embodiments using the electrically conductive adhesive eliminates the need for wire bonding and/or soldering of the LED **42** to the trace **72**. The conductive bonds **112**, **113** and/or **114** may then cured (i.e. thermally or with light).

In addition to being attached to the clear substrate via the electrically conductive bonds **112**, **113** and/or **114**, a clear adhesive is used to attach LED **42** to the clear substrate **82**. The clear adhesive creates an adhesive drop **110** that encapsulates the entire LED **42** and the electrical connections to the electrical traces. Upon curing, the adhesive drop **110** provides stability for the electrical connections and also increases light focusing through the clear substrate **80** by refracting light emanating through the sides of the LED **42** through the clear substrate **80**. As will be appreciated, the LED **42** must be attached to the electrical out and return legs (**72a** and **72b**) of the electrical trace **72** with the conductive adhesive **112** prior to encapsulating the LED **42**. The clear adhesive may then be applied around and flowed into any spaces beneath the LED **42** to secure the LED **42** to the clear substrate **80**. Preferably, the clear adhesive covers the entire LED **42**, thereby encapsulating the LED **42** within the drop **110**. The clear adhesive may then be cured thermally or by utilizing light that may be applied from above or beneath the sensor laminate **50** as described above. If the conductive adhesive is viscous enough to maintain the bond between the contact pads **102** and **104** and traces **72a** and **72b** during encapsulation, curing of the conductive and clear adhesives may be done simultaneously.

FIGS. **9** and **10** illustrate various components of the integral connector **34** formed on one end of the sensor **30**. The integral connector **34** is designed to interface to the connector plug **38** which is interconnected with an oximetry monitor (not shown). Generally, the connector plug **38** contains an opening **120** having a plurality of contact pins **122** which are operable to interconnect with the traces **70-74** located on the clear substrate **80**. The contact pins **122** act as springs such that upon insertion of the integral connector **34** within the connector plug opening **120** the contact pins **120** maintain contact pressure with the traces **70-76**. As will be appreciated, a contact pin exists for each out leg and each return leg of each of the traces **70-76**. As shown in FIG. **10**, the integral connector **34** is formed by folding the laminate **50** along a fold line **64** such that the traces **70-76** on the non-patient surface of the clear substrate are exposed on both sides of the integral connector **34**. In order to provide the structural integrity necessary for the connector **34** to interface with the connector plug **38**, a stiffener **36** is inserted in the fold of the laminate structure **50**. This stiffener **36** may be made of any suitable material that has a relative stiffness greater than that of the flexible substrate **50**. Preferably, the stiffener **66** will be made of a similar material to the flexible substrate **50** rest of the sensor **30** such that it may be thermally bonded in place. The stiffener **36** provides structural stiffness, allowing a technician to interconnect the integral connector **34** with the connector plug **38**. Additionally, the stiffener **36** provides volume within the fold such that the connector pins **122** within the connector plug **38** may effectively contact with the traces **70-76** upon insertion.

FIGS. **11** and **12** illustrate another embodiment of the sensor in accordance with the present invention. This second

embodiment is similar in structure to the first embodiment shown in FIGS. **5** and **6**, however, this embodiment further utilizes a cover layer **94** covering the top surface of the clear substrate. FIG. **11** shows a plan view of the top surface of the clear substrate **80** and the bottom surface of the cover layer **94**. FIG. **12** shows an exploded side view along projection line C-C' of FIG. **11** and includes the cover layer **94**. The cover layer **94** covers substantially the entire top surface of the clear substrate **80**, excluding the portion of the clear substrate that makes up the integral connector **34**. The cover film layer **94** is generally an opaque flexile layer made of a material similar to the clear substrate **80** and is utilized for its light blocking characteristics. As with the embodiment of FIGS. **5** and **6**, the cover layer **94** may be thermally bonded to the clear substrate **80** during manufacture. In addition, the embodiment shown in FIGS. **11** and **12** includes a heat sink **92** that is disposed between the clear substrate **80** and the cover layer **94** in the region of the LEDs **40**, **42**. Upon sensor assembly, the heat sink **92** is "sandwiched" between the cover layer **94** and the clear substrate **80**. The heat sink may be any thermally conductive material, such as a copper disk, that provides adequate heat transfer away from the LEDs **40**, **42** to prevent the LEDs **40**, **42** from overheating during sensor operation. This heat sink **92** is especially desirable when conductive inks are utilized to form the traces **70-76**, as conductive inks generally do not provide enough thermal mass to provide adequate heat transfer away from the LEDs **40**, **42**, which can lead to patient discomfort and/or tissue damage (i.e. burns).

In the embodiment of FIGS. **11** and **12** the cover layer **94** contains one or more of the traces **70-76** utilized for connecting the active components **38**, **42**, **40**, **44** of the sensor **30**. FIG. **12** shows a plan view of the bottom of the cover layer **94** and the top of the clear substrate **80** prior to lamination (not to scale). For clarity herein only LED **40** and the electrical traces connected thereto are described. In particular, the LED **40** contains a contact pad **104** interconnected to the clear substrate layer **80** (See FIG. **8b**) and a contact pad **102** on its top surface. Accordingly, the cover layer **94** contains one of the out or return legs (i.e., a or b) of electrical trace **72** to facilitate electrical connection. As noted for simplicity, only one electrical component (LED **40**) and its corresponding trace **72** are illustrated, however it is to be understood all the traces **70-76** for all active components are formed in a like manner. In this embodiment, the LED's bottom contact pad **104** (not shown) is electrically interconnected with trace **72b** located on the clear substrate **80** using, for example, a conductive adhesive. The LED's top contact pad **102** is interconnected to trace **72a** located on the bottom surface of the cover layer **94**. As will be appreciated, upon lamination of the sensor **30** the cover layer trace **72a** is electrically isolated from the corresponding clear substrate layer traces **72b**. That is, each trace leg a and b is offset or jogged such that they take an individual path to and from the LED **40**. Finally, to utilize the integral connector **34** in accordance with the present invention, both legs a and b of the conductive traces **72** must be disposed on the outside of the clear substrate **80** when folded. Accordingly, the cover layer **94** does not extend to the sensor's integral connector **34** section (see FIG. **12**). To provide electrical connections to the cover layer trace **74a**, the cover layer trace **74a** further contains a contact pad **74c** that is able to electrically mate with a contact pad **74d** on the clear substrate **80** when the cover layer **94** and clear substrate **80** are contacted. The clear substrate contact pad **72d** further contains an electrical trace **74e** that leads to the integral connector **34**. Upon sensor lamination, the contact

pads **74c**, **74d** are thermally and electrically bonded and provide electrical connection to the integral connector **34**.

The cover layer **94** provides for added sensor structural integrity and additional protection for the electrical components **38–44**. As will be appreciated, when the cover layer **94** is utilized, all the electrical components **38–44** are sandwiched between the cover layer **94** and clear substrate **80**. As these layers are thermally bonded in the lamination of the sensor **30**, the resulting laminate **50** has its active components **38–44** securely embedded within, providing a sensor assembly having increased resiliency.

FIG. **13** shows another embodiment of the present invention. In this embodiment, the clear structure **80** and the conductive traces **70–76** are formed in a square concentric spiral pattern on a single sheet of laminate. The concentric sensor **130** contains LEDs **40**, **42** a photodetector **38** and an identification means **44** all located at the end of the concentric traces **70–76** near the middle of the sheet of laminate. In accordance with the present invention, the LED's **40**, **42** and the photodetector **38** may be mounted such that they emit/detect through a clear substrate. The concentric sensor **130** may utilize any combination of layers as described in relation to the embodiments above. What is important is that the concentric sensor provides a sensor having an integrally formed cable that is formed on a single "sheet" of laminate while producing an integral cable that is longer than the outside dimensions of the sheet. In this regard, after the traces are applied to the laminate sheet, the sheet is cut between the concentric traces **70–76** to produce an integral cable **35** that has a square spiral shape (see FIG. **14a**). In order to straighten the cable, the square corners **140** of the sensor **130** are each first folded back at a 45 degree angle (See FIG. **14b**) and then refolded straight forward (see FIG. **14c**), allowing the integral cable **35** to take the form of a long strip (FIG. **14d**). As will be appreciated, the integral cable allows the connection of the sensor **130** to a monitor to be made at an increased distance away from the patient's tissue.

As will be appreciated, any of the previous embodiments may further utilize additional layers/materials to provide further enhanced sensor characteristics. For example, as shown in FIG. **15**, a separate lens structure may be utilized if the refractive properties of the clear substrate **80** are not sufficient to properly direct/focus the light emitted/received by the emitters/detector **40**, **42** and/or **38**. In this regard, a lens, such as a fresnel lens **200**, may be integrally formed into the clear substrate **80**. Alternatively the clear substrate **80** may be over-molded onto an existing lens **200**. In either case, an LED **40** may be mounted upon the back surface of the lens **200** to allow the light emitting from the LED **40** to be concentrated into a more unidirectional light beam.

The foregoing description of the present invention has been presented for purposes of illustration and description. Furthermore, the description is not intended to limit the invention to the form disclosed herein. Consequently, variations and modifications commensurate with the above teachings, and skill and knowledge of the relevant art, are within the scope of the present invention. The embodiments described hereinabove are further intended to explain best modes known of practicing the invention and to enable others skilled in the art to utilize the invention in such, or other embodiments and with various modifications required by the particular application(s) or use(s) of the present invention. It is intended that the appended claims be construed to include alternative embodiments to the extent permitted by the prior art.

What is claimed is:

1. A flexible pulse oximetry sensor, said sensor comprising:
 - a substantially clear flexible substrate having first and second surfaces;
 - at least one of:
 - a light emitter mounted on said first surface of said clear substrate for emitting light through said substrate and said second surface; and
 - a light detector mounted on said first surface of said clear substrate for detecting light through said second surface and said substrate and providing a signal indicative of said detected light; and
 - a substantially clear adhesive for at least partially attaching by way of direct interconnection said at least one of said light emitter and said light detector to said clear substrate.
2. The pulse oximetry sensor of claim 1, further comprising:
 - a substantially clear adhesive on said second surface for securing said sensor to a patient's tissue.
3. The pulse oximetry sensor of claim 2, further comprising:
 - a substantially clear release liner for covering said adhesive, wherein said release liner may be selectively removed prior to application of said sensor to a patient's tissue.
4. The pulse oximetry sensor of claim 1, wherein said clear adhesive encapsulates said at least one of said light emitter and said light detector.
5. The pulse oximetry sensor of claim 1, wherein said clear adhesive is light curable.
6. The pulse oximetry sensor of claim 1, further comprising:
 - a substantially clear interconnecting layer interconnected to at least a portion of said second surface of said clear substrate;
 - an at least partially transparent compressible layer disposed between at least a portion of said interconnecting layer and said clear substrate; and
 - a substantially clear adhesive on at least a portion of said second surface for securing said sensor to a patient's tissue.
7. The pulse oximetry sensor of claim 6, wherein said compressible layer has a transparency index of at least 0.4.
8. The pulse oximetry sensor of claim 6, wherein said compressible layer contains at least a first aperture for each said light emitter and said light detector, wherein each said aperture is aligned with each said light emitter and light detector to allow light to pass through said aperture free from interference.
9. The pulse oximetry sensor of claim 8, wherein said interconnecting layer, said aperture and said clear substrate form an air pocket.
10. The pulse oximetry sensor of claim 9, wherein said air pocket is air tight.
11. The pulse oximetry sensor of claim 1, wherein said sensor contains at least one light emitter, further comprising:
 - a thermal element being adapted to transfer thermal energy away from said at least one light emitter.
12. The pulse oximetry sensor of claim 1, wherein said clear flexible substrate further comprises a lens integrally formed within said substrate to focus light relative to said at least one of light emitter and light detector.
13. The pulse oximetry sensor of claim 1, wherein said substantially clear flexible substrate at least partially forms a connector adapted to connect said pulse oximetry sensor to a monitor.

15

14. A flexible pulse oximetry sensor, said sensor comprising:

a substantially clear flexible substrate having a first surface with at least one electrically conductive trace formed thereon; and

at least one of:

a light emitter mounted on said first surface of said clear substrate and electrically interconnected to at least one said trace, said light emitter for emitting light through said substrate and a second surface of said substrate; and

a light detector mounted on said first surface of said clear substrate and electrically interconnected to at least one said trace, said light detector for detecting light through said second surface and said substrate and providing a signal indicative of said detected light.

15. The pulse oximetry sensor of claim 14, further comprising:

a substantially clear adhesive on said second surface for securing said sensor to a patient's tissue.

16. The pulse oximetry sensor of claim 15, wherein said at least one electrically conductive trace is formed from a conductive ink deposited onto said clear substrate.

17. The pulse oximetry sensor of claim 16, wherein said conductive ink is deposited on said first surface using a printing process.

18. The pulse oximetry sensor of claim 15, wherein said at least one electrically conductive trace is formed from a metallic foil stamped onto said clear substrate.

19. The pulse oximetry sensor of claim 14, wherein said substantially clear flexible substrate at least partially forms a connector adapted to connect said pulse oximetry sensor to a monitor.

20. A flexible pulse oximetry sensor, said sensor comprising:

a substantially clear flexible substrate having at least one electrically conductive trace formed on a first surface;

at least a first light emitter electrically interconnected to at least one said electrically conductive trace on said flexible substrate, said light emitter for emitting light through said substrate relative to a patient's tissue; and

a thermal element being adapted to transfer thermal energy away from said at least one light emitter when said light emitter is emitting light; and

an adhesive on said second surface of said flexible substrate for securing said sensor to a patient's tissue.

21. The pulse oximetry sensor of claim 20, wherein said at least one electrically conductive trace is formed from a conductive ink printed on said flexible substrate.

22. The pulse oximetry sensor of claim 20, wherein said thermal element comprises a thermally conductive material at least partially covering said first surface.

23. The pulse oximetry sensor of claim 22, wherein said thermally conductive material is electrically isolated from said at least one electrically conductive trace.

24. The pulse oximetry sensor of claim 20, wherein said substantially clear flexible substrate at least partially forms a connector adapted to connect said pulse oximetry sensor to a monitor.

25. A flexible pulse oximetry sensor, said sensor comprising:

a substantially clear flexible substrate having first and second surfaces; and

at least one of:

a light emitter mounted on said first surface of said clear substrate for emitting light through said substrate and said second surface; and

16

a light detector mounted on said first surface of said clear substrate for detecting light through said second surface and said substrate and providing a signal indicative of said detected light; and

an insulative layer in a face to face relationship with at least a portion of said second surface for creating a temperature differential between a patient's tissue and said second surface opposite said at least one emitter and detector.

26. The pulse oximetry sensor of claim 25, further comprising:

a substantially clear interconnecting layer interconnected to at least a portion of said insulative layer; and an adhesive on the bottom surface of said interconnecting layer for attaching said sensor to a patient's tissue.

27. The pulse oximetry sensor of claim 26, wherein said insulative layer contains at least a first aperture for each said light emitter and each said light detector, wherein said aperture is aligned with said light emitter and said light detector to allow-light to pass through said aperture free from interference.

28. The pulse oximetry sensor of claim 27, wherein said clear substrate second surface, said aperture and said interconnecting layer are adapted to create an air pocket between said substrate and a patient's tissue.

29. The pulse oximetry sensor of claim 28, wherein said air pocket is substantially sealed.

30. The pulse oximetry sensor of claim 25, wherein said substantially clear flexible substrate at least partially forms a connector adapted to connect said pulse oximetry sensor to a monitor.

31. A flexible pulse oximetry sensor, said sensor comprising:

a first flexible substrate having a first surface with at least a first electrically conductive trace thereon,

a second flexible substrate having a first surface having at least a first electrically conductive trace thereon, wherein said first substrate first surface and second substrate first surface are in a face to face relationship and wherein one of said substrates is substantially clear, at least one of:

a light emitter mounted on the first surface of one of said first and second substrates, wherein said light emitter is electrically interconnected to at least one trace on said first substrate and at least one trace on said second substrate and wherein said light emitter emits light through said substantially clear substrate; and

a light detector mounted on the first surface of one of said first and second substrates, wherein said light detector is electrically interconnected to at least one trace on said first substrate and at least one trace on said second substrate and wherein said light detector detects light through said substantially clear substrate; and

an adhesive on a second surface of one of said first and second substrates for securing said sensor to a patient's tissue.

32. The sensor of claim 31, wherein said first substrate traces and second substrate traces are electrically isolated.

33. The sensor of claim 31, wherein at least one of said light emitter and light detector is mounted to said clear substrate allowing light to be one of emitted through said clear substrate and detected through said clear substrate.

34. The sensor of claim 31, wherein the other of said first and second substrates is substantially opaque.

* * * * *