

69,082
32d

MAR 17 1965

ENGINEERING

February 2, 1965
DMIC Memorandum 199

MACHINING OF TITANIUM ALLOYS

DEFENSE METALS INFORMATION CENTER

BATTELLE MEMORIAL INSTITUTE

COLUMBUS 1, OHIO

Engineering Library
University of Arkansas

UNIVERSITY OF ARKANSAS
LIBRARY



Digitized by 3 9015 09515 5738

The Defense Metals Information Center was established at Battelle Memorial Institute at the request of the Office of the Director of Defense Research and Engineering to provide Government contractors and their suppliers technical assistance and information on titanium, beryllium, magnesium, aluminum, refractory metals, high-strength alloys for high-temperature service, corrosion- and oxidation-resistant coatings, and thermal-protection systems. Its functions, under the direction of the Office of the Director of Defense Research and Engineering, are as follows:

1. To collect, store, and disseminate technical information on the current status of research and development of the above materials.
2. To supplement established Service activities in providing technical advisory services to producers, melters, and fabricators of the above materials, and to designers and fabricators of military equipment containing these materials.
3. To assist the Government agencies and their contractors in developing technical data required for preparation of specifications for the above materials.
4. On assignment, to conduct surveys, or laboratory research investigations, mainly of a short-range nature, as required, to ascertain causes of troubles encountered by fabricators, or to fill minor gaps in established research programs.

Contract No. AF 33(615)-1121
Project No. 8975



Roger J. Runck
Director

TABLE OF CONTENTS

	<u>Page</u>
GENERAL CONSIDERATIONS.	1
Introduction	1
Machining Titanium	1
CONVENTIONAL MACHINING.	3
Milling Operations	3
Face Milling Operations.	6
Peripheral Milling Operations.	8
Turning and Boring Operations.	8
Drilling Operations.	11
Drilling Requirements.	11
Tapping Operations	14
Tapping Requirements	14
GRINDING TITANIUM	16
Precision Wheel Grinding	16
Abrasive Belt Grinding	18
General Grinding Recommendations	19
UNCONVENTIONAL MACHINING.	21
Chemical Milling Operations.	21

MACHINING OF TITANIUM ALLOYS

C. T. Olofson, A. F. Gerds, F. W. Boulger, and J. A. Gurklis*

GENERAL CONSIDERATIONS

Introduction

Ten years ago, titanium had the reputation of being very difficult to machine, compared to common constructional materials. However, Government and private research on titanium machining, experience, and the use of all information generated has progressively improved this situation.

During 1957, the Titanium Metallurgical Laboratory, now the Defense Metals Information Center, published TML Report 80 which summarized the state of the art of machining titanium and the alloys available at that time. The present memorandum combines the basic information from this and other TML and DMIC publications with more recent data obtained from Government reports and personal interviews. DMIC also acknowledges the assistance of the Federal Aviation Agency in updating this information in particular on Ti-8Al-1Mo-1V and Ti-6Al-6V-2Sn through their support at Battelle of a program to develop a handbook on titanium alloys.

There have been no major breakthroughs in machining titanium alloys, although more data on Ti-13V-11Cr-3Al and other new alloys could be forthcoming. It can be stated, however, that as various companies using titanium alloys gain experience, there is a steady improvement in rates of metal removal. This increase is caused partly by increased uniformity in the alloy, and partly by strict attention to the machining conditions required for titanium.

Today, tools and techniques are available for machining titanium efficiently. In fact, some machining operations give more consistent results on titanium than they do on some grades of steel. A bonus factor is the ease of attaining good surface finishes. Rms values as low as 20 to 30 microinches can be obtained on some titanium parts without much trouble.

Machining Titanium

Machining Behavior

The machinability of unalloyed titanium is similar to that of annealed austenitic stainless steels, while titanium alloys are more comparable to 1/4-hard and 1/2-hard stainless steels. Table 1 shows the approximate machinability relationships between the titanium alloys and the other alloys of interest to the aircraft industry.

Generally speaking, machining problems for titanium originate from three sources: excessive cutting temperatures, chemical reactivity with tools, and a relatively low modulus of elasticity. A built-up edge, however, does not form on tools used to machine titanium. Although this phenomenon accounts for the characteristically good finish on machined surfaces, it also leaves the cutting edge naked to the abrading action of the chips. In addition, titanium produces a thin chip which flows at high velocity over the tool face on a small tool-chip contact area. This, plus the high strength of

titanium produces high contact pressures at the tool-chip interface. This combination of events and the poor heat conductivity of titanium results in unusually high tool-tip temperatures.

TABLE 1. MACHINABILITY OF TITANIUM AND ITS ALLOYS RELATIVE TO OTHER SELECTED MATERIALS

Alloy	Type	Condi- tion ^(a)	Rat- ing ^(b)
2017	Aluminum alloy	T4	300
B1112	Resulfurized steel	HR	100
1020	Carbon steel	CD	70
4340	Alloy steel	A	45
Ti	Commercially pure	A	40
302	Stainless steel	A	35
Ti-5Al-2.5Sn	Titanium alloy	A	30
Ti-8Mn	Titanium alloy	A	25
Ti-6Al-4V	Titanium alloy	A	22
Ti-8Al-1Mo-1V	Titanium alloy	A	22
Ti-6Al-6V-2Sn	Titanium alloy	A	20
Ti-6Al-4V	Titanium alloy	HT	18
Ti-6Al-6V-2Sn	Titanium alloy	HT	16
Ti-13V-11Cr-3Al	Titanium alloy	A	16
Ti-13V-11Cr-3Al	Titanium alloy	HT	~12
HS25	Cobalt base	A	10
René 41	Nickel base	HT	6

(a) T4 = solution-heat-treated and artificially aged condition; HR = hot-rolled condition; A = annealed condition; HT = solution treated and aged condition.

(b) Based on AISI B1112 steel as 100.

Titanium's strong chemical reactivity with tool materials at high cutting temperatures and pressures favors galling, welding, and smearing. Abrasion by surface contamination or scale, if present, can notch cutting tools at the depth of cut line. Titanium's relatively low modulus of elasticity can cause slender parts to deflect more than steel, creating tolerance and tool-rubbing problems. In addition, titanium may shrink on steel drills, reamers, and taps because of differences in the thermal expansion of the materials involved.

It is desirable to use suitable cutting fluids properly applied. In general, it is suggested that chlorinated fluids and solvents should not be used wherever alternate nonchlorinated liquids are available. This is due to the possibility of encountering chloride stress corrosion, if the part retains residual chlorides on the surface and is subjected to subsequent heating. Where chlorinated cutting fluids are used, these should be removed promptly, for example, by using methyl ethyl ketone or acetone.

General Machining Requirements

Difficulties in machining titanium may be minimized considerably by providing a suitable cut-

*Research Metallurgist, Senior Research Metallurgist, and Division Chief, Metalworking Research Division; and Senior Chemical Engineer, Electrochemical Engineering Division, Battelle Memorial Institute, Columbus, Ohio.

environment. Basically, this means that high-quality machine tools, vibration-free rigid setups, and appropriate machining conditions should be used.

Machine tools used for various machining operations should exhibit the following characteristics:

	Mill	Turn	Drill	Tap
True running spindle	x	x	x	x
Excellent spindle bearings	x	x	x	x
Dynamic balance	x	x		
Flywheel-assisted speed drives	x			
Snug table gibs	x			
Backlash elimination	x	x	x	
Rigid frames	x	x	x	
Wide speed/feed ranges	x	x	x	x
Ample power to maintain speed	x	x	x	x
Easy accessibility for maintenance	x	x	x	x

The compositions of tool materials commonly employed in machining operations on titanium are listed in Tables 2 and 3.

Appropriate machining setups require strong, sharp cutting tools; positive feeds; relatively low cutting speeds; and certain types of cutting fluids.

Cutting tools should be properly ground. The face of the tool should be smooth, and the cutting edges free of feather burrs. Milling cutters, drills, and taps should be mounted to run true. Lathe tools should usually cut on dead center. In a multiple-tooth cutter like a mill or a drill, all teeth should cut the same amount of material.

All machining operations require a positive, uniform feed achieved mechanically. The cutting tool should never dwell or ride in the cut without removing metal. As an added precaution, all cutters should be retracted when they are returned across the work. The cutter should be up to speed and should maintain this speed as the cutter takes the load.

Vibration-free operation can be obtained by eliminating any looseness in power transmissions or excess play in slides or screws. Undersized or underpowered machines should be avoided. Certain aisle locations of machines near or adjacent to heavy traffic also can induce unwanted vibration and chatter during machining. Finally, improper cutter rigidity and/or geometry can contribute to vibration.

Rigidity of operation is a very important consideration for the successful machining of titanium. It is obtained through the use of adequate clamping and by minimizing deflection of work and tool during machining. In milling, this means machining close to the table, frequent clamping of long parts, and the use of backup blocks for thin walls. Rigidity in turning is achieved by machining close to the spindle, gripping the work firmly in the collet, and providing steady or follow rests for slender parts. Drilling requires short drills, positive clamping of sheet, and backup plates on through holes.

Cutting speed is the most sensitive factor in all machining operations. Excessive speeds cause over heating and consequent low tool life; hence, they are limited to relatively low values, unless adequate cooling can be supplied at the cutting site.

Health and Safety Considerations

No physiological reaction from titanium on the human body has been reported. However, a potential explosion hazard may exist if very finely divided titanium is present in the air in proper proportions.

The fire hazard is more real. Fine chips and turnings can be ignited under certain conditions. Titanium turnings also may ignite when the metal is cut at high speeds without the adequate use of coolants. In the same manner, dry grinding can cause trouble due to the intense spark stream. Finally, chip accumulations from poor housekeeping habits and improper storage produce likely sites for titanium fires. Systematic cleaning of machines, ducts, and floors, and the removal of titanium chips to isolated outside locations will alleviate the fire hazard situation.

TABLE 2. COMPOSITIONS OF HIGH-SPEED-TOOL STEELS^(a,b)

AISI Code ^(c)	Alloy Content, weight percent				
	Tungsten	Chromium	Vanadium	Cobalt	Molybdenum
T1	18	4	1	-	-
T4	18	4	1	5	-
T5	18-1/2	4	1-3/4	8	-
T6	20	4	2	12	-
T8	14	4	2	5	-
T15	14	4	5	5	-
M1	1-1/2	4	1	-	8
M2	6	4	2	-	5
M10	-	4	2	-	8
M3	6	4	2.75	-	5
M4	5.50	4	4	-	4.50
M6	4	4	1.5	12	5
M7	1.75	3.75	2.0	-	8.75
M30	2	4	1.25	5	8
M33	1.75	3.75	1.0	8.25	9.25
M34	2	4	2	8	8
M15	6.5	4	5	5	3.5
M35	6	4	2	5	5
M36	6	4	2	8	5
M41	6.75	4.25	2.00	5.00	3.75
M42	1.50	3.75	1.15	8.00	9.50
M43	1.75	3.75	2.00	8.25	8.75
M44	5.25	4.25	2.25	12.00	6.25

(a) Table taken from ASM Metals Handbook, Supplement, 22 (1954).

(b) For commercial listings, reference can be made to "A Guide to Tool Steels and Carbides", Steel (April 21, 1958).

(c) T1, M1, and M10 perform similarly for ordinary applications. When greater than average red hardness is needed, cobalt-containing grades are recommended. All grades in the molybdenum and tungsten groups are not necessarily comparable. Special-purpose steels such as T6, T8, T15, M6, M35, and M36 seem to have no close counterparts in the other groups. The unique compositions and properties of these steels suit them to certain applications without competition.

CONVENTIONAL MACHINING

Milling Operations

Introduction

Milling titanium parts can be troublesome. Galling of tools and the amount of titanium smeared on cutter edges is proportional to the chip thickness as each tooth leaves the cut. The smeared metal and part of the underlying cutting edge then chips off as each tooth re-enters the cut, thus starting a wearland. Galling increases progressively and wearland grows until tool failure occurs. This progressive tool chipping and wear phenomenon also produces a gradual surface-finish deterioration and a loss of tolerance. Both factors can become serious unless the worn or damaged tool is replaced.

Other problems to be faced include heat, deflection, and abrasion. Excessive cutting temperatures soften chips which can clog flutes and load relief surfaces. Deflection of thin parts and slender milling cutters promote rubbing and added heat. Abrasive oxide surfaces on titanium can notch the cutter at the depth-of-cut line.

Another problem in milling titanium, particularly in the case of extrusions, results from distortion through the release of stresses originally imposed by the basic mill processing operation. Distortion occurs when unequal amounts of metal are removed from opposite surfaces, or by the machining operation itself.

The smearing/chipping behavior can be minimized by providing thin exit chips characteristic of down milling. Lower speeds and light feeds also reduce chipping, and permit lower cutting temperatures. Water-base coolants also reduce cutting temperatures and hence minimize galling. Chemical removal of any oxide skin before machining will alleviate the abrasion problem. Stress relief after machining overcomes the distortion problem.

In spite of the difficulties described, milling operations can produce titanium parts in a

variety of shapes and sizes to aircraft standards of surface finish and dimensional accuracy. A surface finish of 63 μ inches or better is readily attainable and values as low as 17 μ inches are possible in finishing cuts. In spar milling, leg and web thickness, as well as section height dimensional tolerances can be held to ± 0.010 inch.

Milling Machines

Horizontal or vertical knee-and-column milling machines are commonly used for face-milling, end-milling, and pocket-milling operations. Heavy-duty fixed-bed milling machines also can be used for face milling and end milling.

Numerically controlled, vertical profile milling machines, or tracer-controlled milling machines are used for profile-and pocket-milling operations.

Generally speaking, 10 to 15 horsepower is usually sufficient for milling titanium. This means, for example, a No. 2 heavy-duty or a No. 3 standard knee-and-column milling machine. However, the large machines often needed to accommodate large parts may have as much as 25 to 50 horsepower available.

Milling Cutters, Design, and Quality

The choice of the milling cutter used depends on the type of machining to be done. Face mills, plain milling cutters, and slab mills are used for milling plane surfaces. End mills are used for light operations such as profiling and slotting. Form cutters and gang-milling cutters are used to produce shaped cuts. All cutters need adequate body sections and tooth sections to withstand the cutting loads.

Tool angles of a milling cutter should be chosen to promote unhampered chip flow and immediate ejection of the chip. The controlling angles in this regard are axial rake, radial rake, and corner angles. These combine to form the true rake angle and the angle of inclination.

TABLE 3. TOOL-MATERIAL GUIDE FOR CARBIDES

CISC ^(a) Grade	Partial List of Carbides ^(b) Made by Various Manufacturers													
	Adamas	Carbet	Carboloy	Firlomet	Firwhite	Kenna-Metal	Newcomer	Sandvik Coromant	Talide	Tungsten Alloy	Valenite	Vascoloy Ramet	Wesson	Willey
C-1	B	CA3	44A	FA5	H	K1	NC4	H1	C89	9	VC1	2A68,VR54	GS	E8,E15
C-2	A	CA4	883,860	FA6	HA	K6	NC3	H1	C91	9H	VC2	2A5,VR54	G1	E6
C-3	AA	CA7	905	FA7	HE	K8	NC2	H3	C93	9C	VC3	2A7	GA	E5
C-4	AAA	CAB	999	FA8	HF	K11	NC2	H5	C95	9B	VC4	2A7	GF	E3
C-5	DD	CA51	78C	FT3	TQ4	KM	NS65,NS4	S6,S4	S88	11T	VC5	EE,VR77	WS	945
C-5A	434	CA610	370	FT41,FT5	TXH	K21	--	S1P	S88X	9S	VC125	VR77,VR75	26	8A
C-6	D	CA609	78B	FT4	FXH,TA	K25	NS3	S2	S90	10T	VC6	VR75	WM	710
C-7	C	CA608	78	FT6	TXL	K5H	NS2,NS17	S1	S92	8T	VC7	E,VR73	WH	606
C-7A	548	CA606	350	FT61	T16,TXL	K4H	--	--	S92X	5S	--	VR73	WH	6A
C-8	CC	CA605	330	FT7	T31,WF	K7H	NS15	F1	S94	5S	VC8	EH	WH	509,41

(a) Carbide Industry Standardization Committee.

(b) For the same CISC grade, there seem to be no truly equivalent carbides of different brands. Where two carbide grades from the same manufacturer are shown for the same CISC grade, the first is sometimes recommended.

Notes:

(1) The following chip-removal applications have been used for the CISC grade indicated. It will be noted that some grades specify type of metal removal for which they are best suited.

- | | |
|---|--|
| C-1 Roughing Cuts - cast iron and nonferrous materials | C-5A Roughing Cuts and Heavy Feeds - steel |
| C-2 General Purpose - cast iron and nonferrous materials | C-6 General Purpose - steel |
| C-3 Light Finishing - cast iron and nonferrous materials | C-7 Finishing Cuts - heavy feeds - steel |
| C-4 Precision Boring - cast iron and nonferrous materials | C-7A Finishing Cuts - fine feeds - steel |
| C-5 Roughing Cuts - steel | C-8 Precision Boring - steel |

(2) This chart can function only as a guide. The so-called "best grade" may differ for each specific job even if the material being machined is the same. The final selection can be made only by trial and error. Instructions regarding the specific use and application of any competitive grade should be obtained directly from the manufacturer.

Rake angles are not especially critical. Some fabricators prefer 0-degree instead of positive rake angles to overcome a tendency of the cutter to dig in and to chip prematurely.

The use of a corner angle plus a small nose radius also provides a longer cutting edge. This distributes cutting forces over a greater area, thus causing less pressure. It also aids in dissipating the heat of cutting.

At lower speeds, relief angles around 12 degrees give longer tool life than do the standard relief angles of 6 or 7 degrees. If chipping occurs, the reliefs should be reduced toward the standard values. Generally, relief angles less than 10 degrees may lead to excessive smearing along the flank, while angles greater than 15 degrees weaken the tool and encourage "digging-in" as well as chipping of the cutting edge.

All cutters should be ground and mounted to run absolutely true in order to make the best use of the relatively light feeds used in milling titanium, and to make certain that all teeth are cutting the same amount of material. The total runout should be no more than 0.001-inch TIR.

Tool Materials

The choice of the proper tool material is not a simple matter in milling. The correct selection, in fact, depends on eight factors:

- The milling machine and its condition
- Type of cut and rigidity of setup
- The composition and hardness of the workpiece
- The shape and size of part
- The finish required
- The dimensional accuracy needed
- The desired metal-removal rate
- The skill of the operator.

Conventional high-speed steel cutters are popular and can be used in the following instances:

- Low production volume of small parts
- Slots and form cuts
- Milling under conditions of insufficient rigidity
- End mills, form mills, narrow side-cutting slitting saws, and large radius cutters.

Tool life is low by ordinary standards when milling titanium and it is quite sensitive to speed. Furthermore, some differences in the performance of high-speed steel cutters may exist between cutters of the same type and geometry but obtained from different suppliers. This difference can be attributed to composition and/or heat treatment of the tool. High-speed steel cutters, therefore, should be purchased to the specifications covering the grade and appropriate heat treatment of the steel.

A complete listing of high-speed steels is shown in Table 2.

Carbide-milling cutters are especially useful in high-production or extensive metal-removal operations, particularly in face-milling and slab-milling applications. Carbide milling is done extensively in the aircraft industry, and is recommended whenever possible because of the higher production rates attainable. However, carbide cutting tools require heavy-duty, vibration-free machines and rigid fixturing.

The success of carbide milling depends largely on general supervision and control. A qualified supervisor knowledgeable in carbide tooling should be responsible for the carbide-milling effort. Some competitive grades of carbides are identified in Table 3.

Feeds

Feed rates for milling titanium are usually limited to the range of 0.002 to 0.006 ipt to avoid overloading the cutters, fixtures, and milling machine. Light feeds at low speeds also help to reduce premature chipping. Delicate types of cutters and flimsy or nonrigid workpieces require smaller feeds. It is important to maintain a positive, uniform feed. Positive gear feeds without backlash are sometimes preferred over hydraulic feed mechanisms. Cutters should not dwell or stop in the cut.

Down-milling techniques are usually used for carbide and cast-alloy cutters to encourage formation of a thin chip.

Depth of Cut

The selection of cut depth depends on the part rigidity, the tolerances required, and the type of milling operation undertaken. For skin milling, light cuts (0.010 to 0.020 inch) seem to permit less warpage than deeper cuts (0.040 to 0.060 inch). When cleaning up extrusions, a 0.050-inch depth is usually allowed. However, depths of cut up to 0.15 inch can be used in other situations if sufficient power is available. When forging scale is present, the nose of each tooth must be kept below the scale to avoid rigid tool wear.

Cutting Speeds

Cutting speed is a very critical factor in milling titanium. Excessive speeds will cause overheating of the cutter edges and subsequent rapid tool failure. Consequently, one should not exceed the speeds shown in Tables 4, 5, and 6. In fact, when starting on a new job, it is advisable to use a cutting speed in the lower portion of the recommended range.

Sufficient flywheel-assisted spindle power should be present to maintain constant cutting speed as the cutter takes the cutting load.

Cutting Fluids

A wide variety of cutting fluids are used to reduce cutting temperatures and to inhibit galling. Sulfurized mineral oils are used extensively and are usually flood applied. Water-base cutting fluids are also widely used and are either flood or mist applied. Examples of the latter include:

- Water-soluble waxes
- Heavy-duty soluble oil emulsions (1:10 dilution)
- Rust-inhibitor types (Nitrite amine)
- Chemical coolants [Ba(OH)₂ in water]
- Certain proprietary coolants (Mobil TJ-73, Johnson TL-131, Cimplus, and others).

Tool life seems to be significantly improved when a 5 percent barium hydroxide-water solution is used as a spray mist. However, it seems advisable to exhaust the fumes from the cutting area to protect the operator.

TABLE 4. MILLING TITANIUM ALLOYS WITH HELICAL FACE MILLS^(a)

Cutter Material:	Carbide				High-Speed Steel			
	Ti-5Al-2.5Sn Machined:	Ti-6Al-1Mo-1V	Ti-6Al-4V Ti-7Al-4Mo Ti-6Al-6V-2Sn	Ti-13V-11Cr-3Al	Ti-5Al-2.5Sn	Ti-6Al-1Mo-1V	Ti-6Al-4V Ti-7Al-4Mo Ti-6Al-6V-2Sn	Ti-13V-11Cr-3Al
Tool Material Type	C-1 or C-2	C-1 or C-2	C-2	C-2	T15 or M15	M3	M3 or T15	T15
Tool Angles, degrees								
Axial Rake	0	+6 to -6	0	0 to +10	0 to +10	+6 to -6	0	10
Radial Rake	0 to -10	0 to -14	0	0 to +10	0 to +10	0 to -14	0	0 to +10
Corner	45 to 60	0	45	45	30 to 45	0	45	45
End-Cutting Edge	6 to 10	0	10	5 to 10	6 to 10	0	10	5 to 10
Relief	10 to 12	6	10	10	10 to 12	6	10	10
Tool Nose Radius, inch	0.04-0.125	0.04	0.04	0.04	0.04-0.125	0.04	0.04	0.04
Feed, ipt	0.002-0.012	0.005	0.004-0.006	0.003-0.006	0.002-0.008	0.005	0.004-0.006	0.004-0.006
Depth of Cut, inch	0.05-0.25	0.25-0.050	0.05-0.10	0.05-0.10	0.05-0.25	0.025-0.05	0.05-0.10	0.05-0.10
Speed, fpm								
Annealed Alloys	80-200	160-170	125-150	100-125	15-75	80	60	45
Aged Alloys	55-95	--	80-100	70-100	30-50	--	50	30
Cutting Fluids	Soluble oil-water emulsions	Soluble oil-water emulsions	Sulfurized mineral oil	Sulfurized mineral oil	Soluble oil-water emulsions	Soluble oil-water emulsions	Soluble oil-water emulsions	Soluble oil-water emulsions
Types	Water-soluble waxes	Chemical coolants	--	--	Water-soluble waxes	Chemical coolants	--	--
Application	Spray mist or flood	Spray mist	Flood	Flood	Spray mist or flood	Spray mist	Flood	Flood

(a) From References 1 to 7 inclusive; see page 8 for listing.

TABLE 5. MILLING TITANIUM ALLOYS WITH HELICAL END MILLS^(a)

Milling Operation	End Milling			Profile or Pocket Milling				
	High-Speed Steel			Profiling	Slotting	Corner Milling	Slotting	Corner Milling
Cutter Material:	High-Speed Steel			High-Speed Steel				Solid Carbide
Titanium Alloy Machined:	Ti-5Al-2.5Sn	Ti-6Al-4V Ti-7Al-4Mo Ti-6Al-6V-2Sn	Ti-13V-11Cr-3Mo	Ti-5Al-2.5Sn	Ti-6Al-1Mo-1V		Ti-6Al-1Mo-1V	
Tool Material Type	M3, Type 2	M2	M2	M3, Type 2	T5	T5	C-1 or C-2	C-1 or C-2
Tool Angles, degrees								
Helix	30	30	30	45	30	30	30	30
Radial Rake	0	0	0	10	0 to +4	0 to +4	0 to +4	0 to +4
Corner	--	--	--	--	--	--	--	--
End-Cutting Edge	--	--	--	--	--	--	--	--
Relief	10	10	10	4 to 15	6	6	12	12
Tool Nose Radius, inch	--	--	--	--	--	--	--	--
Feed, ipt	0.003-0.005	0.003-0.005	0.003-0.005	0.0015-0.003	0.002-0.004	0.004	0.002-0.004	0.004
Depth of Cut, inch	1/3 cutter diameter	1/3 cutter diameter	1/3 cutter diameter	--	--	--	--	--
Speed, fpm								
Annealed Alloys	60-70	50-60	30-40	10-30	50	70-90	200	200
Aged Alloys	--	30-40	20-25	--	--	--	--	--
Cutting Fluids	Heavy-duty water-soluble oil			Soluble oil-water emulsions or rust-inhibitor coolant, mist applied	Soluble oil-water (1:30 dilution) or barium hydroxide (5% solution) applied as a spray mist.			

(a) From References 1 to 7 inclusive; see page 8 for listing.

TABLE 6. SPAR- OR SLAB-MILLING TITANIUM ALLOYS^(a)

Cutter Material:	Carbide	
	Ti-8Al-1Mo-1V	Ti-6Al-4V Ti-7Al-4Mo Ti-6Al-6V-2Sn
Titanium Alloy Machined:		
Tool Material Type	C-2	C-2
Tool Angles, degrees		
Axial Rake	15	15
Radial Rake	0	0
Corner	--	--
End-Cutting Edge Relief	--	--
Relief	12	12
Tool Nose Radius, inch	--	--
Feed, ipm ^(b)	90-150	90-150
Depth of Cut, inch ^(c)	0.025-0.075	0.025-0.075
Speed, fpm		
Annealed Alloys	230-370	230-370
Aged Alloys	--	--
Cutting Fluids	Soluble oil-water emulsions (1:30 dilution) or barium hydroxide (5% solution) as a spray mist	

- (a) From Reference 5.
- (b) The unit feeds resulting from the linear feeds shown range between 0.004 to 0.12, ipt, depending on the finish desired. However, too light a feed can produce red-hot chips which can cause a fire hazard.
- (c) When cleaning up extrusions, only about 0.05 inch depth of cut can be taken in order to reduce material costs. Hence, for long parts, use the feed/speed combination which gives the most economical metal removal based on machines available and cutting-tool inventory.

Good tool life can be obtained by using the spray-mist technique for all water-base coolants. The mist should be applied ahead of a peripheral milling cutter (climb cutting), and at both the entrance and exit of a face-milling-type cutter. Pressurizing the fluid in an aspirator system permits better penetration to the tool-chip area, better cooling, and better chip removal.

There are a number of proprietary fluids in each category which are producing excellent results.

General Milling Techniques and Inspection

Machining titanium requires reasonably close supervision. This means that the supervisor should check all new milling setups before cutting operations begin. Thereafter, he should spot check for nicks and scratches to prevent defective parts from being processed too far.

The milling cutter also should be examined for early indications of dulling. If a dull red chip starts to form, the tool should be replaced. Some companies recommend at least two cutters for a given operation. Minimum downtime usually occurs when the entire cutter is replaced by a new one.

Surface contamination may break down cutters prematurely. If this is a problem, the abrasive surface can be removed by chemical cleaning.

Face-Milling Operations

Introduction

Face-milling operations employ the combined action of cutting edges located on the periphery and face of the cutter. The milled surface is generally at right angles to the cutter axis, and is flat except when milling to a shoulder. Face mills and end mills represent the tools used in this operation. Face mills are suitable for facing workpieces wider than 5 inches. End mills are used for facing narrow surfaces, and for operations such as profiling and slotting. The following tabulation shows the type of mills used in various operations. Figures 1 and 2 show the important tool angles involved.

Type Mill	Diameter	Application
Face mills ^(a)	6 inches and greater	Roughing and finishing
Shell end mills	1 to 6 inches	Facing wide surfaces
End mills	1/2 to 2 inches	Facing narrow surfaces End milling Profiling Slotting Slots
Slotting mills	1/2 to 2 inches	

(a) Indexable face-milling cutters using throwaway carbide inserts are available in positive or negative rakes with lead angles up to 45 degrees.

Face or Skin Milling

Conventional face mills are suitable for machining relatively wide flat surfaces. Typical designs include those of Futurmill, Ingersoll, and other makes. Special face mills are also used and include the rotating insert and conical types.

Diameters of face mills are important; they can range up to 6 inches, but should not be appreciably greater than the width of the cut. If a smaller diameter cutter can perform the operation and still overhang the cut by 10 percent, then a larger cutter should not be used. It is not good practice to bury the cutter in the work.

A good surface finish and freedom from distortion are always desirable. Surface finish, in the case of milling, seems to become considerably better with decreasing feed, and slightly better with increasing speed. Light cuts (0.010 to 0.020) on sheet metal seem to cause less warpage than deeper cuts (0.040 to 0.060 inch).

Table 4 contains data on feeds, speeds, depth of cut, and other variables important in milling titanium alloys.

Profile or Pocket Milling

Profile or pocket milling is done with end mills. Cutters are fed gradually into the work to keep them from grabbing and breaking. Chip crowding, chip disposal, and tool deflection can be problems during this machining operation.

Helical-type end mills give better performance than straight-tooth designs. When the end of the cutter is doing the cutting, the hand of the helix and the hand of the cut should be the same, i.e., right-hand helix for a right-hand cut. When the periphery of the cutter is doing the cutting, the opposite is true, i.e., left-hand helix for a right-hand cut.

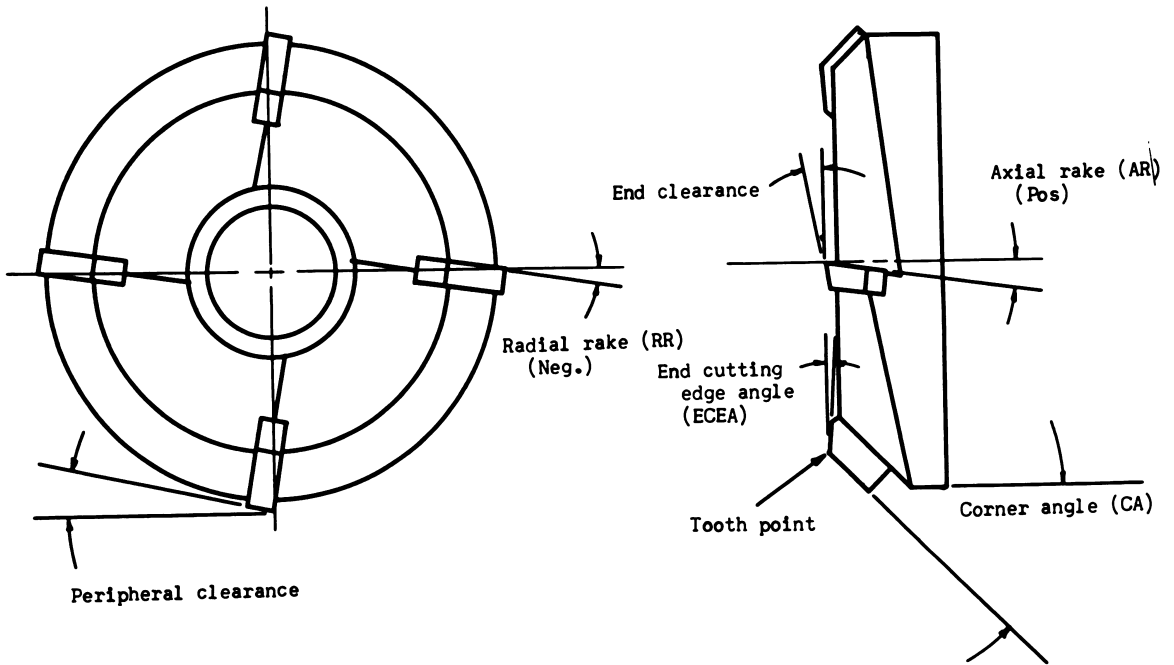

FIGURE 1. FACE-MILL NOMENCLATURE⁽⁷⁾

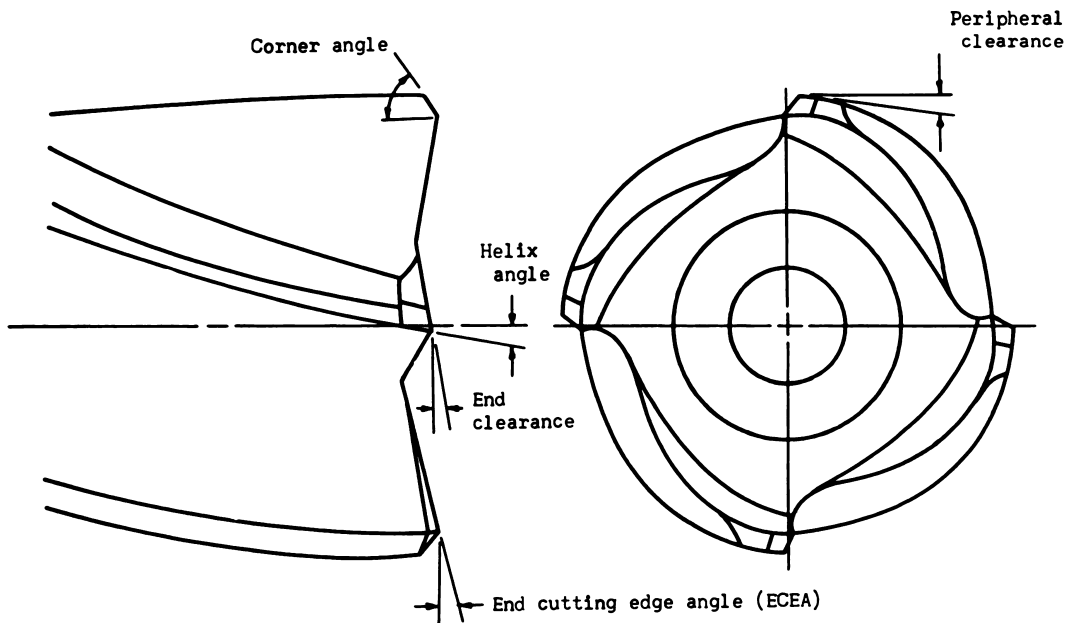

FIGURE 2. END-MILL NOMENCLATURE⁽⁷⁾

Cutter diameter in pocket milling depends on the radius needed on the pockets. Due to an inherent lack of rigidity, end mills should be as short as practicable, and their shank diameters should equal their cutting diameters.

The shank of end mills should be softer than the cutter flutes to avoid breakage between shank and flutes.

Table 5 provides cutting data on end milling, as well as on profile milling using high-speed steel and solid carbide cutters.

Peripheral Milling Operations

Introduction

Peripheral milling operations utilize the cutting action of teeth located on the periphery of the cutter body. Arbor-mounted cutters used for such operations include plain mills, helical mills, slab mills, form relieved cutters, formed profile cutters, die mills, and slotting cutters.

It should be noted, however, that face mills are usually more efficient in removing metal from flat surfaces and produce them more accurately than plain milling cutters do. Higher feed rates are so possible with face mills because they are more rigid. In addition, the complicated supports usually required for arbor-mounted cutters are unnecessary when face mills are employed.

Spur or Slab Milling

Spur or slab milling is used to bring extrusions into aircraft tolerance and to provide a good surface finish. The operation can be performed on heavy-duty fixed-bed mill like the Sundstrand rigid mill. Large bed mills, however, may not have adequate feed ranges.

Spurs and similar sections, being relatively long and thin, require special considerations. As received extrusions may need straightening before machining, since extrusion-straightness tolerances exceed mill fixture and part tolerances.

Rigid setups are necessary, but spur extrusions could not be forced into a fixture.

When using arbor-mounted cutters, the arbor should be of the largest possible diameter. Furthermore, the arbors should be supported on each side of the cutter with over-arm supports.

Slab-milling cutters should be mounted so that the cutting forces will be absorbed by the spindle of the machine. This is accomplished by using cutters with a left-hand helix for a right-hand cut, and vice versa.

When two milling cutters are used end-to-end in the arbor, cutters having helixes of opposite hand to the cut involved should be used. This set-neutralizes the cutting forces which tend to shift the cutters away from the arbor.

Carbide cutters are preferred because of the higher production rates attainable--except under conditions where the inherent brittleness of the

carbide precludes its use. Helical cutters are recommended. They provide wider and thinner chips than do the corresponding straight-tooth types. In slab milling, six cutting edges per inch diameter allows heavier feeds and longer tool lives than the conventional three cutting edges per inch diameter.

Table 6 gives machining data used for milling Ti-8Al-1Mo-1V and Ti-6Al-4V spars.

Selected References on Milling

- (1) Buhler, T. C., "The Machining and Grinding of Titanium Hydrofoils", R-130, The Miami Shipbuilding Corporation, Miami, Florida, for the U. S. Navy, Bureau of Ships, under Contract No. NObs 72245.
- (2) "Milling, Drilling, and Tapping the Difficult to Machine Materials", Metal Cutting Tool Institute, New York, New York (1958).
- (3) Gunter, J. L., "Determination of Adaptability of Titanium Alloys: Volume III. Processes and Parts Fabrication", Final Report AMC-TR-58-7-574, The Boeing Airplane Company, Seattle, Washington, for the U. S. Air Force under Contract AF 33(600)-33765 (December 1, 1958), AD 156058.
- (4) "Increased Production Reduced Costs Through a Better Understanding of the Machining Process and Control of Materials, Tools, and Machines", Volume IV, AMC-TR-60-7-532, Curtiss-Wright Corporation, Wood-Ridge, New Jersey, for the U. S. Air Force under Contract AF 33(600)-35967 (May, 1960).
- (5) Phillips, J. L., "Cutter Geometry, 8-1-1 Titanium", SAE National Aeronautic and Space Engineering and Manufacturing Meeting, Los Angeles, California (October 6, 1964).
- (6) Van Voast, J., "Increased Production Reduced Costs Through a Better Understanding of the Machining Process and Control of Materials, Tools, and Machines", Volume III, Curtiss-Wright Corporation, Wood-Ridge, New Jersey, for the U. S. Air Force under Contract AF 33(038)-9948 (1954).
- (7) Zlatin, N., Field, M., and Gould, J., "Machining of Refractory Materials", Volume VIII, ASD-TR-7-532a, Metcut Research Associates, Inc., Cincinnati, Ohio, for the U. S. Air Force under Contract AF 33(600)-42349, for the period August 1 to October 31, 1962 (November, 1962).

Turning and Boring Operations

Turning and boring operations on titanium are not particularly difficult when proper cutting conditions are used. The problems to be minimized include high tool-tip temperatures, and the galling and abrasive properties of titanium toward tool materials. They can be avoided by following the precautions listed in the section on "General Machining Requirements" and the suggestions given below. The conditions identified in this section for turning should be suitable for boring with single-point tools.

Turning Requirements

Lathes

A modern lathe in good condition provides production rates of five to ten times the rates possible with older machines. Vibration and lack of rigidity are common problems on older equipment.

Cutting Tools, Tool Design, and Tool Quality

Standard lathe tools are used for turning titanium. These are available in a variety of shapes, sizes, tool angles, and tool materials. High-speed steel, carbide, and cast-alloy tools can be used for titanium.

Tool angles are important for controlling chip flow, minimum smearing or chipping, and maximum heat dissipation.

Positive, zero, or negative rake angles can be used depending on the alloy, heat-treated condition, and machining operation. The side rake is the important angle; positive rakes are best for finish turning; negative rakes for carbide tools at heavier feeds.

Relief angles between 6 and 12 degrees can be used on titanium. Angles less than 5 degrees encourage smearing of titanium on the flank of the tool. Relief angles around 10 degrees are better, although some chipping can occur.

The side-cutting edge angle influences the cutting temperature near the cutting zone. Larger angles reduce cutting pressure and present longer tool edges. The reduced pressure minimizes heat formation; longer cutting edges allow a greater amount of heat dissipation. Hence, higher values of the side-cutting edge angle generally permit greater feeds and speeds—unless chipping occurs as the cutting load is applied or removed.

Chip-breaking devices should be used for good chip control.

Figure 3 explains the nomenclature used for single-point cutting tools.

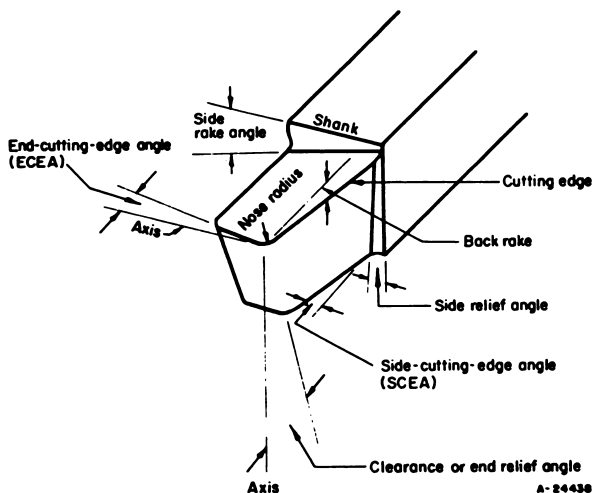

FIGURE 3. NOMENCLATURE FOR SINGLE-POINT CUTTING TOOLS

Cutting tools should be carefully ground and finished before use. Normally, this means that tool surfaces over which chips pass should possess a good finish, with the direction of finishing corresponding to the chip-flow direction. A rough surface can cause a properly designed tool to deteriorate rapidly.

Recommendations on tool geometry are given in Tables 7 and 8.

Tool Materials

Experience indicates that high-speed steel tools are best suited for form cutting, heavy plunge cuts, and interrupted cutting. Carbide tools are normally used for continuous cutting situations, high-production items, or extensive metal-removal operations. Nonferrous cast-alloy tools are suitable for severe plunge cuts, machining to dead center, and producing narrow grooves. Ceramic tools have not proved successful for titanium machining.

High-speed steel and cast-alloy tools can be ground to the tool geometry needed. The same is true for carbide tools; however, off-the-shelf brazed and throwaway carbide tools will fit the rake, lead, and relief angle requirements and are convenient to use.

Feeds

The three cardinal rules for feeding practice when turning titanium are:

- Always use constant, positive feeds
- Avoid dwelling in the cut
- Never stop or slow up in the cut.

The metal-removal rate and surface-finish requirements will determine the amount of feed to be taken—heavy feeds for higher metal-removal rates, light feeds for better surface finishes.

Recommendations on feeds are given in Tables 7 and 8.

Depth of Cut

The choice of cut depth will depend on the particular situation and the metal removal rate desired. For rough cuts, machine below any hard oxide skin remaining from previous processing. For finishing operations, use light cuts for the best surface finish and closest tolerances. Appropriate cut depths are mentioned in Tables 7 and 8.

Cutting Speed

Tool life when turning titanium is more sensitive to cutting speed than to any other machining variable. However, and fortunately for titanium, high speeds are not necessary for producing good finishes. Hence, relatively low cutting speeds are used to obtain reasonable tool life for a given tool material.

Cutting Fluids

Cutting fluids are almost always used during turning and boring operations to cool the tool and to aid in chip disposal. Dry cutting is done in only a very few instances, usually where chip contamination is objectionable. Dry cutting is not

TABLE 7. TURNING TITANIUM ALLOYS WITH CARBIDE TOOLS^(a)

Titanium Alloy Machined:	Rough Machining			Finish Machining	
	Ti-5Al-2.5Sn	Ti-6Al-4V	Ti-13V-11Cr-3Al	Ti-5Al-2.5Sn	Ti-6Al-4V
Tool Material Type	C-1 Throwaway Type <u>SBI</u>	C-2 Braze Type A; Throwaway Type <u>IAP</u>	C-2 Throwaway Type <u>SETI</u>	C-2 Braze Type B; Throwaway Type <u>SBP</u>	C-2 Braze Type A or B; Throwaway's <u>TGP, SBP, IAP</u>
Tool Angles, degrees					
Back Rake	+5 to -5	+5 to -5	-5	+5 to -5	0 to +10
Side Rake	0 to -6	+5	-5	+6 to -6	0 to +10
End Relief	5 to 10	8 to 10	5	5 to 10	6 to 8
Side Relief	5 to 10	8 to 10	5	5 to 10	6 to 8
End-Cutting Edge	6 to 10	5 to 10	45	6 to 15	5 to 10
Side-Cutting Edge	5 to 20	0 to 45	45	5 to 20	0 to 30
Tool Nose Radius, inch	0.03-0.045	0.03-0.04	1/32	0.03-0.045	0.06-0.10
Speed, ipr	0.015	0.003-0.015	0.0075	0.006-0.015	0.002-0.006
Depth of Cut, inch	0.10-0.25	0.060-0.20	0.10	0.03-0.10	0.001-0.030
Speed, fpm					
Annealed Alloys	100-120	70-150	--	130-200	150-350
Forged Alloys	--	--	100	--	--
Cutting Fluids	<-----See text----->			Barium Hydroxide (5% solution)	<-----See text----->

^(a) From References 1 to 7 inclusive, see page 11 for listing.

TABLE 8. TURNING TITANIUM WITH HIGH-SPEED STEEL TOOLS^(a)

Titanium Alloy Machined:	Rough Machining		Finish Machining		
	Ti-5Al-2.5Sn	Ti-6Al-4V	Ti-5Al-2.5Sn	Ti-6Al-4V	Ti-13V-11Cr-3Al
Tool Material, AISI Type	T5, T15	T5	T5, T15	T5	T15
Tool Angles, degrees					
Back Rake	0 to +5	+6 to +10	0 to +5	+5 to +15	0
Side Rake	+5 to +15	0 to +15	+5 to +15	+10 to +20	+5
End Relief	5 to 7	6 to 10	5 to 7	5 to 8	5
Side Relief	5 to 7	6 to 10	5 to 7	5 to 8	5
End-Cutting Edge	5 to 7	5 to 15	5 to 6	5 to 15	15
Side-Cutting Edge	+15 to +20	0 to 45	10 to 20	0 to 30	15
Tool Nose Radius, inch	0.02-0.03	0.03-0.04	0.02-0.03	0.01-0.06	0.03
Speed, ipr	0.015-0.050	0.003-0.015	0.008	0.002-0.006	0.008-0.010
Depth of Cut, inch	0.10-0.25	0.06-0.20	0.060	0.001-0.030	0.015-0.10
Speed, fpm					
Annealed Alloys	30	35-70	30-60	50-100	30-40
Forged Alloys	--	--	--	--	20-25
Cutting Fluids	<-----See text----->				Barium hydroxide (5% solution)

^(a) From References 1 to 7 inclusive, see page 11 for listing.

Recommended for semifinishing and finishing operations on titanium.

Water-base coolants are the most satisfactory cutting fluids used for turning titanium. Specifically, a 5 percent solution of sodium nitrite in water gives the best results, while a 1:20 soluble oil in water emulsion is second best. Sulfurized oils may be used, but precautions must be taken to avoid possible fires. A full, steady flow of cutting fluid should be maintained at the cutting site.

Control and Inspection

When setting up a turning operation, the work should be firmly chucked in the collet of the spindle and supported by the tail stock using a live center. The tool should be set to cut on dead center.

During machining, chips should be expelled from the work area as promptly as possible, particularly during boring. Chips lying on the surface tend to produce chatter and poor surface finishes.

The tool should be examined frequently for nicks or worn flanks. These defects promote galling, increase cutting temperature, accelerate tool wear, and increase residual stresses in the machined surface.

Arbitrary tool-changing schedules are desirable. Usually this means replacing carbide tools after 0.015-inch wearland in rough turning, and 0.010-inch wearland in finish turning. High-speed steel tools are replaced after a wearland of 0.030 inch is developed. When periodic interruptions are made in a machining operation, before the maximum wearland occurs, remove any welded-on metal, nicks, and crevices by honing.

Finally, it may be necessary to stress relieve all finish-machined parts.

Data on speeds, feeds, and depth of cut for carbide and high-speed steel tools are shown in Tables 7 and 8, respectively.

Selected References on Turning

- (1) Flanagan, S. H., "Single Point Turning of Titanium", Paper presented at the American Society for Metals Titanium Conference, Los Angeles, California, March 25-29, 1957 (1958).
- (2) Hill, F. S., "Evaluation of Ceramic Tools for Turning Titanium, Inconel, and Mild Steel", Report No. 6, Westinghouse Electric Corporation, Kansas City, Missouri (February 14, 1957).
- (3) "Increased Production, Reduced Costs Through a Better Understanding of the Machining Process and Control of Materials, Tools, and Machines", Volume IV, AMC-TR-60-7-532, Curtiss Wright Corporation, Wood-Ridge, New Jersey, for the U. S. Air Force under Contract AF 33(600)-35967 (May, 1960).
- (4) Stewart, I. J., "Machining Characteristics of Aged Titanium Alloy 13V-11Cr-3Al", Paper No. 505D presented at the National Aeronautics Meeting of the Society of Automotive Engineers, New York, New York, April 3-6, 1962.
- (5) "Titanium Billets Turned with Increased Know-How", Machinery, 67 (4), 141-144 (December, 1960).
- (6) Van Voast, J., "Increased Production Reduced Costs Through a Better Understanding of the Machining Process and Control of Materials, Tools, and Machines", Volume IIIa, Curtiss Wright Corporation, Wood-Ridge, New Jersey, for the U. S. Air Force under Contract AF 33(038)-9948 (1954).
- (7) Zlatin, N., Field, M., and Gould, J., "Machining of Refractory Materials", Volume VIII, ASD-TR-7-532a, Metcut Research Associates, Inc., Cincinnati, Ohio, for the U. S. Air Force under Contract AF 33(600)-42349, for the period August 1 to October 31, 1962 (November, 1962).

Drilling Operations

Introduction

Titanium is difficult to drill by techniques considered conventional for other materials. The usual galling action of titanium, accentuated by high cutting temperatures and pressures, produces rapid tool wear. Out-of-round holes, tapered holes,

or smeared holes are the probable results, with subsequent tap breakage if the holes are to be threaded.

These problems can be minimized by

- Using short, sharp drills
- Supplying cutting fluid to the cutting zone
- Employing low speeds and positive feeds
- Supplying solid support to the workpiece, especially on the exit side of the drilled hole where burrs otherwise would form.

Drilling Requirements

Machine Tools for Drilling

Machines for drilling operations are made in many different types and sizes. Size or capacity is generally expressed either in terms of the largest diameter disk, the center of which is to be drilled, or in horsepower. Heavy-duty machines are exceptions. They are specified as the distance from the supporting column to the centerline of the chuck. The horsepower rating is that usually needed to drill cast iron with the maximum drill diameter. Suitable sizes of machines for drilling titanium include:

- Upright Drill No. 3 or No. 4
- Upright Drill, Production: 21-inch, heavy duty, 5 hp
- Upright Drill, Production: 24-inch, heavy duty, 7-1/2 hp
- Upright Drill, Production: 28-inch, heavy duty, 10 hp.

Industry also has requirements for drilling parts at assembly locations. These needs are fulfilled by portable power-feed, air drilling machines. Modern units incorporate positive mechanical-feed mechanisms, depth control, and automatic return. Some are self-supporting, and self-indexing. Slow-speed, high-torque drill motors are needed. Spindle speeds between 230 and 550 rpm at 90-psi air pressure seem appropriate for high-speed drills, while speeds up to 1600 rpm have been used for carbide drills. Thrusts between 320 and 1000 pounds are available on some portable drilling machines.

Typical air-feed drill units include the Keller Air Feed and Winslow Spacematic.

Drills and Drill Design

The choice of drills depends on the drilling operation undertaken. A heavy-duty stub-type screw machine drill is recommended for drilling operations on workpieces other than sheet. For deep-hole drilling, oil feeding drills, or a series of short drill of various lengths, may be employed in sequence. Aircraft drills like NAS 907 Types B, D, and E, are usually used on sheet metal.

Drills having conventional drill geometry and special point grinds are used. This means a normal helix of around 29 degrees, just enough relief to prevent rubbing and pickup, a thinned web to reduce drilling pressure, a correct point angle with its apex held accurately to the centerline of the drill,

and cutting lips of the same slope and of equal length. Special point grinds include crankshaft notch-type drills, and split points with positive rake notching. When thinning the web, be sure not to alter the effective rake angle.

Figures 4 and 5 illustrate typical nomenclature for standard and NAS 907-type drills.

Drill Materials

Conventional molybdenum-type high-speed steels are usually used in production. Cobalt high-speed steels can give up to 50 percent more tool life; however, their costs are 1-1/2 to 2 times higher than standard high-speed steels.

Feeds

The philosophy of drilling titanium is to keep the drill cutting. Never allow the drill to ride in the hole without cutting metal. The best techniques are to utilize a positive mechanical feed. Even assembly drilling of sheet should be done with portable power drills having positive feed arrangements. Hand drilling can be done, provided sufficient thrust can be applied to insure a heavy chip throughout drilling.

Drilling Speeds

Since the cutting zone is confined, drilling requires low cutting speeds for minimum cutting temperatures. Speeds should remain constant throughout the course of drilling. This means an "over-powered" drilling machine. Low-speed, high-torque drill motors should be used for portable power drills.

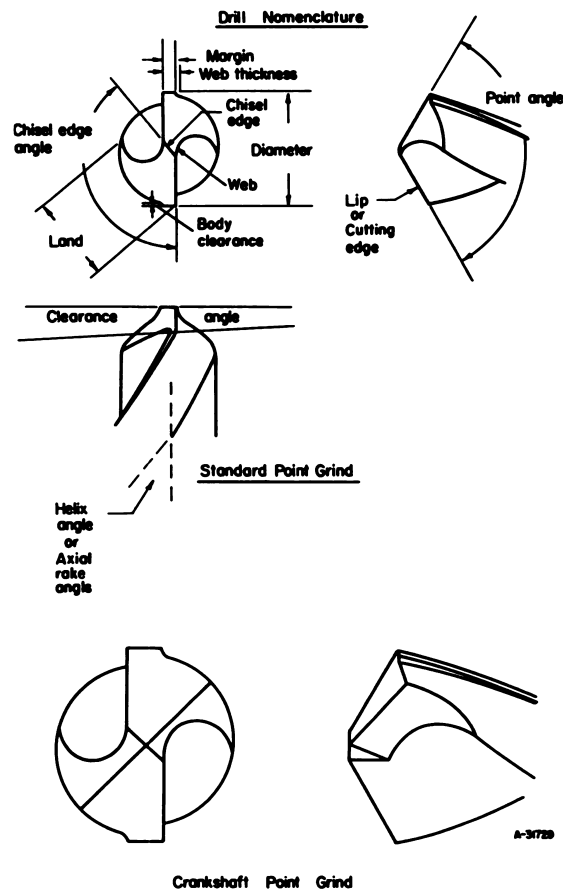

FIGURE 4. DRILL NOMENCLATURE AND ILLUSTRATION OF TWO TYPES OF DRILL-POINT GRINDS

Cutting Fluids

Drilling titanium usually requires the use of cutting fluids. Although holes in single sheets with thicknesses up to two times the drill diameter can be drilled dry; sulfurized oils, or sulfurized lanolin paste, are recommended for low speeds and for drills less than 1/4 inch in diameter. A good coolant like soluble oil-water emulsions can be used for the higher drilling speeds. Cooling action appears to be more important than lubricity.

A steady, full flow of fluid, externally applied at the cutting site, can be used, but the use of a spray mist seems to give better tool life. However, a two-diameter depth limit seems to exist for external applications. Hence, oil-feeding drills work best for deep holes.

General Drilling Techniques and Inspection

When starting a drilling operation, the drill should be up to speed as it advances toward the work. Never start with a dull drill; and use a triangular centerpunch to mark the hole location on the part. Drill holes to size in one operation whenever possible. Center drills, or undersize starting drills, are usually not recommended. The use of drill bushings is desirable for close-tolerance holes.

The margin of the drill should be examined periodically for smearing in order to prevent oversized holes. Also look for possible breakdowns that might occur at the outer corner of the lips. An arbitrary drill replacement point should be established to prevent work and drill spoilage.

Chips should be removed at periodic intervals unless the cutting fluid successfully flushes away the chips.

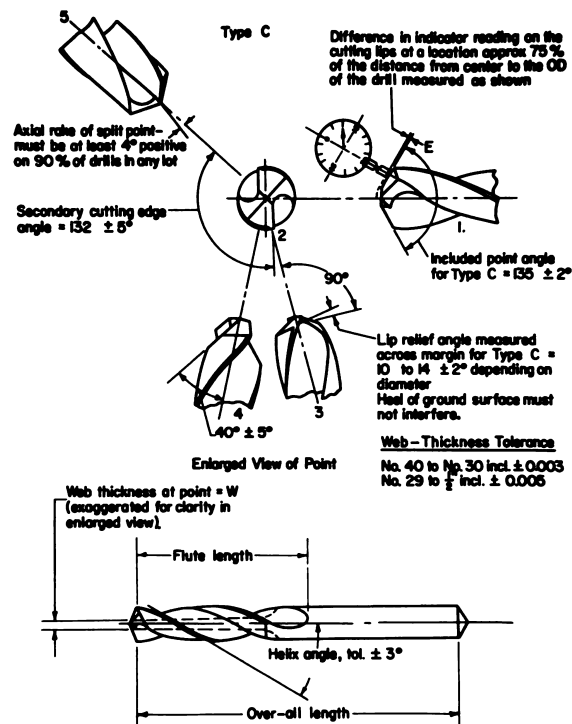

FIGURE 5. NAS 907 TYPE C AIRCRAFT DRILLS

When drilling holes more than one-diameter deep, retract the drill once for each half diameter of drill advance to clear the flutes. Retract simultaneously with the stop of the feed to minimize dwell. Re-engage drill quickly, but carefully, with the drill up to speed and under positive feed.

When drilling "through holes" do not drill all the way through on a continuous feed. Instead, retract drill before breakthrough and flush the drill and hole to remove the chips. Then return drill under positive feed and drill through carefully avoiding any "feed surge" at breakthrough.

All assembly drilling should be done using portable, fixed-feed, jig-mounted drilling machines. Hand drilling can be used, but the practical limit appears to be the No. 40 drill. Above this diameter, insufficient feed is the result with consequent heat buildup and short drill life. Furthermore, the high axial thrust required to keep the drill cutting causes rapid operator fatigue. Another problem with hand drilling is the combination of high thrust and uncontrollable feed rate to produce "feed surge" at breakthrough--and possible fractured cutting lips on the drill.

Drilled holes will require reaming to meet the tolerances of Class I holes, unless a bushing is used immediately adjacent to the part. Drilled holes in sheet will probably require exit-side deburring.

Operating data for drilling may be found in Table 9.

Selected References on Drilling

- (1) DiGregorio, A. E., "Drilling Machines", Paper No. 398, Volume 62, Book 1, American Society of Tool and Manufacturing Engineers (1962).
- (2) Gunter, J. L., "Determination of Adaptability of Titanium Alloys: Volume III--Processes and Parts Fabrication", AMC-TR-58-7-574, The Boeing Airplane Company, Seattle, Washington, for the U. S. Air Force under Contract AF 33(600)-33765 (December 1, 1958), AD 156058.
- (3) Haggerty, W. A., "The Effect of Drill Symmetry on Performance", Paper No. 254, Volume 60, Book 1, American Society of Tool and Manufacturing Engineers

TABLE 9. DRILLING DATA FOR TITANIUM ALLOYS^(a)

Type of Drilling	General Drilling and Deep Holes	Sheet Drilling
Machine tool	Radial drilling machine Upright drilling machine	Air-feed drill units Air-feed-oil check drill units
Type high-speed steel drills (AISI designations)	M7, M10, M33, M34 T4, T5	M1, M3 Type 2, M10, M36 T4, T5
Drill types	Standard twist drills	NAS 907 aircraft drills ^(b)
<u>Drill Geometry:</u>		
Helix angle, degrees	29	25 to 28
Clearance angle, degrees	7 to 12	10 to 18
Point angle, degrees	118 or 135	135
Web ⁽⁹⁾	?	Thin web one-half
Type point	Crankshaft or split point	Split point
<u>Drilling Data - Feed, ipr</u>		
Drilling Diameter, inch		
<1/8	0.0015	x
1/8 - 1/4	0.002-0.005	0.002-0.005
1/4 - 1/2	0.004-0.009	0.002-0.009
<u>Drilling Data - Speed, fpm^(c)</u>		
Alloy and Condition		
Unalloyed Titanium	40 to 80	40
Ti-8Al-1Mo-1V, annealed	x	40
Ti-6Al-4V, annealed	30 to 40	30
Ti-6Al-4V, aged	20 to 30	25
Ti-4Al-3Mo-1V, annealed	x	25
Ti-4Al-3Mo-1V, aged	x	20
Ti-13V-11Cr-3Al, annealed	20 to 30	x
Ti-13V-11Cr-3Al, aged	15 to 20	x
Cutting Fluids: ^(d)	Sulfurized oils (flood applied) Sulfurized lanolin paste Water-soluble types (spray mist)	Sulfurized oils (flood applied) Water-soluble types Dry (single sheets only)

(a) From References 1 to 13 inclusive, see pages 13 and 14 for listing.

(b) For hand drilling - NAS 907 Type D with P-3 point and lip rate reduced to zero. For fixed-feed drilling - NAS 907 Type B with P-3 point and lip rate reduced to zero. For fixed-feed drilling - NAS 907 Type E with P-2 point (dry).

(c) Use reduced speeds for deep holes.

(d) Sulfurized oils or sulfurized lanolin paste are recommended for low speeds and for drills less than 1/4 inch in diameter; water-soluble coolants can be used for higher speeds. Holes in single sheets up to two times the drill diameter can be drilled dry. Oil-feeding drills for deep holes.

- (4) "Increased Production Reduced Costs Through a Better Understanding of the Machining Process and Control of Materials, Tools, and Machines", Volume IV, AMC-TR-60-7-532, Curtiss Wright Corporation, Wood-Ridge, New Jersey, for the U. S. Air Force under Contract AF 33(600)-35967 (May, 1960).
- (5) Langlois, A. P., Murphy, J. F., and Green, E. D., "Titanium Development Program Volume III", ASD-TR-61-7-576, General Dynamics Corporation, Convair Division, San Diego, California, for the U. S. Air Force under Contract AF 33(600)-34876 (May, 1961).
- (6) Mathewson, C. and Janz, F. A., "Tips on Machining Titanium", American Machinist/Metalworking Manufacturing, 105 (14), 83-84 (July, 1961).
- (7) Meany, W. J., and Morehouse, D., "Developing a Fast Method for Drilling and Tapping Titanium", Light Metal Age, 17 (9,10), 12-13, 18 (October, 1959).
- (8) "Milling, Drilling, and Tapping the Difficult to Machine Materials", Metal Cutting Tool Institute, New York, New York (1958).
- (9) Myers, D. E., "DOD High-Strength Titanium Alloy Sheet Research Program", Report No. NA57H-527-10, North American Aviation, Inc., Columbus, Ohio, for the U. S. Navy under Contract NOAs 57-785d (January 28, 1960), AD 233295.
- (10) Phillips, J. L., "Cutter Geometry, 8-1-1 Titanium", SAE National Aeronautic and Space Engineering and Manufacturing Meeting. Los Angeles, California, October 6, 1964 (published by The Boeing Company).
- (11) Stewart, I. J., "Machining Characteristics of Aged Titanium Alloy 13V-11Cr-3Al", Paper No. 505D, National Aeronautics Meeting of the Society of Automotive Engineers, New York, New York, April 3-6, 1962.
- (12) Van Voast, J., "Increased Production Reduced Costs Through a Better Understanding of the Machining Process and Control of Materials, Tools, and Machines", Volume III, Curtiss Wright Corporation, Wood-Ridge, New Jersey, for the U. S. Air Force under Contract AF 33(038)-9948 (1954).
- (13) Zlatin, N., Field, M., and Gould, J., "Machining of Refractory Materials", Volume VIII, ASD-TR-7-532a, Metcut Research Associates, Inc., Cincinnati, Ohio, for the U. S. Air Force under Contract AF 33(600)-42349, for the period August 1 to October 31, 1962 (November, 1962).

Tapping Operations

Introduction

Tapping titanium is a difficult operation. The limited chip flow inherent in taps, and the severe galling action of titanium can result in poor threads, improper fits, excessive tap seizures, and broken taps. Titanium also tends to shrink on the tap at the completion of the cut.

Tapping difficulties can be minimized by reducing the thread requirements to 55 to 65 percent full thread,* and then tapping the fewest threads that the design will allow. Designers should also avoid specifying blind holes or through holes of excessive lengths. In both cases, the chips are confined and can cause rough threads and broken taps. Some relaxation in class-of-fit tolerances also should be considered.

The tapping operation, itself, requires sharp taps of modified conventional design, low tapping speeds, and an effective tapping lubricant.

Tapping Requirements

Tapping Machines

A lead screw tapping machine is recommended to insure proper lead, a regulated torque, and a uniform hole size. Lead screw tapping heads should be equipped with friction clutches. The clutch should prevent tap breakage when galling occurs, since a very small amount of smear may result in immediate tap breakage.

Tapping machines should be rigid, accurate, and sensitive. Machine tapping, unless done on a sensitive machine, can result in excessive tap breakage and poor-quality work.

Setup Conditions

The setup conditions for tapping should closely parallel those for drilling. Hand tapping lacks the required rigidity and is extremely slow and difficult.

Taps and Tap Design

Gun taps have been used successfully. Chip driving spiral point taps with interrupted threads and full eccentric relief also have been successful. Taps should be precision ground and stress relieved. Two-fluted taps are usually used for 5/16-24 holes and smaller, while three-fluted taps are best for 3/8-16 holes and greater, and for other tapping situations. Taps with 2 flutes normally do not give the support the three-fluted taps provide.

If rubbing is encountered during tapping, it may be decreased by:

Using interrupted threads with alternate teeth missing

Grinding away the trailing edge of the tap

Grinding axial grooves in the thread crests along the full length of the lands

Employing either eccentric or concentric thread relief.

Taps should have tool angles suitable for titanium. This usually means:

A spiral point angle large enough to allow chip flow out of the hole ahead of the tap

*Some companies, however, have successfully tapped 75 percent threads.

A relief angle large enough to prevent seizure but not so large as to cause jamming when backing out the tap. An eccentric pitch-diameter relief also can be used successfully

Sufficient cutting rake to provide a good shearing action

A chamfer of around 3 threads to provide a small depth of cut. A shorter chamfer results in high torque and possible tap breakage. A long chamfer produces long, stringy chips which may jam the tap during back-out operations. However, a plug chamfer gun tap can be used for shallow holes (holes less than one tap diameter deep).

Figure 6 illustrates the tap nomenclature referred to above.

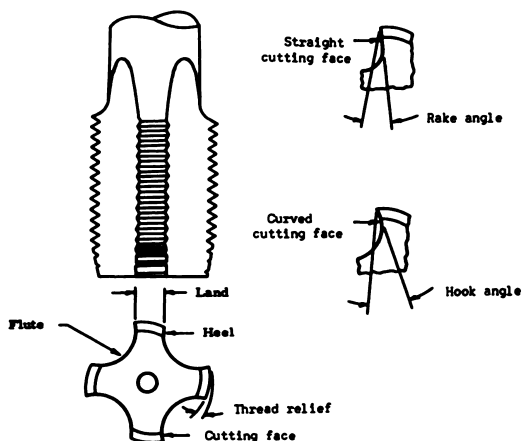

FIGURE 6. TAP NOMENCLATURE (8)

Surface treatments of the tap contribute to successful tapping by reducing galling and increasing resistance to abrasion. Nitriding, oxide coating, or chromium plating have been used successfully.

Tap Materials

High-speed steel taps are used, AISI-T1 for tapping commercially pure titanium and AISI-M10 for titanium alloys.

Size of Cut Requirements

The size of cut is determined by the chamfer given the tap. The chamfer which produces small chips without jamming the tap during the backing-out phase should be used.

Tapping-Speed Requirements

It is important to limit the tapping speeds to those shown in Table 10, as cutting torque increases extremely rapidly beyond a certain threshold speed.

The high-strength titanium alloys require lower tapping speeds than the lower strength alloys,

and much lower speeds than commercially pure titanium.

TABLE 10. TAPPING DATA FOR TITANIUM ALLOYS (a)

Type High-Speed Steel: Type Hole Tapped:	AISI-T1, AISI-M1, or AISI-M10			
	Through		Blind	
Hole Depth, tap diameters	One or less	>1	One or less	>1
Type Tap Used	GH-3 gun	Spiral	Plug or bottom	Plug and bottom(b)
Number Flutes				
For 5/16-24 tap and smaller	2	3	4	4
For 3/8-16 tap and greater	3 or 4	4	4	4
Chamfer, number of threads	Plug	2-1/2-3	--	--
Tool Angles, degrees				
Spiral point angle	--	10-17	--	--
Spiral angle	--	110	--	--
Relief angle	--	2 to 4	--	--
Cutting rake angle	Standard	6 to 10	--	--
Tapping Speeds, fpm				
Unalloyed titanium	--	40 50	--	--
Titanium alloys	--	10-30	--	--
Ti-6Al-4V, annealed	--	10-20	--	--
Ti-6Al-4V, aged	--	5-10	--	--
Ti-8Al-1Mo-1V, annealed	10-12	10-12	--	--
Ti-13V-11Cr-3Mo, annealed	--	8-10	--	--
Ti-13V-11Cr-3Mo, aged	--	5-7	--	--
Cutting Fluids or Tapping Compounds	-----See text----->			

(a) From References 1 to 7 inclusive, see page 16 for listing.
 (b) Where no clearance exists, use plug tap first to start threads, and then use bottom tap to chase threads.

Cutting Fluids

The selection of cutting oils and compounds is extremely important because of the susceptibility of taps to seizure.

The paste-type cutting compounds usually give the best results, while a heavily sulfurized mineral oil is the next best.

Sulfurized oil, flood applied, is also satisfactory for tapping titanium. Soluble oils, however, are usually considered most satisfactory.

General Tapping Techniques and Inspection

As a first requirement, holes for tapping should have been produced by sharp drills operating under proper drilling conditions. Dull drills produce surface-hardened holes which will magnify tapping difficulties. Sharp, clean taps must be used at low tapping speeds with recommended tapping compounds and under rigid tool-work setups. A stiff nylon brush pressed against the top of the return stroke will help to remove chips and has been reported to increase tap life by at least 50 percent.

Where holes require complete threads close to the bottom of the hole, a series of two or three taps with successively shorter chamfers may be required.

Taps should be inspected carefully after use on six holes for possible smearing of lands. These smears may be hard to see, but if present, can cause premature tap breakage and oversized holes. The workpiece also should be inspected for possible torn threads and dimensional discrepancies. It should be remembered that most tapping is done on parts which are 80 to 90 percent finished; hence, scrap from tapping operations can be very costly.

Selected References on Tapping

- (1) "Increased Production Reduced Costs Through a Better Understanding of the Machining Process and Control of Materials, Tools, and Machines", Volume IV, AMC-TR-60-7-532, Curtiss Wright Corporation, Wood-Ridge, New Jersey, for the U. S. Air Force under Contract 33(600)-35967 (May, 1960).
- (2) Mathewson, C., and Janz, F. A., "Tips on Machining Titanium", American Machinist/Metalworking Manufacturing, 105 (14), 83-84 (July, 1961).
- (3) Meany, W. J., and Morehouse, D., "Developing a Fast Method for Drilling and Tapping Titanium", Light Metal Age, 17 (9,10), 12-13, 18 (October, 1959).
- (4) "Milling, Drilling and Tapping the Difficult to Machine Materials", Metal Cutting Tool Institute, New York, New York (1958).
- (5) Phillips, J. L., "Cutter Geometry, 8-1-1 Titanium", SAE National Aeronautics and Space Engineering and Manufacturing Meeting, Los Angeles, California, October 6, 1964 (Published by The Boeing Company).
- (6) Stewart, I. J., "Machining Characteristics of Aged Titanium Alloy 13V-11Cr-3Al", Paper No. 505D, National Aeronautics Meeting of the Society of Automotive Engineers, New York, New York, April 3-6, 1962.
- (7) "Tapping 8-1-1 Titanium", Report No. MDR2-22265, The Boeing Company, Seattle, Washington (April 1, 1964).
- (8) Zlatin, N., Field, M., and Gould, J., "Machining of Refractory Materials", Volume VIII, ASD-TR-7-532a, Metcut Research Associates, Inc., Cincinnati, Ohio, for the U. S. Air Force under Contract AF 33(600)-42349, for the period August 1 to October 31, 1962 (November, 1962).

GRINDING TITANIUM

Precision Wheel Grinding

Introduction

Titanium and its alloys can be ground at about the same rate as hardened high-speed steels and die steels. Moderately light cuts are recommended, and periodic dressings are required to keep the wheel in proper condition. Excessive wheel loading leads to poor grinding action and causes poor surface finish, high residual tensile stresses, and low grinding ratios.

Wheel wear can occur by attrition, which causes flat spots on individual grains; by grain fractures, which expose new and sharp cutting points and edges; and by bond fracture, which causes abrasive grains to leave the wheel individually or in clusters. These phenomena occur regardless of the material ground, and the relative amount of each contributing factor depends on grinding conditions and the material itself. Wear by the attrition that is associated with titanium's chemical reactivity toward abrasives becomes excessive only when titanium is ground improperly.

Loading, a phenomenon by which a metal being ground is deposited on or between the abrasive grains, or both, can occur whether the wheel is sharp or dull, although dulling will intensify the loading process. As loading continues, the grinding action decreases until burnishing occurs. Then the grinding temperature rises and causes high residual tensile stresses in the ground surface and generally an unsatisfactory surface finish.

Titanium can crack when ground under the conditions normally used for production steels. Under proper grinding conditions for titanium, however, grinding cracks are no longer the problem they were when alloys were not of the present high quality. Also, when etching solutions that contain hydrofluoric acid in the presence of insufficient nitric acid are used to reveal cracks, they may cause cracks to form if sufficiently high tensile stresses are present initially in the surface.

Smearing is sometimes noticed on ground titanium surfaces. Wheel loading is the primary cause although setup rigidity, wheel speed, and wheel characteristics all contribute.

Grinding difficulties can be minimized by employing the proper type wheels at low wheel speeds and feeds, and by flooding the grinding area with inhibitor or purging types of cutting fluids. Grinding temperatures must be kept low to keep stresses low.

If a choice of finish-machining methods exists, serious considerations should be given to turning, boring, or milling operations rather than grinding. These operations require less time than does grinding and give excellent surface finishes.

Grinding Requirements

Titanium and titanium alloys have similar grinding characteristics except that the former may give a little better wheel life. In both cases, there is a very limited operating range; hence, care must be taken to establish rather precise grinding conditions.

Equipment and Setup

The following recommendations are suggested in order to provide the good grinding conditions needed for titanium:

- High-quality grinders with variable-speed spindles
- Rigid setup of work and wheel
- Rigid mechanical holding fixtures
- Arbors for external grinding
- Oxidized machine centers to prevent galling of small parts
- Backing whenever necessary to overcome deflection of the work.

Selection of Grinding Wheels

Wheel grades should be chosen using the following suggestions as guides:

The largest practical diameter and width of wheel should be used

Grits should possess the characteristics of progressive intergranular chipping as flat spots developed by attrition

The abrasive grain should be of optimum size; smaller sizes allow whole grains to leave the wheel prematurely, resulting in higher wheel wear

Use the hardest wheel that will not cause burning or smearing

Vitrified materials are best in that they are more porous, permit better swarf clearance, and result in grinding at lower temperatures.

Table 11 contains data on the above information and can be used when ordering grinding wheels.

Grinding Wheels Used

Silicon carbide wheels seem to be preferred for producing the best surface finish. On the other hand, aluminum oxide may give lowest residual stresses in the workpiece because they are used at lower speeds.

Downfeed Requirements

In contrast to other metal-cutting methods for titanium, light feeds are required for all abrasive-wheel operations to produce parts with low residual stresses. Downfeeds of 0.0005 to 0.0010 ip are not unusual.

Grinding-Speed Requirements

Wheel speeds of 4000 sfpm are used with silicon carbide wheels and sulfochlorinated oils to produce a good combination of surface finish and dimensional tolerance with relatively low residual stresses.

Lowest residual stresses in a ground titanium surface are produced at low wheel speeds (180 sfpm) using aluminum oxide grinding wheels and rust-inhibitor-type cutting fluids.

Grinding Fluids

The selection of a grinding fluid is very important since the application involves not only cooling but also inhibiting the surface action between titanium and the abrasive wheel. Titanium and its alloys should never be ground dry. Dry grinding results in excessive residual stresses in the ground part in addition to the fire hazard that is present from dry titanium metal dust.

Water alone is not suitable, and ordinary soluble oils do not produce good grinding ratios, although they do reduce the fire hazard of grinding. (See Table 12 for suitable grinding fluids.)

Fluids should be filtered to remove grit and prevent "fish tail" marks on finished surfaces. Fluids should be changed more often than is customary when grinding steel.

TABLE 11. CHART OF MARKINGS ON GRINDING WHEELS

Abrasive Symbols ^(a)		Grit Size				Grain Combination	Wheel Grade			Structure			Bond Types	Manufacturer's Symbols	
Silicon Carbide	Aluminum Oxide	Coarse	Med.	Fine	Very Fine		Soft	Med.	Hard	Dense	Med.	Open			
5C	A	10				1	A			0					
6C	2A	12	36	90	240	2	B			1		9	V=	Modification of bond ^(b) See manufacturer's brochures	
CA	97A	14	46	100	280	3	C			2	6	10	R=		
C2A	4A	16	54	120	320	4	D	I		3	7	11	B=		
C4A	9A	20	60	150	400	5	E	J		4	8	12	E=		
7C		24	70	180	500	6	F	K				13	M=		
		30	80	220	600	7	G	L	Q			14	S=		
							H	M	R			15			
								N	S			16			
								O	T						
								P	U						
									V						
									W						
									X						
									Y						
									Z						

A typical marking sequence: 2A 60 1 - K 6 VL

Description of Various Grades of Silicon Carbide and Aluminum Oxide Abrasives^(a)

C - Silicon Carbide

- 5C - Green Silicon Carbide
- 6C - Black Silicon Carbide
- CA } Mixed Aluminum Oxide and
- C2A } Silicon Carbide
- C4A } Silicon Carbide
- 7C - Mixed Silicon Carbide

A - Aluminum Oxide

- A - Tough Aluminum Oxide
- 2A - Semifriable
- 97A } Friable
- 4A } Friable
- 9A - Very Friable (White)

(a) Cincinnati Milling Machine Company nomenclature. Consult other manufacturers for competitive designations.
 (b) Some manufacturers also add a number designating whether the wheel grade is either exact, 1/3 softer, or 1/3 harder than the better grade indicated (K in the example shown).

TABLE 12. PRECISION GRINDING OF TITANIUM AND ITS ALLOYS

Abrasive Material,(a)	Silicon Carbide		Aluminum Oxide		
Abrasive Types:	Regular, green		Special Friable, white		
Grit Size:	Medium (60-80)		Medium (60-80)		
Wheel Grade (Hardness):	Medium (J-K-L-M)		Medium (K-L-M)		
Structure:	Medium (8)		Medium (8)		
Bond:(b)	Vitrified (V)		Vitrified (V)		
Operation:(c)	Roughing	Finishing	Roughing	Finishing	
Down Feed, ipp:	0.001	0.0005 ^(d)	0.001	0.0005	0.0005 ^(e)
Cross Feed, inch:	0.062, ^(f) 0.050	0.005 ^(f) 0.025	0.05	0.10	0.05
Table, ipm	300-500	300-500	300-500	300-500	
Wheel, sfpm:	2500-4000	2500-4000	1800-2000	1800-2000	
Grinding Fluids:	Highly chlorinated oils or sulfochlorinated oils (do not dilute); possible fire hazard; hence flood the work		Rust-inhibitor types ^(g) present no fire hazard; oils used for silicon carbide wheels also have been used with very little fire hazard, since the low speeds involved generate very little sparking and oil mist		

(a) Equipment considerations are primary in abrasive selection. If only conventional speeds are available, then generally aluminum oxide is not recommended; if low speeds are available, then aluminum oxide is superior.

(b) Particular modification of vitrified bond does not seem to matter with titanium.

(c) Type wheels which have been used include 37C80-L8V and 32A60-L8VBE.

(d) For surface finishes better than 25 microinches rms, the down-feed should be less than 0.0002 ipm on the last pass.

(e) The last 0.003 inch should be removed in steps not to exceed 0.0005 ipm. The final two passes should be at zero depth.

(f) Recommended for B-120VCA using green silicon-carbide wheels.

(g) 10:1 and 20:1 concentration of potassium nitrite have been used. The operating advantages of the latter appear to offset the slight increase of grinding efficiency of the former.

Grinding Techniques and Inspection

Grinding operations should be supervised and controlled very carefully. The recommended procedures should be followed without substitution.

When the grinding procedure used is questionable, quick checks to indicate possible surface cracking can be made by dye and fluorescent penetrants or etching to indicate surface cracking. However, none of these tests will indicate surface damage which does not involve cracking.

When a 1-minute etch with 10 percent HF is used to reveal cracks, care must be taken. Improper etching treatments and etching solutions can cause cracks, since surfaces already may be damaged by residual tensile stresses too small to cause cracks initially.

Each operation should be inspected to insure that it is performed with due regard for the safety of the personnel involved.

Wheels used to grind titanium and its alloys must be dressed more frequently than those used to grind steels because of the tendency of titanium to load the wheel. This causes higher temperatures at the wheel-metal interface, thus tending to produce surface cracks and in some cases to burn the metal.

Some ground parts must be stress relieved by heat treatment prior to final inspection. A common stress relief is to heat the part at 1000 F for 1 hour in a neutral atmosphere to avoid contamination.

Data on speeds and feeds for both silicon carbide and aluminum oxide grinding wheels are shown in Table 12.

Selected References on Precision Grinding

- (1) Clorite, P. A., and Reed, E. C., "Influence of Various Grinding Conditions Upon Residual Stresses in Titanium", American Society of Mechanical Engineers, Trans. ASME, 80 (1) (1958).
- (2) Gunter, J. L., "Determination of Adaptability of Titanium Alloys: Volume III--Processes and Parts Fabrication", Final Report AMC-TR-58-7-574, The Boeing Airplane Company, Seattle, Washington, for the U. S. Air Force under Contract AF 33(600)-33765 (December 1, 1958), AD 156058.
- (3) "Increased Production, Reduced Costs Through a Better Understanding of the Machining Process and Control of Materials, Tools, and Machines", Volume IV, AMC-TR-60-7-532, Curtiss Wright Corporation, Wood-Ridge, New Jersey, for the U. S. Air Force under Contract AF 33(600)-35967 (May, 1960).
- (4) Stewart, I. J., "Machining Characteristics of Aged Titanium Alloy 13V-11Cr-3Al", Paper No. 505D, National Aeronautics Meeting of the Society of Automotive Engineers, New York, New York, April 3-6, 1962.
- (5) Van Voast, J., "Increased Production Reduced Costs Through a Better Understanding of the Machining Process and Control of Materials, Tools, and Machines", Volume IIIa, Curtiss Wright Corporation, Wood-Ridge, New Jersey, for the U. S. Air Force under Contract AF 33(038)-9948 (1954).
- (6) Zlatin, N., Field, M., and Gould, J., "Machining of Refractory Materials", Volume VIII ASD-TR-7-532a, Metcut Research Associates, Inc., Cincinnati, Ohio, for the U. S. Air Force under Contract AF 33(600)-42439, for the period August 1 to October 31, 1962 (November, 1962).

Abrasive Belt Grinding

Introduction

An unusual combination of chemical and physical properties makes titanium more difficult to grind with abrasive belts than most common metals. The surface of titanium may become hardened by reaction with oxygen and nitrogen in air at the high temperatures experienced in grinding. At the same time, the metal tends to weld to the abrasive grains of the belt. The ultimate result is poor belt life--either through an accelerated fracture rate of the abrasive grains or through rapid dulling as the cutting edges become "capped" with titanium. "Capped" grains function as flat bearing areas which slide over the titanium surface, creating additional frictional heat without accomplishing any useful cutting. This characteristic, combined with the low thermal conductivity of titanium, frequently causes burning of the ground surfaces.

Successful grinding of titanium with abrasive belts depends on minimizing the oxygen and nitrogen reaction and also the tendency for welding. Both can be accomplished by lowering the temperature at the grinding point through adequate cooling and by using a grinding fluid which will inhibit the chemical reaction between the abrasive and titanium. Successful grinding also requires controlled "fracture wear" of the abrasive grit in order to supply constant sources of fresh cutting edges during grinding. This can be promoted through the proper choice and combination of abrasive materials, grit size, contact wheel, belt speed, and work feed.

Titanium sheet can be belt ground to close dimensional tolerances. Belt grinders have produced flat surfaces with only 0.004-inch maximum deviation over areas up to 36 by 36 inches. The cost of grinding titanium is estimated to be 6 to 10 times that for stainless steel.

General Grinding Recommendations

Equipment and Setup

The carrier-type machine is usually used in the abrasive belt grinding of sheet. The work is held on a table that oscillates back and forth under the grinding belt. A Billy-roll directly under the contact roll maintains the pressure between the work and the belt.

Machine rigidity is important for achieving close dimensional tolerances.

Selection of Abrasive Belts and Contact Wheels

Abrasive size, belt backing, and type of bond are important factors to consider when choosing an abrasive belt.

Roughing and spotting operations are normally carried out on belts coated with medium- or fine-grain abrasives (40 to 80 grit); Grit 80 is slightly superior to Grits 40 and 60. Extra-fine-grain abrasives (Grits 120 and 220) are used for finish belt-grinding operations.

Three types of belt backings are used for abrasive belt grinding titanium. They include paper-backed, cloth-backed, and fully waterproof cloth-backed belts.

Paper-backed belts, used dry or with a suitable grinding oil, can be used for some flat sheet work. Cloth-backed belts are used when a more rugged backing is needed. Fully waterproof cloth-backed belts are necessary when water-base grinding fluids are used.

All belts are usually manufactured to close tolerances on thickness to permit grinding to precise dimensions.

Synthetic resin bonds provide maximum durability for belts used on titanium. They are available on either a waterproof or nonwaterproof backing.

Abrasive Belt Materials

Coatings of silicon carbide give the best results under normal feeds. These belts must possess a dense texture (closed coat). Aluminum oxide abrasive belts are usually recommended when very heavy feeds are used.

Proper choice of contact wheels is also important in belt grinding. These wheels support the belt, and hence, govern the action and effective penetration of the abrasive grains during the grinding operation. This action has been termed "aggressiveness"--or the ability of the wheel to make the belt cut.

There are two types of contact wheels in use; plain faced and serrated. A plain-faced wheel puts all the abrasive wear on one plane and produces a flat ground surface. A serrated contact wheel has a series of lands and grooves angled across the wheel. This arrangement gives the unique effect of "sharpening" the mineral grains as they undulate over the face of the wheel. The relationship between the lands and the grooves--and the angle at which they cross the face of the wheel--determines to a great extent the cutting rate of the wheel.

Plain-faced wheels are normally used for titanium when unit pressures are high enough to foster the necessary breakdown of abrasive material for best grinding action. They usually produce a better surface finish than do most serrated wheels. They minimize extreme shelling* or mineral loss problems. They also permit off-hand grinding and polishing of curved and contoured parts.

The contact wheel should be small in diameter and as hard as practicable. This combination provides almost a line contact, and hence, a high unit pressure between the abrasive grits and the work.

Suitable contact-wheel materials for titanium include rubber, plastic, or metal. Rubber is usually recommended because metal contact wheels show little significant increase in stock removal and grinding rate at the price of considerable noise, vibration, poorer surfaces, and higher power consumption.

Rubber contact wheels are available in various degrees of hardness, measured in terms of durometer units. These values may range from 10 (sponge rubber) to about 100 (rock hard). The softest rubber (other than sponge) has a value of 20. The harder the contact wheel, the faster an abrasive belt will cut and the coarser the surface finish becomes. Softer wheels produce better surface finishes. However, even soft wheels become effectively harder as spindle speeds increase, and they present more support to the belt. Softer rubber wheels can be used for blending and for spotting operations to remove isolated defects.

The best contact wheel is one which is firm enough to give restricted contact and good penetration by the grit but resilient enough to eliminate shelling failure of the belt at the highest feasible load.

Feed-Pressure Requirements

The correct feed should allow the necessary "fracture wear" of the grains, proper "shelling" of the belt, and effective grain penetration for an economical rate of cut. Under these conditions, metal particles will not clog the belt, and the continual formation of new cutting points on the grains will permit uniform stock removal.

*Shelling is the tendency for the abrasive grains on the abrasive belt to loosen and flake off.

Feeds should be held constant to give the best dimensional tolerances. When feed pressures are increased, it may be advisable to use a softer contact wheel.

Feed pressures between 80 and 120 psi have been used, depending on the speed.

Grinding-Speed Requirements

Speed is important to the rate of cutting, belt life, and desired surface finish. Low belt speeds reduce temperatures at the grinding point and consequently retard oxidation and welding between the metal and abrasive grains. The tendency toward surface scorching or marring by incandescent chips is also reduced.

The optimum speed to be chosen will depend on the contact wheel, grit size, and work thickness.

A definite correlation exists between optimum grinding pressure and belt speed. Higher speeds require less pressure and vice versa.

Grinding Fluids

Lubrication is a most significant factor in abrasive belt grinding. Dry grinding, except for certain intermittent operations (blending, spotting etc.), is not recommended because of the fire hazard.

A grinding fluid should be used when taking continuous cuts over fairly large areas. It reduces grinding temperatures and quenches the intense sparking that occurs when titanium is ground.

Because of the extremely hot sparks formed by titanium, only those grinding oils possessing high flash points (above 325 F) should be used. They should be applied close to the grinding point for rapid spark quenching.

Chemically active organic lubricants may prove superior in finishing operations, provided the fire hazard can be minimized.

With waterproof belts, water-base fluids containing certain inorganic compounds and rust inhibitors give good results. They reduce the fire hazard of titanium dust. Aqueous-solution lubricants seem to give the best performance in grinding setups where high loads are used (stock-removal operations). The following water-base fluids have been used:

- Sodium nitrite (5 percent solution)
- Potassium nitrite (5 percent solution)
- Sodium phosphate* (up to 12 percent solution)
- Potassium phosphate* (up to 30 percent solution).

Soluble oil emulsions in water are normally poor grinding fluids for titanium but can be used where the alternative is to grind dry at speeds greater than 1500 fpm.

Grinding fluids can be applied by spraying or by belt-immersion techniques.

*The phosphate solutions are quite caustic and are excellent paint removers. The more concentrated solutions, however, are not much worse than the 5 percent solutions in these respects and are considerably more effective as grinding lubricants.

Grinding Techniques and Inspection

The same inspection procedures recommended for wheel grinding apply also to belt grinding.

Table 13 summarizes the pertinent data required for the abrasive belt grinding of titanium and its alloys.

TABLE 13. ABRASIVE BELT GRINDING OF TITANIUM AND ITS ALLOYS

Belt Characteristics	Grinding Operation		
	Spotting and Roughing	Finishing	
Abrasive Grit Size	40 to 80 (1-1/2 to 1/8)	120 to 220 (3/0 to 6/0)	
Belt Backing	E (paper) X (cloth)	E (paper) X (cloth)	
Coating Texture	Closed ^(a)	Closed ^(a)	
Bond	Resin	Resin	
Grinding Variables	Spotting	Roughing	Finishing ^(b)
Grit Size ^(c)	40 to 80 (1-1/2 to 1/8)	80	120 to 220 (3/0 to 6/0)
Speed, fpm	1000 to 1500	1500 ^(a) to 2200	1500 ^(a) to 2200
Feed, psi	--	120 to 80	120 to 80
Depth of Cut, inch	--	0.002	0.002
Table Speed, fpm	--	10	10
Grinding Fluids	No	Yes	Yes
Type Grinding Fluids:			
For Paper Belts	Heavily sulfurized chlorinated oils (flash point: 325 F or higher).		
For Cloth Belts	A 10 percent nitride amine rust inhibitor - water solution or a 5 percent potassium nitrite solution. ^(e)		
	Fifteen percent solutions of trisodium or potassium phosphate also have been used.		

- (a) Preferred.
- (b) In finishing operations with fine grits, a light pressure is required to prevent shelling. A dull belt (but cutting well) often produces a finer finish than a new, sharp belt of the same grit.
- (c) Fine grits tend to fall by shelling at pressures which coarser grits will easily withstand.
- (d) Feed pressure is inversely proportional to speed.
- (e) When using potassium nitrite, follow safety precautions described previously.

Selected References on Belt Grinding

- (1) Buhler, T. C., "The Machining and Grinding of Titanium Hydrofoils", R-130, The Miami Shipbuilding Corporation, Miami, Florida, for the U. S. Navy, Bureau of Ships under Contract NObS 72245.
- (2) Cadwell, D. E., Weisbecker, H. L., and McDonald, W. J., "Grinding a Titanium Alloy With Coated Abrasives", Paper No. 58-SA-44, American Society of Mechanical Engineers, Semi-Annual Meeting, Detroit, Michigan, June 15-19, 1958 (March 31, 1958).
- (3) Johnson, S. L., "The Performance of Coated Abrasives", Tooling and Production, 23 (10), 87-90 (January, 1958).
- (4) Seward, W. K., "Contact Wheels for Abrasive Belts", American Machinist/Metalworking Manufacturing, 107 (9), 63-65 (April 29, 1963).
- (5) Van Voast, J., "Increased Production Reduced Costs Through a Better Understanding of the Machining Process and Control of Materials, Tools, and Machines", Volume IIIA, Curtiss Wright Corporation, Wood-Ridge, New Jersey, for the U. S. Air Force under Contract AF 33(038)-9948 (1954).

UNCONVENTIONAL MACHINING

Chemical-Milling Operations

Introduction

Chemical milling generally refers to the shaping, machining, fabrication, or blanking of metal parts by controlled chemical dissolution with suitable chemical reagents or etchants. The process is somewhat similar to the etching procedures that have been used for decades by photoengravers, except that the rates and depths of metal removal are usually much greater for chemical milling.

Much of the earlier work was carried out on aluminum parts for the aircraft industry. It was found that chemical milling could save labor, time, and materials, and also provide increased design capability and flexibility in fabricating parts for advanced aircraft and space missiles and vehicles. During the last 3 or 4 years, there has been an increased amount of interest in utilization of chemical milling for the production of parts of titanium, and of high-strength, high-temperature metals and alloys. Some of the technical information on procedures, solutions, and techniques are of a proprietary nature, and have not been disclosed. ***

Chemical milling is particularly useful for removing metal from the surface of formed or complex-shaped parts, from thin sections, and from large areas to shallow depths. The weight saving is especially important in aircraft and space vehicle design. Metal can be removed from an entire part, or else selective metal removal can be achieved by etching the desired areas, while the other areas are protected by a mask from chemical attack. Tapering, step etching, and sizing of sheets or plates can be done readily by chemical milling. The amount of metal removed or depth of etch is determined by the time of immersion in the etching solutions.

Processing Procedures

The chemical-milling processing procedure consists of four general operations or steps, namely: (1) cleaning (or surface preparation), (2) masking, (3) chemical etching or dissolution, and (4) rinsing and stripping, or removal of the mask. The masking and etching operations are probably the most critical for successful chemical-milling work.

Cleaning

Cleaning of titanium alloy surfaces is usually done by conventional methods, such as wiping with a solvent-dipped cloth, vapor degreasing, and alkali

*CHEM-MILL is the registered trademark of North American Aviation, Inc., which has granted Turco Products, Inc., Wilmington, California, the exclusive right to sublicense other firms to use the CHEM-MILL process.

***Chem-Size** refers to a proprietary chemical dissolution process developed by Anadite, Inc., South Gate, California, for improving the tolerances of as-rolled sheet and plate, and of parts after forming.

***Chem-Tol** refers to the proprietary chemical dissolution process developed by the United States Chemical Milling Corporation, Manhattan Beach, California, for production of sheet material and parts to close tolerances.

line cleaning to remove all dirt and grease. Where scale, oxidation products, or other foreign material are firmly attached to the surfaces, acid pickling or abrasive cleaning might be needed to produce a clean surface. Thorough rinsing followed by drying completes the cleaning operation. Failure to properly clean titanium surfaces will cause masking difficulties and uneven attack of the metal by the etchant solution.

Masking

Masking for titanium alloys involves the application of an acid-resistant coating to protect those part areas where no metal removal is desired. The mask is usually applied by either dip, spray, or flow-coating techniques. The particular method employed depends on part size and configuration. Vinyl polymers⁽¹⁾ are frequently used because of their ability to hold up well against the oxidizing acids generally used in the titanium etchant solutions. Multiple coats (three or more) are used to get sufficient mask thickness and good coverage. The mask coating is usually cured by baking at about 250-300 F for about 1 to 2 hours to improve its adhesion, tensile, and chemical-resistance properties.

Other desirable characteristics of a good mask material are: (1) suitable for accurate pattern transfer on contours and complex configurations; it must maintain straight lines in the etched design, regardless of its complexity, (2) good scribing qualities, (3) easy removal after scribing to present clean surfaces for etching, and (4) good stripping after etching to yield clean surfaces for possible subsequent processing.

The patterns on the masked workpiece are usually applied by means of templates, followed by scribing and then manual peeling of the mask from the areas to be etched. Mask patterns can also be applied to metallic workpieces by silk-screen techniques and by use of photosensitive resists. These procedures are generally utilized on jobs where fine detail and shallow cuts are required.

Etching

A good chemical-milling solution should be capable of removing metal at a predetermined and uniform rate, without adversely affecting dimensional tolerances and the mechanical properties of the workpiece. Pitting, uneven attack of the workpiece surface, or production of rough surface finishes, are all detrimental features of an etchant system.

The more commonly used etchants for chemical milling of titanium alloys are aqueous solutions containing: (1) hydrofluoric acid, (2) hydrofluoric acid-nitric acid mixtures, and (3) hydrofluoric acid-chromic acid mixtures. The exact solution compositions used are proprietary. In addition to the main components given above, the solutions usually contain special additives to enhance their etching characteristics. The presence of dissolved titanium in etchant solutions also helps performance.

Etchant solutions are usually circulated over workpiece surface in order to promote uniform dissolution. Parts also are periodically moved, turned, or rotated to achieve uniform metal removal over the entire surface. Careful solution-composition control and temperature control must be maintained in order

to obtain uniform and predictable rates of metal removal.

Typical production tolerances for chemical milling are ± 0.002 inch.⁽²⁾ To this must be added the actual raw-stock tolerance prior to chemical milling. The following figures can be used as a guide to depth-of-cut limitations for chemical milling.⁽²⁾

Sheet and plate	0.500-inch maximum depth/surface
Extrusion	0.150-inch maximum depth/surface
Forging	0.250-inch maximum depth/surface.

Because chemical etching proceeds sideways at about the same rate as down, the minimum widths that can be machined are about three times the etch depths.

Etching rates for titanium alloys range from about 0.5 to 5.0 mils/min. Typical industrial production rates are about 1.0 to 1.5 mils/min. A comparison of the performance characteristics of etching systems for milling titanium, aluminum, and steel alloys is given in Table 14.⁽³⁾ Typical surface finishes currently being produced on titanium alloys by chemical milling range from about 15 to 50-rms microinches.

TABLE 14. COMPARISON OF DATA AND CHARACTERISTICS OF SYSTEMS FOR CHEMICAL MILLING TITANIUM, ALUMINUM, AND STEEL ALLOYS^(a)

Item	Titanium Alloys	Steels	Aluminum Alloys
Principal Reactants	Hydrofluoric acid	Hydrochloric acid-nitric acid	Sodium hydroxide
Etch Rate, mils/min	0.6 to 1.2	0.6 to 1.2	0.8 to 1.2
Optimum Etch Depth, inch	0.125	0.125	0.125
Etchant Temperature, F	115 \pm 5	145 \pm 5	195 \pm 5
Exothermic Heat, Btu/sq ft/ml	160	130	95
Average Surface Finish, rms microinches	40 to 100	60 to 120	80-120

(a) Data are from Sanz and Shepherd.⁽³⁾

Rinsing and Stripping

After the parts are completely etched, they are thoroughly rinsed with water. The mask is then either stripped by hand or immersed in a solvent tank to soften the mask and facilitate its removal.

Effects on Mechanical Properties

The general feeling is that chemical milling (providing good uniform metal dissolution is achieved; i.e., no intergranular attack, selective etching, or pitting) does not adversely affect the mechanical properties of metals. Published data on those effects are rather scarce and more such data are needed.

Published results from tensile, compressive, and shear tests showed that chemical milling had no significant effect on these mechanical properties for the Ti-6Al-4V alloy.⁽³⁾ Chemical milling also had no significant effect on the tensile properties of 5Al-2.5Sn titanium alloys.⁽³⁾

Hiner⁽⁴⁾ showed that chemical milling did not affect the tensile properties of heat-treated Ti-7Al-4Mo alloys. See Table 15.

TABLE 15. TENSILE PROPERTIES OF CHEMICALLY MILLED Ti-7Al-4Mo ALLOYS^(a,b)

Amount Removed From Diameter, inch	Yield Strength, psi	Ultimate Tensile Strength, psi	Reduction in Area, percent	Elongation, percent in 4 D
Controls	182,000	192,750	30.0	10
0.005	180,750	191,000	31.9	10
0.014	181,500	191,500	34.9	10
0.040	180,500	190,500	31.9	10

(a) Data are from Hiner.⁽⁴⁾

(b) Longitudinal blanks were cut from Ti-7Al-4Mo forged stock and heat treated to 190,000-psi UTS. The blanks were then machined into standard 1/4-inch-diameter tensile specimens. Allowance was made for removal of various amounts of material by chemical milling to permit uniform specimens at time of testing.

A Ryan Aeronautical Company report⁽⁵⁾ gives results of fatigue tests on 6Al-4V and A-110AT (5Al-2.5Sn) titanium alloys. Chemically milled specimens, on the average, showed slightly better fatigue life than the as-received material. On the other hand, Sanz and Shepherd⁽³⁾ cite fatigue test (reversed-cantilever bending) results on 5Al-2.5Sn alloy (A-110AT) sheet indicating that chemical milling increased the hydrogen content of this alloy, and reduced the fatigue strength slightly. Subsequent vacuum annealing of these parts reduced the hydrogen to a low level and increased fatigue strength significantly.

Hydrogen Pickup During Chemical Milling

Titanium alloys are susceptible to hydrogen pickup during chemical milling. The more important factors governing the amount of hydrogen absorbed are: composition and metallurgical structure of the titanium alloy, etchant composition, etchant temperature, and etching time. The amount of hydrogen absorption is related to the amount of beta phase present in the alloy. Results of various studies on hydrogen pickup are discussed below.

The susceptibility of various titanium alloys to hydrogen embrittlement during chemical milling in an HF-H₂O-chromic acid bath was investigated by Jones.⁽⁶⁾ Bath composition was as follows:

Hydrofluoric acid (HF)	23 percent by volume
Water (H ₂ O)	77 percent by volume
Chromic acid	125 grams/liter

Bath temperature was 140 F, and etch rate was 1.0 mil/min. Of the three titanium alloys studied, the beta alloy, Ti-13V-11Cr-3Al, was most severely embrittled. The alpha-beta alloy, Ti-6Al-4V, showed some minor embrittlement, whereas the alpha alloy, Ti-5Al-2.5Sn, was not embrittled. Elevated-temperature vacuum treatments were necessary to restore ductility to the Ti-13V-11Cr-3Al alloy. Because of the minor embrittlement, as shown by bend ductility, no embrittlement-relief treatments were evaluated or deemed necessary for the chemically milled Ti-6Al-4V alloy.

Guerin, Slomiak, and Schneider⁽⁷⁾ reported that considerable hydrogen pickup was observed in experimental Ti-8Al-1Mo-1V parts, chemical milled at an etching rate of 1 mil/side/min at a temperature of 180 F. The solution contained hydrofluoric acid, chromic acid, titanium powder, and dodecyl sulfonic acid. The hydrogen contents before and after are tabulated below:

Material	Hydrogen Content, ppm
As-Received Sheet	40
Chemically Milled From 0.040 to 0.030-Inch Thickness	360
Chemically Milled From 0.040 to 0.010-Inch Thickness	635

The authors indicated that MIL specifications for Ti-8-1-1 alloy allow a maximum 150 ppm, so they would automatically reject these sheets. The large hydrogen pickup was attributed to operation at the high 180 F temperature. However, low etching rates of 0.1 to 0.2 mil/side/min were obtained when operating at 115 F. Further studies to cope with the hydrogen pickup problem were in progress at the time the report was written.

Boyd⁽⁸⁾ has reported the findings of various studies on hydrogen embrittlement of titanium alloys chemically milled in hydrofluoric acid-nitric acid solutions. The hydrogen pickup was closely related to the HNO₃-HF ratio in the bath. One study showed that by maintaining the HNO₃ concentration above 20 percent with 2 percent HF present, the hydrogen pickup could be held to less than 50 ppm for many of the commonly used titanium alloys. However, other investigators reported contrary or different results.

The CHEM-MILL Design Manual⁽²⁾ reports that hydrogen embrittlement is not a serious problem when chemically milling the Ti-8Mn alloy, so long as the initial content is kept below 80 ppm and the part is milled from one side only to a depth not to exceed one-half of the original thickness. It also indicates that with the exception of the all-beta alloy, Ti-13V-11Cr-3Al, none of the other alloys of titanium pick up enough hydrogen during chemical milling to be a problem.

Stearns⁽⁹⁾ states that with the exception of such beta alloys as Ti-13V-11Cr-3Al, a properly controlled titanium etchant has no adverse effects upon the physical properties of the alloy being milled. Surface finishes are consistently good, falling in the 30- to 40-rms-microinches range.

The work discussed above indicates that hydrogen pickup can be a problem in the chemical milling of certain titanium alloys (especially all-beta alloys) under certain operating conditions. Additional research or development work is needed to:

(1) define and understand the hydrogen pickup problem, (2) minimize hydrogen pickup by development of better etchant solutions and operating conditions, and (3) develop suitable baking or vacuum outgassing procedures for embrittlement relief.

Selected References on Chemical-Milling Operations

- (1) Deutsch, H. M. "Maskants for Chemical Milling", *Materials in Design Engineering*, 128-130, 241 (May, 1961).
- (2) "The CHEM-MILL Design Manual", the Chem-Mill and Coatings Division, Turco Products, Inc., Wilmington, California, 21 pp (February, 1961).
- (3) Sanz, M. C., and Shepherd, C. C., "Chem-Mill Process High-Temperature Alloys", SAE Aircraft Production Forum, Metal Removal--High-Temperature Materials Panel, Los Angeles, California (1958).
- (4) Hiner, J. M., "The Effect of Chemical Milling on Tensile Ductility of Heat Treated 7Al-4Mo Titanium Alloy", Report No. A-433, Menasco Manufacturing Co., Burbank, California (October 26, 1961).
- (5) Adams, D. S., and Cattrell, W. M., "Development of Manufacturing Techniques and Processes for Titanium Alloys", Report No. G-17-93, Ryan Aeronautical Company, San Diego, California (April 24, 1957).
- (6) Jones, R. L., "The Susceptibility of Materials to Hydrogen Embrittlement From Chemical Milling Operations", Report No. MRG-219, General Dynamic Corporation, Astronautics Division, San Diego, California (March 16, 1961).
- (7) Guerin, R. L., Slomiak, S., and Schneider, S., "8-1-1 Titanium Alloy--Machining--Assembly--Fastening", *Materials and Manufacturing Techniques for Supersonic Aircraft*, SAE National Aeronautics and Space Engineering and Space Meeting, Los Angeles, California, October 5-9, 1964.
- (8) Boyd, W. K., "Memorandum on the Chemical Milling of Titanium", Titanium Metallurgical Laboratory, Battelle Memorial Institute, Columbus, Ohio (January 17, 1958).
- (9) Stearns, L. B., "Chemical Milling--Solution to Producibility Problems in Temperature Resistant Air Frame Structures", *ASTME Technical Paper No. 315* (1960).

LIST OF DMIC MEMORANDA ISSUED
DEFENSE METALS INFORMATION CENTER
Battelle Memorial Institute
Columbus, Ohio 43201

Copies of the technical memoranda listed below may be obtained from DMIC at no cost by U. S. Government agencies, U. S. Government contractors, subcontractors, and/or their suppliers. Others may purchase copies of these memoranda from: Clearinghouse for Federal Scientific and Technical Information, U. S. Department of Commerce, Springfield, Virginia 22151. The CFSTI reference numbers (PB or AD prefix numbers) and prices are shown in parentheses. HC refers to Hard Copy price; Mf refers to Microfiche price. Orders to CFSTI should refer to the reference numbers and be prepaid.

- Review of Recent Developments in the Technology of High-Strength Stainless Steels, July 14, 1961 (AD 259943, \$0.50)
- Review of Recent Developments in the Metallurgy of High-Strength Steels, July 21, 1961 (AD 259986, \$0.50)
- The Emittance of Iron, Nickel, Cobalt and Their Alloys, July 25, 1961 (AD 261336, \$2.25)
- Review of Recent Developments on Oxidation-Resistant Coatings for Refractory Metals, July 31, 1961 (AD 261293, \$0.50)
- Fabricating and Machining Practices for the All-Beta Titanium Alloy, August 3, 1961 (AD 262496, \$0.50)
- Review of Recent Developments in the Technology of Nickel-Base and Cobalt-Base Alloys, August 4, 1961 (AD 261292, \$0.50)
- Review of Recent Developments in the Technology of Beryllium, August 18, 1961 (AD 262497, \$0.50)
- Investigation of Delayed-Cracking Phenomenon in Hydrogenated Unalloyed Titanium, August 30, 1961 (AD 263164, \$0.50)
- Review of Recent Developments in Metals Joining, September 1, 1961 (AD 262905, \$0.50)
- A Review of Recent Developments in Titanium and Titanium Alloy Technology, September 15, 1961 (AD 263167, \$0.50)
- Review of Recent Developments in the Technology of Tungsten, September 22, 1961 (AD 263888, \$0.50)
- Review of Recent Developments in the Evaluation of Special Metal Properties, September 27, 1961 (AD 263994, \$0.50)
- Review of Recent Developments in the Technology of Molybdenum and Molybdenum-Base Alloys, October 6, 1961 (AD 264291, \$0.50)
- Review of Recent Developments in the Technology of Columbium and Tantalum, October 10, 1961 (AD 264983, \$0.50)
- Review of Recent Developments in the Technology of High-Strength Stainless Steels, October 13, 1961 (AD 264984, \$0.50)
- Review of Recent Developments in the Metallurgy of High-Strength Steels, October 20, 1961 (AD 265135, \$0.50)
- Titanium in Aerospace Applications, October 24, 1961 (AD 266927, \$0.50)
- Machining of Superalloys and Refractory Metals, October 27, 1961 (AD 268081, \$1.00)
- Review of Recent Developments in the Technology of Nickel-Base and Cobalt-Base Alloys, October 31, 1961 (AD 266004, \$0.50)
- Fabrication of Tungsten for Solid-Propellant Rocket Nozzles, November 2, 1961 (AD 268311, \$0.75)
- Review of Recent Developments on Oxidation-Resistant Coatings for Refractory Metals, November 8, 1961 (AD 266469, \$0.50)
- Review of Recent Developments in the Technology of Beryllium, November 16, 1961 (AD 267079, \$0.50)
- Review of Recent Developments in the Technology of Tungsten, November 24, 1961 (AD 268082, \$0.50)
- Review of Recent Developments in Metals Joining, December 6, 1961 (AD 268312, \$0.50)
- The Emittance of Chromium, Columbium, Molybdenum, Tantalum, and Tungsten, December 10, 1961 (AD 269784, \$1.25)
- Effects of Moderately High Strain Rates on the Tensile Properties of Metals, December 18, 1961 (AD 270167, \$1.00)
- Notes on the Forging of Refractory Metals, December 21, 1961 (AD 271030, \$1.50)
- Review of Recent Developments in Titanium Alloy Technology, December 29, 1961 (AD 269209, \$0.50)
- The Use of Nickel-Base Alloys in the Rotating Parts of Gas Turbines for Aerospace Applications, January 11, 1962 (AD 271174, \$0.75)
- Magnesium-Lithium Alloys - A Review of Current Developments, February 6, 1962 (AD 272683, \$0.75)
- An Evaluation of Materials for Rocket-Motor Cases Based on Minimum-Weight Concepts, March 8, 1962 (AD 273297, \$1.00)
- The Emittance of Ceramics and Graphites, March 28, 1962 (AD 274148, \$2.50)
- Methods of Strengthening the Ultrahigh-Strength Steels, April 2, 1962 (AD 275041, \$1.00)
- Compilation of Tensile Properties of High-Strength Alloys, April 23, 1962 (AD 275263, \$1.25)
- Compatibility of Propellants 113 and 114B2 with Aerospace Structural Materials, April 27, 1962 (AD 275427, \$0.50)
- Electron-Beam Welding of Tungsten, May 21, 1962 (AD 276283, \$0.50)
- Brazing and Bonding of Columbium, Molybdenum, Tantalum, Tungsten and Graphite, June 11, 1962 (AD 278193, \$0.75)
- The Effects of Decarburization on the Properties of Ultrahigh-Strength Steels, June 18, 1962 (AD 278194, \$0.75)
- The Effects of Solute on the Ductile-to-Brittle Transition in Refractory Metals, June 28, 1962 (AD 278652, \$1.75)
- Properties of Mar-Aging Steels, July 2, 1962 (AD 281888, \$1.50)
- A Compilation of the Tensile Properties of Tungsten, September 11, 1962 (AD 283572, \$1.00)
- Summary of Briefings on Refractory Metal Fasteners, October 8, 1962 (AD 287287, \$1.00)
- Nondestructive Testing of Solid-Propellant Rocket Motors, October 24, 1962 (AD 287803, \$0.50)

DMIC supply exhausted; copies may be ordered from CFSTI.

LIST OF DMIC MEMORANDA ISSUED (CONTINUED)

<u>Number</u>	<u>Title</u>
*160	Identification of Microconstituents in Superalloys, November 15, 1962 (AD 289664, \$0.75)
*161	Electron Microscopic Fractography, December 21, 1962 (AD 295029, \$1.00)
162	Report on Meeting to Review Maraging Steel Projects, December 28, 1962 (AD 296040, \$0.75)
163	Reactivity of Metals with Liquid and Gaseous Oxygen, January 15, 1963 (AD 297124, \$0.75)
164	A Discussion of the Fracture Toughness of Several Stainless Steels in Sheet Form, January 31, 1963 (AD 298204, \$3.60)
165	Review of Uses for Depleted Uranium and Nonenergy Uses for Natural Uranium, February 1, 1963 (AD 299705, \$0.75)
166	Literature Survey on the Effect of Sonic and Ultrasonic Vibrations in Controlling Grain Size During Solidification of Steel Ingots and Weldments, May 15, 1963 (AD 410538, \$1.00)
167	Notes on Large-Size Furnaces for Heat Treating Metal Assemblies, May 24, 1963 (A Revision of DMIC Memo 63) (AD 410282, \$0.50)
168	Some Observations on the Arc Melting of Tungsten, May 31, 1963 (AD 409824, \$0.50)
169	Weldability Studies of Three Commercial Columbium-Base Alloys, June 17, 1963 (AD 415203, \$0.75)
170	Creep of Columbium Alloys, June 24, 1963 (AD 424097, \$2.25)
171	A Tabulation of Designations, Properties, and Treatments of Titanium and Titanium Alloys, July 15, 1963 (AD 424412, \$0.50)
172	Production Problems Associated with Coating Refractory Metal Hardware for Aerospace Vehicles, July 26, 1963
173	Reactivity of Titanium with Gaseous N ₂ O ₄ Under Conditions of Tensile Rupture, August 1, 1963 (AD 41955 \$0.50)
174	Some Design Aspects of Fracture in Flat Sheet Specimens and Cylindrical Pressure Vessels, August 9, 1963 (AD 420376, \$0.75)
175	Consideration of Steels with Over 150,000 psi Yield Strength for Deep-Submergence Hulls, August 16, 1963 (AD 420873, \$0.50)
176	Preparation and Properties of Fiber-Reinforced Structural Materials, August 22, 1963 (AD 422242, \$0.75)
177	Designations of Alloys for Aircraft and Missiles, September 4, 1963 (AD 424998, \$1.75)
178	Some Observations on the Distribution of Stress in the Vicinity of a Crack in the Center of a Plate, September 18, 1963 (AD 422463, \$1.00)
179	Short-Time Tensile Properties of the Co-20Cr-15W-10Ni Cobalt-Base Alloy, September 27, 1963 (AD 425922 \$2.75)
180	The Problem of Hydrogen in Steel, October 1, 1963 (AD 425124, \$1.00)
181	Report on the Third Maraging Steel Project Review, October 7, 1963 (AD 425125, \$1.50)
182	The Current Status of the Welding of Maraging Steels, October 16, 1963 (AD 425714, \$1.00)
183	The Current Status and 1970 Potential for Selected Defense Metals, October 31, 1963 (AD 425604, \$1.25)
184	A Review and Comparison of Alloys for Future Solid-Propellant Rocket-Motor Cases, November 15, 1963 (AD 430165, \$1.25)
185	Classification of DMIC Reports and Memoranda by Major Subject, January 15, 1964
186	A Review of Some Electron-Microscopic Fractographic Studies of Aluminum Alloys, February 5, 1964 (AD 434212, \$0.50)
187	Some Observations on the Electron-Microscopic Fractography of Embrittled Steels, February 19, 1964 (AD 602288, \$2.25)
188	A Review of Available Information on the Welding of Thick Titanium Plate in the USSR, March 6, 1964
189	A Review of Dimensional Instability in Metals, March 19, 1964
190	Continued Observations on the Distribution of Stress in the Vicinity of a Crack in the Center of a Plate, April 14, 1964
191	Observations on Delayed Cracking in Welded Structures of Unalloyed Titanium Sheet, April 29, 1964
192	Summary of the Eighth Meeting of the Refractory Composites Working Group, April 20, 1964
193	Mechanical and Physical Properties of Three Superalloys--MAR-M200, MAR-M302, and MAR-M322, May 6, 1964
194	Porosity in Titanium Welds, June 1, 1964
195	The Production of Powder-Metallurgy Tungsten Sheet and Plate, July 20, 1964
196	Report on the Fourth Maraging-Steel Project Review, August 19, 1964
197	Electrodeposited, Electroless, and Anodized Coatings on Beryllium, September 1, 1964
198	Surface Damage in Machined Beryllium, January 4, 1965

Unclassified

Security Classification

DOCUMENT CONTROL DATA - R&D

(Security classification of title, body of abstract and indexing annotation must be entered when the overall report is classified)

ORIGINATING ACTIVITY (Corporate author) Battelle Memorial Institute Defense Metals Information Center 505 King Avenue, Columbus, Ohio 43201	2a. REPORT SECURITY CLASSIFICATION Unclassified
	2b. GROUP —

REPORT TITLE
Machining of Titanium Alloys

DESCRIPTIVE NOTES (Type of report and inclusive dates)
DMIC Memorandum

AUTHOR(S) (Last name, first name, initial)
Olofson, Carl T., Gerds, Arnold F., Boulger, Francis W., and Gurklis, John A.

REPORT DATE February 2, 1965	7a. TOTAL NO. OF PAGES 23	7b. NO. OF REFS 56
---------------------------------	------------------------------	-----------------------

CONTRACT OR GRANT NO. AF 33(615)-1121 PROJECT NO. 8975	9a. ORIGINATOR'S REPORT NUMBER(S) DMIC Memorandum 199
	9b. OTHER REPORT NO(S) (Any other numbers that may be assigned this report)

AVAILABILITY/LIMITATION NOTICES Copies may be obtained from DMIC at no cost by government agencies and by Government contractors, subcontractors, and their suppliers. Others may purchase copies from: Clearinghouse for Federal Scientific and Technical Information, U. S. Department of Commerce, Springfield, Virginia 22151

SUPPLEMENTARY NOTES	12. SPONSORING MILITARY ACTIVITY United States Air Force Research and Technology Division Wright-Patterson Air Force Base, Ohio 45433
---------------------	--

ABSTRACT

This memorandum summarizes current knowledge respecting the machining of titanium alloys. During 1957, the Titanium Metallurgical Laboratory, now the Defense Metals Information Center, published TML Report 80, "Manual on the Machining and Grinding of Titanium and Titanium Alloys". TML 80 summarized the state of the art of machining commercially pure titanium and the titanium alloys available at that time. The present memorandum combines the basic information from this and other TML and DMIC publications with more recent data obtained from government reports and personal interviews. The memorandum deals with the following conventional machining operations: milling, face milling, peripheral milling, turning, boring, drilling, tapping, and grinding. The last section of the memorandum deals with chemical milling operations.

14. KEY WORDS	LINK A		LINK B		LINK
	ROLE	WT	ROLE	WT	ROLE
Machining					
Titanium alloys					
Milling					
Turning					
Boring					
Drilling					
Tapping					
Grinding					
Chemical milling					
Tool materials					
Feeds					
Depth of cut					
Cutting fluids					
Grinding fluids					
Equipment					

INSTRUCTIONS

1. **ORIGINATING ACTIVITY:** Enter the name and address of the contractor, subcontractor, grantee, Department of Defense activity or other organization (*corporate author*) issuing the report.
- 2a. **REPORT SECURITY CLASSIFICATION:** Enter the overall security classification of the report. Indicate whether "Restricted Data" is included. Marking is to be in accordance with appropriate security regulations.
- 2b. **GROUP:** Automatic downgrading is specified in DoD Directive 5200.10 and Armed Forces Industrial Manual. Enter the group number. Also, when applicable, show that optional markings have been used for Group 3 and Group 4 as authorized.
3. **REPORT TITLE:** Enter the complete report title in all capital letters. Titles in all cases should be unclassified. If a meaningful title cannot be selected without classification, show title classification in all capitals in parenthesis immediately following the title.
4. **DESCRIPTIVE NOTES:** If appropriate, enter the type of report, e.g., interim, progress, summary, annual, or final. Give the inclusive dates when a specific reporting period is covered.
5. **AUTHOR(S):** Enter the name(s) of author(s) as shown on or in the report. Enter last name, first name, middle initial. If military, show rank and branch of service. The name of the principal author is an absolute minimum requirement.
6. **REPORT DATE:** Enter the date of the report as day, month, year; or month, year. If more than one date appears on the report, use date of publication.
- 7a. **TOTAL NUMBER OF PAGES:** The total page count should follow normal pagination procedures, i.e., enter the number of pages containing information.
- 7b. **NUMBER OF REFERENCES:** Enter the total number of references cited in the report.
- 8a. **CONTRACT OR GRANT NUMBER:** If appropriate, enter the applicable number of the contract or grant under which the report was written.
- 8b, 8c, & 8d. **PROJECT NUMBER:** Enter the appropriate military department identification, such as project number, subproject number, system numbers, task number, etc.
- 9a. **ORIGINATOR'S REPORT NUMBER(S):** Enter the official report number by which the document will be identified and controlled by the originating activity. This number must be unique to this report.
- 9b. **OTHER REPORT NUMBER(S):** If the report has been assigned any other report numbers (*either by the originator or by the sponsor*), also enter this number(s).
10. **AVAILABILITY/LIMITATION NOTICES:** Enter any limitations on further dissemination of the report, other than those

imposed by security classification, using standard statements such as:

- (1) "Qualified requesters may obtain copies of this report from DDC."
- (2) "Foreign announcement and dissemination of this report by DDC is not authorized."
- (3) "U. S. Government agencies may obtain copies of this report directly from DDC. Other qualified DDC users shall request through _____"
- (4) "U. S. military agencies may obtain copies of this report directly from DDC. Other qualified users shall request through _____"
- (5) "All distribution of this report is controlled. Qualified DDC users shall request through _____"

If the report has been furnished to the Office of Technical Services, Department of Commerce, for sale to the public, indicate this fact and enter the price, if known.

11. **SUPPLEMENTARY NOTES:** Use for additional explanatory notes.
12. **SPONSORING MILITARY ACTIVITY:** Enter the name of the departmental project office or laboratory sponsoring (*pending for*) the research and development. Include address.
13. **ABSTRACT:** Enter an abstract giving a brief and factual summary of the document indicative of the report, even though it may also appear elsewhere in the body of the technical report. If additional space is required, a continuation sheet may be attached.

It is highly desirable that the abstract of classified reports be unclassified. Each paragraph of the abstract shall end with an indication of the military security classification of the information in the paragraph, represented as (TS), (S), (C), or (U).

There is no limitation on the length of the abstract. However, the suggested length is from 150 to 225 words.

14. **KEY WORDS:** Key words are technically meaningful terms or short phrases that characterize a report and may be used as index entries for cataloging the report. Key words must be selected so that no security classification is required. Identifiers, such as equipment model designation, trade name, military project code name, geographic location, may be used as key words but will be followed by an indication of technical content. The assignment of links, rules, and weights is optional.