



US 20060211924A1

(19) **United States**

(12) **Patent Application Publication**
Dalke et al.

(10) **Pub. No.: US 2006/0211924 A1**

(43) **Pub. Date: Sep. 21, 2006**

(54) **MULTIPLE WAVELENGTH SENSOR EMITTERS**

Related U.S. Application Data

(76) Inventors: **David Dalke**, Irvine, CA (US); **Ammar Al-Ali**, Tustin, CA (US); **Mohamed Diab**, Mission Viejo, CA (US); **Marcelo Lamego**, Rancho Santa Margarita, CA (US); **Robert Smith**, Lake Forest, CA (US)

(60) Provisional application No. 60/657,596, filed on Mar. 1, 2005. Provisional application No. 60/657,281, filed on Mar. 1, 2005. Provisional application No. 60/657,268, filed on Mar. 1, 2005. Provisional application No. 60/657,759, filed on Mar. 1, 2005.

Publication Classification

Correspondence Address:
KNOBBE MARTENS OLSON & BEAR LLP
2040 MAIN STREET
FOURTEENTH FLOOR
IRVINE, CA 92614 (US)

(51) **Int. Cl.**
A61B 5/00 (2006.01)
(52) **U.S. Cl.** **600/310; 600/326**

(57) **ABSTRACT**

A physiological sensor has light emitting sources, each activated by addressing at least one row and at least one column of an electrical grid. The light emitting sources are capable of transmitting light of multiple wavelengths and a detector is responsive to the transmitted light after attenuation by body tissue.

(21) Appl. No.: **11/367,013**

(22) Filed: **Mar. 1, 2006**

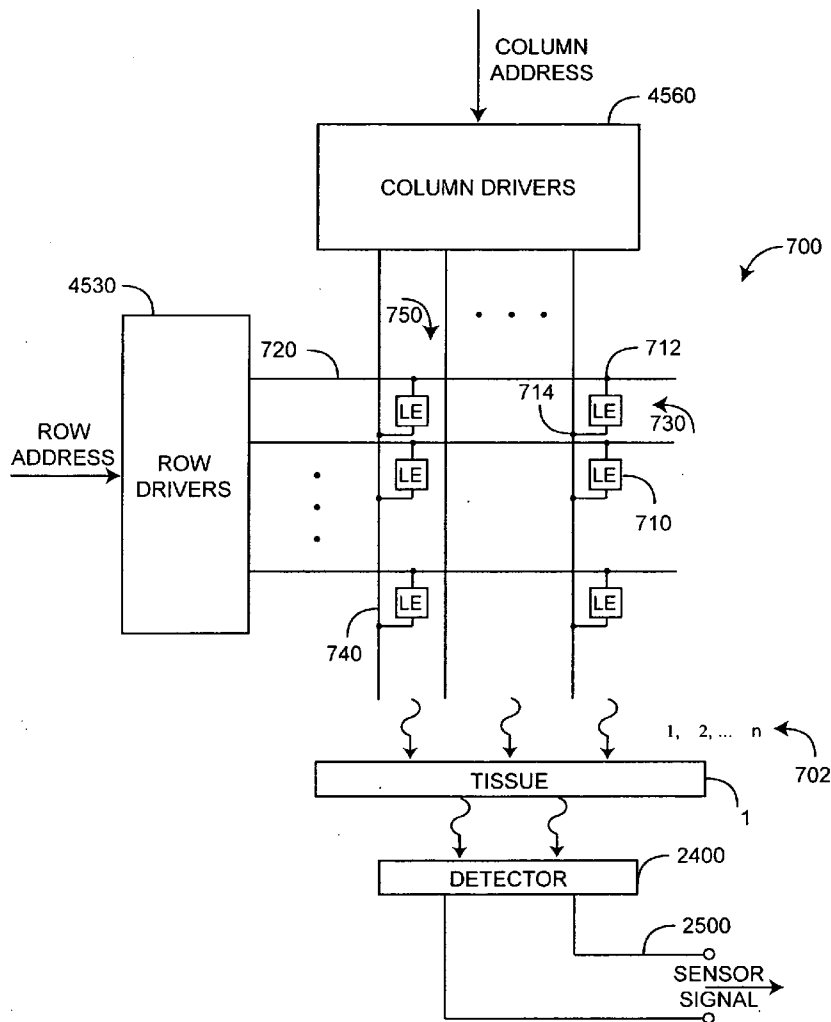

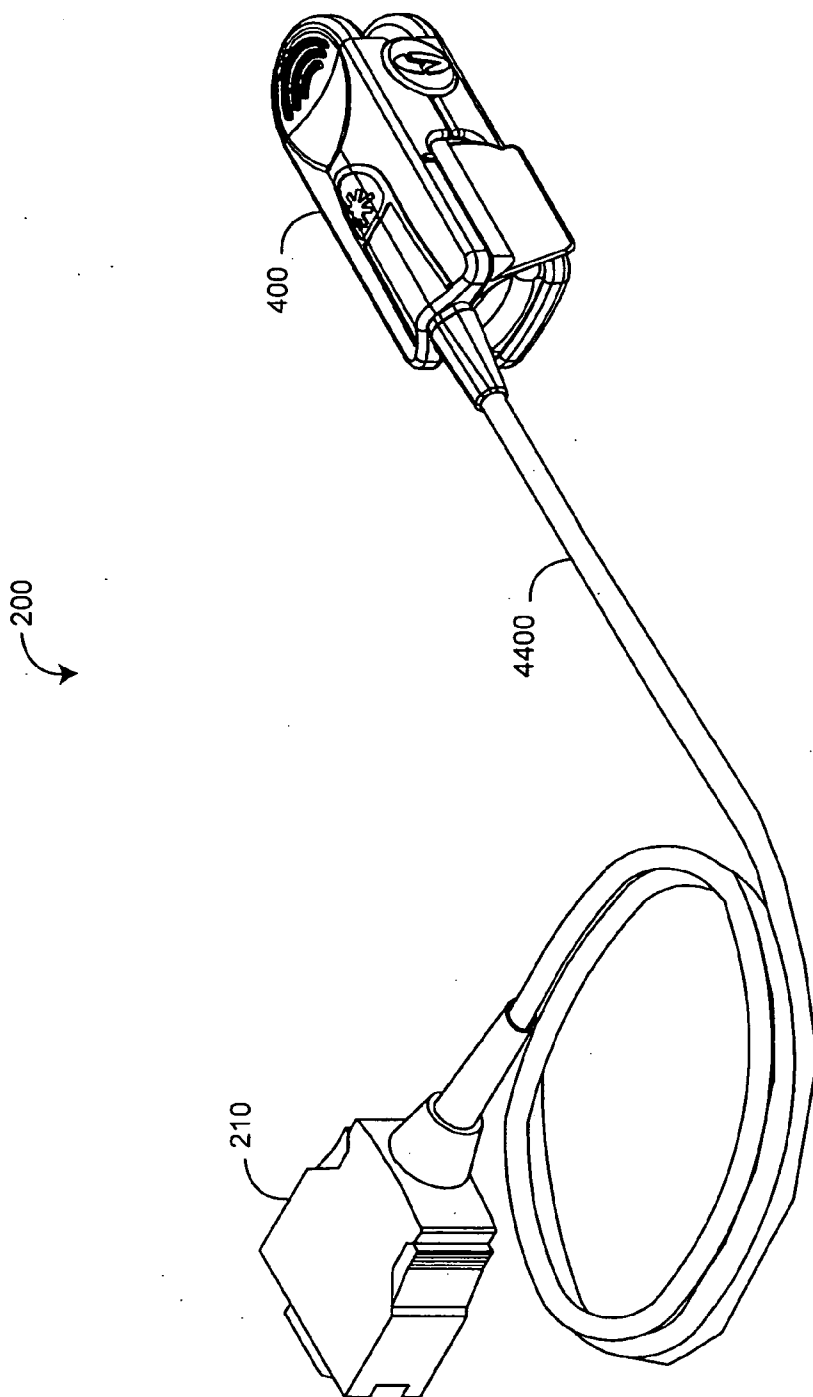

FIG. 2A

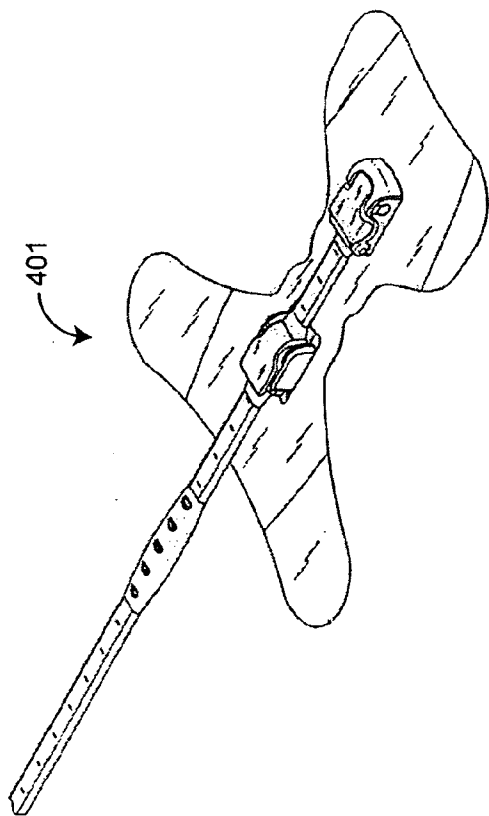

FIG. 2B

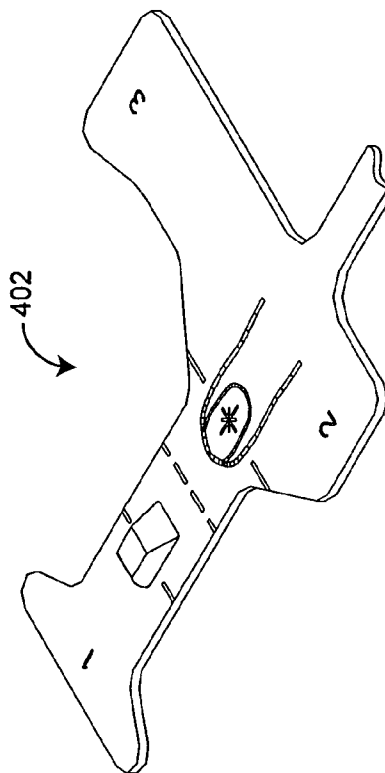

FIG. 2C

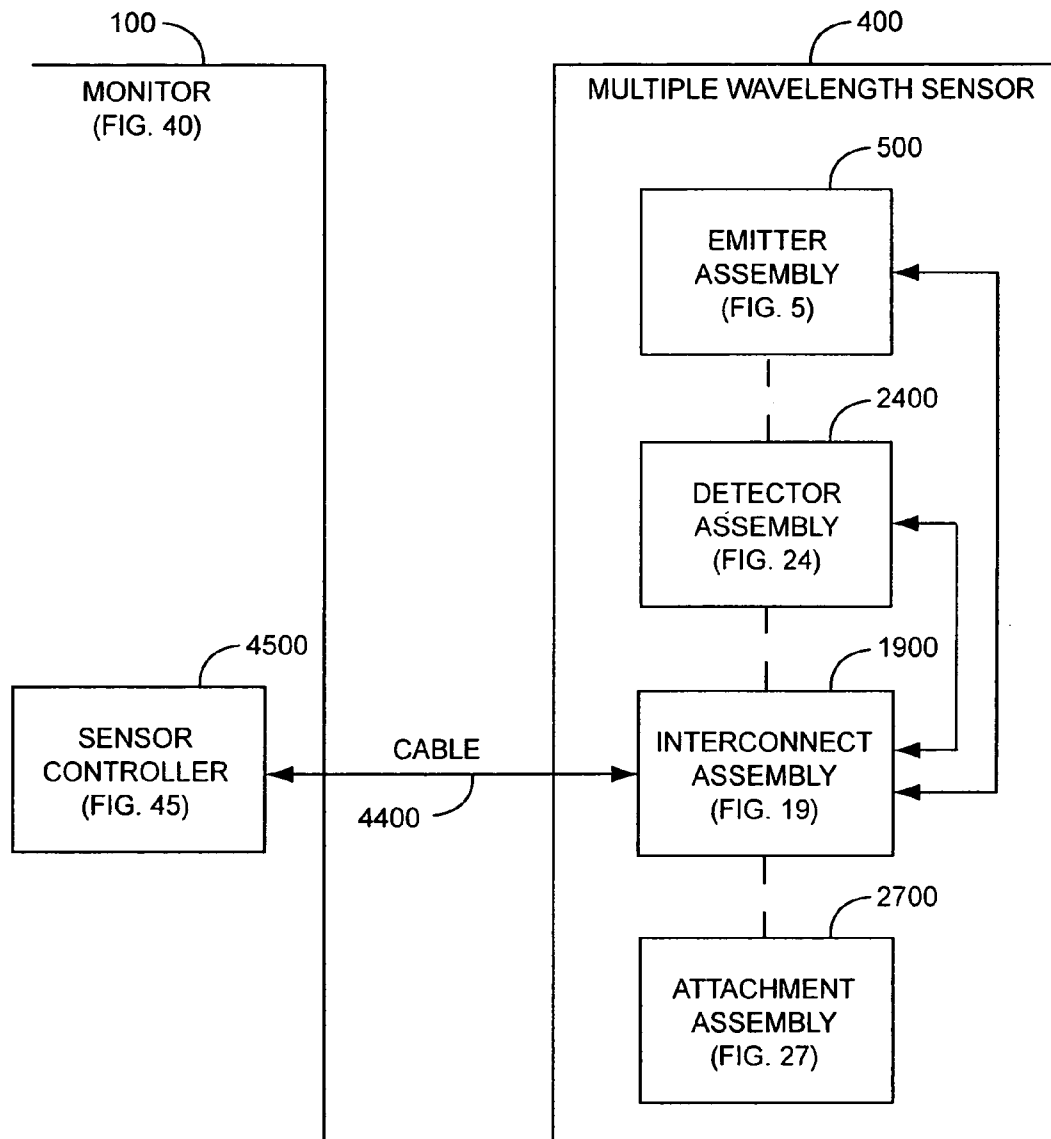

FIG. 3

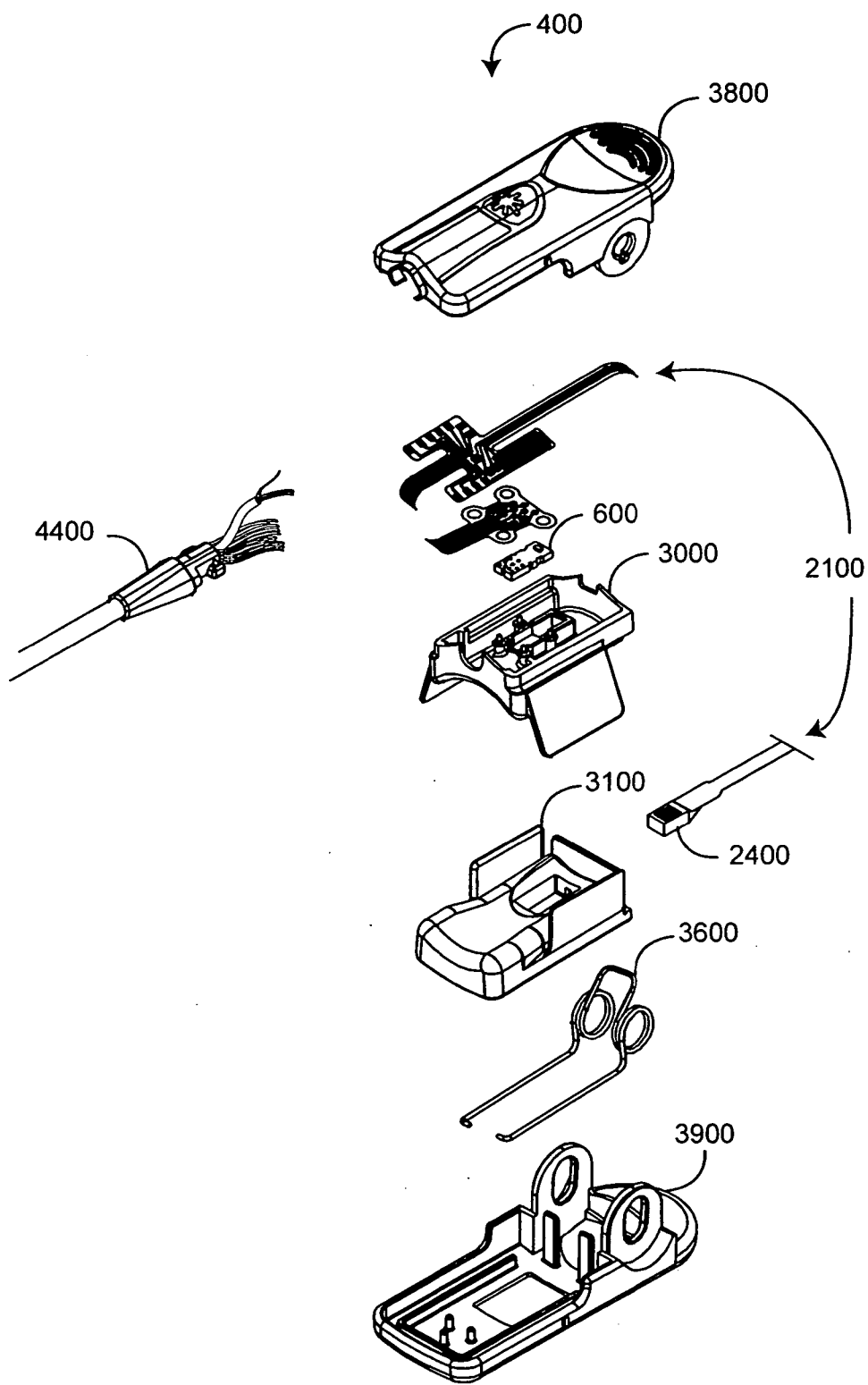

FIG. 4

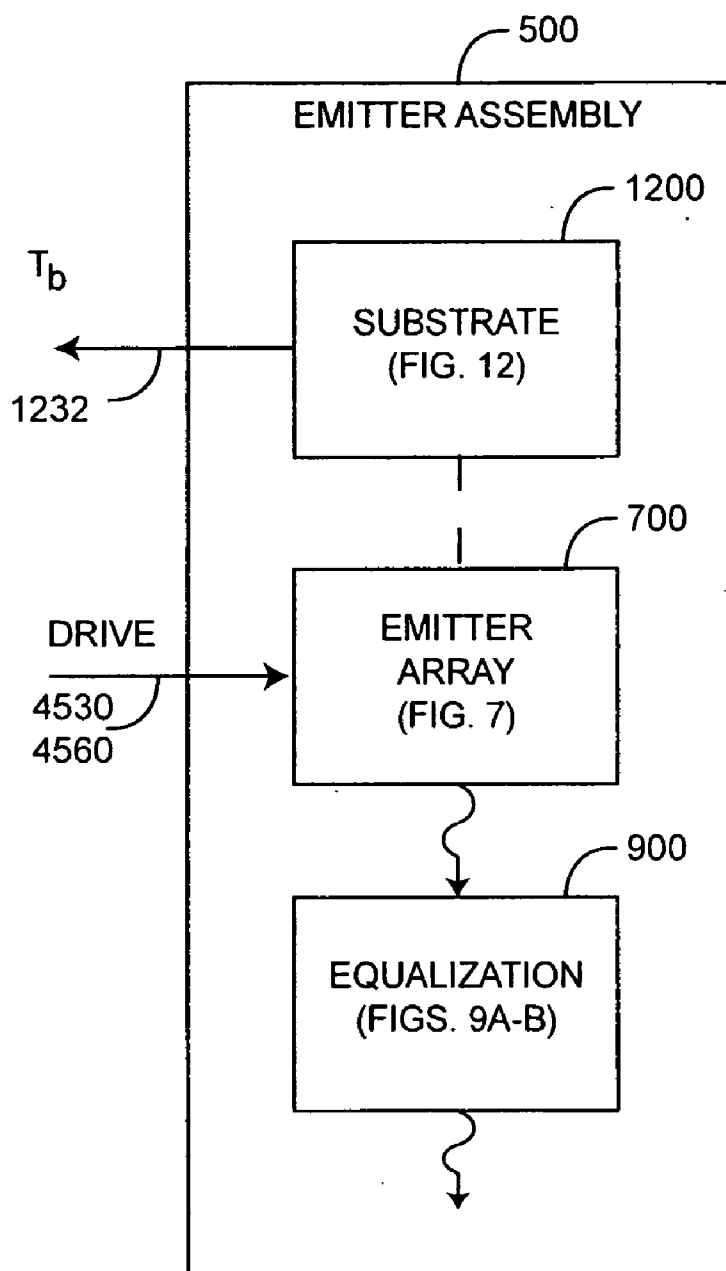

FIG. 5

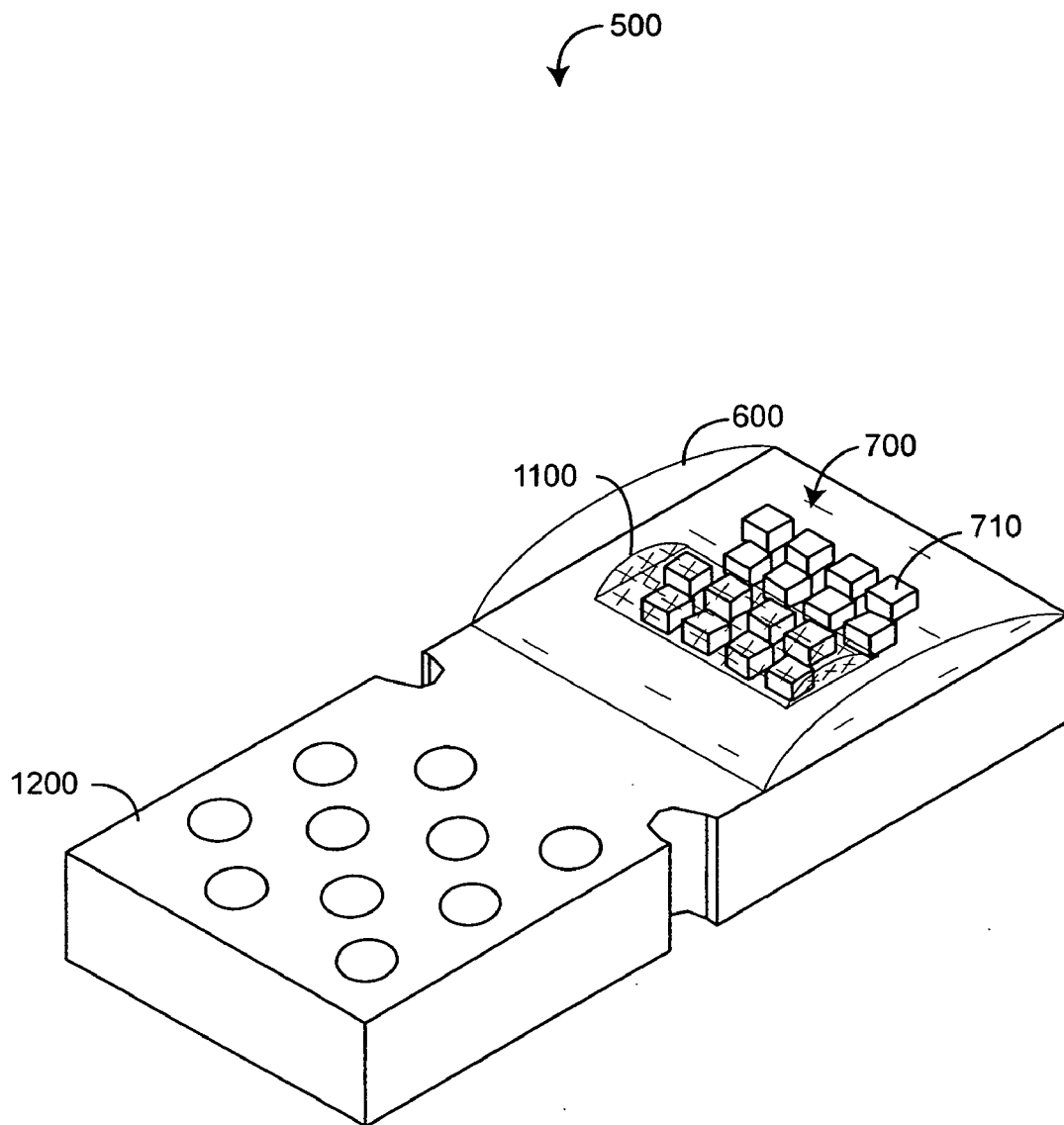

FIG. 6

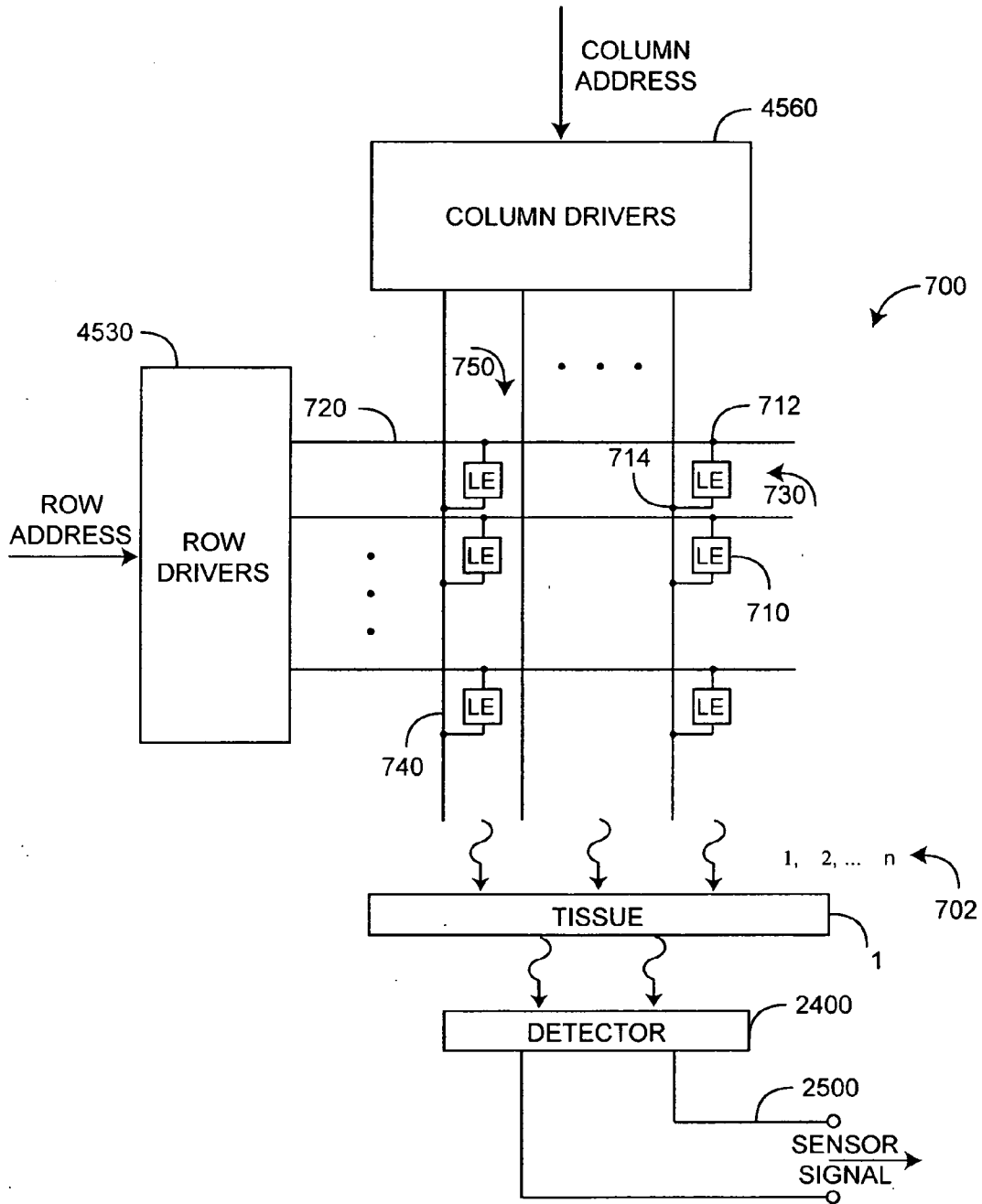

FIG. 7

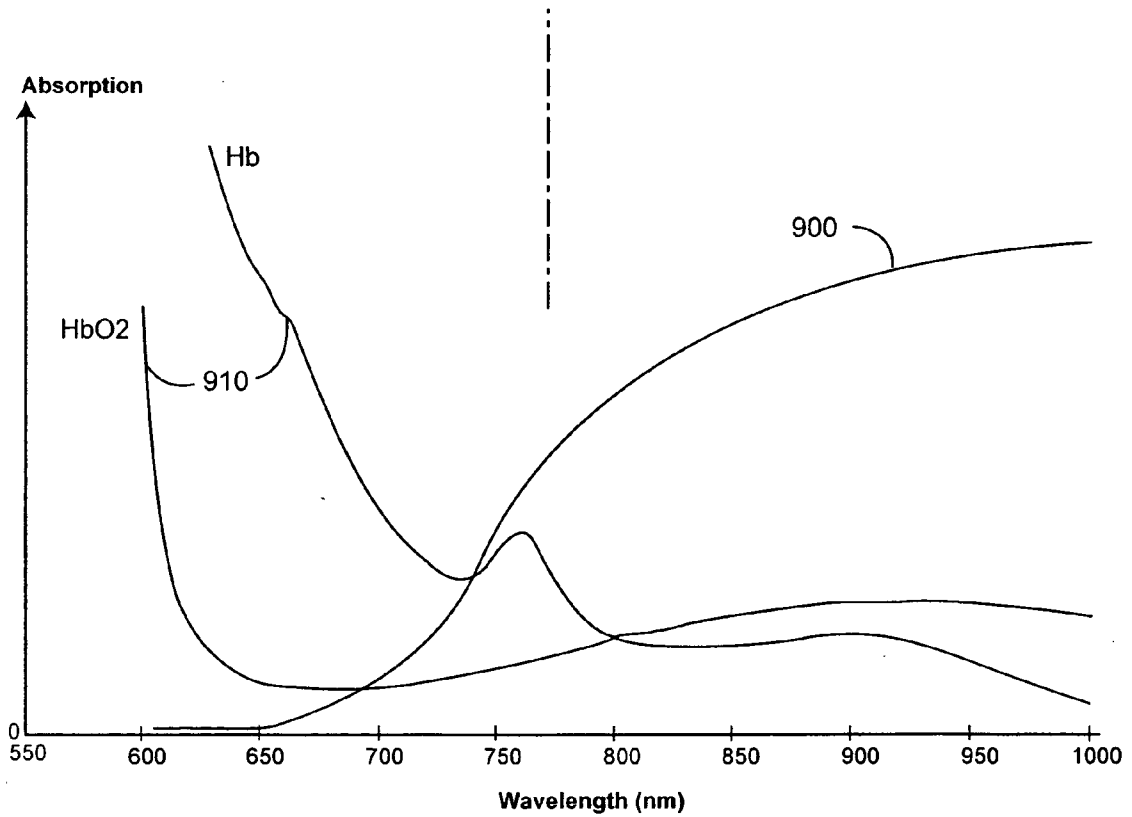
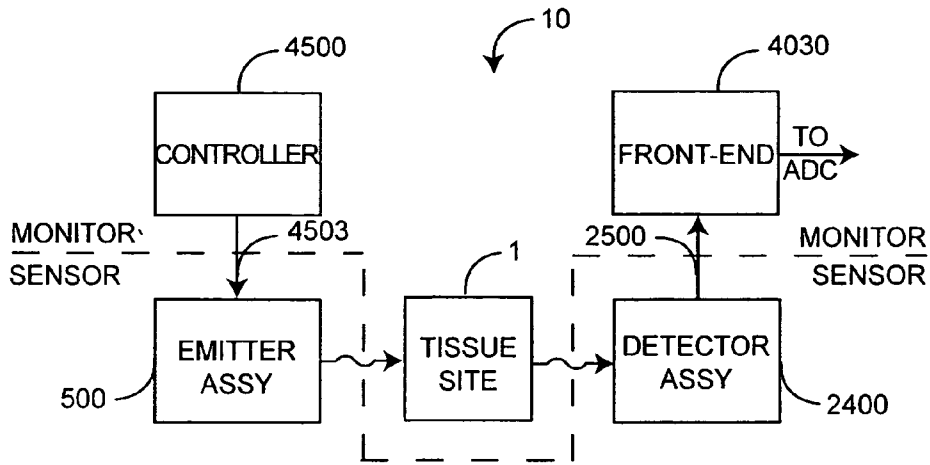

FIG. 9

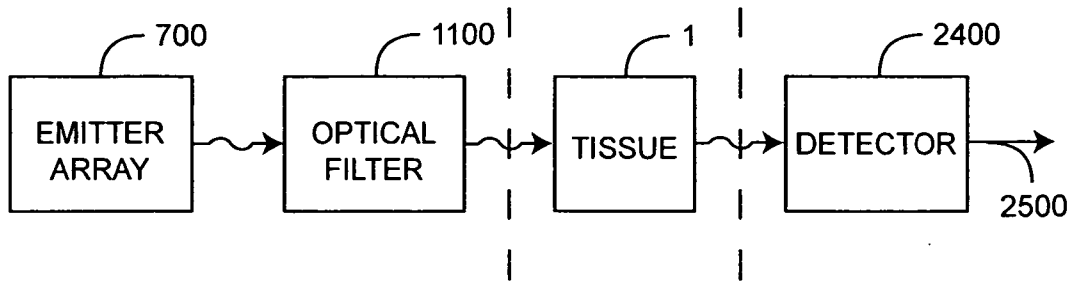

FIG. 10A

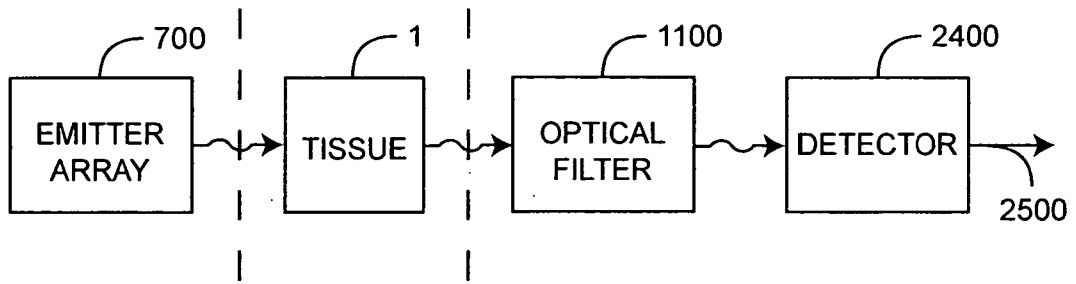

FIG. 10B

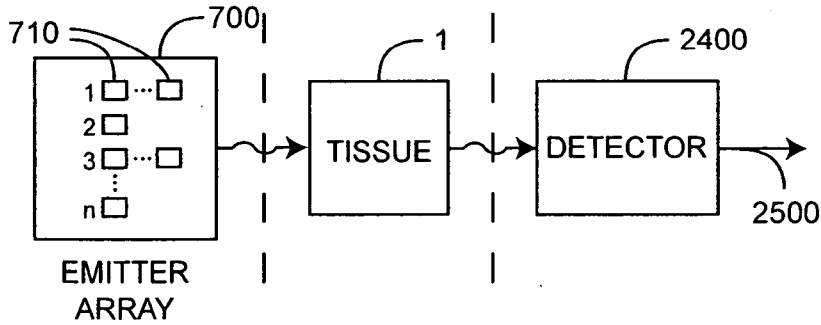

FIG. 10C

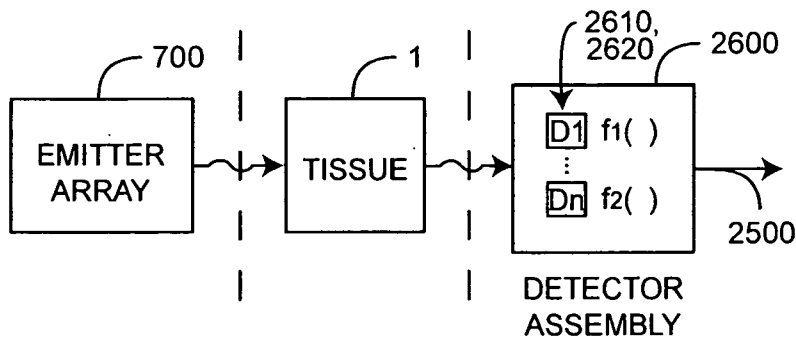

FIG. 10D

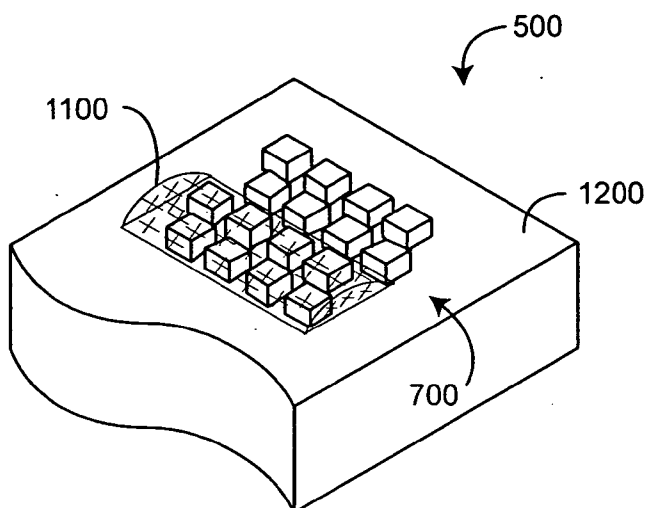

FIG. 11A

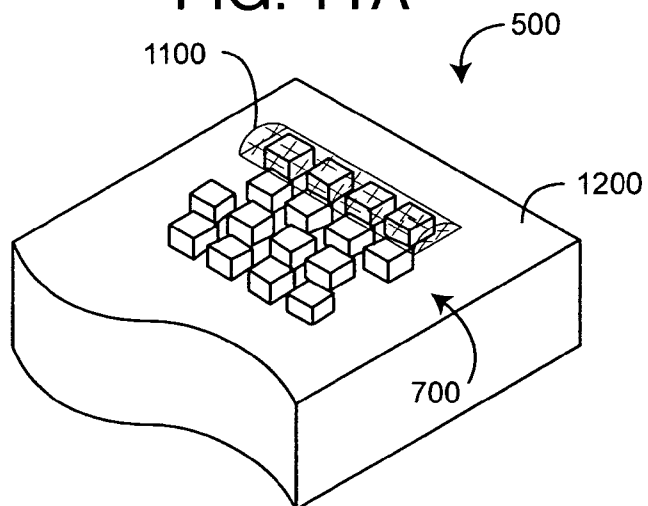

FIG. 11B

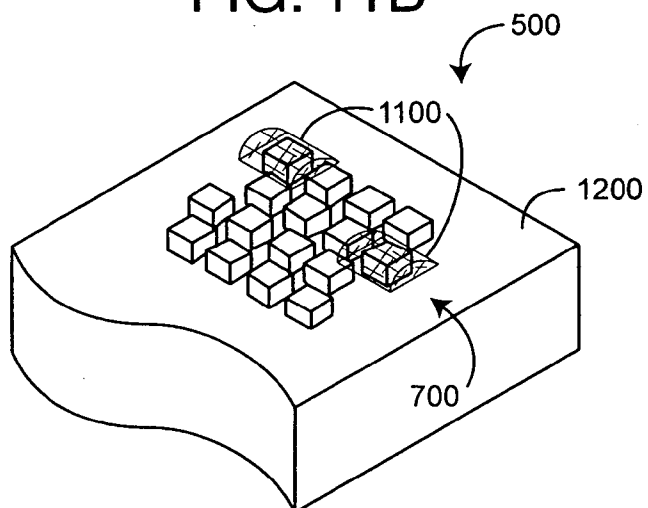

FIG. 11C

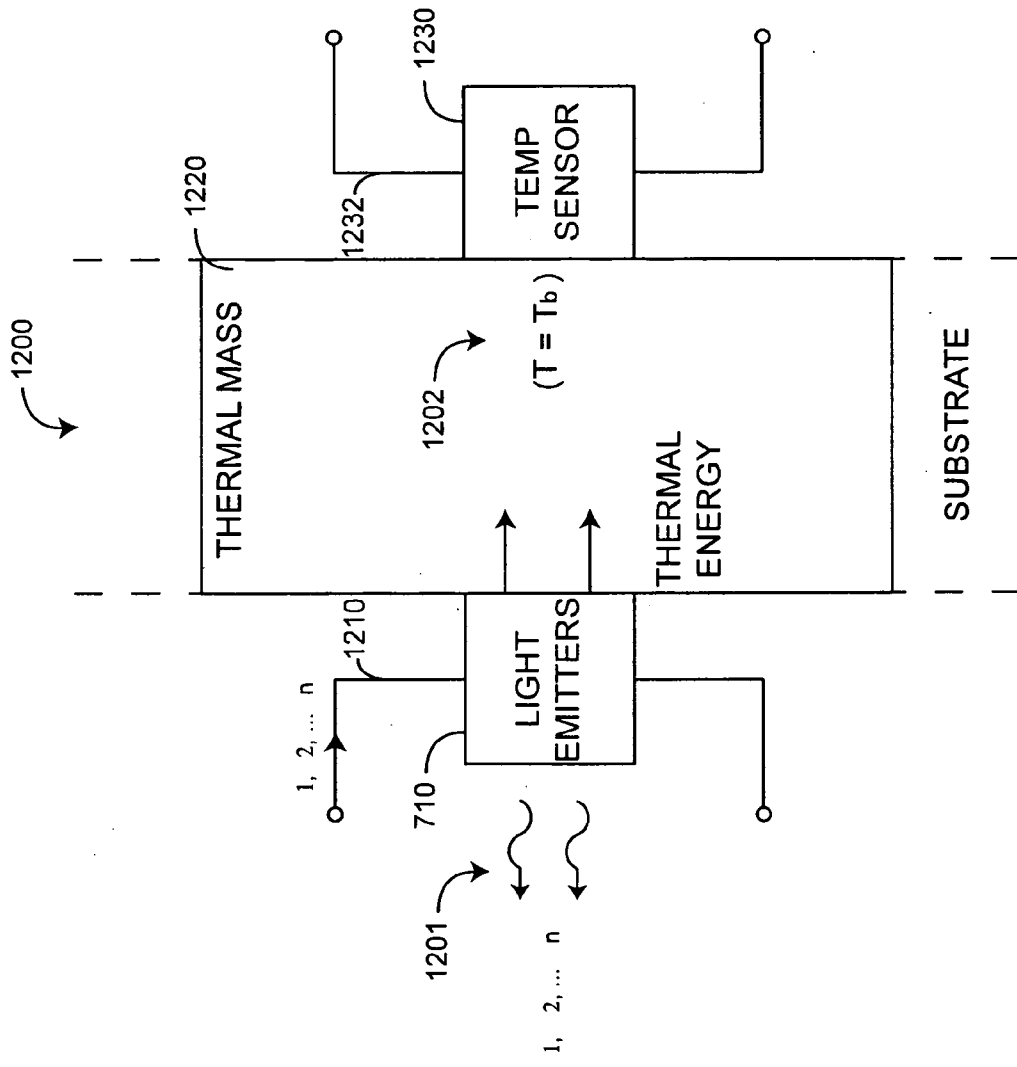

FIG. 12

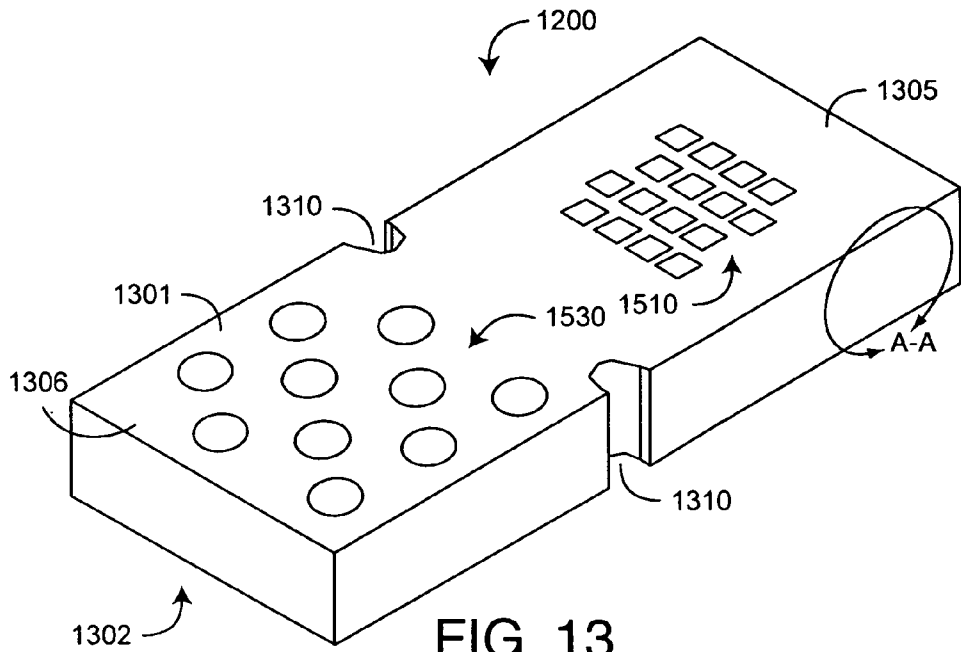

FIG. 13

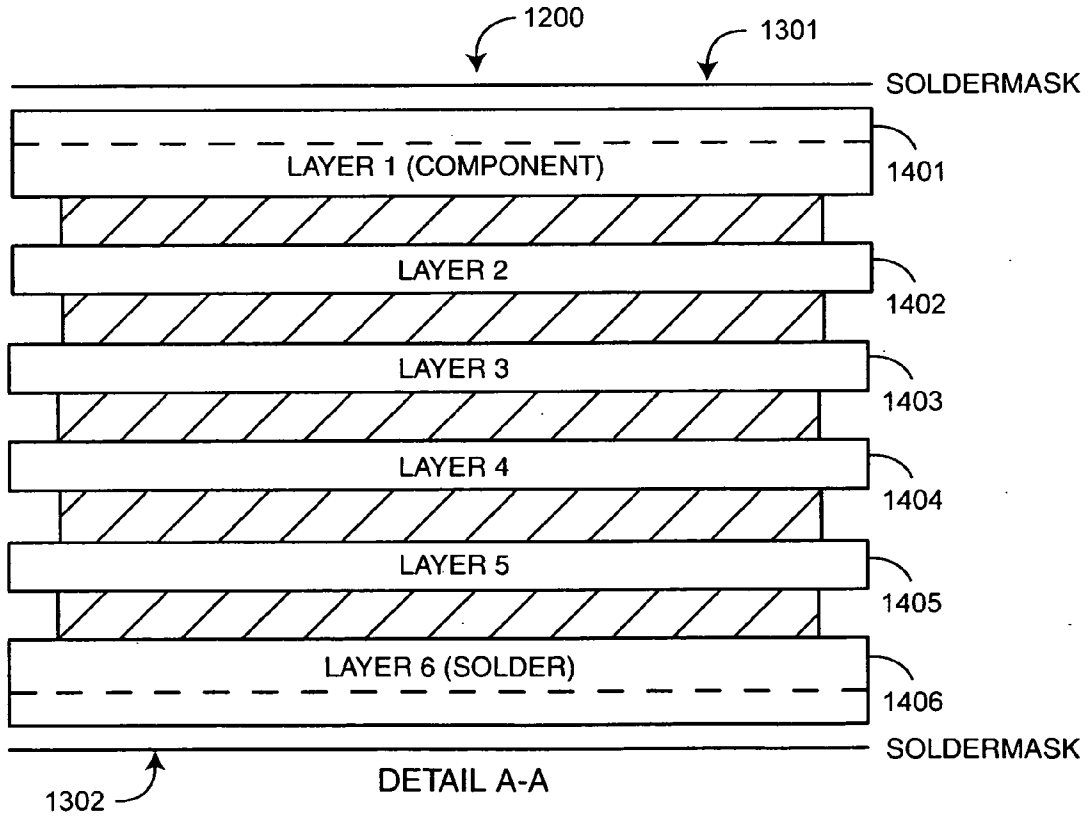

FIG. 14

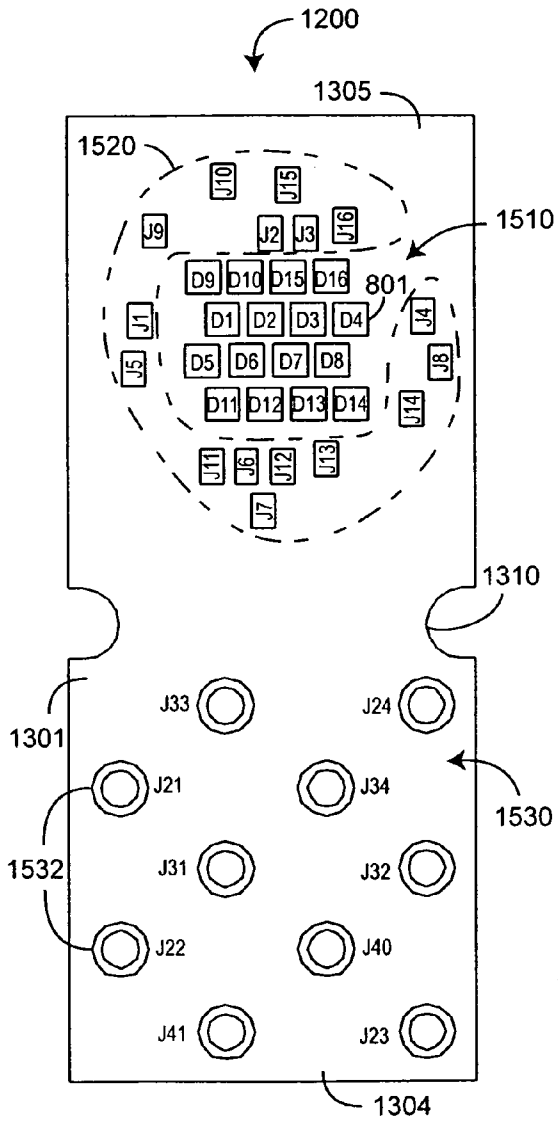

FIG. 15

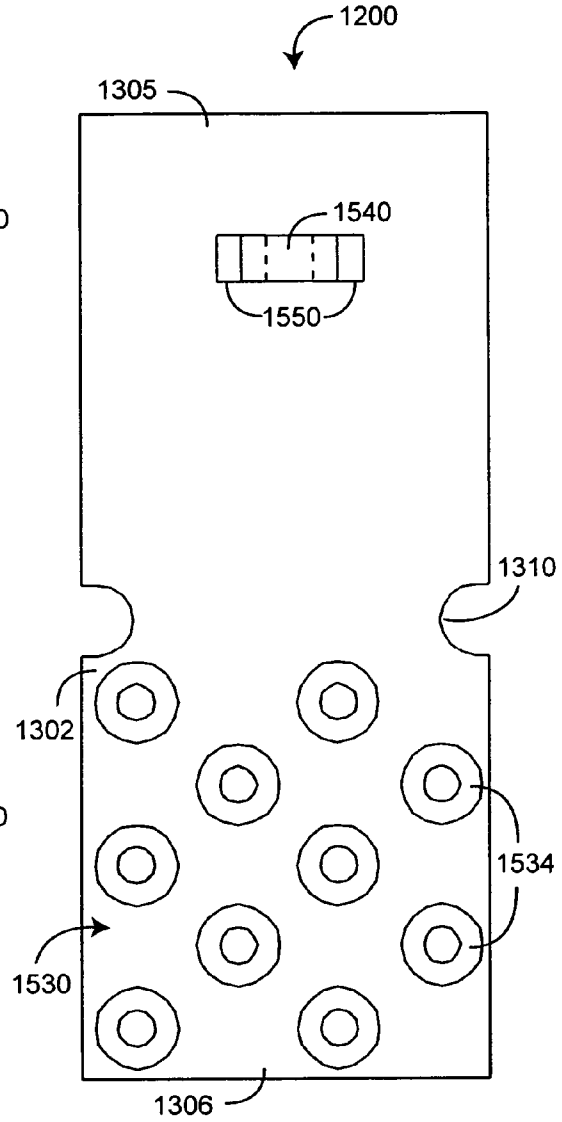

FIG. 16

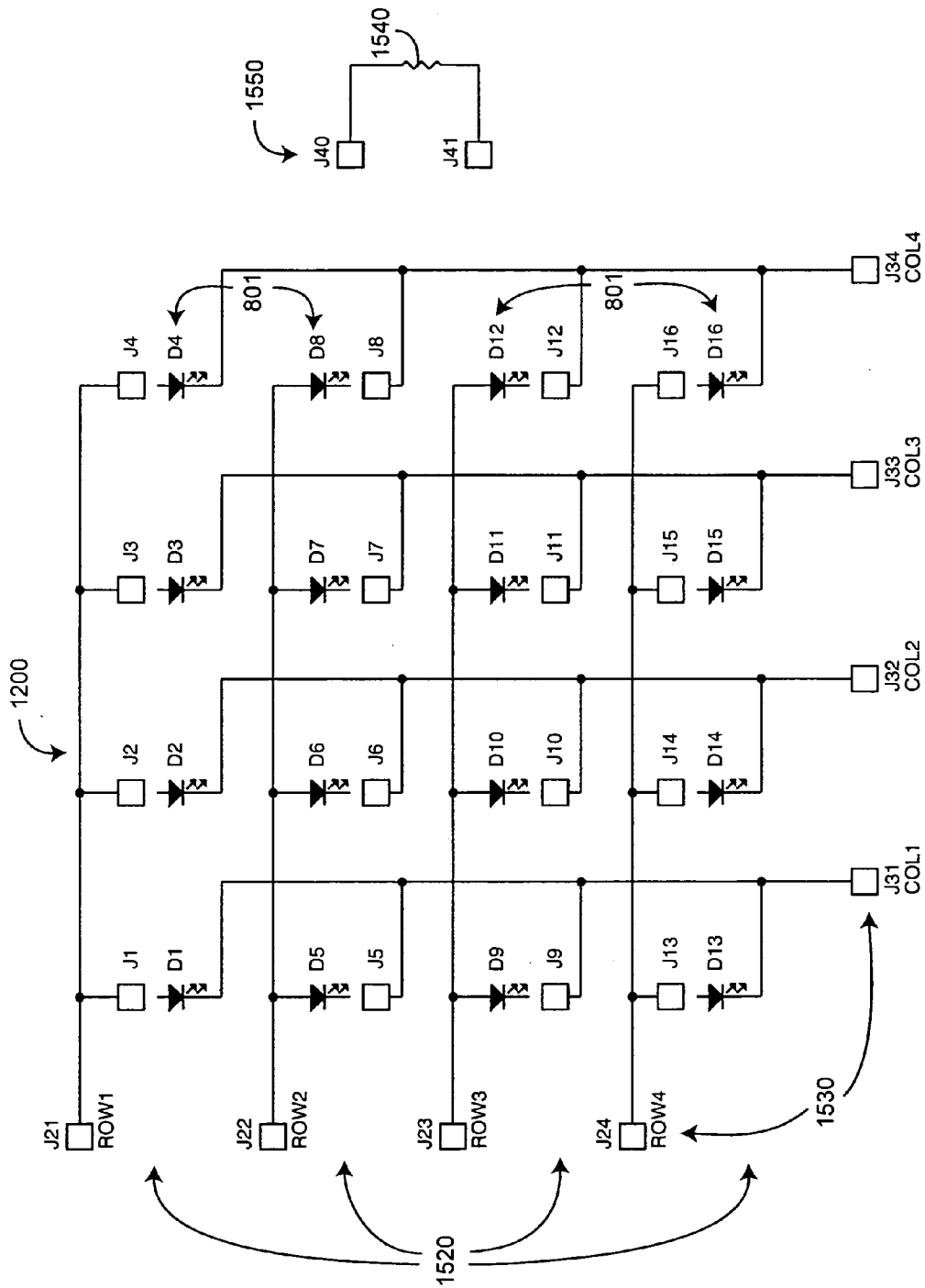

FIG. 17

1402

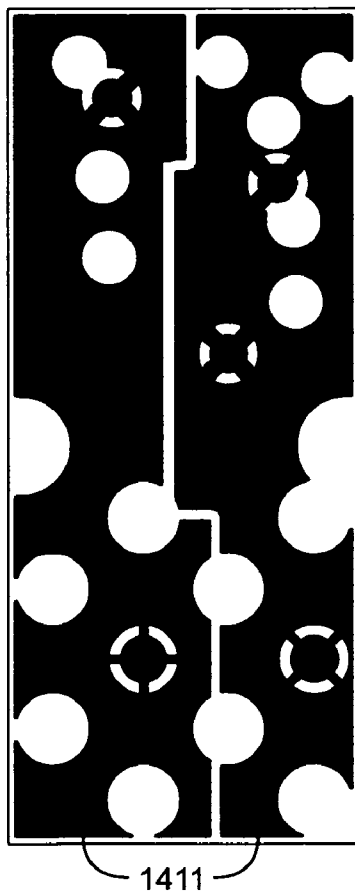

FIG. 18

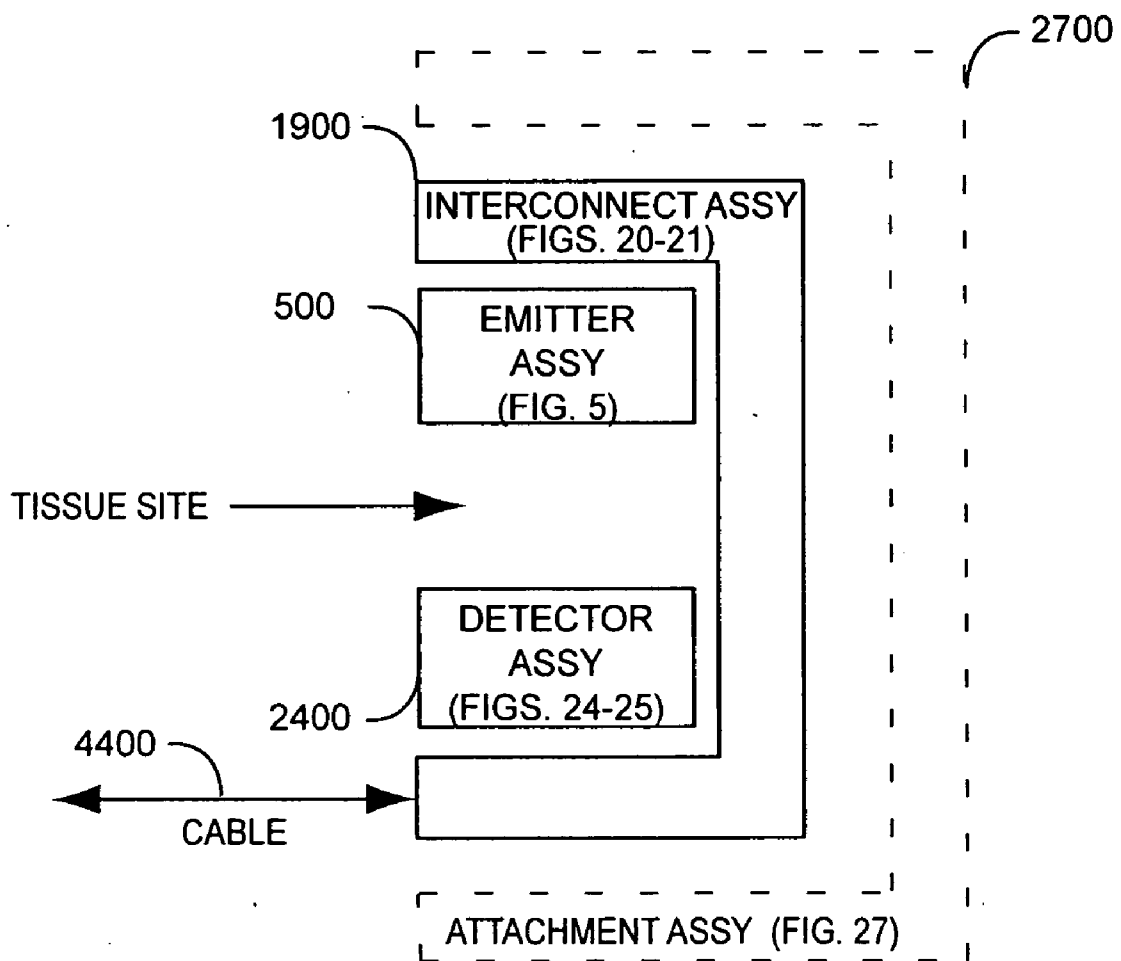

FIG. 19

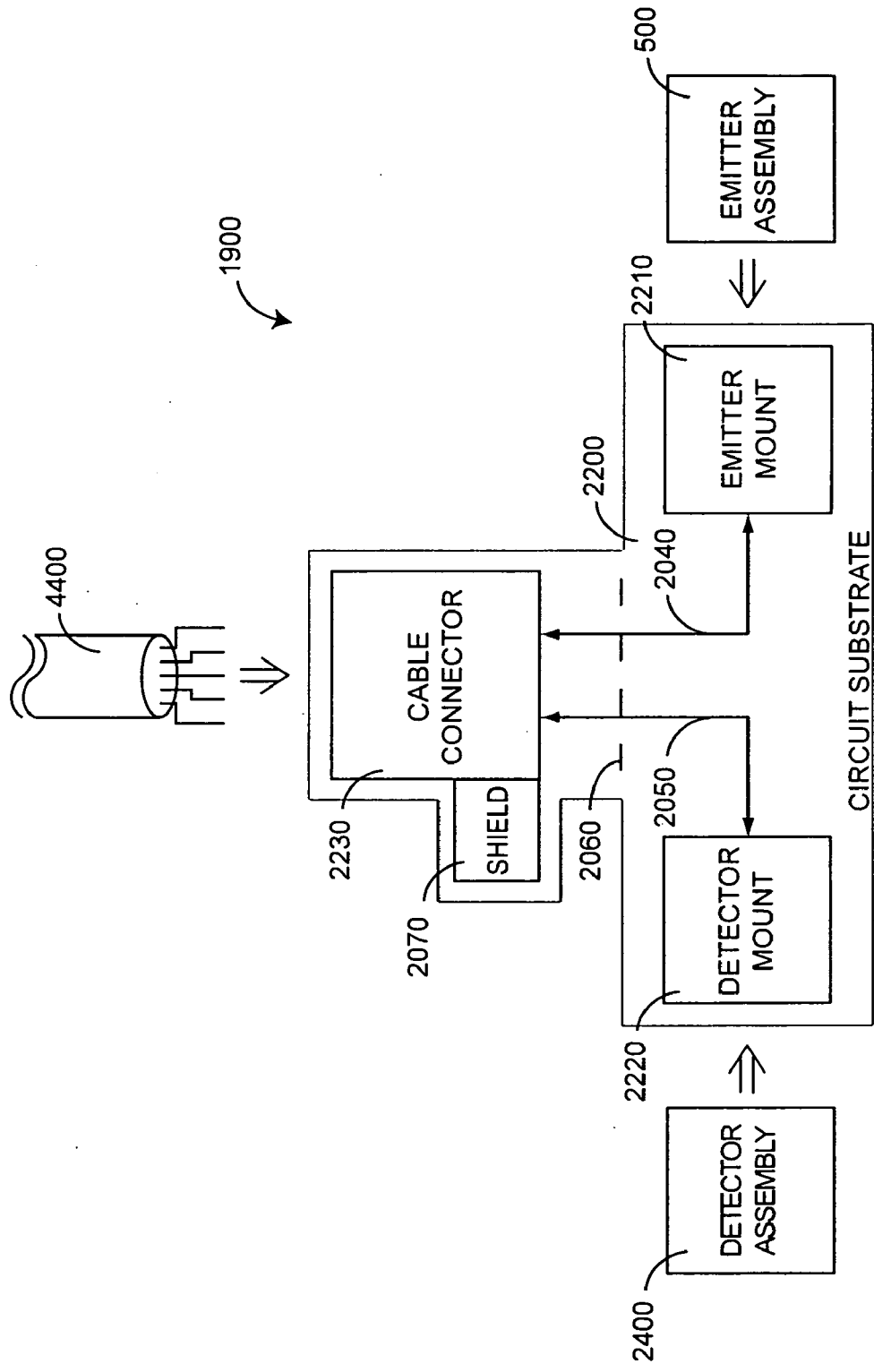

FIG. 20

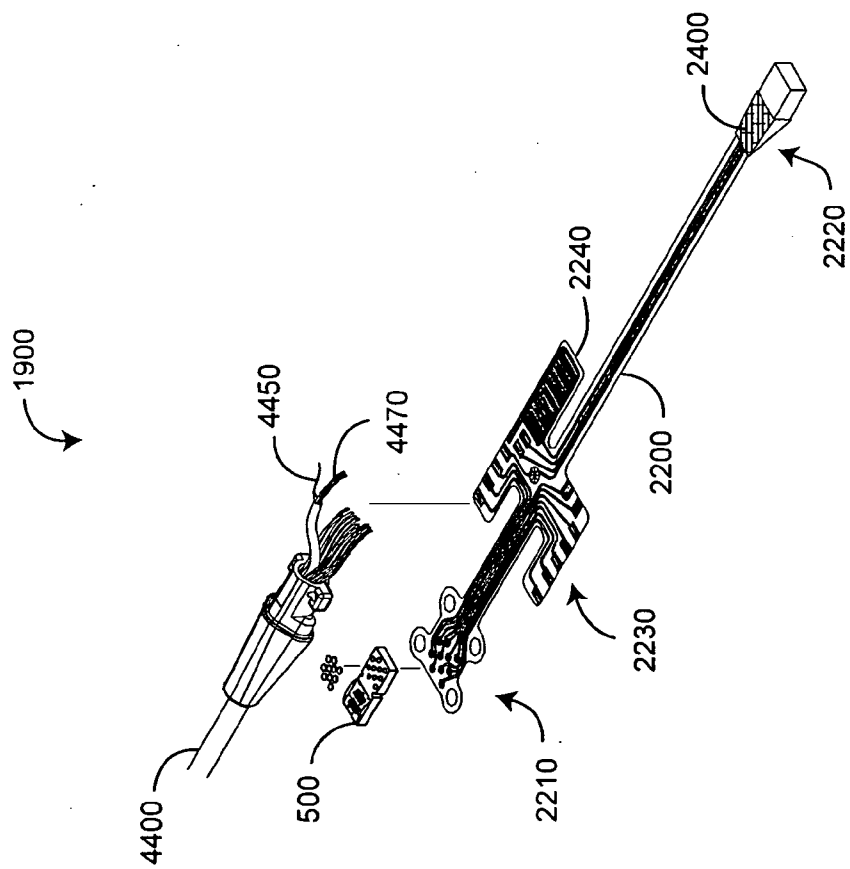

FIG. 21

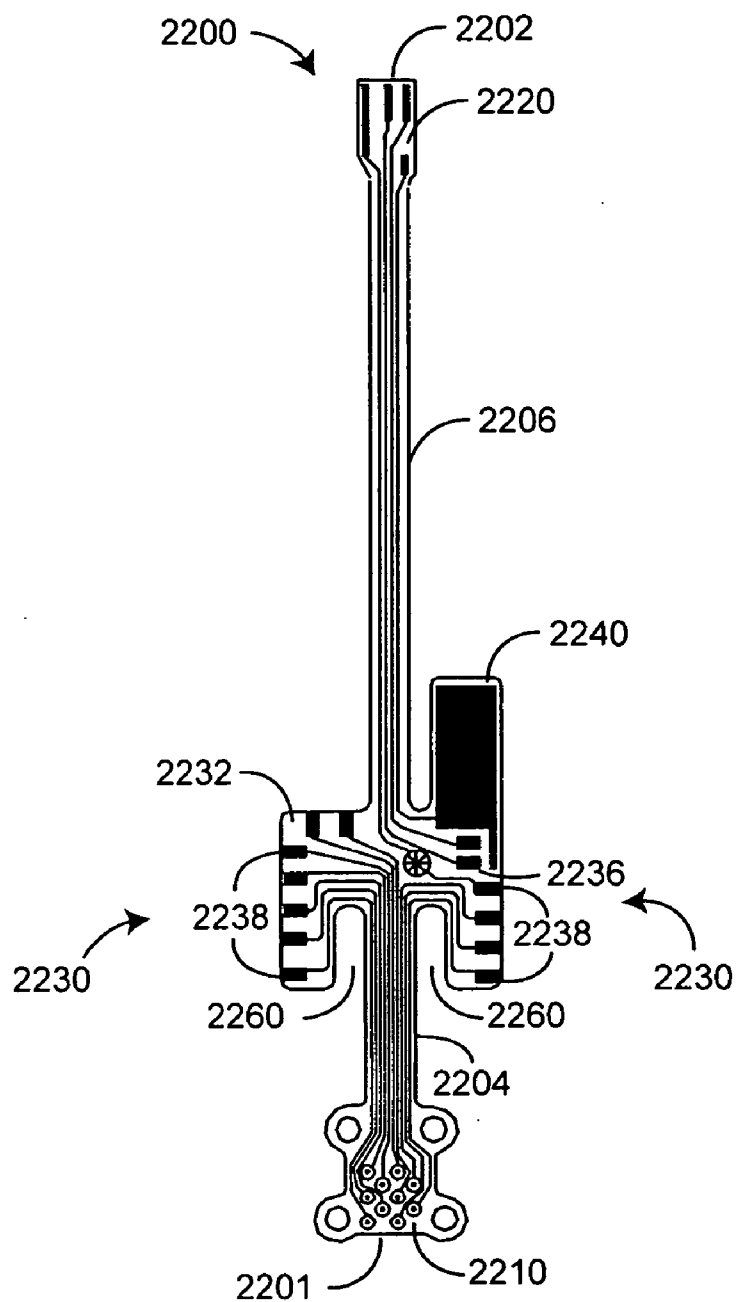

FIG. 22

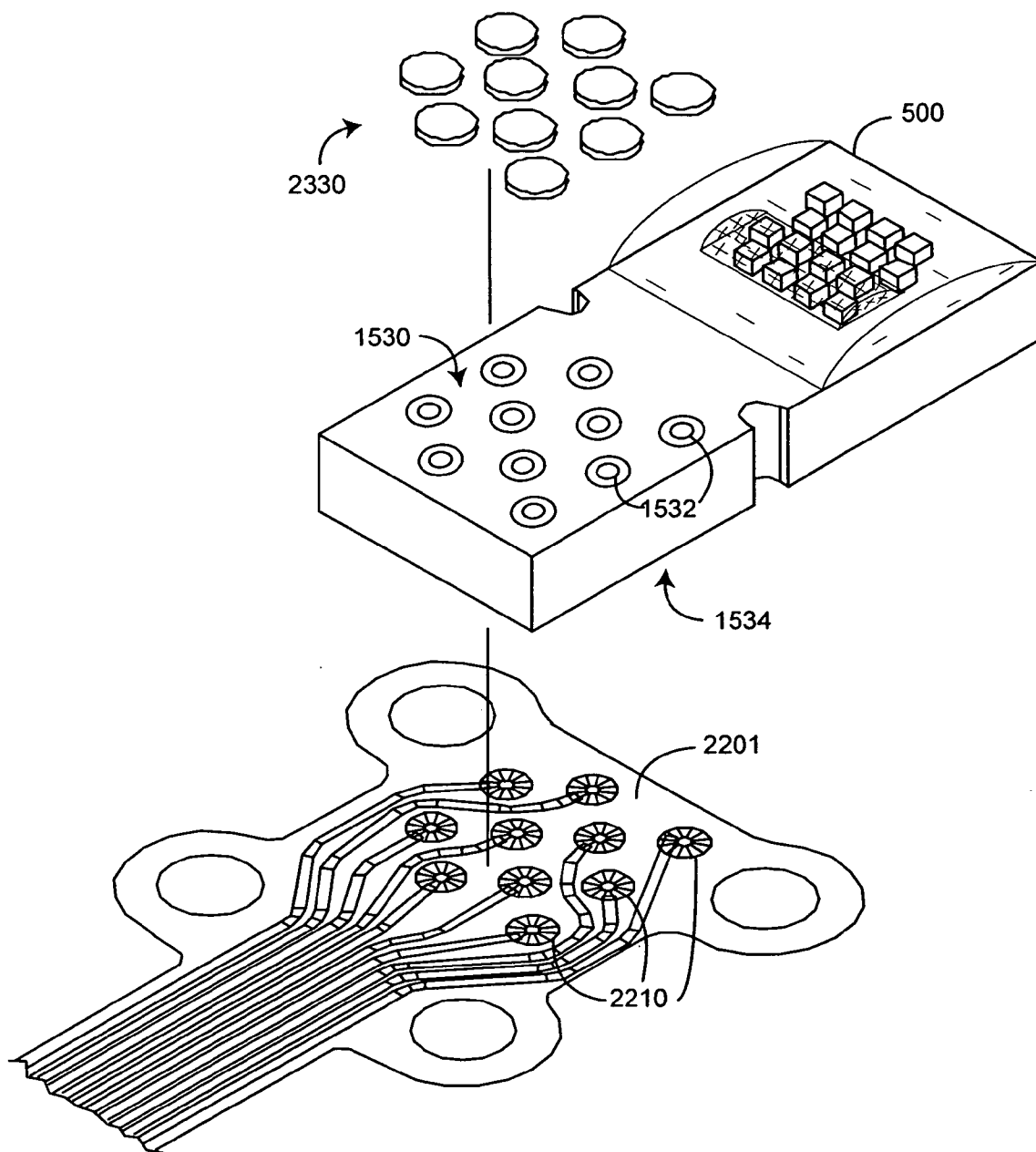

FIG. 23

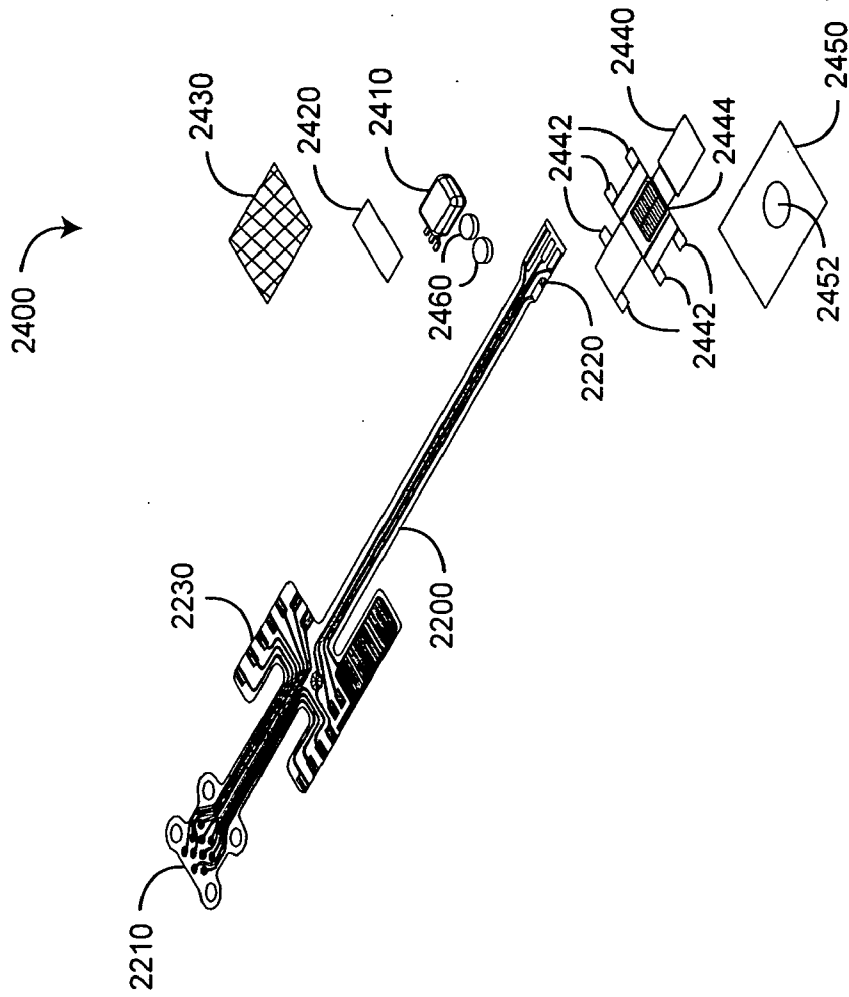

FIG. 24

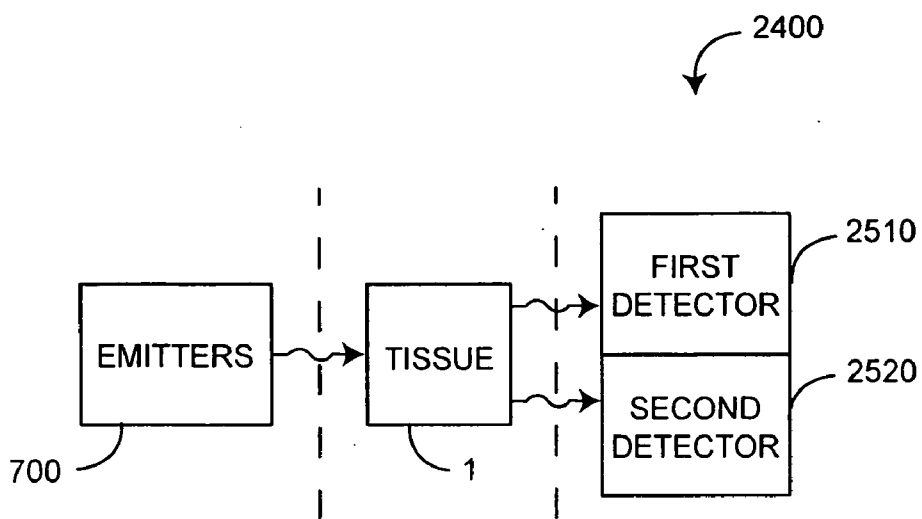

FIG. 25

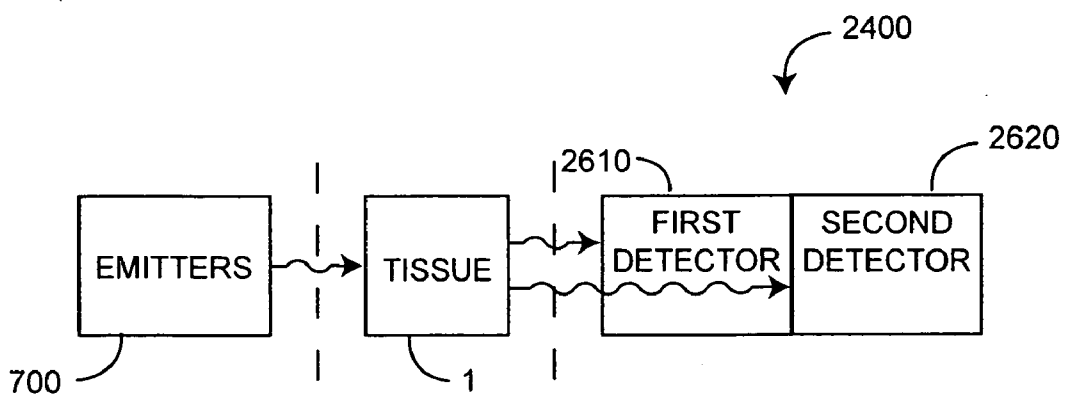

FIG. 26

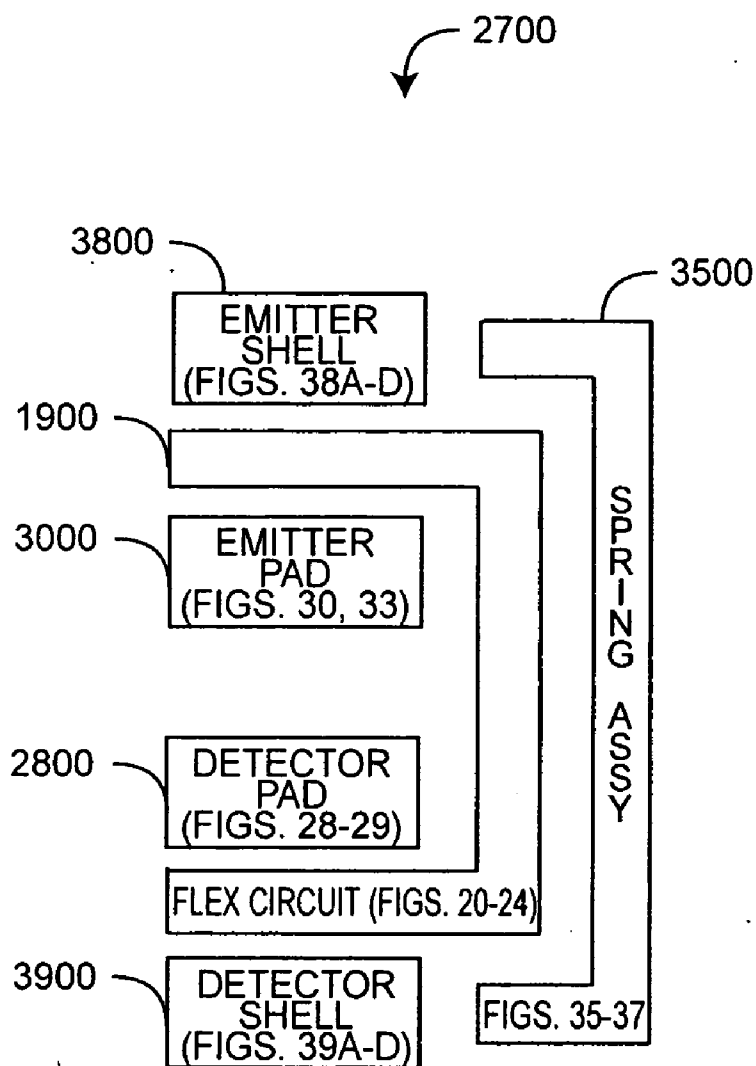

FIG. 27

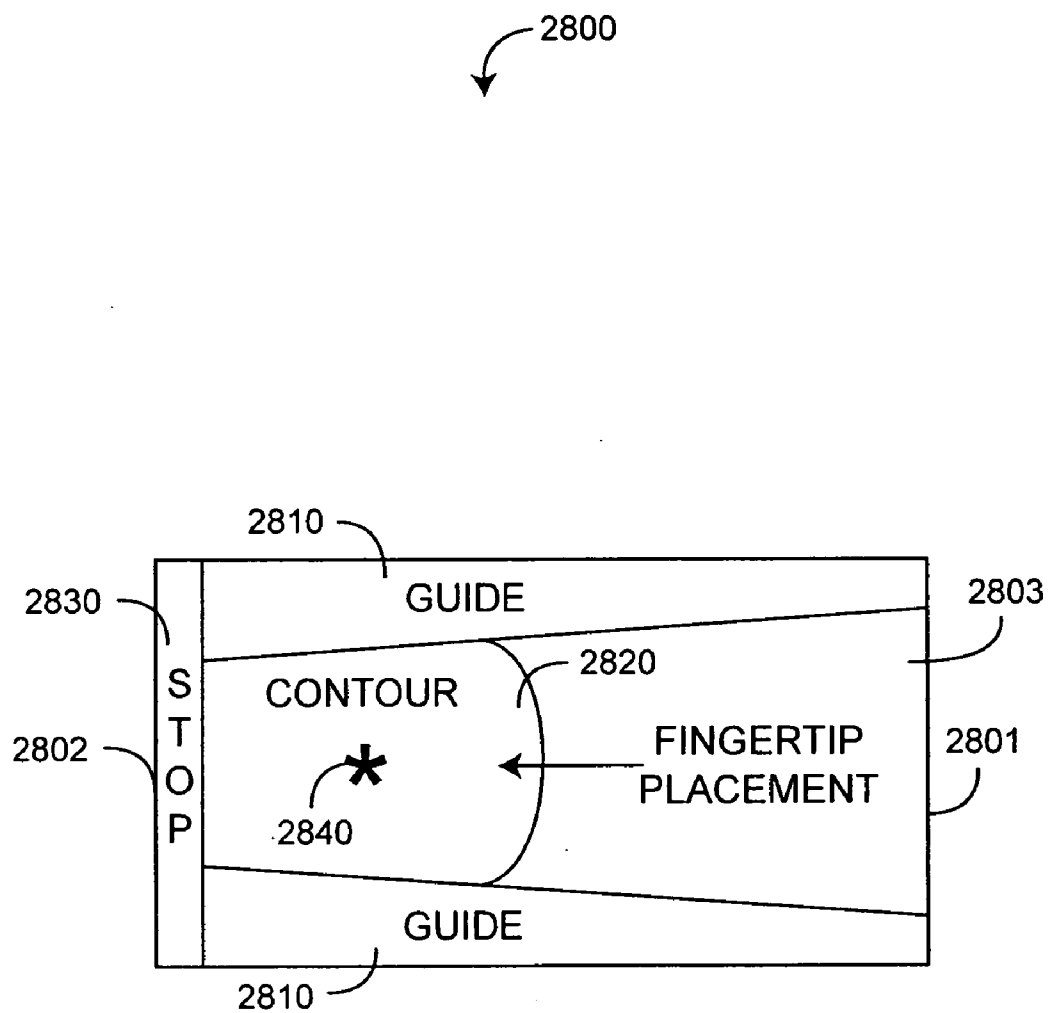

FIG. 28

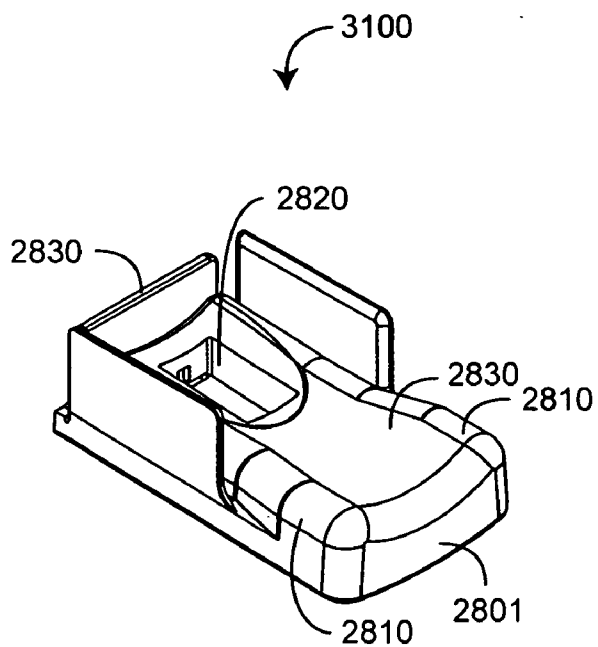

FIG. 29A

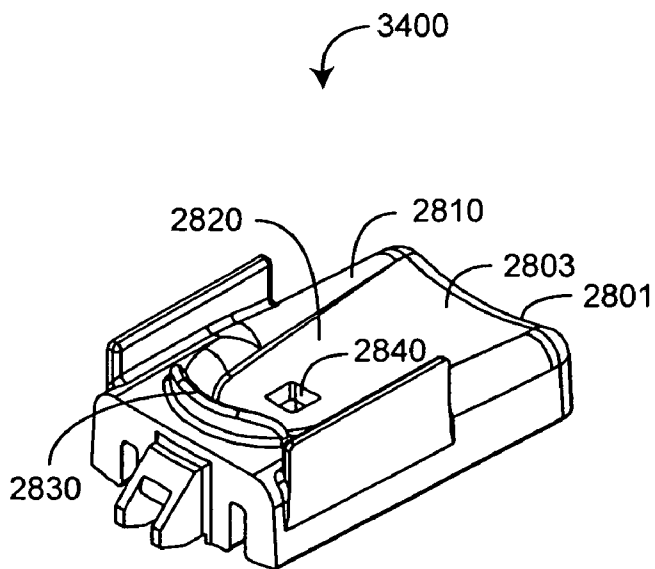

FIG. 29B

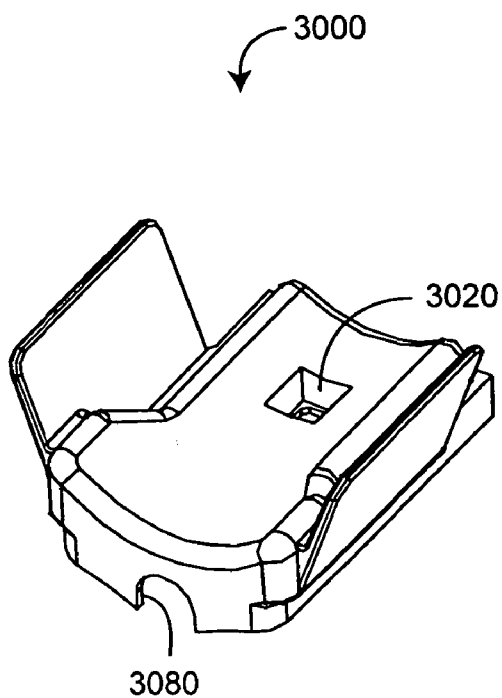

FIG. 30A

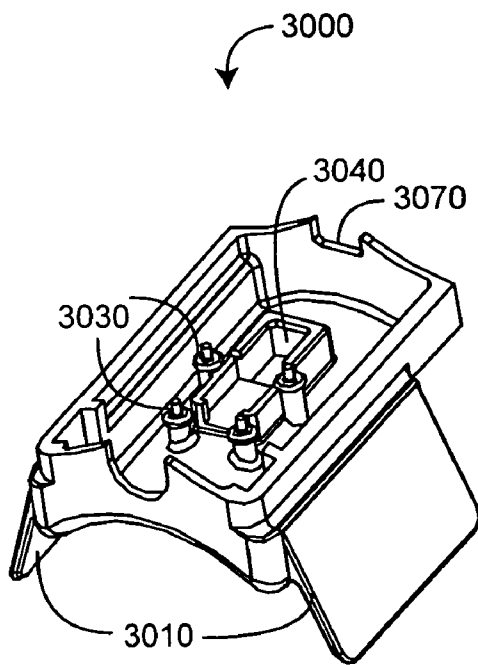

FIG. 30B

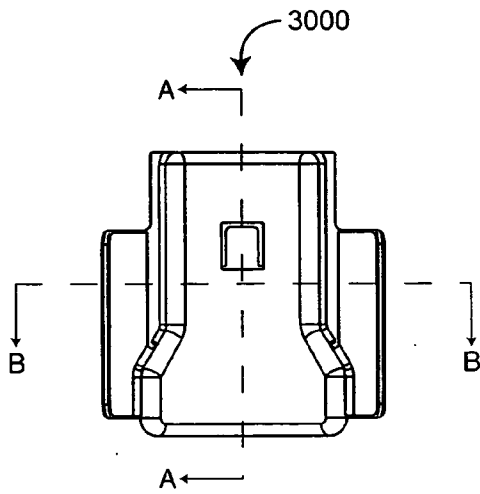
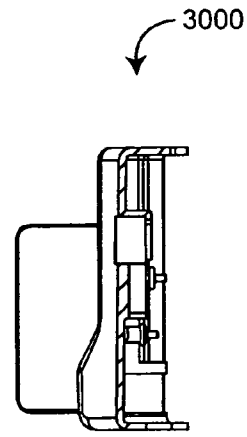

FIG. 30C



SECTION A-A

FIG. 30F

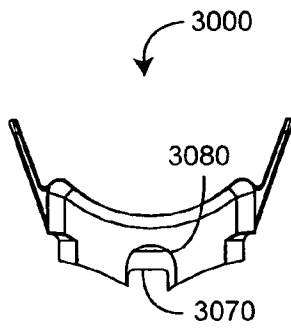

FIG. 30D

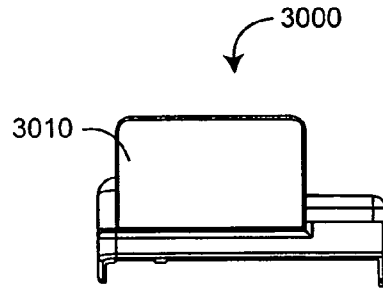

FIG. 30G

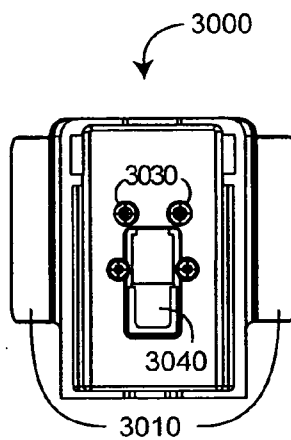
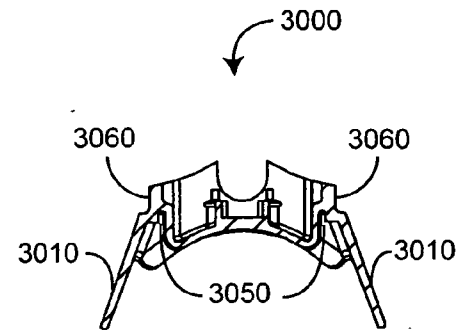

FIG. 30E



SECTION B-B

FIG. 30H

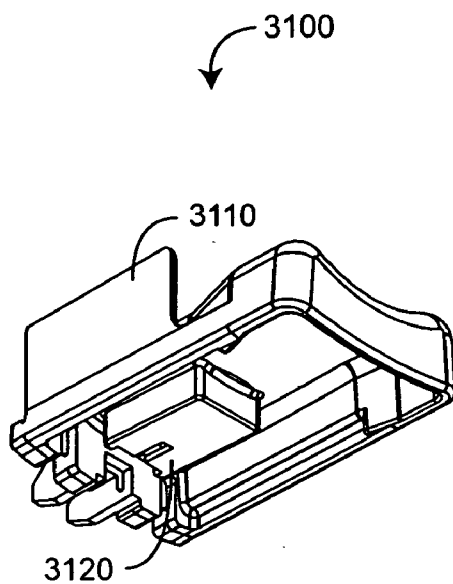

FIG. 31A

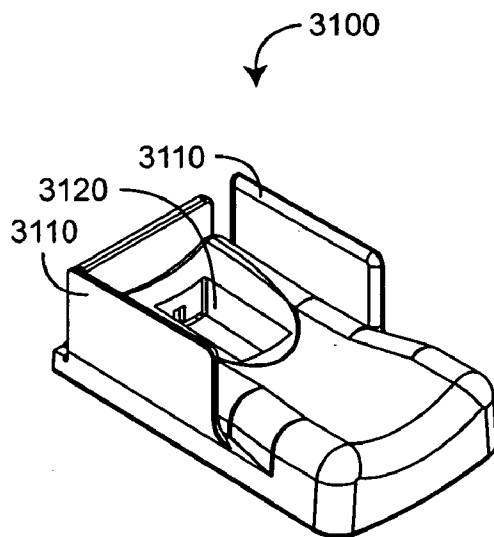

FIG. 31B

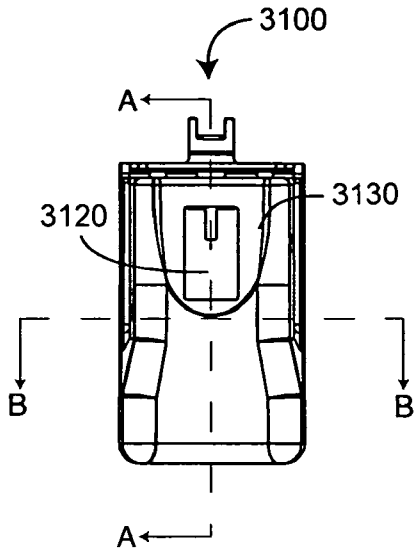
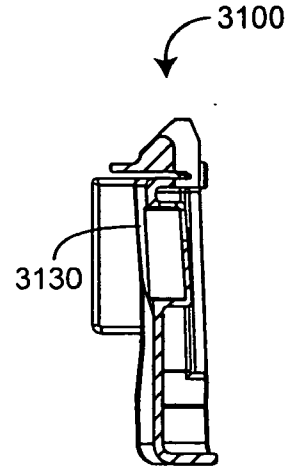

FIG. 31C



SECTION A-A

FIG. 31F

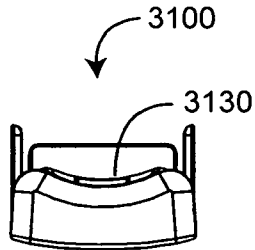

FIG. 31D

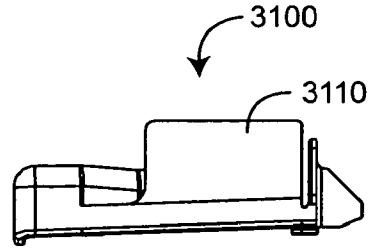

FIG. 31G

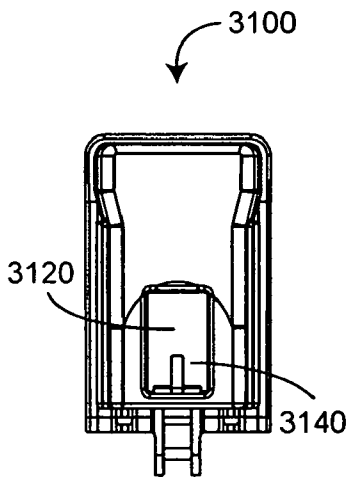
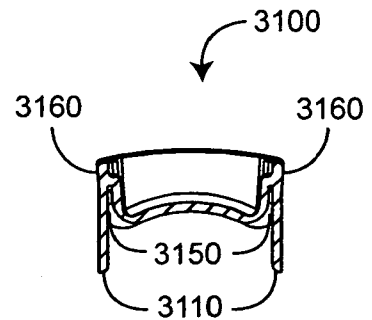

FIG. 31E



SECTION B-B

FIG. 31H

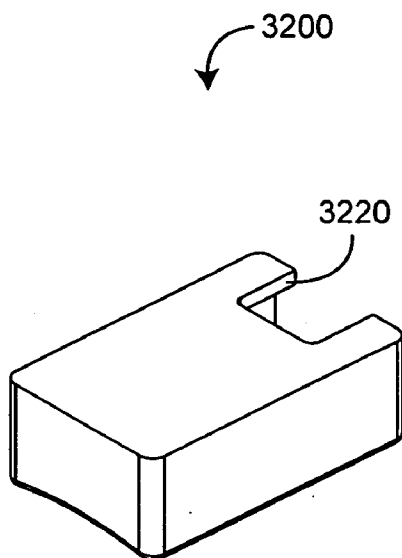

FIG. 32A

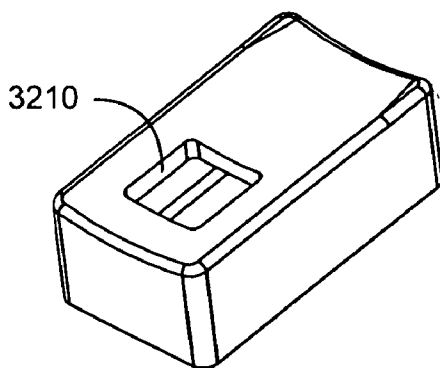

FIG. 32B

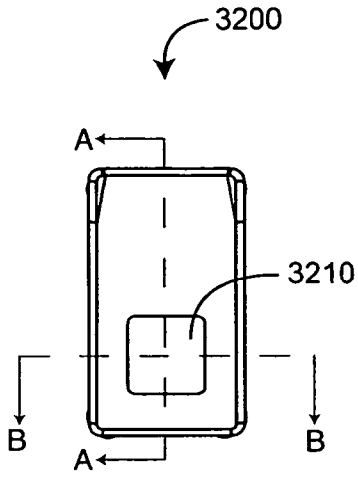
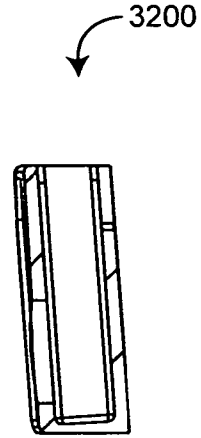

FIG. 32C



SECTION A-A
FIG. 32F

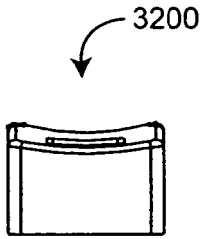

FIG. 32D

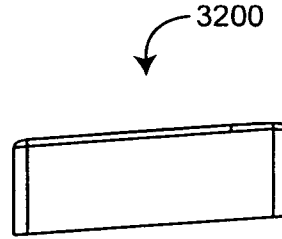

FIG. 32G

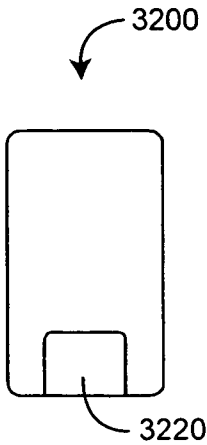
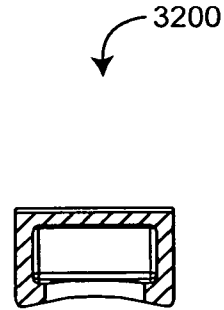

FIG. 32E



SECTION B-B
FIG. 32H

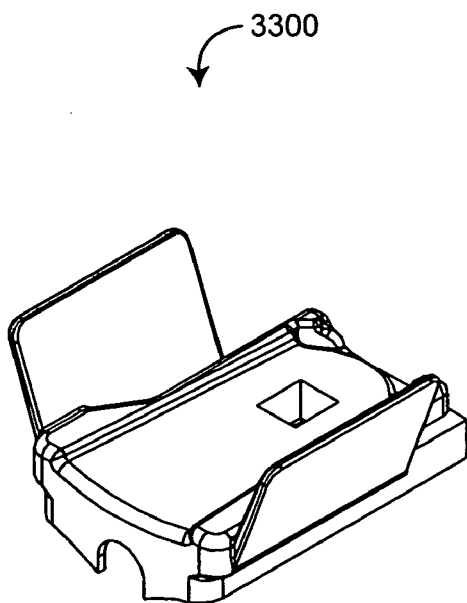

FIG. 33A

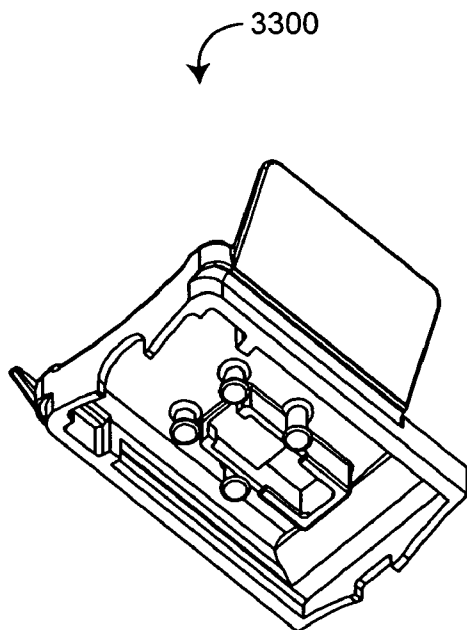

FIG. 33B

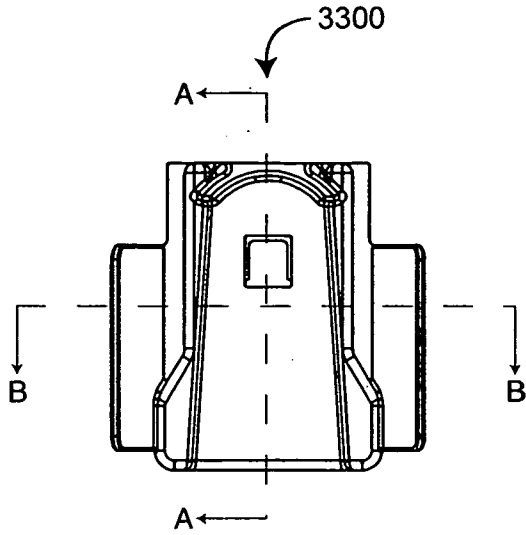

FIG. 33C

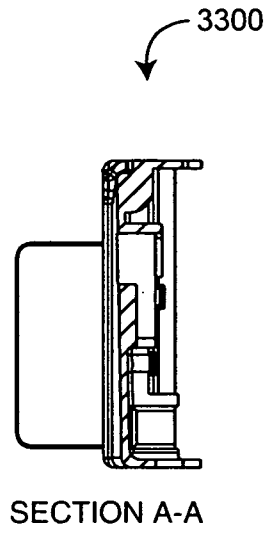

FIG. 33F

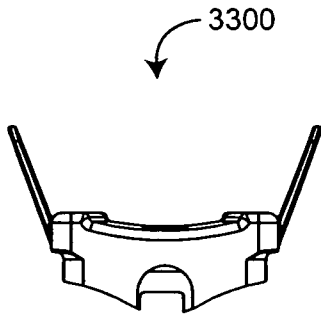

FIG. 33D

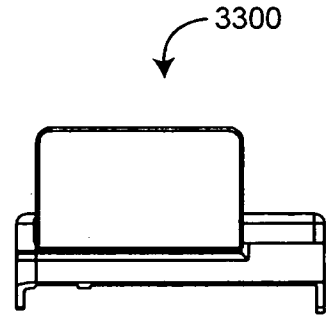

FIG. 33G

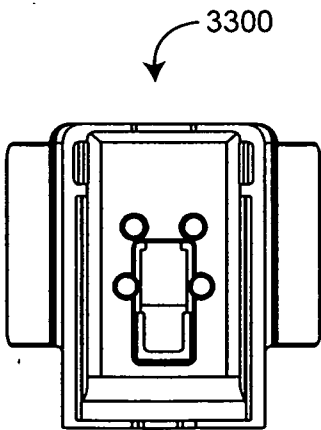

FIG. 33E

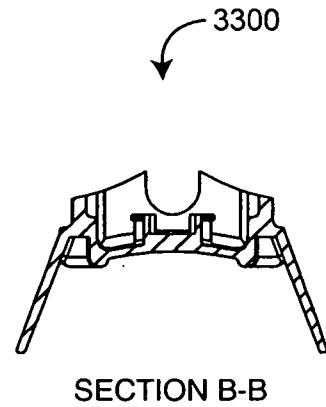

FIG. 33H

3400

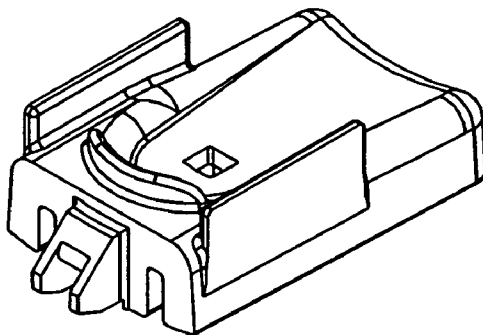

FIG. 34A

3400

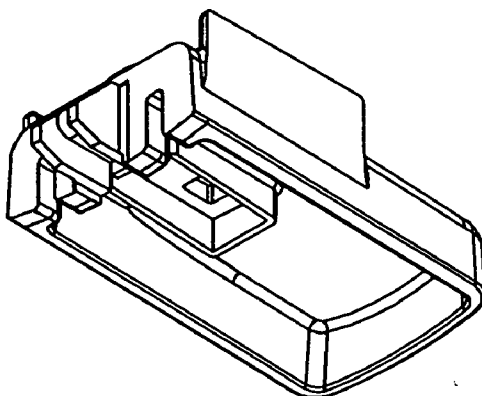

FIG. 34B

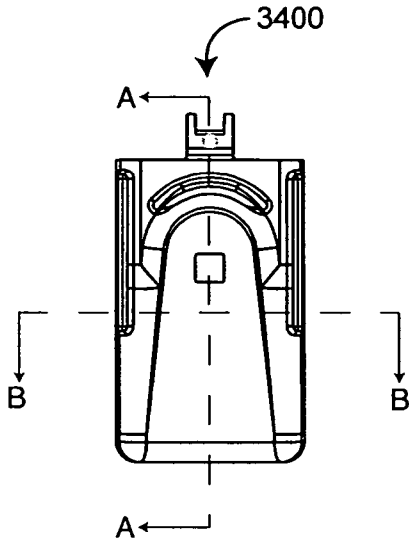
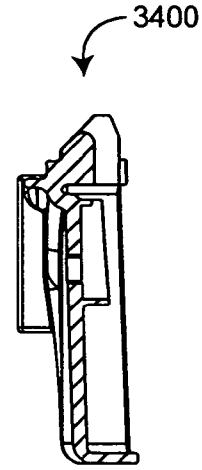

FIG. 34C



SECTION A-A

FIG. 34F

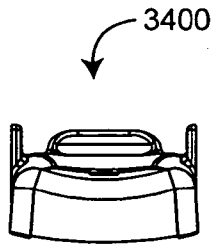

FIG. 34D

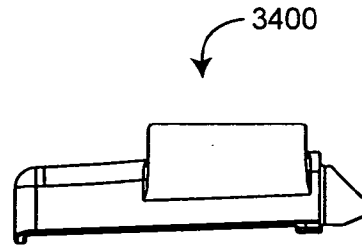

FIG. 34G

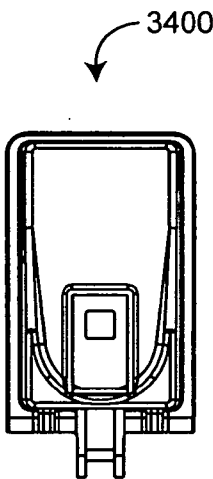
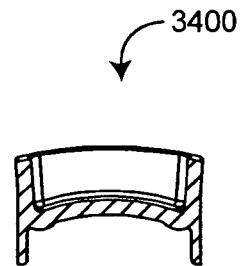

FIG. 34E



SECTION B-B

FIG. 34H

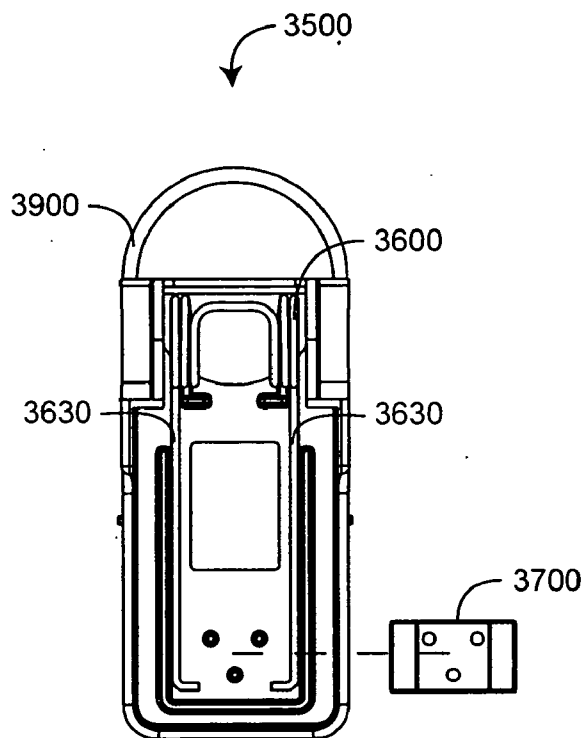

FIG. 35A

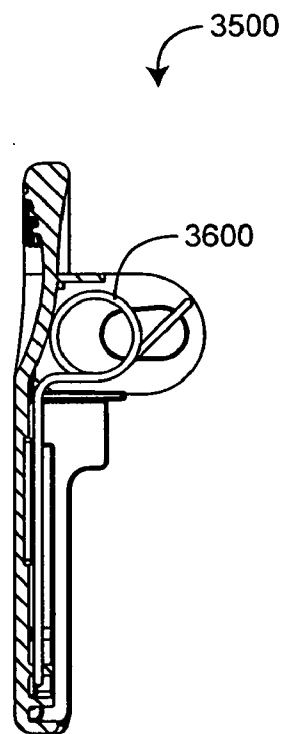

FIG. 35B

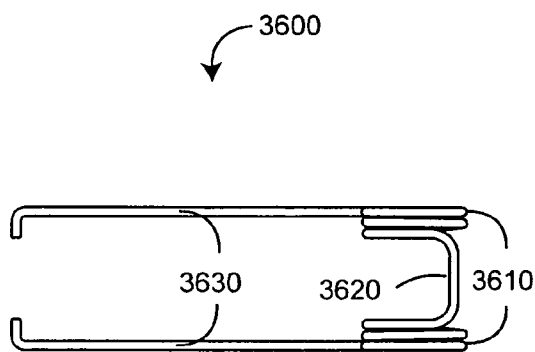

FIG. 36A

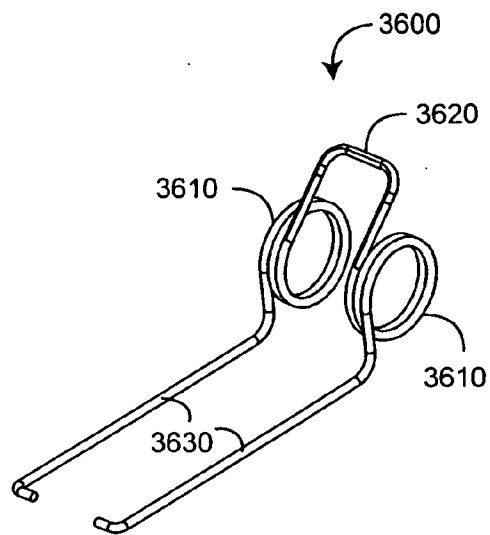

FIG. 36B

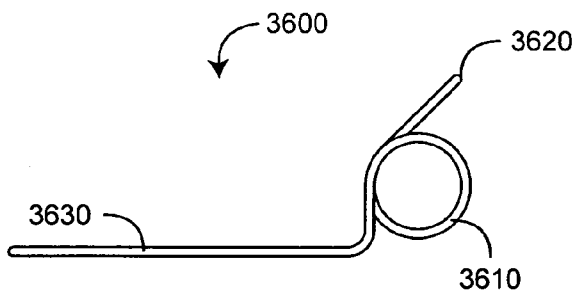

FIG. 36C

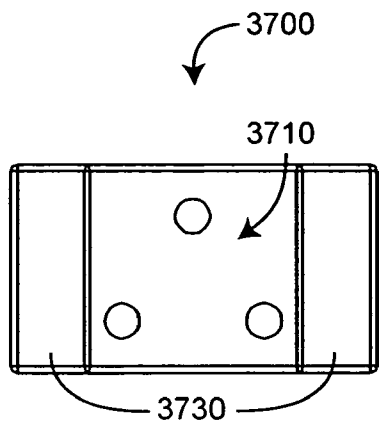

FIG. 37A

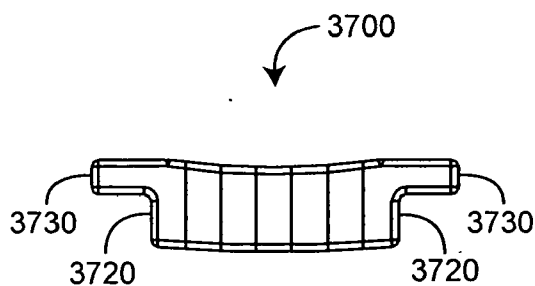

FIG. 37B

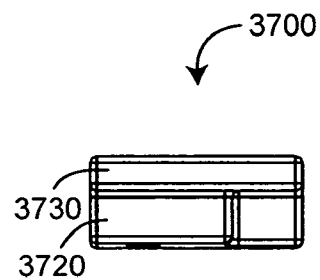

FIG. 37D

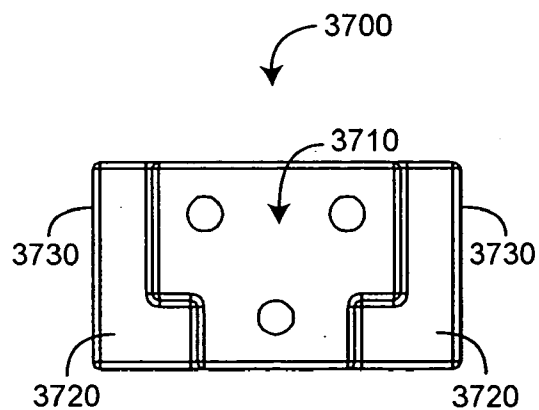

FIG. 37C

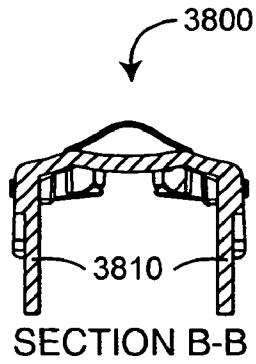

FIG. 38A

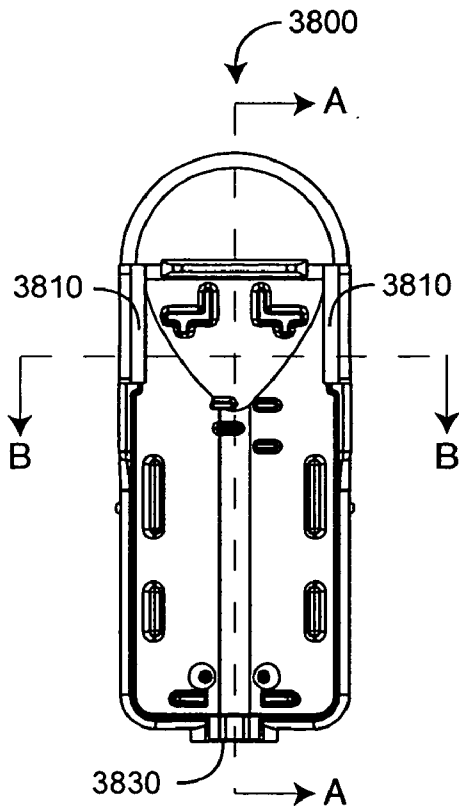
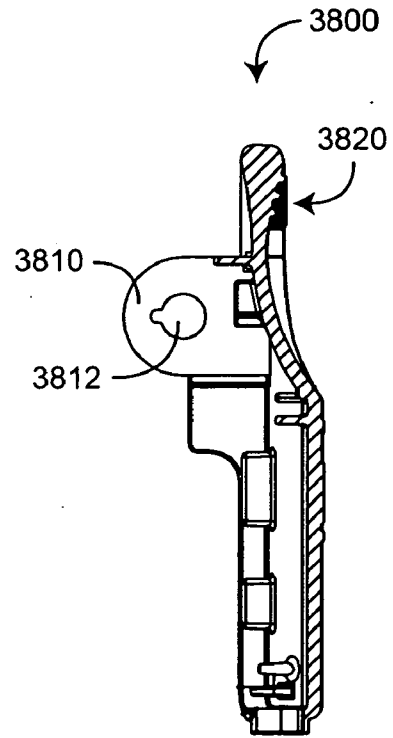

FIG. 38B



SECTION A-A
FIG. 38D

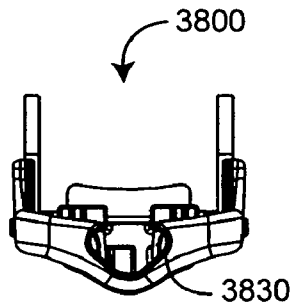

FIG. 38C

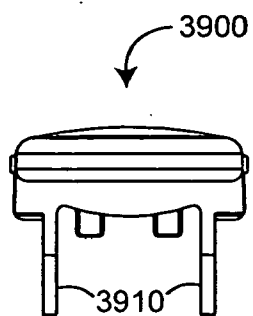

FIG. 39A

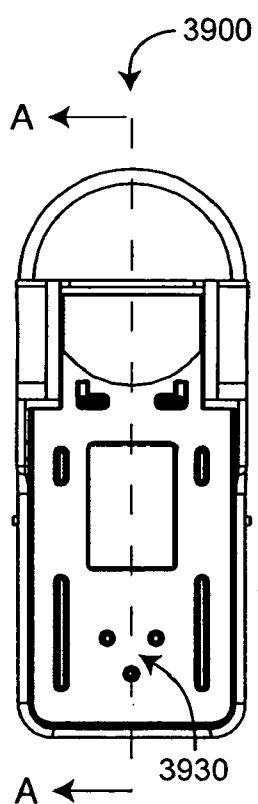

FIG. 39B

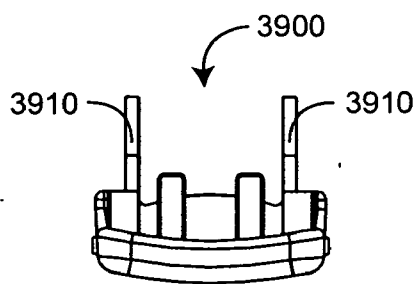
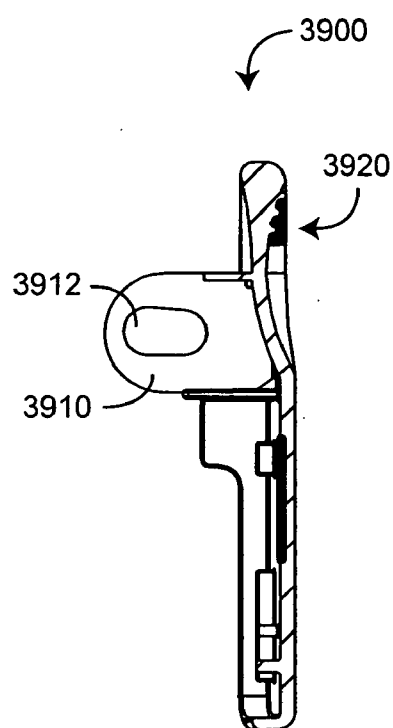

FIG. 39C



SECTION A-A
FIG. 39D

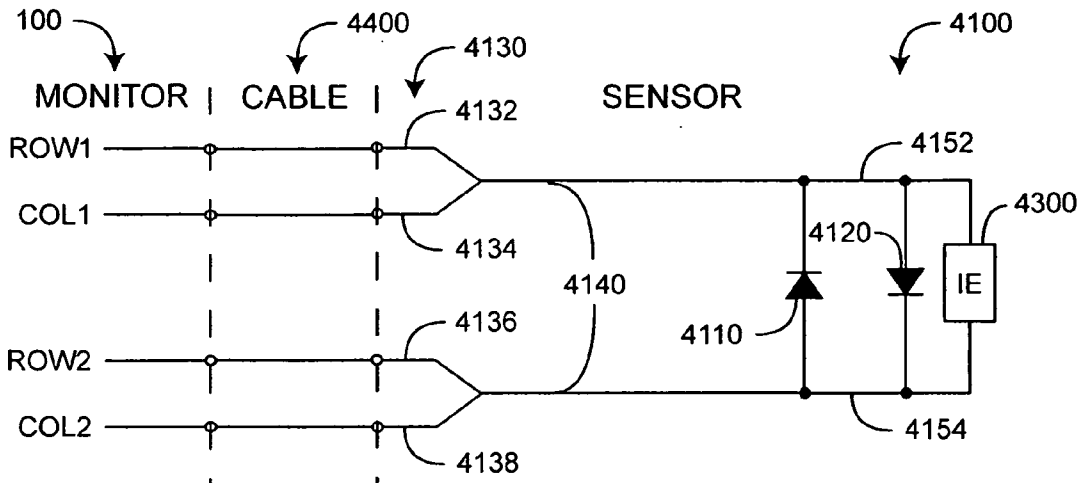

FIG. 41A

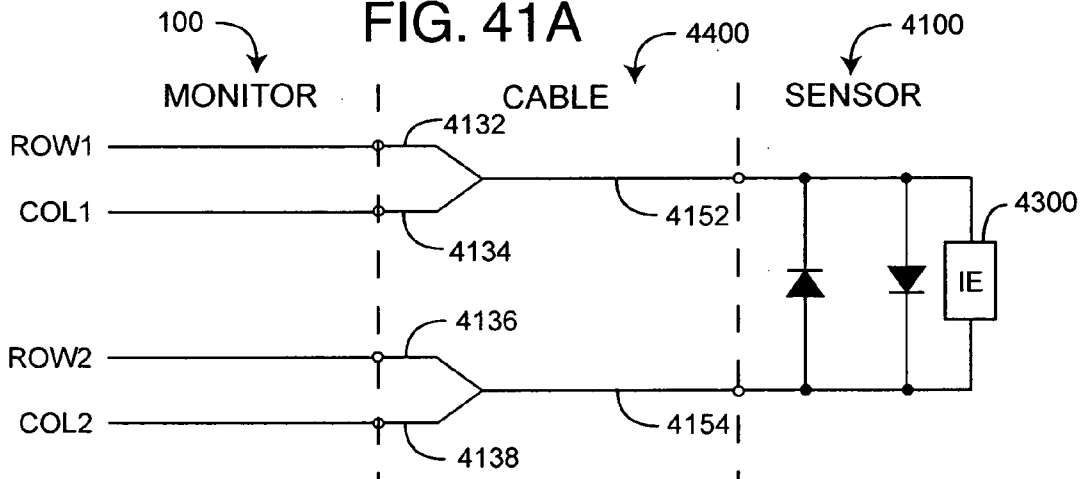

FIG. 41B

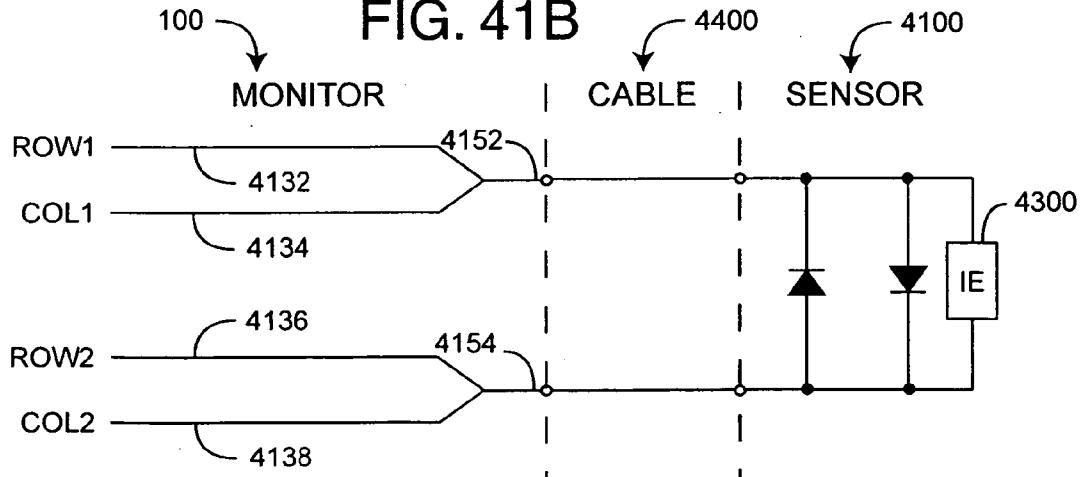

FIG. 41C

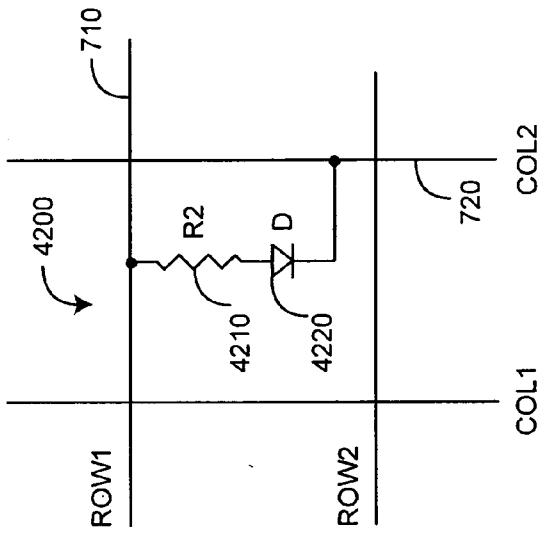

FIG. 42

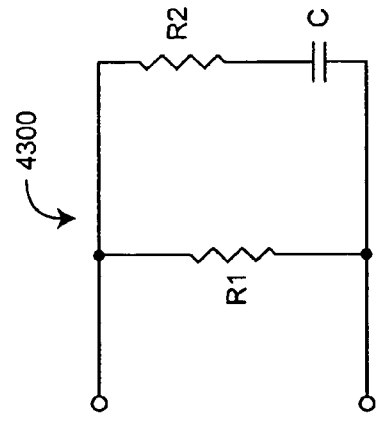

FIG. 43A

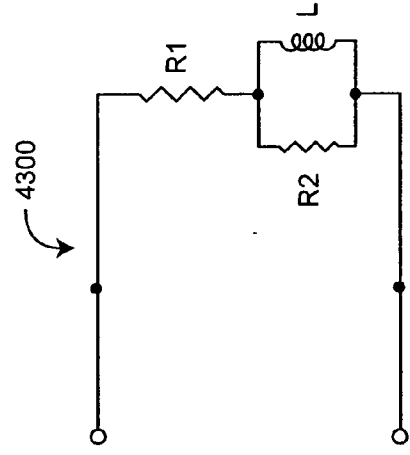

FIG. 43B

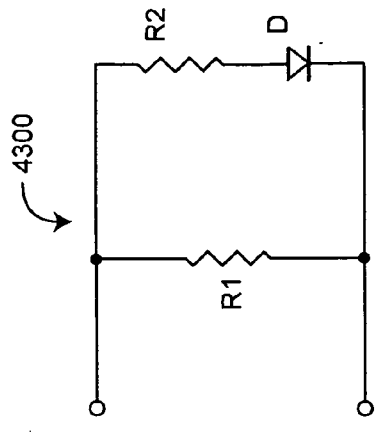

FIG. 43C

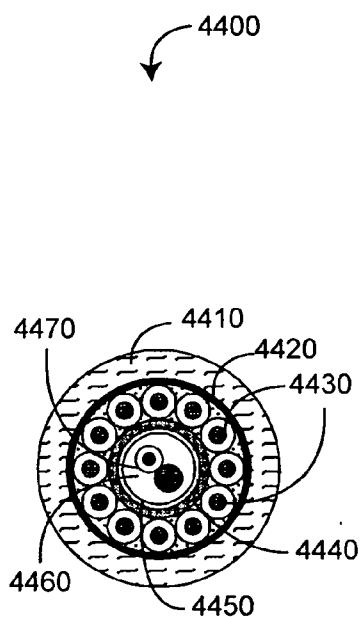

FIG. 44A

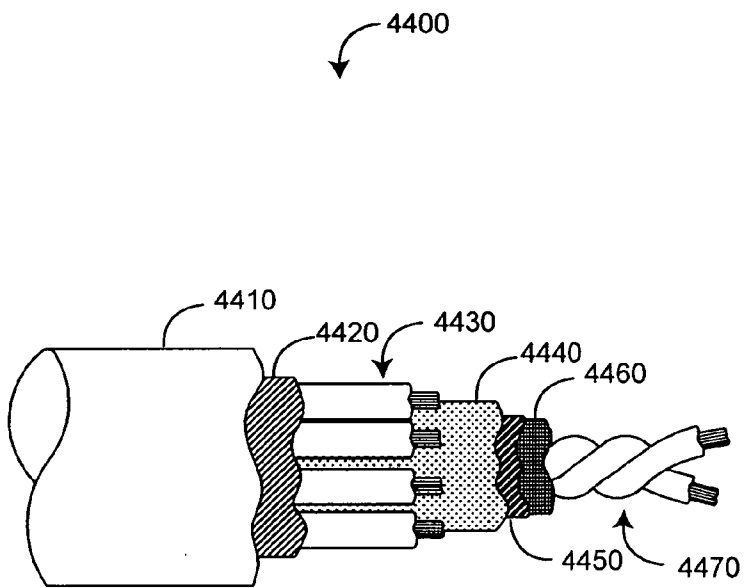

FIG. 44B

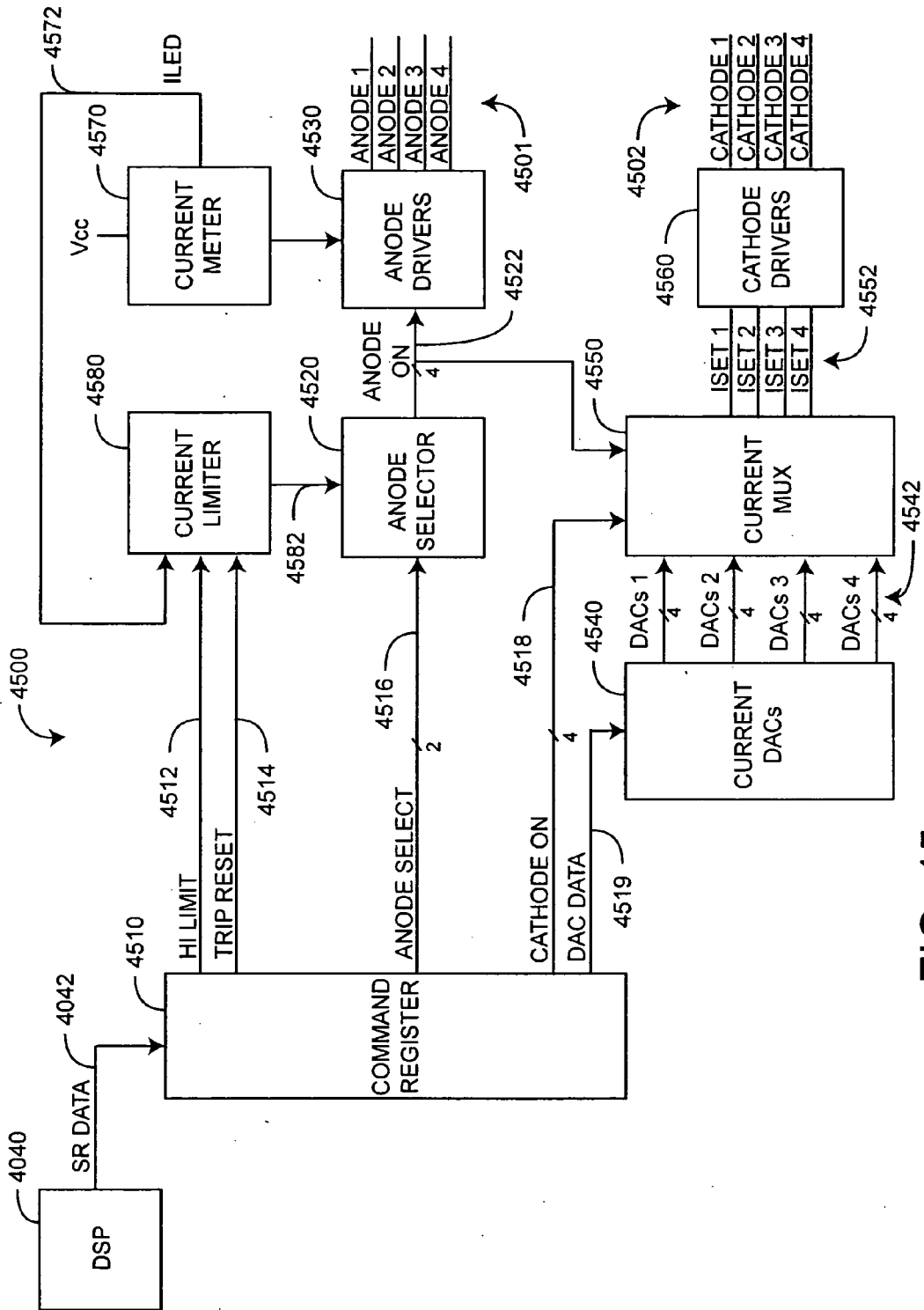

FIG. 45

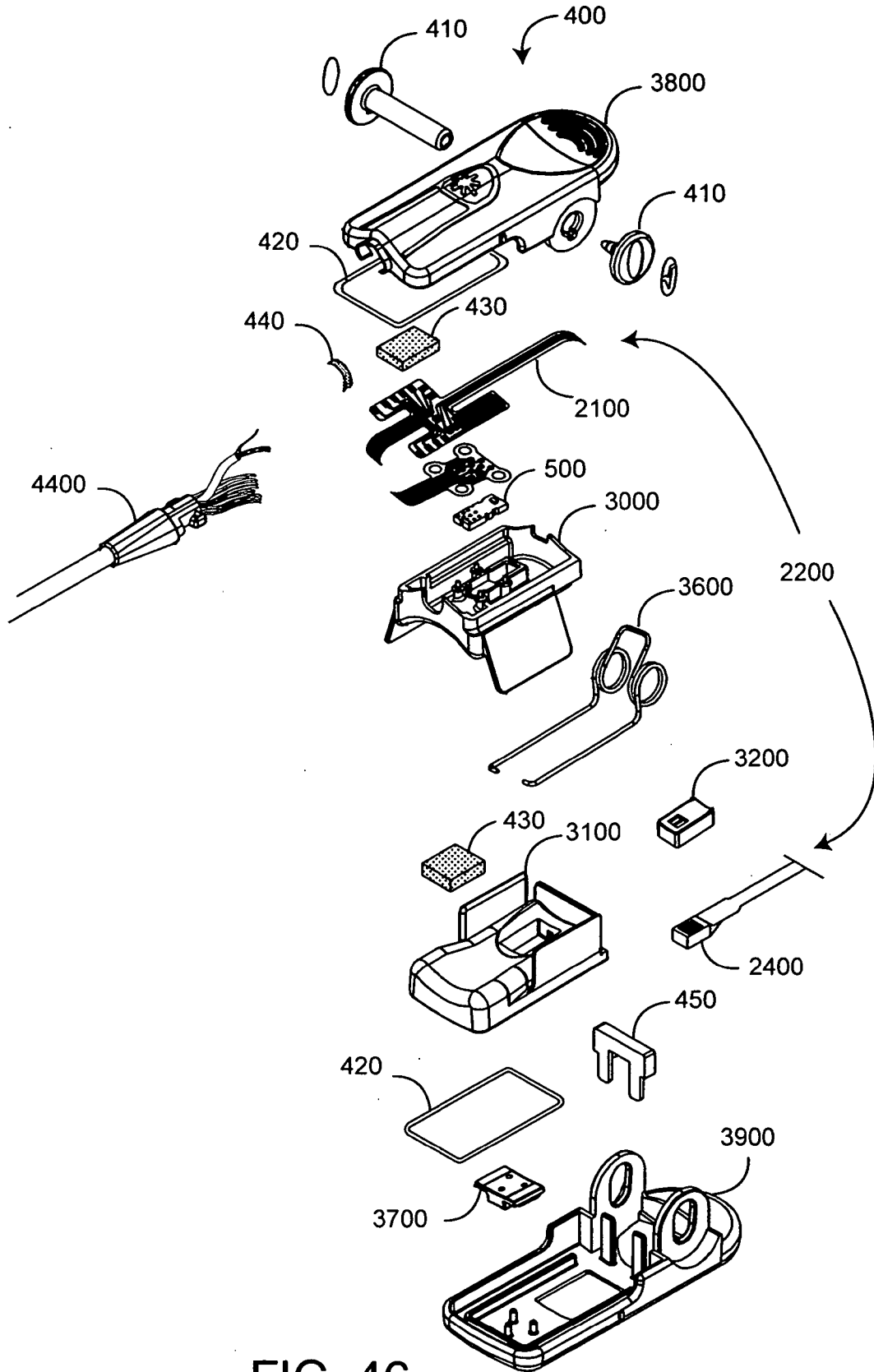

FIG. 46

MULTIPLE WAVELENGTH SENSOR EMITTERS

**PRIORITY CLAIM TO RELATED
PROVISIONAL APPLICATIONS**

[0001] The present application claims priority benefit under 35 U.S.C. § 119(e) to U.S. Provisional Patent Application Serial No. 60/657,596, filed Mar. 1, 2005, entitled “Multiple Wavelength Sensor,” No. 60/657,281, filed Mar. 1, 2005, entitled “*Physiological Parameter Confidence Measure*,” No. 60/657,268, filed March 1, 2005, entitled “*Configurable Physiological Measurement System*,” and No. 60/57,759, filed Mar. 1, 2005, entitled “*Noninvasive Multi-Parameter Patient Monitor*.” The present application incorporates the foregoing disclosures herein by reference.

**INCORPORATION BY REFERENCE OF
COPENDING RELATED APPLICATIONS**

[0002] The present application is related to the following copending U.S. utility applications:

App. Sr. No.	Filing Date	Title	Atty Dock.
1	11/####,####	Mar. 1, 2006 Multiple Wavelength Sensor Emitters	MLR.002A
2	11/####,####	Mar. 1, 2006 Multiple Wavelength Sensor Equalization	MLR.003A
3	11/####,####	Mar. 1, 2006 Multiple Wavelength Sensor Substrate	MLR.004A
4	11/####,####	Mar. 1, 2006 Multiple Wavelength Sensor Interconnect	MLR.005A
5	11/####,####	Mar. 1, 2006 Multiple Wavelength Sensor Attachment	MLR.006A
6	11/####,####	Mar. 1, 2006 Multiple Wavelength Sensor Drivers	MLR.009A
7	11/####,####	Mar. 1, 2006 Physiological Parameter Confidence Measure	MLR.010A
8	11/####,####	Mar. 1, 2006 Configurable Physiological Measurement System	MLR.011A
9	11/####,####	Mar. 1, 2006 Noninvasive Multi-Parameter Patient Monitor	MLR.012A
10	11/####,####	Mar. 1, 2006 Noninvasive Multi-Parameter Patient Monitor	MLR.013A
11	11/####,####	Mar. 1, 2006 Noninvasive Multi-Parameter Patient Monitor	MLR.014A

[0003] The present application incorporated the foregoing disclosure herein by reference.itor d e 4

BACKGROUND OF THE INVENTION

[0004] Spectroscopy is a common technique for measuring the concentration of organic and some inorganic constituents of a solution. The theoretical basis of this technique is the Beer-Lambert law, which states that the concentration c_i of an absorbent in solution can be determined by the intensity of light transmitted through the solution, knowing the pathlength d_λ , the intensity of the incident light $I_{0,\lambda}$, and the extinction coefficient $\epsilon_{i,\lambda}$ at a particular wavelength λ . In generalized form, the Beer-Lambert law is expressed as:

$$I_\lambda = I_{0,\lambda} e^{-d_\lambda \mu_{a,\lambda}} \tag{1}$$

$$\mu_{a,\lambda} = \sum_{i=1}^n \epsilon_{i,\lambda} \cdot c_i \tag{2}$$

where $\mu_{a,\lambda}$ is the bulk absorption coefficient and represents the probability of absorption per unit length. The minimum number of discrete wavelengths that are required to solve EQS. 1-2 are the number of significant absorbers that are present in the solution.

[0005] A practical application of this technique is pulse oximetry, which utilizes a noninvasive sensor to measure oxygen saturation (SpO₂) and pulse rate. In general, the sensor has light emitting diodes (LEDs) that transmit optical radiation of red and infrared wavelengths into a tissue site and a detector that responds to the intensity of the optical radiation after absorption (e.g., by transmission or transreflectance) by pulsatile arterial blood flowing within the tissue site. Based on this response, a processor determines measurements for SPO₂, pulse rate, and can output representative plethysmographic waveforms. Thus, “pulse oximetry” as used herein encompasses its broad ordinary meaning known to one of skill in the art, which includes at least those noninvasive procedures for measuring parameters of circulating blood through spectroscopy. Moreover, “plethysmograph” as used herein (commonly referred to as “photoplethysmograph”), encompasses its broad ordinary meaning known to one of skill in the art, which includes at least data representative of a change in the absorption of particular wavelengths of light as a function of the changes in body tissue resulting from pulsing blood. Pulse oximeters capable of reading through motion induced noise are available from Masimo Corporation (“Masimo”) of Irvine, Calif. Moreover, portable and other oximeters capable of reading through motion induced noise are disclosed in at least U.S. Pat. Nos. 6,770,028, 6,658,276, 6,157,850, 6,002,952 5,769,785, and 5,758,644, which are owned by Masimo and are incorporated by reference herein. Such reading through motion oximeters have gained rapid acceptance in a wide variety of medical applications, including surgical wards, intensive care and neonatal units, general wards, home care, physical training, and virtually all types of monitoring scenarios.

SUMMARY OF THE INVENTION

[0006] There is a need to noninvasively measure multiple physiological parameters, other than, or in addition to, oxygen saturation and pulse rate. For example, hemoglobin species that are also significant under certain circumstances are carboxyhemoglobin and methemoglobin. Other blood parameters that may be measured to provide important clinical information are fractional oxygen saturation, total hemaglobin (Hbt), bilirubin and blood glucose, to name a few.

[0007] One aspect of a physiological sensor is light emitting sources, each activated by addressing at least one row and at least one column of an electrical grid. The light emitting sources transmit light having multiple wavelengths and a detector is responsive to the transmitted light after attenuation by body tissue.

[0008] Another aspect of a physiological sensor is light emitting sources capable of transmitting light having multiple wavelengths. Each of the light emitting sources includes a first contact and a second contact. The first contacts of a first set of the light emitting sources are in communication with a first conductor and the second contacts of a second set of the light emitting sources are in communication with a second conductor. A detector is capable of detecting the transmitted light attenuated by body tissue and outputting a signal indicative of at least one physiological parameter of the body tissue. At least one light emitting source of the first set and at least one light emitting source of the second set are not common to the first and second sets. Further, each of the first set and the second set comprises at least two of the light emitting sources.

[0009] A further aspect of a physiological sensor sequentially addresses light emitting sources using conductors of an electrical grid so as to emit light having multiple wavelengths that when attenuated by body tissue is indicative of at least one physiological characteristic. The emitted light is detected after attenuation by body tissue.

BRIEF DESCRIPTION OF THE DRAWINGS

- [0010] **FIG. 1** is a perspective view of a physiological measurement system utilizing a multiple wavelength sensor;
- [0011] **FIGS. 2A-C** are perspective views of multiple wavelength sensor embodiments;
- [0012] **FIG. 3** is a general block diagram of a multiple wavelength sensor and sensor controller;
- [0013] **FIG. 4** is an exploded perspective view of a multiple wavelength sensor embodiment;
- [0014] **FIG. 5** is a general block diagram of an emitter assembly;
- [0015] **FIG. 6** is a perspective view of an emitter assembly embodiment;
- [0016] **FIG. 7** is a general block diagram of an emitter array;
- [0017] **FIG. 8** is a schematic diagram of an emitter array embodiment;
- [0018] **FIG. 9** is a general block diagram of equalization;
- [0019] **FIGS. 10A-D** are block diagrams of various equalization embodiments;
- [0020] **FIGS. 11A-C** are perspective views of an emitter assembly incorporating various equalization embodiments;
- [0021] **FIG. 12** is a general block diagram of an emitter substrate;
- [0022] **FIGS. 13-14** are top and detailed side views of an emitter substrate embodiment;
- [0023] **FIGS. 15-16** are top and bottom component layout views of an emitter substrate embodiment;
- [0024] **FIG. 17** is a schematic diagram of an emitter substrate embodiment;
- [0025] **FIG. 18** is a plan view of an inner layer of an emitter substrate embodiment;
- [0026] **FIG. 19** is a general block diagram of an interconnect assembly in relationship to other sensor assemblies;
- [0027] **FIG. 20** is a block diagram of an interconnect assembly embodiment;
- [0028] **FIG. 21** is a partially-exploded perspective view of a flex circuit assembly embodiment of an interconnect assembly;
- [0029] **FIG. 22** is a top plan view of a flex circuit;
- [0030] **FIG. 23** is an exploded perspective view of an emitter portion of a flex circuit assembly;
- [0031] **FIG. 24** is an exploded perspective view of a detector assembly embodiment;
- [0032] **FIGS. 25-26** are block diagrams of adjacent detector and stacked detector embodiments;
- [0033] **FIG. 27** is a block diagram of a finger clip embodiment of an attachment assembly;
- [0034] **FIG. 28** is a general block diagram of a detector pad;
- [0035] **FIGS. 29A-B** are perspective views of detector pad embodiments;
- [0036] **FIGS. 30A-H** are perspective bottom, perspective top, bottom, back, top, side cross sectional, side, and front cross sectional views of an emitter pad embodiment;
- [0037] **FIGS. 31A-H** are perspective bottom, perspective top, top, back, bottom, side cross sectional, side, and front cross sectional views of a detector pad embodiment;
- [0038] **FIGS. 32A-H** are perspective bottom, perspective top, top, back, bottom, side cross sectional, side, and front cross sectional views of a shoe box;
- [0039] **FIGS. 33A-H** are perspective bottom, perspective top, top, back, bottom, side cross sectional, side, and front cross sectional views of a slim-finger emitter pad embodiment;
- [0040] **FIGS. 34A-H** are perspective bottom, perspective top, top, back, bottom, side cross sectional, side, and front cross sectional views of a slim-finger detector pad embodiment;
- [0041] **FIGS. 35A-B** are plan and cross sectional views, respectively, of a spring assembly embodiment;
- [0042] **FIGS. 36A-C** are top, perspective and side views of a finger clip spring;
- [0043] **FIGS. 37A-D** are top, back, bottom, and side views of a spring plate;
- [0044] **FIGS. 38A-D** are front cross sectional, bottom, front and side cross sectional views of an emitter-pad shell;
- [0045] **FIGS. 39A-D** are back, top, front and side cross sectional views of a detector-pad shell;
- [0046] **FIG. 40** is a general block diagram of a monitor and a sensor;
- [0047] **FIGS. 41A-C** are schematic diagrams of grid drive embodiments for a sensor having back-to-back diodes and an information element;

[0048] FIGS. 42 is a schematic diagrams of a grid drive embodiment for an information element;

[0049] FIGS. 43A-C are schematic diagrams for grid drive readable information elements;

[0050] FIGS. 44A-B are cross sectional and side cut away views of a sensor cable;

[0051] FIG. 45 is a block diagram of a sensor controller embodiment; and

[0052] FIG. 46 is a detailed exploded perspective view of a multiple wavelength sensor embodiment.

DETAILED DESCRIPTION OF THE PREFERRED EMBODIMENTS

Overview

[0053] In this application, reference is made to many blood parameters. Some references that have common shorthand designations are referenced through such shorthand designations. For example, as used herein, HbCO designates carboxyhemoglobin, HbMet designates methemoglobin, and Hbt designates total hemoglobin. Other shorthand designations such as COHb, MetHb, and tHb are also common in the art for these same constituents. These constituents are generally reported in terms of a percentage, often referred to as saturation, relative concentration or fractional saturation. Total hemoglobin is generally reported as a concentration in g/dL. The use of the particular shorthand designators presented in this application does not restrict the term to any particular manner in which the designated constituent is reported.

[0054] FIG. 1 illustrates a physiological measurement system 10 having a monitor 100 and a multiple wavelength sensor assembly 200 with enhanced measurement capabilities as compared with conventional pulse oximetry. The physiological measurement system 10 allows the monitoring of a person, including a patient. In particular, the multiple wavelength sensor assembly 200 allows the measurement of blood constituent and related parameters in addition to oxygen saturation and pulse rate. Alternatively, the multiple wavelength sensor assembly 200 allows the measurement of oxygen saturation and pulse rate with increased accuracy or robustness as compared with conventional pulse oximetry.

[0055] In one embodiment, the sensor assembly 200 is configured to plug into a monitor sensor port 110. Monitor keys 160 provide control over operating modes and alarms, to name a few. A display 170 provides readouts of measured parameters, such as oxygen saturation, pulse rate, HbCO and HbMet to name a few.

[0056] FIGS. 2A illustrates a multiple wavelength sensor assembly 200 having a sensor 400 adapted to attach to a tissue site, a sensor cable 4400 and a monitor connector 210. In one embodiment, the sensor 400 is incorporated into a reusable finger clip adapted to removably attach to, and transmit light through, a fingertip. The sensor cable 4400 and monitor connector 210 are integral to the sensor 400, as shown. In alternative embodiments, the sensor 400 may be configured separately from the cable 4400 and connector 210.

[0057] FIGS. 2B-C illustrate alternative sensor embodiments, including a sensor 401 (FIG. 2B) partially disposable

and partially reusable (resposable) and utilizing an adhesive attachment mechanism. Also shown is a sensor 402 (FIG. 2C) being disposable and utilizing an adhesive attachment mechanism. In other embodiments, a sensor may be configured to attach to various tissue sites other than a finger, such as a foot or an ear. Also a sensor may be configured as a reflectance or transreflectance device that attaches to a forehead or other tissue surface.

[0058] FIG. 3 illustrates a sensor assembly 400 having an emitter assembly 500, a detector assembly 2400, an interconnect assembly 1900 and an attachment assembly 2700. The emitter assembly 500 responds to drive signals received from a sensor controller 4500 in the monitor 100 via the cable 4400 so as to transmit optical radiation having a plurality of wavelengths into a tissue site. The detector assembly 2400 provides a sensor signal to the monitor 100 via the cable 4400 in response to optical radiation received after attenuation by the tissue site. The interconnect assembly 1900 provides electrical communication between the cable 4400 and both the emitter assembly 500 and the detector assembly 2400. The attachment assembly 2700 attaches the emitter assembly 500 and detector assembly 2400 to a tissue site, as described above. The emitter assembly 500 is described in further detail with respect to FIG. 5, below. The interconnect assembly 1900 is described in further detail with respect to FIG. 19, below. The detector assembly 2400 is described in further detail with respect to FIG. 24, below. The attachment assembly 2700 is described in further detail with respect to FIG. 27, below.

[0059] FIG. 4 illustrates a sensor 400 embodiment that removably attaches to a fingertip. The sensor 400 houses a multiple wavelength emitter assembly 500 and corresponding detector assembly 2400. A flex circuit assembly 1900 mounts the emitter and detector assemblies 500, 2400 and interconnects them to a multi-wire sensor cable 4400. Advantageously, the sensor 400 is configured in several respects for both wearer comfort and parameter measurement performance. The flex circuit assembly 1900 is configured to mechanically decouple the cable 4400 wires from the emitter and detector assemblies 500, 2400 to reduce pad stiffness and wearer discomfort. The pads 3000, 3100 are mechanically decoupled from shells 3800, 3900 to increase flexibility and wearer comfort. A spring 3600 is configured in hinged shells 3800, 3900 so that the pivot point of the finger clip is well behind the fingertip, improving finger attachment and more evenly distributing the clip pressure along the finger.

[0060] As shown in FIG. 4, the detector pad 3100 is structured to properly position a fingertip in relationship to the detector assembly 2400. The pads have flaps that block ambient light. The detector assembly 2400 is housed in an enclosure so as to reduce light piping from the emitter assembly to the detector assembly without passing through fingertip tissue. These and other features are described in detail below. Specifically, emitter assembly embodiments are described with respect to FIGS. 5-18. Interconnect assembly embodiments, including the flexible circuit assembly 1900, are described with respect to FIGS. 19-23. Detector assembly embodiments are described with respect to FIGS. 24-26. Attachment assembly embodiments are described with respect to FIGS. 27-39.

Emitter Assembly

[0061] FIG. 5 illustrates an emitter assembly 500 having an emitter array 700, a substrate 1200 and equalization 900. The emitter array 700 has multiple light emitting sources, each activated by addressing at least one row and at least one column of an electrical grid. The light emitting sources are capable of transmitting optical radiation having multiple wavelengths. The equalization 900 accounts for differences in tissue attenuation of the optical radiation across the multiple wavelengths so as to at least reduce wavelength-dependent variations in detected intensity. The substrate 1200 provides a physical mount for the emitter array and emitter-related equalization and a connection between the emitter array and the interconnection assembly. Advantageously, the substrate 1200 also provides a bulk temperature measurement so as to calculate the operating wavelengths for the light emitting sources. The emitter array 700 is described in further detail with respect to FIG. 7, below. Equalization is described in further detail with respect to FIG. 9, below. The substrate 1200 is described in further detail with respect to FIG. 12, below.

[0062] FIG. 6 illustrates an emitter assembly 500 embodiment having an emitter array 700, an encapsulant 600, an optical filter 1100 and a substrate 1200. Various aspects of the emitter assembly 500 are described with respect to FIGS. 7-18, below. The emitter array 700 emits optical radiation having multiple wavelengths of predetermined nominal values, advantageously allowing multiple parameter measurements. In particular, the emitter array 700 has multiple light emitting diodes (LEDs) 710 that are physically arranged and electrically connected in an electrical grid to facilitate drive control, equalization, and minimization of optical pathlength differences at particular wavelengths. The optical filter 1100 is advantageously configured to provide intensity equalization across a specific LED subset. The substrate 1200 is configured to provide a bulk temperature of the emitter array 700 so as to better determine LED operating wavelengths.

[0063] Emitter Array

[0064] FIG. 7 illustrates an emitter array 700 having multiple light emitters (LE) 710 capable of emitting light 702 having multiple wavelengths into a tissue site 1. Row drivers 4530 and column drivers 4560 are electrically connected to the light emitters 710 and activate one or more light emitters 710 by addressing at least one row 720 and at least one column 740 of an electrical grid. In one embodiment, the light emitters 710 each include a first contact 712 and a second contact 714. The first contact 712 of a first subset 730 of light emitters is in communication with a first conductor 720 of the electrical grid. The second contact 714 of a second subset 750 of light emitters is in communication with a second conductor 740. Each subset comprises at least two light emitters, and at least one of the light emitters of the first and second subsets 730, 750 are not in common. A detector 2400 is capable of detecting the emitted light 702 and outputting a sensor signal 2500 responsive to the emitted light 702 after attenuation by the tissue site 1. As such, the sensor signal 2500 is indicative of at least one physiological parameter corresponding to the tissue site 1, as described above.

[0065] FIG. 8 illustrates an emitter array 700 having LEDs 801 connected within an electrical grid of n rows and

m columns totaling n+m drive lines 4501, 4502, where n and m integers greater than one. The electrical grid advantageously minimizes the number of drive lines required to activate the LEDs 801 while preserving flexibility to selectively activate individual LEDs 801 in any sequence and multiple LEDs 801 simultaneously. The electrical grid also facilitates setting LED currents so as to control intensity at each wavelength, determining operating wavelengths and monitoring total grid current so as to limit power dissipation. The emitter array 700 is also physically configured in rows 810. This physical organization facilitates clustering LEDs 801 according to wavelength so as to minimize pathlength variations and facilitates equalization of LED intensities.

[0066] As shown in FIG. 8, one embodiment of an emitter array 700 comprises up to sixteen LEDs 801 configured in an electrical grid of four rows 810 and four columns 820. Each of the four row drive lines 4501 provide a common anode connection to four LEDs 801, and each of the four column drive lines 4502 provide a common cathode connection to four LEDs 801. Thus, the sixteen LEDs 801 are advantageously driven with only eight wires, including four anode drive lines 812 and four cathode drive lines 822. This compares favorably to conventional common anode or cathode LED configurations, which require more drive lines. In a particular embodiment, the emitter array 700 is partially populated with eight LEDs having nominal wavelengths as shown in TABLE 1. Further, LEDs having wavelengths in the range of 610-630 nm are grouped together in the same row. The emitter array 700 is adapted to a physiological measurement system 10 (FIG. 1) for measuring H_bCO and/or METHb in addition to S_pO₂ and pulse rate.

TABLE 1

LED	Nominal LED Wavelengths		
	λ	Row	Col
D1	630	1	1
D2	620	1	2
D3	610	1	3
D4		1	4
D5	700	2	1
D6	730	2	2
D7	660	2	3
D8	805	2	4
D9		3	1
D10		3	2
D11		3	3
D12	905	3	4
D13		4	1
D14		4	2
D15		4	3
D16		4	4

[0067] Also shown in FIG. 8, row drivers 4530 and column drivers 4560 located in the monitor 100 selectively activate the LEDs 801. In particular, row and column drivers 4530, 4560 function together as switches to V_{cc} and current sinks, respectively, to activate LEDs and as switches to ground and V_{cc}, respectively, to deactivate LEDs. This push-pull drive configuration advantageously prevents parasitic current flow in deactivated LEDs. In a particular embodiment, only one row drive line 4501 is switched to V_{cc} at a time. One to four column drive lines 4502, however, can be simultaneously switched to a current sink so as to simultaneously activate multiple LEDs within a particular

row. Activation of two or more LEDs of the same wavelength facilitates intensity equalization, as described with respect to FIGS. 9-11, below. LED drivers are described in further detail with respect to FIG. 45, below.

[0068] Although an emitter assembly is described above with respect to an array of light emitters each configured to transmit optical radiation centered around a nominal wavelength, in another embodiment, an emitter assembly advantageously utilizes one or more tunable broadband light sources, including the use of filters to select the wavelength, so as to minimize wavelength-dependent pathlength differences from emitter to detector. In yet another emitter assembly embodiment, optical radiation from multiple emitters each configured to transmit optical radiation centered around a nominal wavelength is funneled to a tissue site point so as to minimize wavelength-dependent pathlength differences. This funneling may be accomplished with fiber optics or mirrors, for example. In further embodiments, the LEDs 801 can be configured with alternative orientations with correspondingly different drivers among various other configurations of LEDs, drivers and interconnecting conductors.

[0069] Equalization

[0070] FIG. 9 illustrate a physiological parameter measurement system 10 having a controller 4500, an emitter assembly 500, a detector assembly 2400 and a front-end 4030. The emitter assembly 500 is configured to transmit optical radiation having multiple wavelengths into the tissue site 1. The detector assembly 2400 is configured to generate a sensor signal 2500 responsive to the optical radiation after tissue attenuation. The front-end 4030 conditions the sensor signal 2500 prior to analog-to-digital conversion (ADC).

[0071] FIG. 9 also generally illustrates equalization 900 in a physiological measurement system 10 operating on a tissue site 1. Equalization encompasses features incorporated into the system 10 in order to provide a sensor signal 2500 that falls well within the dynamic range of the ADC across the entire spectrum of emitter wavelengths. In particular, equalization compensates for the imbalance in tissue light absorption due to Hb and HbO₂ 910. Specifically, these blood constituents attenuate red wavelengths greater than IR wavelengths. Ideally, equalization 900 balances this unequal attenuation. Equalization 900 can be introduced anywhere in the system 10 from the controller 4500 to front-end 4000 and can include compensatory attenuation versus wavelength, as shown, or compensatory amplification versus or both.

[0072] Equalization can be achieved to a limited extent by adjusting drive currents from the controller 4500 and front-end 4030 amplification accordingly to wavelength so as to compensate for tissue absorption characteristics. Signal demodulation constraints, however, limit the magnitude of these adjustments. Advantageously, equalization 900 is also provided along the optical path from emitters 500 to detector 2400. Equalization embodiments are described in further detail with respect to FIGS. 10-11, below.

[0073] FIGS. 10A-D illustrate various equalization embodiments having an emitter array 700 adapted to transmit optical radiation into a tissue site 1 and a detector assembly 2400 adapted to generate a sensor signal 2500 responsive to the optical radiation after tissue attenuation. FIG. 10A illustrates an optical filter 1100 that attenuates at least a portion of the optical radiation before it is transmitted

into a tissue site 1. In particular, the optical filter 1100 attenuates at least a portion of the IR wavelength spectrum of the optical radiation so as to approximate an equalization curve 900 (FIG. 9). FIG. 10B illustrates an optical filter 1100 that attenuates at least a portion of the optical radiation after it is attenuated by a tissue site 1, where the optical filter 1100 approximates an equalization curve 900 (FIG. 9).

[0074] FIG. 10C illustrates an emitter array 700 where at least a portion of the emitter array generates one or more wavelengths from multiple light emitters 710 of the same wavelength. In particular, the same-wavelength light emitters 710 boost at least a portion of the red wavelength spectrum so as to approximately equalize the attenuation curves 910 (FIG. 9). FIG. 10D illustrates a detector assembly 2400 having multiple detectors 2610, 2620 selected so as to equalize the attenuation curves 910 (FIG. 9). To a limited extent, optical equalization can also be achieved by selection of particular emitter array 700 and detector 2400 components, e.g. LEDs having higher output intensities or detectors having higher sensitivities at red wavelengths. Although equalization embodiments are described above with respect to red and IR wavelengths, these equalization embodiments can be applied to equalize tissue characteristics across any portion of the optical spectrum.

[0075] FIGS. 11A-C illustrates an optical filter 1100 for an emitter assembly 500 that advantageously provides optical equalization, as described above. LEDs within the emitter array 700 may be grouped according to output intensity or wavelength or both. Such a grouping facilitates equalization of LED intensity across the array. In particular, relatively low tissue absorption and/or relatively high output intensity LEDs can be grouped together under a relatively high attenuation optical filter. Likewise, relatively low tissue absorption and/or relatively low output intensity LEDs can be grouped together without an optical filter or under a relatively low or negligible attenuation optical filter. Further, high tissue absorption and/or low intensity LEDs can be grouped within the same row with one or more LEDs of the same wavelength being simultaneously activated, as described with respect to FIG. 10C, above. In general, there can be any number of LED groups and any number of LEDs within a group. There can also be any number of optical filters corresponding to the groups having a range of attenuation, including no optical filter and/or a "clear" filter having negligible attenuation.

[0076] As shown in FIGS. 11A-C, a filtering media may be advantageously added to an encapsulant that functions both as a cover to protect LEDs and bonding wires and as an optical filter 1100. In one embodiment, a filtering media 1100 encapsulates a select group of LEDs and a clear media 600 (FIG. 6) encapsulates the entire array 700 and the filtering media 1000 (FIG. 6). In a particular embodiment, corresponding to TABLE 1, above, five LEDs nominally emitting at 660-905 nm are encapsulated with both a filtering media 1100 and an overlying clear media 600 (FIG. 6), i.e. attenuated. In a particular embodiment, the filtering media 1100 is a 40:1 mixture of a clear encapsulant (EPO-TEK OG147-7) and an opaque encapsulate (EPO-TEK OG147) both available from Epoxy Technology, Inc., Billerica, Mass. Three LEDs nominally emitting at 610-630 nm are only encapsulated with the clear media 600 (FIG. 6), i.e. unattenuated. In alternative embodiments, individual LEDs may be singly or multiply encapsulated according to tissue

absorption and/or output intensity. In other alternative embodiments, filtering media may be separately attachable optical filters or a combination of encapsulants and separately attachable optical filters. In a particular embodiment, the emitter assembly 500 has one or more notches along each side proximate the component end 1305 (FIG. 13) for retaining one or more clip-on optical filters.

[0077] Substrate

[0078] FIG. 12 illustrates light emitters 710 configured to transmit optical radiation 1201 having multiple wavelengths in response to corresponding drive currents 1210. A thermal mass 1220 is disposed proximate the emitters 710 so as to stabilize a bulk temperature 1202 for the emitters. A temperature sensor 1230 is thermally coupled to the thermal mass 1220, wherein the temperature sensor 1230 provides a temperature sensor output 1232 responsive to the bulk temperature 1202 so that the wavelengths are determinable as a function of the drive currents 1210 and the bulk temperature 1202.

[0079] In one embodiment, an operating wavelength λ_a of each light emitter 710 is determined according to EQ. 3

$$\lambda_a = f(T_b, I_{drive}, \sum I_{drive}) \quad (3)$$

where T_b is the bulk temperature, I_{drive} is the drive current for a particular light emitter, as determined by the sensor controller 4500 (FIG. 45), described below, and $\sum I_{drive}$ is the total drive current for all light emitters. In another embodiment, temperature sensors are configured to measure the temperature of each light emitter 710 and an operating wavelength λ_a of each light emitter 710 is determined according to EQ. 4

$$\lambda_a = f(T_a, I_{drive}, \sum I_{drive}) \quad (4)$$

where T_a is the temperature of a particular light emitter, I_{drive} is the drive current for that light emitter and $\sum I_{drive}$ is the total drive current for all light emitters.

[0080] In yet another embodiment, an operating wavelength for each light emitter is determined by measuring the junction voltage for each light emitter 710. In a further embodiment, the temperature of each light emitter 710 is controlled, such as by one or more Peltier cells coupled to each light emitter 710, and an operating wavelength for each light emitter 710 is determined as a function of the resulting controlled temperature or temperatures. In other embodiments, the operating wavelength for each light emitter 710 is determined directly, for example by attaching a charge coupled device (CCD) to each light emitter or by attaching a fiberoptic to each light emitter and coupling the fiberoptics to a wavelength measuring device, to name a few.

[0081] FIGS. 13-18 illustrate one embodiment of a substrate 1200 configured to provide thermal conductivity between an emitter array 700 (FIG. 8) and a thermistor 1540 (FIG. 16). In this manner, the resistance of the thermistor 1540 (FIG. 16) can be measured in order to determine the bulk temperature of LEDs 801 (FIG. 8) mounted on the

substrate 1200. The substrate 1200 is also configured with a relatively significant thermal mass, which stabilizes and normalizes the bulk temperature so that the thermistor measurement of bulk temperature is meaningful.

[0082] FIGS. 13-14 illustrate a substrate 1200 having a component side 1301, a solder side 1302, a component end 1305 and a connector end 1306. Alignment notches 1310 are disposed between the ends 1305, 1306. The substrate 1200 further has a component layer 1401, inner layers 1402-1405 and a solder layer 1406. The inner layers 1402-1405, e.g. inner layer 1402 (FIG. 18), have substantial metallized areas 1411 that provide a thermal mass 1220 (FIG. 12) to stabilize a bulk temperature for the emitter array 700 (FIG. 12). The metallized areas 1411 also function to interconnect component pads 1510 and wire bond pads 1520 (FIG. 15) to the connector 1530.

[0083] FIGS. 15-16 illustrate a substrate 1200 having component pads 1510 and wire bond pads 1520 at a component end 1305. The component pads 1510 mount and electrically connect a first side (anode or cathode) of the LEDs 801 (FIG. 8) to the substrate 1200. Wire bond pads 1520 electrically connect a second side (cathode or anode) of the LEDs 801 (FIG. 8) to the substrate 1200. The connector end 1306 has a connector 1530 with connector pads 1532, 1534 that mount and electrically connect the emitter assembly 500 (FIG. 23), including the substrate 1200, to the flex circuit 2200 (FIG. 22). Substrate layers 1401-1406 (FIG. 14) have traces that electrically connect the component pads 1510 and wire bond pads 1520 to the connector 1532-1534. A thermistor 1540 is mounted to thermistor pads 1550 at the component end 1305, which are also electrically connected with traces to the connector 1530. Plated thru holes electrically connect the connector pads 1532, 1534 on the component and solder sides 1301, 1302, respectively.

[0084] FIG. 17 illustrates the electrical layout of a substrate 1200. A portion of the LEDs 801, including D1-D4 and D13-D16 have cathodes physically and electrically connected to component pads 1510 (FIG. 15) and corresponding anodes wire bonded to wire bond pads 1520. Another portion of the LEDs 801, including D5-D8 and D9-D12, have anodes physically and electrically connected to component pads 1510 (FIG. 15) and corresponding cathodes wire bonded to wire bond pads 1520. The connector 1530 has row pinouts J21-J24, column pinouts J31-J34 and thermistor pinouts J40-J41 for the LEDs 801 and thermistor 1540.

[0085] Interconnect Assembly

[0086] FIG. 19 illustrates an interconnect assembly 1900 that mounts the emitter assembly 500 and detector assembly 2400, connects to the sensor cable 4400 and provides electrical communications between the cable and each of the emitter assembly 500 and detector assembly 2400. In one embodiment, the interconnect assembly 1900 is incorporated with the attachment assembly 2700, which holds the emitter and detector assemblies to a tissue site. An interconnect assembly embodiment utilizing a flexible (flex) circuit is described with respect to FIGS. 20-24, below.

[0087] FIG. 20 illustrates an interconnect assembly 1900 embodiment having a circuit substrate 2200, an emitter mount 2210, a detector mount 2220 and a cable connector

2230. The emitter mount **2210**, detector mount **2220** and cable connector **2230** are disposed on the circuit substrate **2200**. The emitter mount **2210** is adapted to mount an emitter assembly **500** having multiple emitters. The detector mount **2220** is adapted to mount a detector assembly **2400** having a detector. The cable connector **2230** is adapted to attach a sensor cable **4400**. A first plurality of conductors **2040** disposed on the circuit substrate **2200** electrically interconnects the emitter mount **2210** and the cable connector **2230**. A second plurality of conductors **2050** disposed on the circuit substrate **2200** electrically interconnects the detector mount **2220** and the cable connector **2230**. A decoupling **2060** disposed proximate the cable connector **2230** substantially mechanically isolates the cable connector **2230** from both the emitter mount **2210** and the detector mount **2220** so that sensor cable stiffness is not translated to the emitter assembly **500** or the detector assembly **2400**. A shield **2070** is adapted to fold over and shield one or more wires or pairs of wires of the sensor cable **4400**.

[0088] **FIG. 21** illustrates a flex circuit assembly **1900** having a flex circuit **2200**, an emitter assembly **500** and a detector assembly **2400**, which is configured to terminate the sensor end of a sensor cable **4400**. The flex circuit assembly **1900** advantageously provides a structure that electrically connects yet mechanically isolates the sensor cable **4400**, the emitter assembly **500** and the detector assembly **2400**. As a result, the mechanical stiffness of the sensor cable **4400** is not translated to the sensor pads **3000**, **3100** (**FIGS. 30-31**), allowing a comfortable finger attachment for the sensor **200** (**FIG. 1**). In particular, the emitter assembly **500** and detector assembly **2400** are mounted to opposite ends **2201**, **2202** (**FIG. 22**) of an elongated flex circuit **2200**. The sensor cable **4400** is mounted to a cable connector **2230** extending from a middle portion of the flex circuit **2200**. Detector wires **4470** are shielded at the flex circuit junction by a fold-over conductive ink flap **2240**, which is connected to a cable inner shield **4450**. The flex circuit **2200** is described in further detail with respect to **FIG. 22**. The emitter portion of the flex circuit assembly **1900** is described in further detail with respect to **FIG. 23**. The detector assembly **2400** is described with respect to **FIG. 24**. The sensor cable **4400** is described with respect to **FIGS. 44A-B**, below.

[0089] **FIG. 22** illustrates a sensor flex circuit **2200** having an emitter end **2201**, a detector end **2202**, an elongated interconnect **2204**, **2206** between the ends **2201**, **2202** and a cable connector **2230** extending from the interconnect **2204**, **2206**. The emitter end **2201** forms a “head” having emitter solder pads **2210** for attaching the emitter assembly **500** (**FIG. 6**) and mounting ears **2214** for attaching to the emitter pad **3000** (**FIG. 30B**), as described below. The detector end **2202** has detector solder pads for attaching the detector **2410** (**FIG. 24**). The interconnect **2204** between the emitter end **2201** and the cable connector **2230** forms a “neck,” and the interconnect **2206** between the detector end **2202** and the cable connector **2230** forms a “tail.” The cable connector **2230** forms “wings” that extend from the interconnect **2204**, **2206** between the neck **2204** and tail **2206**. A conductive ink flap **2240** connects to the cable inner shield **4450** (**FIGS. 44A-B**) and folds over to shield the detector wires **4470** (**FIGS. 44A-B**) soldered to the detector wire pads **2236**. The outer wire pads **2238** connect to the remaining cable wires **4430** (**FIGS. 44A-B**). The flex circuit **2200** has top coverlay, top ink, inner coverlay, trace, trace base, bottom ink and bottom coverlay layers.

[0090] The flex circuit **2200** advantageously provides a connection between a multiple wire sensor cable **4400** (**FIGS. 44A-B**), a multiple wavelength emitter assembly **500** (**FIG. 6**) and a detector assembly **2400** (**FIG. 24**) without rendering the emitter and detector assemblies unwieldy and stiff. In particular, the wings **2230** provide a relatively large solder pad area **2232** that is narrowed at the neck **2204** and tail **2206** to mechanically isolate the cable **4400** (**FIGS. 44A-B**) from the remainder of the flex circuit **2200**. Further, the neck **2206** is folded (see **FIG. 4**) for installation in the emitter pad **3000** (**FIGS. 30A-H**) and acts as a flexible spring to further mechanically isolate the cable **4400** (**FIGS. 44A-B**) from the emitter assembly **500** (**FIG. 4**). The tail **2206** provides an integrated connectivity path between the detector assembly **2400** (**FIG. 24**) mounted in the detector pad **3100** (**FIGS. 31A-H**) and the cable connector **2230** mounted in the opposite emitter pad **3000** (**FIGS. 30A-H**).

[0091] **FIG. 23** illustrates the emitter portion of the flex circuit assembly **1900** (**FIG. 21**) having the emitter assembly **500**. The emitter assembly connector **1530** is attached to the emitter end **2210** of the flex circuit **2200** (**FIG. 22**). In particular, reflow solder **2330** connects thru hole pads **1532**, **1534** of the emitter assembly **500** to corresponding emitter pads **2310** of the flex circuit **2200** (**FIG. 22**).

[0092] **FIG. 24** illustrates a detector assembly **2400** including a detector **2410**, solder pads **2420**, copper mesh tape **2430**, an EMI shield **2440** and foil **2450**. The detector **2410** is soldered **2460** chip side down to detector solder pads **2420** of the flex circuit **2200**. The detector solder joint and detector ground pads **2420** are wrapped with the Kapton tape **2470**. EMI shield tabs **2442** are folded onto the detector pads **2420** and soldered. The EMI shield walls are folded around the detector **2410** and the remaining tabs **2442** are soldered to the back of the EMI shield **2440**. The copper mesh tape **2430** is cut to size and the shielded detector and flex circuit solder joint are wrapped with the copper mesh tape **2430**. The foil **2450** is cut to size with a predetermined aperture **2452**. The foil **2450** is wrapped around shielded detector with the foil side in and the aperture **2452** is aligned with the EMI shield grid **2444**.

[0093] Detector Assembly

[0094] **FIG. 25** illustrates an alternative detector assembly **2400** embodiment having adjacent detectors. Optical radiation having multiple wavelengths generated by emitters **700** is transmitted into a tissue site **1**. Optical radiation at a first set of wavelengths is detected by a first detector **2510**, such as, for example, a Si detector. Optical radiation at a second set of wavelengths is detected by a second detector **2520**, such as, for example, a GaAs detector.

[0095] **FIG. 26** illustrates another alternative detector assembly **2400** embodiment having stacked detectors coaxial along a light path. Optical radiation having multiple wavelengths generated by emitters **700** is transmitted into a tissue site **1**. Optical radiation at a first set of wavelengths is detected by a first detector **2610**. Optical radiation at a second set of wavelengths passes through the first detector **2610** and is detected by a second detector **2620**. In a particular embodiment, a silicon (Si) detector and a gallium arsenide (GaAs) detector are used. The Si detector is placed on top of the GaAs detector so that light must pass through the Si detector before reaching the GaAs detector. The Si detector can be placed directly on top of the GaAs detector

or the Si and GaAs detector can be separated by some other medium, such as a transparent medium or air. In another particular embodiment, a germanium detector is used instead of the GaAs detector. Advantageously, the stacked detector arrangement minimizes error caused by pathlength differences as compared with the adjacent detector embodiment.

[0096] Finger Clip

[0097] FIG. 27 illustrates a finger clip embodiment 2700 of a physiological sensor attachment assembly. The finger clip 2700 is configured to removably attach an emitter assembly 500 (FIG. 6) and detector assembly 2400 (FIG. 24), interconnected by a flex circuit assembly 1900, to a fingertip. The finger clip 2700 has an emitter shell 3800, an emitter pad 3000, a detector pad 2800 and a detector shell 3900. The emitter shell 3800 and the detector shell 3900 are rotatably connected and urged together by the spring assembly 3500. The emitter pad 3000 is fixedly retained by the emitter shell. The emitter assembly 500 (FIG. 6) is mounted proximate the emitter pad 3000 and adapted to transmit optical radiation having a plurality of wavelengths into fingertip tissue. The detector pad 2800 is fixedly retained by the detector shell 3900. The detector assembly 3500 is mounted proximate the detector pad 2800 and adapted to receive the optical radiation after attenuation by fingertip tissue.

[0098] FIG. 28 illustrates a detector pad 2800 advantageously configured to position and comfortably maintain a fingertip relative to a detector assembly for accurate sensor measurements. In particular, the detector pad has fingertip positioning features including a guide 2810, a contour 2820 and a stop 2830. The guide 2810 is raised from the pad surface 2803 and narrows as the guide 2810 extends from a first end 2801 to a second end 2802 so as to increasingly conform to a fingertip as a fingertip is inserted along the pad surface 2803 from the first end 2801. The contour 2820 has an indentation defined along the pad surface 2803 generally shaped to conform to a fingertip positioned over a detector aperture 2840 located within the contour 2820. The stop 2830 is raised from the pad surface 2803 so as to block the end of a finger from inserting beyond the second end 2802. FIGS. 29A-B illustrate detector pad embodiments 3100, 3400 each having a guide 2810, a contour 2820 and a stop 2830, described in further detail with respect to FIGS. 31 and 34, respectively.

[0099] FIGS. 30A-H illustrate an emitter pad 3000 having emitter pad flaps 3010, an emitter window 3020, mounting pins 3030, an emitter assembly cavity 3040, isolation notches 3050, a flex circuit notch 3070 and a cable notch 3080. The emitter pad flaps 3010 overlap with detector pad flaps 3110 (FIGS. 31A-H) to block ambient light. The emitter window 3020 provides an optical path from the emitter array 700 (FIG. 8) to a tissue site. The mounting pins 3030 accommodate apertures in the flex circuit mounting ears 2214 (FIG. 22), and the cavity 3040 accommodates the emitter assembly 500 (FIG. 21). Isolation notches 3050 mechanically decouple the shell attachment 3060 from the remainder of the emitter pad 3000. The flex circuit notch 3070 accommodates the flex circuit tail 2206 (FIG. 22) routed to the detector pad 3100 (FIGS. 31A-H). The cable notch 3080 accommodates the sensor cable 4400 (FIGS. 44A-B). FIGS. 33A-H illustrate an alternative slim finger emitter pad 3300 embodiment.

[0100] FIGS. 31A-H illustrate a detector pad 3100 having detector pad flaps 3110, a shoe box cavity 3120 and isolation notches 3150. The detector pad flaps 3110 overlap with emitter pad flaps 3010 (FIGS. 30A-H), interleaving to block ambient light. The shoe box cavity 3120 accommodates a shoe box 3200 (FIG. 32A-H) described below. Isolation notches 3150 mechanically decouple the attachment points 3160 from the remainder of the detector pad 3100. FIGS. 34A-H illustrate an alternative slim finger detector pad 3400 embodiment.

[0101] FIGS. 32A-H illustrate a shoe box 3200 that accommodates the detector assembly 2400 (FIG. 24). A detector window 3210 provides an optical path from a tissue site to the detector 2410 (FIG. 24). A flex circuit notch 3220 accommodates the flex circuit tail 2206 (FIG. 22) routed from the emitter pad 3000 (FIGS. 30A-H). In one embodiment, the shoe box 3200 is colored black or other substantially light absorbing color and the emitter pad 3000 and detector pad 3100 are each colored white or other substantially light reflecting color.

[0102] FIGS. 35- 37 illustrate a spring assembly 3500 having a spring 3600 configured to urge together an emitter shell 3800 (FIG. 46) and a detector shell 3900. The detector shell is rotatably connected to the emitter shell. The spring is disposed between the shells 3800, 3900 and adapted to create a pivot point along a finger gripped between the shells that is substantially behind the fingertip. This advantageously allows the shell hinge 3810, 3910 (FIGS. 38-39) to expand so as to distribute finger clip force along the inserted finger, comfortably keeping the fingertip in position over the detector without excessive force.

[0103] As shown in FIGS. 36A-C, the spring 3600 has coils 3610, an emitter shell leg 3620 and a detector shell leg 3630. The emitter shell leg 3620 presses against the emitter shell 3800 (FIGS. 38A-D) proximate a grip 3820 (FIGS. 38A-D). The detector shell legs 3630 extend along the detector shell 3900 (FIGS. 39A-D) to a spring plate 3700 (FIGS. 37A-D) attachment point. The coil 3610 is secured by hinge pins 410 (FIG. 46) and is configured to wind as the finger clip is opened, reducing its diameter and stress accordingly.

[0104] As shown in FIGS. 37A-D the spring plate 3700 has attachment apertures 3710, spring leg slots 3720, and a shelf 3730. The attachment apertures 3710 accept corresponding shell posts 3930 (FIGS. 39A-D) so as to secure the spring plate 3700 to the detector shell 3900 (FIG. 39A-D). Spring legs 3630 (FIG. 36A-C) are slidably anchored to the detector shell 3900 (FIG. 39A-D) by the shelf 3730, advantageously allowing the combination of spring 3600, shells 3800, 3900 and hinges 3810, 3910 to adjust to various finger sizes and shapes.

[0105] FIGS. 38- 39 illustrate the emitter and detector shells 3800, 3900, respectively, having hinges 3810, 3910 and grips 3820, 3920. Hinge apertures 3812, 3912 accept hinge pins 410 (FIG. 46) so as to create a finger clip. The detector shell hinge aperture 3912 is elongated, allowing the hinge to expand to accommodate a finger.

[0106] Monitor And Sensor

[0107] FIG. 40 illustrates a monitor 100 and a corresponding sensor assembly 200, as described generally with respect to FIGS. 1-3, above. The sensor assembly 200 has a sensor

400 and a sensor cable **4400**. The sensor **400** houses an emitter assembly **500** having emitters responsive to drivers within a sensor controller **4500** so as to transmit optical radiation into a tissue site. The sensor **400** also houses a detector assembly **2400** that provides a sensor signal **2500** responsive to the optical radiation after tissue attenuation. The sensor signal **2500** is filtered, amplified, sampled and digitized by the front-end **4030** and input to a DSP (digital signal processor) **4040**, which also commands the sensor controller **4500**. The sensor cable **4400** electrically communicates drive signals from the sensor controller **4500** to the emitter assembly **500** and a sensor signal **2500** from the detector assembly **2400** to the front-end **4030**. The sensor cable **4400** has a monitor connector **210** that plugs into a monitor sensor port **110**.

[0108] In one embodiment, the monitor **100** also has a reader **4020** capable of obtaining information from an information element (IE) in the sensor assembly **200** and transferring that information to the DSP **4040**, to another processor or component within the monitor **100**, or to an external component or device that is at least temporarily in communication with the monitor **100**. In an alternative embodiment, the reader function is incorporated within the DSP **4040**, utilizing one or more of DSP I/O, ADC, DAC features and corresponding processing routines, as examples.

[0109] In one embodiment, the monitor connector **210** houses the information element **4000**, which may be a memory device or other active or passive electrical component. In a particular embodiment, the information element **4000** is an EPROM, or other programmable memory, or an EEPROM, or other reprogrammable memory, or both. In an alternative embodiment, the information element **4000** is housed within the sensor **400**, or an information element **4000** is housed within both the monitor connector **4000** and the sensor **400**. In yet another embodiment, the emitter assembly **500** has an information element **4000**, which is read in response to one or more drive signals from the sensor controller **4500**, as described with respect to FIGS. 41-43, below. In a further embodiment, a memory information element is incorporated into the emitter array **700** (FIG. 8) and has characterization information relating to the LEDs **801** (FIG. 8). In one advantageous embodiment, trend data relating to slowly varying parameters, such as perfusion index, HbCO or METHb, to name a few, are stored in an IE memory device, such as EEPROM.

[0110] Back-To-Back LEDs

[0111] FIGS. 41-43 illustrate alternative sensor embodiments. A sensor controller **4500** configured to activate an emitter array **700** (FIG. 7) arranged in an electrical grid, is described with respect to FIG. 7, above. Advantageously, a sensor controller **4500** so configured is also capable of driving a conventional two-wavelength (red and IR) sensor **4100** having back-to-back LEDs **4110**, **4120** or an information element **4300** or both.

[0112] FIG. 41A illustrates a sensor **4100** having an electrical grid **4130** configured to activate light emitting sources by addressing at least one row conductor and at least one column conductor. A first LED **4110** and a second LED **4120** are configured in a back-to-back arrangement so that a first contact **4152** is connected to a first LED **4110** cathode and a second LED **4120** anode and a second contact **4154** is

connected to a first LED **4110** anode and a second LED **4120** cathode. The first contact **4152** is in communications with a first row conductor **4132** and a first column conductor **4134**. The second contact is in communications with a second row conductor **4136** and a second column conductor **4138**. The first LED **4110** is activated by addressing the first row conductor **4132** and the second column conductor **4138**. The second LED **4120** is activated by addressing the second row conductor **4136** and the first column conductor **4134**.

[0113] FIG. 41 B illustrates a sensor cable **4400** embodiment capable of communicating signals between a monitor **100** and a sensor **4100**. The cable **4400** has a first row input **4132**, a first column input **4134**, a second row input **4136** and a second column input **4138**. A first output **4152** combines the first row input **4132** and the first column input **4134**. A second output **4154** combines a second row input **4136** and second column input **4138**.

[0114] FIG. 41C illustrates a monitor **100** capable of communicating drive signals to a sensor **4100**. The monitor **4400** has a first row signal **4132**, a first column signal **4134**, a second row signal **4136** and a second column signal **4138**. A first output signal **4152** combines the first row signal **4132** and the first column signal **4134**. A second output signal **4154** combines a second row signal **4136** and second column signal **4138**.

[0115] Information Elements

[0116] FIGS. 42- 43 illustrate information element **4200-4300** embodiments in communications with emitter array drivers configured to activate light emitters connected in an electrical grid. The information elements are configured to provide information as DC values, AC values or a combination of DC and AC values in response corresponding DC, AC or combination DC and AC electrical grid drive signals. FIG. 42 illustrates information element embodiment **4200** advantageously driven directly by an electrical grid having rows **710** and columns **720**. In particular, the information element **4200** has a series connected resistor R_2 **4210** and diode **4220** connected between a row line **710** and a column line **720** of an electrical grid. In this manner, the resistor R_2 value can be read in a similar manner that LEDs **810** (FIG. 8) are activated. The diode **4220** is oriented, e.g. anode to row and cathode to column as the LEDs so as to prevent parasitic currents from unwanted activation of LEDs **810** (FIG. 8).

[0117] FIGS. 43A-C illustrate other embodiments where the value of R_1 is read with a DC grid drive current and a corresponding grid output voltage level. In other particular embodiments, the combined values of R_1 , R_2 and C or, alternatively, R_1 , R_2 and L are read with a varying (AC) grid drive currents and a corresponding grid output voltage waveform. As one example, a step in grid drive current is used to determine component values from the time constant of a corresponding rise in grid voltage. As another example, a sinusoidal grid drive current is used to determine component values from the magnitude or phase or both of a corresponding sinusoidal grid voltage. The component values determined by DC or AC electrical grid drive currents can represent sensor types, authorized suppliers or manufacturers, emitter wavelengths among others. Further, a diode D (FIG. 43C) can be used to provide one information element reading R_1 at one drive level or polarity and another

information element reading, combining R_1 and R_2 , at a second drive level or polarity, i.e. when the diode is forward biased.

[0118] Passive information element 4300 embodiments may include any of various combinations of resistors, capacitors or inductors connected in series and parallel, for example. Other information element 4300 embodiments connected to an electrical grid and read utilizing emitter array drivers incorporate other passive components, active components or memory components, alone or in combination, including transistor networks, PROMs, ROMs, EPROMs, EEPROMs, gate arrays and PLAs to name a few.

[0119] Sensor Cable

[0120] FIGS. 44A-B illustrate a sensor cable 4400 having an outer jacket 4410, an outer shield 4420, multiple outer wires 4430, an inner jacket 4440, an inner shield 4450, a conductive polymer 4460 and an inner twisted wire pair 4470. The outer wires 4430 are advantageously configured to compactly carry multiple drive signals to the emitter array 700 (FIG. 7). In one embodiment, there are twelve outer wires 4430 corresponding to four anode drive signals 4501 (FIG. 45), four cathode drive signals 4502 (FIG. 45), two thermistor pinouts 1450 (FIG. 15) and two spares. The inner twisted wire pair 4470 corresponds to the sensor signal 2500 (FIG. 25) and is extruded within the conductive polymer 4460 so as to reduce triboelectric noise. The shields 4420, 4450 and the twisted pair 4470 boost EMI and crosstalk immunity for the sensor signal 2500 (FIG. 25).

[0121] Controller

[0122] FIG. 45 illustrates a sensor controller 4500 located in the monitor 100 (FIG. 1) and configured to provide anode drive signals 4501 and cathode drive signals 4502 to the emitter array 700 (FIG. 7). The DSP (digital signal processor) 4040, which performs signal processing functions for the monitor, also provides commands 4042 to the sensor controller 4500. These commands determine drive signal 4501, 4502 levels and timing. The sensor controller 4500 has a command register 4510, an anode selector 4520, anode drivers 4530, current DACs (digital-to-analog converters) 4540, a current multiplexer 4550, cathode drivers 4560, a current meter 4570 and a current limiter 4580. The command register 4510 provides control signals responsive to the DSP commands 4042. In one embodiment, the command register 4510 is a shift register that loads serial command data 4042 from the DSP 4040 and synchronously sets output bits that select or enable various functions within the sensor controller 4500, as described below.

[0123] As shown in FIG. 45, the anode selector 4520 is responsive to anode select 4516 inputs from the command register 4510 that determine which emitter array row 810 (FIG. 8) is active. Accordingly, the anode selector 4520 sets one of the anode on 4522 outputs to the anode drivers 4530, which pulls up to V_{cc} one of the anode outputs 4501 to the emitter array 700 (FIG. 8).

[0124] Also shown in FIG. 45, the current DACs 4540 are responsive to command register data 4519 that determines the currents through each emitter array column 820 (FIG. 8). In one embodiment, there are four, 12-bit DACs associated with each emitter array column 820 (FIG. 8), sixteen DACs in total. That is, there are four DAC outputs 4542 associated with each emitter array column 820 (FIG. 8) corresponding to the currents associated with each row 810 (FIG. 8) along that column 820 (FIG. 8). In a particular embodiment, all sixteen DACs 4540 are organized as a

single shift register, and the command register 4510 serially clocks DAC data 4519 into the DACs 4540. A current multiplexer 4550 is responsive to cathode on 4518 inputs from the command register 4510 and anode on 4522 inputs from the anode selector 4520 so as to convert the appropriate DAC outputs 4542 to current set 4552 inputs to the cathode drivers 4560. The cathode drivers 4560 are responsive to the current set 4552 inputs to pull down one to four of the cathode outputs 4502 to the emitter array 700 (FIG. 8).

[0125] The current meter 4570 outputs a current measure 4572 that indicates the total LED current driving the emitter array 700 (FIG. 8). The current limiter 4580 is responsive to the current measure 4572 and limits specified by the command register 4510 so as to prevent excessive power dissipation by the emitter array 700 (FIG. 8). The current limiter 4580 provides an enable 4582 output to the anode selector 4520. A Hi Limit 4512 input specifies the higher of two preset current limits. The current limiter 4580 latches the enable 4582 output in an off condition when the current limit is exceeded, disabling the anode selector 4520. A trip reset 4514 input resets the enable 4582 output to re-enable the anode selector 4520.

[0126] Sensor Assembly

[0127] As shown in FIG. 46, the sensor 400 has an emitter shell 3800, an emitter pad 3000, a flex circuit assembly 2200, a detector pad 3100 and a detector shell 3900. A sensor cable 4400 attaches to the flex circuit assembly 2200, which includes a flex circuit 2100, an emitter assembly 500 and a detector assembly 2400. The portion of the flex circuit assembly 2200 having the sensor cable 4400 attachment and emitter assembly 500 is housed by the emitter shell 3800 and emitter pad 3000. The portion of the flex circuit assembly 2200 having the detector assembly 2400 is housed by the detector shell 3900 and detector pad 3100. In particular, the detector assembly 2400 inserts into a shoe 3200, and the shoe 3200 inserts into the detector pad 3100. The emitter shell 3800 and detector shell 3900 are fastened by and rotate about hinge pins 410, which insert through coils of a spring 3600. The spring 3600 is held to the detector shell 3900 with a spring plate 3700. A finger stop 450 attaches to the detector shell. In one embodiment, a silicon adhesive 420 is used to attach the pads 3000, 3100 to the shells 3800, 3900, a silicon potting compound 430 is used to secure the emitter and detector assemblies 500, 2400 within the pads 3000, 3100, and a cyanoacrylic adhesive 440 secures the sensor cable 4400 to the emitter shell 3800.

[0128] A multiple wavelength sensor has been disclosed in detail in connection with various embodiments. These embodiments are disclosed by way of examples only and are not to limit the scope of the claims that follow. One of ordinary skill in art will appreciate many variations and modifications.

What is claimed is:

1. A physiological sensor comprising:
 - a plurality of light emitting sources, each light emitting source activated by addressing at least one of a plurality of rows and at least one of a plurality of columns of an electrical grid, the light emitting sources capable of transmitting light of a plurality of wavelengths; and
 - a detector responsive to the transmitted light after attenuation by body tissue.
2. The physiological sensor according to claim 1 wherein multiple ones of the light emitting sources are capable of

transmitting light of the same wavelength, the multiple ones simultaneously activated by addressing one of the rows.

3. The physiological sensor according to claim 2 wherein: the light emitting sources are LEDs, and

each of the LEDs have an anode in common with one of the rows and a cathode in common with one of the columns so that driving one of the rows and one of the columns activates a unique one of the LEDs.

4. The physiological sensor according to claim 3 further comprising:

a plurality of row drivers in communication with the rows; and

a plurality of column drivers in communication with the columns,

wherein a selected row driver sources current to a corresponding row and selected column driver sinks current from a corresponding column so as to activate an addressed one of the LEDs.

5. The physiological sensor according to claim 4 wherein deselected ones of the row drivers pull corresponding rows to a low voltage and deselected ones of the column drivers pull corresponding columns to a high voltage so as to substantially block parasitic current from unaddressed ones of the LEDs.

6. The physiological sensor according to claim 5 wherein the electrical grid comprises at least three rows or at least three columns.

7. The physiological sensor according to claim 5 wherein the electrical grid communicates with at least eight LEDs.

8. The physiological sensor according to claim 5 wherein the electrical grid comprises four rows and four columns in communication with up to sixteen of LEDs.

9. A physiological sensor comprising:

a plurality of light emitting sources capable of transmitting light of a plurality of wavelengths, each including a first contact and a second contact, the first contacts of a first set of the plurality of light emitting sources in communication with a first conductor and the second contacts of a second set of the plurality of light emitting sources in communication with a second conductor; and

a detector capable of detecting the transmitted light attenuated by body tissue and outputting a signal indicative of at least one physiological parameter of the body tissue.

wherein at least one light emitting source of the first set and at least one light emitting source of the second set are not common to the first and second sets, and

wherein each of the first set and the second set comprises at least two of the light emitting sources.

10. The physiological sensor according to claim 9 further comprising:

a plurality of row conductors and a plurality of column conductors of an electrical grid,

wherein the second contacts of the first set are in communication with the column conductors and the first contacts of the second set are in communication with the row conductors so that driving one of the row conductors and one of the column conductors activates one of the light emitting sources.

11. The physiological sensor according to claim 10 wherein:

the electrical grid comprises four row conductors and four column conductors, and

the light emitting sources comprise up to sixteen LEDs.

12. The physiological sensor according to claim 10 wherein a subset of the first set of the light emitting sources are capable of transmitting light having the same wavelength and are capable of being simultaneously activated.

13. The physiological sensor according to claim 9 wherein:

the light emitting sources are LEDs,

the first contacts of the LEDs are anode contacts, and

the second contacts of the LEDs are cathode contacts.

14. The physiological sensor according to claim 13 further comprising:

a first push-pull driver in communications with the first conductor; and

a second push-pull driver in communications with the second conductor,

wherein the first push-pull driver is adapted to source current to the anode contacts and the second push-pull driver is adapted to sink current from the cathode contacts so as to activate one of the LEDs, and

wherein the first push-pull driver is adapted to sink current and the second push-pull driver is adapted to source current so as to back bias deactivated LEDs.

15. A physiological sensor method comprising:

sequentially addressing a plurality of light emitting sources using a plurality of conductors of an electrical grid so as to emit light having a plurality of wavelengths that when attenuated by body tissue is indicative of at least one physiological characteristic; and

detecting the emitted light after attenuation by body tissue.

16. The method according to claim 15 further comprising connecting one of each of the light emitting sources at a unique junction of the electrical grid.

17. The method according to claim 16 further comprising:

addressing a row one of the conductors; and

addressing a column one of the conductors,

wherein the light emitting source connected between the addressed row and the addressed column is activated.

18. The method according to claim 17 further comprising push/pull driving activated ones of the light emitting sources.

19. The method according to claim 18 further comprising back biasing deactivated ones of the light emitting sources.

20. The method according to claim 19 further comprising:

providing a plurality of same wavelength ones of the light emitting sources; and

simultaneously addressing the same wavelength light emitting sources.

* * * * *